

# LOAN DOCUMENT

PHOTOGRAPH THIS SHEET

DTIC ACCESSION NUMBER

LEVEL

1  
INVENTORY

TP 1387

DOCUMENT IDENTIFICATION

JAN 1979

**DISTRIBUTION STATEMENT A**  
Approved for Public Release  
Distribution Unlimited

DISTRIBUTION STATEMENT

ACCESSION FOR	
NTIS	GRAM
DTIC	TRAC
UNANNOUNCED	
JUSTIFICATION	
BY	
DISTRIBUTION/	
AVAILABILITY CODES	
DISTRIBUTION	AVAILABILITY AND/OR SPECIAL
A-1	

DISTRIBUTION STAMP

DATE ACCESSIONED

DATE RETURNED

19990507 179

DATE RECEIVED IN DTIC

REGISTERED OR CERTIFIED NUMBER

PHOTOGRAPH THIS SHEET AND RETURN TO DTIC-FDAC

H  
A  
N  
D  
L  
E  
  
W  
I  
T  
H  
  
C  
A  
R  
E

RIA-79-U34

Technical Paper 1387

**TECHNICAL  
LIBRARY**

**Friction and Wear Characteristics  
of Iron-Chromium Alloys in Contact  
With Themselves and Silicon Carbide**

**Kazuhisa Miyoshi and Donald H. Buckley**

**JANUARY 1979**

**NASA**

NASA Technical Paper 1387

Friction and Wear Characteristics  
of Iron-Chromium Alloys in Contact  
With Themselves and Silicon Carbide

Kazuhisa Miyoshi  
*Kanazawa University*  
*Kanazawa, Japan*

and

Donald H. Buckley  
*Lewis Research Center*  
*Cleveland, Ohio*

**NASA**

National Aeronautics  
and Space Administration

**Scientific and Technical  
Information Office**

1979

## SUMMARY

An investigation was conducted to determine the effect of alloying elements on the friction and wear behavior of iron-chromium alloys with various concentrations of chromium alloyed in iron. Three sets of sliding friction experiments were conducted. In these experiments the alloys were in contact with (1) themselves, (2) single-crystal silicon carbide disk surfaces, and (3) a single-crystal abrasive grit of silicon carbide. The first two sets of experiments were conducted in a vacuum chamber at a pressure of  $10^{-8}$  pascal to maximize adhesive wear effects. The third set of experiments was conducted in mineral oil at atmospheric pressure to maximize abrasive wear effects. All experiments were conducted with loads of 0.05 to 0.4 newton at a sliding velocity of 3 millimeters per minute with a total sliding distance of 2.5 millimeters at room temperature.

The results of the investigation indicate that the coefficients of friction for the alloys sliding against themselves are between those for pure iron and pure chromium and are only slightly different with 1, 5, 9, 14, and 19 weight percent chromium in iron. The wear is due primarily to shearing, or tearing fracture, of the cohesive bonds in the bulk and plowing of the bulk by lumps of wear debris. There are only slight differences in coefficients of friction for iron-chromium alloys when sliding on silicon carbide. The coefficient of friction for the alloys are higher than those for pure iron and pure chromium. The alloy hardening observed in iron-chromium alloys plays a dominant role in controlling the abrasive friction and wear behavior of the alloys.

## INTRODUCTION

It is important to gain a better fundamental understanding of the industrial process of metal finishing. Because the process efficiency can be improved by a more judicious selection of materials, lubricants, and operating parameters, such knowledge can lead to reducing the energy consumed in the thousands of industrial finishing operations conducted daily.

The authors have already investigated the importance of both the adhesive and the abrasive contributions to material removal by silicon carbide from a pure metal and the wear of an abrasive such as silicon carbide when the metal is sliding against silicon carbide (refs. 1 to 3).

The chemical activity and shear modulus of the metal play important roles in friction and metal wear. The higher the chemical activity and the less the resistance to

shear the metal has, the higher is the coefficient of adhesive friction, the greater is the metal transfer to silicon carbide, and the rougher is the wear scar on the surface of the metal. Abrasive wear and friction are strongly related to the shear strength of the bulk metal (ref. 3). The coefficient of friction and the wear volume decrease linearly as the shear strength of the metal increases.

It is well known that the presence of small amounts of alloying elements in metals can markedly alter their surface activity. For example, the addition of small concentrations of aluminum to copper in the bulk results in a decrease in surface energy, increased resistance to deformation and adherence of the copper to gold (refs. 4 to 6). Alloy softening and hardening have also been observed in body-centered-cubic (bcc) iron as a result of additions such as nitrogen, nickel, and chromium (refs. 7 and 8). Thus, another matter of interest for the fundamental understanding of finishing is the effect alloying elements have on the tribological properties of the alloy, namely, the adhesive and abrasive contributions to material removal from the alloys.

This investigation was conducted to determine the effect of alloying elements on the friction and wear behavior of iron chromium alloys with various concentrations of chromium alloyed in iron. Three sets of sliding friction experiments were conducted with these alloys. The alloys were in contact with (1) themselves, (2) single-crystal silicon carbide flat surfaces, and (3) a single-crystal abrasive grit of silicon carbide. The first two sets of experiments were conducted in a vacuum chamber at a pressure of  $10^{-8}$  pascal to maximize adhesive wear. The third set of experiments was conducted in mineral oil at atmospheric pressure to maximize abrasive wear effects. The silicon carbide specimens simulating abrasive grits were 0.025-millimeter-radius, spherical silicon carbide riders. All experiments were conducted with loads of 0.05 to 0.4 newton (5 to 40 g) at a sliding velocity of 3 millimeters per minute with a total sliding distance of 2.5 millimeters at room temperature.

## MATERIALS

The alloys used in this investigation were prepared from 99.99 percent iron and 99.7 percent chromium. The alloys were all placed in zirconia molds and induction melted under an argon atmosphere. The as-cast structures (ingots) were then machined into disk and rider specimens. Alloys were prepared containing 1, 5, 9, 14, and 19 weight percent chromium in iron.

The single-crystal silicon carbide in these experiments was a 99.9-percent-pure compound of silicon and carbon having a hexagonal closed-packed crystal structure.

## APPARATUS

The apparatus used in this investigation are shown schematically in figure 1. The adhesive wear apparatus was mounted in a vacuum system and determined load and friction forces (fig. 1(a)). The vacuum system also contained the tool for surface analysis, an Auger emission spectrometer (AES). The operation of the apparatus is described in detail in reference 1. The abrasive wear apparatus (fig. 1(b)) was a system capable of applying load and measuring friction in oil at atmospheric pressure. A beam contains one flat machined normal to the direction of friction application. The end of the rod contains the silicon carbide rider. The load is applied by placing deadweights on a pan on top of the rod. Under an applied load the friction force is measured by strain gages.

## EXPERIMENTAL PROCEDURE

### Specimen Preparation

All rider specimens had hemispherical surfaces and were polished with 3-micrometer-diameter diamond powder and then 1-micrometer-diameter aluminum oxide powder. The radius of curvature of the alloy riders was 0.79 mm (1/32 in.); that of the silicon carbide spherical riders was 0.025 mm. The prismatic planes of the silicon carbide rider specimens were oriented such that they were parallel to the sliding interface (ref. 3).

The surfaces of the flat specimens were also polished with 3-micrometer diamond powder and then with 1-micrometer aluminum oxide powder. The basal planes of the silicon carbide flats were oriented such that they were parallel to the sliding interface.

### Procedure

The vacuum experiments were performed at a pressure of  $1.33 \times 10^{-8}$  pascal ( $10^{-10}$  torr). When this pressure was obtained, argon gas was bled back into the vacuum chamber to a pressure of 1.3 pascals, whereupon flats and rider surfaces were cleaned by a glow discharge with a 1000-volt-direct-current potential applied to them for 30 minutes. After sputter cleaning, Auger emission spectroscopy (AES) spectra of the disk surface were obtained to establish surface cleanliness. When there was an absence of foreign peaks in the AES spectra, friction experiments were conducted. Loads of 5 to 40 grams were applied to the rider-disk contact by deflecting the beam (fig. 1(a)). Both load and friction force were continuously monitored during a friction experiment. The sliding velocity was 3 millimeters per minute, with a total sliding distance of 2.5 millimeters.

All friction experiments in vacuum were conducted with the system evacuated to a pressure of  $10^{-8}$  pascal.

For the experiments with the single-crystal silicon carbide rider in oil, both the alloy and the silicon carbide surfaces were rinsed with 200-proof ethyl alcohol before use. The friction experiments were single pass. Experiments were conducted with a total sliding distance of 2.5 millimeters, at a sliding velocity of 3 millimeters per minute, at room temperature, at atmospheric pressure, and in mineral oil. Typical properties of the mineral oil are described elsewhere (ref. 3).

## RESULTS AND DISCUSSION

### Auger Analysis

Auger spectra of the as-received iron-chromium alloy surfaces were obtained before and after sputter cleaning. The spectra obtained before sputter cleaning for a 14-weight-percent chromium in iron alloy, as an example, revealed carbon, zirconium, and oxygen contamination peaks (fig. 2(a)). An example of an Auger spectrum after sputter cleaning for 60 minutes is shown in figure 2(b). Again, carbon and oxygen contamination peaks are evident. The carbon contamination, however, decreases as the chromium content in iron decreases; in fact, with 1-, 5-, and 9-weight-percent chromium in iron alloys, it was negligible. The carbon with 14- and 19-weight-percent-chromium in iron alloys may arise from the bulk contamination of the alloys. The Auger spectra after sputter cleaning by argon bombardment for 30 minutes and 90 minutes were almost the same as that in figure 2(b).

Figures 2(c) and (d) show the Auger spectra for pure iron and chromium surfaces after sputter cleaning. In these spectra iron or chromium peaks are clearly seen; however, a small carbon peak, which may have arisen from the bulk contamination of iron or chromium, is also present.

### Alloys Sliding on Themselves and Silicon Carbide in Vacuum

Alloys sliding on themselves. - Sliding friction experiments were conducted with iron-chromium alloys with various concentrations of chromium alloyed in iron in contact with themselves in vacuum. The data of figure 3 reveal that there were slight differences in the coefficients of friction with load. The friction traces of all the alloys were characterized by marked stick-slip behavior over the entire load range. This type of friction is expected where strong adhesion occurs at the interface. Note that an average

coefficient of friction in this investigation was calculated from maximum-peak-heights in the friction traces resulting from a single pass of a rider across the surface.

Experiments were also conducted with iron (99.99 percent pure) and chromium (99.7 percent pure) in contact with themselves. Coefficients of friction as a function of load are presented in figure 4. Examination of figure 4 indicates that the coefficients of friction for both iron and chromium are not constant but decrease as the load increases. The friction traces of both metals were characterized by marked stick-slip behavior over the entire load range. This type of friction is also expected where strong adhesion occurs at the interface as was observed with the alloys.

The average coefficients of friction for the various iron-chromium alloys in sliding contact with themselves at loads from 0.05 to 0.4 newton (5 to 40 g) are presented in figure 5. These are compared with those for iron and chromium in sliding contact with themselves. The data indicate there are only slight differences in the coefficients of friction with 1-, 5-, 9-, 14-, and 19-weight-percent-chromium iron alloys. The coefficients of friction for the alloys have values between those of pure iron and chromium. The coefficients of friction are approximately 2 with iron and 1 with chromium at a load of 0.2 newton (20 g).

The sliding of the iron-chromium alloy, chromium, and iron riders on themselves resulted in surface damage to both rider and disk specimens, and mutual transfer. Figures 6 and 7 are typical scanning electron micrographs obtained on the wear scar of the rider and the wear track on the disk of the 14-weight-percent-chromium in iron alloy. These figures reveal evidence for three types of wear processes in single-pass sliding: (1) shearing fracture of the cohesive bonds in the bulk, (2) formation of lumps by piling up of wear debris, and (3) formation of gross grooves by the plowing of the lumps of wear debris.

The shearing, or tearing fracture, of the cohesive bonds in the bulk material generally occurs at the beginning of the adhesive bond (junction) of alloys. Fracture pits are then produced in the wear scar or in the wear track (figs. 6 and 7). The formation of lumps and gross grooves generally occurs at the end of the adhesive bond, that is, after the fracture pitting.

More detailed observations of the wear scar and wear track were conducted to gain a better understanding for the lump and its behavior herein. Figures 8 to 10 show scanning electron micrographs of the rider wear scar of the 14-weight-percent-chromium in iron alloy sliding on itself. Figure 8 reveals that the cracks, which are observed at the lump, primarily propagate along one direction, as illustrated in this figure. This direction may be a specific direction of the crystal. Figure 9 is the area where one of the lumps was evident in figure 6. The cracks are generated and propagated around the lump. Moreover, cracks came out from an area on the under side of the lump, and the gross lumps generally have an amount of transferred alloy from the counter surface on

their back. Thus, the formation of lumps may be due to (1) piling up of wear debris, (2) transfer of alloy, and (3) imperfect fracture of cohesive bonds in the bulk.

Figure 10(a) reveals that lump wear debris, which was produced at the end of the wear scar in sliding, plowed the surface along the sliding direction, and produced a gross groove. Figure 10(a) shows the lump wear debris imbedded in the surface. Figure 10(b) shows the gross groove along the sliding direction after the lumps of wear debris had been ejected from the wear scar. Thus, the surfaces at the end of the wear scar or adhesive bonding in the wear track generally may contain the lump, the gross groove, or both.

Further, the nature of interaction of wear debris produced on the surfaces of the alloy sliding on itself was also examined. Figure 11(a) shows a straight groove along the sliding direction on the rider surface formed by plowing of the alloy wear debris. Figure 11(b) shows a row of indentations along the sliding direction formed by rolling of the alloy wear debris. This evidence indicates that the wear debris is work-hardened in the process of its formation.

Alloys sliding on silicon carbide. - Sliding friction experiments were conducted with iron-chromium alloy, pure iron, and pure chromium rider specimens in contact with single-crystal silicon carbide flat specimens in vacuum. Examination indicated no significant change in coefficients of friction with load. The friction traces were primarily characterized by stick-slip behavior. The average coefficients of friction over the entire load range for iron-chromium alloys, iron, and chromium are presented in figure 12 as functions of the weight percent of chromium in iron. The coefficients of friction for the alloys are higher than those for pure iron and pure chromium. The data of figure 12 also indicate no significant differences in the coefficients of friction with 5- to 19-weight-percent-chromium in iron alloys. This seems to arise from the little difference in the percent d bond character and the atomic radius between iron and chromium; that is, the chemical affinity of iron and chromium to silicon and carbon may make little difference in friction because (1) there was a good correlation between the coefficient of friction and the percent d bond character of transition metals, as was shown by the authors (ref. 1) and (2) the smaller atomic radius ratio slightly changes lattice parameter with chromium concentration. Note that the percent d bond character is 39.7 with iron and 39 with chromium (ref. 9). The atomic radius ratio of chromium-to-iron is 1.0063 (ref. 8).

Scanning electron micrographs of the wear scar on the various iron-chromium alloys after sliding against silicon carbide generally revealed a smooth surface with few grooves and indentations. This is similar to what was observed with the wear scar on iron in reference 2.

The wear scar on the 19-weight-percent-chromium in iron alloy, however, was locally much rougher, and had a large number of deep grooves and indentations.

Scanning electron micrographs of the wear track on the silicon carbide surface generated by single-pass sliding of the various iron-chromium alloys revealed very small particles and piled-up particles. There was very little evidence of a thin transfer film in the wear track. Thus, the transfer of alloys to silicon carbide is similar to that of iron reported in reference 1.

### Alloys Abraded with Silicon Carbide Rider in Oil

Sliding friction experiments were conducted with a 0.025-millimeter-radius, spherical silicon carbide rider in contact with disk surfaces of various iron-chromium alloys, pure iron, and pure chromium in mineral oil. The sliding involves a plastic flow and the generation of wear debris of alloy. Figure 13 shows typical surface profiles of a groove on iron-chromium alloys, iron, and chromium resulting from sliding of a silicon carbide rider at a load of 10 g. The surface profiles were recorded by a surface profilometer. Figure 13 reveals that the sliding action results in a permanent groove in the surface with considerable deformed metal piled up along the sides of the groove. The volume of the groove plowed out strongly depends on the weight percent of chromium in iron. Therefore, a contact pressure was estimated from the width of surface profile shown in figure 13. The width  $D$  of the groove is defined as indicated in figure 14. The contact pressure  $P$  while sliding may, then, be defined by  $P = W/A$  where  $W$  is the applied normal load and  $A$  is the projected area of contact and is given by  $A = \pi D^2/8$  (only the front half of the rider is in contact with the disk specimen). The contact pressure generated with the 0.025-millimeter-radius silicon carbide rider is presented in figure 14 as a function of the chromium content in weight percent. Experiments were conducted at loads of 0.05 newton (5 g) in reference 8 and 0.1 newton (10 g) in this study. The chromium additions of up to 14 weight percent resulted in a continuous increase in the contact pressure from that observed with iron.

Alloy softening and hardening in body-centered-cubic metals is a well-known phenomenon. The hardening and softening of iron-chromium alloys have been observed by Stephens and Witzke (ref. 8) and Allen and Jaffee (ref. 10). Stephens and Witzke have established a hardness minimum near 8 atomic percent chromium at 77 K, near 4 atomic percent at 188 K, and 1 atomic percent at 300 and 411 K. The data at 300 K are presented in figure 14. They suggest that the alloy hardening is due, primarily, to an intrinsic mechanism, namely, atomic size misfit, rather than to shear modulus differences. In figure 14 the contact pressure can be correlated with the Stephens' and Witzke's hardness data.

The coefficient of friction and the groove height  $H$  were examined as a function of the chromium content in iron herein. The data are presented in figure 15. The results in figure 15 indicate that the coefficient of friction and the groove height can be corre-

lated with chromium content. They decrease as the chromium content increases up to 14 weight percent chromium. But, at 19 weight percent, both are much higher than at 14 weight percent chromium. Thus, alloy hardening plays a dominant role in controlling the abrasive friction and wear behavior of binary iron-chromium alloys.

## SUMMARY OF RESULTS

The results obtained in this investigation are summarized as follows:

1. The coefficients of friction for the iron-chromium alloys sliding against themselves have values between those for pure iron and pure chromium and are only slightly different with 1-, 5-, 9-, 14-, and 19-weight-percent chromium in iron. The wear is due primarily to shearing, or tearing fracture, of the cohesive bonds in the bulk and plowing of the bulk by lumps of wear debris.
2. There are only slight differences in coefficients of friction for the various iron-chromium alloys when sliding on silicon carbide.
3. The coefficients of friction for the alloys are higher than those for pure iron and pure chromium.
4. The alloy hardening observed in iron-chromium alloys plays a dominant role in controlling the abrasive friction and wear behavior of the alloys.
5. The coefficient of friction and the volume of the groove plowed with a silicon carbide rider can be correlated directly with the chromium content in iron.

Lewis Research Center,  
National Aeronautics and Space Administration,  
Cleveland, Ohio, September 20, 1978,  
506-16.

## REFERENCES

1. Miyoshi, Kazuhisa; and Buckley, Donald H.: Friction and Metal Transfer for Single-Crystal Silicon Carbide in Contact with Various Metals in Vacuum. NASA TP-1191, 1978.
2. Miyoshi, Kazuhisa; and Buckley, Donald H.: Wear of Single-Crystal Silicon Carbide in Contact with Various Metals in Vacuum. NASA TP-1198, 1978.
3. Miyoshi, Kazuhisa; and Buckley, Donald H.: Friction and Wear of Metals with a Single-Crystal Abrasive Grit of Silicon Carbide-Effect of Shear Strength of Metal. NASA TP-1293, 1978.

4. Jordan, L. K.; and Scheibner, E. J.: Characteristic Energy Loss Spectra of Copper Crystals with Surfaces Described by LEED. *Surface Sci.*, vol. 10, 1968, pp. 373-391.
5. Evans, K. R.; and Flanagan, W. F.: Solid-Solution Strengthening of Face Centered Cubic Alloys. *Phil. Mag.*, vol. 18, no. 155, Nov. 1968, pp. 977-983.
6. Buckley, Donald H.: A LEED Study of the Adhesion of Gold to Copper and Copper-Aluminum Alloys. NASA TN D-5351, 1969.
7. Christ, B. W.; Gamble, R. P.; and Smith, G. V.: On the Distinction Between Alloy Softening due to Nitrogen and Nickel in Dilute Lattice Solution in Iron. *Scripta Met.*, vol. 3, no. 8, Aug. 1969, pp. 521-530.
8. Stephens, Joseph R.; and Witzke, Walter R.: Alloy Softening in Binary Iron Solid Solutions. *J. Less-Common Metals*, vol. 48, Aug. 1976, pp. 285-308.
9. Pauling, L.: A Resonating-Valence-Bond Theory of Metals and Intermetallic Compounds. *Proc. Roy. Soc., Ser. A*, vol. 196, no. 1046, Apr. 7, 1949, pp. 343-362.
10. Allen, B. C.; and Jaffee, R. I.: The Hardness Behavior of Chromium Alloyed with Group IV-A to VIII Transition Metals. *Trans. Am. Soc. Metals*, vol. 56, no. 3, Sept. 1963, pp. 387-402.

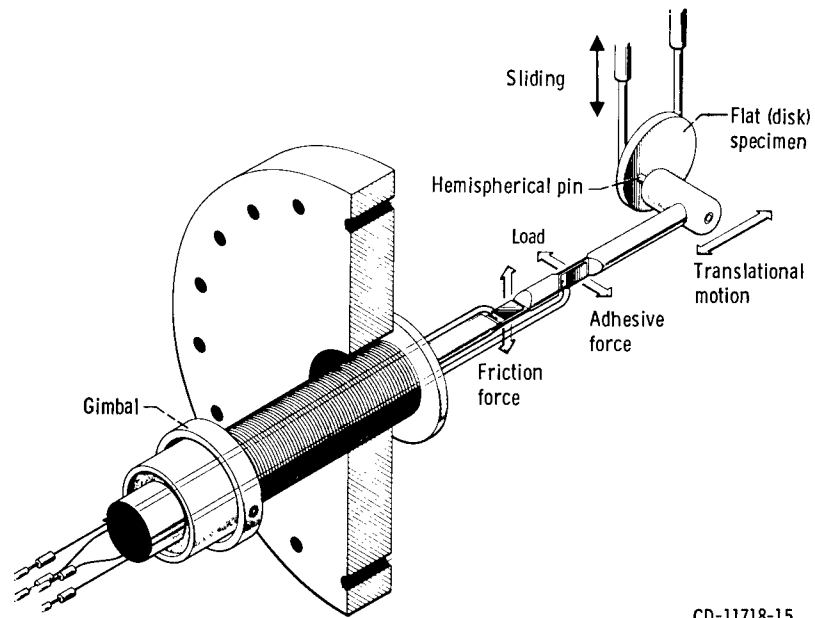

CD-11718-15

(a) Adhesive-wear apparatus.

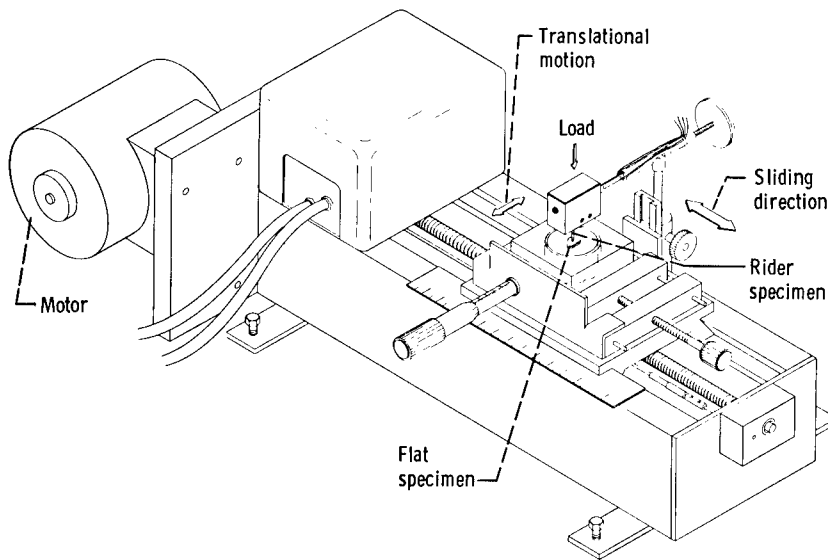

CD-12079-26

(b) Abrasive wear apparatus.  
Figure 1. - Friction and wear apparatus.

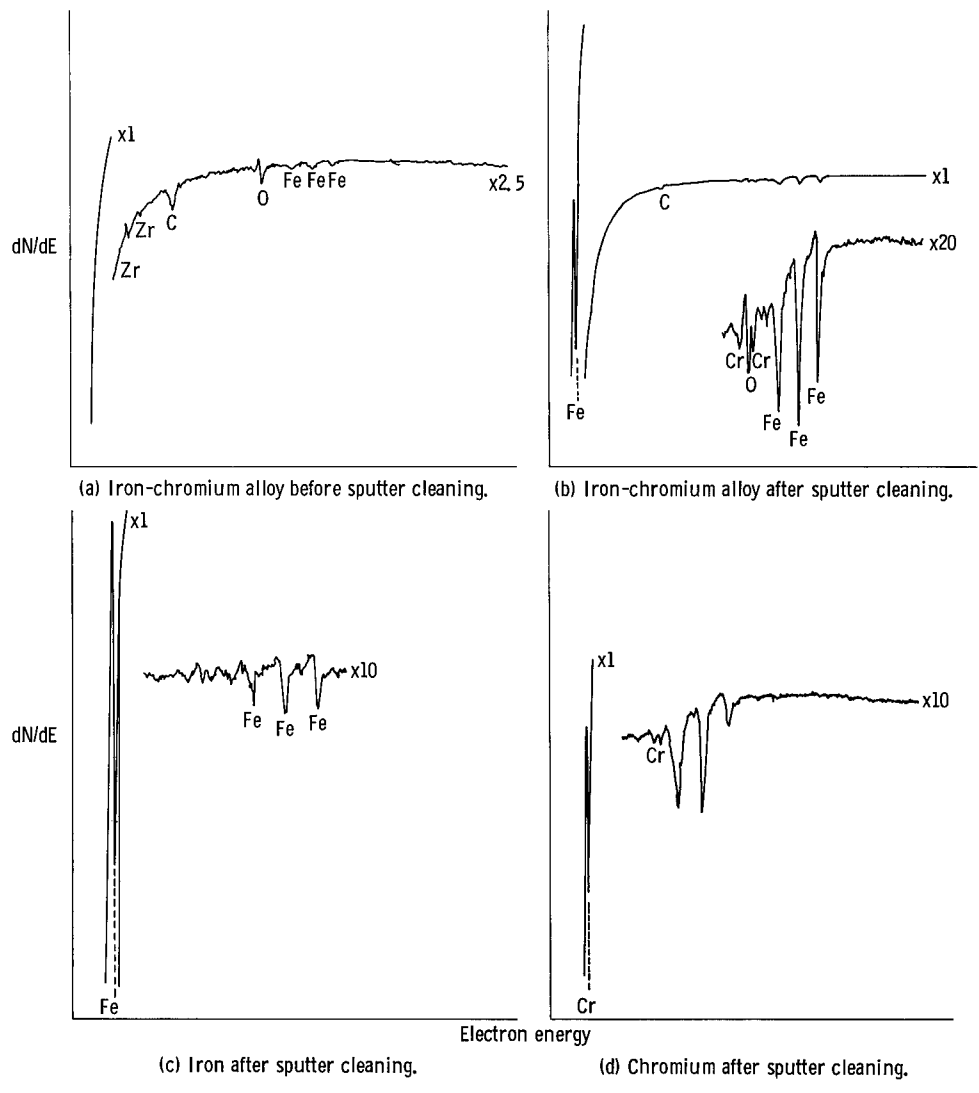

Figure 2. - Auger emission spectra for 14 weight percent iron-chromium alloy, iron, and chromium surfaces.

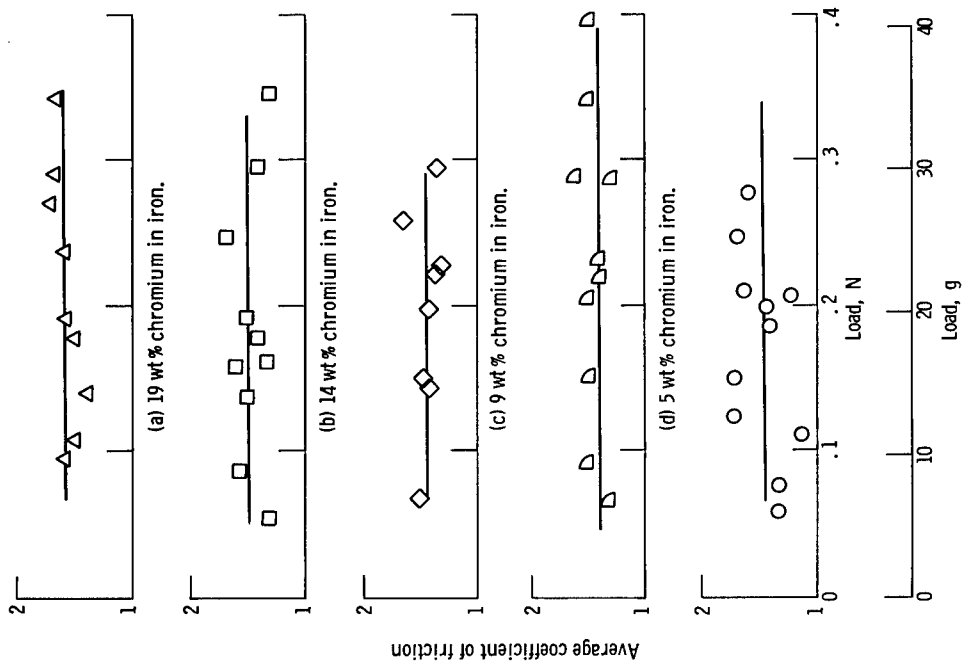

Figure 3. - Average coefficients of friction calculated from maximum peak heights in friction trace as function of load for various iron-chromium alloys sliding on themselves. Single pass; sliding velocity, 3 mm/min; room temperature; vacuum pressure,  $10^{-8}$  pascal.

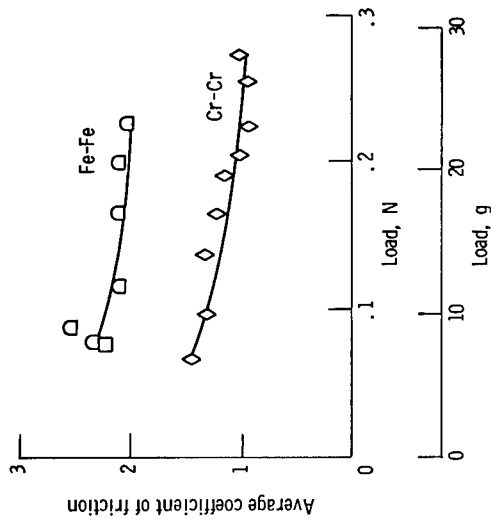

Figure 4. - Average coefficients of friction calculated from maximum peak heights in friction trace as function of load for iron and chromium sliding on themselves. Single pass; sliding velocity, 3 mm/min; room temperature; vacuum pressure,  $10^{-8}$  pascal.



Figure 5. - Average coefficients of friction for iron-chromium alloys, iron, and chromium sliding on themselves. Single pass; sliding velocity, 3 mm/min; load, 0.05 to 0.4 N (5 to 40 g) for alloys, and 0.2 N (20 g) for iron and chromium; room temperature; vacuum pressure,  $10^{-8}$  pascal. (Data from figs. 3 and 4.)

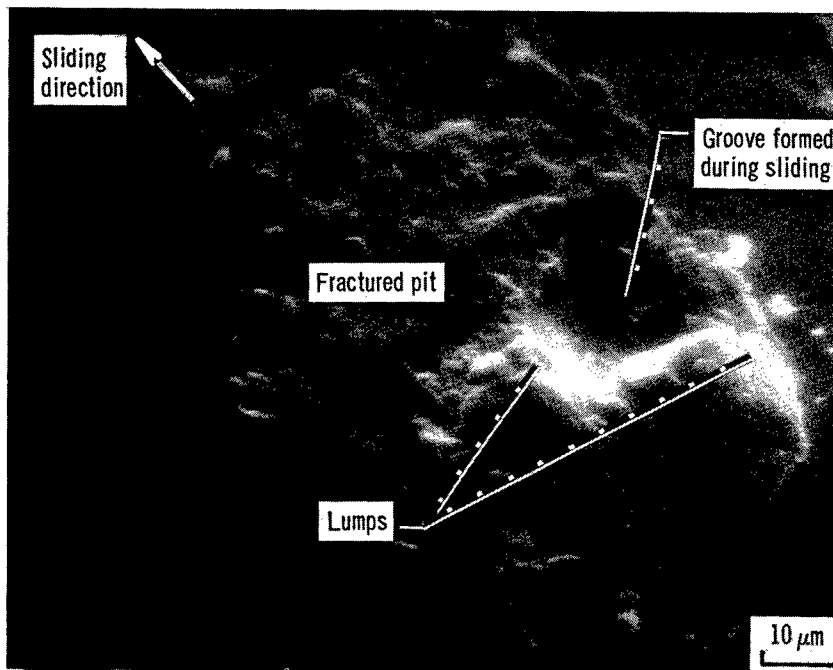

Figure 6. - Wear scar on iron-chromium alloy (14 wt. % Cr) rider produced during sliding contact with itself. (Scanning electron micrograph)

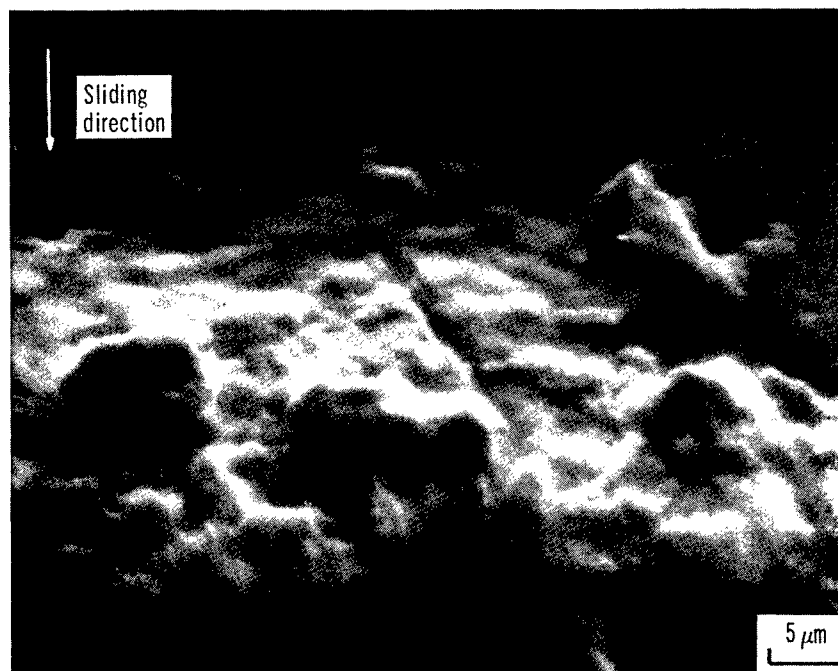
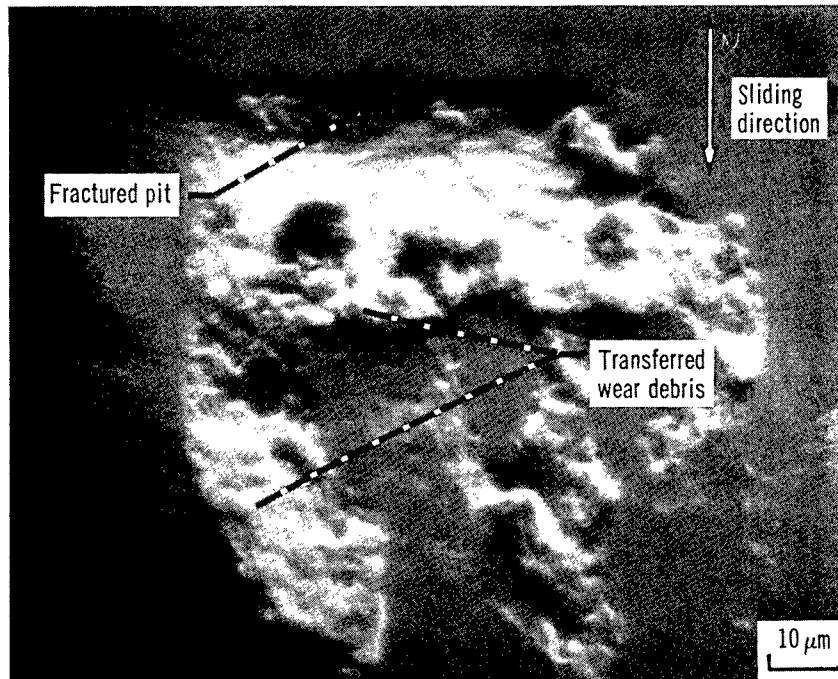
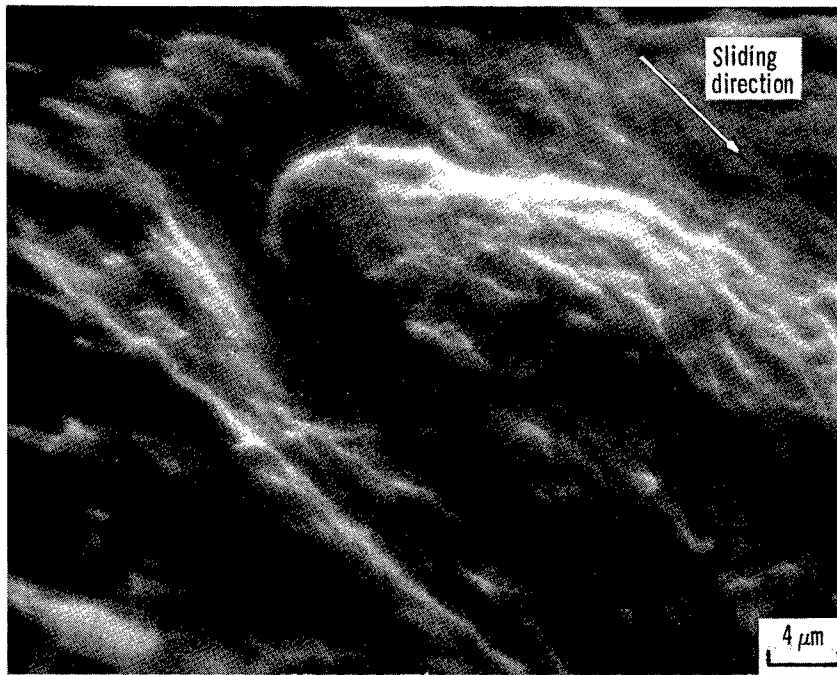

Figure 7. - Wear track on iron-chromium alloy (14 wt. % Cr) disk produced during sliding contact with itself. (Scanning electron micrographs)



Scanning electron micrograph

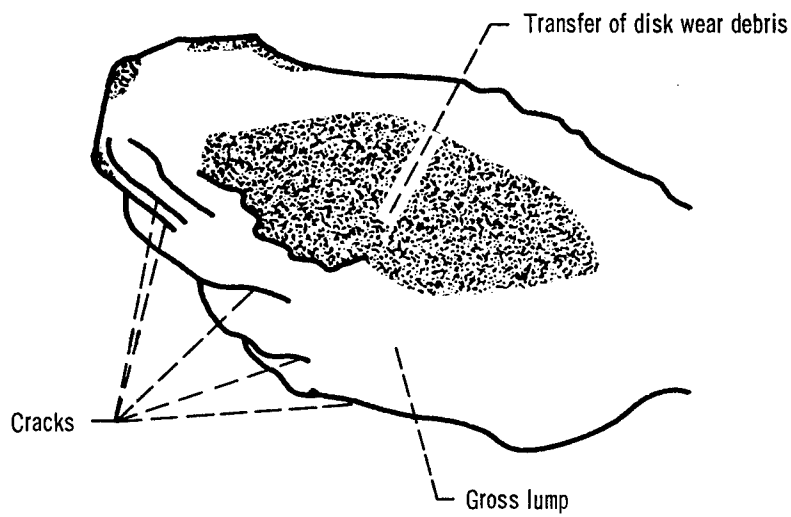

Figure 8. - Wear scar on iron-chromium alloy (14 wt. % Cr) rider showing lump and cracks.

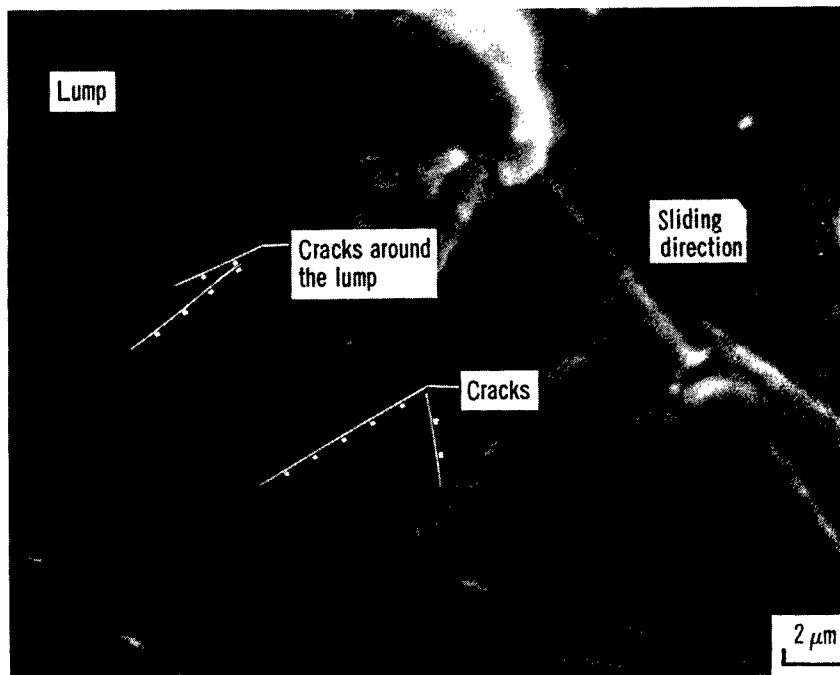
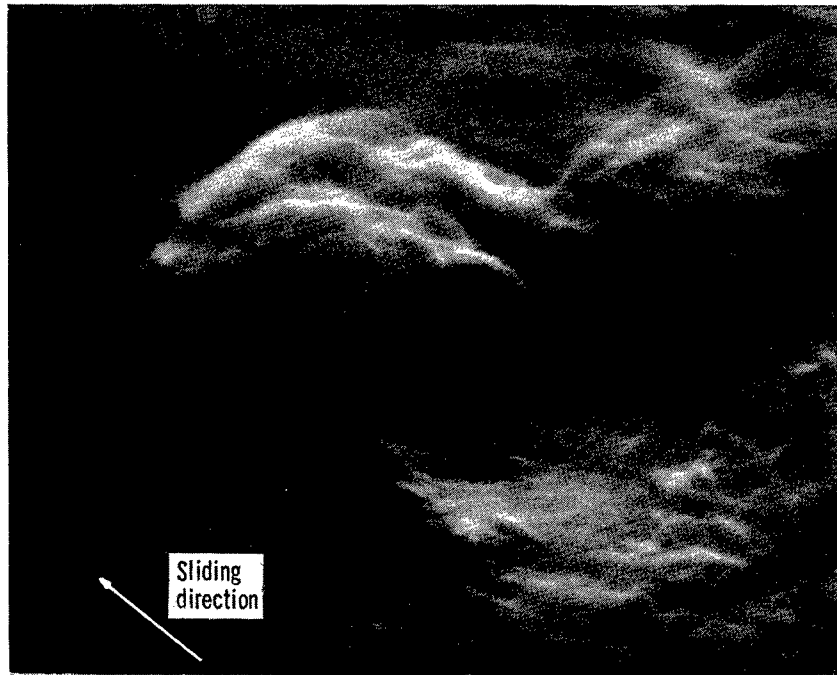
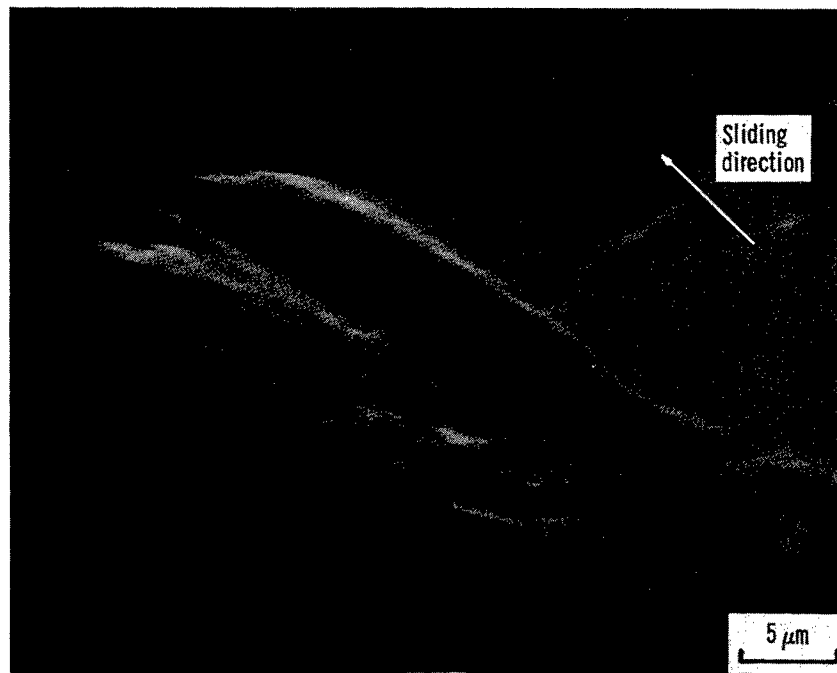

Figure 9. - End of wear scar on Fe-Cr alloy (14 wt. % Cr) rider showing lump and cracks around the lump. (Scanning electron micrograph)



(a) Lump and groove.



(b) Groove.

Figure 10. - Grooves on iron-chromium alloy (14 wt. % Cr) rider produced by lump wear debris during sliding contact with itself. (Scanning electron micrographs)

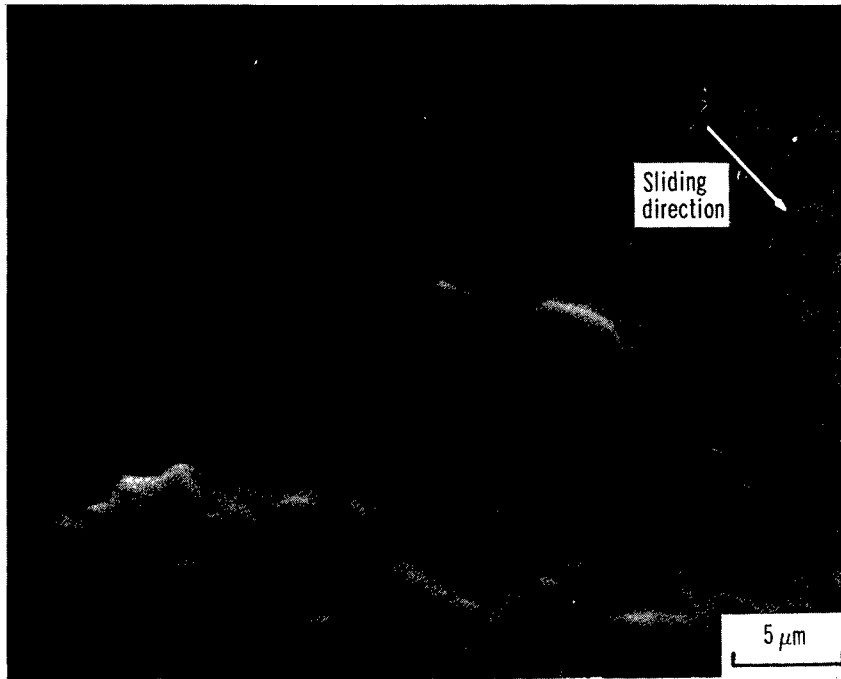

(a) Groove on rider.

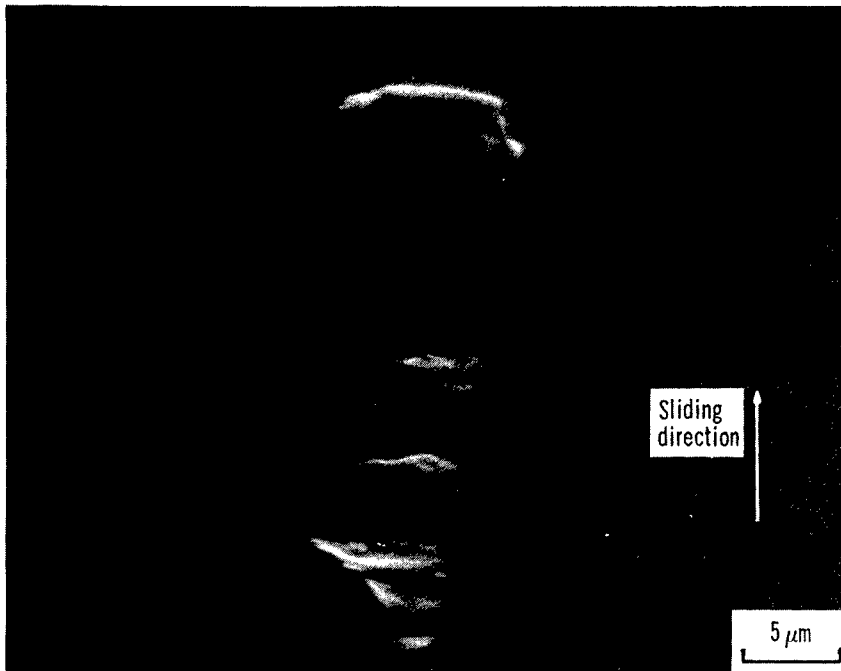

(b) Indentations on disk .

Figure 11.- Groove and indentations produced by wear debris during sliding of Fe-Cr alloy contact (14 wt. % Cr) with itself.

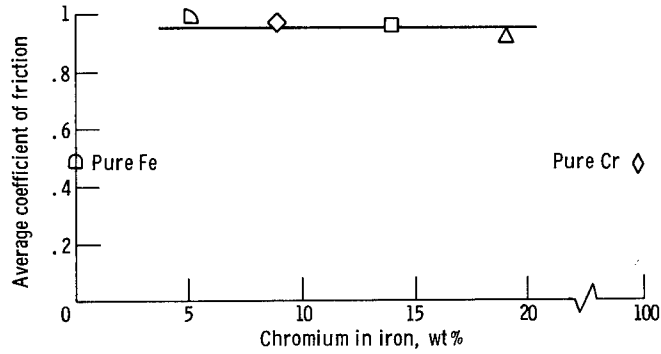

Figure 12. - Average coefficients of friction for iron-chromium alloys, iron, and chromium sliding on single-crystal silicon carbide (0001) surface in the  $10\bar{1}0$  direction. Single pass; sliding velocity, 3 mm/min; load, 0.05 to 0.3 N (5 to 30 g); room temperature; vacuum pressure,  $10^{-8}$  pascal.

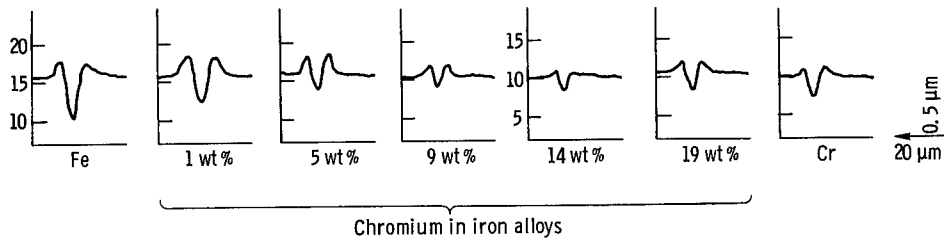

Figure 13. - Grooves on iron-chromium alloys, iron, and chromium. Single-pass sliding of 0.025-mm-radius silicon carbide rider in mineral oil. Sliding velocity, 3 mm/min; load, 0.1 N (10 g); room temperature.

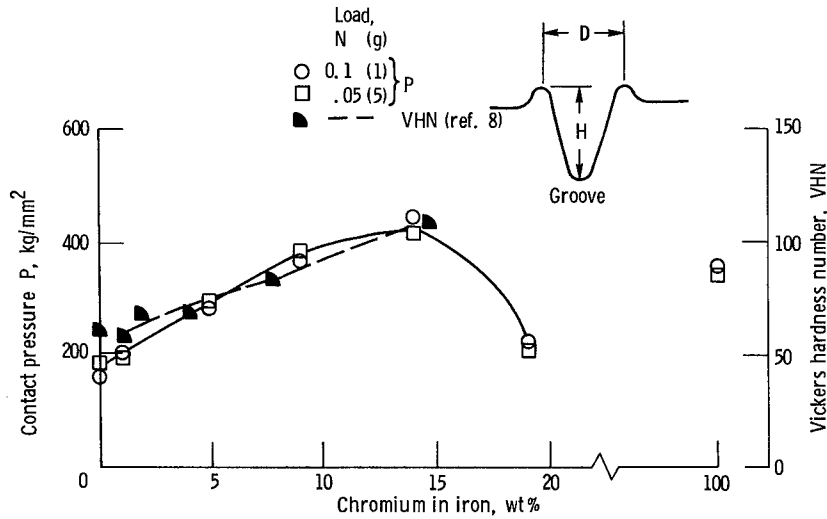

Figure 14. - Contact pressure and Vickers hardness (ref. 8) for iron-chromium alloys, iron, and chromium as result of single-pass sliding of 0.025-millimeter-radius silicon carbide rider in mineral oil. Sliding velocity, 3 mm/min; room temperature.

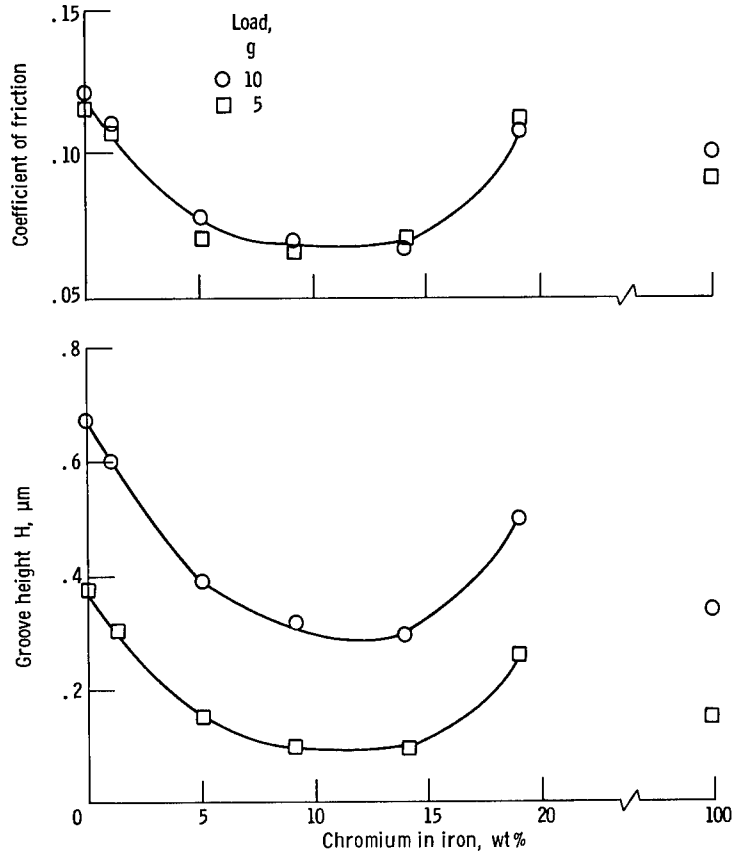

Figure 15. - Coefficient of friction and groove height for Fe-Cr alloys, iron, and chromium as result of single-pass sliding of 0.025-millimeter-radius silicon carbide rider in mineral oil. Sliding velocity, 3 mm/min; room temperature.

1. Report No. NASA TP-1387	2. Government Accession No.	3. Recipient's Catalog No.	
4. Title and Subtitle <b>FRICION AND WEAR CHARACTERISTICS OF IRON-CHROMIUM ALLOYS IN CONTACT WITH THEMSELVES AND SILICON CARBIDE</b>		5. Report Date January 1979	6. Performing Organization Code
		8. Performing Organization Report No. <b>E-9670</b>	10. Work Unit No.
7. Author(s) <b>Kazuhisa Miyoshi and Donald H. Buckley</b>		11. Contract or Grant No.	
9. Performing Organization Name and Address <b>National Aeronautics and Space Administration Lewis Research Center Cleveland, Ohio 44135</b>		13. Type of Report and Period Covered <b>Technical Paper</b>	
		14. Sponsoring Agency Code	
12. Sponsoring Agency Name and Address <b>National Aeronautics and Space Administration Washington, D. C. 20546</b>		15. Supplementary Notes <b>Kazuhisa Miyoshi, Kanazawa University, Kanazawa, Japan, and National Research Council - NASA Research Associate; Donald H. Buckley, Lewis Research Center.</b>	
16. Abstract Sliding friction experiments were conducted with various iron-chromium alloys in contact with (1) themselves, (2) single-crystal silicon carbide disks, and (3) a single-crystal abrasive grit of silicon carbide. Results indicate the coefficients of friction for the alloys sliding against themselves are between those for pure iron and pure chromium, and are only slightly different with 1, 5, 9, 14, and 19 weight percent chromium in iron. The wear is due, primarily, to shearing, or tearing fracture, of the cohesive bonds in the bulk metal and plowing of the bulk by lumps of wear debris. There are only slight differences in the coefficients of friction for the various alloys when sliding on silicon carbide. The coefficient of friction for the alloys are higher than those for pure iron and pure chromium. Alloy hardening observed in the alloys plays a dominant role in controlling the abrasive friction and wear behavior of the alloys.			
17. Key Words (Suggested by Author(s))		18. Distribution Statement <b>Unclassified - unlimited STAR Category 37</b>	
19. Security Classif. (of this report) <b>Unclassified</b>	20. Security Classif. (of this page) <b>Unclassified</b>	21. No. of Pages <b>21</b>	22. Price* <b>A02</b>