

NAVAL POSTGRADUATE SCHOOL MONTEREY, CALIFORNIA



THESIS

VISUAL ANALYSIS OF A RADIO FREQUENCY
TRACKING SYSTEM FOR VIRTUAL
ENVIRONMENTS

by

Philip E. Campbell

June 1999

Thesis Advisor:
Co-Advisor:

Rudy Darken
Xavier Maruyama

19990517 008

Approved for public release; distribution unlimited.

REPORT DOCUMENTATION PAGE

Form Approved OMB No. 0704-0188

Public reporting burden for this collection of information is estimated to average 1 hour per response, including the time for reviewing instruction, searching existing data sources, gathering and maintaining the data needed, and completing and reviewing the collection of information. Send comments regarding this burden estimate or any other aspect of this collection of information, including suggestions for reducing this burden, to Washington Headquarters Services, Directorate for Information Operations and Reports, 1215 Jefferson Davis Highway, Suite 1204, Arlington, VA 22202-4302, and to the Office of Management and Budget, Paperwork Reduction Project (0704-0188) Washington DC 20503.

1. AGENCY USE ONLY (<i>Leave blank</i>)	2. REPORT DATE June 1999	3. REPORT TYPE AND DATES COVERED Master's Thesis	
4. TITLE AND SUBTITLE VISUAL ANALYSIS OF A RADIO FREQUENCY TRACKING SYSTEM FOR VIRTUAL ENVIRONMENTS		5. FUNDING NUMBERS	
6. AUTHOR(S) Campbell, Philip E.			
7. PERFORMING ORGANIZATION NAME(S) AND ADDRESS(ES) Naval Postgraduate School Monterey CA 93943-5000		8. PERFORMING ORGANIZATION REPORT NUMBER	
9. SPONSORING/MONITORING AGENCY NAME(S) AND ADDRESS(ES)		10. SPONSORING/MONITORING AGENCY REPORT NUMBER	
11. SUPPLEMENTARY NOTES The views expressed in this thesis are those of the author and do not reflect the official policy or position of the Department of Defense or the U.S. Government.			
12a. DISTRIBUTION/AVAILABILITY STATEMENT Approved for public release; distribution is unlimited.		12b. DISTRIBUTION CODE	
<p>13. ABSTRACT (<i>maximum 200 words</i>)</p> <p>A variety of position tracking technologies have been utilized for virtual environments. Each has a different set of strengths and weaknesses which are usually compared on paper with numbers or generic statements. This thesis develops a methodology for the creation of 3D visualization tools to analyze position tracking technologies and their effectiveness under specific conditions. The methodology includes developing the questions, the models, the simulations, the visualization, and the rendering.</p> <p>This thesis applies the methodology to Advanced Position Systems, Inc.'s RF tracking system which can be easily configured for large volume spaces, unlike any of the other technologies. The analysis asks "How does the positioning of the receivers affect the relative accuracy throughout the target volume?". The model uses the solution to the Time Difference of Arrival (TDOA) equations used by the system and the simulation evaluates the position error throughout the volume with a constant error in the TDOA measurements. Point icons represent the data and the Virtual Reality Modeling Language renders the visualization. The asymmetric error profile revealed by this 3D visual analysis arises from the asymmetric arrangement of the TDOA measurements and is not readily apparent with other analytical techniques.</p>			
14. SUBJECT TERMS Simulation, Visualization, Tracking		15. NUMBER OF PAGES 96	
		16. PRICE CODE	
17. SECURITY CLASSIFICATION OF REPORT Unclassified	18. SECURITY CLASSIFICATION OF THIS PAGE Unclassified	19. SECURITY CLASSIFICATION OF ABSTRACT Unclassified	20. LIMITATION OF ABSTRACT UL

NSN 7540-01-280-5500

Standard Form 298 (Rev. 2-89)
Prescribed by ANSI Std. Z39-18 298-102

Approved for public release; distribution is unlimited.

**VISUAL ANALYSIS OF A RADIO FREQUENCY TRACKING SYSTEM FOR
VIRTUAL ENVIRONMENTS**

Philip E. Campbell
Lieutenant, United States Navy
B.S., United States Naval Academy, 1988

Submitted in partial fulfillment
of the requirements for the degree of

**MASTER OF SCIENCE IN COMPUTER SCIENCE
MASTER OF SCIENCE IN APPLIED PHYSICS**

from the

**NAVAL POSTGRADUATE SCHOOL
June 1999**

Author:

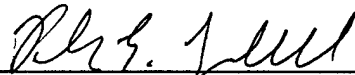

Philip E. Campbell

Approved by:



Rudy Darken, Thesis Advisor

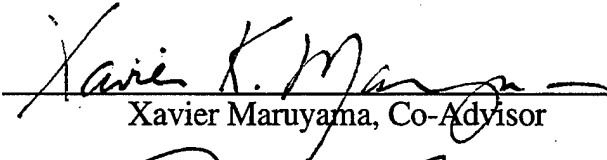

Xavier Maruyama, Co-Advisor

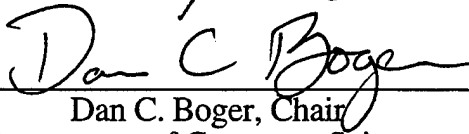

Dan C. Boger, Chair
Department of Computer Science



William B. Maier, Chair
Department of Physics

ABSTRACT

A variety of position tracking technologies have been utilized for virtual environments. Each has a different set of strengths and weaknesses which are usually compared on paper with numbers or generic statements. This thesis develops a methodology for the creation of 3D visualization tools to analyze position tracking technologies and their effectiveness under specific conditions. The methodology includes developing the questions, the models, the simulations, the visualization, and the rendering.

This thesis applies the methodology to Advanced Position Systems, Inc.'s RF tracking system which can be easily configured for large volume spaces, unlike any of the other technologies. The analysis asks "How does the positioning of the receivers affect the relative accuracy throughout the target volume?". The model uses the solution to the Time Difference of Arrival (TDOA) equations used by the system and the simulation evaluates the position error throughout the volume with a constant error in the TDOA measurements. Point icons represent the data and the Virtual Reality Modeling Language renders the visualization. The asymmetric error profile revealed by this 3D visual analysis arises from the asymmetric arrangement of the TDOA measurements and is not readily apparent with other analytical techniques.

TABLE OF CONTENTS

I. INTRODUCTION	1
A. OVERVIEW	1
B. PURPOSE	1
C. ORGANIZATION	2
II. BACKGROUND	5
A. TRACKER TECHNOLOGIES FOR VIRTUAL ENVIRONMENTS	5
1. What is VE Tracking	5
2. Survey of Current Tracking Technologies	5
a. Mechanical Trackers	6
b. Optical Trackers	6
c. Magnetic Trackers	8
d. Acoustic Trackers	8
3. Framework for Assessing Tracking Technologies	9
a. Resolution and Accuracy	9
b. Responsiveness: Sample Rate, Data Rate, Update Rate, and Lag	10
c. Robustness	10
d. Registration	10
e. Sociability	11
f. Qualitative Analysis	11
B. ADVANCED POSITION SYSTEMS RF TRACKING SYSTEM	13
1. Goals of system	13
2. System Principle	13
3. Phase I Implementation	16
4. Results	16
5. Proposed Phase II Implementations	17
III. TRACKER ANALYSIS METHODOLOGY	19
A. DEVELOPING THE QUESTION TO ASK	20
B. WHAT DATA ANSWERS THE QUESTION	23
1. Determine the Model of the System	24
2. Determine the Method of Simulation	28
C. DECIDING HOW TO REPRESENT THE DATA	28
1. Developing the Visualization	30
2. Challenges of Visualization	32
a. Information Visualization	32
b. Meeting the Demands of Interactive and Collaborative Visualization	33
c. Metrics, Standards, and Benchmarks	33
d. The Complexity of Data Sets	33
e. Multiresolution Models	34
f. Segmentation and Feature Extraction	34
g. Integration and Registration	34
h. Volume Modeling	34
i. The World Wide Web	35

3. Rendering the Visualization	35
D. OTHER CONSIDERATIONS	38
1. The Audience	38
2. The Tools Available	39
IV. ERROR ANALYSIS OF THE RF TRACKING SYSTEM	41
A. OTHER CONSIDERATIONS	41
1. The Audience	41
2. The Tools Available	41
B. DEVELOPING THE QUESTION TO ASK	42
C. WHAT DATA ANSWERS THE QUESTION	44
1. Determine the Model of the System	44
2. Determine the Method of Simulation	46
D. DECIDING HOW TO REPRESENT THE DATA	47
1. Developing the Visualization	47
2. Examples of 3D Visualization Techniques	48
a. Interactive Volume Navigation	48
b. Virtual Data Visualizer	50
c. Interval Volume	52
d. High Accuracy Volume Renderer (HIAC)	53
e. Multiresolution Volume data	54
f. Tracking 3D Features	56
g. Gaseous Rendering	57
h. Iconic visualization	59
i. Texturing Transparent Shapes	61
j. Visualizing Position Error Data	61
3. Rendering the visualization	64
V. IMPLEMENTATION	65
A. PROGRAMMING THE MODEL AND SIMULATION	65
B. PROGRAMMING THE VISUALIZATION	66
VI. RESULTS OF ANALYSIS	69
VII. CONCLUSIONS AND RECOMMENDATIONS	73
APPENDIX. SOLUTION TO TDOA	75
LIST OF REFERENCES	83
INITIAL DISTRIBUTION LIST	85

ACKNOWLEDGMENT

The author would like to acknowledge Advanced Position Systems, INC. for the access to their design of a Radio Frequency tracking system. Thanks go to Professor Darken who stayed the course during the long thesis preparation and to Professor Maruyama for stepping in as a bottom of the ninth substitute. Most importantly, thanks and love go to Jann for her support during the extra year in the penalty box.

I. INTRODUCTION

A. OVERVIEW

This thesis began with the idea of simulating an emerging radio frequency (RF) tracking technology which is being developed under a Defense Small Business Innovation Research (SBIR) Program contract by Advanced Position Systems, Inc. The RF tracking system is designed to track the position of an object in 3D space for the purpose of rendering a computer scene. The goal was to make the simulation available over the internet to anyone who would want to test the technology for use in Virtual Environments (VE). It became quickly apparent that the techniques used for this problem could be used for any tracking technology. What developed was a methodology for creating tools to analyze tracking systems and present the results over a network. The methodology presented in this thesis is applicable to modeling and simulation requirements beyond that specific to VE tracking technologies. For example, this methodology could be extended to physics applications such as those associated with molecular motion or satellite positioning and communication.

B. PURPOSE

There are a wide variety of tracking solutions available using many different technologies. Each has a different set of positive and negative characteristics. Unfortunately there is not an easy way to evaluate every technology with regard to the requirements of a specific task. The result is that a generic "best" solution has appeared. Many researchers simply use the same technology others use and adapt it to the situation since this appears simpler than researching every possible technology. This anecdotal evidence can be seen in a wide variety of virtual environment research.

The methodology discussed here is designed to provide a well defined approach to developing analysis tools for VE tracking systems. The five focus areas of the methodology are creating: (1) a practical question, (2) models to represent the question, (3) the simulations to turn the models into data which represents the answer, (4) a visual method to represent the data and communicate the answer, and (5) the rendering technique to display the visual representation of the answer. By using this method on the RF tracking system, an overreaching problem was turned into a manageable problem with immediate results.

The evaluation techniques developed here will only be used on an RF tracking system. The simulation provides an evaluation of how well this RF tracking system might perform. It takes an exact solution of the time differences that the receiver systems would measure and introduces a time error to get a measurement of error in the position the system would report. This is not a simulation of the RF transmitter and receiver systems or the electrical systems that would provide the time difference seen by the system. Those forms of interference that might affect an RF system are not part of the evaluation. The system is also very dependent on the placement of the receiver systems. The simulation does allow for limitations on placement and its effects on the accuracy of the system tested.

C. ORGANIZATION

This Introduction describes a need for developing analysis tools for VE tracking systems. Chapter II provides a description and background of the majority of tracking systems in use plus a greater explanation of the RF tracking system designed by Advanced Tracking Systems, Inc. Chapter III develops the methodology for creating evaluation tools for VE tracking systems.

Chapter IV applies the methodology and designs a tool for analyzing the RF tracking system. Chapter IV also presents examples of 3D visualization techniques for applications related to but different from the particular system studied in this thesis. Chapter

V describes the implementation of the analysis tool. Chapter VI shows the results of the analysis and how it could benefit the development of the RF system. Chapter VII reveals how the methodology was effective in developing the analysis tool for the RF system and the future work for which it can be used.

II. BACKGROUND

A. TRACKER TECHNOLOGIES FOR VIRTUAL ENVIRONMENTS

1. What is VE Tracking

In the mid- 1960's, Sutherland used a position tracker to dynamically calculate the view required to produce a computer generated image in a virtual reality system(Meyer 1992). Sutherland's system consisted of a Head Mounted Display connected to a mechanical boom. Since the display was worn by a user, the position of the display relative to the user was fixed. With the boom in an initial position, a starting view was displayed. As the user moved, the boom measured the new positions and sent them to a computer which calculated the new views to be displayed. This process is representative of most VE tracking.

In augmented reality systems, where the user sees both generated views along with the real world, the initial position must coincide with real world coordinates. In the previous example, only a virtual coordinate system is required. VE tracking is not limited to tracking just the head of a user, however it represents the most challenging task for a tracking system and dominates most discussions of VE tracking requirements.

2. Survey of Current Tracking Technologies

Meyer, et al, provide a comprehensive discussion of VR tracking technologies. They set out to accomplish three goals: (1) a survey of current(circa 1992) position tracking technologies used for VR, (2) establish a framework to evaluate the suitability of an implementation for VR use, and (3) discuss the effect of position tracking on VR users with an emphasis on simulation sickness. This section will discuss the results of their survey

while the next section will discuss the framework developed for assessing these technologies.

There are four different technologies with various implementations used for the purpose of generating graphic views; mechanical, optical, magnetic, and acoustic. Two tracking technologies which are mentioned but were not used in 1992 for VE are inertial and eye tracking technologies. Inertial systems alone were not considered suitable and were not used for generating graphic views. Eye tracking systems track only the direction the eye points from the head by detecting movement of the fovea and not the position and orientation of the head.

a. Mechanical Trackers

Mechanical systems connect the remote object to a point of reference with jointed linkages. Goniometers are often used to measure the change in angle of the joints. The Sutherland system used a shaft which was connected to the reference point and the head-mounted display with universal joints. The shaft had a sliding section which allowed it to rotate and slide in and out. By measuring each linkage relative to the previous one, the position of the display can be found relative to the reference point. Two optional additions to mechanical systems add linkages which are manipulated by the hand and arm or allow for the linkage mechanism to act on the user which is called force feedback. Several systems, like NASA's Anthropomorphic Remote Manipulator, utilize this form of tracking for robotics control. MITI Robotics Research Lab developed a system that combined the boom type head mounted display with the exoskeletal linkages on the arm.

b. Optical Trackers

Optical systems represent the largest group of tracking systems, based on the number developed and not on how often they are actually used. The variety of

implementation techniques used can be divided into three categories, fixed transducer, pattern recognition, and laser ranging.

Fixed transducer systems utilize the known distance between a set of light emitters or sensors. If the sensors are located on mobile remote objects then the system is called inside-out since the sensors look out to the fixed emitters. Conversely, the system is called outside-in when the sensors are fixed and look into the emitters on the mobile object.

The Honeywell Rotating Beam is an inside-out system with two helmet mounted sensors and fixed position emitters each with two thin fan shape beams. The beams are swept across the working volume and detected by the sensors. The delay from a horizontal reference position to detection by the helmet sensors is proportional to the displacement angle. Using the fixed distance between the two sensors and the resultant angles, the position is found by triangulation.

Another inside-out system created by a University of North Carolina (UNC) research team uses four helmet mounted cameras with lateral-effect photodiodes and a ceiling of 2X2 ft tiles each with 32 individually addressable infrared LEDs. Each camera captures a picture of the diodes which are activated in a known sequence. These photocoordinates which are captured by the cameras can then be converted into the position of the sensors since the location of the LED's is known.

The SELSPOT tracker is an outside-in system developed by the Selective Electric Corporation of Sweden. A stereo pair of cameras track as many as 30 LEDs. The cameras' lateral-effect photodiodes measure the 2D location of the LEDs projected onto the surface of the diodes. The 3D data is calculated from each stereo pair of 2D data. At least three LEDs in a fixed position on a helmet must be tracked to calculate orientation.

Pattern Recognition systems are not entirely different from fixed transducers. The main difference is that only a single sensor is required. A vector to each emitter is calculated from the camera focal length, focal plane, and known image of the

source emitter. Typically used as an outside-in system, four emitters located at fixed positions on a helmet allow for orientation and positions to be calculated from the four vectors. The Honeywell LED Array uses active LEDs as emitters while the Honeywell Videometric uses non active unique symbology which must be illuminated as the source.

Laser Ranging should be listed with the other technologies that have not actually been used in a VR system. It is singled out as a strong possibility since it does not require a sensor or emitter on the mobile object. In other words it has a very desirable feature if a system could be made to work. The type of laser-ranging considered passed the laser light through a diffraction grating onto the volume of interest. A camera takes a picture of the pattern which is distorted by the objects. The distortions in the diffraction pattern are used to calculate distance.

c. Magnetic Trackers

Magnetic trackers represent the most widely used systems. All of the magnetic systems work on the same principles. Both the emitter, at a fixed location, and the sensor, on the mobile remote object, have three orthogonal coils. The emitter activates each of the coils separately in sequence. The sensor measures the field strength of each of its three coils during every activation of the emitter resulting in nine measurements. These nine measurements provide a relative change in position and orientation from the previous. The two most used systems are the Polhemus, which uses an AC emitter, and the Ascension Bird, which uses a DC emitter.

d. Acoustic Trackers

Acoustic systems have seen little development since an early start and are rarely used in VR research despite representing the only consumer level entries with the Mattel Power Glove and the Logitech 3D Mouse. Both of these systems measure the Time-

of-Flight (TOF) of a pulse from an emitter to a sensor. Several emitters are required to calculate the position of one sensor and multiple sensors are required to calculate orientation.

Another technique is used in Phase-Coherent (PC) trackers. Sutherland developed the mechanical tracker for the purpose of verifying the Seitz-Pezaris head-mounted display position tracker based on PC tracking. PC trackers measure distance by comparing the phase of the emitted signal to a reference signal. The remote mobile object must have an initial reference position to eliminate phase ambiguity. The Seitz-Pezaris system uses three separate emitters each with its own frequency on the remote object and four receivers in fixed locations. The position of each transmitter is calculated from the phase differences of each receiver pair and the orientation from the position of the three emitters.

3. Framework for Assessing Tracking Technologies

Position tracking for the control of computer-generated graphics can be evaluated according to the following five key measures: 1) resolution and accuracy, 2) responsiveness, 3) robustness, 4) registration and 5) sociability. This framework is qualitative instead of quantitative. Further research is required into human perception and how well each of these measures must be met to maintain the illusion of a VR system.

a. Resolution and Accuracy

Resolution is the smallest change that the system can detect. Movement smaller than the resolution will not be detected. Accuracy is how far the reported position may be from the actual position.

b. Responsiveness: Sample Rate, Data Rate, Update Rate, and Lag

The sample rate is how often the sensors are checked for data. The data rate is how often the position is computed. Sample rate can be much higher than data rate in order not to miss changes but the data rate (which can not be higher than the sample rate) is more important in evaluating the effectiveness of a system. The update rate is the rate that the data is reported to the system. The update rate is not limited by the display rate but the need to filter erroneous or erratic data can make it lower than the data rate. Lag or latency is the most significant of these measures because it is the delay between the time the position was measured and the time the position is reported. The maximum speed of the remote object times the lag represents an additional error in the reported system. While high update rates are required for a low lag, they do not guarantee it.

c. Robustness

Robustness is the ability of a system to accommodate the uncertainty and noise of the real world. The less the system is susceptible to outside interference, the more robust the system is.

d. Registration

Registration is the correspondence between actual and reported position and orientation. Registration differs from accuracy in two ways. Systems which measure the change in position instead of a direct measurement of position can have a cumulative error which results in poor registration. This is the primary reason inertial systems were not used alone. PC audio systems also suffer from an inability to directly measure position. Registration is dependent on whether a system is fully immersive VR (the viewer does not interact with the real world) or augmented reality (the viewer sees both real world and virtual world images). Clearly the augmented reality requires accurate registration between the real

world seen by the viewer and the virtual elements. In VR, the position may not have to register as well since it may be difficult for the viewer to notice the difference but orientation still requires accurate registration since the body still senses up from down.

e. Sociability

Sociability is the tracker's ability to track multiple targets or users. Clearly working volume affects sociability since a small working volume limits the number of individuals that can maneuver within the volume. Working volume itself is generally limited by the technology and the specific implementation. Sociability should primarily be applied to systems with large enough working volumes that could be used for multiple users. Systems that have a limited working volume are going to be used in situations where sociability should not be an issue.

f. Qualitative Analysis

Table 1 uses the above framework to provide a qualitative analysis of present VE tracking technologies. While the analysis provides some insight into how effective each technology may be for VE, it is too general to make an appropriate decision about which technology is best suited for a specific application.

	Mechanical	Optical	Magnetic	Acoustic
Accuracy and Resolution	Good	Good. Accuracy and resolution decrease as working volume increases. Multiple emitter-sensor systems have good working volume and accuracy	Good in small working volumes. Accuracy tends to diminish as emitter-sensor distance increases. Accuracy adversely affected by ferromagnetic objects in working volume	Good
Responsiveness	Good	Good. Optical systems can be well suited to real time applications	Relatively low data rates. Filtering required for distortions in emitted field can introduce lag	TOF: Good responsiveness at close range. Data rates diminish as range increases PC: High data rates unaffected by range
Robustness	Good. Not sensitive to errors introduced from the environment	Good. Some systems affected by ambient light	Ferromagnetic objects create eddy currents that distort the emitted field causing ranging errors	TOF: Low data rates cause vulnerability to ranging errors. Robustness diminishes as range increases and data rates drop PC: Excellent robustness
Registration	No reports	No reports	No reports	No reports
Sociability	Limited range Two systems cannot effectively occupy the same working volume	Sociability affected by tradeoff between range and accuracy. Multiple emitter-sensor systems improve sociability without affecting accuracy and resolution Inside-out systems are more fit than outside-in for tracking multiple remote objects Optical systems are vulnerable to occlusion	Most effective for small working volumes. Some implementations improve working volume by augmenting emitted field strength. However distortions from induced eddy currents increase with field strength Configurations available for allowing sensors to share emitters or for multiple emitters in same work space Magnetic systems are unaffected by non-ferromagnetic occlusion	TOF: Accuracy and responsiveness diminish as range increases. Small effective working volume can limit sociability PC: Large working volume offers good sociability. Increased range does not affect responsiveness Acoustic systems are vulnerable to occlusion
Comments	Cumbersome. Well suited to force feedback. Successful applications in Telerobotics	Compromise between range and accuracy inherent in wide-angle systems can be mitigated with use of multiple emitters, but at the cost of increased complexity Successfully used in cockpits	Available off-the-shelf. Relatively inexpensive. Most commonly used in current VR research Successfully used in cockpits	Acoustic systems are starting to appear in marketplace

Table 1 Qualitative analysis of present VE tracking technologies(Meyer 1992).

B. ADVANCED POSITION SYSTEMS RF TRACKING SYSTEM

This section will detail Advanced Position Systems's implementation of an RF tracking system for use in VE. The abstract from the Phase I Final Report (Advanced Position Systems, INC., 1996) explains the motivation for such a system.

The bottleneck of all current VE applications in both military and civilian is how to develop a 3D spatial tracking device with fast, accurate and cordless operation in a long range. All existing technologies including mechanical, magnetic, optical, ultrasonic and inertial tracking systems show various disadvantages, and can not satisfy such requirements. RF positioning systems are very fast and can be used in a long range by its nature. Unfortunately, all current RF positioning systems have too poor accuracy to be used in VE tracking systems.

A new RF 3D spatial positioning system for translational 3 DOF has been developed at Advanced Position Systems, Inc. The APSI technology greatly improves the RF positioning accuracy down to the mm scale for cordless tracking operations in a long range with no noise, low latency, high sampling rate, no line-sight restriction and low cost. It is a significantly breakthrough technology.

1. Goals of system

The stated goal for Phase I was to develop a 2D prototype of the RF tracking system. Because there was little difference between creating a 2D or a 3D version, the 3D version was created instead. Specific goals were range of 100m (radius), accuracy of 1mm, and latency less than .01ms. Other stated goals not included in the abstract were ease of set up, configurable for a variety of spaces, and remaining within cost constraints.

2. System Principle

The system is based on Time Difference of Arrival (TDOA). Figure 1 shows the major components. A portable transmitter, $P(x,y,z)$, sends out the RF pulse(s). The pulse travels to all four of the relay stations, $RS1(x_1,y_1,z_1)$, $RS2(x_2,y_2,z_2)$, $RS3(x_3,y_3,z_3)$ and

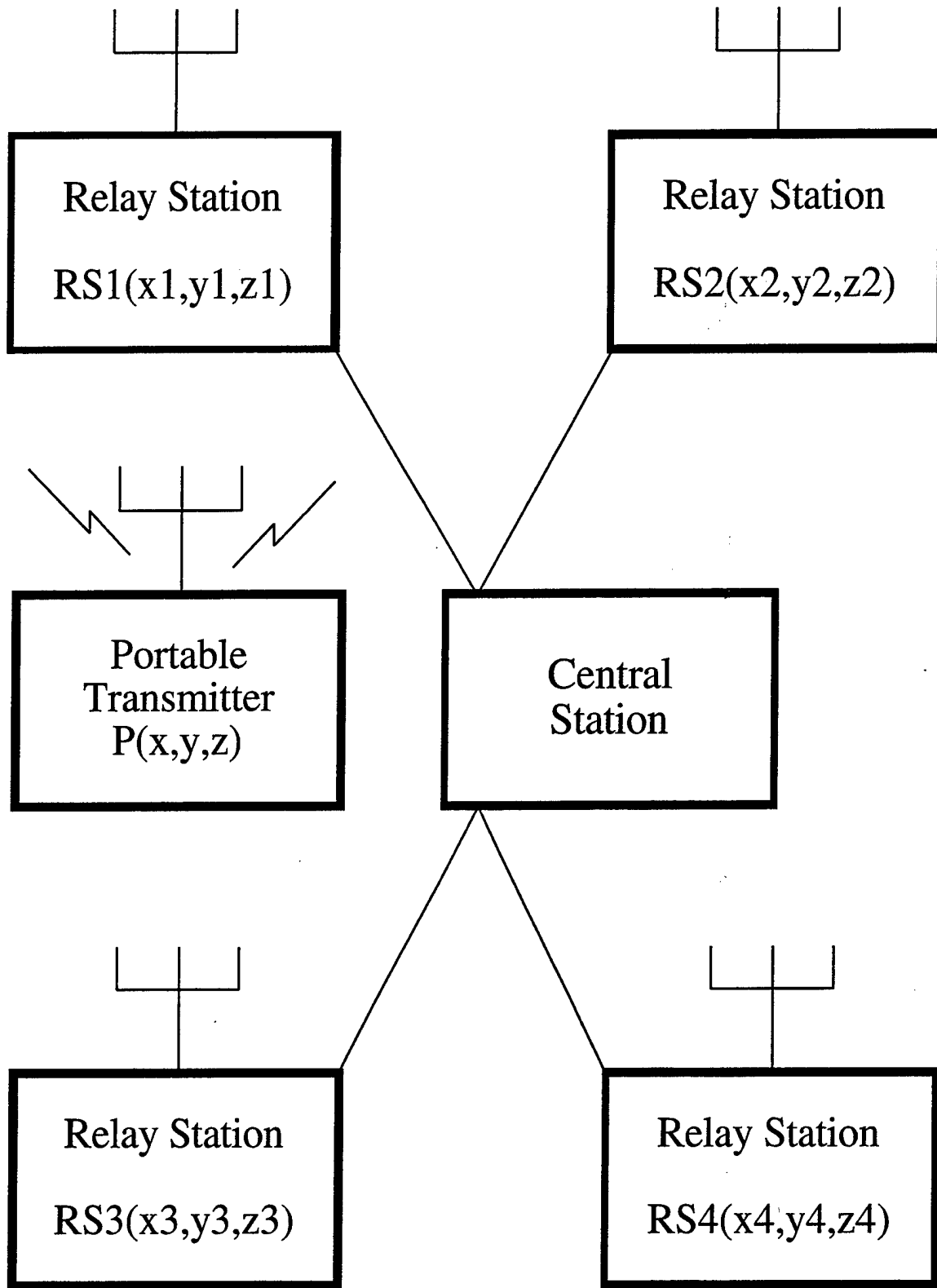

Figure 1 Block diagram of RF position tracker (Advanced Position Systems, Inc., 1996)

RS4 (x_4, y_4, z_4) , at the speed of light in air $(v = 3.0 \times 10^8 \text{ m/sec})$. The time it takes the signal to reach each of the four relay stations is represented in the four equations below.

$$t_1 = \frac{\sqrt{(x-x_1)^2 + (y-y_1)^2 + (z-z_1)^2}}{v} \quad (1)$$

$$t_2 = \frac{\sqrt{(x-x_2)^2 + (y-y_2)^2 + (z-z_2)^2}}{v} \quad (2)$$

$$t_3 = \frac{\sqrt{(x-x_3)^2 + (y-y_3)^2 + (z-z_3)^2}}{v} \quad (3)$$

$$t_4 = \frac{\sqrt{(x-x_4)^2 + (y-y_4)^2 + (z-z_4)^2}}{v} \quad (4)$$

The central station measures the TDOA by comparing the signals from the four relay stations. While several different combinations could be used, only three are required.

The three TDOA pairs used are represented in the three equations below.

$$\frac{\sqrt{(x-x_1)^2 + (y-y_1)^2 + (z-z_1)^2} - \sqrt{(x-x_2)^2 + (y-y_2)^2 + (z-z_2)^2}}{v} = t_1 - t_2 \quad (5)$$

$$\frac{\sqrt{(x-x_2)^2 + (y-y_2)^2 + (z-z_2)^2} - \sqrt{(x-x_3)^2 + (y-y_3)^2 + (z-z_3)^2}}{v} = t_2 - t_3 \quad (6)$$

$$\frac{\sqrt{(x-x_3)^2 + (y-y_3)^2 + (z-z_3)^2} - \sqrt{(x-x_4)^2 + (y-y_4)^2 + (z-z_4)^2}}{v} = t_3 - t_4 \quad (7)$$

The central station then uses the known positions of the four relay stations and the three measured TDOA's and solves the three simultaneous equations above to find the position of the portable transmitter.

3. Phase I Implementation

The Phase I implementation follows the components in Figure 1. The portable transmitter includes an RF carrier oscillator, a pulse generator, a modulator, an amplifier, an antenna, and a power supply. The oscillator produces a microwave with a frequency of 5.8 Ghz which is modulated with a rectangular pulse from the pulse generator with a $6\mu\text{s}$ width and a .8ms period. The signal is then amplified and transmitted through the antenna.

The relay stations consist of an antenna, an amplifier, a power supply and cables to connect them to the central station. The antenna receives the signal, amplifies it and passes it to the central station which is organized as shown in Figure 2. The signal divider divides the signal from RS2 into four signals. Three of the signals are matched with RS1, RS3, and RS4 in phase comparators. The phase difference is measured and sent to an analog to digital converter which sends the digital signal to the computer. The fourth signal is sent to a pulse detector which is connected to the computer's clock for synchronization.

4. Results

The system completed two static tests and a dynamic test (Advanced Position Systems, INC., 1996) configured in a 3.35m x 5.38m x 2.97m space. The first static test was conducted in the center of the volume and verified against an optical survey meter. The RMS error was 2.5mm in the x direction, 1.6mm in the y and 11mm in the z. The z direction had the smallest separation between relay stations. A second test was conducted near RS3 with RMS errors of 4.0mm in x, 6.9mm in y, and 18 mm in z demonstrating the

error is not constant throughout the working volume. The dynamic test was a simple demonstration of the trackers ability to track a moving transmitter.

5. Proposed Phase II Implementations

One of the goals of Phase II is to allow multiple users. Three methods are proposed for a multi-user environment; time-division multiple accessing (TDMA), frequency-division multiple accessing (FDMA), and code-division multiple accessing (CDMA). The CDMA method has the additional advantages of reducing the effects of outside interference and multi-path signals and its multiple-frequency bandwidth helps solve any phase ambiguity.

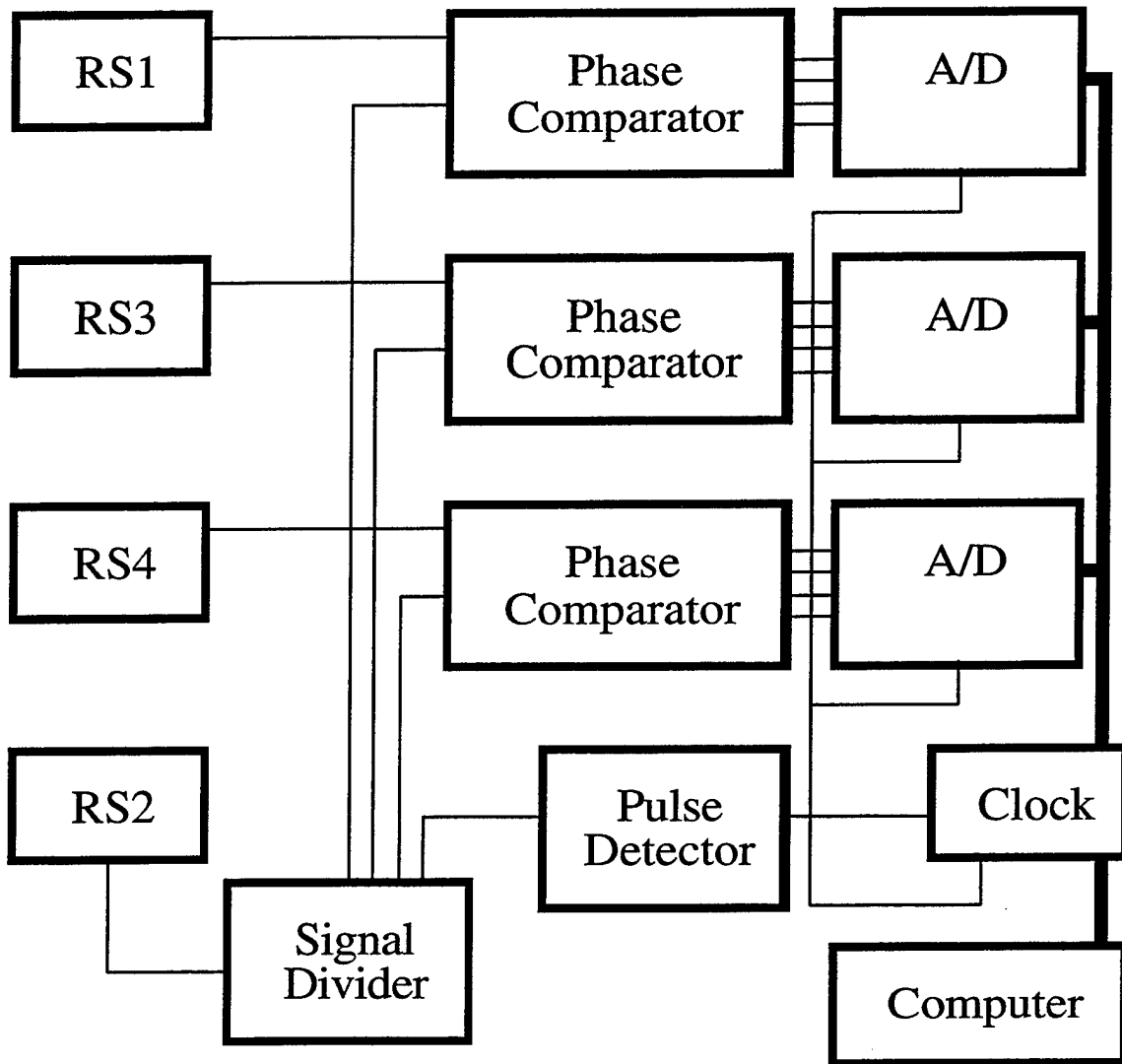

Figure 2 Block diagram of Central Station (Advanced Position Systems, Inc., 1996)

III. TRACKER ANALYSIS METHODOLOGY

The methodology presented here is general enough to be applied to a wide variety of applications but it will be discussed with an emphasis on the needs of a VE tracking analysis system. Much of the methodology will seem familiar to anyone who has done any modeling or simulation in a variety of different fields. It is suspected that most individuals approached the problem in the same way this thesis began. It would be desirable to have a simulation of this system or phenomena without regard for many of the considerations presented here until it was necessary. The goal is to lay out a plan for attacking these kinds of problems with all of the parameters considered up front.

The graphic of the methodology in Figure 3 has been laid out for a particular reason. It could be stretched out into a purely linear fashion as noted by the connecting lines. The question should be determined before the models created down to the final rendering of the simulation for viewing. The graphic is presented with three top level areas to give them equal importance and to highlight the reality that decisions in any category will affect the options available in the other. The hope is to prevent getting to the final rendering and realize that a better question could have been asked in light of the options available. The fourth category, other considerations, is tied to all of the other sections and offset. While these considerations will be discussed last, they must be outlined from the beginning. Again they will affect decisions made throughout the rest of the process and the reality is they may represent the deciding factors in the other areas.

The methodology is also designed to be iterative. Historically, many of the systems modeled required large computer system days and longer periods to complete simulations. The result is a tendency to work linearly. With the constant increase of computing power, each phase of development has benefitted. Being able to develop in more interactive environments allows the individual processes to see more creativity. Eventually, a single

environment, or a group of integrated environments will allow the entire process to become interactive and encourage constant refining of the entire problem from question asked to manor of display.

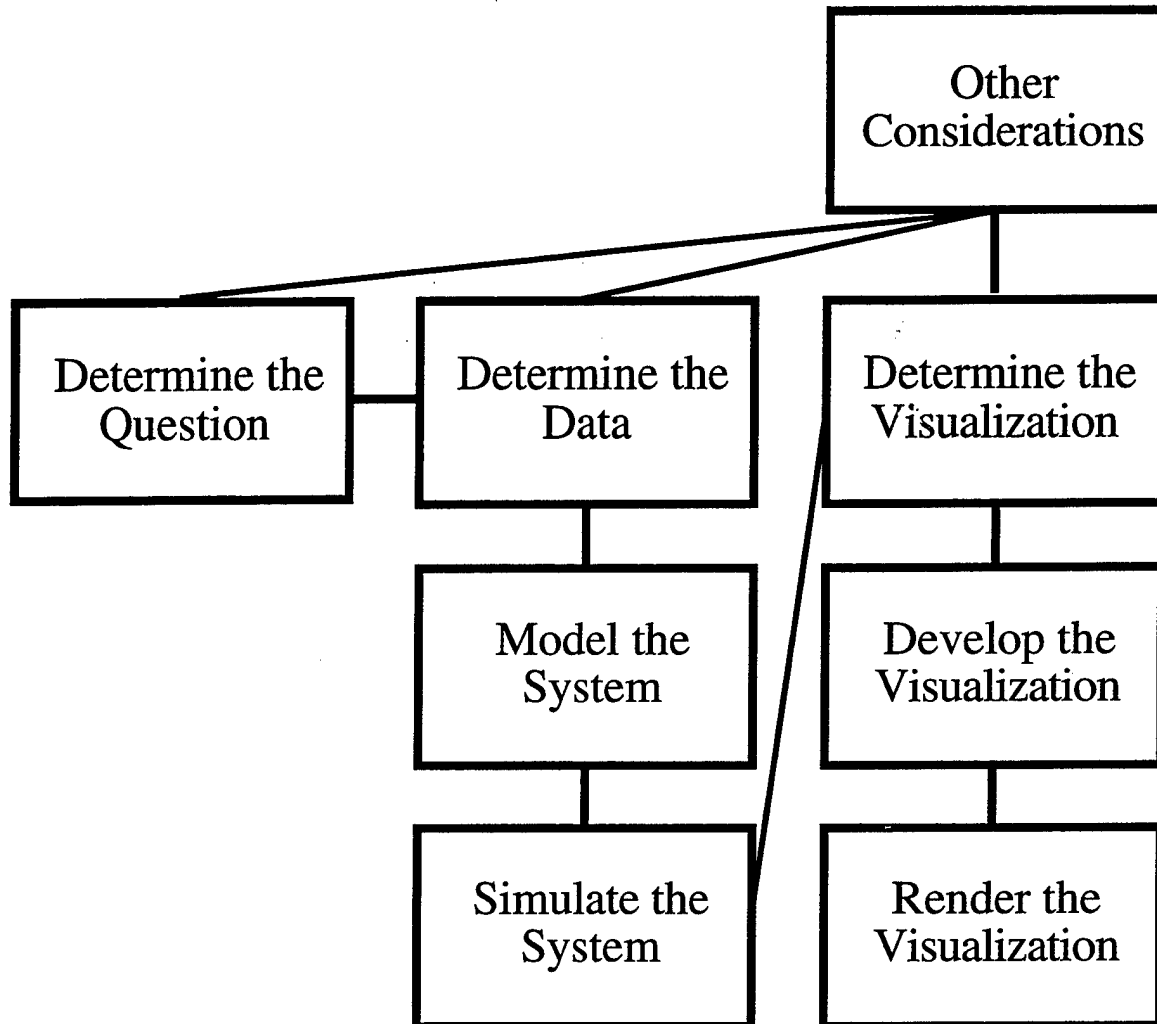

Figure 3 Block diagram of Methodology for analyzing tracking systems

A. DEVELOPING THE QUESTION TO ASK

Because some questions appear naturally within a problem or seem obvious, the difficulty in developing a good question can be obscured. It is not possible to talk about developing questions for all of the kinds a problems that exist. This section will focus on

the evaluation of tracking systems and making use of the framework described in Chapter II.

First a short discussion on what is meant by position with respect to VE. One of the goals of a fully immersive VE is to properly display on some form of view screen what a person would see if what is being displayed really existed. This is only one part of VE but this is not intended to be a philosophical discussion on what is required to have a feeling of 'really being there' or 'Presence'. For a human this means providing a six degree of freedom position of the eye (and the view screen) within the virtual environment to the computer generating the view on the screen. These six degrees are an x, y, and z position in 3D space and the three Euler angles representing orientation. Quaternions are another popular way of describing orientation which have four variables, however they are not independent so there are still only three degrees of freedom for orientation.

Tracking for VE is not limited to tracking the eye so that a view can be provided, it is just the first and most common use of tracking for VE. If the desire of the system is to allow the user to see and use their hands within the environment, the hands, fingers, and joints must be tracked. Of course each of these parts do not require six degrees of freedom tracking. It is often convenient and desirable only to track how a part moves relative to another part. Certain real objects might be used and tracked in the real world and displayed in the virtual world. If it is a heavy ball that can be rolled around the floor, only two degrees of freedom are required to tell where on the floor the ball is located since the vertical position is already known (on the floor). Since it is spherical, measure of orientation may not be required either.

While at most the above six parameters are required to describe the location of a single rigid body in 3D, each also has a velocity (angular velocity for orientation) and acceleration (angular acceleration for orientation) providing 12 other parameters which may be desirable to measure. Inertial systems do not measure position at all. They measure

the acceleration parameter which is then integrated to get a velocity which is integrated to find the position. Of course this method of measuring position has two inadequacies: (1) An initial velocity and position must be known by some other method and (2) Any error in the measurement of acceleration is magnified producing greater errors in the final reported position.

Emura and Tachi(1998) describe a positive reason to measure these other parameters. There are two basic phases in a VE system. First, the positions are measured and reported to the computer system. Second, the computer system must use the information to render the scene. Both phases take some finite amount of time. No matter how accurately (even with zero error) the position is reported or how well the view is rendered it will be drawn some time later than it actually occurred resulting in an error of the position seen. Emura and Tachi attack this problem with respect to the angular position of the head since it seemed the more critical to the VE illusion.

Emura and Tachi's objective was to combine a sensor of angular velocity with absolute orientation to compensate for the delays in measurement and rendering. The single integration required maximum-likelihood estimation, which is the basis of Kalman filter theory. This dual sensor system provided both the accurate initial position and a velocity for the integration which eliminated the problems of a purely inertial system as mentioned above. More importantly, using this prediction method, the computer receives an estimate of the position for when the computer is done rendering resulting in a more accurate view than previous systems.

This multi-sensor system adds another dimension to analyzing VE tracking technologies. Tracking other objects and tracking the head for presenting graphic views have already been described. Each technology can be analyzed on how well it performs certain aspects based on the intended use which widens the range of what is acceptable performance. As system integrators put the systems together, the entire system can then be

analyzed with respect to the needs of VE. Of course, just as quantifiable measures for what is acceptable for head tracking are still being researched, research must tackle the questions of how accurate the other parameters must be measured for their intended purpose.

While exact answers are not known at present about how well a system must operate, the framework still provides plenty of questions to be explored. Several kinds of comparison could be used, either between the relative performance of separate systems or between a system under different conditions or configurations.

B. WHAT DATA ANSWERS THE QUESTION

Deciding what data answers the question is another area where previous work might suggest this is an easy decision. If the question revolves around temperature in a volume space, then the model and simulation should provide the temperature throughout the volume in question. However, this kind of simple relationship between question and answer is a result of limiting questions to the kinds of answers that have been previously visualized. As the system becomes more interactive and the ability to visualize complex data sets of different data types, more complex questions can be developed. A balance must be struck between providing the minimum data required to speed up the computation and providing excess data to allow a more free form exploration of the system being analyzed at the expense of computational time. Focus on the known relevant data with an eye towards expanding the system to get a wider view.

The desired method for creating data is through modeling and simulation. While direct experimentation with the technology is necessary for developing the models, it does not provide the flexibility for allowing many different individuals to test the technologies against their specific needs.

First, the difference between the model and the simulation is explained. A model is an abstract representation of something. A model can be a scaled reproduction (smaller or

larger) of the original object. In physically based modeling, which is the most applicable to the tracking technologies, modeling usually involves a mathematical representation of the objects and their effects on other objects. These mathematical representations may be taken from theoretical formulas or from formulas fitted to measured observations. Similarly, more abstract concepts from subjects like economics can be observed and statistically modeled.

The goal of the model is to behave like the thing it is modeling under certain criteria. Scale models are often created just to look like the original object. A picture of a model airplane without any other objects to give reference to size can be indistinguishable from the real airplane. On the other hand, the scale airplane does not behave the same way as its larger brethren in a wind tunnel at scaled air speeds. The air the model passes through cannot be scaled and is the same as the original aircraft's air. Other formulations have been computed from observed comparisons between the smaller model and the original so that the model can be used to predict the behavior of the real aircraft.

Once a model is created, then it can be used in a simulation. The simulation can be like the model aircraft in a wind tunnel. For most of the models here, they will be used in computer programs that vary different parameters to measure how they affect the target parameter(s).

1. Determine the Model of the System

An ideal method would be a system in which a user could model the environment and purpose for which the tracker would be used. Models of each of the tracking technologies would be available for selection and trial before setting up a real experiment. This section will lay out a high level model for analyzing all of the tracking systems.

While four different technologies were described as being used for tracking in VE and two others that were not, there are only two sets of physical properties that need to be considered. The science of mechanics covers both the mechanical trackers, hence the name,

and the audio trackers since audio is mechanical wave transmission. Electromagnetic (EM) properties cover the optical, magnetic, and the RF trackers since they all represent different frequency spectrums of the entire EM field.

Figure 4 is a high level view of all of the portions of the environment that should be modeled with respect to mechanical and electromagnetic properties. The environment is divided into three areas, objects, atmosphere, and other emission sources.

Objects in the environment covers just about anything that might exist in the environment. This includes the object being tracked. Each has some mass and volumetric extent. The object's mechanical properties also include how it transmits and reflects mechanical waves and if it is a source of mechanical waves. Similarly, the object has

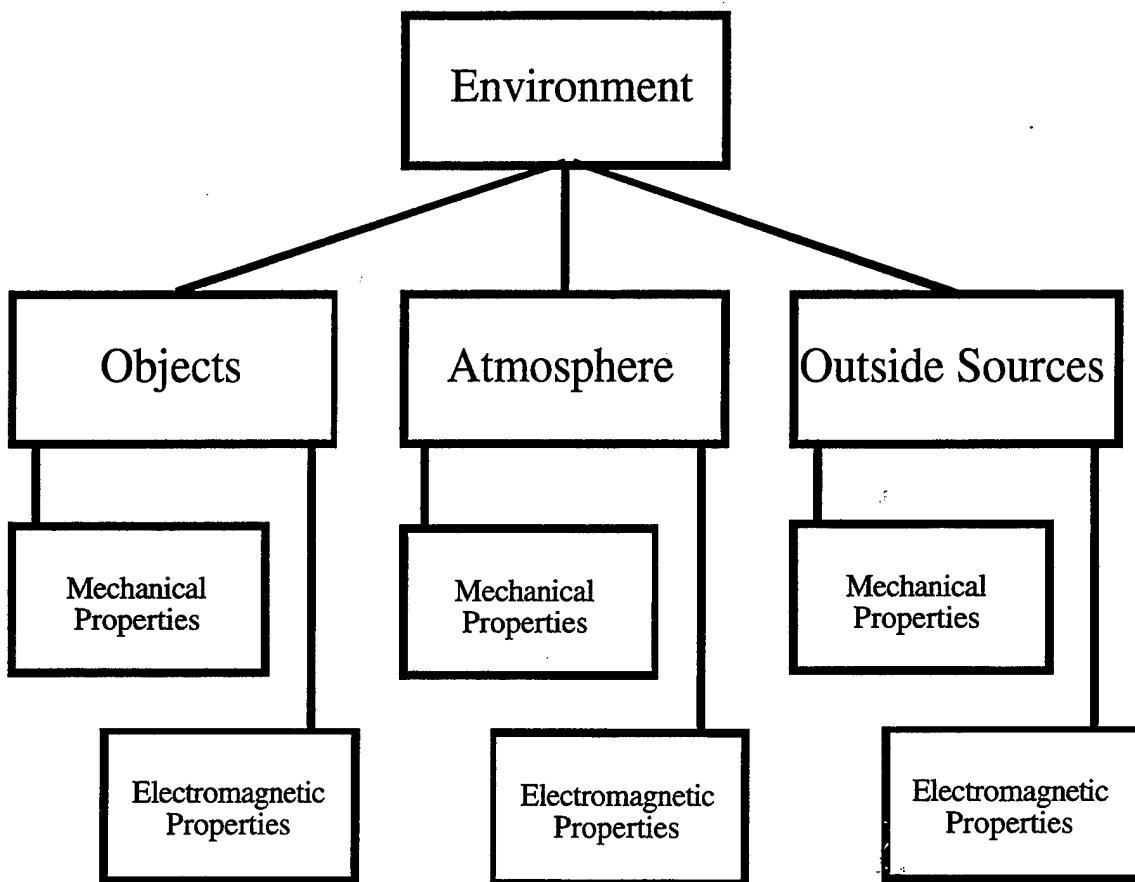

Figure 4 High level model of environment for tracking systems

transmission and reflection characteristics with respect to EM fields as well as source characteristics. The rendering of real scenes for computer graphics is based on a variety of models that are concerned only with the visual spectrum of the EM field.

The atmosphere is separated from the other objects since it represents the primary transmission medium for all of the systems except for the mechanical system. The properties modeled are essentially the same as other objects. It also has the advantage of being consistent among most of the models that would be developed, so once the atmosphere model was completed and tested almost everyone else would be able to use the same model.

The outside sources element recognizes that the environment modeled will be limited to the immediate volume space within which the tracker is being used. Other emission sources represent all of those objects outside the environment that have emission properties that can interfere with the tracking systems. This is the most difficult to model for different environments since it will be the most likely to vary. Also this model will have to be based on measured data. Hopefully the environment chosen will have minimal external emissions or the option of modifying the environment to shield from the external emissions.

Modeling the environment for a specific test will rely primarily on the user who is setting up the simulation. The modeling of the tracking systems should be simplified since once an accepted model appears, it can be reused.

Figure 5 outlines the model of the tracking systems. The three primary components, the emitter, the sensor, and the calculation package, each have mechanical and electromagnetic properties like all of the other objects placed in the environment. The additional properties might be considered as part of the other modeled characteristics but are separated for emphasis. The emitter will have an electronics package that creates the signal which will be transmitted. The sensor has an electronics package that senses the signal and turns it into measured data. The measured data is then sent to a calculation package, usually

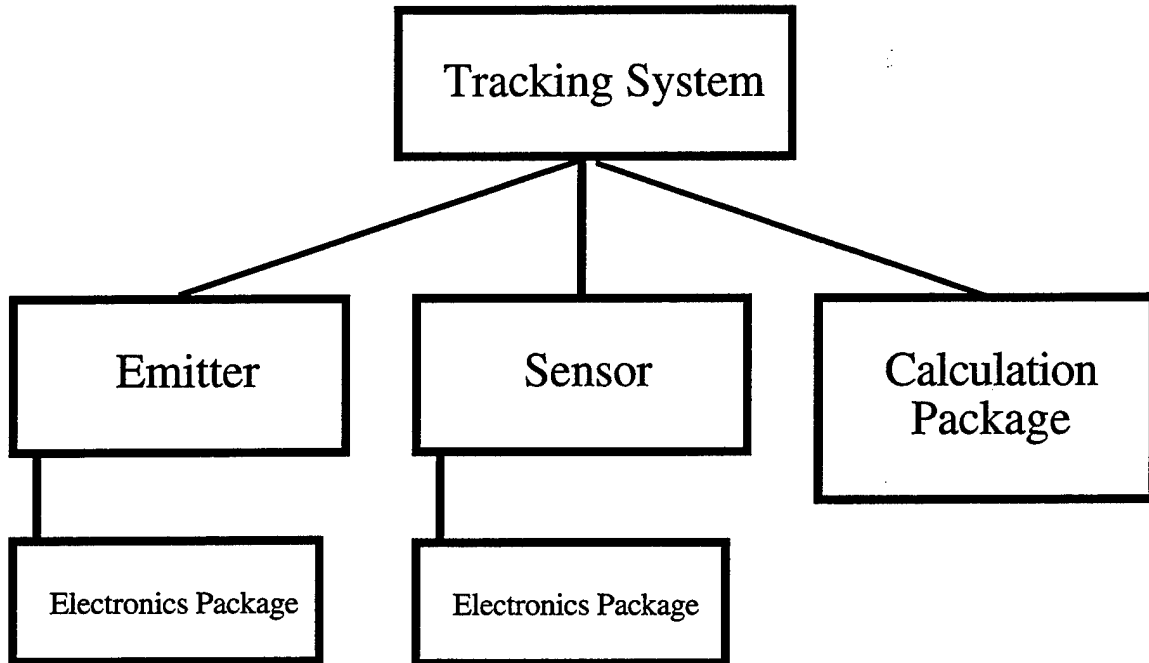

Figure 5 High level model of tracking system

a computer, which then has a model for calculating the position of the tracked object.

These high level outlines do not provide what is necessary to implement a simulation yet. They need to be turned into mathematical models which can be programmed into a computer. Once a mathematical model is created and implemented it also requires verification. This can be one of the most difficult portions of modeling since exhaustive experimentation may not be available.

A completely modeled system as outlined above would provide great flexibility for exploration of the systems. However, there is neither the computer power present nor the complete physical understanding to implement the system as described above. The description is not useless, though. It provides an outline so that individual portions can be attacked with regard to the questions developed in the last section. As more of the portions have models and as computer systems continue to develop, the ideal system might come about.

2. Determine the Method of Simulation

The method of simulation will be tied to the type of models created. Conversely, if a particular type of simulation is desired, appropriate models must be created. This portion will be primarily concerned with using computers for simulation.

When simulation is mentioned, it is often connected with varying time and observing how a model develops over time. Time does not need to be a consideration at all. The goal is to produce data relevant to the question asked. Simulation is simply putting a model through tests and recording the data it produces.

For the tracking systems, a couple of different simulations might appear depending on the question. Using the ideal system above, it would be possible to reproduce an experiment that is just like the real system being used. A modeled tracked object could move through the environment and the system would respond just like the real tracking system. Of course this would not necessarily answer the desired question.

While the modeling portion focused on the objects and behaviors being modeled, the simulation focuses more on answering the question asked. To answer it, the simulation varies the input parameters of interest and feeds them to the model. The simulation then records how the model responded. Both the inputs and the outputs represent the relevant data to answering a question.

C. DECIDING HOW TO REPRESENT THE DATA

The next question to answer is how to display the data results of the simulation. The display, of course, depends on the question that is asked. If the question is simple; "Does the tracker provide 100% coverage of the desired volume at the required accuracy?", then the computer can check the data and either display 'yes' or 'no'. It is possible that no configuration meets the needs. While simply reducing the percentage of desired coverage might fix the problem, it introduces new problems. If only 70% was the chosen number, the

test could pass but the inaccurate space might be in the center of the working volume. In some cases this may not be an issue. But if it was an issue, the computer would not be aware of the issue or be able to respond appropriately.

The computer can only check the questions asked. As the questions or trade offs between accuracy and usefulness become more ambiguous, it becomes more desirable for the user to look at all of the data and answer the trade offs manually. Of course, looking at a blur of numbers can also disguise the information desired. Developing ways to display this data in which so much effort went into creating is the focus of this section.

Even though we navigate daily through a perceptual world of three spatial dimensions and reason occasionally about higher dimensional arenas with mathematical ease, the world portrayed on our information displays is caught up in the two-dimensionality of the endless flatlands of paper and video screen. All communication between the readers of an image and the makers of an image must now take place on a two-dimensional surface. Escaping this flatland is the essential task of envisioning information--for all the interesting worlds (physical, biological, imaginary, human) that we seek to understand are inevitably and happily multivariate in nature. Not flatlands.

Edward Tufte's(1990) opening paragraph to Envisioning Information succinctly tells the problem of developing an appropriate visualization of many different forms of data. While research continues in the development of 3D display systems, the majority of the audience through the near future will still rely on printed material or flat computer displays via computer networks. Even with the advent of common 3D displays the theories and techniques described by Tufte will still apply.

First, Tufte's theories on visualization plus some of the challenges of visualization research will be considered in the next two sections. The last section will focus on rendering this visualization. While the visualization and the rendering may often be tightly linked and one determines the other, an attempt should be made to consider them separately.

1. Developing the Visualization

Developing the visualization of data should be the most important part of any scientific endeavor. This is the means with which all of the other work will be communicated. The best of modeling and simulation will be hidden by a poorly designed visualization. On the other hand, a good visualization will help identify error within the model and simulation. Unfortunately it is often not given consideration until the end as an afterthought probably “because of the diversity of skills required: the visual-artistic, empirical-statistical, and mathematical” (Tufté, 1983).

Tufté(1983) laid out a theory of graphic information in The Visual Display of Quantitative Information. The overriding principle is to above all else, show the data. As mentioned before, a lot of hard work is lost by hiding the data. The guidelines to make this happen are to start by maximizing the data-ink ratio. Everything that is printed should have relevant data associated with it. Next, increase the data density. This is akin to taking advantage of bandwidth in traditional communication technologies. The eye can only focus on a limited area so make sure it can see as much data as possible in that area. Maps are considered the hands down winners in data density when considering the high quantity of geographic survey numbers it would take to describe what is shown on a map.

Some tools to make a high data-ink ratio and data density start with using a large data matrix. The goal is to show as much data as possible, so use all of the data. The graphic ink should vary in response to data variation. This is a way to encode more information into the data ink. Another way to encode more information is to make multi-function graphical elements. While obscure encodings can be a danger, some are only obscure because they are new. As they gain use and familiarity, they can reveal more information.

Eliminating certain elements can also improve data-ink ratios and data density. Start by erasing all non-data-ink. This includes all pieces of ornamentation that do not convey relevant information. The next element to be eliminated is redundant-data-ink. A typical bar

on a bar chart may have five different elements that all represent the height of the bar, a left and a right line, a line on the top, the shading of the bar and a number showing the value of the height just above the bar. One of the elements should be sufficient. Chart junk is the technical term for other elements intended to represent data but results in cluttering of the chart. Moire vibration is an effect caused by many patterns used on a chart that give an appearance of movement. This movement distracts the viewer from the data. Using labels is more effective and eliminates the need to look at a key to interpret the values. The grid is another element that often clutters up a chart more than it adds to information. If the grid is necessary, lowering it's density or using a lighter color will make it less distracting.

All of these recommendations for designing effective graphics are just that, recommendations. Each one must be balanced against the first element, show the data. If making any of the above changes appears to reduce the information then it probably does and should be ignored. This leads to a final portion of the theory of graphic design, revise and edit. The only way to see if a graphic is effective is to draw it, make changes, and compare the two to see which best conveys the message.

Because this methodology is primarily concerned with the simulation and evaluation of tracking systems, it is reasonable to suggest that the primary display of data will take place on a computer screen instead of on paper. All of Tufte's theories still apply and can be extended. The concept of data density even suggests that paper will be the preferred delivery method for some time to come. The video screen is limited by the number of pixels per square inch which limits the amount of data per square inch. With today's printing technology, the only limit to data density on paper is the human eyes ability to discern change.

The video screen does have its' own advantages. The primary advantage is an ability to display motion and change. This includes both navigation through a 3D data set as well as the animation of a graphic based on a changing variable. As the elimination of chart junk

suggests, just because the computer can do it does not mean it should be used in that manner. The decision maker is still, "Does it communicate the data?" While seeing an animation can be effective, seeing all of the frames of an animation laid out at one time may provide more insight even though it is static. Tufte(1983) calls this technique small multiples and considers it to have all of best elements of a good graphic: comparative, multivariate, high density, large data set, efficient interpretation, and a narrative showing shifts in relationships.

The one advantage that makes the computer screen a significant improvement over paper is its support of editing and revision. The ease that a computer brings to the editing of graphics encourages exploration with many techniques and should result in better graphics as long as the traditional theories outlined above are applied. This fact holds true even if the final graphic is still intended for paper. This is evidenced by the growth in printed material such as magazines with the proliferation of computers instead of a decrease.

2. Challenges of Visualization

This section is not a part of the methodology. It is included here because the "Challenges in Visualization Research" as described by Gregory Nielson(1996) provide insight into the visualization problem. These challenges open up some interesting possibilities into visualization beyond previous work and encourages the exploration of new techniques.

a. Information Visualization

Conventional areas such as volume and flow visualization have several well defined paradigms since they have a physically based origin in 3D space. Other areas of study like multidimensional statistical data, video and documents, and network topologies have less structure. This is the context used here for the term information visualization

which has been studied for 30 years. The challenges in developing a consistent methodology is tremendous because of the wide scope of the data and the lack of well defined problems and goals.

b. Meeting the Demands of Interactive and Collaborative Visualization

Providing an environment for exploration and discovery must allow for insight and spontaneous inspiration. This type of interactive collaboration places huge demands on systems. A multi-pronged solution to meet this demand will involve improved hardware, distributed and parallel computing, the used of multiresolution and hierarchical models, compression algorithms, and sophisticated network caching schemes.

c. Metrics, Standards, and Benchmarks

Trying to develop benchmark criteria for visualization is very different than a graphics benchmark of triangles per second and is greatly dependent on perception. Some of the questions to be measured are: How effective was the visualization tool? Did a user come to the correct conclusion?

d. The Complexity of Data Sets

Each new application area, simulation technique, or measuring device seems to usher in a new type of data grid that must be accommodated. The two general approaches are model based rendering where the data is modeled and then sampled on a standard grid and passed on to the visualization technique, and special purpose rendering algorithms for each data grid. Both are based on some form of modeling which raises the question where, when, and to what degree can the errors of the model be predicted.

e. Multiresolution Models

The benefits of multiresolution models are efficiency for data browsing and fly-throughs and for compression in data archival and transmission. The use of multiresolution models as an analysis tool needs to be explored to see how changing the level of detail may reveal something that previously went undetected.

f. Segmentation and Feature Extraction

In medical imaging, segmentation is the process of associating particular data points with a larger structure such as a bone, fat, or air. In other sciences where volume data is used, feature extraction describes the process of identifying areas of interest like a vortex core. Automatic algorithms are difficult because the local attributes are not sufficient for making global decisions. Incorporating contextual and higher level knowledge about the data and the object to be identified is required.

g. Integration and Registration

The integration of different data sets as in augmented reality where a doctor looks inside a patient at rendered data or combining PET (functional) data with MRI (morphological) data require the registration of the data sets to match. Research in computer vision and robotics should contribute to the problem of integrating live analog video, volume rendering, and polygon-based images.

h. Volume Modeling

Surfaces and their polygonal approximations are the mainstay of computer graphics and special algorithms and hardware have been developed to meet the need. Splines and other mathematical methods have appeared to model surfaces but there are no

analogous models for volumes. Scattered data models, procedural models, and parametric deformations are possible solutions to the volume model problem.

i. The World Wide Web

The ability to distribute interactive documents has staggering implications on how visualization is viewed and used. Such technologies as JAVA and VRML have great potential to make these interactive documents perform far more than the traditional paper distribution. One of the dominant research challenges of the Web at present is how to catalogue and search the textual information. The more significant research may be in how to visualize navigation through the web to all of these non textual data sets. It will be more important to have an easy way to remember how to navigate back to particular data set than to make a text query.

3. Rendering the Visualization

Rendering a visualization may at first appear to be just the act of putting pencil to paper to turn the data into the graphic designed in the last section. The type of graphic desired may also seem to predetermine how the graphic is rendered. There are in fact several options for rendering a graphic in both 2D and 3D space. Each of the options has advantages and disadvantages which affect the usefulness of the graphic.

One of the most important aspects of rendering to be aware of is that it is a representation of data just as the models above are representations of an object or behavior. In some literature, the design of the objects to be displayed are also called models. Because models of the data are being displayed, a new opportunity for error occurs. This is just like marking points on a graph. The points can only be within some error range of the actual point. Of course how these errors manifest themselves and affect the interpretation of data are the subject of experimentation.

2D computer graphics have two rendering techniques, raster and vector graphics. Raster graphics is how a TV and a video monitor work. Each pixel is assigned a color and is drawn piecewise. If a graphic is rasterized, then a list of all of the pixels and their appropriate color is created. Graphics stored in this fashion are called bit mapped graphics. Bit mapped graphics are of a fixed size. Making the graphic larger causes it to become blocky, also called pixelization. Making it smaller means some of the pixels (and the data they represent) must be ignored.

Vector graphics are based on representing all of objects of the image by mathematical formulas. A line only requires a beginning and an end. The rest of the points are defined by the equation for a line. Other objects are represented by their own formulas including free form objects which have been fitted with curved lines called splines. Vector graphics can be easily scaled without the loss of data because the mathematical representations are scalable. The modeling of the graphic visualization can be a source of error. Vector graphics are usually slower than bitmapped because of the extra calculation involved. Vector graphics must also be rasterized to be displayed on most video screens.

3D graphics is primarily concerned with the rendering of surfaces. Reflection of light off of surfaces constitutes a majority of what a person sees. Another less used method, volume rendering, attempts to render all of the data through a volumetric data set. This is a little like looking into a fog bank. Depending on the density, the fog can be seen plus objects in the fog. The denser the fog, the more defined the fog bank becomes and the more obscured the objects become. Eventually the fog looks like a solid object and nothing can be seen inside it.

Both types require that the data be turned into a model that can be rendered. How different the model of the data is from the data depends on how abstract the visualization. If the data is the surface of a chair, then a direct surface rendering should produce something like a chair. At the other extreme, if the data is represented by 3D icons, then the surfaces of

the icons must be modeled based on the parameters of the data set but will look nothing like the data. Similarly, if a volume data set represents the density of a bone structure then a direct volume rendering should look like as see through skeletal structure with the densest or thickest parts the most obvious. Volume rendering of a multivariate data set that has nothing to do with 3D space will not look like an object but should illuminate the variations within the data set.

Surface models are usually built up from polygons. Curved and rough surfaces must be approximated by more polygons. Other methods of modeling such as using splines can create more accurate representations of these surfaces. However, many rendering programs convert these models into polygon based models to take advantage of hardware acceleration which is based on polygon modeling. The renderers also make use of a range of approximations from assigning each polygon a color which results in a very angular 3D blocky look to various shaders that balance the shading across the polygon which can result in a more natural curved look. Some of the most accurate renders such as ray tracing and radiosity can result in a very photo realistic image at the cost of speed.

Volume models have not developed as they have in surface space. Most are either a regular or irregular grid of points. These points can define small volumes like cubes and tetrahedra. The points are assigned values that represent various optical properties such as color and transmission. Different rendering algorithms collect these properties by passing rays through them and collecting the cumulative color which results in an image. Speed is again the trade off for accuracy.

Since the trade offs are speed and accuracy, the question to decide which modeling and rendering method is dependent on the expected use of the image created. All of the images created must be rasterized to be displayed on screen with the inherent loss of data. Giving up some of the data which may be lost anyway can increase the speed of the rendering process. If the rendering is quick enough, there may be an opportunity to take

advantage of the video's ability to change and provide interactive views which can be explored. On the other hand, a very accurate rendering which will be slow and lose interactivity and will possibly lose data on the display can be put to paper with greater precision which is already non interactive.

D. OTHER CONSIDERATIONS

While the other considerations are outlined here last, the methodology suggests these considerations will probably be apparent from the beginning and have a dramatic influence on all of the other decisions. The developer should first look beyond the assumed limitations with the idea of creating a perfect model, simulation and visualization and then work backward toward what can really be accomplished.

1. The Audience

Considering the audience is not intended suggest making some assumptions about their intelligence and ability to understand the material presented. Some consideration may be given to the audiences experience with various visualizations since the familiar will be easier to interpret but should not limit experimentation with new visualizations. The real problem with the audience is how to get the material to them. Paper remains popular and has the advantage of working equally well everywhere except in the dark. Networks are growing exponentially more popular with the boom of the internet.

While sending any application or interactive document is possible over the network, its' usefulness is dependent on the platform it is designed for and what is available at the far end. In Computers in Physics' ninth annual software contest in 1998, the grand prize winner, two of the other four winners, and two of the six honorable mentions listed the platform the application was built on as the World Wide Web (Donnelly, 1998). These applications took advantage of platform independent web based technologies such as

HTML and JAVA. Of course when discussing simulation and graphics rendering all platforms are not equal and will place limits on what is truly interactive.

A possibility for delivering simulations that require expensive hardware to operate are Web applications. These applications provide a Web based interface for entering data and seeing the results. The data is sent back to the original hardware which executes the simulation and sends the results to the user. In this scenario, assuming that the hardware is capable of real time interactive simulation, the limitations on the far end are dependent on the amount of data that must be passed between machines and the data bandwidth.

2. The Tools Available

There is too wide a variety of tools to do an adequate discussion here. The tools fall into a several categories such as programming languages like JAVA and C++ and development environments such as Codewarrior, to specialized scientific environments such as Matlab and Mathematica, and visualization programs such as charting applications and 3D modeling and rendering applications. Because of too many choices, the real limitations on tools are familiarity by the developer and financial resources. The way to address the issue is continued open communication about how effective a tool was in getting a job done and difficulties encountered with the specific tool.

IV. ERROR ANALYSIS OF THE RF TRACKING SYSTEM

In this chapter, the methodology described in the last chapter will be used to develop an analysis tool for the RF tracking system developed by Advanced Position Systems, Inc. Only the decision making process will be described here and the actual implementation will be discussed in the next chapter.

A. OTHER CONSIDERATIONS

Because the other considerations played such an important roll in the development of the analysis tool they will be discussed first. This simplifies a great deal of the decision making process since it provides a narrow focus on the subject.

1. The Audience

The audience is intended to be anyone involved in VE research who is looking for alternative tracking systems which meet broader needs than those provided for by the magnetic systems in prominent use today. Because the system is intended to be configurable to the users situation, it was deemed that the tool must have at least the basic interactivity to change the principle set up of the RF system in a simulation and view the results. The tool needed to be as platform agnostic as possible for both running the simulation and viewing the results.

2. The Tools Available

To meet the widest possible audience, specialized applications were ruled out since they would only be useful to others using the same application. For developing the simulation both C++ and JAVA were considered prime candidates. While JAVA has the advantage of running precompiled on many platforms there was concern about the speed of

the application compared to the native compiled C++. ANSI C code can be delivered to a variety of platforms and compiled without further work. If the simulation had proven sufficiently fast then a JAVA implementation would have been tested.

While a visualization was not predetermined, it appeared from the beginning that a 3D view of the system would be required. The only way at present to develop 3D interactive views which are deliverable over the internet and has viewers on Windows, Macintosh and several UNIX platforms is to use the Virtual Reality Modeling Language (VRML). VRML comes in two distinct parts. The language is simply a file format which describes all of the objects and some simple interactions with the objects. The viewer which has a separate implementation on each platform renders the file and allows navigation through the scene. Some of the implementations also allow scripting or linking to JAVA applets but these properties are not consistent like the actual viewing of the file.

B. DEVELOPING THE QUESTION TO ASK

The goal is to provide a simple way to evaluate this RF tracking system with regard to a couple of simple needs. This model of evaluation could then be expanded to other technologies to help match the specific system to the needs.

One of the goals of the RF system is to simplify the set up and calibration of the system for use. Being able to set the system in a wide variety of patterns instead of one predefined set up adds to its flexibility. The evaluation process will allow the ability to compare several different setups and picking the best one before putting it in action.

The technology used is RF signals which are measured to determine a position. The receivers receive an alarm signal from the transmitter. The receivers could measure two different parameters. One is the exact time the alarm signal arrived at each of the receivers. This would require a great deal of extra hardware and expense to ensure that each receiver

was using the same clock. The second method involves comparing the signals received by each receiver and determining a time difference.

The time difference between each pair of receivers draws a 3D hyperbolic surface on which the transmitter is positioned. Finding the intersection of two of these surfaces reduces the transmitter's position to a line. Finding the intersection of three surfaces can reveal the 3D position of the transmitter. Note: while three receivers provide three unique time differences and three surfaces, they do not provide accurate 3D information off of the plane that they define. A minimum of four receivers is required and the fourth should not be coplanar with the other three receivers.

The accuracy of the system is dependent on how accurately this time difference is measured but is limited by the spacial configuration of the four receivers (relay stations). Since the signals being measured travel at the speed of light (3.0×10^8 meters/second) a 3.33×10^{-12} second error will result in at least a 1 millimeter error in distance. This would be a minimum error if the transmitter is on the straight line path between two receivers. Off of this path, the same time error will result in a greater measured position error.

The results of the initial tests on the RF system had already determined that the error varied depending on the location of the transmitter with respect to the receivers. The first question developed was what is the relative error throughout the target volume. Two possibilities existed which could vary the error, the positioning of the receivers and how the signal reception varied based on the different positions of the transmitter. After considering the modeling process the question was further modified to only consider the error based on the positioning of the receivers.

C. WHAT DATA ANSWERS THE QUESTION

1. Determine the Model of the System

While the last section developed a fairly well focused question, this section will first consider attempting to create the models described in the last chapter. A completely modeled system would both answer the above question and provide for further exploration.

Unnecessary portions of the model will then be eliminated for the sake of computational speed and the models required to answer the question will be presented. As discussed, consideration must be given to both the environment and to the tracking system.

Mechanical properties other than position of objects were eliminated first since the system was designed to be free of any mechanical interference. Consideration might be given to the weight of the transmitter and how it effects the users natural movement since it would be carried on the head. The phase I implementation did not suggest that this would be a significant issue. Of course, if the system was to be considered for use in an aircraft which would experience significant g-forces then it would require further investigation since the weight would be magnified and could become an issue.

Initially there was interest in the electromagnetic magnetic properties of the objects, especially at the frequency range of the system. An environment such as a room on a ship with metal walls on all sides might have provided some interesting effects with regard to multi-path interference of the signal. Unfortunately most of the mathematical models concentrated on only one aspect of a transmitted and received signal such as the power. While comparing the power in the direct and multi-path signals could be done it did not provide complete information for recreating the signal that the receiver would get. The phase, polarity and distortions in the signal caused by reflection are other parameters that required investigation.

Adapting ray tracing algorithms from the graphic community was considered a possibility. They would have required significant modification to handle the omnidirectional nature of the transmitters and receivers (though the signal strength is not constant in every direction) and phase properties would have to be added. Because of these adoptions from the visual spectrum to the RF spectrum an alternative modeling environment would be required to verify the model. Direct experimentation was not an option. The other modeling environments still did not appear to meet the requirements to reproduce the signal at the receiver as desired plus they would not have been suitable for use based on the requirements outlined under other considerations.

Had a method for modeling the environment and especially the transmission characteristics with respect to EM been achieved then models of the transmitter and receiver portions of the tracking system could be developed to interact with the transmission medium. At this point in the model of the tracking system, all that would be achieved would be a signal at each of the receivers. Because there was no way to correlate changes in the signal to error in the position the rest of the tracking system must be modeled.

The next link in the model is the electronics package of the receiver which would turn the signals into measured times, specifically the TDOA's. While there are packages for modeling electronic systems, they again don't meet the outlined requirements. More importantly, the actual electrical implementation of the system was not known (though the tracker system developer would clearly know this information). Second, real time simulation would clearly be unavailable since a 5Ghz signal would be modeled with computer systems that only run at hundreds of MHz. The third issue arose because the phase II implementations significantly altered the signals being sent and the electronics packages to interpret them.

The good news from the changes in implementation is that the errors that the system hoped to model would probably be eliminated and could be verified by the actual system.

This suggested that the error of the system caused by how well the TDOA is measured may not vary with the position of the transmitter. This is the point where the question focused on the arrangement of the receivers and how the error varied in the target volume of each configuration.

A natural model of the calculation portion of the system exists in the TDOA equations. The solution to the TDOA equations which is described in the Appendix is the same as those used by the system. Based on a position for the transmitter, exact TDOA's can be calculated. By adding a time error to the TDOA's and using the modified TDOA's in the solution calculations for position a calculated position is found. Comparing the calculated position to the original position provides a position error.

2. Determine the Method of Simulation

Based on the model and the question described above the simulation is fairly straight forward. A grid of positions are laid out in a target volume along with the positions of the receivers. For each position eight different position error calculations are made using a constant time error which is user defined. Each of the error calculations is a different combination made by either adding or subtracting the time error from each of the exact TDOA's calculated for that grid position. The resulting data is a grid position plus the largest of the x, y or z position errors.

Ideally, the analysis process would allow both user interaction and immediate feedback. The user can manipulate one receiver (either visually or numerically) and immediately see how it effects the error data in what ever format it is displayed. Unfortunately, even in a relatively small 5m x 5m x 5m space with data points at 1/2m intervals, the data set is 11 x 11 x 11 and has 1331 data points that must be evaluated in the above manner. While certain systems could handle this load in real time, the ones used to develop the analysis were not and so realtime feedback is currently impractical.

Because realtime feed back between simulation and visualization would not be available to the widest audience, keeping the simulation portion separate from the visualization seemed appropriate. This has the additional advantage that the simulation data can be used in different visualizations and the visualization can be used for different simulations if deemed appropriate.

D. DECIDING HOW TO REPRESENT THE DATA

1. Developing the Visualization

Since the device is intended to be used in a 3D environment, it makes sense to provide a 3D visualization. 2D requires the viewer to infer 3D information and thus can cause ambiguity and the ability to evaluate will be dependent on the evaluator's ability to take 2D information and mentally construct a 3D picture of the situation. 3D eliminates this ambiguity. The question also seeks a view of variation through a volume and thus implies a 3D solution.

The impossible seems desired, the ability to look through a 3D volume of data and see all of the information. Because 3D visualization is a relatively new developing field, the next section will describe several different methods of visualizing data arranged in a 3D volume and each one's method of modeling the data, rendering and potential for visualizing the position error data when appropriate. This last part in the section will outline the visualization of the error data and how it was chosen.

2. Examples of 3D Visualization Techniques

a. Interactive Volume Navigation

The Volume Navigation Application in Figure 6 was designed to allow the exploration of large complex optically dense volumes to search for relatively small features of interest. The data set should contain regions of low opacity through which to navigate. 3D medical data as used in Figure 6 is an excellent example of the type of data for which this application was designed. The hollow structures such as bronchial passages, blood vessels, or the intestinal tract serve as the regions of low opacity through which to move and allow the simulation of catheter type examination.

The rendering method is based on raycasting. A ray is cast from the viewpoint through the entire volume accumulating a color from all of the data points in the grid it passes through. This method is extremely computationally expensive for large volume sets. The heart of the navigation application is the speeding up of this computation to allow for navigation. Three things are done. First, only a small view frustum is rendered instead of the entire volume. Objects outside the view frustum are not seen. A two-phase perspective volumetric raycasting algorithm is used during navigation. This algorithm takes advantage of moving along a path and allows previous rendering to be used for subsequent renderings spreading out the value of each computation. When there is a pause in movement a more detailed rendering appears allowing inspection of the object of interest (Brady, 1998).

This application has some interesting and effective ideas to compromise between accuracy and navigation. Limiting the viewing frustum to cull what would not be displayed on the sides is acceptable but not for the near and far distances. The most applicable portion of this project would be the use of the modified ray casting in another viewer.

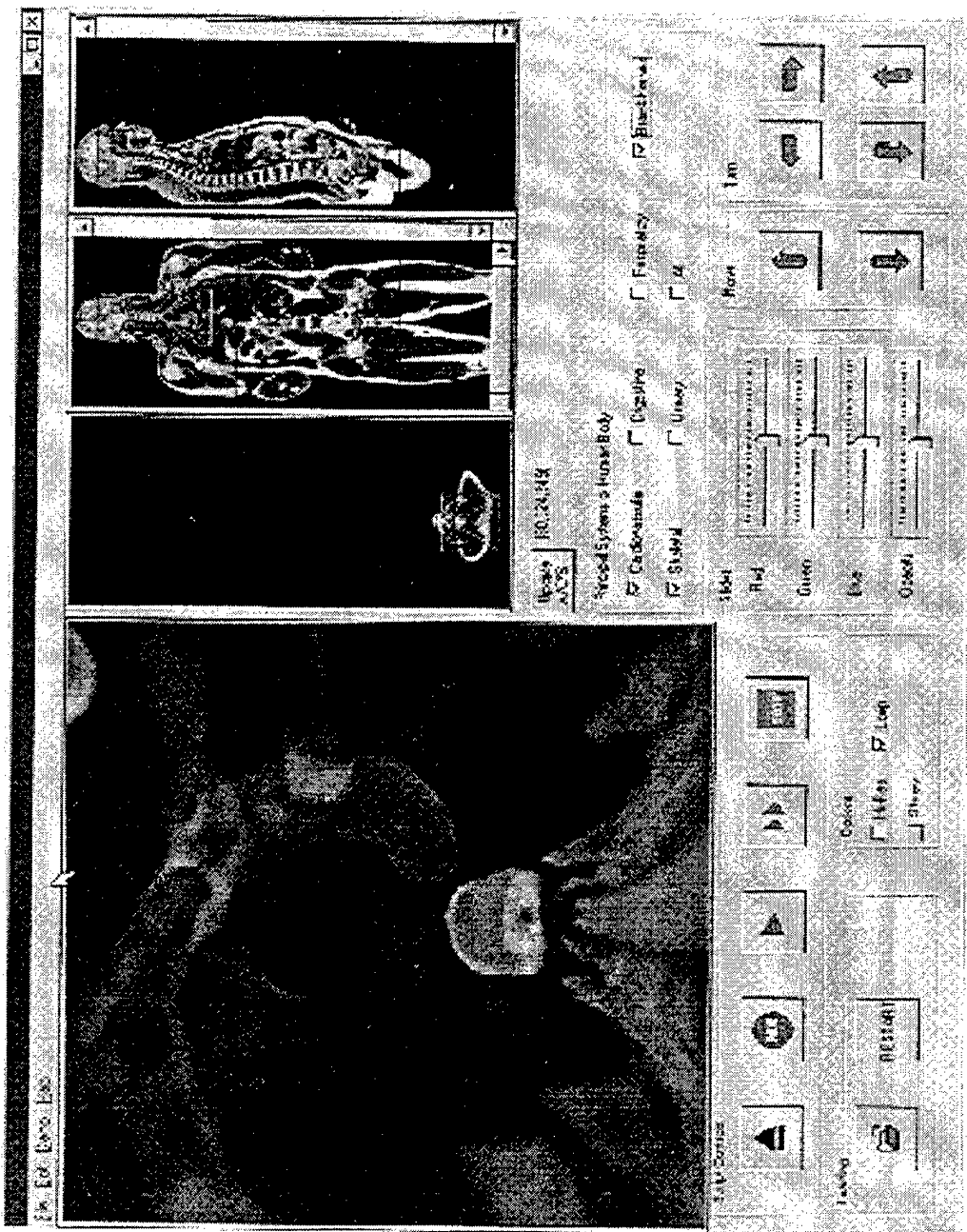

Figure 6 Screen shot of Volume Navigation Application with volume rendering of medical data (Brady, 1998)

b. Virtual Data Visualizer

Virtual Data Visualizer does not represent an example of a single type of visualization, rather it is visualization tool that can greatly enhance the understanding of what makes an effective visualization. First, it is a customizable visualization tool which allows the viewing of a wide variety of data sets. Testing with different glyphs for representing the data allows a user to quickly determine what illuminates features of a data set and what does not. Figure 7 shows a molecular dynamics simulation and Figure 8 shows a computational fluid dynamics simulation. What makes VDV unique is it is a VE system. The user views the data in 3D and is able to interactively customize the system without leaving the 3D environment with 3D menus similar to a traditional windowing system. VDV also uses the Ascension Bird to track the head mounted display and 3D mouse (Teylingen, 1997).

Using such a 3D environment goes the final step toward eliminating 2D ambiguity. Of course its use is extremely limited until 3D displays become more common. This example also demonstrates using 3D surfaces for a volumetric data set. As a result more traditional rendering options can be used.

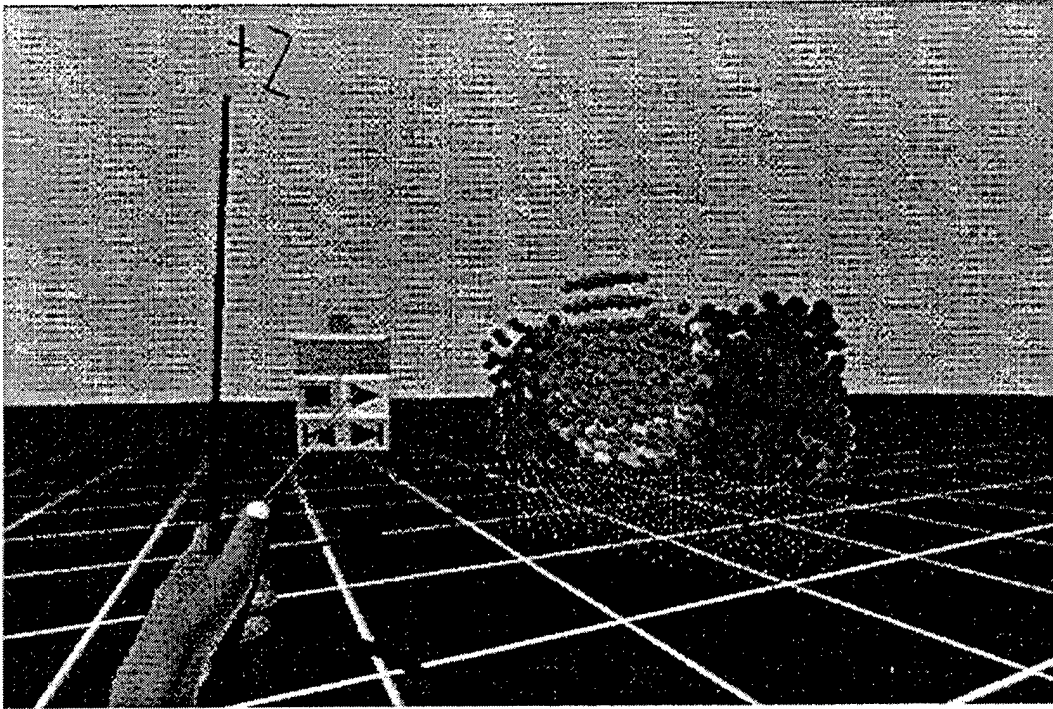

Figure 7 Molecular dynamics simulation viewed with Virtual Data Visualizer (Teylingen,1997)

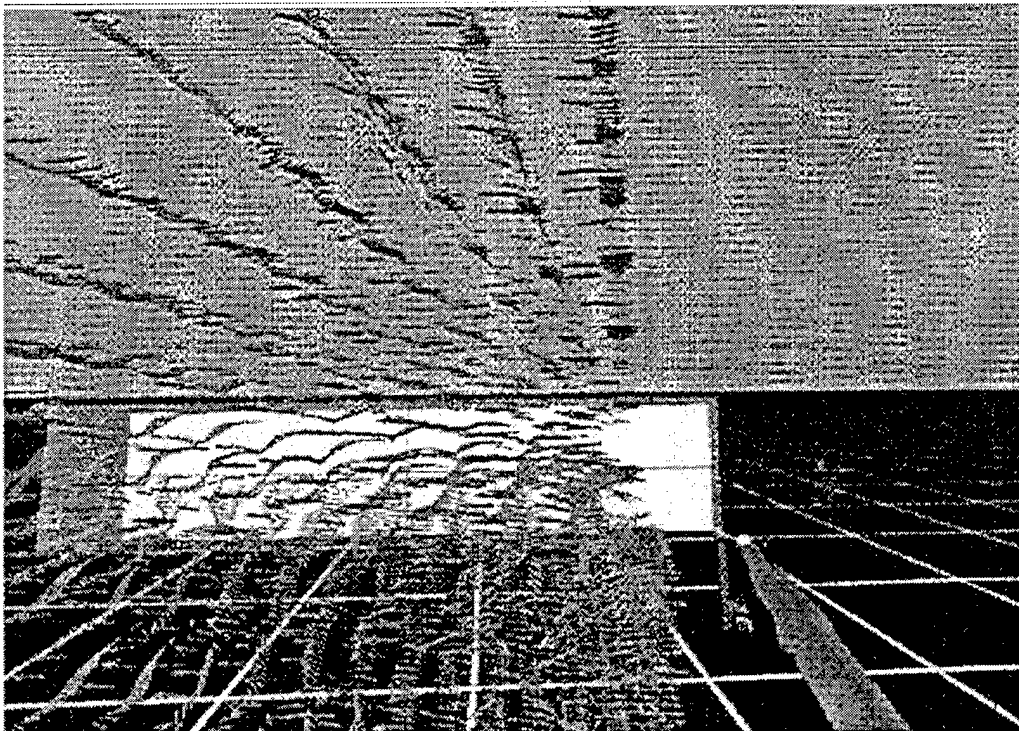

Figure 8 Computational Fluid dynamics simulation viewed with Virtual Data Visualizer (Teylingen,1997)

c. Interval Volume

Figure 9 shows four examples of the use of interval volume. Each is similar to a traditional technique, solid or isosurface, transparency, cut away, and a combination of transparency and cut away. Each of these would normally require a different renderer but

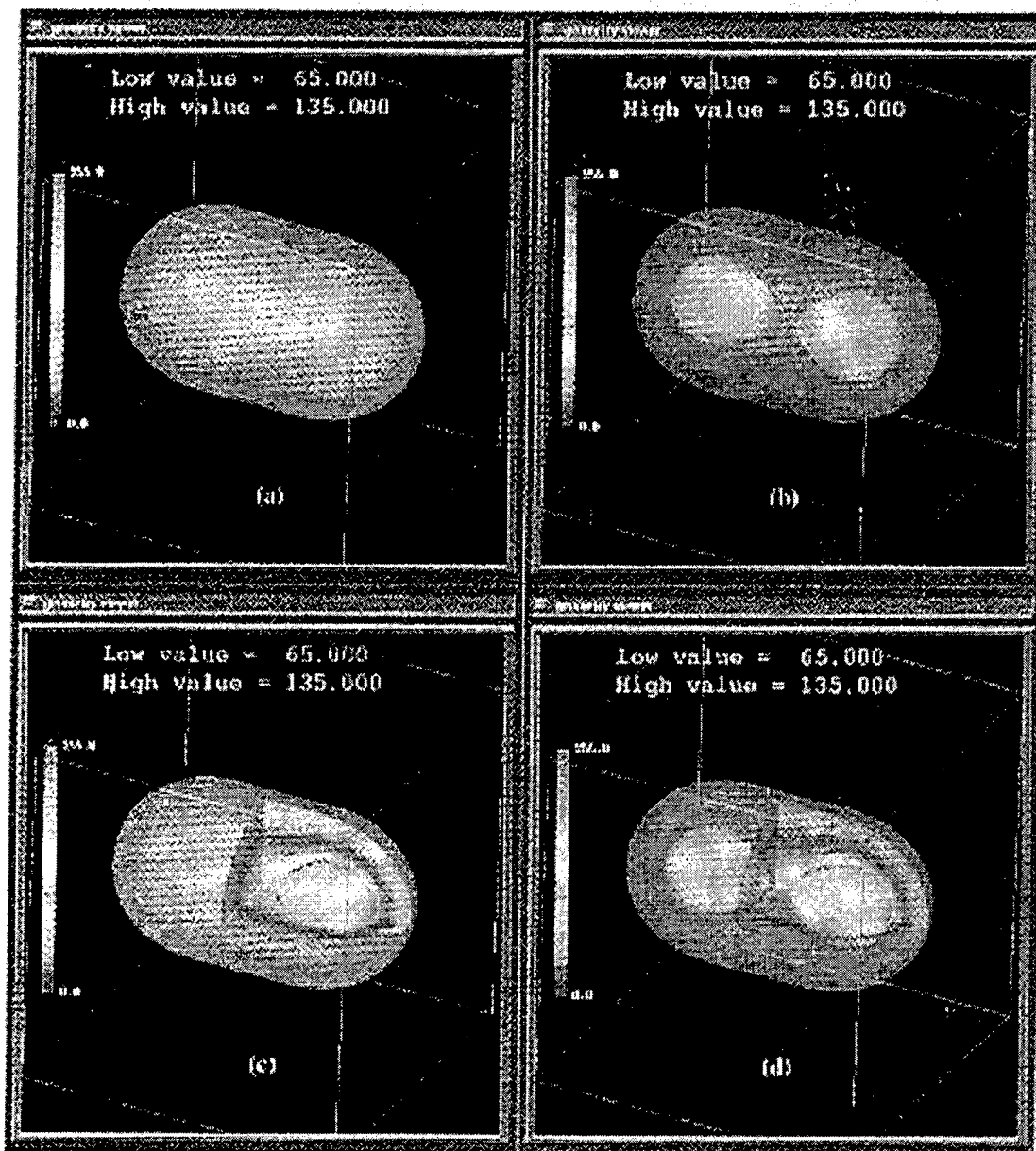

Figure 9 Four different interval volume renderings of a Hydrogen molecule probability density (Fujishiro, 1996)

interval volume allows all of them. Interval volume is similar to both surface fitting and direct volume rendering techniques and tries to inherit the advantages of each. Because of the nature of sampled or simulated data sets, there may be structural ambiguity which distorts surface fitting giving an inaccurate perception or hides relevant data. Interval volume uses a user definable range for the surface fit and extracts a volume from the data set instead of just a surface. Traditional volume rendering like ray casting is extremely slow. By extracting a portion of the total data set the rendering is sped up to real time interactive speeds (Fujishiro, 1996).

Using the interval volume method has a great deal of potential for use with the position error data set. The only problem might arise from how many interval volumes can be inside each other without obstructing the view. This maximum number of layers would be the most levels of variation that could effectively be seen. The volume extraction portion could also be separated and used with other rendering systems.

d. High Accuracy Volume Renderer (HIAC)

Most of the volume rendering techniques discussed concentrate on simplifying assumptions or approximations to deal with the geometric configurations and complex mathematics of the absorption-emission integrals in hope of speeding up the rendering. These can cause errors to appear in the renderings. In data sets that are adaptively refined, the cells of the grid are smaller by many factors when the data changes rapidly. It is possible that these methods will miss the small cells. The high accuracy volume renderer is developed without any of these approximations for the purpose of creating benchmark images with which to compare other approximation rendering systems for accuracy. The HIAC system is based on the absorption plus emission optical model and uses a cell projection method to accumulate the image, as in Figure 10. When available, exact solutions for differential equations and interpolations are used. Subpixel accumulation by splatting is

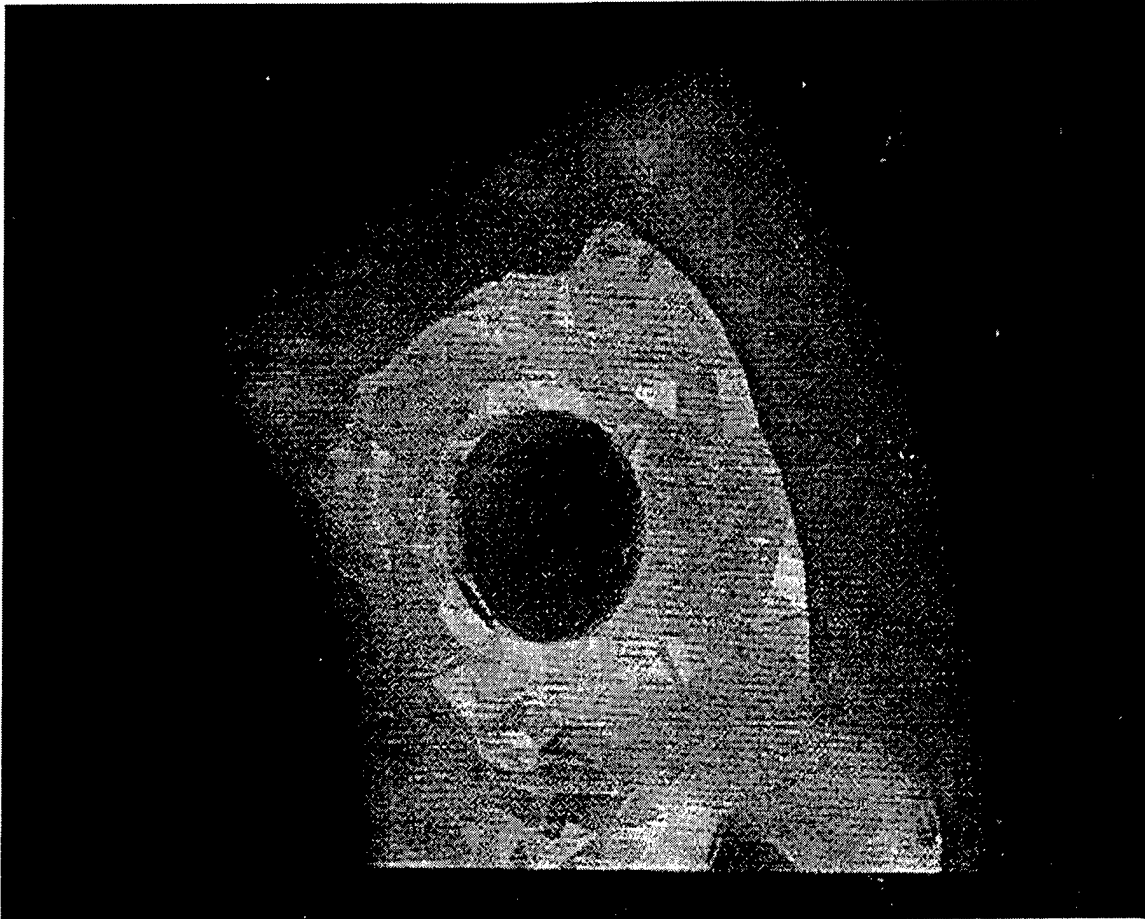

Figure 10 High accuracy volume rendering of coolant flow inside a component of the French Super Phoenix nuclear reactor (Williams, 1998) used to avoid sampling error (Williams,1998). As suggested, this tool could be used to verify other renderings of the data but does not meet the navigation needs required for the visualization being developed.

e. Multiresolution Volume data

Figure 11 shows different resolutions of isosurface visualization and direct volume rendering. While the visualization methods are familiar, the form of simplification to make the visualization interactive does not focus on the rendering algorithm but on the data set itself. A coarse to fine (original data set) and a fine to coarse method are used to create a fine grained sequence of tetrahedral meshes which are stored together. The user can then

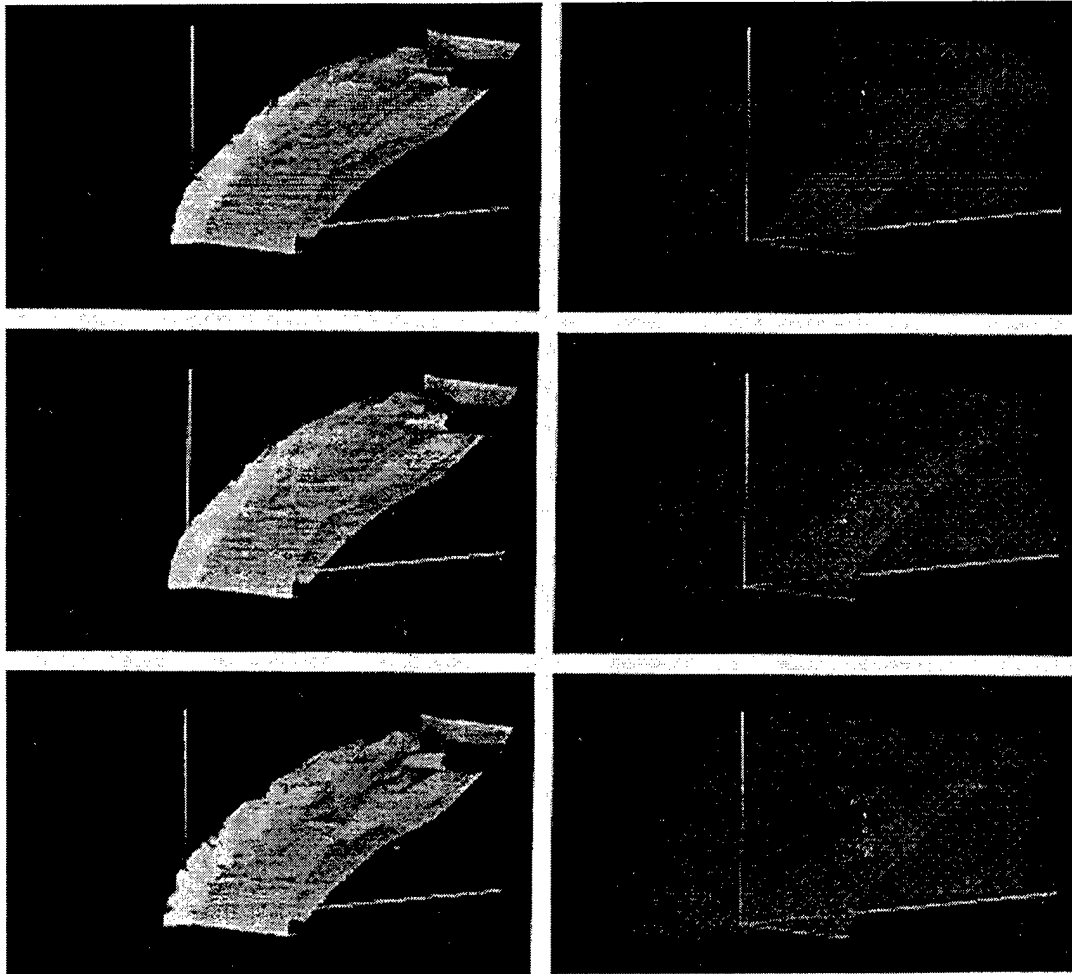

Figure 11 Isosurface visualizaion and direct volume rendering of the VlutFin dataset at three different resolutions (Cignoni, 1997)

interactively scale between the resolutions for quick navigation on computer systems with a range of rendering capabilities and for high detail to observe specific objects (Cignoni, 1997).

This method provides assistance for reducing the load on the renderer but it does not help reduce the data creation. It also has the effect of increasing the total amount of data for the multiple resolutions which increases the network load. It may be possible to modify the storage of the multiresolution data so that only the coarser (smaller data sets) are sent over a network depending on available bandwidth.

f. Tracking 3D Features

The tracking of 3D features is another important tool that is being developed for visualization. Again this tool is not dependent on the rendering method. Figure 12 shows several frames of data from a computational fluid dynamics simulation which contains vorticity. The goal is to identify reconnection events between vortex tubes. By

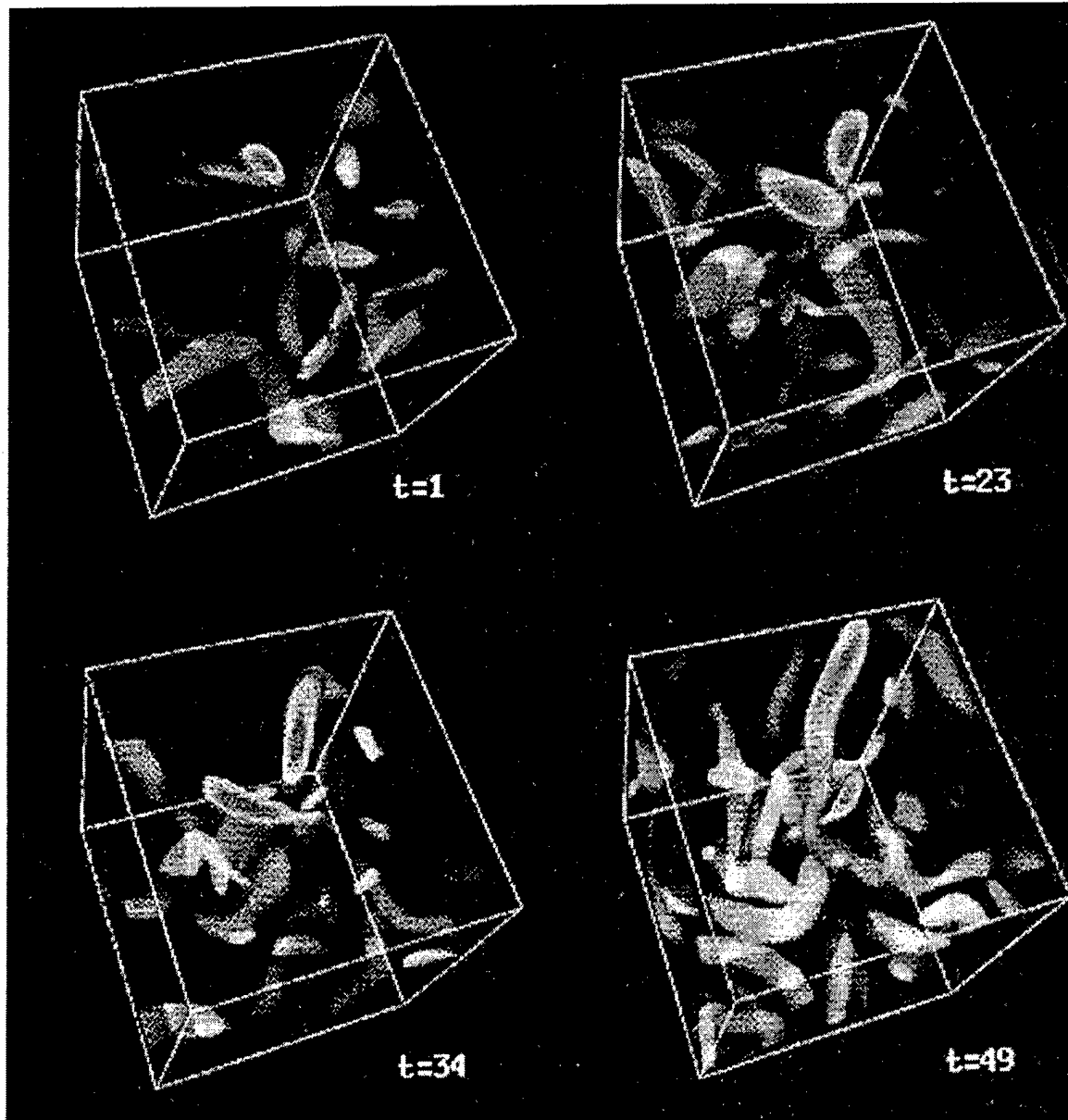

Figure 12 Several frames from a Computational Fluid Dynamics simulation showing vortex tubes (Silver, 1997)

tracking amorphous volumes from frame to frame vortex tubes of interest can be highlighted. In Figure 12 the tubes of interest are colored (which can not be seen in this reproduction) while all of the others are rendered in a transparent gray. In this way the reconnection event can be extracted from this huge data set which would not be possible by a normal rendering of the data (Silver, 1997).

At first, the sort of discrete objects that are extracted by this system do not appear to apply for the position error data. However, there are some singularities in the computations and areas of extreme ambiguity that are normally lumped with other low accuracy data that might be interesting to track as the positions of receivers change. That is not the primary goal of this visualization.

g. Gaseous Rendering

Figure 13 is another example of using several forms of volume rendering at the same time to take advantage of each one's characteristics when studying a set of data. The four renderers used in the figure are the gaseous renderer, transfer function renderer, template renderer, and the splat renderer. The data visualized is the density in an axially symmetric circular jet, another computational fluid dynamics problem. The gaseous renderer is considered the photorealistic, most accurate, representation of the data. It is also able to combine multiple data sets in the same image. In this image, the density data is volume rendered while the Mach number controls the coloring through the use of solid texturing. The transfer function renderer is based on ray casting. It takes about half the time of the gaseous render and is intended for the interactive design of the transfer functions used in the gaseous renderer. The third render is based on a simplified version of ray casting. All of the rays are parallel, instead of a perspective view, and a template is calculated for one ray that can be used for all of the other rays. The result is a ten fold acceleration of rendering to allow some interactivity. The last renderer, called a splat renderer, greatly reduces the data to

be rendered and takes advantage of hardware texture mapping to further reduce the rendering another 10 fold which allows animation (Yagel, 1995).

The gaseous renderer is highlighted here because it provides another rendering option. It is of course too slow for the navigation requirements of this system.

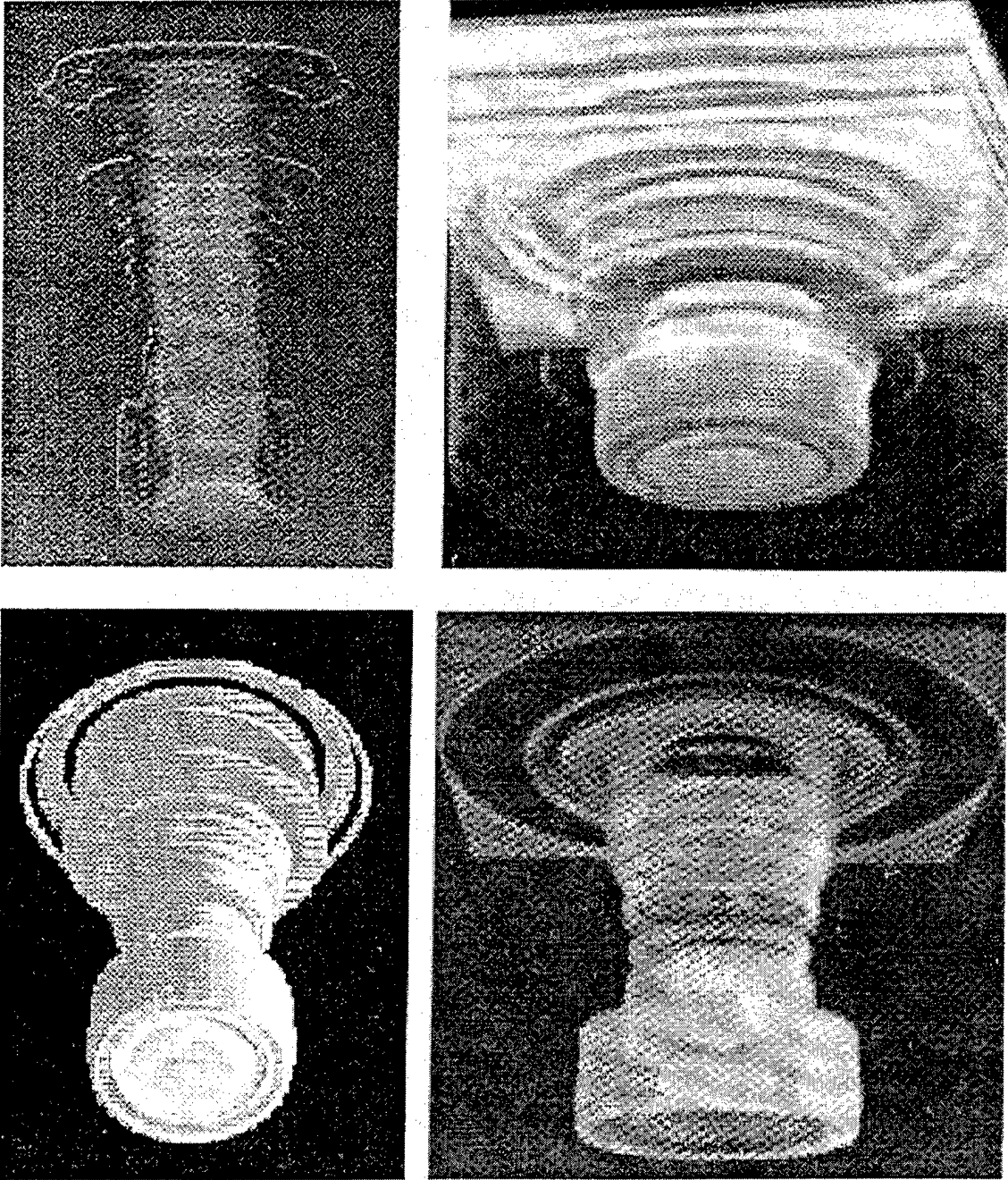

Figure 13 Computational Fluid Dynamics simulation of axially symmetric jet (Yagel, 1995)

However the entire tool provides a method of verifying some of the more navigable rendering methods.

h. Iconic visualization

Figure 14 and Figure 15 both represent the answer to the question if nitrogen oxide formed in a chemical reaction would it flow upward or downward in the atmosphere. The regions of interest have a reaction speed higher than 50% of the global maximum. In Figure 14 the velocity at every grid node within the region is shown. In Figure 15 a more iconic view is shown. The centroids and second moments are mapped to the solid ellipsoids. The arrow icon from the ellipsoid shows the mean velocity of the region and the

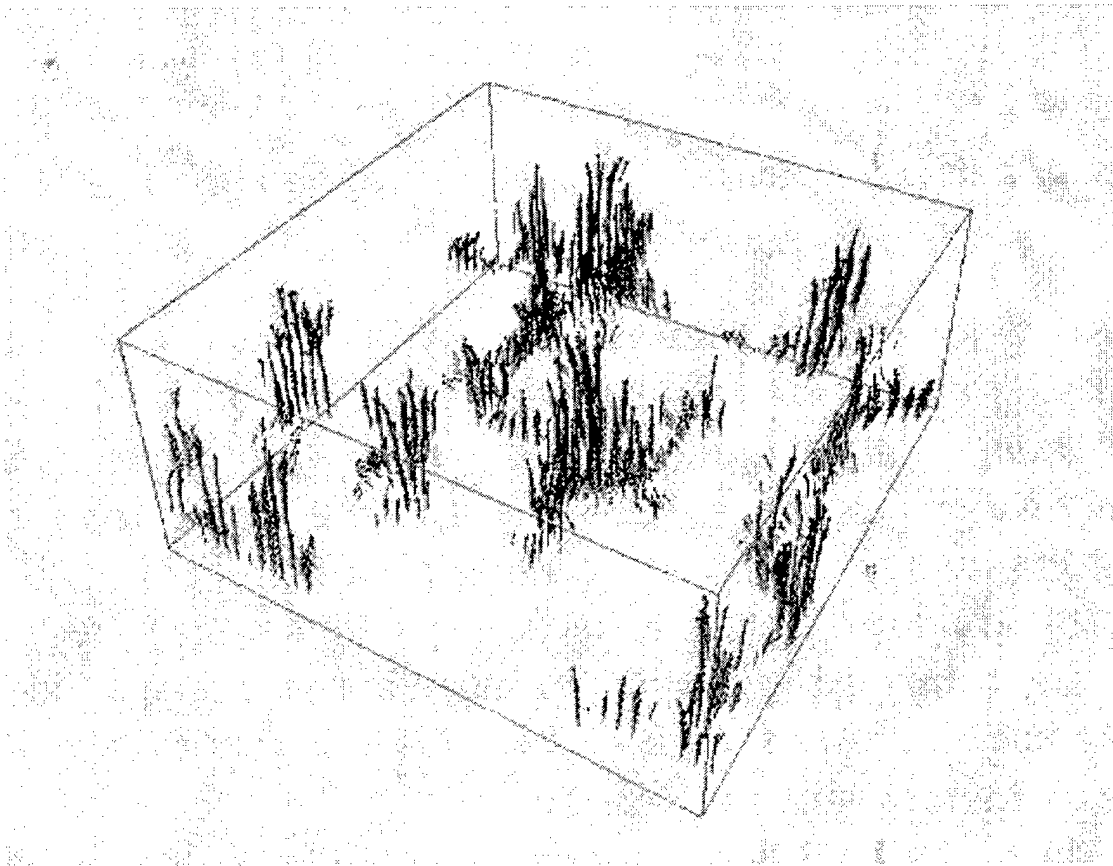

Figure 14 View of data showing the flow of Nitrogen Dioxide in a chemical reaction at each point (Walsum, 1996)

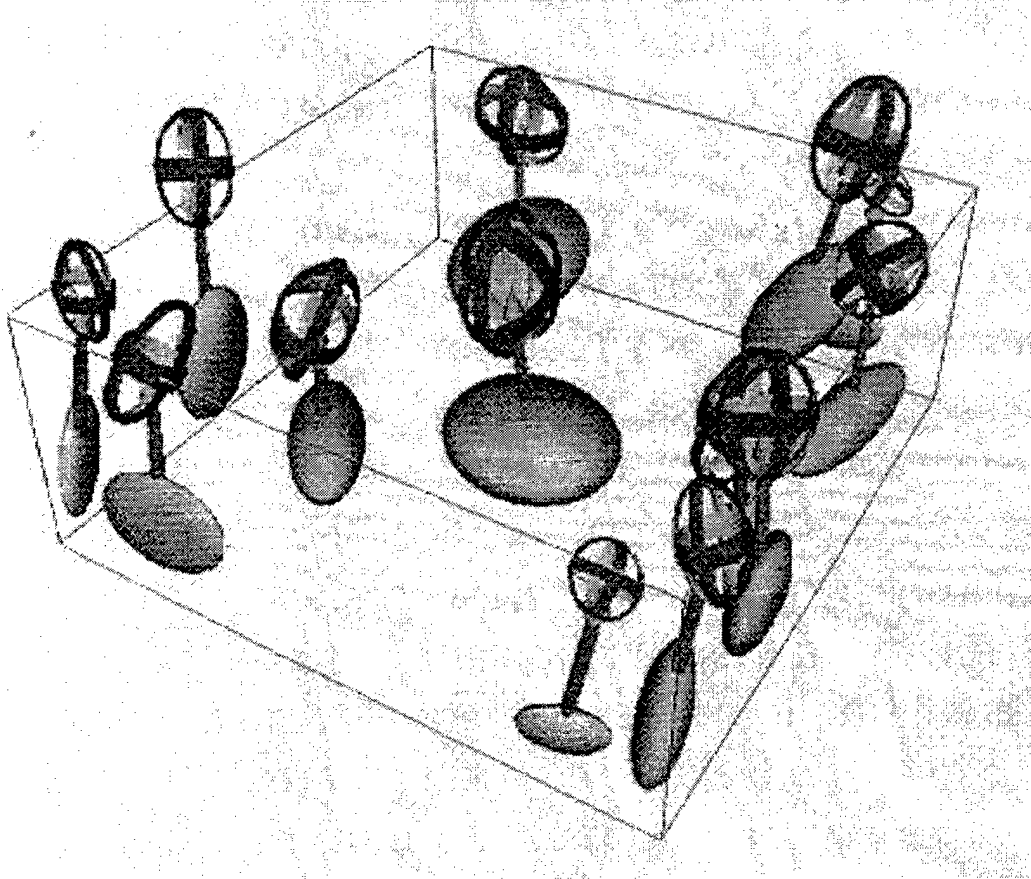

Figure 15 Iconic view of data showing the flow of Nitrogen Dioxide in a chemical reaction (Walsum, 1996)

striped ellipsoids at the end show velocity variance and covariance. While the first method is more intuitive it is an extremely cluttered picture and makes it difficult to see the general flow pattern. The second version contains all of the relevant information with fewer objects. It is simply less intuitive and requires more explanation as to what the icons mean (Walsum, 1996).

The emphasis here is not the rendering. Once again a typical surface renderer is used on the icon models. The two very different views of the same data reveal how different the visualization can look from something real and still provide a great deal of information. Until further research and experience develop a sense of what kinds of icons

do and do not work, lots of trial and error will be required. Iconization has the advantage of presenting a lot data but rendering less which can again increase navigation.

i. Texturing Transparent Shapes

The fact that illusion is still a thriving business in spite of photography is evidence that the illustrative can often be more illuminating while photorealism can hide relevant data. The data set considered is from radiation therapy of tumors. Two isosurfaces are shown, the outer transparent layer represents the radiation dosage while the inner layer is the tumor. Figure 16 compares the transparent rendering versus a solid rendering and finally a semi-opaque texture map which is designed to show the relative closeness of the outer shell to the inner tumor (Interrante, 1997).

Using texture mapping here is a little like iconization. It is considered here because it has the potential to add several transparent layers and still reveal the shape of each of the individual layers.

j. Visualizing Position Error Data

At first, the volume rendering methods appear ideal for viewing the position error data and answering the question, "what is the relative error throughout the volume?".

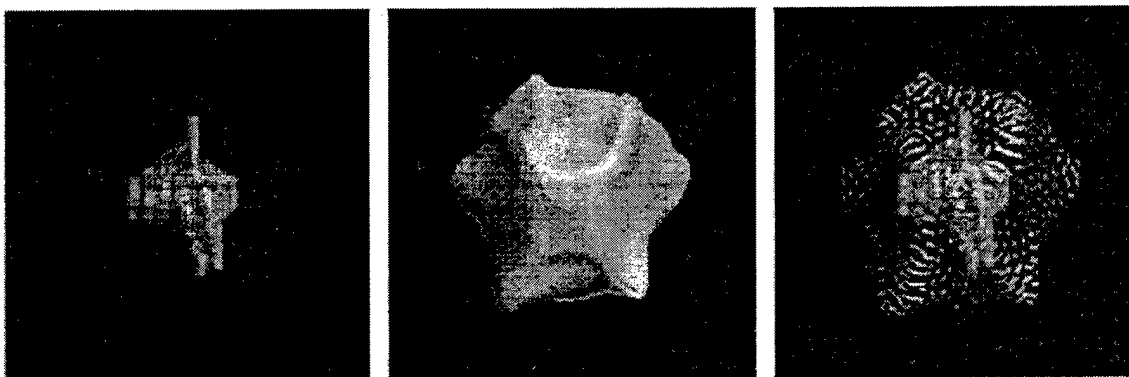

Figure 16 Three views of a tumor and the effective volume of the radiation therapy designed to destroy it (Interrante, 1997)

However, almost all of the volume renderings shown have some recognizable shape. Until the initial renderings the shape of the error data is not known. Having a known shape helps bring what is a very fuzzy looking picture into view. A known shape is not relevant to the data set. The volume renders also appeared to be much more computationally expensive compared to surface rendering so despite some of the improvements, some interactivity would be lost for individuals on the network with lower end systems. Had the volume renders provided more substantial cause for use, the decision to use VRML which has no provision for volume rendering would have been reconsidered.

Several versions of surface models were considered. A solid object does not apply but cutting away portions and texturing the exposed area based on the data had possibilities. Making the right cut would be difficult. It would require a lot of work by the user exploring through the data to fully comprehend an answer. Automatic animation of the cutaways might help but would still not quite achieve the desired results. Doing the cutaways would demand interactivity which goes beyond navigating in 3D through the data set. Each change in the cutaway would require the calculation of a new texture to map on to the surface before the rendering could be done.

The next step would be drawing surfaces that represent the boundary of each level of accuracy which is related to the feature extraction methods previously mentioned. Two methods could be used. One would allow flipping between each level and only drawing those surfaces. Again drawing as solids may hide significant data of interest. Using transparency is an option but only for a couple of layers. Adding more layers would again obscure data.

The only remaining method is some form of iconization of the data. Iconization could be done by grouping data or by providing an icon for every data point. A natural way to group the data was not apparent other than what had already been described

for surface or volume extraction. Iconization of each data point with consideration for avoiding the cluttered unreadable look of the previous example is the logical choice.

The first icon attempt used spheres. Both the size of the sphere and the shading from black to white were related inversely to the error (large black = small error, small white = large error). While using two methods seems redundant it was necessary so that a large sphere at a distance which would appear small would not be mistaken for a small inaccurate data point. The visualization was very effective in giving a sense of solid for the accurate volume spaces and openness in the inaccurate areas. Because this system was entirely in grayscale, it could be easily printed and reproduced without loss of information. Unfortunately rendering 1331 spheres proved too much for any of the VRML viewers, even on relatively high end work stations. It was determined that any polygon based surfaces would be too difficult to render at interactive speeds.

The final visualization devised takes advantage of the speed with which VRML can render points and lines. Large numbers of points well beyond what will probably be required can be rendered on older slower systems without loss of interactivity. Every point on the grid would be assigned a color based on the accuracy. Because too fine a color scale blurred the data too much, it was decided to divide up the data by error ranges and assign each range a color. Because the grid used was evenly spaced, it was still difficult to distinguish the different volumes of accuracy. Adding points around each point to simulate a volume object was attempted. More points were added around the low error data points. This made the accurate areas stand out as dense volumes and the low accuracy volumes as very sparse. The final visualization used five different point based colored icons. This allowed for the desired viewing of the entire volume while maintaining interactivity. Most importantly it revealed the relative error as it changed through the volume.

3. Rendering the visualization

As discussed above, the method of rendering the visualization is entirely dependent on the other considerations described. Had VRML truly placed a limit on the ability to properly render a usable visualization, it would have been dropped for another solution which was not as capable in the areas of multiple platforms and network delivery.

V. IMPLEMENTATION

The implementation is divided into two separate applications. The first application accepts the definition of a volume space, the positions of the receivers, and a time error and outputs a grid with the greatest of the position errors. The second application converts the receiver position data and the grid of position error data into a VRML file which can be viewed in a VRML browser.

A. PROGRAMMING THE MODEL AND SIMULATION

Programming the model and simulation is very simple and straight forward. Only two functions are required. The main function controls the simulation including user inputs, looping through the volume grid, calculating the time errors, calling the `calculateDistanceError` function, and outputting the data to a file. The `calculateDistanceError` function represents the model of the TDOA solution in the Appendix. It accepts three TDOA's, calculates the position and compares it to the actual position and returns a greatest position error.

The main function first requests a minimum x, y and z value and a maximum x, y and z value. The function also asks for an interval value. These seven values define the equally spaced volume grid over which the data will be created. Next, the x, y, and z position of each of the four receivers must be entered. The positions of the receivers are not limited by the target volume. They can be located either inside or outside the volume. The last piece of required data is the time error. There is no particular limit to what time error can be used. Because this system is intended to analyze a tracking system for VE, time errors that represent the millimeter scale of position error are appropriate.

Once all of the data is entered, three nested loops step through x, y, and z of the grid. For each grid position, equations 4, 5 and 6 are used to calculate the three actual TDOA's

between the pairs of receivers. Six new TDOA's are calculated by adding and subtracting the time error from the actual TDOA. The calculateDistanceError function is called once for each combination of the six error TDOA's. The grid position and the largest time error is then output to a data file.

The calculateDistanceError function is just a C version of the equations in the Appendix. While there are really only three equations, one each for x, y, and z, the equations are much too unwieldy to be written out as single equations. Multiple substitutions have been used to make the equations readable. The reuse of many of the substitutions also cuts down on the total number of calculations required since calculations are not repeated. Once the position is calculated, it is compared to the grid position and a maximum error is returned to the main function.

B. PROGRAMMING THE VISUALIZATION

Programming the visualization has two parts. First the VRML format is developed to create the visualization. This will only be a description of the VRML format used and not how VRML works in general. The second part is the C application which reads the data file created in the last application and creates the VRML files.

A VRML file is primarily a list of shapes called nodes which define the objects to be viewed. Some specialized nodes provide for views and for user interaction. VRML allows for objects to be located in separate files. The main file can open and load the objects located in other files. This visualization uses eight separate files.

The main file is opened by the VRML browser to view the entire visualization. First several Viewpoint nodes are defined to provide several preset views for easy navigation. A NavigationInfo node sets the browser to EXAMINE to allow rotation, zooming and panning of the visualization. An IndexedLineSet creates a reference plane grid. The rest of the file uses Inline nodes to load the other portions of the visualization. The main file never changes

for different data sets. It can be easily modified with a text editor if a user wants to include more information or change preset views.

The first file loaded by main is the receivers. The receivers file is created by the application to include the position of each of the receivers in Transform nodes which change the location of a shape. It also uses an Inline node for each Transform to load the shape used to represent the receiver. This makes the shape of each receiver the same and allows for easy modification of the shape by editing the receiver shape file.

The last five files are essentially the same except for the color used. Each of the files represent one of the bins used to divide up the grid based on some scale of accuracy. The files use a PointSet node which contain all of the points from the grid which fit into that accuracy bin. Extra points are also added as noted above to create the iconization. Because of the loose format of the PointSet node, the visualization could use any random set of points and is not limited to the grid which is defined in the data creation application.

The data to VRML application written in C is again very straight forward. First the data file is opened. The receivers' positions are read from the file and the VRML receivers file is created with the receivers' positions. Then five separate files are opened, one for each of the five colored accuracy bins. Each data point is read from the data file with its position error. The data point is sorted into the appropriate file based on the error along with added points to create the iconization. All of the files are then closed and the data is ready to be visualized in a VRML browser.

VI. RESULTS OF ANALYSIS

The simulation was run with the following test data:

Grid Minimum $(x,y,z) = (-3.0m, 0.0m, -3.0m)$,

Grid Maximum $(x,y,z) = (3.0m, 4.0m, 3.0m)$, Grid Interval = 0.5m,

RS1 $(x_1, y_1, z_1) = (-3.0m, 0.0m, -3.0m)$, RS2 $(x_2, y_2, z_2) = (3.0m, 4.0m, -3.0m)$,

RS3 $(x_3, y_3, z_3) = (3.0m, 0.0m, 3.0m)$, RS4 $(x_4, y_4, z_4) = (-3.0m, 4.0m, 3.0m)$,

Time error = $1.667 * 10^{-12}$ sec (which represents a minimum of a 0.5mm position error).

The data was then turned into the VRML files with the bins set at: Yellow # 1.0mm,

1.0mm < YellowGreen # 1.1mm, 1.1mm < GreenBlue # 1.2mm,

1.2mm < BlueGreen # 1.3mm, 1.3mm < Blue. Two views of the results are shown in Figure 17.

At first Figure 17(a) was a surprise because of the asymmetric results despite the symmetric arrangement of the receivers. The TDOA equations have two sets of inputs though. One set is the receivers' positions which are in a symmetrical arrangement. The other set of inputs is the TDOA measurements. The three measurements used, between RS1 and RS2, RS2 and RS3, and RS3 and RS4 are arranged on three sides of the target volume and are not symmetrical except in one direction. Figure 17(b) confirms this analysis because it is a view from the one side that has symmetry in the arrangement of the TDOA's and it does show symmetry in the error.

This knowledge obtained by viewing the 3D error has obvious benefits in determining how to arrange the receivers to the best use. An even more creative use of the knowledge is a change in how the tracking system operates. Without changing the locations of any of the receivers it is possible to get several different error distributions simply by

changing which pairs of receivers the TDOA's are measured across. While manually changing this would save moving the receivers, an electronic method of selecting pairs has even greater potential. The target volume could be divided into regions determined by which set of TDOA's provides the most accurate data. When the transmitter moves from one region to the next, the set of TDOA's could be automatically switched to provide the best data.

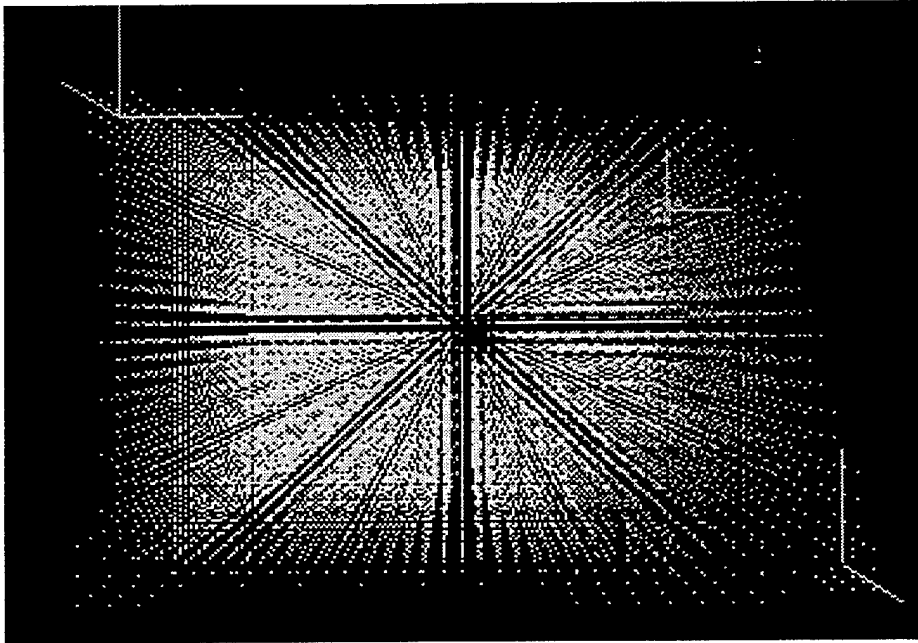

(a)

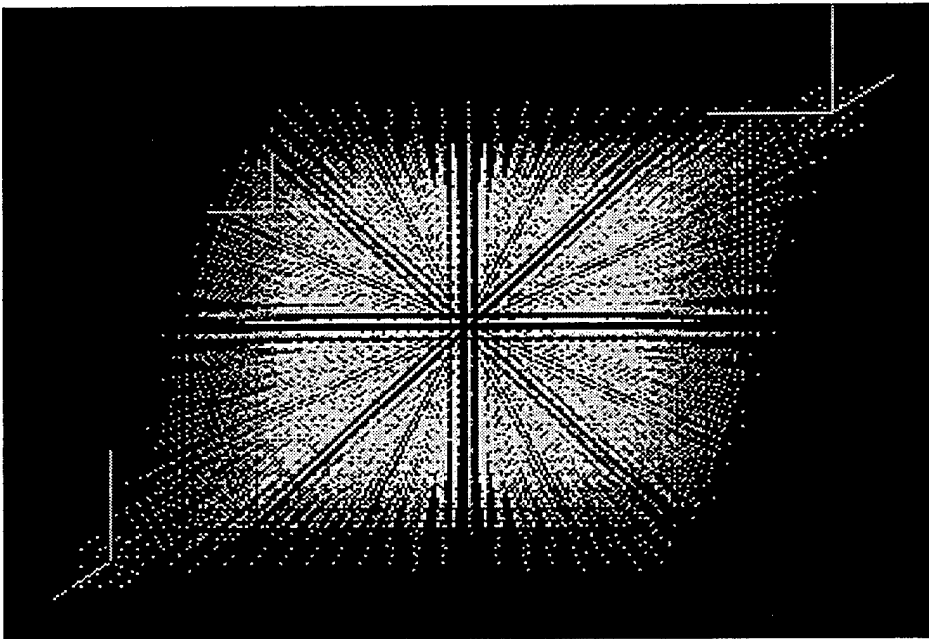

(b)

Figure 17 Screen shots of the RF error data visualization. (a) View from beside receivers RS4 and RS3 showing asymmetry. (b) View from beside receivers RS3 and RS2 showing symmetry

VII. CONCLUSIONS AND RECOMMENDATIONS

The results of the RF tracking system analysis in the last chapter demonstrate the potential of having effective evaluation tools for all of the VE tracking technologies. The design of the analysis system shows how effective the methodology can be toward taking the huge project of creating the tools and dividing it up into manageable parts which immediately result in independently useful analysis tools.

The ultimate goal is still to gather together a complete system for analysis of all of the tracking technologies and a means of relevant comparison. Future work should continue in both the modeling and simulation arena as well as the development of appropriate methods of visualization.

One of the most difficult obstacles to overcome is the holy grail of reusable parts. In computer programming, object oriented programming has promised write code once and reuse over and over again. However, it has been estimated that code must be utilized at least four times before it becomes cost effective in both time and other resources. In other words, the cost of developing the reusable code and reutilizing it three more times is the same as independently developing four similar projects. This same high cost applies to developing models and simulations that contain reusable portions that can be applied to other similar technologies. Because the methodology emphasizes keeping an eye toward the big picture while focusing on a particular project, it should encourage the development of all of the small reusable parts it will take to create a completed tool system.

APPENDIX. SOLUTION TO TDOA

The given positions of the receivers:

$$(x_1, y_1, z_1), (x_2, y_2, z_2), (x_3, y_3, z_3), (x_4, y_4, z_4)$$

The time difference of arrival measurements:

$$t_1 - t_2, t_2 - t_3, t_3 - t_4$$

Find the position of the transmitter:

$$(x, y, z)$$

The equations which relate the positions of the receivers and the transmitter to the time difference of arrival:

$$\frac{\sqrt{(x-x_1)^2 + (y-y_1)^2 + (z-z_1)^2} - \sqrt{(x-x_2)^2 + (y-y_2)^2 + (z-z_2)^2}}{v} = t_1 - t_2 \quad (1)$$

$$\frac{\sqrt{(x-x_2)^2 + (y-y_2)^2 + (z-z_2)^2} - \sqrt{(x-x_3)^2 + (y-y_3)^2 + (z-z_3)^2}}{v} = t_2 - t_3 \quad (2)$$

$$\frac{\sqrt{(x-x_3)^2 + (y-y_3)^2 + (z-z_3)^2} - \sqrt{(x-x_4)^2 + (y-y_4)^2 + (z-z_4)^2}}{v} = t_3 - t_4 \quad (3)$$

Rearrange equation 1:

$$\sqrt{(x-x_1)^2 + (y-y_1)^2 + (z-z_1)^2} = \sqrt{(x-x_2)^2 + (y-y_2)^2 + (z-z_2)^2} + v(t_1 - t_2) \quad (4)$$

Square equation 4:

$$(x-x_1)^2 + (y-y_1)^2 + (z-z_1)^2 = (x-x_2)^2 + (y-y_2)^2 + (z-z_2)^2 + 2v(t_1 - t_2)\sqrt{(x-x_2)^2 + (y-y_2)^2 + (z-z_2)^2} + v^2(t_1 - t_2)^2$$

Expand:

$$x^2 - 2xx_1 + x_1^2 + y^2 - 2yy_1 + y_1^2 + z^2 - 2zz_1 + z_1^2 = x^2 - 2xx_2 + x_2^2 + y^2 - 2yy_2 + y_2^2 + z^2 - 2zz_2 + z_2^2 + 2v(t_1 - t_2)\sqrt{(x-x_2)^2 + (y-y_2)^2 + (z-z_2)^2} + v^2(t_1 - t_2)^2$$

Combine like terms and divide by $v(t_1 - t_2)$:

$$\frac{x_1^2 + y_1^2 + z_1^2 - 2xx_1 - 2yy_1 - 2zz_1}{v(t_1 - t_2)} = \frac{x_2^2 + y_2^2 + z_2^2 - 2xx_2 - 2yy_2 - 2zz_2}{v(t_1 - t_2)} + 2\sqrt{(x-x_2)^2 + (y-y_2)^2 + (z-z_2)^2} + v(t_1 - t_2) \quad (5)$$

Negate equation 2 and rearrange like equation 4:

$$\sqrt{(x-x_3)^2 + (y-y_3)^2 + (z-z_3)^2} = \sqrt{(x-x_2)^2 + (y-y_2)^2 + (z-z_2)^2} + v(t_3 - t_2)$$

Square:

$$(x-x_3)^2 + (y-y_3)^2 + (z-z_3)^2 = (x-x_2)^2 + (y-y_2)^2 + (z-z_2)^2 + 2v(t_3 - t_2)\sqrt{(x-x_2)^2 + (y-y_2)^2 + (z-z_2)^2} + v^2(t_3 - t_2)^2$$

Expand:

$$x^2 - 2xx_3 + x_3^2 + y^2 - 2yy_3 + y_3^2 + z^2 - 2zz_3 + z_3^2 = x^2 - 2xx_2 + x_2^2 + y^2 - 2yy_2 + y_2^2 + z^2 - 2zz_2 + z_2^2 + 2v(t_3 - t_2)\sqrt{(x-x_2)^2 + (y-y_2)^2 + (z-z_2)^2} + v^2(t_3 - t_2)^2$$

Combine like terms and divide by $v(t_3 - t_2)$:

$$\frac{x_3^2 + y_3^2 + z_3^2 - 2xx_3 - 2yy_3 - 2zz_3}{v(t_3 - t_2)} = \frac{x_2^2 + y_2^2 + z_2^2 - 2xx_2 - 2yy_2 - 2zz_2}{v(t_3 - t_2)} + 2\sqrt{(x-x_2)^2 + (y-y_2)^2 + (z-z_2)^2} + v(t_3 - t_2) \quad (6)$$

Subtract equation 5 from equation 6:

$$\frac{x_3^2 + y_3^2 + z_3^2 - 2xx_3 - 2yy_3 - 2zz_3}{v(t_3 - t_2)} - \frac{x_1^2 + y_1^2 + z_1^2 - 2xx_1 - 2yy_1 - 2zz_1}{v(t_1 - t_2)} = \frac{x_2^2 + y_2^2 + z_2^2 - 2xx_2 - 2yy_2 - 2zz_2}{v(t_3 - t_2)} - \frac{x_2^2 + y_2^2 + z_2^2 - 2xx_2 - 2yy_2 - 2zz_2}{v(t_1 - t_2)} + v(t_3 - t_2) - v(t_1 - t_2)$$

Rearrange in the form $a_{11}x + a_{12}y + a_{13}z = b_1$: (7)

$$x \left(\frac{x_3 - x_2}{v(t_3 - t_2)} - \frac{x_1 - x_2}{v(t_1 - t_2)} \right) + y \left(\frac{y_3 - y_2}{v(t_3 - t_2)} - \frac{y_1 - y_2}{v(t_1 - t_2)} \right) + z \left(\frac{z_3 - z_2}{v(t_3 - t_2)} - \frac{z_1 - z_2}{v(t_1 - t_2)} \right) = \frac{(x_3^2 + y_3^2 + z_3^2) - (x_2^2 + y_2^2 + z_2^2)}{2v(t_3 - t_2)} - \frac{(x_1^2 + y_1^2 + z_1^2) - (x_2^2 + y_2^2 + z_2^2)}{2v(t_1 - t_2)} + \frac{v(t_1 - t_2) - v(t_3 - t_2)}{2}$$

In equation 7:

$$a_{11} = \left(\frac{x_3 - x_2}{v(t_3 - t_2)} - \frac{x_1 - x_2}{v(t_1 - t_2)} \right)$$

$$a_{12} = \left(\frac{y_3 - y_2}{v(t_3 - t_2)} - \frac{y_1 - y_2}{v(t_1 - t_2)} \right)$$

$$a_{13} = \left(\frac{z_3 - z_2}{v(t_3 - t_2)} - \frac{z_1 - z_2}{v(t_1 - t_2)} \right)$$

$$b_1 = \frac{(x_3^2 + y_3^2 + z_3^2) - (x_2^2 + y_2^2 + z_2^2)}{2v(t_3 - t_2)} - \frac{(x_1^2 + y_1^2 + z_1^2) - (x_2^2 + y_2^2 + z_2^2)}{2v(t_1 - t_2)} + \frac{v(t_1 - t_2) - v(t_3 - t_2)}{2}$$

Repeat the above steps for equations 2 and 3.

Rearrange equation 2:

$$\sqrt{(x - x_2)^2 + (y - y_2)^2 + (z - z_2)^2} = \sqrt{(x - x_3)^2 + (y - y_3)^2 + (z - z_3)^2} + v(t_2 - t_3)$$

Square:

$$(x - x_2)^2 + (y - y_2)^2 + (z - z_2)^2 = (x - x_3)^2 + (y - y_3)^2 + (z - z_3)^2 + 2v(t_2 - t_3)\sqrt{(x - x_3)^2 + (y - y_3)^2 + (z - z_3)^2} + v^2(t_2 - t_3)^2$$

Expand:

$$x^2 - 2xx_2 + x_2^2 + y^2 - 2yy_2 + y_2^2 + z^2 - 2zz_2 + z_2^2 = x^2 - 2xx_3 + x_3^2 + y^2 - 2yy_3 + y_3^2 + z^2 - 2zz_3 + z_3^2 + 2v(t_2 - t_3)\sqrt{(x - x_3)^2 + (y - y_3)^2 + (z - z_3)^2} + v^2(t_2 - t_3)^2$$

Combine like terms and divide by $v(t_2 - t_3)$:

$$\frac{x_2^2 + y_2^2 + z_2^2 - 2xx_2 - 2yy_2 - 2zz_2}{v(t_2 - t_3)} = \frac{x_3^2 + y_3^2 + z_3^2 - 2xx_3 - 2yy_3 - 2zz_3}{v(t_2 - t_3)} + 2\sqrt{(x-x_3)^2 + (y-y_3)^2 + (z-z_3)^2} + v(t_2 - t_3) \quad (8)$$

Negate equation 3 and rearrange like equation 4:

$$\sqrt{(x-x_4)^2 + (y-y_4)^2 + (z-z_4)^2} = \sqrt{(x-x_3)^2 + (y-y_3)^2 + (z-z_3)^2} + v(t_4 - t_3)$$

Square:

$$(x-x_4)^2 + (y-y_4)^2 + (z-z_4)^2 = (x-x_3)^2 + (y-y_3)^2 + (z-z_3)^2 + 2v(t_4 - t_3)\sqrt{(x-x_3)^2 + (y-y_3)^2 + (z-z_3)^2} + v^2(t_4 - t_3)^2$$

Expand:

$$x^2 - 2xx_4 + x_4^2 + y^2 - 2yy_4 + y_4^2 + z^2 - 2zz_4 + z_4^2 = x^2 - 2xx_3 + x_3^2 + y^2 - 2yy_3 + y_3^2 + z^2 - 2zz_3 + z_3^2 + 2v(t_4 - t_3)\sqrt{(x-x_3)^2 + (y-y_3)^2 + (z-z_3)^2} + v^2(t_4 - t_3)^2$$

Combine like terms and divide by $v(t_4 - t_3)$:

$$\frac{x_4^2 + y_4^2 + z_4^2 - 2xx_4 - 2yy_4 - 2zz_4}{v(t_4 - t_3)} = \frac{x_3^2 + y_3^2 + z_3^2 - 2xx_3 - 2yy_3 - 2zz_3}{v(t_4 - t_3)} + 2\sqrt{(x-x_3)^2 + (y-y_3)^2 + (z-z_3)^2} + v(t_4 - t_3) \quad (9)$$

Subtract equation 8 from equation 9:

$$\frac{x_4^2 + y_4^2 + z_4^2 - 2xx_4 - 2yy_4 - 2zz_4}{v(t_4 - t_3)} - \frac{x_2^2 + y_2^2 + z_2^2 - 2xx_2 - 2yy_2 - 2zz_2}{v(t_2 - t_3)} = \frac{x_3^2 + y_3^2 + z_3^2 - 2xx_3 - 2yy_3 - 2zz_3}{v(t_4 - t_3)} - \frac{x_3^2 + y_3^2 + z_3^2 - 2xx_3 - 2yy_3 - 2zz_3}{v(t_2 - t_3)} + v(t_4 - t_3) - v(t_2 - t_3)$$

Rearrange in the form $a_{21}x + a_{22}y + a_{23}z = b_2$: (10)

$$x \left(\frac{x_4 - x_3}{v(t_4 - t_3)} - \frac{x_2 - x_3}{v(t_2 - t_3)} \right) + y \left(\frac{y_4 - y_3}{v(t_4 - t_3)} - \frac{y_2 - y_3}{v(t_2 - t_3)} \right) + z \left(\frac{z_4 - z_3}{v(t_4 - t_3)} - \frac{z_2 - z_3}{v(t_2 - t_3)} \right) = \frac{(x_4^2 + y_4^2 + z_4^2) - (x_3^2 + y_3^2 + z_3^2)}{2v(t_4 - t_3)} - \frac{(x_2^2 + y_2^2 + z_2^2) - (x_3^2 + y_3^2 + z_3^2)}{2v(t_2 - t_3)} + \frac{v(t_2 - t_3) - v(t_4 - t_3)}{2}$$

In equation 10:

$$a_{21} = \left(\frac{x_4 - x_3}{v(t_4 - t_3)} - \frac{x_2 - x_3}{v(t_2 - t_3)} \right)$$

$$a_{22} = \left(\frac{y_4 - y_3}{v(t_4 - t_3)} - \frac{y_2 - y_3}{v(t_2 - t_3)} \right)$$

$$a_{23} = \left(\frac{z_4 - z_3}{v(t_4 - t_3)} - \frac{z_3 - z_2}{v(t_3 - t_2)} \right)$$

$$b_2 = \frac{(x_4^2 + y_4^2 + z_4^2) - (x_3^2 + y_3^2 + z_3^2)}{2v(t_4 - t_3)} - \frac{(x_2^2 + y_2^2 + z_2^2) - (x_3^2 + y_3^2 + z_3^2)}{2v(t_2 - t_3)} + \frac{v(t_2 - t_3) - v(t_4 - t_3)}{2}$$

Using equations 7 and 10 solve for y and z in terms of x.

Multiply equation 7 by a_{23} :

$$a_{23} a_{11} x + a_{23} a_{12} y + a_{23} a_{13} z = a_{23} b_1$$

Multiply equation 10 by a_{13} :

$$a_{13} a_{21} x + a_{13} a_{22} y + a_{13} a_{23} z = a_{13} b_2$$

Subtract the two new equations:

$$(a_{23} a_{11} - a_{13} a_{21})x + (a_{23} a_{12} - a_{13} a_{22})y = a_{23} b_1 - a_{13} b_2$$

Divide by $a_{13} a_{23}$:

$$\left(\frac{a_{11}}{a_{13}} - \frac{a_{21}}{a_{23}} \right) x + \left(\frac{a_{12}}{a_{13}} - \frac{a_{22}}{a_{23}} \right) y = \frac{b_1}{a_{13}} - \frac{b_2}{a_{23}}$$

Solve for y:

$$y = -\frac{\left(\frac{a_{11}}{a_{13}} - \frac{a_{21}}{a_{23}}\right)}{\left(\frac{a_{12}}{a_{13}} - \frac{a_{22}}{a_{23}}\right)}x + \frac{\left(\frac{b_1}{a_{13}} - \frac{b_2}{a_{23}}\right)}{\left(\frac{a_{12}}{a_{13}} - \frac{a_{22}}{a_{23}}\right)} \quad (11)$$

Multiply equation 7 by a_{22} :

$$a_{22}a_{11}x + a_{22}a_{12}y + a_{22}a_{13}z = a_{22}b_1$$

Multiply equation 10 by a_{12} :

$$a_{12}a_{21}x + a_{12}a_{22}y + a_{12}a_{23}z = a_{12}b_2$$

Subtract the two new equations:

$$(a_{22}a_{11} - a_{12}a_{21})x + (a_{22}a_{13} - a_{12}a_{23})z = a_{22}b_1 - a_{12}b_2$$

Divide by $a_{12}a_{22}$:

$$\left(\frac{a_{11}}{a_{12}} - \frac{a_{21}}{a_{22}}\right)x + \left(\frac{a_{13}}{a_{12}} - \frac{a_{23}}{a_{22}}\right)z = \frac{b_1}{a_{12}} - \frac{b_2}{a_{22}}$$

Solve for z:

$$z = -\frac{\left(\frac{a_{11}}{a_{12}} - \frac{a_{21}}{a_{22}}\right)}{\left(\frac{a_{13}}{a_{12}} - \frac{a_{23}}{a_{22}}\right)}x + \frac{\left(\frac{b_1}{a_{12}} - \frac{b_2}{a_{22}}\right)}{\left(\frac{a_{13}}{a_{12}} - \frac{a_{23}}{a_{22}}\right)} \quad (12)$$

Define:

$$a = -\frac{\left(\frac{a_{11}}{a_{13}} - \frac{a_{21}}{a_{23}}\right)}{\left(\frac{a_{12}}{a_{13}} - \frac{a_{22}}{a_{23}}\right)}, \quad b = \frac{\left(\frac{b_1}{a_{13}} - \frac{b_2}{a_{23}}\right)}{\left(\frac{a_{12}}{a_{13}} - \frac{a_{22}}{a_{23}}\right)}, \quad c = -\frac{\left(\frac{a_{11}}{a_{12}} - \frac{a_{21}}{a_{22}}\right)}{\left(\frac{a_{13}}{a_{12}} - \frac{a_{23}}{a_{22}}\right)}, \quad d = \frac{\left(\frac{b_1}{a_{12}} - \frac{b_2}{a_{22}}\right)}{\left(\frac{a_{13}}{a_{12}} - \frac{a_{23}}{a_{22}}\right)}$$

Substitute in equations 11 and 12:

$$y = ax + b, \quad z = cx + d$$

Substitute for y and z in equation 4:

$$\sqrt{(x-x_1)^2 + (ax+b-y_1)^2 + (cx+d-z_1)^2} = \sqrt{(x-x_2)^2 + (ax+b-y_2)^2 + (cx+d-z_2)^2} + v(t_1-t_2)$$

Square and expand terms:

$$\begin{aligned} & x^2 - 2xx_1 + x_1^2 + (ax)^2 + 2ax(b-y_1) + (b-y_1)^2 + (cx)^2 + 2cx(d-z_1) + (d-z_1)^2 \\ = & x^2 - 2xx_2 + x_2^2 + (ax)^2 + 2ax(b-y_2) + (b-y_2)^2 + (cx)^2 + 2cx(d-z_2) + (d-z_2)^2 \\ & + 2v(t_1-t_2)\sqrt{(x-x_2)^2 + (ax+b-y_2)^2 + (cx+d-z_2)^2} + v^2(t_1-t_2)^2 \end{aligned}$$

Isolate square root and combine like terms:

$$\begin{aligned} & x \left(\frac{-x_1 + a(b-y_1) + c(d-z_1) + x_2 - a(b-y_2) - c(d-z_2)}{v(t_1-t_2)} \right) \\ + & \frac{x_1^2 + (b-y_1)^2 + (d-z_1)^2 - x_2^2 - (b-y_2)^2 - (d-z_2)^2 - v^2(t_1-t_2)^2}{2v(t_1-t_2)} \quad (13) \\ = & \sqrt{(x-x_2)^2 + (ax+b-y_2)^2 + (cx+d-z_2)^2} \end{aligned}$$

Define:

$$\begin{aligned} \eta_1 &= x_1 - a(b-y_1) - c(d-z_1), & \eta_2 &= x_2 - a(b-y_2) - c(d-z_2) \\ \xi_1 &= x_1^2 + (b-y_1)^2 + (d-z_1)^2, & \xi_2 &= x_2^2 + (b-y_2)^2 + (d-z_2)^2 \end{aligned}$$

Substitute the above in equation 13 and square:

$$\begin{aligned} & x^2 \left(\frac{\eta_2 - \eta_1}{v(t_1-t_2)} \right)^2 + 2x \left(\frac{\eta_2 - \eta_1}{v(t_1-t_2)} \right) \left(\frac{\xi_1 - \xi_2 - v^2(t_1-t_2)^2}{2v(t_1-t_2)} \right) + \left(\frac{\xi_1 - \xi_2 - v^2(t_1-t_2)^2}{2v(t_1-t_2)} \right)^2 \\ & = (x-x_2)^2 + (ax+b-y_2)^2 + (cx+d-z_2)^2 \end{aligned}$$

Expand terms on right side and make substitutions:

$$\begin{aligned} & x^2 \left(\frac{\eta_2 - \eta_1}{v(t_1-t_2)} \right)^2 + 2x \left(\frac{\eta_2 - \eta_1}{v(t_1-t_2)} \right) \left(\frac{\xi_1 - \xi_2 - v^2(t_1-t_2)^2}{2v(t_1-t_2)} \right) + \left(\frac{\xi_1 - \xi_2 - v^2(t_1-t_2)^2}{2v(t_1-t_2)} \right)^2 \\ & = x^2(1+a^2+c^2) - 2x\eta_2 + \xi_2 \end{aligned}$$

Define:

$$f = \frac{\eta_2 - \eta_1}{v(t_1 - t_2)}, \quad g = \frac{\xi_1 - \xi_2 - v^2(t_1 - t_2)^2}{2v(t_1 - t_2)}$$

Combine like terms and make substitutions:

$$x^2(1 + a^2 + c^2 - f^2) - 2x(\eta_2 + fg) + \xi_2 - g^2 = 0$$

Define:

$$h_1 = 1 + a^2 + c^2 - f^2, \quad h_2 = -2(\eta_2 + fg), \quad h_3 = \xi_2 - g^2$$

Substitute:

$$h_1 x^2 + h_2 x + h_3 = 0$$

Solve the quadratic for x:

$$x = \frac{-h_2 \pm \sqrt{h_2^2 - 4h_1 h_3}}{2h_1}$$

LIST OF REFERENCES

- Advanced Position Systems, INC., "An RF Head-Tracker", *Defense Small Business Innovation Research Program Reports*, Contract Number N00014-96-C-6206, 1996.
- Brady, M. L., Jung, K. K., Nguyen, H. T., and Nguyen, T. PQ, "Interactive Volume Navigation", *IEEE Transactions on Visualization and Computer Graphics*, vol. 4, no. 3, pp. 243-256, IEEE Computer Society, 1998.
- Cignoni, P., Montani, C. Puppo, E., and Scopigno, R., "Multiresolution Representation and Visualization of Volume Data", *IEEE Transactions on Visualization and Computer Graphics*, vol. 3, no. 4, pp. 352-369, IEEE Computer Society, 1997.
- Donnelly, D., "CIP's Ninth Annual Software Contest: The Winners", *Computers in Physics*, vol. 12, no. 6, pp. 556-564, American Institute of Physics, 1998.
- Emura, S. and Tachi, S., "Multisensor Integrated Prediction for Virtual Reality", *PRESENCE*, vol. 7, no. 4, pp. 410-422, The Massachusetts Institute of Technology, 1998.
- Fujishiro, I., Maeda, Y., Sato, H., and Takeshima, Y., "Volumetric Data Exploration Using Interval Volume", *IEEE Transactions on Visualization and Computer Graphics*, vol. 2, no. 2, pp. 144-154, IEEE Computer Society, 1996.
- Interrante, V., Fuchs, H., and Pizer, S. M., "Conveying the 3D Shape of Smoothly Curving Transparent Surfaces via Texture", *IEEE Transactions on Visualization and Computer Graphics*, vol. 3, no. 2, pp. 98-117, IEEE Computer Society, 1997.
- Meyer, K., Applewhite, H. L., and Biocca, "A Survey of Position trackers", *PRESENCE*, vol. 1, no. 2, pp. 173-200, The Massachusetts Institute of Technology, 1992.
- Nielson, G. M., "Challenges in Visualization Research", *IEEE Transactions on Visualization and Computer Graphics*, vol. 2, no. 2, pp. 97-99, IEEE Computer Society, 1996.
- Silver, D. and Wang, X., "Tracking and Visualizing Turbulent 3D Features", *IEEE Transactions on Visualization and Computer Graphics*, vol. 3, no. 2, pp. 129-141, IEEE Computer Society, 1997.
- Teylingen, R. V., Ribarsky, W., and Mast C., "Virtual Data Visualizer", *IEEE Transactions on Visualization and Computer Graphics*, vol. 3, no. 1, pp. 65-74, IEEE Computer Society, 1997.
- Tufte, E. R., *Envisioning Information*, Graphics Press, 1990.
- Tufte, E. R., *The Visual Display of Quantitative Information*, Graphics Press, 1983.
- Walsum, T., Post, F. H., Silver, D., and Post, F. J., "Feature Extraction and Iconic Visualization", *IEEE Transactions on Visualization and Computer Graphics*, vol. 2, no. 2, pp. 111-119, IEEE Computer Society, 1996.

Williams, P. L., Max, N. L., and Stein, C. M., "A High Accuracy Volume Renderer for Unstructured Data", *IEEE Transactions on Visualization and Computer Graphics*, vol. 4, no. 1, pp. 37-54, IEEE Computer Society, 1998.

Yagel, R., Egert, D. S., Scott, J. N., and Kurzion, Y., "Grouping Volume Renderers for Enhanced Visualization in Computational Fluid Dynamics", *IEEE Transactions on Visualization and Computer Graphics*, vol. 1, no. 2, pp. 117-131, IEEE Computer Society, 1995.

INITIAL DISTRIBUTION LIST

1. Defense Technical Information Center.....2
8725 John J. Kingman Rd., STE 0944
Ft. Belvoir, Virginia 22060-6218
2. Dudley Knox Library.....2
Naval Postgraduate School
411 Dyer Rd.
Monterey, California 93943-5101
3. Professor Dan C. Boger.....1
Naval Postgraduate School (Code CC/BD)
Monterey, California 93943-5101
4. Professor William B. Maier.....1
Naval Postgraduate School (Code PH/MW)
Monterey, California 93943-5101
5. Professor Rudy Darken.....1
Naval Postgraduate School (Code CS/DR)
Monterey, California 93943-5101
6. Professor Xavier Maruyama.....1
Naval Postgraduate School (Code PH/MX)
Monterey, California 93943-5101
7. Philip E. Campbell.....2
590 Sandy Creed Rd.
Fayetteville, Georgia 30214