

**MONTE CARLO SIMULATION FOR APPLICATION TO
AEROSPACE VEHICLE STRUCTURES**

August 1990

**By
R. Vaicaitis
Dept. of Civil Engineering & Engineering Mechanics
Columbus University**

Final Report for Period June 25 - July 27, 1990

Approved for Public Release; Distribution Unlimited

DTIC QUALITY INSPECTED

19990518 061

REPORT DOCUMENTATION PAGE

Form Approved
OMB No. 0704-0188

1a. REPORT SECURITY CLASSIFICATION Unclassified		1b. RESTRICTIVE MARKINGS													
2a. SECURITY CLASSIFICATION AUTHORITY		3. DISTRIBUTION / AVAILABILITY OF REPORT Approved for public release; distribution unlimited.													
2b. DECLASSIFICATION DOWNGRADING SCHEDULE															
4. PERFORMING ORGANIZATION REPORT NUMBER(S)		5. MONITORING ORGANIZATION REPORT NUMBER(S)													
6a. NAME OF PERFORMING ORGANIZATION Columbia University	6b. OFFICE SYMBOL (if applicable) WRDC/FIBG	7a. NAME OF MONITORING ORGANIZATION WRDC/FIBRA													
6c. ADDRESS (City, State, and ZIP Code) Dept. of Civil Engr. & Engr. Mechanics New York, NY 10027		7b. ADDRESS (City, State, and ZIP Code) Wright-Patterson AFB OH 45433-6553													
8a. NAME OF FUNDING / SPONSORING ORGANIZATION Structural Dynamics Branch	8b. OFFICE SYMBOL (if applicable) WRDC/FIBG	9. PROCUREMENT INSTRUMENT IDENTIFICATION NUMBER													
8c. ADDRESS (City, State, and ZIP Code) WRDC/FIBG Wright-Patterson AFB, OH 45433		10. SOURCE OF FUNDING NUMBERS <table border="1" style="width: 100%; border-collapse: collapse; margin-top: 5px;"> <thead> <tr> <th style="width: 25%;">PROGRAM ELEMENT NO</th> <th style="width: 25%;">PROJECT NO.</th> <th style="width: 25%;">TASK NO</th> <th style="width: 25%;">WORK UNIT ACCESSION NO.</th> </tr> </thead> <tbody> <tr> <td style="text-align: center;">62201F</td> <td style="text-align: center;">2401</td> <td style="text-align: center;">02</td> <td style="text-align: center;">77</td> </tr> </tbody> </table>		PROGRAM ELEMENT NO	PROJECT NO.	TASK NO	WORK UNIT ACCESSION NO.	62201F	2401	02	77				
PROGRAM ELEMENT NO	PROJECT NO.	TASK NO	WORK UNIT ACCESSION NO.												
62201F	2401	02	77												
11. TITLE (Include Security Classification) Monte Carlo Simulation for Application to Aerospace Vehicle Structures															
12. PERSONAL AUTHOR(S) Kimas Vaicaitis															
13a. TYPE OF REPORT Interim	13b. TIME COVERED FROM <u>June 25</u> TO <u>July 27</u>	14. DATE OF REPORT (Year, Month, Day) 1990 August 8	15. PAGE COUNT												
16. SUPPLEMENTARY NOTATION															
17. COSATI CODES <table border="1" style="width: 100%; border-collapse: collapse; margin-top: 5px;"> <thead> <tr> <th style="width: 33%;">FIELD</th> <th style="width: 33%;">GROUP</th> <th style="width: 33%;">SUB-GROUP</th> </tr> </thead> <tbody> <tr><td> </td><td> </td><td> </td></tr> <tr><td> </td><td> </td><td> </td></tr> <tr><td> </td><td> </td><td> </td></tr> </tbody> </table>		FIELD	GROUP	SUB-GROUP										18. SUBJECT TERMS (Continue on reverse if necessary and identify by block number)	
FIELD	GROUP	SUB-GROUP													
19. ABSTRACT (Continue on reverse if necessary and identify by block number) <p style="text-align: center;">The basic concepts on simulation of multidimensional and multivariate random processes are presented. The time domain Monte Carlo approach for solution of nonlinear dynamic problems is illustrated by an example. A preliminary fatigue life prediction model based on time domain stress response and fatigue data from constant amplitude coupon tests is developed.</p>															
20. DISTRIBUTION / AVAILABILITY OF ABSTRACT <input type="checkbox"/> UNCLASSIFIED/UNLIMITED <input checked="" type="checkbox"/> SAME AS RPT. <input type="checkbox"/> DTIC USERS		21. ABSTRACT SECURITY CLASSIFICATION													
22a. NAME OF RESPONSIBLE INDIVIDUAL	22b. TELEPHONE (Include Area Code)	22c. OFFICE SYMBOL													

MONTE CARLO SIMULATION FOR APPLICATION TO
AEROSPACE VEHICLE STRUCTURES

August 1990

By

R. Vaicaitis

Dept. of Civil Engineering & Engineering Mechanics
Columbus University

Final Report for Period June 25 - July 27, 1990

Approved for Public Release; Distribution Unlimited

FOREWORD

The objective of the program reported herein was to provide the Flight Dynamics Laboratory, Wright-Patterson Air Force Base, Ohio, with a background on Monte Carlo time domain simulation techniques for application to aerospace vehicle structures. Dr. Jon Lee of WRDC/FIBG was the contract monitor.

The work reported was performed for the Aerospace Structures Information and Analysis Center (ASIAC), which is operated for the Flight Dynamics Laboratory, Wright Research and Development Center, Wright-Patterson Air Force Base, Ohio, by Anamet Laboratories, Inc. under Contract No. F33615-87-C-3228. The ASIAC Task Number was 4.2-34.

TABLE OF CONTENTS

	Page
SECTION 1.0 INTRODUCTION.....	1
SECTION 2.0 TECHNICAL DISCUSSION.....	2
2.1 Simulation of Random Input Pressures in Space-Time Domain.....	2
2.2 Simulation of Multivariate Random Process.....	6
2.3 Nonlinear Response of Surface Panels Subject to High Intensity Noise.....	7
2.4 Sonic Fatigue.....	10
REFERENCES.....	12
Figure.....	14

1.0 INTRODUCTION

The prediction of dynamic response and fatigue life of surface protection systems of high speed aircraft is a critical task in the development of modern flight structures. With an increasing use of lightweight materials, such as fiber-reinforced composites, metal-matrix composites, and various high temperature resistant intermetallic compounds on new generation aircraft, orbital and sub-orbital vehicles, there is a need for improved methods for predicting dynamic response and sonic fatigue life. The future high speed supersonic/hypersonic vehicles will be subjected to severe aerodynamic surface environment, intense acoustic loads and temperatures exceeding 3000° F. The structural and various control surfaces are expected to behave in a highly nonlinear fashion with respect to both geometry and materials.

A time-domain Monte Carlo approach could provide the required methodology for the solution of the various nonlinear problems in relation to thermal surface protection systems of high speed aircraft. These types of procedures have been utilized for response and fatigue analysis on a variety of structural components exposed to severe aerodynamic, acoustic and thermal environment [1-10]. To implement the time domain approach for nonlinear problems with random inputs, simulation of random surface pressures in time-space domain are required. A computer code called SIMLOAD, which simulates in time domain a single dimensional and single variate random pressure, has been implemented on a WRDC computer. These simulated time histories are the required input to the nonlinear time domain problem. One of the basic structural components of a thermal surface protection system is a rectangular plate. A nonlinear deflection/stress response solution has been developed in time domain for a rectangular panel. The computer code called PLATE, which solves for nonlinear deflection and nonlinear stress under uniformly distributed random pressures, was also implemented on a WRDC computer.

2.0 TECHNICAL DISCUSSION

A detailed analysis on the simulation of multidimensional/multivariate stationary/Gaussian random processes, solution of nonlinear time domain random problems, and sonic fatigue using time domain approach has been presented to researchers at WRDC, WPAFB. In what follows, a brief summary of these procedures is given.

2.1 Simulation of Random Input Pressures in Space-Time Domain

Consider a stationary, homogeneous and Gaussian random pressure $p(x,y,t)$ acting on the surface of a high speed flight vehicle. The pressure acting normal to the surface varies randomly in time and space along the surface coordinates x and y . The random pressure is characterized by a cross-spectral density function $S_p(\xi,\eta,\omega)$, where $\xi = x_1 - x_2$ and $\eta = y_1 - y_2$ are the spatial separations and ω is frequency. The spectral density of pressure $p(x,y,t)$ can be obtained in wave-number-frequency domain by taking the Fourier transform of $S_p(\xi,\eta,\omega)$ as

$$S_p(k_1, k_2, \omega) = \frac{1}{(2\pi)^2} \int_{-\infty}^{\infty} \int_{-\infty}^{\infty} S_p(\xi, \eta, \omega) e^{-ik_1\xi} e^{-ik_2\eta} d\xi d\eta \quad (1)$$

in which k_1 and k_2 are the wave numbers. The random sample functions of pressure $p(x,y,t)$ with a zero mean can be generated utilizing simulation procedures of stationary-Gaussian random processes and Fast Fourier Transform (FFT) techniques [11,12]. Then, $p(x,y,t)$ can be simulated by the series

$$p(x, y, t) = \text{Re} \left[\sum_{i=0}^{M_1-1} \sum_{j=0}^{M_2-1} \sum_{r=0}^{M_3-1} A_{ijr} e^{i\phi_{ijr}} e^{i(k_1x + k_2y - \omega_r t)} \right] \quad (2)$$

where

$$A_{ijr} = [2S_p(k_{1i}, k_{2j}, \omega_r) \Delta k_1 \Delta k_2 \Delta \omega]^{1/2} \quad (3)$$

ϕ_{ijr} are realized values of independent random phase angles uniformly distributed between 0 and 2π , and Re indicates the real part. The values of the spectra are selected at

$$\begin{aligned} k_{1j} &= k_{1i} + i \Delta k_1 & i &= 1, 2, \dots, N_1 \\ k_{2j} &= k_{2i} + j \Delta k_2 & j &= 1, 2, \dots, N_2 \\ \omega_r &= \omega_i + r \Delta \omega & r &= 1, 2, \dots, N_3 \end{aligned} \quad (4)$$

where the wave number and frequency intervals are

$$\begin{aligned} \Delta k_1 &= (k_{1u} - k_{1l}) / N_1 \\ \Delta k_2 &= (k_{2u} - k_{2l}) / N_2 \\ \Delta \omega &= (\omega_u - \omega_l) / N_3 \end{aligned} \quad (5)$$

in which the subscripts u and l indicate the lower and the upper cut-off values of the wave number and frequency, respectively. The random pressure $p(x, y, t)$ is evaluated at

$$\begin{aligned}
 x &= m\Delta x, & m &= 0, 1, \dots, M_1 - 1 \\
 y &= n\Delta y, & n &= 0, 1, \dots, M_2 - 1 \\
 t &= q\Delta t, & q &= 0, 1, \dots, M_3 - 1
 \end{aligned}
 \tag{6}$$

In equations (2) and (6)

$$\begin{aligned}
 M_1 &= 2^{m_1} = v_1 N_1 > N_1 = 2^{n_1} \\
 M_2 &= 2^{m_2} = v_2 N_2 > N_2 = 2^{n_2} \\
 M_3 &= 2^{m_3} = v_3 N_3 > N_3 = 2^{n_3}
 \end{aligned}
 \tag{7}$$

$$\begin{aligned}
 \Delta x &= 2\pi/M_1 \Delta k_1 = 2\pi/v_1 k_{1u} \\
 \Delta y &= 2\pi/M_2 \Delta k_2 = 2\pi/v_2 k_{2u} \\
 \Delta t &= 2\pi/M_3 \Delta \omega = 2\pi/v_3 \omega_u
 \end{aligned}
 \tag{8}$$

If a random pressure acting on a structural surface can be assumed to be uniformly distributed in space, equation (2) reduces to one-dimensional simulation

$$P(t) = \text{Re} \left[\sum_{r=0}^{M-1} A_r e^{i\phi_r} e^{i\omega_r t} \right]
 \tag{9}$$

where

$$A_r = [2S_p(\omega_r)\Delta\omega]^{\frac{1}{2}} \quad (10)$$

and $S_p(\omega)$ is the power spectral density of random pressure $p(t)$.

In order that random pressure can be simulated either from equation (2) or equation (9), the input spectral densities need to be prescribed. Empirical forms of cross-spectral densities or spectral densities are available for jet noise, turbulent boundary layer flow pressure and rocket noise, etc. [13-16]. Useful approximations can be obtained by assuming the input pressure to be uniformly distributed over the structural component surface. Then, the cross-spectral density can be approximated by a band-limited Gaussian white noise

$$S_p(\xi, \eta, \omega) = \begin{cases} S_o & \text{if } \omega_l \leq \omega \leq \omega_u \\ 0 & \text{if } \omega < \omega_l \text{ or } \omega > \omega_u \end{cases} \quad (11)$$

in which ω_l and ω_u indicate the lower and the upper cut-off frequencies. The expression for S_o can be written

$$S_o = \frac{p_o^2}{\Delta\omega} 10^{SPL/10} \quad (12)$$

where p_o is the reference pressure, $p_o = 2.9 \times 10^{-9}$ psi (0.00002 N/m²), $\Delta\omega$ is the selected bandwidth, and SPL is the sound pressure level expressed in decibels.

2.2 Simulation of Multivariate Random Process

There are many problems of interest where the time histories of random point forces are required. Consider a set of stationary and Gaussian random processes $F_j(t)$, $j = 1, 2, \dots, K$. Assume the mean value is zero for each of F_j . Then, the random processes can be simulated as [11,12]

$$F_j(t_q) = \sqrt{2\Delta\omega} \operatorname{Re} \left\{ \bar{F}_j(t_q) \right\} \quad (13)$$

where

$$\bar{F}_j(t_q) = \sum_{m=1}^j \sum_{l=1}^{M-1} |H_{jm}(\omega_l)| e^{i[\theta_{jm}(\omega_l) + \phi_{ml}]} e^{i\omega_l t_q} \quad (14)$$

and the matrix $H_{jm}(\omega_l)$ is constructed from the cross-spectral density matrix $[S_F(\omega)]$ of the generalized random forces $F_j(t)$ [12]. The phase angles are

$$\theta_{jm}(\omega_l) = \tan^{-1} \left\{ \frac{\operatorname{Im} [H_{jm}(\omega_l)]}{\operatorname{Re} [H_{jm}(\omega_l)]} \right\} \quad (15)$$

In equation (14), ϕ_{ml} are the random phase angles uniformly distributed between 0 and 2π ,

$$\Delta\omega = \omega_u/N$$

$$N = 2^n, n = 1, 2, \dots$$

$$M = 2^m, m = 1, 2, \dots$$

$$t_q = q\Delta t, q = 0, 1, 2, \dots, M-1$$

$$\Delta t = 2\pi/(M\Delta\omega) = 2\pi/(v\omega_u)$$

$$v = 2^{m-n}, m > n \quad (16)$$

In equation (16), N is the number of frequency divisions on cross-spectral densities $[S_F(\omega)]$ and M is the total number of simulation points. The calculation of matrix $\{H(\omega)\}$ can be found in Ref. 12.

2.3 Nonlinear Response of Surface Panels Subjected to High Intensity Noise

The time domain solutions for nonlinear deflection and stress response of homogeneous panels, discretely stiffened panels and panels made from composite materials have been developed in Refs. 1-10. These solutions were obtained utilizing a Galerkin type procedure and numerical integration of the governing equations of motion in time domain. To illustrate this procedure, consider a homogeneous panel shown in Fig. 1, exposed to random pressure $p(x,y,t)$. The random input pressure is assumed to be of magnitude to cause the panel to vibrate in a nonlinear fashion. Thermal, cavity, nonsteady aerodynamic and in-plane loads are not included in the formulation. Then, utilizing von Karman's theory of large deflection of thin plates, the governing equations of motion are

$$D\nabla^4 w + c\dot{w} + m_p\ddot{w} - N_x \frac{\partial^2 w}{\partial x^2} - N_y \frac{\partial^2 w}{\partial y^2} + 2N_{xy} \frac{\partial^2 w}{\partial x \partial y} = p(x,y,t) \quad (17)$$

$$\nabla^4 F = Eh \left[\left(\frac{\partial^2 w}{\partial x \partial y} \right)^2 - \frac{\partial^2 w}{\partial x^2} \cdot \frac{\partial^2 w}{\partial y^2} \right] \quad (18)$$

where F is the Airy stress function and $D = Eh^3/12(1-\nu^2)$, E, h, m_p, ν are modulus of elasticity, plate thickness, mass per unit area and Poisson's ratio, respectively. The membrane in-plane forces N_x, N_y and N_{xy} are given by

$$\begin{aligned} N_x &= \partial^2 F / \partial y^2 \\ N_y &= \partial^2 F / \partial x^2 \\ N_{xy} &= -\partial^2 F / \partial x \partial y \end{aligned} \quad (19)$$

The in-plane displacements u and v are expressed as

$$\frac{\partial u}{\partial x} = \frac{1}{Eh} \left(\frac{\partial^2 F}{\partial^2 y} - \nu \frac{\partial^2 F}{\partial^2 x} \right) - \frac{1}{2} \left(\frac{\partial w}{\partial x} \right)^2 \quad (20)$$

$$\frac{\partial v}{\partial y} = \frac{1}{Eh} \left(\frac{\partial^2 F}{\partial^2 x} - \nu \frac{\partial^2 F}{\partial^2 y} \right) - \frac{1}{2} \left(\frac{\partial w}{\partial y} \right)^2 \quad (21)$$

The in-plane boundary conditions are satisfied on the average

$$\int_0^b \int_0^a \frac{\partial u}{\partial x} dx dy = 0 \quad (22)$$

$$\int_0^a \int_0^b \frac{\partial v}{\partial y} dx dy = 0 \quad (23)$$

$$\frac{1}{b} \int_0^b N_{xy} \Big|_{x=0,a} dy = 0 \quad (24)$$

$$\frac{1}{a} \int_0^a N_{yx} \Big|_{y=0,b} dx = 0 \quad (25)$$

Equations (22) and (23) imply no in-plane stretching of the panel edges (immovable edges) and equations (24) and (25) indicate zero shear forces at the edges.

To solve equations (17) and (18) panel normal deflections are expanded in terms of modes $\phi_{mn}(x,y)$ such that

$$w(x,y,t) = \sum_{m=1}^{\infty} \sum_{n=1}^{\infty} A_{mn}(t) \phi_{mn}(x,y) \quad (26)$$

in which A_{mn} are modal amplitudes. Substituting equation (26) into equation (18) and satisfying the in-plane boundary conditions, the solution for the Airy stress function F can be developed [2-5]. Then utilizing this solution, the Galerkin type procedure and equations (17) and (26), a system of nonlinear differential equations in the generalized coordinates A_{mn} is obtained. After the simulation of the random input pressure $p(x,y,t)$, the nonlinear equations of motion are solved in time domain utilizing a numerical integration procedure.

The nonlinear stresses of the isothermal panel can be calculated from

$$\sigma_x = -\frac{Ez}{1-\nu^2} \left(\frac{\partial^2 w}{\partial x^2} + \nu \frac{\partial^2 w}{\partial y^2} \right) + \frac{1}{h} N_x \quad (27)$$

$$\sigma_y = -\frac{Ez}{1-\nu^2} \left(\frac{\partial^2 w}{\partial y^2} + \nu \frac{\partial^2 w}{\partial x^2} \right) + \frac{1}{h} N_y \quad (28)$$

$$\tau_{xy} = -\frac{Ez}{1+\nu} \frac{\partial^2 w}{\partial x \partial y} + \frac{N_{xy}}{h} \quad (29)$$

where z is the distance from the midplane of the panel. The first set of terms in equations (27-29) correspond to bending stresses and the second term to stresses due to midplane stretching.

2.4 Sonic Fatigue

The nonlinear response leads to a non-Gaussian distribution of stress amplitude. A starting point in developing a damage theory that is consistent with the present time domain approach for nonlinear/non-Gaussian response is to utilize fatigue data from constant amplitude coupon testing. The stress versus the number of cycles can be written as

$$S^\lambda = B/N \quad (30)$$

where S is a fixed stress amplitude for constant amplitude loading, N is the number of stress cycles until failure, and λ and B are material constants. The cumulative damage can be written as [17]

$$D = \sum_i n_i/N_i \quad (31)$$

in which n_j represents the actual number of cycles at a given stress level and N_j is the number of total cycles at which failure occurs at the same stress level. Combining equations (30) and (31)

$$D = \frac{1}{B} \sum_i n(S_i) |S_i|^\lambda \quad (32)$$

where an absolute sign is introduced to account for positive stress peaks that might occur in the negative stress region. Let now $D(t)$ given in equation (32) represent the random accumulated damage per unit time due to continuous random stress $S(t)$. Then, it can be shown that the expected fatigue damage in a time interval τ is [18]

$$E[D(\tau)] = \frac{E[M_\tau] \tau}{B} \int_{-\infty}^{\infty} |S|^\lambda p_I(S) dS \quad (33)$$

where $p_I(S)$ is the probability density function of the stress peak magnitude. These probability density functions are determined as histograms directly from the nonlinear stress response time history. For a stationary stress response, fatigue life can be computed from equation (33) by setting $E[D(\tau)] = 1$. The expected total number of peaks $E[M_T]$ can be estimated from [18]

$$E[M_T] = - \int_{-\infty}^{\infty} \int_{-\infty}^0 \ddot{s} P_{s\dot{s}\ddot{s}}(s, 0, \ddot{s}) d\ddot{s} ds \quad (34)$$

where $P_{s\dot{s}\ddot{s}}$ is the joint probability density of S (stress), \dot{S} (stress velocity), and \ddot{S} (stress acceleration).

REFERENCES

1. Shinozuka, M., "Monte Carlo Solution of Structural Dynamics," International Journal of Computers and Structures, Vol. 1, 192, pp. 855-874.
2. Vaicaitis, R., Jan, C.M. and Shinozuka, M., "Nonlinear Panel Response and Noise Transmission from a Turbulent Boundary Layer by a Monte Carlo Approach," AIAA Paper No. 72-199, AIAA 10th Aerospace Sciences Meeting, San Diego, Cal. January 17-19, 1972.
3. Vaicaitis, R., Dowell, E.H. and Ventres, C.S., "Nonlinear Panel Response by a Monte Carlo Approach," AIAA Journal, Vol. 12, No. 5, May 1974.
4. Vaicaitis, R., "Nonlinear Panel Response to Nonstationary Wind Forces," Journal of the Engineering Mechanics Division ASCE, Vol. 101, No. 4, August 1975, p. 333-347.
5. Hong, H.K. and Vaicaitis, R., "Nonlinear Response of Double Wall Sandwich Panels," Journal of Structural Mechanics, 12(4), (84-85) pp. 483-503.
6. Vaicaitis, R., "Acoustic Fatigue - A Monte Carlo Approach," AIAA/ASME/ASCE/AHS 28th SDM Conference, Paper No. 87-0916, Monterey, CA., April 6-8, 1987.
7. Vaicaitis, R. and Choi, S., "Response of Stiffened Panels For Application to Acoustic Fatigue," AIAA 11th Aeroacoustics Conference, Paper No. 87-2711, Sunnyvale, CA., Oct. 19-21, 1987.
8. Vaicaitis, R. and Choi, S.T., "Acoustic Fatigue of Stiffened Structures," Proceedings of the Third Conference on Recent Advances in Structural Dynamics, Southampton, England, 1988.
9. Choi, S.T. and Vaicaitis, R., "Nonlinear Response and Fatigue of Stiffened Panels," Probabilistic Engineering Mechanics, Vol. 4 No. 3, Sept. 1989.
10. Vaicaitis, R. and Arnold, R.R., "Nonlinear Response and Sonic Fatigue of Metal and Composite Panels," paper No. 90-3938, 13th Aeroacoustic Conference, AIAA, Oct. 22-24, 1990.
11. Vaicaitis, R., "Generalized Random Forces for Rectangular Panels," AIAA Journal, Vol. 11, No. 7, July 1973, pp. 984-988.

12. Shinozuka, M. (Editor), Stochastic Mechanics, Vol. I and II, Dept. of Civil Engineering and Engineering Mechanics, Columbia University, New York, NY, 1987.
13. Coe, C.F. and Chyu, W.J., "Pressure Fluctuation Inputs and Response of Panels Underlying Attached and Separated Supersonic Turbulent Boundary Layers," NASA TM X-62, 189, 1972.
14. Maestrello, L., "Radiation from Panel Response to a Supersonic Turbulent Boundary Layer," Journal of Sound and Vibration, Vol. 10, No. 2, 1969, pp. 261-295.
15. Cockburn, J.A. and Jolly, A.C., "Structural-Acoustic Response, Noise Transmission Losses and Interior Noise Levels of an Aircraft Fuselage Excited by Random Pressure Fields," AFFDL-TR-68-2, Air Force Flight Dynamics Laboratory, Wright-Patterson Air Force Base, Ohio, August 1968.
16. Ojalvo, I.U., Levy, A. and Austin, F., "Thermal Stress Analysis of Reusable Insulation for Shuttle," NASA CR-132502, 1974.
17. Miner, M.A., "Cumulative Damage in Fatigue," Journal of Applied Mechanics, Transactions of the ASME, Vol. 12, 1945,
18. Lin, Y.K., Probabilistic Theory of Structural Dynamics, McGraw-Hill, New York, 1967.

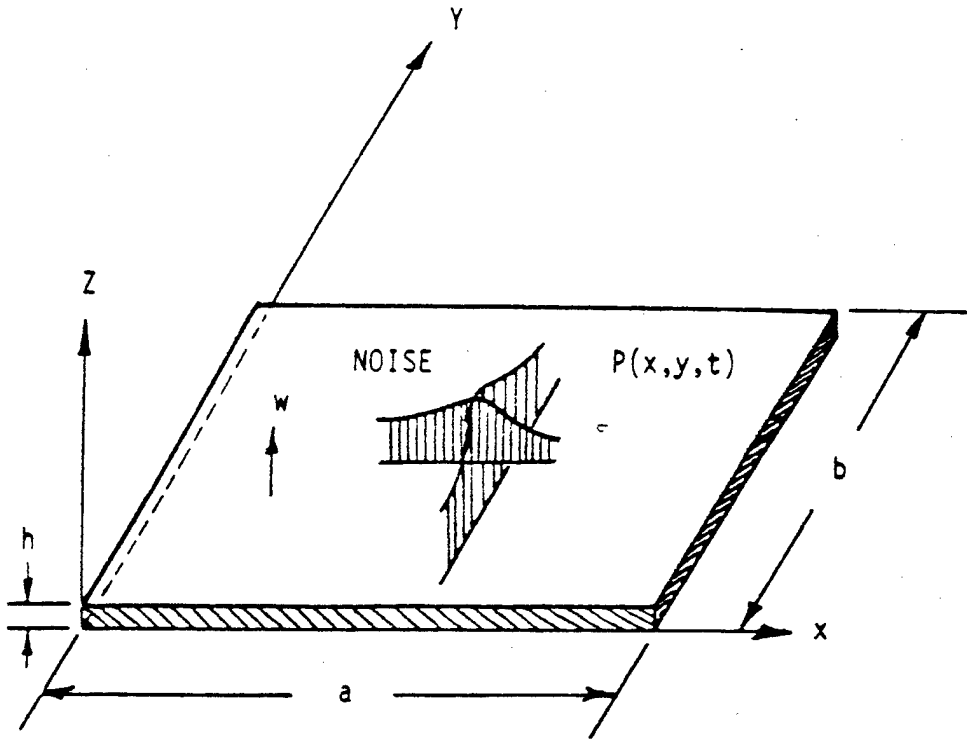

Figure 1 A Rectangular Panel Exposed to Random Pressure