

X-ey

24610245

"IRON BIRD" MODEL
FOR
AGILE PORGRAM
PART II

JULY 1984

19990518 064

Approved for Public Release:
Distribution Unlimited

**AEROSPACE STRUCTURES
INFORMATION AND ANALYSIS CENTER**

**OPERATED FOR THE AIRFORCE FLIGHT DYNAMICS LABORATORY
BY ANAMET LABORATORIES, INC.**

PREFACE

This report was prepared by William H. Kuntz of Delta Dynamics, Inc. for the Flight Dynamics Laboratory (FDL), Air Force Wright Aeronautical Laboratories, (AFWAL), Wright-Patterson AFB, Ohio. The work was performed within the scope of the Aerospace Structures Information and Analysis Center, which is operated for the Flight Dynamics Laboratory by Anamet Laboratories, Inc. under Contract No. F33615-81-C-3201. The work was accomplished under Anamet Purchase Order No. 3411. Mr. Gordon R. Negaard, was the project monitor for Anamet Laboratories, Inc.

"IRON BIRD" MODEL
FOR
LABORATORY INVESTIGATION OF
AIRCRAFT GROUND INDUCED LOADS EXCITATION
AGILE PROGRAM

FEASIBILITY STUDY

CONTENTS

Feasibility Study	page 1
Model design	Appendix I
F-15 1/8 Scale Model	Appendix II
Cost Estimate	Appendix III

JULY 1984

DELTA DYNAMICS, INC.

DAYTON, OHIO

SUBJECT:

FEASIBILITY STUDY OF FULL SCALE DYNAMIC SIMULATION OF AIRCRAFT STRUCTURES FOR THE AGILE PROGRAM

PURPOSE:

To generate practical designs and provide cost estimates for the F-4, F-15, and F-16 simulations (IRON BIRDS) in response to a request from FIBR.

DISCUSSION:

1) A number of test programs have been conducted using instrumented aircraft operating over runways on which bumps due to runway repair have been simulated. The tests are reported to be expensive because of the operational costs of using actual aircraft and any structural damage resulting from the tests adds to the cost. In addition, the data are often non-repeatable because of the large number of variables involved. Correlation with theory is therefore difficult.

2) The idea of using laboratory tests has been proposed as an alternative under the name "Agile" i.e. "Aircraft Ground Induced Load Excitation". In this project, excitation will be applied to the test aircraft by means of hydraulic shakers located under each of the landing gear. The objective is to partially simulate rough field operation under a controlled environment to obtain consistent data at relatively low cost. These test data will include direct measurements of structural accelerations which will be correlated with theory. It is expected that this correlation will assist in the development of improved math models for dynamic load prediction and for the evaluation of new landing gear concepts which may be proposed to reduce the loads caused by rough runway operation.

3) If the models include simulations of important non-linear effects, the testing of full scale dynamic models in lieu of actual aircraft for Agile will provide the correct information on the loads, shears, moments and strain energies. However, the stresses will be correct only for the actual aircraft components used on the model such as the landing gear, stores and pylons. Calculations or tests using the loads obtained from the dynamic model test data will have to be conducted to determine the stresses in other parts of the aircraft such as the wing and fuselage structures and the actual fittings used on the aircraft to attach the landing gear and pylons. Nevertheless, the use of models in lieu of actual aircraft has been considered for the following reasons:

a) The costs involved when an actual aircraft is used for the tests are believed to be much greater than the costs of a model.

b) Limitations on the test environment may be required to avoid structural damage to an actual airplane. The model can be designed to withstand higher loads and can be repaired at lower costs.

c) The cost of modifying the model to accept a new landing gear design is expected to be much less than the cost of modifying an actual aircraft.

d) The use of a model may permit the simulation of aircraft which have not been built as well as the simulation of aircraft too large to be tested with available shakers. However a reduction in scale will cause a corresponding reduction in the deflections due to gravity, so that methods of compensating for these reduced deflections will be needed.

4) The feasibility of the model approach depends primarily on the cost of building the model. Minimum costs may be achieved by selecting design features that make use of standard stock sizes, by shearing or torch cutting the outline of parts which will be assembled by welding, by eliminating the need for expensive tooling, jigs and fixtures and by compromises in the dynamic simulation.

5) The compromises in dynamic simulation proposed for Agile are as follows:

a) The wing will be designed for the bending and torsional stiffnesses and the weight distribution. The centers of gravity and pitch moments of inertia will not be precisely scaled since the torsional frequency of the wing without stores is expected to be too high to be a critical dynamic loading frequency for Agile. In addition, the masses of the stores are expected to contribute the major portions of the effective masses of the wing vibration modes excited during Agile testing.

b) The tail will not be scaled since the natural frequencies of the tail modes are expected to be too high to produce significant dynamic loads in the Agile environment.

c) The fuselage will be designed for the correct mass distribution along the longitudinal axis, the correct vertical bending stiffness between the main and nose gear and the approximate vertical bending stiffnesses elsewhere. The use of a round tube, as discussed in sect. 7), will result in reasonable values for the lateral bending and torsional stiffnesses.

6) The design approach used for the wing was as follows :

a) About 75% of the allowable weight per inch of span is used to calculate the cross-section areas of the top and bottom plates depending on the material selected. Since aluminum is about $1/3$ the density of steel, an aluminum alloy wing will have three times the cross-section area of a steel wing.

b) The vertical spacing between the top and bottom plates is determined from the vertical bending stiffness or "EI" of the wing. Since "E" for steel is three times "E" for aluminum, the moment of inertia for steel will be $1/3$ that for aluminum. However the mean spacing between the top and bottom plates will be the same for both materials, since the area of steel is one third of the area for aluminum as pointed out in a) above.

c) The widths of the top and bottom plates are determined from the moments of inertia in fore and aft bending.

d) The fore and aft spacing of the main spars is computed from the torsional stiffness. Intermediate spars if used are spaced at about 30 times the thickness of the top and bottom plates to prevent buckling.

e) The strength depends on the material selected since EI is fixed and the bending stress is approximately equal to the bending moment divided by the product of the mean plate spacing and the cross-section area of one of the plates. For example, if steel is used, the stress will be about three times the stress in aluminum since as pointed out above the mean plate spacing will be about the same in both cases and the area of steel is $1/3$ the area of the aluminum.

f) A special weldable aluminum alloy either 7005 or 7039 was selected for the wing since the ultimate tensile stress has been reported to be in the neighborhood of 60,000 p.s.i. and no heat treatment is required after welding. To obtain equal strength with steel, a 180,000 p.s.i. allowable would be needed and three times as many intermediate spars would be used since the steel plates will have about one third the thicknesses of the aluminum plates. The limited information available to Delta Dynamics at this time indicates that the only disadvantage to the above alloys is that they must be purchased directly from the manufacturer in 7,000 pound lots for each thickness required for the model.

7) The design approach used for the fuselage was as follows:

a) A tubular or solid cylindrical structure providing approximately the correct weight per inch of length and "EI" in

vertical bending was sought because built up rectangular or square structural designs would require extensive welding and the addition of weights, if required, would increase the costs.

b) The material selection was based on stress considerations as well as the costs of fabrication. The stress due to a bending moment M is given by MR/I where "R" is the radius of the tube or cylindrical bar. Since "I" for the aluminum fuselage is three times "I" for the steel fuselage and "I" is proportional to the fourth power of the radius for a solid bar, the stress in aluminum will be about 44% of the stress in steel. For the heavy walled tubing proposed in this simulation, the reduction of stress using an aluminum alloy tube will be slightly larger. The stress in aluminum will however drop to one-third of the stress in steel, for designs in which the mean radii are the same for the aluminum and steel fuselages.

c) Despite the higher stress levels, steel tubing was selected over aluminum because of the lower cost per pound, the ease in welding attachment fittings and the large ratio of non structural to structural weight which exists in the fuselages of the aircraft selected for simulation. In addition steel tubing in the sizes required to meet the design criteria in a) above appears to be readily available while aluminum tubing or bar stock would have to be ordered special.

d) Stress analyses conducted for the fuselage simulated by a steel tube with a heavy wall show margins that appear to be adequate for Agile because the outside radius of the model fuselage is less than one third of the fuselage radius. In cases where a large reduction in radius is not practical because of weight limitations, an aluminum alloy fuselage might have to be used to withstand the stresses imposed by the AGILE environment.

e) Shear deflections on the model fuselage will be substantially less than on the airplane because the reduction in radius requires an increase in cross sectional area to obtain the same stiffness and it may be necessary to reduce "EI" on the model somewhat to compensate. However, it appears likely that shear effects will not be substantial for the modes being simulated for Agile.

B) The attachment of landing gear and stores could substantially increase the model costs if the complicated fittings used on certain aircraft are employed. The solutions proposed are as follows:

a) Steel fittings will be bolted to the wing carry-through structure to fasten the main gear and to the fuselage to fasten the nose gear. No structure will be added for landing gear retraction.

b) The pylons will be bolted to blocks welded to the wing structure and actual pylons and stores will be used if available. Store ejection mechanisms will not be simulated.

c) In the event that actual pylons require complicated fittings, simulated pylons that can be bolted directly to blocks welded to the wing structure are proposed.

9) The costs of fabricating the models cannot be predicted with great confidence because no simple procedure could be found for accurately computing the hours required for: a) handling the component parts of the model structure, b) welding including setups, and c) assembling the model with proper allowance for assembly problems. The substantial expenditures that seem to be required to develop precise cost estimating procedures for the Iron Bird project do not appear to be justified since the costs of the proposed designs are expected to be close to minimum. An approximate cost estimate was made using the following procedure:

a) The costs of the materials were obtained from the suppliers.

b) The fabrication costs were estimated for each step in the fabrication process.

c) The assembly costs were estimated with allowances for assembly problems.

10) Details concerning the cost analysis are contained in Appendix III. Major cost items are as follows:

a) The costs of the wing material could be about \$75,000 because the minimum order for the special alloy used is about \$15,000 for each size and five different sizes will be required. The weight of the minimum order is 7,000 pounds so 35,000 pounds will be on hand while 4100 pounds is about the maximum required for any one of the three Iron Birds. Two possibilities exist for reducing the costs of the wing material: 1) etch or machine the special aluminum alloy to reduce the number of sizes required and, 2) replace the special alloy with 6061 and heat-treat the wing. Machining seems preferred at this time even though no precise cost figures could be obtained. An estimate for etching the F-16 wing covers was \$2800 per cover compared to \$1200 for machining. The use of 6061 appears impractical because the heat-treating of large structures which may require modification and frequent repair would be expensive and time consuming.

b) The steel tubing will run about \$0.75 per pound, so \$25,000 should cover steel costs making some allowance for scrap.

c) We have received an estimate from T&R Welding of \$13,055 plus material costs for fabricating an Iron Bird for the F-16. This quotation does not include the installations of the landing gear and stores, the fabrication of any special fittings required or the costs of any modifications needed for Agile applications. Despite the above estimate, our experience with the fabrication of experimental items indicates that substantial overruns can occur because of engineering errors, unforeseen technical difficulties, shop errors, non productive labor hours and the difficulties of accurately predicting the costs mentioned above. On the basis of our experience, we currently estimate that the fabrication cost could be approximately \$75,000 (labor only) for the first Iron Bird.

d) In view of the above, the total cost of the first Iron Bird could be \$175,000. However, the uncertainties will result in such large contingencies in a fixed price quotation that the project, if approved, should probably be carried out thru a cost type of contract with tight cost controls.

e) Substantial reductions in the costs of the additional models are expected for the following reasons: 1) The experience obtained from the first Iron Bird is expected to result in substantially lower fabrication costs, 2) The design includes a common center fuselage and carry through structure for all three aircraft and 3) The cost estimate is based on the assumption that 35,000 pounds of the special alloy will be purchased in the sizes selected for the wing structures even though there is some indication that machining can reduce the amount of material that must be purchased.

11) To check out the feasibility of the F-15 design, a one-eighth scale model of the F-15 Iron Bird was fabricated and tested. Since the F-15 fuselage uses the same tube as the F-16 and is appx. 65% higher in vertical bending stiffness, the stiffness of the main fuselage tube was increased by the addition of a rectangular bar. A portion of this bar was later removed to obtain a better match of the fuselage bending frequency. Larger wing attachment loads for the F-15 required a redesign of the attachment fittings. The F-16 design should be modified to make use of these same attachment fittings. Additional information regarding this model is contained in appendices I and II.

12) The 1/8 scale models have been valuable in disclosing design and fabrication problems which would have been much more difficult and costly to solve on the full scale model.

CONCLUSIONS:

- 1) The fabrication of full scale dynamic simulations (IRON BIRDS) of the F-4, F-15, and F-16 for the Agile test program appears to be practical.
- 2) More accurate cost estimates can be provided by Delta Dynamics after the first Iron Bird has been fabricated.
- 3) The cost estimates that were made are lower than Delta Dynamics would have expected for the sizes and weights of the Iron Birds considered in this report.
- 4) The costs will increase if more accurate dynamic simulations than those proposed in this report are required.

RECOMMENDATIONS:

- 1) Fabrication of full scale Iron Bird models of aircraft for AGILE should not be attempted without test data from reduced scale models.
- 2) Before constructing any full scale models, more comprehensive tests are needed to determine whether the simulation achieved in these 1/8 scale models is acceptable for the purposes of AGILE. Strength tests should be conducted to reveal any potential failures that might occur during shake tests of the full scale models.
- 3) The special aluminum alloy selected for the wing should be thoroughly investigated to uncover any disadvantages which might possibly explain why the material is not available from our regular suppliers.
- 4) A review of aircraft structural damage caused by rough runway operation should be conducted to determine whether or not the proposed compromises contained in this report are permissible in the dynamic simulation of Iron Birds for AGILE.
- 5) If feasible, important non-linear effects should be simulated in the IRON BIRDS.

Submitted By

W.H. Kuntz and

L.S. Wasserman

F-15 - FULL SCALE

MODEL DESIGN

SIMULATION:

Under the AGILE program, shakers will be used to apply programmed motions to the landing gear. The airplane dynamic response is related to particular frequencies and modes. The primary model design objective is to create a physical model that possesses the effective mass and stiffness properties necessary to reproduce the dynamics of the airplane that control these frequencies and modes. The design data is taken from the analytical math model prepared for modal calculations. Neither model attempts to represent the details of the airplane structure. The effect of joints and fittings may only be defined by equivalent stiffness or by influence coefficients. The design of the physical model is done in a way that the major load paths are approximated. When tests have been performed on the physical model and correlation with the airplane and the analytical model is demonstrated, then confidence is established in the use of the analytical model to predict dynamic response loads. The F-15 does not carry a launch rail and missile at the wing tip; therefore, inertia weights were added to the outer panel for a better simulation of the wing mass properties.

STRUCTURE:

An airplane contains many items which are not part of the structure. In a dynamic model, the weight of these parts can be used in the model structure making it possible to design a model structure relatively stronger than the airplane. The design details were selected in accord with this concept and with the objective of minimum fabrication cost.

DISCREPANCIES:

Past experience with building dynamic models (such as flutter models) has shown that the analytical math model may not represent some feature of the airplane. Also, some compromises and trade-offs are necessary in the model design. Therefore, it was believed necessary to fabricate a reduced scale model before attempting to fabricate a full scale model. A 1/8 scale model was fabricated based on the design proposed for the full scale "Iron Bird". Some reduced scale drawings are presented in the following pages.

F-15 - FULL SCALE

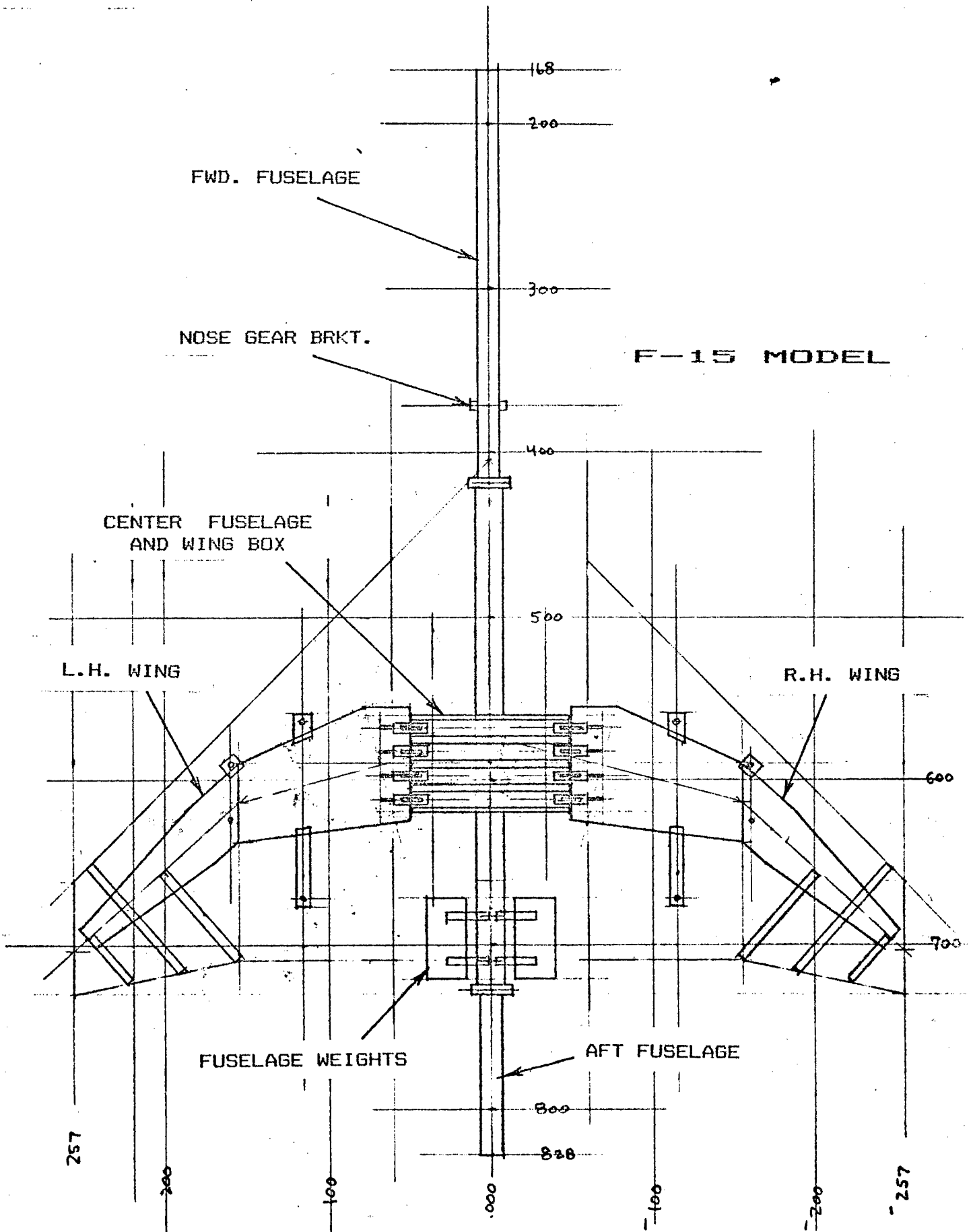

257

200

100

.000

-100

-200

-257

F-15 - FULL SCALE

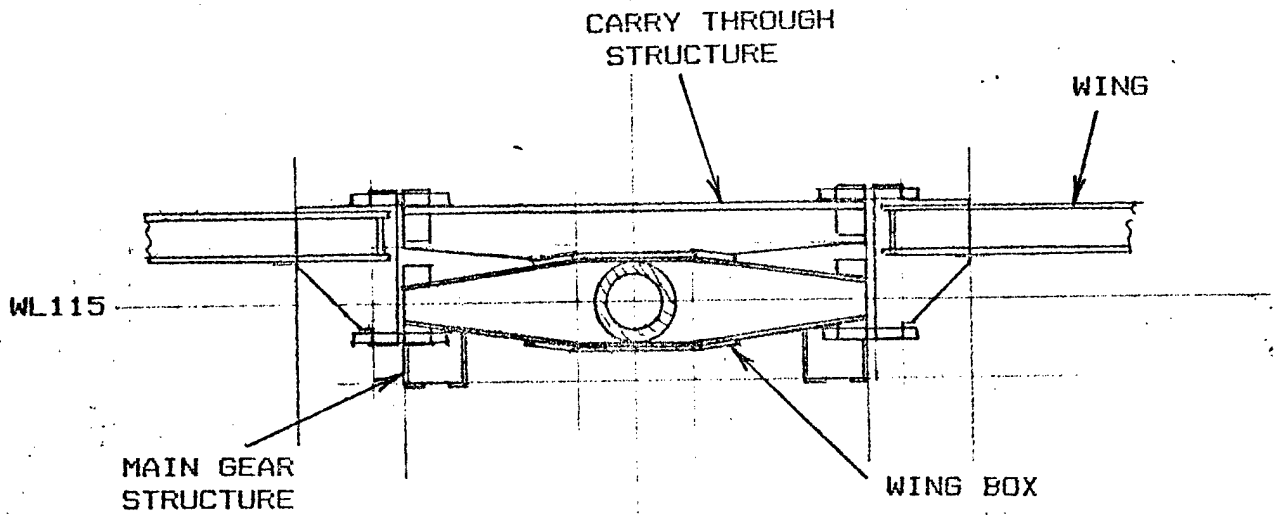

SECT. AT F.S. 590

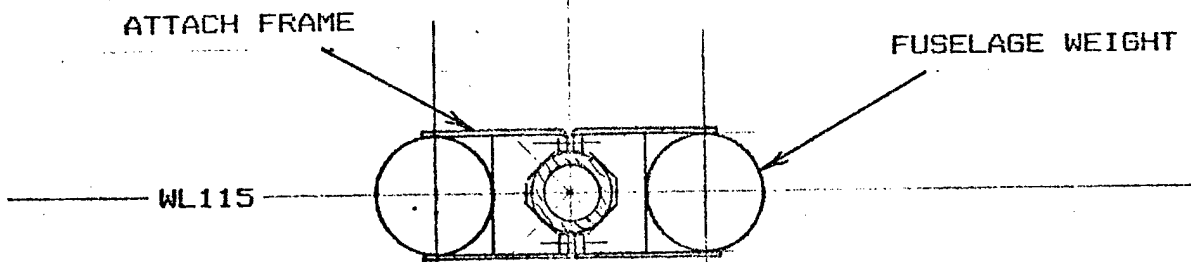

SECT. AT F.S. 700

F-15 MODEL

F-15 - FULL SCALE

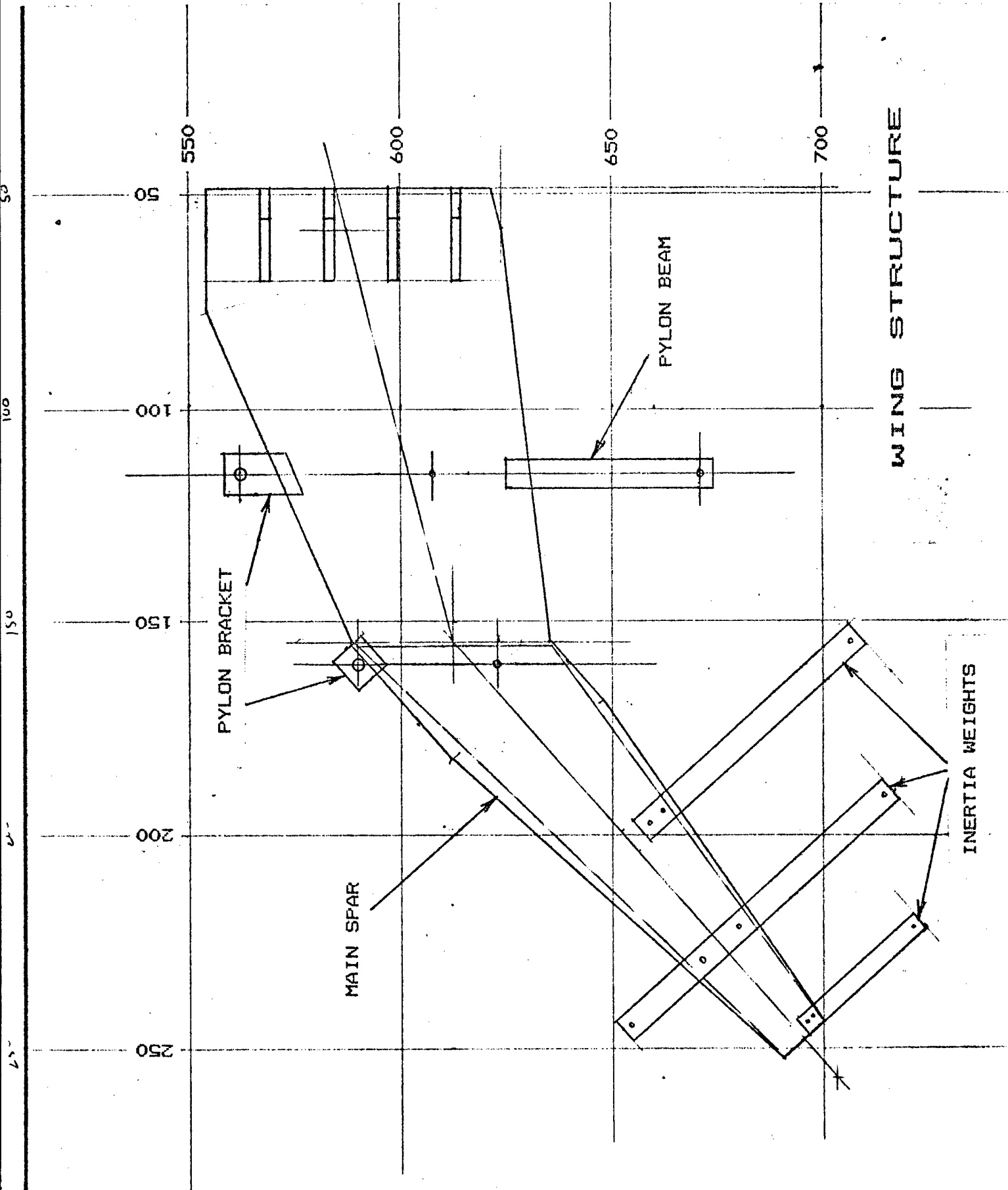

F-15 - 1/8 SCALE

SCALE FACTORS:

Model Target = Airplane value * scale factor.

Property	Symbol	Units	Scale Factor
Length	L	in.	.125
Density	d	lb./in. ³	1.0
Velocity	V	ft./sec.	1.0
Weight/in.	W/L	lb./in.	1.56E-02
Weight	W	lb.	1.95E-03
Unbalance	S	lb.in.	2.44E-04
Inertia	I	lb.in ²	3.05E-05
Linear spring	k	lb./in.	.125
Bending spring	P/theta	lb./rad.	1.56E-02
Torsion spring	M/theta	in.lb./rad.	1.95E-03
Beam stiffness	EI;GJ	lb.in ²	2.44E-04
Frequency	f	Hertz	8.0
Acceleration	A	in./sec ²	8.0
Gravity	G	in./sec ²	.125
Static Defl.	z,s	in.	1.56E-02

NOTE: Since gravity is an acceleration, the model gravity should be 8 times full scale. However, gravity acceleration remains the same as full scale, and the static deflection of the model, caused by scaled masses, is only 1/8 of the linear scaled value for the full scale structure.

F-15 - 1/8 SCALE

MASS PROPERTIES:

Design data was obtained from MCDONNELL AIRCRAFT CORP. report #A2100 for the F-15 airplane for the following conditions:

Fuselage - empty.
Wing - empty.
No pylons or stores.

Item	Airplane	Model - Target
Weight - lb.	29196	57.0
C.G. - inches	564	70.5
I _{y,y} - lb. in. ²	698 E06	21275
I _{x,x} - lb. in. ²	97.6 E06	2977

Consider the airplane with 1949 lb. fuel in fwd. tank at station 450, and without wings:

Item	Airplane	Model - Target
Weight - lb.	28109	54.9
C.G. - inches	551	68.9
I _{y,y} - lb. in. ²	706 E06	21545
I _{x,x} - lb. in. ²	97.6 E06	2977

FUSELAGE ROLL INERTIA:

The design of the model fuselage did not attempt to meet any target for roll inertia. A breakdown of the roll inertia contribution of the various components is given below:

Item	Airplane		Model - Target	
	Weight	I _{x,x} E-05	Weight	I _{x,x}
Fuselage	25120	338		
2 Horiz. tails	562	58		
2 Vert. tails	478	48		
sub total	<u>26160</u>	<u>444</u>	<u>51.1</u>	<u>1354</u>

The fuselage roll radius of gyration was calculated for the following conditions:

Fuselage structure without fuel: R = 36.7
Fuselage - no fuel - including tails: R = 41.2

F-15 - 1/8 SCALE

WING ROLL INERTIA: For one wing panel about its own C.G.

Wing C.G. is at B.L. sta. 123; = Model sta. = 15.38

Item	Airplane		Model Target	
	Weight	I;x,x E-05	Weight	I;x,x
1 Wing	1518	36.3	2.96	111
Transfer to center line:				
	$123^2 * 1518 =$	230		
1 Wing panel	1518	36		
subtotal	<u>1518</u>	<u>266</u>		
2 Wings	3036	532	5.92	1623

TOTAL AIRPLANE ROLL INERTIA:

Fuselage	26160	444		
2 wings:	3036	532		
Airplane	<u>29196</u>	<u>976</u>	57.0	2977

MODEL MASS PROPERTIES:

Data prepared from measurements made on the 1/8 scale model.

MODEL WING PANEL:

Item	1/8 Model	Deviation
Weight - lb.	3.71	.75
C.G. - inches	14.15	1.23 in.
I;x,x - lb. in.^2	166	
Transfer to center line:		
	$14.15^2 * 3.71 =$	743
1 Wing - meas.	3.71	166
Sub total	<u>3.71</u>	<u>909</u>
2 Wings	7.42	1818

F-15 - 1/8 SCALE

Consider the following adjustment for overweight = .75 lb.

$S = 1.23 * 3.71 = 4.56$ due to overweight.
 $4.56 / .75 = 6.08$ location of overweight.
 $15.38 - 6.08 = 9.3$ B.L. of overweight.
 $9.3^2 * .75 = 65 \text{ lb. in}^2$ roll inertia.

Deduct the overweight and roll inertia from wing panel and add to fuselage.

TWO WINGS ABOUT C/L AIRP.:

Item	Measured		Model Target	
	Weight	I;x,x	Weight	I;x,x
2 Wings	7.42	1818	5.92	1623
Adjustment	-1.50	-130		
total	<u>5.92</u>	<u>1688</u>		
Deviation	0.0	+4%		

MODEL FUSELAGE - NO WINGS:

Item	1/8 Model	Target	Deviation
Weight - lb.	53.4	54.9	-1.5
C.G. - inches	68.7	68.9	-.2
I;y,y - lb. in.^2	19363	21545	-10.1%
I;x,x - lb. in.^2	202	1354	-85%

Adjustment for wing overweight = 1.5 lb. at F.S. 75.95; roll inertia = 130 lb. in.^2.

Item	1/8 Model	Target	Deviation
Weight - lb.	54.9	54.9	0.0
C.G. - inches	68.9	68.9	0.0
I;y,y - lb. in.^2	19541	21545	-9%
I;x,x - lb. in.^2	332	1354	-75%

MODEL FUSELAGE WITH WINGS:

I;x,x - lb. in.^2	2020	2977	-32%
-------------------	------	------	------

F-15 - 1/8 SCALE

COMMENTS

The F-15 airplane does not carry a tip store or pylons with stores on the outer panel of the wing. Therefore, inertia weights were added to the wing spar to improve the simulation. The measured mass properties of the model wing and fuselage indicate that the mass distribution is an acceptable simulation of the airplane in accord with the criteria established for the design of the model.

STIFFNESS PROPERTIES:

Stiffness distribution data were obtained from MCDONNELL AIRCRAFT CORP. report #A2100 for the F-15 airplane. These were given in plots of EI and GJ vs. stations for the fuselage and the wing.

FUSELAGE:

The fuselage vertical EI curve was integrated to derive a vertical spring rate at the nose gear relative to the main landing gear location. Steel tubes of constant EI were selected on the basis of this spring rate. The tubes were also selected to obtain the approximate mass distribution for the fuselage. As a means of reducing cost, the main fuselage structure for the F-16 model was used as the basis for the F-15 fuselage. The F-15 fuselage is approximately 60% stiffer than the F-16. This increased stiffness was achieved by the addition of a rectangular bar. Short vertical webs were welded to the main tube at intervals and the bar was welded to these webs. For reconversion back to the F-16 configuration, the webs may be cut with a torch and the bar removed.

WING SPAR:

The wing spar was designed to match the airplane EI and GJ at various stations. The stiffness plots were integrated for a torsion moment and a bending load to obtain target deflection values for comparison with measured model deflections. Due to the break in the elastic axis, separate measurements were made for the inner wing panel and the outer wing panel. The results are presented in the tables below: (All values are in model scale.)

F-15 - 1/8 SCALE

Test loads were applied and the slopes measured perpendicular and parallel to the elastic axis.

Inner Panel load point = B.L. 25.2 F.S. 78.0 EA STA 26.0
Outer Panel load point = B.L. 30.6 F.S. 86.5 EA STA 41.0

B.L. Station	Target values:		Measured values:			
	TORSION	BENDING	TORSION		BENDING	
	Theta/M E-06	Theta/P E-05	Theta/M E-06		Theta/P E-05	
			L.H.	R.H.	L.H.	R.H.
7.4	0.0	0.0	0.0	0.0	0.0	0.0
19.4	4.6	8.0	7.1	7.9	7.2	7.6
19.4	0.0	0.0	0.0	0.0	0.0	0.0
23.1	13	18	15.6	16.5	18.4	18.0
26.9	47	48	59.0	50.8	42.3	37.8
30.2	154	80	142.	170.	57.0	62.1

FREQUENCIES AND MODES:

The modes reported here are limited to those considered to be significant for the AGILE program.

As described in earlier sections, the model was designed to simulate the F-15 airplane using mass and stiffness data obtained from various documents published by McDonnell Aircraft Corp. Normally, if mass and stiffness distributions closely simulate the airplane, then the frequencies and modes will also correspond.

Airplane measured frequencies were scaled and used for comparison with model measured frequencies. Measured mode shapes for the airplane were not available for comparison with model modes. The airplane frequencies were measured for the airplane with full fuel at a weight of 39,185 lb. (76.53 lb. model). The model represents the airplane with partial fuselage fuel at a gross weight of 31,145 lb. (60.8 lb. model).

The basic fuselage spar was selected to represent the F-16 airplane. A rectangular bar was welded to the structure to increase the fuselage EI to represent the F-15 airplane. The measured frequencies showed about +20% for the first mode, and +30% for the second. An examination of the stiffening effect of

F-15 - 1/8 SCALE

the bar, indicated that part of the bar should be removed from the forward tube. When this modification was made, the first frequency was +6%. The target frequency is given for full fuel while the model represents a partial fuel condition. The second frequency was +21%. The second mode is more sensitive to the exact stiffness and mass distribution as well as shear deflection. The model fuselage did not attempt to represent exact distributions or shear deflections.

The first wing bending A/S mode was appx. 12% high. This may be attributed to the low value for the fuselage roll inertia and also the wing is represented without fuel.

AIRPLANE MEASURED MODES:

Mode	Freq.- Hz	
	Symmetric	Anti-symm.
First Fuselage Bend	8.48	
First Wing Bend	9.97	11.7
Second Fuselage Bend	17.8	
Second Wing Bend	22.1	26.5
Wing Torsion	37.0	37.6

1/8 SCALE MODEL MODES:

Mode	Target Freq.- Hz		Meas. Freq.- Hz	
	Symm.	A/S	Symm.	A/S
First Fuselage Bend	67.8		72	
First Wing Bend	79.8	93.6	78	105
2nd. Fuselage Bend	142		172	
Second Wing Bend	177	212	174	215
Wing Torsion	296	301	320	325

CONCLUSION

Discrepancies in mass, stiffness and frequency can be reduced by further development work on the model. The worst discrepancy is the low roll inertia of the fuselage which is caused by the absence of tail surfaces and the small diameter of the fuselage tube which was selected to reduce costs and the stress level. Weights can be added to increase the roll inertia if necessary. However, the fabrication and testing of the 1/8 scale model demonstrate that it is feasible to simulate the dynamic properties of the F-15 airplane with this relatively simple structure which is considered adequate for use in conducting shake tests for the AGILE program.

FULL SCALE MODEL

COST ESTIMATE:

An estimated cost breakdown for fabrication and materials was presented in the earlier report for the F-16 model.

It appears that the earlier estimate should be revised upward in consideration of the following:

- 1 - General increases in material and labor costs.
- 2 - Additional engineering time is needed to evaluate the 1/8 scale models and make changes where necessary.

The previous total cost estimate was: \$154,600

The revised total cost estimate is: \$200,000