

**REPORT DOCUMENTATION PAGE**Form Approved  
OMB No. 074-0188

Public reporting burden for this collection of information is estimated to average 1 hour per response, including the time for reviewing instructions, searching existing data sources, gathering and maintaining the data needed, and completing and reviewing this collection of information. Send comments regarding this burden estimate or any other aspect of this collection of information, including suggestions for reducing this burden to Washington Headquarters Services, Directorate for Information Operations and Reports, 1215 Jefferson Davis Highway, Suite 1204, Arlington, VA 22202-4302, and to the Office of Management and Budget, Paperwork Reduction Project (0704-0188), Washington, DC 20503

|   |   |  |  |  |
|---|---|--|--|--|
| <b>1. AGENCY USE ONLY (Leave blank)</b>   |   | <b>2. REPORT DATE</b><br>1996                              | <b>3. REPORT TYPE AND DATES COVERED</b>                        |  |
| <b>4. TITLE AND SUBTITLE</b><br>Combustion control using a multiplexed diode-laser sensor system  |   |  | <b>5. FUNDING NUMBERS</b><br>N/A                               |  |
| <b>6. AUTHOR(S)</b><br>E.R. Furlong, D.S. Baer, R.K. Hanson   |   |  |  |  |
| <b>7. PERFORMING ORGANIZATION NAME(S) AND ADDRESS(ES)</b><br>High Temperature Gasdynamics Laboratory<br>Department of Mechanical Engineering<br>Stanford University<br>Stanford, CA 94305-3032  |   |  | <b>8. PERFORMING ORGANIZATION REPORT NUMBER</b><br>N/A         |  |
| <b>9. SPONSORING / MONITORING AGENCY NAME(S) AND ADDRESS(ES)</b><br>SERDP<br>901 North Stuart St. Suite 303<br>Arlington, VA 22203  |   |  | <b>10. SPONSORING / MONITORING AGENCY REPORT NUMBER</b><br>N/A |  |
| <b>11. SUPPLEMENTARY NOTES</b><br>presented at the 1996 Combustion Symposium, Italy. The United States Government has a royalty-free license throughout the world in all copyrightable material contained herein. All other rights are reserved by the copyright owner.   |   |  |  |  |
| <b>12a. DISTRIBUTION / AVAILABILITY STATEMENT</b><br>Approved for public release: distribution is unlimited   |   |  | <b>12b. DISTRIBUTION CODE</b><br>A                             |  |
| <b>13. ABSTRACT (Maximum 200 Words)</b><br>A multiplexed diode-laser sensor system, comprised of two InGaAsP diode lasers and fiber-optic components, has been developed to non-intrusively measure temperature and species concentration over a single path for closed-loop process control using laser absorption spectroscopy techniques. The system was applied to measure and control the gas temperature in the post-flame gases 6 mm above the surface of a Hecken burner. The wavelengths of the lasers were independently current-tuned H <sub>2</sub> O Transitions near 1343 nm and 1392 nm. Temperature was determined from the ratio of measured peak absorption coefficients. H <sub>2</sub> O concentration was determined from the measured absorption coefficient of one transition set at the measured temperature. The mean temperatures recorded compared well with those measured by a thermocouple. Temperature fluctuations up to 250 Hz were accurately measured with the sensor system, demonstrating the high bandwidth of the measurement technique. |   |  |  |  |
| <b>14. SUBJECT TERMS</b><br>SERDP; SERDP Collection; multiplexed,   |   |  | <b>15. NUMBER OF PAGES</b><br>24                               |  |
|   |   |  | <b>16. PRICE CODE</b> N/A                                      |  |
| <b>17. SECURITY CLASSIFICATION OF REPORT</b><br>unclass.  | <b>18. SECURITY CLASSIFICATION OF THIS PAGE</b><br>unclass. | <b>19. SECURITY CLASSIFICATION OF ABSTRACT</b><br>unclass. | <b>20. LIMITATION OF ABSTRACT</b><br>UL                        |  |

NSN 7540-01-280-5500

Standard Form 298 (Rev. 2-89)  
Prescribed by ANSI Std. Z39-18  
298-102

DTIC QUALITY INSPECTED 4

19990521 137

presented at the 1996 Combustion Symposium, Italy

**COMBUSTION CONTROL USING A MULTIPLEXED DIODE-LASER SENSOR SYSTEM**

E. R. FURLONG, D. S. BAER, AND R. K. HANSON

*High Temperature Gasdynamics Laboratory  
Department of Mechanical Engineering  
Stanford University, Stanford, CA 94305-3032*

**Abstract**

A multiplexed diode-laser sensor system, comprised of two InGaAsP diode lasers and fiber-optic components, has been developed to non-intrusively measure temperature and species concentration over a single path for closed-loop process control using laser absorption spectroscopy techniques. The system was applied to measure and control the gas temperature in the post-flame gases 6 mm above the surface of a Hencken burner (multiple CH<sub>4</sub>-air diffusion flames). The wavelengths of the lasers were independently current-tuned across H<sub>2</sub>O transitions near 1343 nm ( $\nu_1+\nu_3$  band) and 1392 nm ( $2\nu_1, \nu_1+\nu_3$  bands). Temperature was determined from the ratio of measured peak absorption coefficients. H<sub>2</sub>O concentration was determined from the measured absorption coefficient of one transition set at the measured temperature. The mean temperatures recorded compared well with those measured by a thermocouple. Temperature fluctuations up to 250 Hz were accurately measured with the sensor system, demonstrating the high bandwidth of the measurement technique. A computer-controlled closed-loop feedback circuit controlled the flame temperature in the probed region by adjusting the fuel flow in response to the difference between the measured and desired gas temperature. The results obtained with this first-generation system demonstrate the potential of multiplexed diode lasers for rapid, continuous, non-intrusive, *in situ* measurements and control of combustion environments.

## Introduction

Non-intrusive measurements of multiple flowfield parameters have been demonstrated in a variety of flows using diode-laser absorption diagnostics [1-3]. Recently, the outputs of three, independently operated, diode lasers have been multiplexed into a single path using fiber-optic components to probe multiple absorption transitions of H<sub>2</sub>O and O<sub>2</sub>, or H<sub>2</sub>O and CH<sub>4</sub>, simultaneously [4,5]. These multi-species sensor systems are capable of measuring temperature, pressure, and species concentrations at kHz rates along several paths simultaneously by using appropriate fiber splitters without increasing the number of laser sources [4]. In the present investigation, a closed-loop combustion control system which combines a multiplexed diode-laser sensor with a computer-controlled feedback circuit is demonstrated to measure and control the gas temperature and H<sub>2</sub>O mole fraction in the burned gases above a CH<sub>4</sub>-air flame.

## Theory

The theoretical basis for determining gas temperature and species concentration from measured absorption spectra recorded in combustion flows [3] and the spectroscopic parameters of the H<sub>2</sub>O transitions [near 1343 nm ( $\nu_1+\nu_3$  band) and 1392 nm ( $2\nu_1, \nu_1+\nu_3$  bands)] probed [6,7] have been described previously [4,5]. In brief, the transmission of narrow-linewidth radiation at frequency  $\nu$  through a medium of length  $L$  may be described by the Beer-Lambert relation

$$T_\nu = I_\nu / I_0 = \exp(-k_\nu L) \quad (1)$$

where  $T_\nu$  is the transmittance of the medium at frequency  $\nu$ ,  $I_\nu$  is the residual intensity at  $L$ ,  $I_0$  is the incident intensity (at  $\nu$ ), and  $k_\nu$  is the (spectral) absorption coefficient [ $\text{cm}^{-1}$ ]. The ratio of the absorption coefficients at two absorption peaks,  $R_{\text{peak}}$ , is a function of the relative populations in the participating ro-vibronic states and hence can be a strong function of temperature. Thus, in

presented at the 1996 Combustion Symposium, Italy

general, the gas temperature may be determined from measurements of  $R_{\text{peak}}$ . Mole fraction (or concentration) may be determined from the measured absorption at a particular wavelength using the known line strength and the measured temperature [2-5].

## Experimental Method

Figure 1 shows the general arrangement of the combustion-control experiment. Details of the laser system and the operating conditions employed to control the lasers have been described previously [4,5]. The system includes two independently operated distributed feedback (InGaAsP) semiconductor diode lasers that (for the scanned-wavelength method) were tuned at a 1-kHz repetition rate over the desired transitions by ramp-modulating the individual injection currents to yield single-sweep, spectrally-resolved absorption records every millisecond. In the fixed-wavelength strategy, the laser wavelengths, monitored with a wavemeter (Burleigh), were maintained (by varying the injection current) near the value which yielded maximum absorption. The individual laser outputs were combined into a single path using appropriate single-mode fiber splitters and couplers. The multiplexed, or multi-wavelength, beam was directed through the flowfield using a gradient index of refraction (GRIN) lens fused to the end of the fiber. The transmitted beam was coupled into a 100- $\mu\text{m}$  (core) diameter (multi-mode) fiber with a 7-mm diameter fused GRIN lens. The larger diameter receiving lens and optical fiber were used to maximize coupling efficiency and minimize effects of beam deflection caused by density (and thus refractive index) gradients in the probed region. The transmitted multi-wavelength light was de-multiplexed (spectrally separated) into the constituent laser wavelengths by directing the beam at a non-normal incidence angle onto a diffraction grating. The beams were diffracted at angles specific to each wavelength and subsequently monitored with InGaAs photodiodes (200-

presented at the 1996 Combustion Symposium, Italy

kHz bandwidth). The detector voltages were digitized by a 12-bit (Nicolet) oscilloscope and transferred via GPIB to a Pentium-based (90-MHz) personal computer.

The system was used to record H<sub>2</sub>O absorption spectra through the product gases of a CH<sub>4</sub>-air diffusion flame generated by a Hencken burner. The burner, shown schematically in Fig. 2, consists of a square array (7-cm diagonal) of diffusion flamelets sustained by a matrix of 0.5-mm internal diameter, 16.7-mm long stainless steel needle tubes that carry fuel (CH<sub>4</sub>) from a reservoir fed by a circular annulus. At the top of the burner, the fuel exits the tubes and mixes with streams of co-flowing air to yield ≈460 diffusion flamelets. For the typical operating conditions (CH<sub>4</sub> flow rate ≈ 4 l/min, CH<sub>4</sub> velocity ≈ 40 cm/s in the tubes; air flow rate ≈ 50 l/min, air velocity in the flow straightener ≈ 120 cm/s), the flow was laminar ( $Re_p < 100$ ) and the tips of the flamelets were typically less than 3 mm above the burner surface.

The flame temperature was varied by maintaining a constant air flow rate and adjusting the fuel flow rate, and thus the equivalence ratio, using a proportional, direct-acting, voltage-controlled, solenoid valve. The gas temperature was measured 6 mm above the burner surface using a type-S (platinum-platinum/10% rhodium) thermocouple (130 μm or 5-mil, bare, corrected for radiation effects) as a function of the flow controller input voltage. For the given air flow rate (50 l/min), the flow-controller voltage variation of 2.61-2.81 V yielded an essentially linear variation (to within 1%) in temperature over the range 1810-2200 K, demonstrating the ability to control the gas temperature by changing the CH<sub>4</sub> flow rate. The inverse slope of the variation of temperature with controller voltage, 0.5 mV/K, was used as the proportional gain factor (G) for the feedback control system.

Figure 3 illustrates the strategy for closed-loop control of the gas temperature in the probed region. The initial operating conditions in the burner ( $T_{\text{initial}} \approx 2050$  K) were established by

presented at the 1996 Combustion Symposium, Italy

supplying a 2.74-volt bias to the  $\text{CH}_4$  flow controller, which yielded a  $\text{CH}_4$  flow rate of approximately 4 l/min while maintaining the air flow rate near 50 l/min. A flow controller voltage of 2.79 volts corresponds to an equivalence ratio = 1. The error signal for the control algorithm was proportional to the difference between the value of temperature determined from the peak absorption ratio, averaged exponentially with previous values, and the desired set point value ( $T_{\text{desired}}$ ). The feedback control signal  $V_{\text{control}}$ , the product of the temperature difference ( $T - T_{\text{desired}}$ ) and the gain factor  $G$ , was added to the bias voltage of the flow controller to effectively adjust the gas temperature to the desired value.

## Data Analysis

Figure 4 presents typical single-sweep (raw data) transmission signals obtained simultaneously by tuning two lasers independently at a 1-kHz rate across the selected  $\text{H}_2\text{O}$  absorption features over a 7-cm long path through the  $\text{CH}_4$ -air flame. The peak absorption coefficient for each feature was determined from (the maximum value of) the negative logarithm of the transmitted intensity normalized by the unattenuated laser intensity [3-5]. The gas temperature was determined from the ratio of the peak absorption coefficients ( $R_{\text{peak}}$ ).

To illustrate the sensitivity of the measurement technique, Fig. 5 plots calculated values of  $R_{\text{peak}}$  as a function of temperature for values of total pressure ( $P$ ) in the range 0.8-1.2 atm for a constant  $\text{H}_2\text{O}$  mole fraction ( $X_{\text{H}_2\text{O}} = 0.18$ ). A 20% change in  $P$  produces a 2% change in the calculated gas temperature. Furthermore, variations in  $\text{H}_2\text{O}$  mole fraction, which lead to slight change in the respective absorption coefficients of the probed transitions, result in a negligible change (<0.5%) in the inferred temperature. Thus, for the present flowfield conditions, a reliable determination of  $R_{\text{peak}}$  yields an accurate determination of  $T$ .

presented at the 1996 Combustion Symposium, Italy

Measurements were recorded 6 mm above the flame while modulating the fuel flow rate sinusoidally at various frequencies to demonstrate the capability of the system to measure temperature fluctuations and discriminate between temperature, pressure, and H<sub>2</sub>O mole fraction changes in the flowfield. Figure 6 illustrates various power spectra, the squared Fourier transform of the time-dependent signal, obtained by applying a 2.5-Hz, 0.15-V (peak-to-peak) modulation to the 2.71-V bias voltage on the fuel flow controller. Figures 6(a) and 6(b) were calculated from the measured transmission intensities with the laser tuned to the peak-absorption wavelength and to a neighboring wavelength without absorption, respectively. Figures 6(c) and 6(d) were calculated from the time-dependent temperatures determined from  $R_{\text{peak}}$  and from a (80  $\mu\text{m}$ , 3-mil) thermocouple, respectively.

Variations in the transmission intensity power spectrum that appear in Fig. 6(a) but not in Fig. 6(c) indicate variations in pressure or H<sub>2</sub>O concentration (for example, the relatively strong variation near 4.6 Hz). The temperature spectra illustrated in Figs. 6(c) and 6(d) have nearly equal peak amplitudes and identical peak frequencies, as expected. The relatively smaller noise present in the trace shown in Fig. 6(d) is due to the significantly smaller bandwidth of the thermocouple ( $\approx 4$  Hz) relative to the multiplexed sensor. Not surprisingly, Fig. 6(b) is effectively frequency independent.

Figure 7 compares values of rms temperature fluctuations,  $T_{\text{rms}}$ , computed from power spectra recorded with the multiplexed sensor and the thermocouple for a range of modulation frequencies (0.1-250 Hz) applied to the fuel flow controller (with the amplitude and bias voltages described in Fig. 6). The values agree to within measurement uncertainty for modulation frequencies below 4 Hz, the approximate (-3 dB) bandwidth of the thermocouple, but differ increasingly as the excitation frequency approaches the natural buoyancy instability near 13 Hz.

presented at the 1996 Combustion Symposium, Italy

The increase in the difference between measured  $T_{\text{rms}}$  values with increasing flow modulation frequency is attributed to the relatively slow thermocouple response, due to the low gas flow velocity ( $Nu_D \approx 2$ ), and the finite thermal mass of the bead (diameter = 160  $\mu\text{m}$ ). In contrast, the temporal response of the multiplexed sensor (using the fixed-wavelength technique) is effectively limited by the detection electronics (200-kHz detector bandwidth, for the present work).

As a further test of the sensor, the gas temperature above the flame was increased rapidly by supplying a voltage step (0.16 V) to the  $\text{CH}_4$  flow controller to increase the equivalence ratio towards stoichiometric. Figure 8 illustrates the resulting temperature variation in the post-flame gases 6 mm above the burner measured using the multiplexed sensor (scanned-wavelength technique) and two different thermocouples (3 mil, 5 mil) corrected for radiation effects. The measurements are in excellent agreement prior to the applied step (near 1825 K). After the step, the temperatures recorded by the multiplexed sensor (at a rate of 1 measurement every 2 ms) rise to within 37% of the final steady-state value of  $\approx 2150$  K in  $\approx 18$  ms. Note that the oscillatory overshoot has a significant 12-Hz component apparently due to a natural instability of the flame excited by the step change in the fuel flow rate. The finite response time of the burner is due predominantly to the gas residence time in the volume from the flow controller to the probed region.

Figure 9 demonstrates the capability of the system to respond to programmed changes in the desired set point temperature,  $T_{\text{desired}}$ . Figure 9(a) illustrates a given time-dependent schedule of  $T_{\text{desired}}$ . Figure 9(b) shows a step change in the flow controller bias voltage which results in a corresponding change in the fuel flow rate and represents an unwanted perturbation in the gas temperature which the control system is designed to minimize. Figure 9(c) compares the

presented at the 1996 Combustion Symposium, Italy

temperatures measured with the multiplexed sensor (dots) for various desired values (dashes) and includes the effects of the applied step perturbation in Fig. 9(b). Figure 9(d) plots the percentage temperature variation  $(T - T_{\text{desired}})/T_{\text{desired}} \times 100\%$ . The maximum transient variation between the measured temperature and desired value, which occurred after a step perturbation in the fuel flow rate (at  $t = 60$  sec and  $t = 80$  sec), was 6%. The standard deviation in the percentage temperature variation was less than 1% for the entire measurement interval.

The  $(1/e)$  response time of the closed-loop control system, the time necessary for the mean measured gas temperature to reach a value within 37% of the normalized temperature differential  $(T - T_{\text{desired}})/T_{\text{desired}}$  induced by an applied step change, was about 1 sec and includes the gas flow residence time from the flow controller through the burner to the probed region (20 ms); the scan time of the lasers (1 ms); the digital transfer time through GPIB (60 ms); the computational time for data analysis and determination of feedback control signal (0.3 ms); actuator response time (3 ms); and the time required to reset the scope trigger (40 ms). A significant reduction in the response time may be achieved by using an improved data transfer procedure to the computer, reducing the laser scan time, implementing a fixed-frequency absorption measurement strategy [3], or, most importantly, decreasing the gas volume from the flow controller to the burner surface. In addition, actuation strategies that do not rely on the gas flow rate through the supply line to or through the burner reservoir (e.g., direct acoustic modulation) may be applied to reduce the phase lag between the control signal to the actuator and the resultant gas temperature change.

Figure 10 compares values of  $\text{H}_2\text{O}$  mole fraction measured ( $X_{\text{meas}}$ ) with the multiplexed sensor (dots) for the burner operating conditions described in the top frame with estimated chemical-equilibrium values (dashes) calculated ( $X_{\text{calc}}$ ) at the desired temperatures. The apparent error in the  $X_{\text{meas}}$  values ( $\approx 9\text{-}10\%$ ) is primarily due to the uncertainty and fluctuations in the  $\text{CH}_4$

presented at the 1996 Combustion Symposium, Italy

flow rate through the solenoid valve (5%) and temperature fluctuations in the flowfield (4-5%). Thus measurements of species mole fraction (concentration) could also be used in a feedback system for process control.

The results of recent improvements in the closed-loop control system to suppress the effects of a step change (perturbation) in the fuel flow rate is shown in Fig. 11. This system, which incorporates recent advances in computer-based data-acquisition hardware, measures a temperature and computes an appropriate control signal every 2 ms, fifty times faster than the system demonstrated in Fig. 9. An A/D scopecard (Gage Compuscope 512), located inside the computer, replaced the GPIB-controlled oscilloscope and reduced the data transfer time from 60 to 0.7 ms. The top frame illustrates both the closed-loop performance (solid) of the control system and the open-loop response (dash) of the burner to the applied change in fuel flow rate. The bottom frame plots the percent deviation from the desired temperature (1825 K). The maximum variation between the measured temperature and the desired value, which occurred immediately after the step change in the fuel flow rate, was 10%. The standard deviation in the percentage temperature variation was less than 1% for the total measurement interval. The 1/e response time of the closed-loop control system was  $\approx 10$  ms. The settling time, the time necessary for the relative temperature differential to decrease below 3% after the step, was  $\approx 30$  ms. Additional improvements in hardware which incorporate new acquisition and processing strategies should enable closed-loop control at the tuning rate of the lasers (1-10 kHz).

### **Application considerations**

The Hencken burner used in these experiments produces a uniform, constant-pressure flowfield and thus serves as an attractive testbed for the initial development of a combustion-

presented at the 1996 Combustion Symposium, Italy

control system based on diode-laser absorption measurements. Current efforts are focused on reducing effects due to flowfield gradients and particulates which influence the interpretation and applicability of the measurements in realistic systems. Since absorption techniques yield line-of-sight measurements, the measured parameters (gas temperature, mole fraction) represent path-averaged values over the probed region. Careful selection of the absorption transitions monitored can be used to mitigate the influence of temperature and density non-uniformities in boundary layers and nonuniform combustion regions [3]. In addition, effects due to particulates or variations in window transmission with time are minimized by tuning the laser to a nearby wavelength (with no absorption transition) periodically (at a rate faster than the scattering timescales) to determine the reference intensity  $I_0$ . Among the most difficult challenges facing implementation of the technique in large-scale industrial facilities will be the strong refractive index gradients caused along the probed path that can deflect the beam, vary the collection efficiency of laser light into the receiving fiber, and thus affect the transmitted beam intensity on the photodetector surface. In such cases, it will be necessary to modify the optical train to accommodate changes in the beam location and orientation without perturbing the intensity reaching the detector.

## Conclusions

A closed-loop feedback system which incorporates a multiplexed diode-laser sensor was used to monitor and control the gas temperature along a single path in the burned gases above a  $\text{CH}_4$ -air flame. Externally induced fluctuations in the gas temperature (up to frequencies of 250 Hz) were recorded to demonstrate the rapid measurement capabilities of the sensor. The control system minimized the difference between the measured gas temperature and a desired value by actively controlling the methane flow rate to the burner using a voltage-controlled solenoid

presented at the 1996 Combustion Symposium, Italy

valve. The system was capable of controlling the gas temperature in the probed region to within 1% (standard deviation) of the desired value for various set points in the range 1800-2100 K. The frequency response of the control system, limited primarily by the gas residence time in the burner, may be improved by reducing the burner reservoir volume to decrease the phase lag between the control signal and the resultant temperature change, increasing the digital transfer rate to the computer to increase the data acquisition rate, or using fixed-frequency absorption techniques to decrease measurement time. Multiplexed diode-laser sensing holds promise for improved monitoring and control of combustion and other high temperature process streams, particularly for applications that require remote and non-intrusive monitoring.

### **Acknowledgments**

This research was supported by the Strategic Environmental Research and Development Program, with K. Schadow as Technical Monitor, and the U.S. Air Force Office of Scientific Research, Aerospace Sciences Directorate, with J. Tishkoff as Technical Monitor.

presented at the 1996 Combustion Symposium, Italy

## References

1. L.C. Philippe and R.K. Hanson, *Appl. Opt.* 32, 6090-6103 (1993).
2. M.P. Arroyo, T.P. Birbeck, D.S. Baer, and R.K. Hanson, *Opt. Lett.* 19, 1091-1093 (1994).
3. D.S. Baer, V. Nagali, E.R. Furlong, R.K. Hanson, M.E. Newfield, *AIAA Journal* 34, 489-493 (1996).
4. V. Nagali, E.R. Furlong, S.I. Chou, R.M. Mihalcea, D.S. Baer, R.K. Hanson, *Proceedings of the 31st AIAA Joint Propulsion Conference*, AIAA-95-2684 (AIAA, NY 1995).
5. D.S. Baer, R.K. Hanson, M.E. Newfield, N.K. Gopaul, *Opt. Lett.* 19, 1900-1902 (1994).
6. R. A. Toth, *Appl. Opt.* 33, 4851-4867 (1994).
7. L.S. Rothman, et al., *JQSRT*, 48, 469-507 (1992).

## Figure captions

Fig. 1 Schematic diagram of the combustion-control experimental arrangement.

Fig. 2 Schematic diagram of the Hencken burner used to sustain a square array of non-premixed CH<sub>4</sub>-air flamelets.

Fig. 3 Block diagram illustrating the strategy used for closed-loop control of the temperature. The system compares the measured temperature,  $T$ , with a desired value,  $T_{\text{desired}}$ , and introduces a control voltage,  $V_{\text{control}}$ , to the fuel flow controller.

Fig. 4 Typical single-sweep (raw data) transmission signals obtained simultaneously by tuning two diode lasers at a 1-kHz rate across H<sub>2</sub>O absorption features near 1343 nm (top frame) and 1392 nm (bottom frame) over a 7-cm long path through the burned region above a CH<sub>4</sub>-air flame.

Fig. 5 The ratio of peak absorption coefficients,  $R_{\text{peak}}$ , calculated as a function of temperature for various values of total pressure for the probed H<sub>2</sub>O transitions (for  $X_{\text{H}_2\text{O}} = 0.18$ ).

Fig. 6 Normalized power spectra for (a) transmission at peak of absorption feature (1343 nm), (b) unattenuated transmission (laser tuned off line), (c) the measured temperature, and (d) the temperature measured with an 80- $\mu\text{m}$  (3-mil) thermocouple. The spectra were recorded while sinusoidally modulating the bias voltage to the flow controller at 2.5 Hz.

Fig. 7 Temperature (rms) fluctuations determined from the power spectrum at various externally induced modulation frequencies. Measurements from the multiplexed sensor ( $\bullet$ ) agree with those from an 80- $\mu\text{m}$  (3-mil) thermocouple ( $\blacktriangle$ ) at low frequencies. As the modulation frequency increases, the thermocouple response (- -) decays exponentially.

Fig. 8 Comparison of temperatures measured in the burned region above a CH<sub>4</sub>-air flame due to an applied step change in the fuel flow rate using the multiplexed sensor and thermocouples.

Fig. 9 Measured temperatures in the burned region above the CH<sub>4</sub>-air flame illustrating the capability of the closed-loop control system to maintain the desired set-point temperature and compensate for perturbations in the fuel flow rate. (a) time-dependent set-point temperature,  $T_{\text{desired}}$ ; (b) step change in the flow controller bias voltage; (c) measured temperatures; and (d) percentage variation between the measured and desired values.

Fig. 10 Comparison of H<sub>2</sub>O mole fractions ( $X_{\text{meas}}$ ) determined (simultaneously with temperature) from peak absorption coefficient measurements ( $\bullet$ ) using the multiplexed sensor with calculated ( $X_{\text{calc}}$ ) chemical-equilibrium values (- -) for conditions described in Fig. 9.

Fig. 11 Closed-loop performance using an advanced data acquisition system. The top frame includes a typical open-loop (no feedback) response for comparison. The bottom frame plots the percentage temperature variation ( $T_{\text{desired}} = 1825$  K).

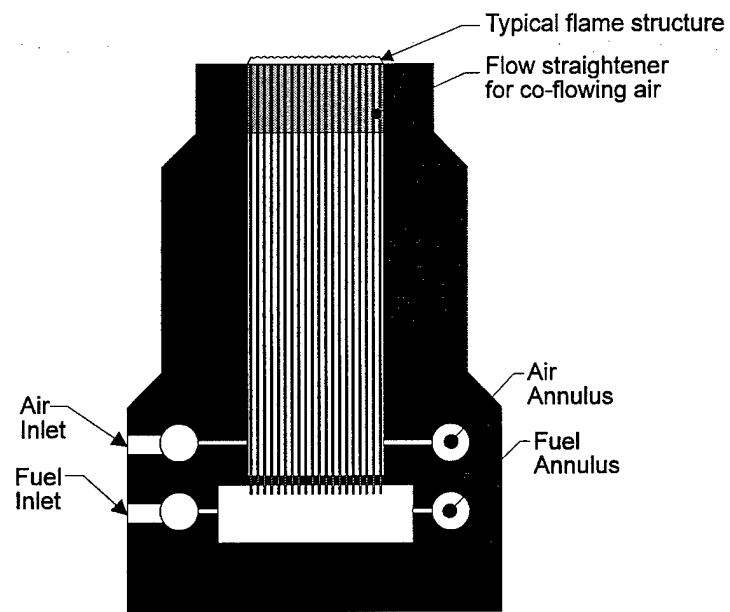

Fig. 2

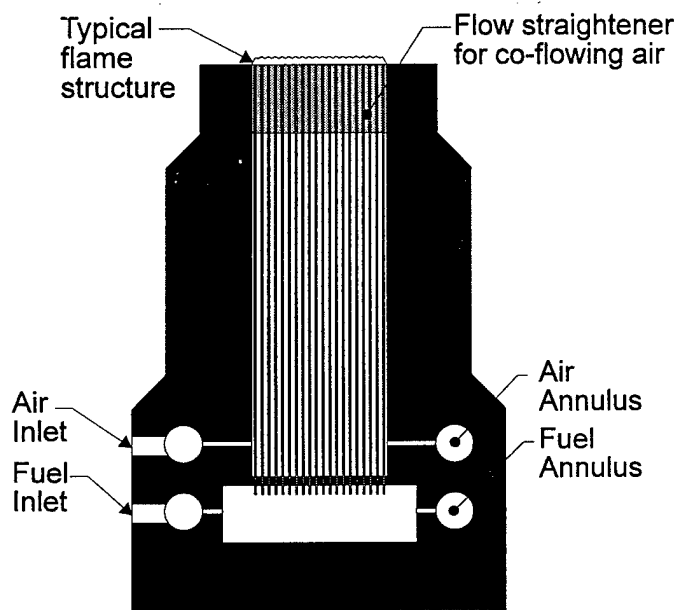

Fig. 2

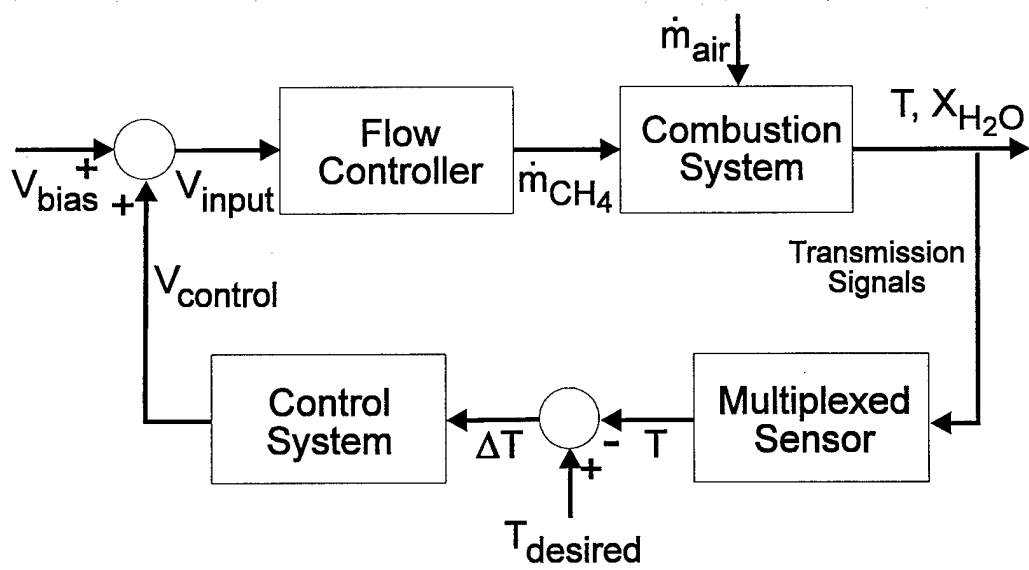

Fig. 3

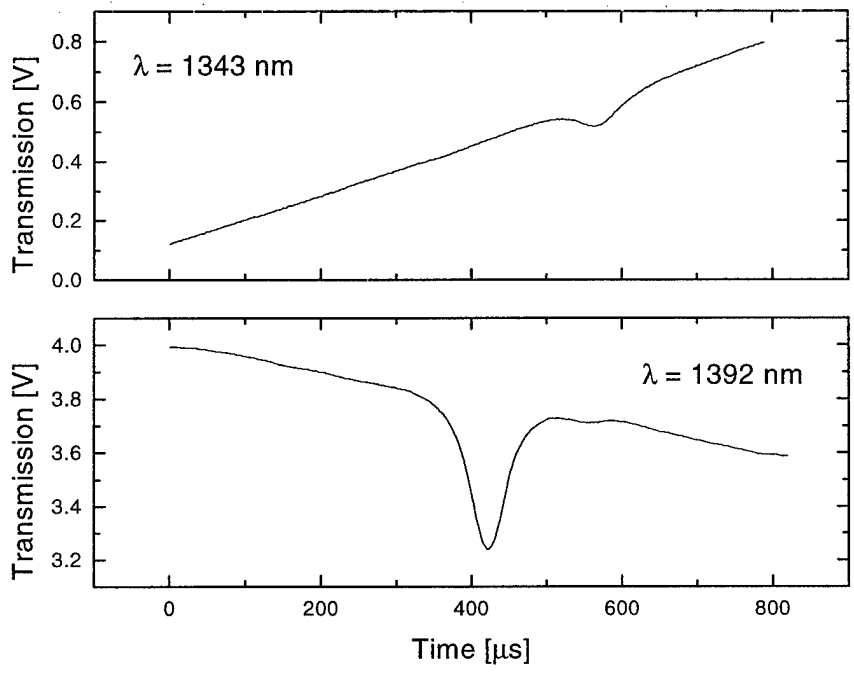

Fig. 4

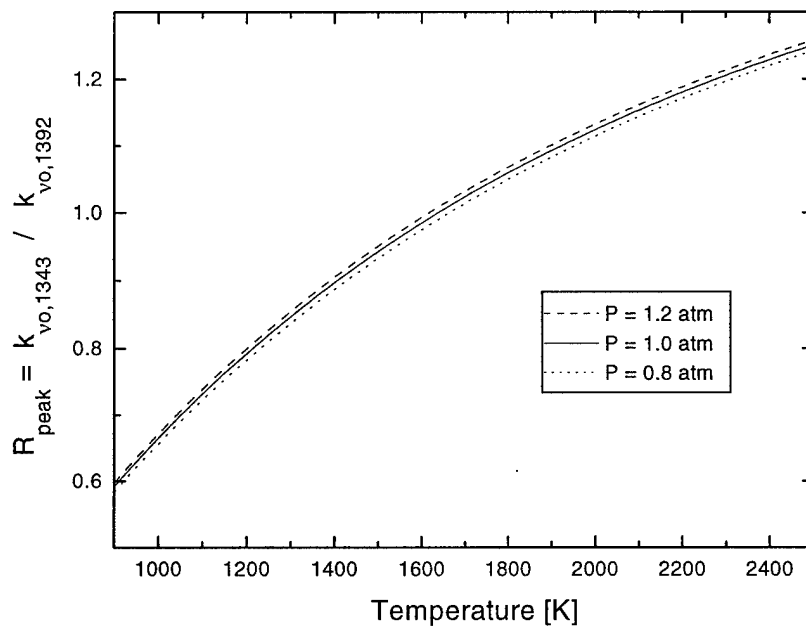

Fig. 5

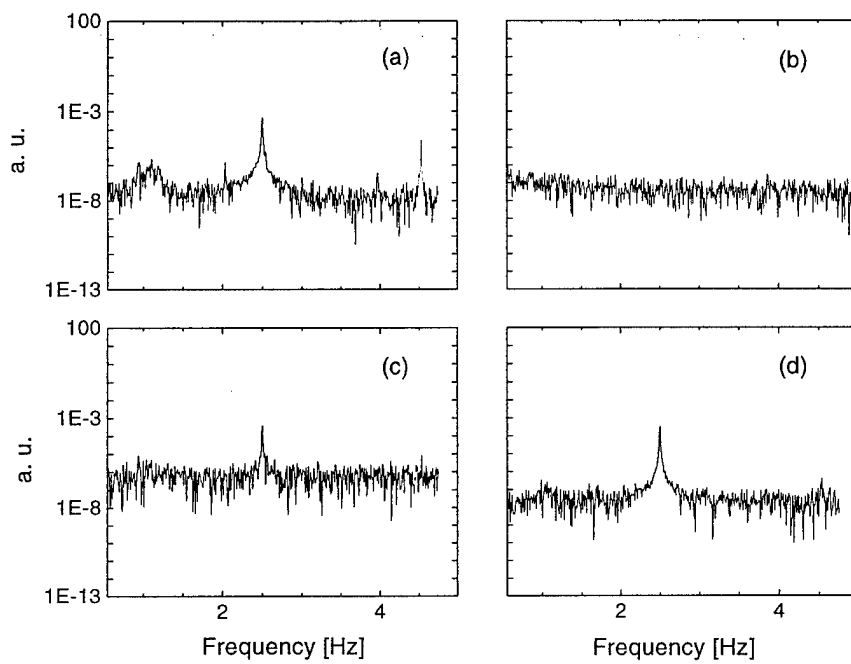

Fig. 6

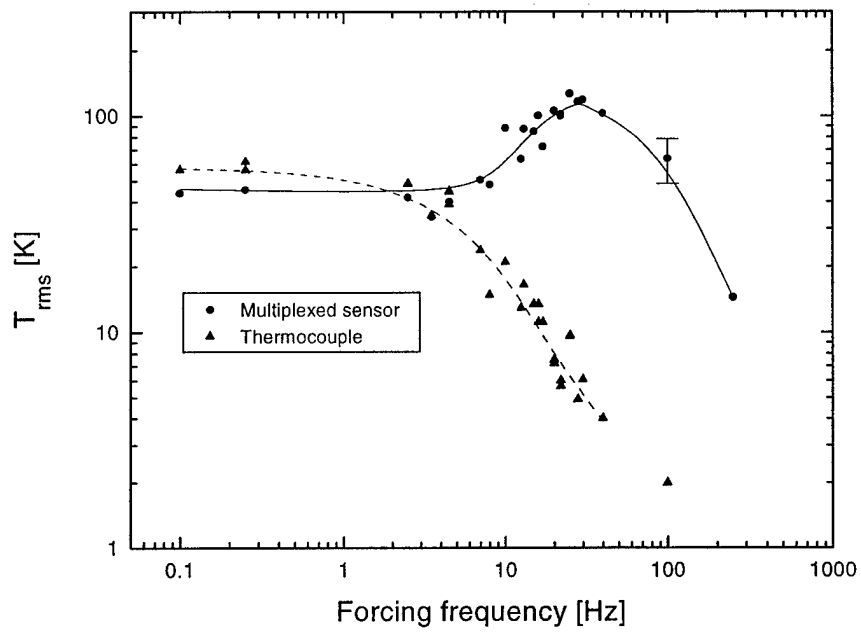

Fig. 7

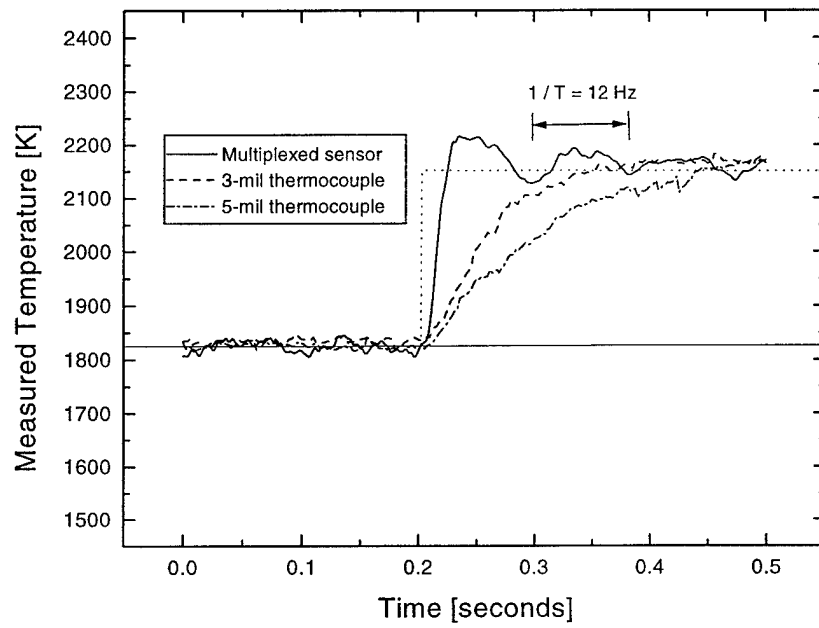

Fig. 8

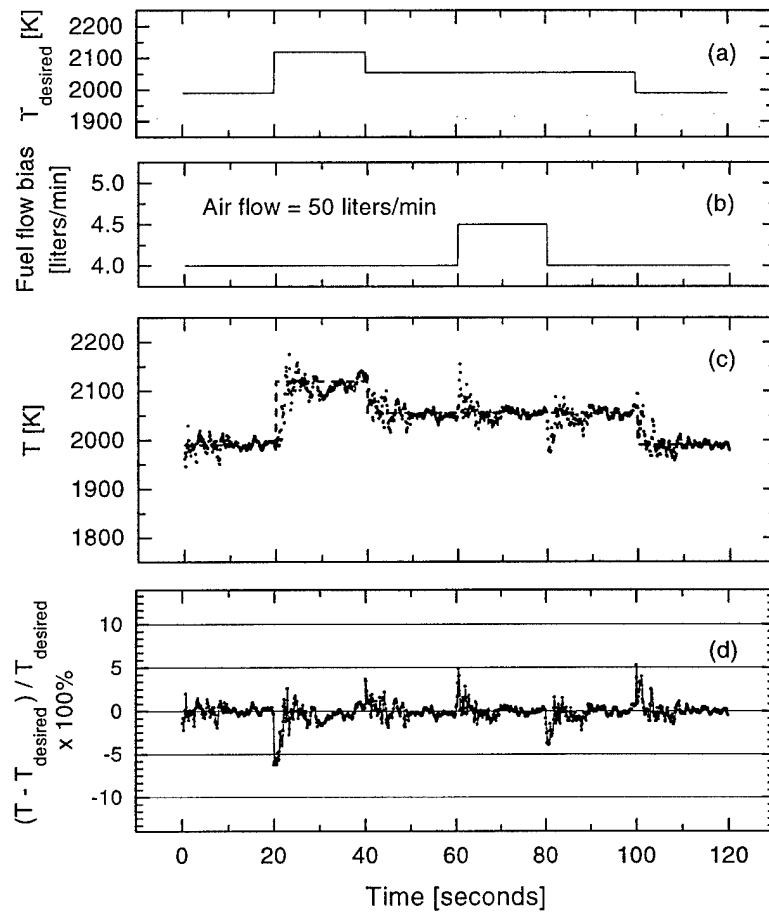

Fig. 9

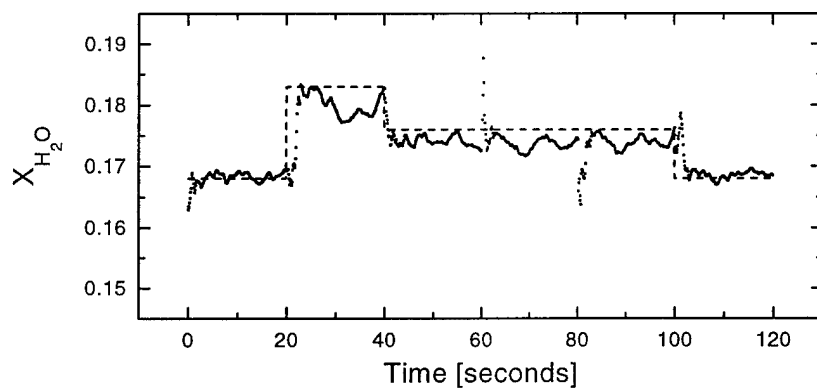

Fig. 10

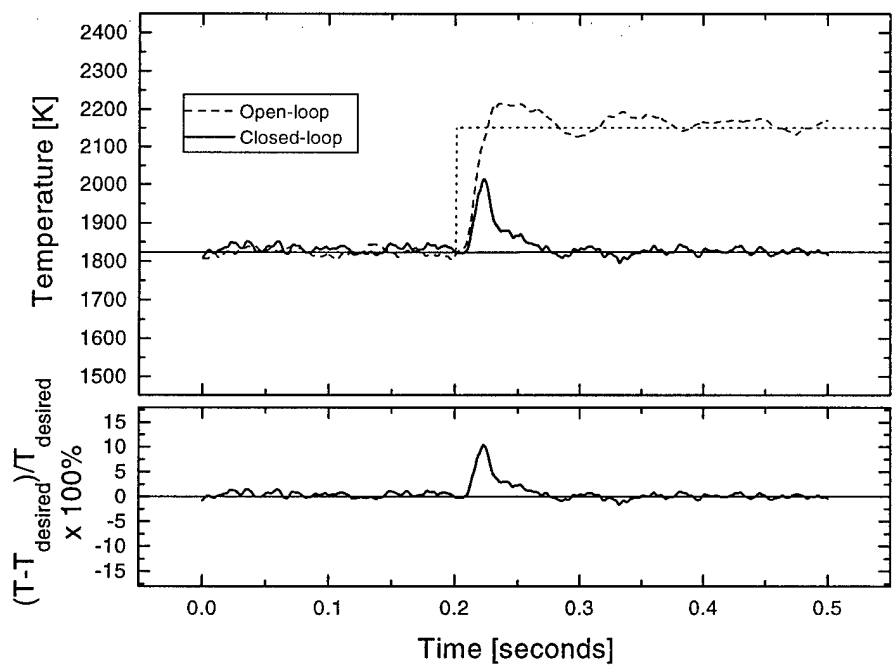

Fig. 11