

# LOAN DOCUMENT

PHOTOGRAPH THIS SHEET



INVENTORY

DTIC ACCESSION NUMBER

LEVEL

*Manufacturing Methods + Technology, Program Plan*  
DOCUMENT IDENTIFICATION  
*Sep 80*

**DISTRIBUTION STATEMENT A**  
Approved for Public Release  
Distribution Unlimited

DISTRIBUTION STATEMENT

ACCESSION FOR	
NTIS	GRAM <input type="checkbox"/>
DTIC	TRAC <input type="checkbox"/>
UNANNOUNCED	<input type="checkbox"/>
JUSTIFICATION	<input type="checkbox"/>
BY	
DISTRIBUTION/	
AVAILABILITY CODES	
DISTRIBUTION	AVAILABILITY AND/OR SPECIAL
A-1	

DISTRIBUTION STAMP

--

DATE ACCESSIONED

--

DATE RETURNED

--

REGISTERED OR CERTIFIED NUMBER

19990514 006

DATE RECEIVED IN DTIC

PHOTOGRAPH THIS SHEET AND RETURN TO DTIC-FDAC

H  
A  
N  
D  
L  
E  
  
W  
I  
T  
H  
  
C  
A  
R  
E

RIA-80-U1058

**U S ARMY**

**RIEL DEVELOPMENT AND READINESS COMMAND**

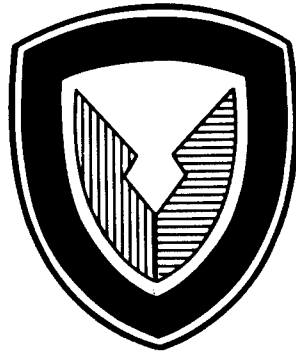

**TECHNICAL  
LIBRARY**

# **MANUFACTURING METHODS & TECHNOLOGY**

**PROGRAM PLAN**

**CY 1980**

**DISTRIBUTION UNLIMITED  
DOCUMENT FOR PUBLIC RELEASE**

---

**PREPARED BY**

**SEPTEMBER 1980**

**MANUFACTURING TECHNOLOGY DIVISION  
U S ARMY INDUSTRIAL BASE ENGINEERING ACTIVITY  
ROCK ISLAND, ILLINOIS 61299**

UNCLASSIFIED

SECURITY CLASSIFICATION OF THIS PAGE (When Data Entered)

REPORT DOCUMENTATION PAGE		READ INSTRUCTIONS BEFORE COMPLETING FORM
1. REPORT NUMBER	2. GOVT ACCESSION NO.	3. RECIPIENT'S CATALOG NUMBER NONE
4. TITLE (and Subtitle) MANUFACTURING METHODS AND TECHNOLOGY PROGRAM PLAN		5. TYPE OF REPORT & PERIOD COVERED ANNUAL
		6. PERFORMING ORG. REPORT NUMBER NONE
7. AUTHOR(s) John Petrone		8. CONTRACT OR GRANT NUMBER(s) N/A
9. PERFORMING ORGANIZATION NAME AND ADDRESS US ARMY INDUSTRIAL BASE ENGINEERING ACTIVITY ATTN: DRXIB-MT ROCK ISLAND, IL 61299		10. PROGRAM ELEMENT, PROJECT, TASK AREA & WORK UNIT NUMBERS N/A
11. CONTROLLING OFFICE NAME AND ADDRESS US ARMY INDUSTRIAL BASE ENGINEERING ACTIVITY ATTN: DRXIB-MT ROCK ISLAND, IL 61299		12. REPORT DATE September, 1980
14. MONITORING AGENCY NAME & ADDRESS (if different from Controlling Office) US ARMY MATERIAL DEVELOPMENT & READINESS COMMAND ATTN: DRCMT 5001 Eisenhower Ave. Alexandria, VA 22333		13. NUMBER OF PAGES 238
		15. SECURITY CLASS. (of this report) UNCLASSIFIED
16. DISTRIBUTION STATEMENT (of this Report) DISTRIBUTION UNLIMITED		15a. DECLASSIFICATION/DOWNGRADING SCHEDULE N/A
17. DISTRIBUTION STATEMENT (of the abstract entered in Block 20, if different from Report) DISTRIBUTION UNLIMITED		
18. SUPPLEMENTARY NOTES N/A		
19. KEY WORDS (Continue on reverse side if necessary and identify by block number) Manufacturing Technology Manufacturing Methods and Technology Program Plan		
20. ABSTRACT (Continue on reverse side if necessary and identify by block number) This document briefly summarizes the technical work being executed or planned in the MMT Program for fiscal years 80 through 84.		

DD FORM 1473  
1 JAN 73

EDITION OF 1 NOV 65 IS OBSOLETE

UNCLASSIFIED

SECURITY CLASSIFICATION OF THIS PAGE (When Data Entered)



DEPARTMENT OF THE ARMY  
HEADQUARTERS US ARMY MATERIEL DEVELOPMENT AND READINESS COMMAND  
5001 EISENHOWER AVE., ALEXANDRIA, VA. 22333

DRCMT

24 SEP 1980

SUBJECT: 1980 DARCOM MMT Program Plan

SEE DISTRIBUTION (Appendix D)

1. Reference draft AR 700-90, Army Industrial Preparedness Program, para 3-8c(2), dated 24 June 1980.
2. The subject document submitted IAW reference 1, describes the DARCOM Manufacturing Methods and Technology (MMT) Program for the period FY 80-84. This plan was compiled by amending the February 1980 data submitted for the Program Objective Memorandum (POM) Support Document. The amendments take into account subsequent programming actions taken since February; namely, FY80 project approvals, FY81 apportionment submissions, and FY82 budget submissions.
3. Because of the dynamic nature of military materiel requirements and the constant changes in technology, the inclusion of a project in this plan is not a guarantee of funding. However, the plan does indicate the current technology needs and interests of the DARCOM community.
4. Additional copies of this document may be obtained by writing the Defense Documentation Center, ATTN: TSR-1, Cameron Station, Alexandria, VA 22314.

1 Incl  
CY1980 DARCOM  
MMT Program Plan

*James W. Carstens*  
for FREDERICK J. MICHEL  
Acting Chief  
Manufacturing Technology

## FORWARD

This document presents information for the DARCOM Manufacturing Methods and Technology (MMT) Program for Fiscal Years 1980-1984. The projects and funding levels for the out-years are for planning purposes only and will change based on technological developments and revisions in program requirements. Since total funding for these planned projects exceeds the projected funds for the Army's MMT Program, some projects will not be funded or may be slipped to later fiscal years. HQ, DARCOM and its major commands and centers have the authority to reprogram funds to projects with higher priority, thereby affording the flexibility to accommodate new opportunities as they arise.

## INDEX

	<u>Page</u>
I. INTRODUCTION -----	1
II. SUMMARY -----	3
III. COMMAND PLANS	
US Army Armament Materiel Readiness Command & US Army Armament Research and Development Command -----	9
Ammunition Program -----	13
Weapons Program -----	63
US Army Aviation Research and Development Command -----	93
US Army Communications Research and Development Command -----	119
US Army Electronics Research and Development Command -----	129
US Army Materials and Mechanics Research Center -----	151
US Army Mobility Equipment Research and Development Command -----	159
US Army Missile Command -----	169
US Army Tank-Automotive Command -----	199
US Army Test and Evaluation Command -----	217
IV. APPENDICES	
Industry Guide -----	A1
MMT Points of Contact -----	B1
IBEA Points of Contact -----	C1
Distribution List for Five Year Plan -----	D1

## INTRODUCTION

### The MMT Program

The Manufacturing Methods and Technology (MMT) Program serves the US Army Materiel Development and Readiness Command (DARCOM) as a bridge between research and development and production. The program's primary aim is to reduce the cost of weapons system acquisition by improving the efficiency of manufacturing processes and by implementing new technology. Although cost reduction is a primary concern, emphasis is also directed towards efforts in reducing air and water pollution, increasing safety, conserving energy, and reducing dependence on critical materials.

The Army's production needs span the full range of modern technology from the high speed production of millions of small arms rounds to the forging of turrets for fifty-ton tanks to the production of integrated circuits. Product testing, material handling, and computer-aided design and manufacturing all fall within the scope of the MMT Program.

### The MMT Program Plan

This document is an attempt to provide within a single source a summary of current and near-term efforts included in the DARCOM MMT Program. Since weapons systems requirements and the technology for these systems are constantly changing, inclusion in the Program Plan is not a guarantee that an individual project will be funded. However, the Plan does serve as an indicator of the areas towards which DARCOM's resources will be directed and the magnitude of the Army's commitment to this program.

### Organization of the MMT Program Plan

The Plan provides a section for each DARCOM element which has projects in the FY 80-84 period. Each section includes a summary of the activity, its responsibilities, and its major MMT thrust areas. Following this summary is a listing of each project proposed by that activity.

Individual project information is presented by the last four digits of the project number and includes the project title, funding, a brief description of the problem addressed by the project and the proposed solution. Projects are grouped according to broad categories and then further subdivided according to component. This arrangement points out major areas of emphasis and aids the identification of possible duplication of effort.

## Industry Guide

An Industry Guide (Appendix A) has been included to aid in the use of the plan. The section will help clarify the interrelationships between the appropriations, commands, and personnel involved in the DARCOM MMT Program.

## SUMMARY

SUBMACOM SUBMISSION TO MMT PROGRAM  
BY COMMAND (Thousands of Dollars)

<u>Command</u>	<u>Fiscal Code</u>	<u>Appropriation</u>	<u>FY 80</u>	<u>FY 81</u>	<u>FY 82</u>	<u>FY 83</u>	<u>FY 84</u>
ARRADCOM/ARRCOM	4250	Ammunition	22109	21440	30127	32393	31577
	3297	Weapons	5948	6280	10234	9054	8620
	5297	Communications/Electronics	30	0	0	0	0
	5397	Other Support	2825	4666	2885	4451	4795
AVRADCOM	1497	Aircraft	8471	10125	13660	12005	13345
CORADCOM	5297	Communications/Electronics	825	3626	3892	3012	3600
ERADCOM	5297	Communications/Electronics	7327	5218	8028	15450	15400
DARCOM/AMMRC	5397	Other Support	5124	5765	5830	5850	5850
MICOM	1497	Aircraft	0	0	0	290	0
	2597	Missiles	6375	14070	14548	14027	14367
	4250	Ammunition	200	440	0	2250	2632
	5297	Communications/Electronics	0	0	0	225	225
	5397	Other Support	747	811	883	800	800
MERADCOM	5397	Other Support	1267	1080	0	1926	1877
	3197	Tracked Combat Vehicles	0	0	834	0	0
TACOM	3197	Tracked Combat Vehicles	3055	5600	12220	18800	17025
	5197	Tactical & Support Vehicles	75	410	967	805	1840
TECOM	5397	Other Support	822	1000	1100	1200	1299

SUBMACOM SUBMISSION TO MMT PROGRAM  
BY APPROPRIATION (Thousands of Dollars)

<u>Appropriation</u>	<u>Fiscal Code</u>	<u>FY 80</u>	<u>FY 81</u>	<u>FY 82</u>	<u>FY 83</u>	<u>FY 84</u>
Aircraft	1497	8471	10125	13660	12295	13345
Missiles	2597	6375	14070	14548	14027	14367
Tracked Combat Vehicles	3197	3055	5600	13054	18800	17025
Weapons and Other Combat Vehicles	3297	5948	6280	10234	9054	8620
Ammunition	4250	22309	21880	30127	34643	34209
Tactical and Support Vehicles	5197	75	410	967	805	1840
Communications/Electronics	5297	8182	8844	11920	18687	19225
Other Support Equipment	5397	10785	13322	10698	14227	14621
TOTALS		65200	80531	105208	122538	123252

ANALYSIS OF PREVIOUS PLANNING DATA

<u>CY of Plan</u>	<u>Period Covered*</u>	<u>Percent of Submission Previously Planned</u>	
		<u>FY 81 Apportionment</u>	<u>FY 82 Budget</u>
1975	FY77 - FY81	15.1%	-----
1976	FY78 - FY82	24.7%	15.3%
1977	FY79 - FY83	34.3%	19.8%
1978	FY80 - FY84	45.2%	31.2%
1979	FY79 - FY83*	67.5%	42.1%

This chart shows the percentage of projects currently in the review cycle which were planned in previous years' long range plans.

\*Starting in 1979, the planning period covered was changed to reflect the more immediate future, rather than the POM years.

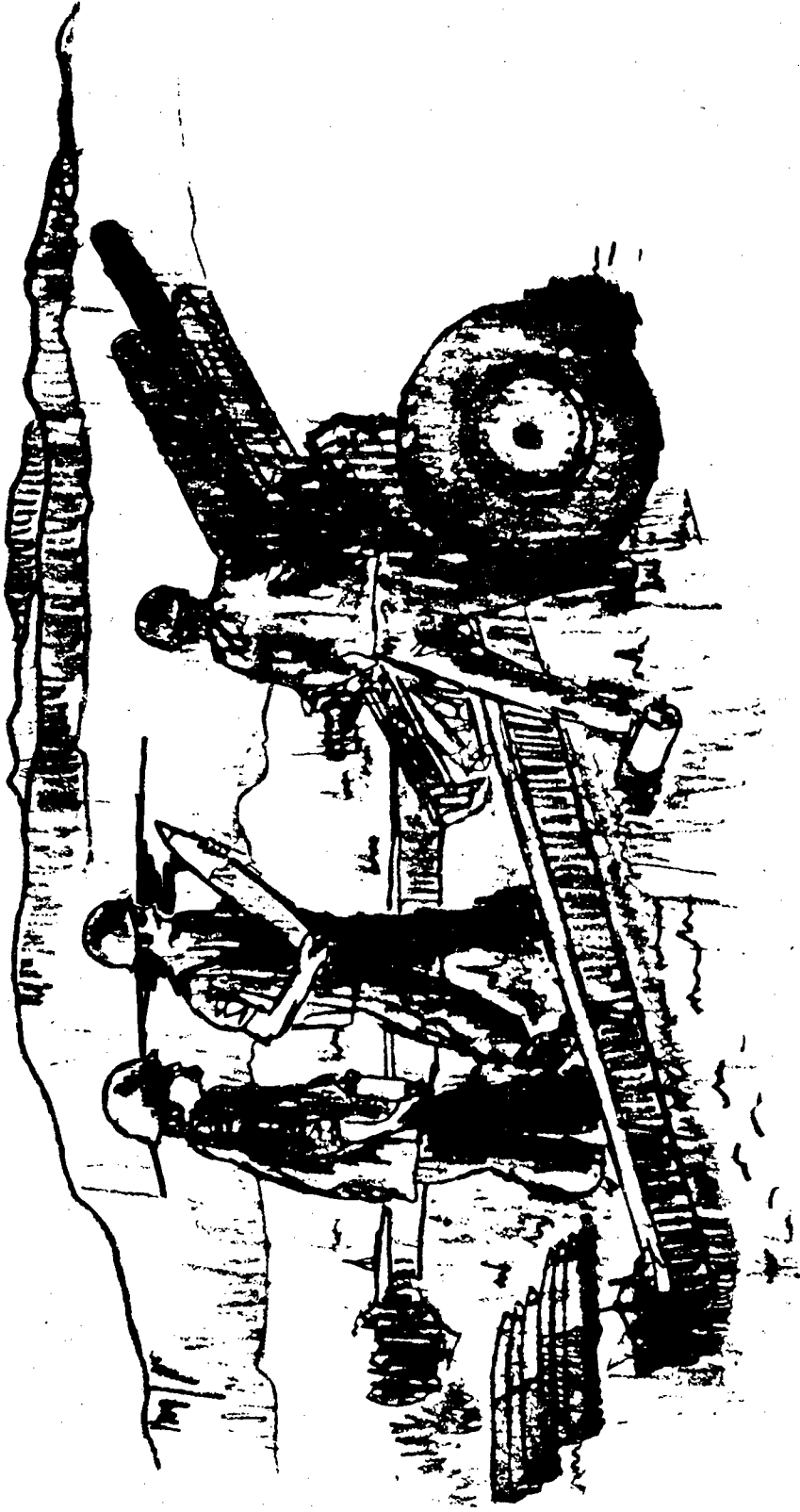

**ARMAMENT R&D COMMAND  
(ARRADCOM)**

**ARMAMENT MATERIEL READINESS COMMAND  
(ARRCOM)**

US ARMY ARMAMENT MATERIEL READINESS COMMAND (ARRCOM)

AND

US ARMY ARMAMENT RESEARCH AND DEVELOPMENT COMMAND (ARRADCOM)

ARRCOM, with headquarters at Rock Island, IL, is responsible for integrated logistics (materiel readiness) management of nuclear and non-nuclear weapons and munitions. This includes follow-on procurement, production, engineering in support of production, industrial management, product assurance, material management, maintenance, value & logistics engineering, international logistics, and transportation and traffic management for assigned armament systems/materiel.

ARRCOM's materiel assignments include artillery, infantry, air defense guns, surface vehicle and aircraft mounted weapons systems, rocket and missile warhead sections, demolition munitions, offensive and defensive chemical materiel and related training equipment, test equipment, and tools. ARRCOM directs operations of four assigned arsenals, three Government-owned, Government-operated ammunition plants, twenty-eight Government-owned, contractor-operated (GOCO) ammunition plants, and an Army ammunition activity. ARRCOM is the DOD Single Manager for Conventional Ammunition. In this capacity, it has responsibility for procurement, production and wholesale management of common-user conventional ammunition for the Army, Navy, and Air Force.

ARRADCOM is responsible for all research development, and life cycle engineering including manufacturing methods and technology engineering of assigned weapon systems. Its mission also includes initial low-rate production for conventional systems and life cycle procurement and production for nuclear munitions. ARRADCOM also executes assigned missions in support of other DOD elements having centralized management responsibility for specific weapons systems or items. In addition to large-caliber, small-caliber, mission support and headquarters staffs at Dover, NJ, command elements include the Chemical Systems Laboratory and the Ballistics Research Laboratory at Aberdeen Proving Ground, MD, and Benet Weapons Laboratory at Water-vliet, NY.

Integrated into ARRCOM's structure is the Office of the Project Manager for the Munitions Production Base Modernization Agency. The PM is responsible for project management of the Munitions Production Base Modernization Program. The PM exercises centralized management authority over the planning, direction, control and execution of the Program at all US Army Ammunition Plants and arsenals. A significant amount of interface between the PM, ARRCOM, ARRADCOM, Air Force and Navy is necessary to assure integration of the MMT Program into related modernization plans.

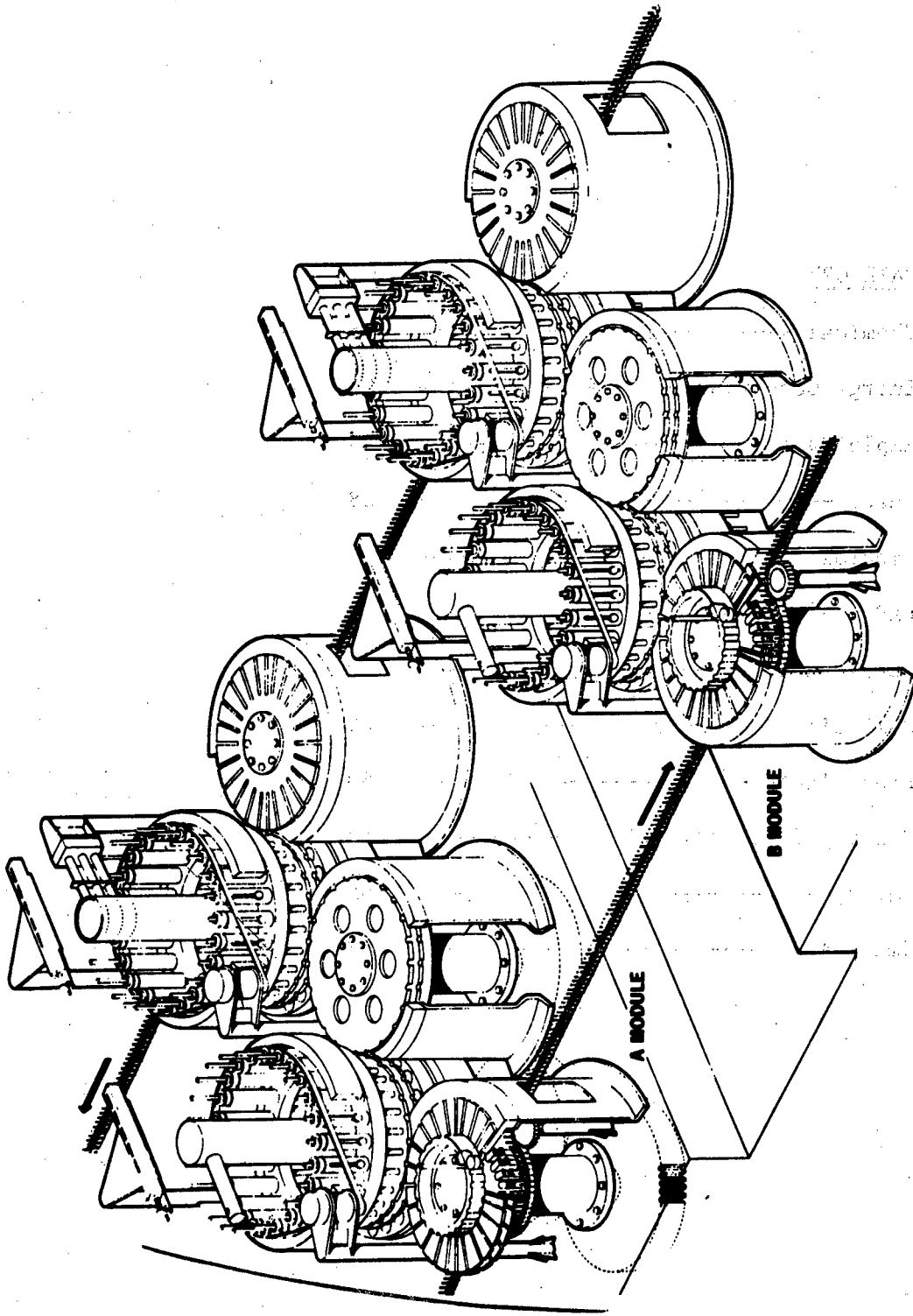

**ARMAMENT R&D COMMAND  
ARMAMENT MATERIEL READINESS COMMAND  
(ARRADCOM, ARRCOM)  
(AMMUNITION)**

<u>CATEGORY</u>	<u>PAGE</u>
Chemical -----	18
Energy Conservation -----	25
Explosives -----	25
Fuzes -----	28
General -----	31
LAP -----	32
Metal Parts -----	39
Pollution Abatement -----	45
Propellants -----	50
Quality Control/Testing -----	53
Safety -----	55
Small Arms -----	58

## AMMUNITION PROGRAM

Bridging the technology gap, particularly in those areas that have no civilian counterpart is a challenging task for the Ammunition MMT Program. In many respects, the Ammunition program presents unique problems which require innovative solutions. For example, material handling, process tools and inspection systems must be computerized to achieve the desired operating economics and to decrease expensive direct labor; however, the new systems must also be capable of economic layaway for periods of ten years or more, a situation that is rare in private industry. Computer manufacturers make provisions for a few months of layaway but not several years. This is the type of situation which the Ammunition MMT program must address.

The primary objective of the munitions manufacturing technology program is to improve existing manufacturing processes, techniques and equipment. The second objective is to bridge the gap between development and full-scale production. The third objective is to solve technological problems identified in the program. Specific functional areas of the munitions program are discussed in the following sections.

The Manufacturing Methods and Technology effort in the Load, Assemble and Pack area is guided by four major program goals; improved economy of operation, improved safety conditions for operating personnel, establishment of a rapid response production capability, and improvements in the quality of the end product produced. All of these goals must be accomplished within the standards and criteria established for pollution abatement and energy conservation.

Recent changes in policy and guidance have required Process Technology Projects to be cost effective within the framework and economics dictated by the Five Year Defense Plan (FYDP). This presents a unique fiscal management challenge in the design and fabrication of equipment and systems required for the loading and assembly of components and end items. The challenge is being met by developing systems with the flexibility to produce many items, establishing an optimum balance between system simplicity and process operational requirements, and providing equipment designs capable of high efficiency operation to achieve cost effective system operations.

Due to the inherently hazardous nature of munitions production, an extensive program has been undertaken to upgrade the safety of explosive preparation equipment, loading equipment, and assembly systems. The MMT program relating to the upgrading of the operational safety of loading lines is a continuation of current efforts. This program will define and investigate specific operational safety hazards, and will develop equipment and systems to reduce operator exposures and risks.

Current planning requires that in the event of mobilization, production facilities be activated within a three month time frame and reach maximum production in four months. This objective requires that equipment design, layaway techniques, and control technology be oriented to achieve the desired quick reaction capability.

Through advances achieved in automated inspection techniques, automated loading systems, and automated assembly systems, the uniformity and quality of the end product produced has been improved. The munitions MMT program includes several projects oriented towards improving quality control and test technology and others for the development of explosive loading and assembly techniques and equipment.

The Metal Parts MMT Program has as its major thrust investigations into optimum manufacturing processes for SAWS (Squad Automatic Weapon System), RAAM, GEMSS and GATOR, the 120mm Tank, and VIPER. Improvements of existing processes involves such investigations as link manufacturing for small caliber ammo, machining brass cartridge cases, 7.62mm bullet manufacturing by roll forming, and presses for mortar ammunition production. Projects are also included for improving maintainability and readiness posture through computer integrated manufacturing, computer-aided modeling of forming operations, and storage techniques for production machinery. Enhancing reliability and quality control efforts include analysis for predicting tool failure, improving projectile surface quality, and processing hi-frag steel.

Primary program emphasis in energetic materials is being placed on development of manufacturing technology for new munition items including: 120mm (XM-1 tank munition); binary round (8", 155mm and Navy Weteye); alternate ICM explosive fills; LOVA propellants; plastic bonded explosives; and insensitive high explosives and propellants. Recent enactment of the Clean Air Act Amendment and Toxic Substances Control Act has resulted in the requirement for continuous MMT effort to meet mandatory compliance dates. Conservation of production base utilities, energy and resources, as well as identification and utilization of alternate energy sources are broad areas of major concern. The development and design of safe, cost-effective production processes are major goals of the munitions MMT program. Weak points in overall base readiness capability and maintainability will be determined and upgraded where feasible. In the supportive technology areas, the primary thrust areas continue to be pollution abatement engineering, energy technology development and explosives and occupational safety.

## ARRADCOM

C O M M A N D F U N D I N G S U M M A R Y  
(THOUSANDS)

CATEGORY -----	FY80 -----	FY81 -----	FY82 -----	FY83 -----	FY84 -----
CHEMICAL	2825	4666	3674	5961	6870
ENERGY CONSERVATION	1234	1207	1919	1756	1750
EXPLOSIVES	1049	904	3326	2764	2038
FUZES	1512	1327	0	3072	1560
GENERAL	4521	3988	3948	516	320
LAP	2834	3279	7289	8152	7800
METAL PARTS	3036	1992	1166	4000	5665
POLLUTION ABATEMENT	1739	2259	4256	1576	1325
PROPELLANTS	2143	3227	2454	3884	2100
QUALITY CONTROL/TESTING	1854	1885	1464	971	1447
SAFETY	1275	1161	1939	1195	840
SMALL ARMS	942	211	1577	2997	4657
TOTAL	24964	26106	33012	36844	36372

\*\*\*\*\*  
\* C A T E G O R Y \*  
\*-----\*  
\*CHEMICAL\*  
\*\*\*\*\*

NMT FIVE YEAR PLAN  
RCS DRCHT 126

FUNDING (\$000)

PRIOR 80 81 82 83 84  
-----

COMPONENT -- DECONTAMINATION

(0913) TITLE - SPIN COATING OF DECON AGENT CONTAINERS. 332

PROBLEM - CURRENT METALLIC DECON AGENT CONTAINERS CORRODE BEFORE THE REQUIRED SHELF LIFE OF THE AGENTS IS REACHED. ALTERNATIVE CONTAINERS ARE NOT AVAILABLE, BUT PLASTIC LINERS HAVE BEEN SHOWN TO EXTEND THE LIFE OF CURRENT CONTAINERS SIGNIFICANTLY.

SOLUTION - ESTABLISH THE SPIN COATING OR ROTATIONAL MOLDING, TECHNIQUE FOR COATING THE INSIDE OF CURRENT METALLIC CONTAINERS WITH CHEMICALLY RESISTANT POLYMERS FOR THE PRODUCTION ENVIRONMENT.

(2950) TITLE - MFG TECH FOR CLOTHING DECONTAMINATION SYSTEM 500 600

PROBLEM - PRODUCTION PROCESS ENGINEERING PROBLEMS ARE BEING IDENTIFIED DURING DEVELOPMENT, UTILIZING PEP FUNDS. PROCESS TECHNOLOGY REQUIRED UNDER PRODUCTION CONDITIONS FOR COMPLEX AREAS MUST BE ACCOMPLISHED TO INSURE ECONOMICAL AND BROAD BASED PRODUCTION

SOLUTION - ESTABLISH MINIMUM PILOT FACILITIES AND PROVE OUT THE MASS PRODUCTION FEASIBILITY OF COMPLEX PROCESSES AND FABRICATION. PROVIDE DESCRIPTION OF MANUFACTURE AND IN-PROCESS TEST TOOLING DESIGN DATA FOR THE PROCESSES AND/OR COMPONENTRY INVOLVED.

(2951) TITLE - MFG TECH FOR INTERIOR SURFACE DECONTAMINATION SYST 750 700

PROBLEM - PROCESS AND METHODS TECHNOLOGY REQUIRED UNDER PRODUCTION CONDITIONS FOR COMPLEX AREAS WILL HAVE TO BE ACCOMPLISHED, AS THE BASIS FOR PRODUCTION LINE DESIGN, TO INSURE ECONOMICAL AND BROAD-BASED PRODUCTION.

SOLUTION - AS A RESULT OF PEP, ESTABLISH MINIMUM PILOT FACILITIES AND PROVE OUT THE MASS PRODUCTION FEASIBILITY OF COMPLEX PROCESSES AND/OR FABRICATION. PROVIDE DESCRIPTION OF MANUFACTURE AND IN-PROCESS TEST TOOLING DESIGN DATA FOR THE PROCESSES.

(2952) TITLE - MFG TECH FOR SPECIAL APPLICATION DECONTAMINATION S 750 700

PROBLEM - PROCESS AND METHOD TECHNOLOGY REQUIRED UNDER PRODUCTION CONDITIONS FOR COMPLEX AREAS WILL HAVE TO BE ACCOMPLISHED, AS THE BASIS FOR PRODUCTION LINE DESIGN, TO INSURE ECONOMICAL AND BROAD BASED PRODUCTION.

SOLUTION - AS A RESULT OF PEP, ESTABLISH MINIMUM PILOT FACILITIES AND PROVE OUT THE MASS PRODUCTION FEASIBILITY OF COMPLEX PROCESSES AND/OR FABRICATION. PROVIDE DESCRIPTION OF MANUFACTURE AND IN-PROCESS TEST TOOLING DESIGN DATA.

COMPONENT -- DECONTAMINATION

(CONTINUED)

(2953) TITLE - MFG TECH FOR RAPID DECONTAMINATION APPARATUS 450

PROBLEM - PRODUCTION PROCESS ENGINEERING PROBLEMS MUST BE IDENTIFIED DURING DEVELOPMENT, UTILIZING PEP FUNDS. PROCESS TECHNOLOGY REQUIRED UNDER PRODUCTION CONDITIONS FOR COMPLEX AREAS WILL HAVE TO BE ACCOMPLISHED TO INSURE ECONOMICAL AND BROAD BASED PRODUCTION

SOLUTION - AS A RESULT OF PEP, ESTABLISH MINIMUM PILOT FACILITIES AND PROVE OUT THE MASS PRODUCTION FEASIBILITY OF COMPLEX PROCESSES AND/OR FABRICATION. PROVIDE DESCRIPTION OF MANUFACTURE AND IN-PROCESS TEST TOOLING DESIGN DATA.

(2954) TITLE - SPIN COAT PROCESS FOR DECON AGENT CONTAINERS 175 315

PROBLEM - DA HAS A CONTINUAL PROBLEM WITH LEAKING DECON AGENT STORAGE CONTAINERS. APPLICATION OF UNIFORM THICKNESS OF EPOXY IS A PROBLEM COMMERCIALY AVAILABLE CONTAINERS LINED WITH A PROTECTIVE EPOXY IS A PROBLEM.

SOLUTION - ESTABLISH A SPIN COATING PROCESS TO COAT DECON AGENT CONTAINERS WITH A PROTECTIVE EPOXY.

COMPONENT -- DETECTION/WARNING

(0904) TITLE - CHEMICAL REMOTE SENSING SYSTEMS 1112 1159 511

PROBLEM - FIRST GENERATION CHEMICAL REMOTE SENSING SYSTEMS HAVE HIGH PRIORITY. THEY REQUIRE COMPLEX, UNIQUE, SOPHISTICATED COMPONENTRY WHICH IS NOT AVAILABLE TO MEET PRODUCTION REQUIREMENTS. COMPONENTS WILL BE HAND FABRICATED FOR INITIAL DEVELOPMENT.

SOLUTION - IN ORDER FOR PRODUCTION TO BEGIN AS SOON AS POSSIBLE IT IS NECESSARY THAT APPROPRIATE MANUFACTURING TECHNOLOGY START BEING DEVELOPED NOW. CONTRACTORS WITH NECESSARY EXPERIENCE WILL BE UTILIZED TO ESTABLISH PROCEDURES, ETC. FOR QUANTITY MANUFACTURING.

(1345) TITLE - FOR BIOLOGICAL WARNING SYSTEM 525 463

PROBLEM - THERE IS NO BIOLOGICAL AGENT DETECTOR MASS PRODUCTION CAPABILITY.

SOLUTION - UTILIZE PEP DATA AND PROVE THE FEASIBILITY OF MASS PRODUCTION WITH A MINIMUM OF SOLE SOURCE COMPONENTS THAT MUST BE ACQUIRED ON A BROAD BASE.

(2957) TITLE - MFG TECH FOR CHL AGENT ALARM, XM22. 403

PROBLEM - PRODUCTION PROCESS ENGINEERING PROBLEMS MUST BE IDENTIFIED DURING DEVELOPMENT, UTILIZING PEP EFFORT AND FUNDS. PROCESS TECHNOLOGY REQUIRED UNDER PRODUCTION CONDITIONS FOR COMPLEX AREAS WILL HAVE TO BE ACCOMPLISHED.

SOLUTION - AS A RESULT OF PEP, ESTABLISH MINIMUM PILOT FACILITIES AND PROVE OUT THE MASS PRODUCTION FEASIBILITY OF COMPLEX PROCESSES AND FABRICATION. PROVIDE DESCRIPTION OF MANUFACTURE AND IN-PROCESS TESTS TOOLING DESIGN DATA.

PRIOR 80 81 82 83 84  
-----

COMPONENT -- DETECTION/WARNING

(CONTINUED)

(2958) TITLE - MFG TLCH FOR REMOTE BIOLOGICAL ALARM

800

PROBLEM - PRODUCTION PROCESS ENGINEERING PROBLEMS MUST BE IDENTIFIED DURING DEVELOPMENT, UTILIZING PEP EFFORT AND FUNDS. PROCESS TECHNOLOGY REQUIRED UNDER PRODUCTION CONDITIONS FOR COMPLEX AREAS WILL HAVE TO BE ACCOMPLISHED.

SOLUTION - AS A RESULT OF PEP, ESTABLISH MINIMUM PILOT FACILITIES AND PROVE OUT THE MASS PRODUCTION FEASIBILITY OF COMPLEX PROCESSES AND/OR FABRICATION. PROVIDE DESCRIPTION OF MANUFACTURE AND IN-PROCESS TEST TOOLING DESIGN DATA.

(2959) TITLE - MFG TECH, AUTOMATIC LIQUID AGENT DETECTOR

500 700

PROBLEM - PRODUCTION PROCESS ENGINEERING PROBLEMS MUST BE IDENTIFIED DURING DEVELOPMENT, UTILIZING PEP FUNDS. THERE IS A NEED FOR A TECHNIQUE TO COAT THE CIRCULAR GROOVED DISC WITH SILVER FLAKE METALLIC PAINT AND STILL OBTAIN THE RESPONSE TIME REQUIRED.

SOLUTION - AS A RESULT OF PEP, ESTABLISH MINIMUM PILOT FACILITIES AND PROVE OUT THE MASS PRODUCTION FEASIBILITY OF COMPLEX PROCESSES AND/OR FABRICATION. PROVIDE DESCRIPTION OF MANUFACTURE AND IN-HOUSE TEST TOOLING DESIGN DATA.

COMPONENT -- FILTERS

(0900) TITLE - AUTOMATED MULTIPLE FILTER LIFE TESTER

252

PROBLEM - THERE IS A LOW TEST RATE CAPACITY AND AN INCREASING VOLUME OF TESTING FOR THE CURRENT FILTER LIFE TEST EQUIPMENT.

SOLUTION - REDUCE MANPOWER NEEDS BY DEVELOPING A MULTIPLE TEST CHAMBER TESTER WHICH WILL PERMIT FOUR ITEMS TO BE TESTED SIMULTANEOUSLY.

(0905) TITLE - MANUFACTURE OF IMPREGNATED CHARCOAL (WHELTERTE)

235 251 485

PROBLEM - ONLY ONE COMPANY (CALGON, INC) SUPPLIES WHELTERIZED CHARCOAL AND CONSIDERS ITS PROCESS PROPRIETARY. THIS MATERIAL IS VITAL FOR NEW PROTECTIVE MASKS. A PROCESS MUST BE DEVELOPED TO DIVERSIFY PRODUCTION BASE AND REDUCE COST THROUGH COMPETITION.

SOLUTION - MMT PROJECT 5 76 1296 DEMONSTRATED THAT, USING DILUTE SOLUTIONS OF IMPREGNANTS AND MULTI-STAGE SOAKING AND DRYING OF CHARCOAL, SEVERAL CHARCOALS SHOWED DRAMATIC PROTECTION IMPROVEMENT. THIS PROJECT WILL USE THESE RESULTS TO ESTABLISH A PROCESS DESIGN

COMPONENT -- FILTERS

(CONTINUED)

(0907) TITLE - DISPOSABLE AGENT SCRUBBER

79

PROBLEM - ALL EFFLUENTS FROM TEST EQUIPMENT MUST BE COMPLETELY SCRUBBED OF ALL TOXIC MATERIALS. FOR HIGH FLOWS THE LIVES OF STANDARD FILTERS ARE TOO SHORT TO BE ECONOMICAL. CHARCOAL SCRUBBERS MUST BE EMPTIED ONCE A DAY WHICH IS A SERIOUS HAZARD TO THE OPERATOR

SOLUTION - THIS PROJECT WILL DEVELOP A DISPOSABLE SCRUBBER WHICH WILL BE ECONOMICAL AT HIGHEST FLOW RATES. THIS SCRUBBER WILL CONSERVE TEST TIME AND ELIMINATE SAFETY HAZARDS. DESIGN WILL BE AS SIMPLE AS POSSIBLE. CONNECTOR WILL BE LEAK PROOF AND RAPIDLY SET UP.

(1296) TITLE - MANUFACTURING TECHNOLOGY OF CB FILTERS

1404 404

PROBLEM - EXISTING FILTER PRODUCTION FACILITIES ARE OBSOLETE, INEFFICIENT AND EXPENSIVE TO OPERATE.

SOLUTION - MODERNIZE, CONSOLIDATE ALL AREAS INTO ONE FACILITY DESIGN. NEW PROCESS EQUIPMENT.

(2955) TITLE - MFG TECH, MASK CANISTERS - IMPACT EXTRUSION

80 280

PROBLEM - THERE ARE LESS EXPENSIVE METHODS AVAILABLE FOR FABRICATION OF MASK FILTER CANISTERS.

SOLUTION - PROVIDE MANUFACTURING TECHNOLOGY TO IMPACT EXTRUDE THE BODY OF MASK FILTER CANISTERS. THEREBY REDUCING THE UNIT COST OF THE ITEM.

COMPONENT -- PROCESSES

(1348) TITLE - SUPER TROPICAL BLEACH

202 922

PROBLEM - THERE IS A MAJOR SHORTFALL BETWEEN THE FY78 REQUIREMENTS FOR THIS ITEM AND THE QUANTITY OF IMPORTED CHLORINATED LIME KNOWN TO BE AVAILIABLE.

SOLUTION - THIS PROJECT WILL PROVIDE THE BASIC DESIGN OF A SUPER TROPICAL BLEACH FACILITY. STUDIES WILL INCLUDE POLLUTION ABATEMENT AND CONTROL EQUIPMENT TO ASSURE COMPLIANCE WITH OSHA AND EPA STANDARDS.

(1703) TITLE - HEXACHLOROETHANE RECOVERY/REPROCESSING EVALUATIONS

300 300

PROBLEM - 3 MILLION LB STOCKPILE OF UNSERVICEABLE MUNITIONS CONTAIN 1.41 MILLION LBS. OF HEX. STOCKPILE WILL GROW BY 565,000 POUNDS PER YEAR. DEMIL/DISPOSAL NECESSARY IF HEX IS NOT RECOVERED.

SOLUTION - EXPLOIT EXISTING TECHNOLOGY TO RECOVER HEX FROM STOCKPILE. RECOVERED HEX WILL PROVIDE 46 PERCENT OF HC REQUIREMENT. PROCESS WILL BE USEFUL IN REPROCESSING SUBGRADE PURCHASES AS WELL.

MMT FIVE YEAR PLAN  
RCS DRCMT 126

FUNDING (\$000)

PRIOR 80 81 82 83 84

COMPONENT -- PROCESSES

(CONTINUED)

(4476) TITLE - MANUFACTURING TECHNIQUES FOR CR (RIOT CONTROL AGENT)

PROBLEM - UK PRODUCTION SOURCE NO LONGER EXISTS. THERE IS NO US SOURCE FOR CR AND NO PRODUCTION TECHNIQUE EXISTS WITHIN THE US.

SOLUTION - PROJ IS TO ESTABLISH US PILOT PLANT CAP F/MFG OF CR. EXISTING GENERIC PILOT PLANT WILL BE AUGMENTED BY REQBD CR PROCESS EQUIP. MFG PROCESS WILL BE FINALIZED, OPERATING PARAMETERS ESTABLISHED, AND A PROOF QTY OF CR PRODUCED.

(4477) TITLE - ESTABLISH FILL/CLOSE TECHNIQUES FOR BIGEYE BOMB (BLU-80)

PROBLEM - AFTER BIGEYE IS STANDARDIZED, IT CANNOT BE PRODUCED UNLESS MANUFACTURING TECHNIQUES FOR FILL, CLOSE AND LAP PROCESSES HAVE BEEN DEVELOPED.

SOLUTION - ESTABLISH TECHNIQUES AND PROCESSES TO PROVIDE DATA REQUIRED FOR DESIGN OF FULL SCALE PRODUCTION FACILITY.

COMPONENT -- PROTECTIVE GEAR

(0909) TITLE - AUTOMATED AGENT PERMEATION TESTER

197

PROBLEM - MMT PROJECT 5 75 1314 DEVELOPED INSTRUMENTATION FOR AN IMPROVED PERMEATION TESTER. HOWEVER BECAUSE OF COST (\$5,000 PER TEST UNIT) AN ANTIQUATED METHOD USING FRUIT FLIES IS STILL USED FOR MOST OF THESE TESTS.

SOLUTION - A SYSTEM WILL BE DEVELOPED TO SEQUENTIALLY SAMPLE DATA FROM 10 TESTS AND FEED IT TO ONE TEST UNIT. SAMPLES OF ONE MINUTE EVERY TEN MINUTES WILL BE SUFFICIENT BECAUSE OF LONG TEST PERIODS (8 HOURS OR MORE). FLOW CONTROLS INCLUDE SOLENOID VALVES.

(0912) TITLE - PRODUCTION PROCESS F/PROTECTIVE MASK CANISTER BODIES

466

PROBLEM - THE CURRENT FIVE-STEP DEEP-DRAW PROCESS IS TIME CONSUMING, THE PROCESS HARDENS THE MATERIAL AND MAKES IT SUBJECT TO CRACKING.

SOLUTION - ESTABLISH A PROCESS WHEREBY THE CANISTERS WILL BE FORMED ON A PROGRESSIVE DIE MACHINE.

(0914) TITLE - AUTOMATIC FINISHING OF MASK COMPONENTS

677

PROBLEM - DURING MASK MOLDING OPERATIONS, AN EXCESS OF MATERIAL (FLASH) REMAINS ON THE MOLDED PARTS.

SOLUTION - DEVELOP TUMBLING IN A CRYOGENIC ENVIRONMENT AS AN AUTOMATED PROCESS TO REMOVE FLASH.

(CONTINUED)

COMPONENT -- PROTECTIVE GEAR

(1335) TITLE - MFG TECH FOR NEW PROTECTIVE MASK

1437 1504 2121

PROBLEM - FABRICATION OF ONE-PIECE PLASTIC MASKS WITH ADEQUATE OPTICAL CHARACTERISTICS IS DIFFICULT. VISION REDUCTION AND DISTORTION ARE CRITICAL.

SOLUTION - DEVELOP MANUFACTURING PROCESS TO ALLEVIATE PRODUCTION PROBLEMS DEFINED BY PEP EFFORT.

(2956) TITLE - MFG TECH FOR AUTOMATED FINISHING OF MASK COMPONENT

250 300

PROBLEM - REMOVAL OF HOLDING FLASH AND CERTAIN FINISHING OPERATIONS OF MASK COMPONENTS ARE TIME CONSUMING AND EXPENSIVE OPERATIONS.

SOLUTION - EVALUATE LATEST TECHNOLOGY AND ESTABLISH STATE-OF-THE-ART METHODS AND PROCESSES TO AUTOMATE FLASH REMOVAL AND FINISHING OF PROTECTIVE MASK COMPONENTS.

COMPONENT -- PYROTECHNICS

(P012) TITLE - ADAPTATION OF SLUGGING TECHNOLOGY TO HC SMOKE AND CS RIOT MU

135 120

PROBLEM - COLORED SMOKE GRENADE SLUGGING CONCEPT IS NOT ADAPTED TO HC AND RIOT MUNITIONS. CURRENT FILL AND PRESS OPERATIONS ARE LABOR INTENSIVE. INDUSTRIAL HYGIENE IS POOR.

SOLUTION - ADAPT SLUGGING TECHNOLOGY TO HC AND RIOT MIXTURES. IMPROVE INDUSTRIAL HYGIENE.

(P013) TITLE - ADAPTATION OF SLUGGING CONCEPT TO 40MM SMOKE MARKER PRODUCTI

280

PROBLEM - SMOKE MARKER MUST BE FILLED TO CLOSE TOLERANCES. CURRENT FILL METHODS NEED IMPROVEMENTS. LABOR COSTS ARE HIGH. MATLS. HANDLING IS LABOR INTENSIVE.

SOLUTION - ADAPT SLUGGING TECHNOLOGY FOR AUTOMATED PRODUCTION. REPLACE MANUAL MATL. HANDLING WITH MECHANICAL SYSTEMS.

(P016) TITLE - SIMULATION OF PBA PYROTECHNIC PRODUCTION LINES

100

PROBLEM - MULTI-PURPOSE LINES. SHORT DURATION PRODUCTION RUNS.

SOLUTION - PROVIDE SIMULATION SOFTWARE. MONITOR PRODUCTION PROCESSES. PROVIDE STATE OF READINESS.

(P019) TITLE - DEVELOP MANUFACTURING TECHNOLOGY FOR 40MM SMOKE CANOPIES

250

PROBLEM - MOBILIZATION REQUIREMENT. NO CURRENT PRODUCTION FACILITY. NEED PRODUCTION PROVE OUT.

SOLUTION - PROVIDE PILOT FACILITY TO PROVE OUT THE TDP. PROVIDE DESIGN CRITERIA AND PROCESS BASELINE.

MMT FIVE YEAR PLAN  
RCS DRCHT 126

FUNDING (\$000)

PRIOR 80 81 82 83 84

COMPONENT -- PYROTECHNICS

(CONTINUED)

(P020) TITLE - INCENDIARY MIX STUDY

350

PROBLEM - TECHNOLOGY OUTDATED. FACILITIES OLD AND LABOR INTENSIVE. HEAVY POLLUTANT.

SOLUTION - PERFORM STUDY TO PROVIDE UPDATED EQUIPMENT. PROVIDE STATE OF ART TECHNOLOGY. LIMIT POLLUTION FROM PLANT.

(1347) TITLE - ADVANCED TECH FOR MANUFACTURE OF RED PHOSPHORUS

300

PROBLEM - THERE IS A HIGH TRADOC PRIORITY FOR A FAMILY OF NEW SMOKE MU MUNITIONS. THE L8A1 DOES CONTAIN RED PHOSPHORUS AND THE 155MM AND THE 105MM ARE POSSIBLE CANDIDATES FOR IT. HOWEVER RED PHOSPHORUS IS NOT PRODUCED IN THE US.

SOLUTION - IN ORDER TO HAVE AN ADEQUATE MOBILIZATION SUPPLY OF RP, DEVELOP THE TECHNOLOGY REQUIRED TO DESIGN A RED PHOSPHORUS FACILITY.

(2708) TITLE - MODERNIZATION FOR SMALL PYROTECHNIC ITEMS

700

PROBLEM - THIS EFFORT ADDRESSES SMALL PYROTECHNIC ITEMS CHARACTERIZED BY PRODUCT COMPLEXITY + RELATIVELY HIGH QUANTITY REQ. ITEMS WERE PRODUCTION ENGINEERED FOR ASSEMBLY ON LINES W/MOST OPERATIONS BEING PERFORMED MANUALLY. AUTO PROD HAS BEEN ON THIS BASIS.

SOLUTION - PROJECT WILL INTRO AUTO PROD + IN-PROCESS QUALITY CHECKING TO KEY OPS OF SMALL PYROTECHNIC ITEMS. HARDWARE DEV WILL BE SUIT F/INTEGRATION INTO FULLY AUTO LINES. PROJ EFFORT WILL RESULT IN DEV, TEST + INSTAL OF PROTOTYPE MFG MACH F/HAND HELD SIGNALS

(4161) TITLE - PROC TECH FOR PDN OF 81 MM IMPRV SMOKE MUN

485

PROBLEM - A REQUIREMENT EXISTS FOR APPLYING THE IMPROVED SMOKE CONCEPT TO FILLING THE WARHEAD FOR THE 81 MM MORTAR.

SOLUTION - CONDUCT PROCESSING TECHNIQUE STUDIES FOR PREMIX, FILL, CLOSE AND LAP MINITIONS PRODUCTION PROCESS DATA.

(4417) TITLE - USE OF RED PHOSPHORUS IN SMOKE POT APPLICATIONS

304

PROBLEM - SMOKE PRODUCED FROM HC HAS LED TO SOME INJURIES AND IS SUSPECTED OF BEING A CARCINOGEN. R+D WORK IS BEING DONE TO DEVELOP A RED PHOSPHORUS MIX TO REPLACE HC. HOWEVER NO LARGE SCALE RP PREPARATION FACILITIES CURRENTLY EXIST.

SOLUTION - DEVELOP THE TECHNOLOGY AND ESTABLISH A PROTOTYPE FACILITY WHICH WILL ON A LARGE SCALE PREPARE FOR LOADING THE RP FORMULATION WHICH IS DEVELOPED IN R+D

\*\*\*\*\*  
 \* C A T E G O R Y \*  
 \*-----\*  
 \*ENERGY CONSERVATION \*  
 \*\*\*\*\*

MMT FIVE YEAR PLAN  
 RCS DRCHT 126

FUNDING (\$000)

PRIOR 80 81 82 83 84  
 -----

COMPONENT -- GENERAL

(1707) TITLE - INDUSTRIAL ENERGY SURVEY

180

PROBLEM - ENERGY SURVEY MUST BE CONDUCTED. CURRENT NATURAL GAS/FUEL OIL BOILERS WERE INSTALLED IN 1940S + ARE NOW BEYOND NORMAL REPLACEMENT AGE.

SOLUTION - COMP PROCESS ENERGY SURVEY WILL BE CONDUCTED IN MULTIPLE PDN AREAS+RELATED PROC REL TO MIXING,FILL + PRESS, + LAP + DET CURRENT ENERGY RQMTS.EVAL OF CONTINUOUS MONITOR TIED TO MICROPROCESSOR WILL BE EVAL TO INSURE CLOSE CONTROL + MGMT OF ENERGY RQMTS

(2732) TITLE - UTILIZATION OF PASSIVE ENERGY IN AAPs

300

PROBLEM - WITH THE INCREASE IN ENERGY COSTS IT BECOMES NECESSARY TO REVIEW OLD SOLUTIONS WHICH WERE NOT COST EFFECTIVE, BUT WHICH COULD BE IN TODAYS ECONOMIC ENVIRONMENT.

SOLUTION - UTILIZE THE NEAR CONSTANT GROUND TEMPERATURE (55F) FOR COOLING AND HEATING PURPOSES.

(2740) TITLE - CAD OF AAP'S BASED ON ENERGY CONSIDERATIONS

300 200

PROBLEM - ADAPT NECAP (NASA ENERGY COST ANALYSIS PROGRAM) TO ACCOUNT FOR THE UNIQUE DESIGN FEATURES OF AAPs.

SOLUTION - NECAP IS A PROGRAM FOR DETERMINING BUILDING DESIGN COST EFFECTIVENESS BASED ON ENERGY CONSIDERATIONS. MUST BE ADAPTED TO THE UNIQUE DESIGN FEATURES FOUND IN AAPs.

(4224) TITLE - ENERGY CONSERVATION IN SOLVENT RECOVERY OPERATIONS

229 200

PROBLEM - ACTIVATED CARBON SOLVENT RECOVERY AFFORDS HIGH POTENTIAL FOR ENERGY SAVINGS BY USE OF HEAT TRANSFER TECHNOLOGY.

SOLUTION - USE OF A FUME RECIRCULATION SYSTEM BASED UPON TRW CONCEPT IN PLACE OF STEAM DISTILLATION PROCESS.

(4281) TITLE - CONSERVATION OF ENERGY AT AAPs

4217 1234 1207 1690 1076 1250

PROBLEM - PETROLEUM MAY NOT BE AVAILABLE IN FUTURE TO MEET PRODUCTION REQUIREMENTS.

SOLUTION - DEVELOP ENERGY SAVING TECHNOLOGY TO APPLY TO AAP MANUFACTURING FUNCTIONS TO REDUCE QUANTITY OF ENERGY USED AT ALL LEVELS OF PRODUCTION.

\*\*\*\*\*  
 \* C A T E G O R Y \*  
 \*-----\*  
 \*EXPLOSIVES \*  
 \*\*\*\*\*

MMT FIVE YEAR PLAN  
RCS DRCMT 126

FUNDING (\$000)

PRIOR 80 81 82 83 84  
-----

COMPONENT -- COMP B

(4037) TITLE - PROCESS IMPROVEMENT FOR PLASTIC-BOND EXPLOSIVES

236 750 709

PROBLEM - PRESENT METHODS OF PRODUCING PBX COMPOSITIONS ARE JOB-SHOP ORIENTED AND UNECONOMICAL FOR LARGE SCALE PRODUCTION PROJECTED IN THE FUTURE.

SOLUTION - DEVELOP NEW TECHNIQUES OF COATING, DRYING, AND PACKAGING PBX COMPOSITIONS. FIRST ATTEMPT WILL BE TO EVALUATE EQUIPMENT SELECTED FOR COMPOSITION C4 UNDER PROJ 4449.

(4267) TITLE - CONTINUOUS PROCESS FOR GRANULAR COMPOSITION B

1584 757

PROBLEM - THE BATCHWISE COOLING PROCESS OF RDX/TNT/WAX & DRYRY ALLOWS ONLY A LIMITED CONTROL OF GRANULATION.

SOLUTION - DEVELOP AND USE A CONTINUOUS PROCESS TO PRODUCE GRANULAR COMPOSITION B.

COMPONENT -- HMX/RDX

(4310) TITLE - DMSO RECRYSTALLIZATION OF HMX/RDX

1744 278

PROBLEM - THE CURRENT METHOD OF RECRYSTALLIZING HMX/RDX IS INEFFICIENT AND UNECONOMICAL. IT REQUIRES LARGE AMOUNTS OF RAW MATERIALS (ESP CYCLOHEXANONE OR ACETONE), PROCESS VESSELS, AND MANPOWER.

SOLUTION - A SOLVENT WITH MUCH GREATER SOLVATING POWER IS REQUIRED. DMSO IS SUCH A SOLVENT AND CAN BE USED FOR PROCESSING LARGE AMOUNTS OF HMX/RDX. THIS PROJECT IS DEVELOPING A PILOT SCALE PROCESS FOR RECRYSTALLIZING HMX/RDX USING DMSO.

(4404) TITLE - RECOVERY OF ACETIC ACID IN RDX MANUFACTURING

250 200

PROBLEM - FORMIC ACID IN THE "A" AREA AZEO STILL AT HSAAP CAUSES PROBLEMS. FIRST THE STILL MUST BE MADE OF HASTALLOY VS STAINLESS AND SIDE REACTIONS CAUSE STEAM USAGE TO GO UP 140 PERCENT AND THE ENTRAINER TO BE REPLACED TWICE A YEAR.

SOLUTION - NEUTRALIZE THE FORMIC ACID PRIOR TO ITS INTRODUCTION TO THE AZEO STILL.

(4406) TITLE - IMPROVING THE YIELD OF HMX DURING RDX NITROLYSIS

655

PROBLEM - THE CURRENT MANUFACTURING PROCESS FOR HMX IS INEFFICIENT IN THAT YIELDS OBTAINED ARE STILL LESS THAN THEORETICAL.

SOLUTION - THE CURRENT BACHMANN PROCESS WILL BE MODIFIED TO INCREASE THE HMX YIELD BEYOND 30 PERCENT.

FUNDING (\$000)

PRIOR 80 81 82 83 84

COMPONENT -- HMX/RDX

(CONTINUED)

(4449) TITLE - PROCESS IMPROVEMENT FOR COMPOSITION C-4

330 339 531

PROBLEM - THE EXISTING FACILITIES WHICH ARE COMMON TO THE MANUFACTURE OF COMP B AND THE OTHER RDX COMPOSITION WOULD LIMIT THE AVAILABILITY OF THESE ITEMS BELOW THEIR MOB REQUIREMENTS.

SOLUTION - ESTABLISH NEW PROCESSES AND METHODS FOR THE MANUFACTURE OF THESE ITEMS TO MINIMIZE THE IMPACT OF COMMON OPERATIONS ON CAPACITY.

(4508) TITLE - PROCESS IMPROVEMENTS FOR PRESSABLE RDX COMPOSITIONS

657 506 263

PROBLEM - HSAAP IS HINDERED WITH PROCESS BOTTLENECKS IN MANUFACTURING A COMPS. PROCESSING USES JOB SHOP TECHNIQUES AND IS LABOR INTENSIVE. OVERALL PRODUCTION FACILITIES ARE SEVERELY CONSTRAINED AND OPERATE UNDER SAFETY WAIVERS DUE TO OUTDATED TECHNOLOGY USED.

SOLUTION - PRIMARY BOTTLENECKS ARE IN THE COATING AND DRYING AREAS. THIS PROJECT INVESTIGATES VARIOUS WAYS TO ELIMINATE THESE BOTTLENECKS, EVALUATE THEM AND GENERATE SUFFICIENT PILOT SCALE DATA TO ALLOW DESIGN OF THE IMPROVED PROCESS.

COMPONENT -- PROCESS CONTROL

(1905) TITLE - PBX CONTINUOUS CAST FOR MUNITION LOADING

864 934

PROBLEM - ADDED USE OF CASTABLE PLASTIC BONDED EXPLOSIVES WILL CREATE PRODUCTION SHORTFALLS. MOST PBX CAN NOT BE USED IN PRESENT MELT / CAST EQUIPMENT. PBX PRODUCTION IS NOW DONE AT 2 NAVY PLANTS WHICH COULD NOT HANDLE LOADING OF CASTABLE PBX IN BOMBS.

SOLUTION - ESTABLISH HIGH PRODUCTION RATE CONTINUOUS PROCESSES FOR MIX AND CAST OF VARIOUS PBX FORMULATIONS. IDENTIFY + EVALUATE EQUIPMENT + PROCESSES, SELECT + TEST EQUIPMENT + INTEGRATE ACCEPTABLE ITEMS INTO AN OPERATING PBX PROCESSING PILOT PLANT.

COMPONENT -- TNT

(L292) TITLE - AUTOMATED FLAKER MOLTEN TNT DETECTOR

195

PROBLEM - WHEN TNT DOES NOT SOLIDIFY ON FLAKER DRUM IT FALLS INTO HOPPER WHERE IT SOLIDIFIES AND STOPS THE FLOW OF TNT FLAKES. OPERATIONS MUST BE STOPPED UNTIL THE HAZARDOUS REMOVAL OF TNT FROM HOPPER BY REAMING OR RAPPING IS COMPLETED.

SOLUTION - A MOLTEN TNT DETECTOR WILL BE DEVELOPED TO DETECT PRESENCE OF MOLTEN TNT ON FLAKER DRUM AND STOP THE FLAKING OPERATION. THIS WILL PREVENT MOLTEN TNT FROM ENTERING THE HOPPER.

PRIOR 80 81 82 83 84

COMPONENT -- TNT (CONTINUED) 29 302 498

(4200) TITLE - TNT CRYSTALLIZER FOR LARGE CALIBER  
 PROBLEM - TNT MELT LOADING REQUIRES AN OPTIMUM RATIO OF MOLTEN AND SOLID TNT IN THE EXPLOSIVE MIX AT THE TIME OF POUR. THE RATIO IS OBTAINED BY THE ADDITION OF FLAKE TNT TO A QUANTITY OF MOLTEN TNT BASED ON OPERATOR JUDGEMENT.

SOLUTION - DEV A DEVICE WHICH UTILIZES MOLTEN TNT TO GEN A SLURRY CONSISTENCY THROUGH PARTIAL CONTROLLED, STEADY-STATE CRYSTALLIZATION. BY CLOSE CONTROL OF TNT FLOW RATE AND THERMAL PARAMETERS, A CONTINUOUS FINE GRAINED SLURRY MIX OF PROPER RATIO WOULD RESULT.

(4237) TITLE - CONTINUOUS TNT PROCESS ENGINEERING 2486 354 950 200  
 PROBLEM - CURRENT CIL PROCESS REQUIRES PROCESS AND SAFETY IMPROVEMENTS.  
 SOLUTION - DESIGN AND BUILD A CIL LINE TO TEST PROCESS IMPROVEMENTS.

(4452) TITLE - REPROCESSING DEMILLED EXPLOSIVES 281  
 PROBLEM - LARGE QUANTITIES OF AMMUNITION IN INVENTORY ARE INCREASING RAPIDLY AND OCCUPYING PRIME COVERED STORAGE AREAS.

SOLUTION - TNT AND TNT BASED EXPLOSIVES REMOVED FROM DEMILLED AMUNITION WILL BE RECLAIMED AND REFINED FOR REUSE IN THE LOADING OF AMMUNITION.

\*\*\*\*\*  
 \* C A T E G O R Y \*  
 \*-----\*  
 \*FUZES\*  
 \*\*\*\*\*

COMPONENT -- ELECTRONICS  
 (L222) TITLE - BORESIGHTING OF SFF WHD W/IR SENSOR 200 145

PROBLEM - NO PRODUCTION PROCESS EXISTS TO BORE SIGHT STORM WARHEAD TO IR SENSOR. PRESENT HAND PROCESS REQUIRES SEVERAL HOURS AND IS UNRELIABLE.  
 SOLUTION - DEVELOP EQUIPMENT TO AUTOMATE PROCESS.

(1005) TITLE - CERAMIC-METAL SUBSTRATES FOR HYBRID ELECTRONICS 319  
 PROBLEM - ALL THICK FILM HYBRIDS ARE FABRICATED ON A CERAMIC SUBSTRATE WHICH IS FRAGILE AT HIGH G SHOCK LEVELS AND MUST BE ADEQUATELY SUPPORTED IN ORDER TO SURVIVE. THIS IS A COSTLY PROCEDURE.

SOLUTION - DEVELOP MFG METHODS + TECHNIQUES FOR PRODUCTION OF THICK FILM HYBRID CIRCUITRY ON METAL-BASED SUBSTRATES. THIS INCLUDES PROCESSES FOR AN INSULATING LAYER ON A METAL SUBSTRATE AND PROCESSING OF THICK FILM MATERIALS TO FORM ELECTRONIC COMPONENTS.

COMPONENT -- LAP

(L297) TITLE - TECHNIQUE FOR APPLYING SEALANT MATERIAL

175

PROBLEM - IN CURRENT METHODS OF ASSEMBLY OF FUZES, SEALING MATERIEL IS APPLIED TO MATING PARTS AS THEY ARE SECURED TOGETHER, OFTEN LEAVING SEALANT BEAD AND HOLES IN SEALANT WHEN IT DRIES. HOLES CAN CAUSE WATERPROOF FAILURES.

SOLUTION - AN ENGINEERING STUDY PROPOSAL FOR IMPROVING SEALING.

(1003) TITLE - LOW COST MOLDED PACKAGING FOR HYBRID ELECTRONICS

243

PROBLEM - FOAM OR EPOXY POTTED HYBRID CIRCUITS USED IN SMALL CALIBER ARE NOT SURVIVING HI G LEVELS. HERMETIC PACKAGES ARE NOT USED DUE TO COST CONSIDERATIONS.

SOLUTION - APPLY MOLDING TECHNIQUES THAT ARE USED IN DUAL-IN-LINE PLASTIC PACKAGES. THIS PROCESS IS BASED UPON BULK FILM PROTECTION OF THE SUBSTRATE FOLLOWED BY MOLDING OF THE ELECTRONICS AND METAL PLATING TO PROVIDE SHIELDING IF REQUIRED.

(2737) TITLE - AUTOMATED PACKOUT OF M223 FUZE

800

PROBLEM - MMT PROJ CURRENTLY UNDER CONTRACT TO AUTO ASSEMBLE M223 FUZE AT MINIMUM RATE OF 90 ASSEMBLIES PER MINUTE. MANUAL PACKOUT OF M223 FUZES INTO SHIP + STORAGE CONTAINERS AT HIGH PROD RATE WOULD BE A HIGH LABOR INTENSIVE OPR. UP TO 500 ASSEMBLIES PER MINUTE

SOLUTION - DEVELOP AN AUTOMATED PACK OUT LINE TO MATE WITH THE AUTOMATIC ASSEMBLY EQUIPMENT.

COMPONENT -- METAL PARTS

(2735) TITLE - POWDER METALLURGY FUZE COMPONENTS

300 170

PROBLEM - MACHINING FUZE METAL PARTS FROM BAR STOCK IS TIME CONSUMING + GENERATES A LARGE AMOUNT OF SCRAP. THERE IS A NEED TO DEV ALTERNATE PROCESS FOR FABRICATING FUZE PARTS THAT ARE MACHINED FROM BAR STOCK.

SOLUTION - DEVELOP ALTERNATE PROCESSES FOR FABRICATING FUZE PARTS THAT ARE MACHINED FROM BAR STOCK.

(4402) TITLE - HSS PRECISION GEAR HOBBS

1447

PROBLEM - THE FUZE PRODUCTION BASE UTILIZES SOLID CARBIDE HOBBS FOR MFG PINIONS. THERE IS NO DOMESTIC MFR OF THESE HOB. THEY ARE IMPORTED FROM FOREIGN SOURCES. LEAD TIME IS 10 TO 18 WEEKS. A SURVEY SHOWED A LACK OF TECH, SKILLS + INTEREST IN MFG.

SOLUTION - DEVELOP IMPROVED HIGH SPEED STEEL HOBBS USING HIGH STRENGTH STEEL TO IMPROVE WEAR LIFE AND PROVIDE A BACKUP FOR MOB AND LEADTIME RED UCTION USING U.S. AVAILABLE TECHNOLOGY.

FUNDING (\$000)

PRIOR 80 81 82 83 84

COMPONENT -- METAL PARTS (CONTINUED)

(4434) TITLE - MFG, TEST, AND INSP EQPT F/XM763, 105MM FUZE 450 475

COMPONENT -- POWER SUPPLIES

(1001) TITLE - PILOT LINE FOR FUZE FLUIDIC POWER SUPPLIES 253 315

PROBLEM - FLUIDIC GENERATORS ARE COMPLEX AND COSTLY TO PRODUCE. IN PRODUCTION, CLOSE TOLERANCES AND SMALL PART ASSEMBLY ARE REFLECTED IN HIGH COST AND LOW YIELD.

SOLUTION - IDENTIFY AND ADOPT THE MOST ECONOMICAL MFG PROCESSES AND TECHNIQUES TO ESTABLISH A MECHANIZED PILOT LINE FOR ASSEMBLY OF FLUIDIC POWER SUPPLIES.

(4266) TITLE - MANUFACTURING, INSPECTION AND TEST EQUIP FOR MAG PWR SUPPLY 345 759

PROBLEM - PIEZOELECTRIC POWER SUPPLIES USED IN HEAT AMMO HAVE BEEN OBSERVED TO HAVE UNDESIRABLE VOLTAGE GENERATION IMPRESSED ON THE ELECTRICAL CIRCUITING OF THE ROUND DUE TO SHOCK VIBRATIONS RESULTING DURING FLIGHT WHICH MAY CAUSE PREMATURES.

SOLUTION - MOVE THE POWER SUPPLY FROM THE NOSE OF THE ROUND TO INSIDE THE PIBD FUZE HOUSING AND CHANGE IT TO A MAGNETIC PULSE GENERATING TYPE POWER SUPPLY WHICH IS UNAFFECTED BY THE PROBLEM OF SHOCK VIBRATIONS.

COMPONENT -- QA/TESTING

(0024) TITLE - IN PROCESS INSPECTION OF ENCAPSULANT MATERIAL 300

PROBLEM - PROCESS TECHNOLOGY FOR PLASTIC ENCAPSULANTS WAS DEVELOPED UNDER 578 5907 HOWEVER INSPECTION TECHNIQUES FOR THOSE ENCAPSULANTS WERE NOT DEVELOPED

SOLUTION - DEVELOP A NON DESTRUCTIVE INSPECTION TECHNIQUE TO DETERMINE IF VOIDS EXIST IN THE MATERIAL. THIS WILL INCREASE YIELDS AS WELL AS PROVIDE 100% INSPECTION CAPABILITY.

(3961) TITLE - IMPROVE (3-D) VIBRATION ACCEPT TEST F/M732 M724 282 352 253

PROBLEM - CURRENT METHODS ARE COSTLY AND TIME CONSUMING, RARELY EXPOSE THE TEST ITEM TO TRUE SERVICE ENVIRONMENTS, AND REQUIRE THREE TESTS TO ACCOUNT FOR ALL TEST AXES.

SOLUTION - USE OF COMPUTERIZED 3-D VIBRATION / SHOCK TESTING AS AN ACCEPTANCE TOOL SOLVES TECHNICAL + ECONOMIC TEST DEFICIENCIES. TEST TIME IS REDUCED

(4360) TITLE - HIGH SPEED DIMENSIONAL INSP OF FUZE COMP 200

PROBLEM - FUZE PRECISION PLATES ARE INSPECTED BY SAMPLING AND MANUAL METHODS.

SOLUTION - PROVIDE 100 PERCENT HIGH SPEED AUTOMATED INSPECTION PRODUCTION. TRENDS CAN BE RECORDED FOR PROCESS CONTROL.

MMT FIVE YEAR PLAN  
RCS DRCMT 126

\*\*\*\*\*  
\* C A T E G O R Y \*  
\*-----\*  
\*GENERAL\*  
\*\*\*\*\*

FUNDING (\$000)

PRIOR 80 81 82 83 84  
-----

COMPONENT -- MISCELLANEOUS

(L223) TITLE - FOAM IN PLACE MUNITION BODY F/XM84

100 120

PROBLEM - DEVELOP PROCESS TO ENCAPSULATE MAJOR MUNITION COMPONENTS WHERE INTERNAL STRESSES WOULD BE MINIMIZED, PREALIGNMENTS OF ELEMENTS WOULD NOT BE DISTURBED AND EXOTHERM WOULD BE COMPATIBLE WITH EXPLOSIVES AND OTHER TEMPERATURE SENSITIVE COMPONENTS.

SOLUTION - DETERMINE OPTIMUM COMBINATION OF FOAM IN-PLACE MATERIALS AND COMPONENT ALIGNMENT PROCESS TO ALLOW FOR ENCAPSULATION OF INTERNAL COMPONENTS FOR XM84.

(0915) TITLE - GRP TECH RQMTS DEFINITION ELECTRONICS

30

PROBLEM - CLASSIFICATION AND CODING SYSTEMS AND GROUP TECHNOLOGY HAVE BEEN DEVELOPED AND USED FOR BATCH MANUFACTURING OF MACHINED PARTS. POTENTIAL EXISTS FOR APPLYING THESE TECHNIQUES TO ELECTRONICS.

SOLUTION - THROUGH EVALUATION AND ANALYSIS OF THE PERCEIVED NEEDS FOR A G.T. CLASSIFICATION AND CODING SYSTEM FOR ELECTRONICS COMPONENTS, A DEFINITION OF THE ESSENTIAL PARAMETERS TO WHICH SUCH A SYSTEM SHOULD RESPOND WILL BE DEVELOPED.

(1400) TITLE - SPT FOR NORWEGIAN MULTI PURP PROJECTILE

450

(2742) TITLE - LASER APPLIED DURABLE COATINGS

150 200

PROBLEM - PRODUCTIVITY IS A FUNCTION OF RAM TO INCREASE RELIABILITY AND REDUCE MAINTENANCE DOWNTIME AND COST IN THE MUNITIONS PLANT ENVIRONMENT IS VERY DIFFICULT.

SOLUTION - UTILIZE LASER APPLIED DURABLE COATINGS ON MACHINE AND TOOL WEAR SURFACES AND IN CORROSIVE ENVIRONMENTS.

(4309) TITLE - PROCESS DEVEL F/120MM AMMO

848 3726 3988 3948

PROBLEM - MASS PRODUCTION IN THE US OF W. GERMAN 120MM TANK AMMUNITION POSES PROBLEMS IN FOUR FUNCTIONAL AREAS - METAL PARTS, PROPELLANT, FUZE, AND LAP.

SOLUTION - THIS IS A MULTI-YEAR EFFORT IN FOUR FUNCTIONAL AREAS. A SEPARATE TASK ADDRESSES EACH UNIQUE PROBLEM. THIS MMT SUPPORTS FACILITY PROJECTS IN FY83-84 AND IS ESSENTIAL TO FIELDING THE 120MM GUN SYSTEM ON THE XM1 TANK IN FY85.

(6736) TITLE - TECH READINESS ACCEL THRU COMPUTE INTEGRATED MFG (TRACIM)

531 315 266

PROBLEM - THE LEAD TIME REQUIRED TO BRING PRODUCTION LINES TO MOBILIZATION MAXIMUM IS INTOLERABLY EXCESSIVE. A CRITICAL DETERRENT IS THE EXTREME SHORTAGE OF TOOLMAKERS AND MACHINISTS.

SOLUTION - THE DEVELOPMENT AND IMPLEMENTATION OF A COMPUTER INTEGRATED MANUFACTURING SYSTEM WILL SIGNIFICANTLY REDUCE THE REQUIREMENT FOR HIGHLY SKILLED CRAFTSMEN.

\*\*\*\*\*  
 \* C A T E G O R Y \*  
 \*-----\*  
 \*LAP  
 \*\*\*\*\*

RHT FIVE YEAR PLAN  
 RCS DRCMT 126

FUNDING (\$000)

PRIOR 80 81 82 83 84  
 -----

COMPONENT -- ASSEMBLY

(L263) TITLE - VIPER MECH ASSY OF COMPLETE ROUND TO LAUNCHER 645 275

PROBLEM - THE ASSEMBLY OF ROUND TO LAUNCHER IS A COSTLY OPERATION DUE TO HIGH LABOR COSTS.

SOLUTION - A STUDY WILL BE CONDUCTED TO DETERMINE THE AREAS WHERE MECHANIZATION CAN BE APPLIED. APPLICABLE AREAS WILL BE MECHANIZED INTO AN ASSEMBLY SYSTEM.

(2700) TITLE - LAP CENTER CORE PROPELLING CHARGES 150

PROBLEM - TACK SEWING END SEAMS OF BASE IGNITER ASSEMBLY + BODY ASSEMBLY REQUIRES NEW SEW MACHINE APPROACH/TECHNIQUE. THIS IS REQUIRED TO REDUCE COSTS BY REDUCING NUMBER OF PERSONNEL NEEDED TO PERFORM SEWING OPERATIONS.

SOLUTION - EVALUATE CURRENT STATE-OF-THE-ART SEWING MACHINE TECHNIQUES TO INCORPORATE A METHOD COMPATIBLE WITH AUTOMATED LAP EQUIPMENT. BUILD A MOCK-UP OF THE SEWING STATION.

(2706) TITLE - AUTOMATIC PROCESSING OF PARACHUTE ASSEMBLIES 215 160

PROBLEM - PARACHUTE ASSEMBLY AT PRESENT IS AN OPERATOR CONTROLLED PROCESS DEVELOPED FROM HAND FOLDING OF MANNED PARACHUTES. THIS IS A TIME CONSUMING AND COSTLY PROCESS REQUIRING EXPERIENCE AND DEXTEROUS PERSONNEL.

SOLUTION - UTILIZING FAVORABLE RESULTS OF PRIOR YEAR FEASIBILITY STUDIES, BUILD AND TEST A FULL SCALE PROTOTYPE SYSTEM FOR ECONOMICAL, RELIABLE, HIGH-RATE, SEMI-AUTOMATIC ASSEMBLY OF PARACHUTE COMPONENTS FOR AMMUNITION ITEMS.

(2710) TITLE - MODIFICATION OF LINE F/LAP OF UK PROPELLING CHARGE 700

PROBLEM - HAND LINE LOADING/ASSEMBLY OF UK CHARGE WHEN ADOPTED WOULD BE REQUIRED WITH THE RESULTING HIGH COST, GREATER EXPOSURE OF PERSONNEL TO FLAMMABLE/EXPLOSIVE MATERIALS AND LESS RELIABLE PRODUCT.

SOLUTION - DEVELOP TOOLING/EQUIPMENT MODIFICATION REQUIREMENTS FOR AUTOMATICALLY LOADING/ASSEMBLING UK CHARGE ON THE AUTOMATED LAP LINE FOR US M204/M205 PROPELLING CHARGE.

(4000) TITLE - AUTO M55 DETONATOR PRODUCTION EQUIPMENT 6630 250 604

PROBLEM - LAP OF DETONATORS IS LABOR INTENSIVE. PERSONNEL EXPOSURE IS EXTENSIVE. MOB RATES ARE EXTREMELY HIGH.

SOLUTION - DEVELOP AN AUTOMATED SYSTEM FOR PRODUCTION OF NON-ELECTRIC DETONATORS TO PRODUCE HIGH QUALITY DETONATORS WITH REDUCED COST AND IMPROVED SAFETY.

FUNDING (\$000)

PRIOR 80 81 82 83 84

COMPONENT -- ASSEMBLY

(CONTINUED)

(4062) TITLE - AUTO MFG SUPPORT FOR MORTAR INCREMENT CONTAINERS 507 884 1575 1439

PROBLEM - THE MANUFACTURE AND ASSEMBLY OF THE 60/81MM PROP CHARGE INCREMENT CONTAINER IS LABOR INTENSIVE AND DOES NOT MEET PRODUCTION REQUIREMENTS.

SOLUTION - DEVELOP PROCESS AND EQUIPMENT TO REDUCE COSTS, INCREASE PRODUCTION RATES, AND IMPROVE QUALITY.

(4138) TITLE - EQUIPMENT FOR AUTO PROCESSING OF ADDITIVE LINER 379

PROBLEM - PIP IS BEING EXECUTED TO ELIMINATE THE SEWING OF THE PROTECTIVE FILM TO ADDITIVE LINERS. ANOTHER TASK IS THE DEV OF AN ABLATIVE TYPE WEAR REDUCER (SILICON GREASE BAGGED IN MYLAR FILM) MFG EQUIP IS REQUIRED F/EITHER GUN TUBE WAER REDUCER.

SOLUTION - AUTOMATED EQUIPMENT WILL BE DEVELOPED IN THE CASE OF SEWING ELIMINATION OF THE MYLAR FILM. AUTOMATED EQUIPMENT WILL BE DEVELOPED FOR METERING AND PACKAGING THE NEW ABLATIVE TYPE GUN TUBE WEAR REDUCER.

(4311) TITLE - AUTO PROD EQUIP FOR LAP OF XM 692 MINE DISPENSING SYSTEM 2683 466

PROBLEM - PRESENT PRODUCTION FACILITY TO LAP THE XM692 MINE DISPENSING SYSTEM IS LIMITED TO A MANUAL/MANUAL ASSIST OPERATION WITH ATTENDANT PRODUCTION UNIT COSTS AND HIGH PERSONNEL EXPOSURE.

SOLUTION - PROJECT WILL PROVIDE EQUIPMENT DESIGNS AND PROTOTYPE EQUIPMENT TO AUTOMATICALLY LOAD AND ASSEMBLE THE XM67 MINE, THEREBY REDUCING PERSONNEL HAZARDS AND PRODUCTION COSTS WHILE PROVIDING A MORE UNIFORM AND RELIABLE ITEM.

(4368) TITLE - DEV AUTOMATED EQPT FOR SEALING M55 DETONATORS 672

PROBLEM - CURR M55 DETS ARE BEING LACQUERED. 2 APPROACHES TO SEALING ARE BEING INVEST. 1 USED FOIL PRECOATED W/ADHESIVE + THE OTHER WELDS THE DET CUP TO FOIL. BOTH CAN BE PERFORMED ON A LOADER-LESS HANDLING WILL REDUCE COST OF DET.

SOLUTION - DEVELOP EQUIPMENT BASED ON EITHER THE HOT MELT ADHESIVE OR ULTRA SONIC WELDING TECHNIQUE CURRENTLY BEING INVESTIGATED. RETROFIT BOTH SINGLE-TOOL AND MULTI-TOOL DETONATOR LOADERS WITH EQUIPMENT TO SEAL THE M55 DETONATOR.

(4383) TITLE - AUTOMATED EQUIPMENT FOR LOADING VIPER PIC BOOSTER 985 140

PROBLEM - PLANS TO ASSEMBLE PIC BOOSTER INCLUDE MANUALLY WEIGHING AND CONSOLIDATING VERY SMALL EXPLOSIVE CHARGES, PRECISION PLACEMENT OF A SMALL METAL PART AND APPLYING AN ADHESIVE COATED FOIL DISC. THIS WILL REQUIRE A HIGH CONCENTRATION OF LABOR AND HIGH COST

SOLUTION - DEVELOP AUTOMATED EQUIPMENT TO MECHANICALLY PERFORM THE REQUIRED OPERATIONS

FUNDING (\$000)

PRIOR 80 81 82 83 84  
-----

COMPONENT -- ASSEMBLY

(CONTINUED)

(4385) TITLE - MECH OF ASSY OPERATION OF CENTER CORE IGNITERS 542

PROBLEM - CURRENT TECHNIQUES TO ASSEMBLE THE CLOTH IGNITER ASSEMBLY TO THE IGNITER TUBE REQUIRES LARGE NUMBERS OF OPERATORS HANDLING HIGHLY HAZARDOUS BLACK POWDER.

SOLUTION - THIS PROJECT WILL DEVELOP EQUIPMENT TO MECHANICALLY ASSEMBLE THIS IGNITER ASSEMBLY. THIS WILL ENABLE THE REDUCTION OF PERSONNEL IN HAZARDOUS OPERATIONS.

(4418) TITLE - APPLICATION OF ROBOTS TO LAP FASCAM MINES 730

PROBLEM - MINE LAP IS BASICALLY #PICK AND PLACE# OF MPTS TO EXPLOSIVE COMPONENTS. RELIABILITY + ECONOMIC PRODUCTIVITY ARE THE USUAL FACTORS OF CONCERN. PDN RATES PRECLUDE ECONOMIC APPLICATION OF DEDICATED AUTO LINES.

SOLUTION - RECENT DEV OF SMALL, PROGRAMMABLE ROBOT ARMS DESIGNED FOR ECONOMIC BATCH ASSY TASKS. ARMS ARE LOW COST, VERSATILE, + SELF CONTAINED. THEY CAN BE READILY SUBSTITUTED INTO A MANUAL LINE W/O MODIFYING THE FACILITY.

(4420) TITLE - VIPER WARHEAD ASSEMBLY 625 215

PROBLEM - THE WARHEAD ASSEMBLY REQUIRES EXTREME CARE IN PLACING WIRE IN ITS PROPER LOCATION. THIS OPERATION IS LABOR INTENSIVE.

SOLUTION - DEVELOP MECHANIZED EQUIPMENT TO COMPLETE THIS PORTION OF ASSEMBLY.

(4422) TITLE - LOAD/ASSEMBLY EQPT FOR COMBINED EFFECTS MUNITIONS 137 1150

PROBLEM - NO FACILITIES EXIST FOR PRODUCING THE COMBINED EFFECTS BOMB ASSEMBLY. WITHOUT A MECHANIZED ASSEMBLY SYSTEM, COSTLY HAND METHODS WILL HAVE TO BE UTILIZED FOR THIS ITEM.

SOLUTION - DESIGN AND FABRICATE A SEMIAUTOMATED SYSTEM CAPABLE OF SUSTAINING MOB REQUIREMENTS WITH A MINIMUM OF PERSONNEL HAZARD. MODULAR CONVEYOR CONSTRUCTION WILL BE USED FOR FLEXIBILITY. ASSEMBLY WILL BE WITH TOP OR SIDE MOUNTED SUBASSEMBLY FIXTURES.

(4433) TITLE - FILM BRIDGE DETONATOR 245

PROBLEM - THE M456A1 HEAT CARTRIDGE CONTAINS A FILM BRIDGE THAT REQUIRES A HIGH DEGREE OF PRECISION TO FABRICATE AND ASSEMBLE. NO MANUFACTURING EQUIPMENT EXISTS TO PRODUCE THESE DETONATORS.

SOLUTION - INITIATE A 2 YEAR PROGRAM TO DESIGN EQUIPMENT TO ACCOMPLISH THE NECESSARY MANUFACTURING, INSPECTION AND TESTING METHODS UTILIZING EXISTING EQUIPMENT WHERE POSSIBLE, MODIFYING IT OR DESIGNING NEW STATIONS AS NECESSARY.

FUNDING (\$000)

PRIOR 80 81 82 83 84  
-----

COMPONENT -- ASSEMBLY

(CONTINUED)

(4469) TITLE - AUTOMATED INSERTION OF GRENADE LAYERS 1652 350

PROBLEM - THE MANUAL INSERTION GRENADE LAYERS INTO PROJECTILES IS A HIGHLY MANUAL, COSTLY AND HAZARDOUS OPERATION.

SOLUTION - DEVELOP AUTOMATED EQUIPMENT TO PERFORM THE INSERTION OF GRENADE LAYERS INTO THE M483-155MM PROJECTILE.

(4498) TITLE - CONSOLIDATION AND AUTOMATIC ASSEMBLY OF SMALL MINES 879 392

PROBLEM - OFF-LINE OPERATIONS AND MULTIPLE HANDLING IS REQUIRED FOR THE PREDOMINATELY MANUAL LAP OPERATIONS.

SOLUTION - THIS PROJECT WILL PROVIDE THE PROCESS PROCEDURES FOR CON SOLIDATING HE WITHIN THE MINE HOUSING. CONCEPTS FOR AUTOMATION OF THE A SSEMBLY OPERATIONS AND A FINAL REPORT.

(4501) TITLE - AUTOMATED HEAT SEALING OF IGNITER AND FLASH REDUCER BAGS 450

PROBLEM - IF HEAT SEALING COULD REPLACE SEWING PRODUCTION RATES COULD BE INCREASED

SOLUTION - INVESTIGATION OF HEAT SEAL PROCESSES AND TESTING OF BAG AND PROCESS APPROVAL

COMPONENT -- GENERAL

(2703) TITLE - THREAD CLEANING/INSPECTION OF HE LOADED MUNITIONS 240 150

PROBLEM - THE THREADS OF HE LOADED MUNITIONS ARE CLEANED INDIVIDUALLY BY HAND. THE OPERATION IS LABOR INTENSIVE AND HAZARDOUS TO THE OPERATOR.

SOLUTION - UTILIZING CURRENT TECHNOLOGY DESIGN + BUILD PROTOTYPE EQUIP THAT WILL CLEAN, INSPECT + TRANSFER THE MUNITION THROUGH ENTIRE OPERATION CYCLE AUTOMATICALLY.

(4251) TITLE - AUTO MANU OF DELAY FOR M549 AND XM650 PROJECTILES 993

PROBLEM - CURRENT OPERATION ARE LABOR INTENSIVE. COST OF ITEM IS HIGH.

SOLUTION - DEV/AUTO LAP EQUIP.

COMPONENT --- LOAD

(D0018) TITLE - MFG METHODS OF GEL FUEL FOR FAE II BOMBS	400
<p>PROBLEM - GELLED FUEL IS TO BE USED FOR PRODUCTION LOADING OF FUEL AIR EXPLOSIVE WEAPONS. THIS GEL WILL ENHANCE SAFETY BY ELIMINATING FLOWING FLAMMABLE FUEL HOWEVER TECHNOLOGY IS NOT AVAILABLE TO PLACE GEL FUEL PROCESSES INTO A PRODUCTION ENVIRONMENT.</p> <p>SOLUTION - DEVELOP A PROCESS TO MIX, TRANSPORT AND LOAD GEL FEUL INTO FAE WEAPONS.</p>	
(D020) TITLE - MFG TECH FOR LAP OF THE UK 81MM MORTAR PROP CHARGE	300
<p>PROBLEM - AT THE PRESENT TIME, NO PRODUCTION EQUIPMENT EXISTS FOR LAP OF THE UK 81MM PROP CHARGES.</p> <p>SOLUTION - INVESTIGATE ADAPTING AUTOMATED HORSESHOE LOADERS FOR LOADING, SEALING, AND INSPECTING CN PROP CHARGES.</p>	
(L249) TITLE - AUTOMATED LAP OF STICK-PROPELLANT CHARGES	500
<p>PROBLEM - STICK PROPELLANT CHARGES HAVE NO LAP PROCESSING PRECEDENT. CURRENT MANUAL METHODS OF PRODUCTION ARE INEFFECTIVE IN ACHIEVING SATISFACTORY LEVELS OF QUALITY, COST, SAFETY AND PRODUCTION READINESS.</p> <p>SOLUTION - EFFICIENT HIGH SPEED AUTO LAP EQUIPMENT WILL BRING PRODUCTION OF STICK PROPELLANT CHARGES TO A LEVEL CONSISTENT WITH MODERN TECHNOLOGY. AN INITIAL ENGINEERING STUDY TO DEFINE CONCEPTS AND PARAMETERS TO BE FOLLOWED BY PROTOTYPE EQUIPMENT IS PROPOSED.</p>	
(P018) TITLE - DEVELOP IMPROVED FILLING METHOD FOR M74 ROCKET	250
<p>PROBLEM - TPA FILLING METHOD IS SLOW AND CAUSES INEFFICIENT OPERATION.</p> <p>SOLUTION - EVALUATE AND SELECT OPTIMUM FILL EQUIPMENT TO REDUCE FILLING TIME.</p>	
(P244) TITLE - MODERNIZATION OF TRACER LOADING	750
<p>PROBLEM - CURRENT TRACER LOADING TECHNOLOGY UTILIZES CONSIDERABLE LABOR, SLOW/SINGULAR OPERATING TYPE PRESSING MACHINES.</p> <p>SOLUTION - DEVELOP MODERN AUTOMATED MULTIPLE ITEM LOADING EQUIPMENT. HIGH PRODUCTION, LOW MAINTAINABILITY, ECONOMICAL AND RELIABLE EQUIPMENT ADAPTABLE TO NUMEROUS TRACER ITEMS WILL RESULT.</p>	
(1367) TITLE - DEVELOP MFG TECHNOLOGY FOR XM96 CS ROCKET	350
<p>PROBLEM - NEVER PRODUCED AT PBA. MOBILIZATION REQUIREMENT.</p> <p>SOLUTION - PROVIDE MFG TECHNOLOGY. PROVIDE DESIGN CRITERIA FOR IPF.</p>	

COMPONENT -- LOAD

(CONTINUED)

(1701) TITLE - BULK TRANSFER OF CHEMICAL MATERIALS

226 220

PROBLEM - CURRENT TECHNIQUE FOR RETRIEVAL WEIGHING AND TRANSPORTING PYROTECHNIC CHEMICAL CONSTITUENTS ARE ACCOMPLISHED BY LABOR INTENSIVE OPERATION AND ARE UNSAFE.

SOLUTION - AN EFFICIENT MATERIALS HANDLING SYSTEM WILL BE SURVEYED AND DEVELOPED SO THAT EPA/OSHA STANDARDS WILL BE MET.

(2018) TITLE - INJECTION MOLDING TECHNIQUES FOR ACM/CEMS

285

PROBLEM - CURRENT EXPLOSIVE LOADING TECHNIQUES FOR SMALL MUNITIONS USE GRAVITY POURING WHICH REQUIRES PERSONNEL EXPOSURE TO EXPLOSIVES AND RESULTS IN LARGE AMOUNTS OF RISER SCRAP.

SOLUTION - DEVELOP AUTOMATIC PRODUCTION INJECTION MOLDING EQUIPMENT TO LOAD ACM AND CEM ITEMS WHICH WILL VIRTUALLY ELIMINATE EXPLOSIVE RISER SCRAP AND DRASTICALLY REDUCE PERSONNEL EXPOSURE.

(2702) TITLE - EXPLOSIVE HANDLING SYSTEM FOR BOMB LOADING

400 250

PROBLEM - HANDLING OF EXPLOSIVE AND ALUMINUM POWDER AT THE BOMB LOADING PLANTS IS BY BUGGY OR TUB TYPE OF CONTAINERS.

SOLUTION - UTILIZING EXPLOSIVE HANDLING SYSTEM TECH DEVELOPED AT ARRADCOM WILL DESIGN AN AUTOMATED, HAND-OFF HANDLING SYS FOR BOMB LOADING PLANTS.

(2704) TITLE - ELIMINATION OF POST CYCLIC CONDITIONING F/PROJ

450 450

PROBLEM - POST CYCLIC CONDITIONING IS CONSIDERED AS A HIGH COST ELEMENT PER PROJECTILE POURED. THE PRODUCTION LINES ARE NOT OPERATING TO SOLVE THIS PROBLEM.

SOLUTION - EXPERIENCE AT ARRADCOM HAS DEMONSTRATED THAT BASE SEPARATION AND LOOSE CASTS CAN BE ELIMINATED BY PROPER PROCESS CONTROLS OF METAL PART PREHEAT, POURING AND CONTROLLED COOLING. USE EXISTING FACILITIES FOR OPERATIONAL DATA.

(2705) TITLE - LOADING SYSTEM F/IHEP IN MAJOR CALIBER MUNITIONS

450

PROBLEM - DEV OF EXTENDED RANGE + HIGH SETBACK GUN SYS HAVE REINTRODUCED CONCERN REGARDIN PREMATURES. THIS INITIATED A REVEAL OF THE USE OF HIGH EXPLOSIVES SUCH AS COMP B IN THE MUNITIONS TO BE USED IN THESE GUN SYSTEMS.

SOLUTION - WORK IS BEING CONDUCTED ON DEVELOPMENT OF AN INSENSITIVE EXPLO SIVE FOR USE IN MAJOR CALIBER PROJECTILES. THIS PROJECT WILL DESIGN AND BUILD A PROTOTYPE CAST LOAD SYSTEM WITH THE INSENSITIVE EXPLOSIVE USING EXISTING PRODUCTION EQUIPMENT.

COMPONENT -- LOAD	(CONTINUED)	80	81	82	83	84
(2707) TITLE - IMPROVED PROCESS FOR HE CAVITY FORMING						650
PROBLEM - CURRENT GOCO PROCESSES REQUIRE MACHINING OF EXPLOSIVE CAVITIES. THIS IS VERY HAZARDOUS AND MUST BE PERFORMED BEHIND A BARRICADE AND IS VERY COSTLY.						
SOLUTION - REDESIGN HE POURING FUNNEL TO ELIM MACHINING. THIS WILL DRASTICALLY REDUCE COST AS NO BARRICADE IS REQUIRED, EXPENSIVE MACHINERY/MAINT IS ELIMINATED AND SUPPORTING LABOR IS REDUCED.						
(4078) TITLE - UPGRADE SAFETY READINESS AND PRODUCTIVITY OF EXACT MELT POUR				875	275	
PROBLEM - SIGNIFICANT IMPROVEMENT OF MELT POUR FACILITIES IS NOT BEING REALIZED BECAUSE DESIGN APPROACHES FOR COST-EFFECTIVE INTERMEDIATE UPGRADING ARE NOT AVAILABLE.						
SOLUTION - DEVELOP A SERIES OF PROCESS DESIGN CONCEPTS TO IMPROVE SAFETY, REDUCE EXPLOSIVE QUANTITIES, REMOVE PERSONNEL FROM HAZARDOUS AREAS, INCREASE EFFICIENCY AND REDUCE PRODUCTION COSTS. PROVIDE MODULAR DESIGN PKGS F/VARIOUS PROCESSES AND UPGRADING LEVELS.						
(4086) TITLE - REPROCESSING EXPLOSIVE FINES AND DRILL SCRAP						633
PROBLEM - FINELY DIVIDED EXPLOSIVE SCRAP GENERATED IN CAVITY DRILLING AND RISER CRUSHING OPERATIONS IS CURRENTLY BURNED AS WASTE. IT CANNOT BE REPROCESSED IN ITS GENERATED STATE DUE TO HANDLING PROBLEMS AND AGGLOMERATION WHEN INTRODUCED INTO MELT SYSTEMS.						
SOLUTION - DEVELOP A SYSTEM TO SCREEN, INSPECT AND REPROCESS THE FINE EXPLOSIVE INTO FLAKE EXPLOSIVE THAT CAN BE EASILY TRANSPORTED AND DIRECTLY INTRODUCED INTO MELT POUR SYSTEMS.						
(4137) TITLE - AUTO LOADING OF CENTER CORE IGNITERS		205	67	1100		
PROBLEM - LOADING OF THE LONG SLENDER CLOTH BAG IS AN AREA WHICH REQUIRES HIGH LABOR COSTS AND SUBJECTS A LARGE NUMBER OF PERSONNEL TO HAZARDOUS OPERATIONS.						
SOLUTION - DEVELOP EQUIPMENT TO AUTOMATICALLY LOAD THESE IGNITERS.						
(4194) TITLE - IMPROVED PROCESS FOR PRESSING LX-14 EXPLOSIVE CHARGES						500
PROBLEM - PRESENT PROCESS FOR PRESSING LX-14 IS SLOW AND REQUIRES NUMEROUS OPERATIONS WHICH ARE COSTLY.						
SOLUTION - DEVELOP A NEW SIMPLIFIED PROCESS FOR PRESS LOADING LX-14 WHICH STANDARDIZES THE TECHNIQUES ON ALL ITEMS.						

COMPONENT -- LOAD

(CONTINUED)

(4236) TITLE - AUTO LACE JACKETS FOR CENTER CORE CHARGES 612

PROBLEM - THE MANUAL THREADING AND TIGHTENING OF THE LACING IS EXTREMELY TIME CONSUMING AND REQUIRES LABOROUS HIGH COST OPERATIONS WHILE PROVIDING POOR QUALITY PRODUCT.

SOLUTION - DEVELOP AN AUTOMATED/MECHANIZED SYSTEM FOR THE LACING OPERATION.

(4312) TITLE - INJECTION MOLDING FOR PRODUCTION EXPLOSIVE LOADING 261 279

PROBLEM - MELT LOADING OF SMALL EXPLOSIVE ITEMS NORMALLY REQUIRES LARGE SURPLUSES OF MOLTEN EXPLOSIVE TO OBTAIN GOOD FILLING CHAR. SURPLUS RISER. MATERIAL CAN BE TWICE THE AMOUNT LOADED INTO END ITEMS. VERY SMALL ITEMS CANNOT BE EFFECTIVELY MELT LOADED AT ALL.

SOLUTION - DEVELOP AN INJECTION MOLDING SYSTEM FOR FILLING SMALL ITEMS WITH MOLTEN EXPLOSIVE UNDER PRESSURE. DESIGN LOADING FIXTURES TO FORM EXPLOSIVE CHARGES TO FINISHED DIMENSIONS AND REDUCE SURPLUS EXPLOSIVE REQUIREMENTS TO VERY LOW LEVELS.

(4373) TITLE - SILK SCREEN DEPOSITION OF PRIMARY EXPLOSIVES 730

PROBLEM - CURRENT NON-ELECTRIC DETONATOR FACILITIES, EQUIPMENT AND METHODS LACK VERSATILITY. PRESENT PROBLEMS IN QUALITY AND UNIFORMITY OF PRODUCT AND ARE COSTLY IN OPERATION AND MAINTENANCE.

SOLUTION - EVAL NEW IMPROVED OR MODIFIED EQUIPMENT AND TECHNIQUES FOR THE MASS PRODUCTION OF DETONATORS USING SILK-SCREEN TECHNIQUES WITH THE ULTIMATE GOAL OF MODERNIZING PRODUCTION FACILITIES.

COMPONENT -- PACK

(2709) TITLE - AUTOMATED SYSTEM FOR PACKAGING 60MM/81MM CARTRIDGE 1080

PROBLEM - CURRENT PACKAGING EMPLOYS JUNGLE WRAP (WAX DIPPING), A COSTLY TECH. THIS SYS WILL BE REPLACED BY A NEW WATERPROOF SYS (METAL OR PLASTIC CONTAINER) BY FY83/84.

(4253) TITLE - AUTO HIGH RATE UNPACK EQUIP FOR MORTAR PROP CHGS 614

PROBLEM - HANDPACKING ON THE MORTAR PROPELLING CHARGES M204 AND 205 LAP LINE RESULTS IN UNSAFE CONDITIONS AND DAMAGE TO PARTS.

SOLUTION - DEVELOP AUTOMATED EQUIPMENT TO REPLACE HANDPACKING.

\*\*\*\*\*  
\* C A T E G O R Y \*  
\*-----\*  
\*METAL PARTS \*  
\*\*\*\*\*

COMPONENT -- CARTRIDGE CASE

(D028) TITLE - SPIRAL WRAP CARTRIDGE CASE FOR 105MM

400

PROBLEM - PIP PROJECT 1-73-09-0040 IS CURRENTLY WORKING OUT QUALITY PROBLEMS WITH THE USE OF A SPIRAL WRAPPED CARTRIDGE CASE. THIS CASE WILL REPLACE THE DEEP DRAWN CARTRIDGE CASE WHICH IS CURRENTLY MASS PRODUCED.

SOLUTION - DEVELOP TECHNIQUES TO RELIABLY AND EFFICIENTLY HANDLE MATERIAL AND MANUFACTURE CARTRIDGE CASES USING SPIRAL WRAPPING.

COMPONENT -- FORMING/MACHINING

(D005) TITLE - ALTERNATE ASSY FOR SOLDERED AND BRAZED JOINTS

550

PROBLEM - BRAZING AND SOLDERING OPERATIONS REQUIRE PRECISE CONTROL OF CLEARANCES, TEMPERATURES AND FLUXES IN ORDER TO OBTAIN ACCEPTABLE JOINTS.

SOLUTION - ALTERNATE METHODS OF JOINING COMPONENTS WILL BE INVESTIGATED TO REDUCE COST AND ENHANCE RELIABILITY.

(D007) TITLE - ADAPTIVE CONTROL OF DIMENSIONS OF METAL COMPONENTS

550

PROBLEM - WEAR OF CUTTING TOOLS AND GRINDING WHEELS EVENTUALLY PRODUCES OUT OF TOLERANCE DIMENSIONS.

SOLUTION - UTILIZE SENSING DEVICES AND ADAPTIVE CONTROLS TO AUTOMATICALLY COMPENSATE FOR TOOL AND WHEEL WEAR.

(L221) TITLE - ANTI-ARMOR WHD LINES F/XM84

550

PROBLEM - COSTLY AND TIME CONSUMING MANUFACTURING PROCESS FOR MASS PRODUCING SELF-FORGING FRAGMENT LINERS WITH VARYING WALL THICKNESS.

SOLUTION - DETERMINE OPTIMUM PROCESS SUCH AS HYDROFORMING, ELECTROPLATING AND/OR MACHINING. PROVE OUT PROCESS.

(L245) TITLE - FORGING OF ALUMINUM COMPONENTS

250

PROBLEM - FORGINGS FOR OGIVES, BASES, AND FINS ARE IMPACT EXTRUDED WITH LARGE AMOUNT OF MATERIAL LEFT THAT HAS TO BE MACHINED OFF.

SOLUTION - INVESTIGATE USING NET SHAPE FORGING TO ELIMINATE MACHINING OPERATIONS AND MATERIAL WASTE.

(1903) TITLE - DIE CAST TAILCONE + ONE PIECE SKIN FOR BLU-96/B

450 1176

PROBLEM - CURRENT ROLL FORMING EQUIPMENT IS LIMITED TO SIX FEET. BLU-96/B SKIN IS TEN FEET AND IS GROOVED. LIMITED EXPERIENCE EXISTS IN BUILDING A DIE FOR THE BLU-96/B TAILCONE WHICH IS 26 INCHES IN DIAMETER AND WEIGHS IN EXCESS OF 70 LBS.

SOLUTION - DEVELOP A MACHINE THAT WILL ROLL FORM BLU-96/B SKIN. MANUFACTURE ARTICULATE DIE FOR 2000 TON DIE CAST PRESS AND QUALIFY PROTOTYPE FOR IPF.

COMPONENT -- FORMING/MACHINING

(CONTINUED)

(2726) TITLE - LASER CUTTING SLOTS IN HARDENED STEEL STRUCTURES

250

PROBLEM - CURRENT TECHNOLOGY EMPLOYED TO FORM SLOTS IN HARDENED STEEL STRUCTURE OF VARYING THICKNESS IS SLOW AND COSTLY. A MORE COST EFFECTIVE TECHNIQUE IS REQUIRED.

SOLUTION - ADAPT STATE-OF-THE-ART MICROPROCESSOR CONTROLLED LASER CUTTING EQUIPMENT TO PRODUCE CLOSE TOLERANCED ORDNANCE CONFIGURATIONS IN HARDENED STRUCTURES.

(2727) TITLE - PRECISION CONE LATHE FABRICATION

160

PROBLEM - THERE IS NO EFFECTIVE PROVISION FOR MACHINING PRECISION SHAPED CHARGE CONE LINERS IN MEDIUM RANGE PRODUCTION QUANTITIES. YEARLY PRODUCTION RATE OF COPPERHEAD FALLS IN THE MID-RANGE CATEGORY.

SOLUTION - MODIFY A MACHINE TO PROVIDE A BROAD RANGE OF PRECISION SHAPED CHARGE LINERS AT MODERATE VOLUMES AND COMPARATIVELY LOWER COSTS.

(2731) TITLE - ULTRASONIC ASSISTED MACHINING

350

PROBLEM - DIFFICULT TO MACHINE MATERIALS REQUIRE REDUCED FEEDS AND SPEEDS AND INCREASED TOOL WEAR AND BREAKAGE ALL OF WHICH CONTRIBUTES TO INCREASED MACHINING COSTS.

SOLUTION - STUDIES SHOW THAT ULTRASONIC ACTIVATION OF CUTTING TOOLS RESULTED IN REDUCED LOADS AND WEAR WHEN CUTTING DIFFICULT TO MACHINE MATERIALS. ECONOMIC BENEFITS WILL BE ESTABLISHED BY APPLYING THE LAB METHODS TO REAL WORLD MACHINING SITUATIONS.

(2738) TITLE - ACOUSTIC EMISSIONS TO CONTROL METAL WORKING OPS

PROBLEM - IN MANY INSTANCES DEFECTS THAT OCCUR IN THE MFG OF MUNITIONS MPTS ARE NOT SCREENED OUT UNTIL INSPECTION AT THE END OF THE LINE RESULTS IN LOTS OF SCRAP BEFORE PROBLEM IS DETECTED.

SOLUTION - ACOUSTIC EMISSION FROM METAL WORKING OPERATIONS CAN BE MONITORED AND ANALYZED TO CONTROL SPECIFIC PROCESS VARIABLES. FOR EXAMPLE, ACOUSTIC EMISSIONS CAN DETECT GENERATION OF A DEFECT IN METAL WORKING OPERATIONS OR MONITOR TOOL WEAR.

(4369) TITLE - IMPROVED PROJECTILE CAVITY SURFACE

557

PROBLEM - THE FORGING PROCESSES + TECHNIQUES CURRENTLY USED CAN CAUSE DEFECTS + IMPERFECTIONS ON THE CAVITY SURFACE. THIS CONDITION NEEDS CORRECTION TO PREVENT SENSITIVITY PROBLEM THAT CAN OCCUR WITH THE COMP EXPLOSIVE TO BE USED IN HE ROUNDS.

SOLUTION - INVESTIGATE THE VARIOUS OPERATIONS SUCH AS NICK AND BREAK BILLET SEPARATION, SCALE, TOOL WEAR OF FORGE, AND FOREIGN MATTER BUILD-UP. DETERMINE BEST PROCESS CHANGES.

FUNDING (\$000)

PRIOR 80 81 82 83 84  
-----

COMPONENT -- FORMING/MACHINING (CONTINUED)

(4381) TITLE - N/C EQUIPMENT METAL PARTS PRODUCTION

70 245

PROBLEM - NC EQUIP HAS NOT BEEN USED IN AMMO PDN LINES AND ITS INHERENT ACCURACY AND REPEATABILITY IN MACHINING NEW COMPONENTS HAS NOT BEEN ASSESSED.

SOLUTION - USING A THREE-PHASE PROGRAM (1) STUDY FEAS OF ADAPTING AN NC MACHINE TOOL W/SIMULTANEOUS CUTTING CAPABILITY (2) IF FEASIBLE, ADAPT AN NC MACHINE TO TEST CONCEPT (3) PROVE CONCEPT IN PDN ENVIRONMENT.

(4397) TITLE - FABRICATION OF ADVANCED WARHEADS

750

PROBLEM - MANUFACTURING PROCEDURES FOR ADVANCED WARHEADS NEED TO BE ESTABLISHED.

SOLUTION - STUDIES TO ESTABLISH AND OPTIMIZE THE MANUFACTURING PROCESS FOR ADVANCED WARHEADS.

(6716) TITLE - DEV COMP-AID MODEL OF FORMING OPERATIONS FOR ARTILLERY MPTS

157

851

PROBLEM - TRIAL AND ERROR METHODS AND THE ABSENCE OF PROVEN AUTOMATED DESIGN TECHNIQUES FOR TOOLING CAUSE UNEXPECTED FAILURES IN FORMING OPERATIONS AND DELAYS IN STARTUP OF AMMUNITION PRODUCTION LINES.

SOLUTION - DEVELOP ANALYTICAL MODELS AND AUTOMATED TOOL DESIGN METHODS OF CRITICAL METAL FORMING OPERATIONS. TOOL DESIGNS THUS GENERATED WILL BE TESTED IN A PRODUCTION SETTING TO VERIFY THE COMPUTER MODELS. PROVEN MODELS ARE APPLICABLE TO CURRENT AND FUTURE ITE

COMPONENT -- MORTAR

(6759) TITLE - AUTOMATIC TRANSFER-HOT FORMING PRESSES F/MORTAR AMMO

300

PROBLEM - MORTAR METAL PARTS PRODUCTION USES CONVENTIONAL EQUIPMENT AND LABOR INTENSIVE PROCESSES.

SOLUTION - NEW GENERATION HOT FORMERS ARE ANTICIPATED TO BE CONSTRUCTED WITH DESIGN CHARACTERISTICS WHICH WOULD ENABLE AUTOMATIC PROCESSING OF MORTAR METAL PARTS THROUGH THE DRAW WITH NO ADDITIONAL LABOR.

COMPONENT -- PROJECTILE

(1907) TITLE - AUTO GAGING FOR 5 INCH PROJECTILE

625

PROBLEM - CURRENT INSPECTION IS INADEQUATE TO MEET 5 INCH PROJECTILE BODIES REQUIREMENT AND REQUIRES DESIGN CHANGES.

SOLUTION - DEVELOP AUTOMATED ACCEPTANCE INSPECTION SYSTEM FOR 5 INCH 38 AND 5 INCH 54 CALIBER PROJECTILE BODIES.

FUNDING (\$000)

PRIOR 80 81 82 83 84  
-----

COMPONENT -- PROJECTILES

(0006) TITLE - AUTOMATED MATERIAL HANDLING

400 800

PROBLEM - MATERIAL HANDLING IN MUNITIONS METAL PARTS PROCESSING IS A SIGNIFICANT ELEMENT OF COST.

SOLUTION - NEW AUTOMATIC HANDLING DEVICES SUCH AS PROGRAMMABLE ROBOTS WILL BE INVESTIGATED FOR APPLICABILITY TO MUNITIONS COST REDUCTION.

(0010) TITLE - BILLET NICKING IMPROVEMENT

300

PROBLEM - PRESENT PRACTICE OF TORCH NICKING OF STEEL BILLETS FOR PROJECTILE FORGING PRODUCES A PERCENTAGE OF NON-UNIFORM BREAKS THAT RESULT IN FORGING REWORK OR SCRAP.

SOLUTION - INVESTIGATE OTHER FORMS OF NICKING SUCH AS PLASMA ARC, ELECTRON BEAM AND LASER TO IMPROVE QUALITY OF BREAKS.

(0011) TITLE - IMPROVED SWAGING OF ROTATING BANDS

300

PROBLEM - WEST TIRE SETTER BANDING MACHINES ARE COMMONLY USED FOR SWAGING ROTATING BANDS TO PROJECTILE BODIES. THE COMPANY IS NO LONGER IN BUSINESS AND PARTS ARE NOT AVAILABLE FOR IPE IN BASE. NEW LAUTOMATICS AT SCRANTON AND LOUISIANA ARE NOT OPERABLE.

SOLUTION - INVESTIGATE NEW EQUIPMENT DESIGNS TO REPLACE WEST TIRE SETTERS.

(0026) TITLE - SINTERED IRON ROTATING BAND FOR 20MM M220/M246

250 350

PROBLEM - UNDER PIP 1-80-09-0005 AN ALTERNATE MATERIAL, SINTERED IRON, IS TO BE QUALIFIED TO REPLACE THE STANDARD COPPER BAND ON AUTOMATIC CANNON AMMUNITION. CURRENT MANUFACTURING TECHNIQUES PROVIDES FOR EMPLOYMENT OF A COPPER BAND.

SOLUTION - DEVELOP THE NECESSARY MANUFACTURING TECHNIQUES WHICH TAKES INTO ACCOUNT THE SINTERED IRON BAND MATERIAL.

(L139) TITLE - COLD SHEARING OF ALUMINUM SLUGS FOR FORGING

120

PROBLEM - CURRENTLY ALUMINUM BILLETS ARE SAWED TO PROVIDE SLUGS FOR FORGING. THE KERF LOSS IS APPROXIMATELY 0.243 POUNDS PER SLUG.

SOLUTION - ADVANCES IN THE STATE-OF-THE-ART OF COLD SHEARING AND POTENTIAL COST SAVINGS WARRANTS INVESTIGATION OF COLD SHEARING ALUMINUM SLUGS FOR FORGING.

(2728) TITLE - TRAILING FINS BY POWDER METALLURGY FORGING

220

PROBLEM - THE PRESENT METHOD OF FORGING TRAILING FINS IS COSTLY AND TIME CONSUMING IN TERMS OF MACHINING PROCESSES.

SOLUTION - THE USE OF P/M FORGING PROCESSES WILL OBIVIATE THE NEED FOR EXTENSIVE MACHINE OPERATIONS AND WILL REDUCE THE END COST OF THE ITEM.

PRIOR 80 81 82 83 84  
-----

COMPONENT -- PROJECTILES

(CONTINUED)

(2729) TITLE - PROCESS FOR RECYCLING STABALLOY MACHINING CHIPS

600

PROBLEM - STABALLOY CHIPS ARE PYROPHORIC AND MUST BE DISPERSED IN AN INERT MATERIAL TO BE DISPOSED OF BY BURIAL AS A RADIOACTIVE MATERIAL. RECYCLING INTO USABLE METAL WOULD SOLVE DISPOSAL PROBLEMS.

SOLUTION - CONTINUE EFFORT INITIATED IN FY80 W/REDIRECTED FY79 FUNDS. VARIOUS APPROACHES TO CHIP RECYCLING ARE BEING EXPLORED. ONE APPROACH SHOWING MOST ADVANTAGES WILL BE SELECTED FOR FURTHER OPTIMIZATION IN FY83.

(2730) TITLE - METAL FORMING PROCESS (FLOW TURNING)

350 150

PROBLEM - THERE ARE CONSIDERABLE PROBLEMS IN MANUFACTURING SHAPE CHARGE CONES LINERS FOR NEWLY DESIGNED ITEM HEAT MUNITIONS. MANUFACTURING METHODS MUST BE ADAPTED TO A PRODUCTION PROCESS TO SOLVE THESE PROBLEMS.

SOLUTION - TO INVESTIGATE STATE-OF-ART FLOW TURNING TECHNIQUES TO DETERMINE THE OPTIMUM METHOD TO PRODUCE CONES TO THE REQUIRED TOLERANCES.

(4189) TITLE - HIGH FRAGMENTATION STEEL PRODUCTION PROCESS

633 1048 1153 493

PROBLEM - THE CURRENT PRODUCTION PROCESS FOR MANUFACTURING HF1 PROJECTILES IS EXTREMELY EXPENSIVE. PROPRIETARY PRODUCTION PROCESSES DEVELOPED BY PRIVATE INDUSTRY ARE NOT AVAILABLE.

SOLUTION - EXAMINE NEW AND IMPROVED PRODUCTION PROCESSES FOR REDUCTION OF STARTING MULTI-WEIGHT, MACHINING TECHNIQUES, ANNEALING FORGINGS, ONE-HIT HOT NOSING, HEAT TREATING AND FRACTURE TOUGHNESS. WILL COMPLETE A TDP FOR COMPETITIVE PROCUREMENT.

(6738) TITLE - ULTRA-HIGH SPEED METAL REMOVAL, ARTILLERY SHELL

181 297 57

PROBLEM - DUE TO THE LOW METAL REMOVAL RATES OF THE CURRENT CONVENTIONAL MACHINING OPERATIONS, A GREATER NUMBER OF MACHINES ARE REQUIRED TO PRODUCE ARTILLERY PROJECTILES.

SOLUTION - TO ACHIEVE INCREASED METAL REMOVAL RATES ALSO TO REDUCE THE NUMBER OF MACHINES CURRENTLY USED TO PRODUCE PROJECTILES.

COMPONENT -- TOOLING

(D009) TITLE - IMPROVE FORGE TOOL PERFORMANCE

450

PROBLEM - FORGING TOOLS ARE A MAJOR COST ITEM IN SHELL MFG. AND LIFE OF TOOLS HAS A SIGNIFICANT AFFECT ON QUALITY OF FORGINGS AND END PRODUCTS.

SOLUTION - INVESTIGATE USE OF NEW TOOL STEELS AND HARD FACING MATERIALS TO IMPROVE TOOL LIFE AND REDUCE COSTS.

COMPONENT -- TOOLING

(CONTINUED)

(4164) TITLE - ANALYSIS FOR PREDICTING FAILURE OF MFG TOOLING 116

PROBLEM - THE ABILITY TO PREDICT FAILURE OF MACHINE OR COMPONENTS IS NON-EXISTANT. FAILURES ARE COSTLY AND REDUCE PRODUCTION OUTPUT.

SOLUTION - FREQUENCY ANALYSIS WILL IDENTIFY MACHINE PARTS WHICH ARE DEFECTIVE, OVERLOADED, OR NOT OPERATING PROPERLY.

(4322) TITLE - DES CRIT/SYS CHAR OF ELEC CONTROL PROD FAC 795 515

PROBLEM - UNCERTAINTY OF THE EFFECT OF LONG TERM STORAGE DURING PLANT LAYAWAY ON ELECTRONIC CONTROL SYSTEMS AND THE ASSOCIATED IMPACT ON PRODUCTION BASE LEAD TIME.

SOLUTION - ANALYZE DATA CONCERNING DEGRADATION OF ELECTRONIC SYSTEMS DURING PERIODS OF DORMANCY AND DEVELOP CRITERIA FOR LAYAWAY PLANNING AND FUTURE SYSTEM DESIGN.

\*\*\*\*\*  
\* C A T E G O R Y \*  
\*-----\*  
\*POLLUTION ABATEMENT \*  
\*\*\*\*\*

COMPONENT -- CHEMICAL

(1318) TITLE - EST CHEM PROD + FILL CLOSE + LAP TECH F/8VX2 XM736 398 484 216 238

PROBLEM - THE QL PROCESS FOR VX BINARY MFG RESULTS IN LARGE QUANTITIES OF WASTE, AND ORGANIC PHOSPHOROUS COMPOUNDS. PRIOR PROCEDURES FOR DISPOSAL (DEEP WELL) ARE NO LONGER ACCEPTABLE. NEW TECHNIQUES ARE REQUIRED.

SOLUTION - ESTABLISH PROCESSES TO REDUCE WASTE BY-PRODUCTS AND PROVIDE METHODS FOR DISPOSAL OF UNAVOIDABLE WASTE MATERIAL FROM PROCESS MFG.

(2004) TITLE - IMPROVE NEUTRALIZATION F/HAAP SPENT ACID RECOVERY 275

PROBLEM - SODIUM HYDROXIDE IS PRESENTLY USED TO NEUTRALIZE NITRIC ACID IN WEAK ACETIC ACID PROPR TO ITS PRIMARY DISTILLATION AND IN THE FINAL SLUDGE TO "KILL" THE WASTE RDX. A BY PRODUCT OF THIS REACTION IS A LOW GRADE SODIUM NITRATE.

SOLUTION - TO DEV AN ALTERNATIVE MORE COST EFFECTIVE PROCESS F/NEUTRALIZATION OF NITRIC ACID CAUSTICIZING + SLUDGE. CALCIUM HYDROXIDE IS A RECOMMENDED ALTERNATIVE. THE BY-PROD OF THIS REACTION IS CALCIUM NITRATE, A MORE VALUABLE PROD THAN SODIUM NITRATE.

COMPONENT -- CHEMICAL

(CONTINUED)

(4298) TITLE - EVALUATION OF HEXAMINE RECYCLE ON HSAAP B-LINE 472 399

PROBLEM - HAAP'S AMMONIA COLUMN (B-LINE) EFFLUENT CONTAINS HEXAMINE WHICH IS NOT READILY BIODEGRADABLE NOR CHEMICAL DECOMPOSABLE. HEXAMINE IS ALSO CARCINOGENIC USE OF WET OXIDATION IN HAAP'S NEW LWTF WOULD BE QUITE EXPENSIVE TO BUILD AND OPERATE.

SOLUTION - RECYCLE OF THE AMMONIA COLUMN EFFLUENT WOULD CONCENTRATE THE DILUTE HEXAMINE UP TO 30 PERCENT AT WHICH POINT IT CAN BE EITHER REVISED OR INCINERATED.

COMPONENT -- GENERAL

(1354) TITLE - SLUDGE VOLUME REDUCTION AND DISPOSAL PROCESS STUDY 122 156 110

PROBLEM - MCA POLLUTION ABATEMENT FACILITIES UNDER CONSTRUCTION AT PINE BLUFF ARSENAL DISCHARGE INTO A SETTLING LAGOON HAVING A FIVE YEAR CAPACITY BUT NO CLEAN OUT OR SLUDGE DISPOSAL EQUIPMENT. TO EXTEND LAGOON LIFE-SPAN, SLUDGE VOLUME MUST BE MINIMIZED.

SOLUTION - PROVIDE A PROCESS FOR LAGOON SLUDGE CLEAN-OUT + Dewatering for LANDFILL DISPOSAL. VOLUME WILL BE REDUCED BY PRECLARIFICATION + EQUALIZATION TO MINIMIZE CHEMICAL TREATMENT REQUIREMENTS. EVALUATE OTHER TREATMENT CHEMICALS TO REDUCE SLUDGE VOLUME.

(1355) TITLE - MANUFACTURING PLANTS TOXIC EFFLUENT/EMISSION PRETREATMENT 104 222

PROBLEM - THE POLLUTANT DISCHARGE PERMIT PROGRAM REQUIRES THE USE OF BEST AVAILABLE TECHNOLOGY FOR THE TREATMENT OF DESIGNATED TOXIC WASTES BY 1984. PINE BLUFF ARSENAL WASTE TREATMENT FACILITY DOES NOT EMPLOY BEST AVAIL. TECH. FOR THESE POLLUTANTS.

SOLUTION - IDENTIFY MANUFACTURING PLANT PROBLEM EFFLUENTS / EMISSIONS AND HAZARDOUS WASTES AND DEVELOP TREATMENT CRITERIA. UTILIZE BEST AVAILABLE TECHNOLOGY FOR TREATMENT DESIGN CRITERIA. ALSO EVALUATE NEED FOR ADDED EQUIPMENT AND OPERATION CRITERIA.

(1708) TITLE - POLLUTION ABATEMENT CONSERVATION EVALUATIONS 180

PROBLEM - PBA POLLUTION ABATE FAC HEAVY CONSUMER OF VALUABLE RESOURCES-FLOWS FROM PDN AREAS ARE NOT CURRENTLY MONITORED NOR EQUALIZED PRIOR TO TREATMENT CREATING SITUATION WHERE CHEM FEEDERS MUST BE SET A RATE TO TREAT PERIODIC SLUGS W/O NPDES.

SOLUTION - SURVEY OF WATER + CHEM UTIL IN POLLUTION ABATE FAC BE CONDUCTED IDENT CONTROL METHODS TO MINIMIZE FLOW, CHEM UTIL + REDUCE SLUDGE GENERATION. EVAL OF USE OF CONTINUOUS MONITORS IN INFLUENT EQUAL BASIN COULD MINIMIZE/OPTIMIZE CHEM + WATER USAGE

COMPONENT -- GENERAL

(CONTINUED)

(2733) TITLE - ALTERNATIVE TO SECURED LAND FILLS

350

PROBLEM - SECURED LAND FILL ARE COSTLY AND CONTAINERS EVENTUALLY CORRODE AND CREATE NEW CHEMICAL MIXTURES THAT CAN THREATEN THE INTEGRITY OF THE LAND FILL LINERS.

SOLUTION - EVALUATE AND APPLY VARIOUS COST EFFECTIVE TECHNIQUES SUCH AS RECYCLING, INCINERATION SOLIDIFICATION AND STABILIZATION IN LIEU OF SECURED LAND FILL.

(4084) TITLE - OPACITY/MASS EMISSION CORRELATION

121 111

PROBLEM - FORGING OPERATIONS FOR LARGE CALIBER AMMUNITION PRODUCE SMOKE THAT IS REGULATED FOR BOTH OPACITY AND MASS OF THE EMISSIONS.

SOLUTION - AN INEXPENSIVE OPACITY MONITOR MAY BE USED TO ALSO MEASURE THE MASS OF THE EMISSIONS FROM A SMOKE STACK IF PROPERLY CORRELATED.

(4226) TITLE - ON-LINE MONITORS FOR WATER POLLUTANTS

100 379

PROBLEM - AAP'S DISCHARGE MANY MILITARY UNIQUE POLLUTANTS THAT THE SURGEON GENERAL HAS FOUND TO BE MORE TOXIC THAN EXPECTED. AMENDMENTS TO 1977 WATER POLLUTION CONTROL ACT STIPULATE THAT ALL POLLUTANTS BE MONITORED.

SOLUTION - PROGRAM WILL RANK VARIOUS AVAILABLE INSTRUMENTS CAPABLE OF MONITORING TOXIC AND HAZARDOUS POLLUTANTS AT AAP'S, AND CONSIDER COST-BENEFIT RATIOS TO DEVELOP SIMPLE, ECONOMIC INSTRUMENTS TO MONITOR SPECIFIC POLLUTANTS.

(4231) TITLE - IN-PLANT REUSE C. POLLUTION ABATED WATERS

250 464 319

PROBLEM - MORE STRINGENT STANDARDS FOR MILITARY UNIQUE POLLUTANTS. 1985 GOAL OF ZERO DISCHARGE. EXPENSE OF TREATING POLLUTION. CONTINUE THIS REUSE OF TREATED WATER IN OTHER PROCESSES.

SOLUTION - THIS PROJECT CONCENTRATES EFFORT IN RECYCLING OF TREATED WASTE WATER WITH THE ULTIMATE GOAL OF COMPLYING WITH THE ZERO DISCHARGE GUIDELINE.

(4348) TITLE - NOISE POLLUTION ABATEMENT F/SCAMP IN LCAAP

270

PROBLEM - NOISE LEVEL EXCEEDS 85 DBS IN BLDG 1 AT LAKE CITY AAP.

SOLUTION - INSTALL RECOMMENDED ONE SUBMODULE NOISE SUPPRESSION SYSTEM AND EVALUATE ALL OTHER SUBMODULES.

COMPONENT -- GENERAL

(CONTINUED)

(4364) TITLE - ON-LINE BIO SENSORS TO MONITOR MIXED WASTE STREAMS

258 296

PROBLEM - PL92-500 REQUIRES THAT WASTE DISCHARGES BE MONITORED TO ASSURE THAT AQUATIC LIFE ARE PROTECTED FROM TOXIC/HAZARDOUS SUBSTANCES. IN ADDITION, BIOLOGICAL MONITORING WILL SOON BE REQUIRED IN SOME NATIONAL POLLUTION DISCHARGE ELIMINATION SYSTEM PERMITS.

SOLUTION - USE A BIOLOGICAL MONITORING SYSTEM TO EVALUATE TOXIC EFFECTS. FROM CORRELATIONS BETWEEN CHEMICAL CONSTITUENTS IN THE WASTE WATER AND BIOLOGICAL RESPONSES, EXPENSIVE CHEMICAL MONITORING MIGHT BE ELIMINATED.

(4445) TITLE - DETONATOR WASTE TREATMENT

250 350

PROBLEM - WASTE STREAMS FROM DETONATOR AND PRIMER MANUFACTURING OPERATIONS CONTAIN SIGNIFICANT QUANTITIES OF EXPLOSIVES. FEDERAL LAWS MAY REQUIRE DIFFERENT WASTE HANDLING METHODS.

SOLUTION - A TWO FOLD SOLUTION IS PROPOSED. A SURFACTANT PROCESS WILL BE USED TO STABILIZE EXPLOSIVE SEDIMENTATION AND CONTAMINATED SOILS IN THE INTERIM. A PERMANENT ELECTROLYTIC POST TREATMENT TO RENDER THE RESIDUE NON-HAZARDOUS WILL BE DEVELOPED.

(4446) TITLE - ADVANCED AIR EMISSION ABATEMENT

250 350

PROBLEM - AIR EMISSION ABATEMENT MEASURES CURRENTLY IMPLEMENTED MAY NOT BE STATE-OF-THE-ART OR COST EFFECTIVE. MORE ADVANCED TECHNOLOGIES HAVE BEEN DEVELOPED WHICH WARRANT INVESTIGATIONS FOR FUTURE IMPLEMENTATION TO REDUCE COST AND INCREASE EFFICACY.

SOLUTION - AN ENGINEERING ASSESSMENT OF ADVANCED AIR EMISSION ABATEMENT TECHNIQUES AND THEIR APPLICATION TO MILITARY UNIQUE PROCESSES WILL BE CONDUCTED. THE AMMONIA SCRUBBING OF SULFURIC ACID REGENERATION PLANT TAIL GASSES WILL BE EMPHASIZED.

COMPONENT -- PROPELLANTS/EXPLOSIVES

(4225) TITLE - RED WATER POLLUTION ABATEMENT SYSTEM

350 155 160

PROBLEM - RED WATER PRODUCED IN VOLUME FROM THE PURIFICATION OF TNT IS A POLLUTANT FOR WHICH A SATISFACTORY DISPOSAL METHOD DOES NOT EXIST.

SOLUTION - THE FEASIBILITY OF THE SONOCO SULFITE RECOVERY PROCESS FOR THE DISPOSAL OF RED WATER HAS BEEN DEMONSTRATED. THIS PROJECT OPTIMIZES OPERATING PARAMETERS OF CRITICAL COMPONENTS TO SUPPORT AN MCA PROJECT FOR RADFORD AAP.

(4229) TITLE - ADVANCED PINK WATER TREATMENT

460

PROBLEM - CURRENT PINK WATER DISPOSAL TECHNOLOGY THROUGH CARBON ADSORPTION IS HIGH IN COST EVEN WHEN REGENERATION TECHNIQUE IS UTILIZED.

SOLUTION - ALTERNATIVE TECHNOLOGIES ARE AVAILABLE WHICH CAN REDUCE THIS TREATMENT BY 50 PERCENT. IT IS LIKELY THAT A HYBRID SYSTEM WILL BE DEVELOPED THAT CAN BE RETOFTTED TO THE CURRENT SYSTEMS.

COMPONENT -- PROPELLANTS/EXPLOSIVES (CONTINUED)

(4295) TITLE - TERTIARY TREATMENT OF HOLSTON WASTE WATER

85

PROBLEM - FACILITY PROJECT AT HOLSTON REQUIRES TERTIARY TREATMENT TO MEET DISCHARGE STANDARDS FOR NITROBODIES. CARBON ADSORPTION OR A HYBRID TREATMENT SYSTEM IS NEEDED.

SOLUTION - THIS PROJECT WILL COMPLETE PILOT WORK TO ESTABLISH DESIGN CRITERIA AND OBTAIN DATA FOR THE TERTIARY TREATMENT SYSTEM.

(4489) TITLE - ADVANCED POLLUTION ABATEMENT FOR DARCOM FACILITIES

2060

PROBLEM - MUCH WORK HAS BEEN DONE IN THE PROPELLANTS AND EXPLOSIVES PLANTS TO MEET THE POLLUTION ABATEMENT STANDARDS. HOWEVER, ALL OF THE GOALS HAVE NOT YET BEEN MET.

SOLUTION - DEVELOP TECHNOLOGY TO DISPOSE OF WASTEWATER TREATMENT SLUDGE, TO PROVIDE TERTIARY TREATMENT OF HAAP WASTEWATER, TO TREAT PINK WATER, AIR EMISSION AND DETONATOR WASTE, AND TO PROVIDE ENVIRONMENTAL IMPROVEMENTS FOR NITRATE ESTERS.

COMPONENT -- RECYCLE

(2030) TITLE - REMOVAL/REUSE OF NC FINES

150

PROBLEM - IN NC MFG PROCESS, EFFLUENT AFTER CENTRIFUGATION IS DIR INTO PITS WHERE NC FINES ARE ALLOWED TO SETTLE F/REUSE. CONCENTRATION OF SUS FINES CONTINUALLY BUILD UP, RESULTS IN EXCESS USE OF CENTRIFUGES TO REMOVE + MAINTAIN FINES AT TOLERABLE LEVEL F/REUSE

SOLUTION - EVAL USE OF KNOW FLOCCULANTS + SURFACTANTS TO PROMOTE SETTLING OF NC FINES, EVAL OF EFFECT OF FLOCCULANT ON SETTLED FINES WHICH ARE REBLENDED+USED IN VAR PROP FORMULATIONS. COMPAT+STAB + STATIC PER TEST + ECON OF DISPOSAL VS REUSE WILL BE DETERMINED

(4011) TITLE - POLLUTION ABATE FOR RECYCLE OF MET-ILLUMINANTS

201

PROBLEM - SCRAP PYROTECHNIC COMPOSITION IS DISPOSED BY BURNING CAUSING AIR POLLUTION. ALSO POWDERED MANESIUM IS LOST AND IT IS A CRITICAL MATERIAL IN SHORT SUPPLY.

SOLUTION - NAVY AT CRANE INDIANA HAS COMPLETED R+D WORK ON RECOVERING AND RECYCLING OF POWDERED MAGNESIUM. SIGNIFICANT COST SAVINGS ARE PROJECTED. THIS PROJECT WILL CONDUCT THE REQUIRED PILOT WORK TO SUPPORT FACILITY DESIGN.

(4033) TITLE - CAUSTIC RECOVERY FROM SODIUM NITRATE SLUDGE

153 286

PROBLEM - HOLSTON IS CURRENTLY LOSING \$80 FOR EACH TON OF SODIUM NITRATE BY-PRODUCT SOLD. SODIUM NITRATE IS EXTREMELY DIFFICULT TO DISPOSE OF BECAUSE OF COMPETITION FROM OTHER FERTILIZERS ON THE MARKET.

SOLUTION - CONVERT SODIUM NITRATE INTO SODIUM HYDROXIDE FOR REUSE IN SPENT ACID RECOVERY OPERATIONS AT HOLSTON. A SUBSTANTIAL COST BENEFIT RESULTS BY REDUCING AMOUNT OF NEW SODIUM HYDROXIDE SOLUTION TO BE PURCHASED.

FUNDING (\$000)

PRIOR 80 81 82 83 84

COMPONENT -- RECYCLE

(CONTINUED)

(4344) TITLE - EST WASTE DISPOSAL TECH FOR M687 BINARY PROJ FAC

108 200 388

PROBLEM - LARGE QUANTITIES OF SOLID WASTES ARE GENERATED DURING DF MFG. THERE IS NO ACCEPTABLE DISPOSAL METHOD. DRUM STORAGE IS NOT FEASIBLE AND LANDFILL MAY REQUIRE SPECIAL PREPARATION.

SOLUTION - DEVELOP PROCEDURES FOR DECREASING THE AMOUNT OF SOLID WASTE GENERATED. RECOVER WASTES IN THE FORM OF LIQUID HCL WHICH CAN BE USED IN THE CENTRAL LMT FACILITY AND RECYCLE STILL BOTTOMS WHICH WILL REDUCE SOLID WASTES BY 80 PERCENT.

\*\*\*\*\*  
\* C A T E G O R Y \*  
\*-----\*  
\*PROPELLANTS \*  
\*\*\*\*\*

COMPONENT -- BENITE

(4210) TITLE - DRY CUTTING OF ENERGETIC MATERIALS

450 52

PROBLEM - BENITE STRANDS ARE CUT TO REQUIRED LENGTHS USING A MILLING MACHINE WITH TWO CIRCULAR SAWS. THIS IS UNDULY COSTLY BECAUSE OF EXCESSIVE HANDLING, AND ADDITIONAL DRYING AND INSPECTION OPERATIONS.

SOLUTION - INITIATE HIGH PRESSURE WATER IN FORM OF A FINE JET STREAM TO CUT BENITE STRANDS. THIS WILL REDUCE THE NUMBER OF OPERATIONS, ELIMINATE BUNDLING, TYING/UNTYING OPERATIONS, AND REDRYING WILL BE MINIMIZED.

COMPONENT -- GENERAL

(2038) TITLE - LOVA PROPELLANT MANUFACTURING PROCESS

700 900

PROBLEM - VUL OF PROP TO VAR ATTACK FORCES CONTRIB MAJOR PORTION OF PROBABILITY OF LOSING A FIRING VEHICLE. VUL OF BULK PROPELLANT IN COMPLETE ROUND ASSEMBLY, STORAGE OR TRANSPORT IS ALSO A PROBLEM. THIS CHARAC IS INHERENT IN CURRENT MULTIBASE FORMULATION

SOLUTION - CLASS OF PROP UTIL NITRAMINES REDUCES PROB TO ACCEPT LEVELS. A PROCESS F/HFG OF LOVA PROP + AN INERT BINDER BE DEV. PILOT SCALE PROCESS EQUIP BE ASSEMBLED TO PROV AN ENERGETIC PROP IN OPTIMUM GEOMETRIC CONFIG F/BALLISTIC EVAL IN SPEC APPLICATIONS.

(4145) TITLE - CONTROL DRYING IN AUTO SB AND BALL PROP MFG

552 272

PROBLEM - OFF-LINE ANALYSIS FOR MOISTURE AND VOLATILES MAKES IT DIFFICULT TO CONTROL A CONTINUOUS DRYING OPERATION SINCE THE TIME REQUIRED FOR ANALYSIS IS LONG COMPARED TO THE RESIDENCE TIME FOR THE PROPELLANT IN A CONTINUOUS DRYER.

SOLUTION - USE PRODUCT TEMPERATURE AND/OR ON-LINE ANALYZERS AND FLOW METERS AS A BASIS FOR IMPROVED CONTROL OF A CONTINUOUS DRYING OPERATION AND REDUCE THE AMOUNT OF OFF-LINE ANALYSIS REQUIRED.

PRIOR 80 81 82 83 84  
-----

COMPONENT -- GENERAL

(CONTINUED)

(4273) TITLE - AUTO PRODUCTION OF STICK PROPELLANT

850 270

PROBLEM - PRESENT BATCH TECHNIQUES FOR STICK PROPELLANT MFG INVOLVE MUCH HAND LABOR THEREBY RESULTING IN LIMITED PRODUCTION CAPACITY, HIGH COST, AND HAZARD EXPOSURE.

SOLUTION - INSTALL AND EVALUATE PROTOTYPE EQUIPMENT TO AUTOMATICALLY PRODUCE RACKED SOLVENT-TYPE STICK PROPELLANT, WHICH WILL BE CUT BY FLUID JET CUTTER. THIS PROCESS WILL OPERATE WITH EXISTING 12 INCH PRESS AND PRESS BAY.

COMPONENT -- MULTI BASE

(D023) TITLE - CONTINUOUS PRODUCTION OF NEW PROPELLANTS ON CAMBL

250 600

PROBLEM - VARIOUS HIGH ENERGY AND LOVA GRANULAR AND STICK MULTI BASE PROPELLANTS ARE BEING DEVELOPED BATCH FA CILITIES FOR MULTI BASE PROPELLANTS HAVE A CONSTRAINED CAPACITY. A NEW CAMBL IS BEING BUILT BUT HASNT BEEN PROVEN ACCEPTABLE ON THE NEWER PROPELLANTS.

SOLUTION - ADAPT RECENTLY DEVELOPED CAMBL PROCESS TO DEMONSTRATE THE MASS PRODUCIBILITY OF THE NEW PROPELLANTS. THIS WILL INSURE A PRODUCTION BASE FOR THE NEW FORMULATIONS AND PREVENT HAVING TO USE AND/OR BUILD INEFFICIENT BATCH FACILITIES.

(4462) TITLE - MODERNIZED FAD FOR MULTI-BASE PROPELLANTS

1283 850

PROBLEM - FORCED AIR DRYING PROCESS AND FACILITIES MUST BE MODIFIED TO REDUCE THE POLLUTION EMISSIONS AND AT THE SAME TIME RECOVER VALUABLE PROPELLANT MATERIAL.

SOLUTION - DEVELOP RECOVERY EQUIPMENT TO REDUCE POLLUTION EMISSIONS AND PROVIDE MORE EFFICIENT HEATING PLATE COILS COUPLED WITH LOWER AIR VELOCITIES.

COMPONENT -- NITROCELLULOSE

(D019) TITLE - PROCESS FOR MFG OF CELLULOSE NITRATE SHEETSTOCK

300 600

PROBLEM - THE ARMY INTENDS TO PROCURE THE MFG RIGHTS TO THE UK MORTAR ROUND WHICH USES CN SHEETSTOCK. THE CURRENT PRODUCTION METHOD OF CASTING THE CN INTO BLOCKS AND SLICING THE BLOCKS INTO SHEETS IS TIME CONSUMING AND LABOR INTENSIVE.

SOLUTION - INVESTIGATE OTHER METHODS OF MANUFACTURE, DETERMINE FEASIBILITY AND PROVIDE EQUIPMENT TO AUTOMATE THE SHEETSTOCK MANUFACTURING PROCESS.

COMPONENT -- NITROCELLULOSE

(CONTINUED)

(4341) TITLE - IMPROVED NITROCELLULOSE PURIFICATION

1642 583 765

PROBLEM - EXISTING NITROCELLULOSE PURIFICATION FACILITIES WERE BUILT IN EARLY 1940'S AND ARE IN DETERIORATED CONDITION. THE PROCESS USED DATES BACK TO WW1 AND CONSUMES LARGE QUANTITIES OF ENERGY AND WATER.

SOLUTION - SELECT AND DEVELOP A NITROCELLULOSE PURIFICATION PROCESS TO BE USED IN THE MODERNIZATION PROGRAM WHICH IS MORE ENERGY AND WATER EFFICIENT. THE METHOD SELECTED IS BASED ON THE SWISS CONICELL PROCESS AS A RESULT OF THE FY77 EFFORT.

(4426) TITLE - MODERN CELLULOSE SHREDDER

250

PROBLEM - THE PRESENT CELLULOSE SHREDDER IS 40 YEARS OLD AND REQUIRES EXCESSIVE MAINTENANCE. THE MAJORITY OF THE MAINTENANCE ACTIONS ARE CONCENTRATED IN THREE AREAS - ADDING OIL TO THE BEARINGS, SETTING THE BED KNIFE, AND UNPLUGGING THE SHREDDER.

SOLUTION - OBTAIN A SUITABLE SHREDDER FOR USE ON THE CONTINUOUS NC LINE. DETERMINE IF SHREDDING CAN BE ACCOMPLISHED PRIOR TO DRYING. IN THIS WAY, THE PULP WOULD BE MOIST AND COOL DURING SHREDDING, DECREASING THE WEAR ON THE BLADES.

COMPONENT -- NITROGUANIDINE

(4059) TITLE - NQ CRYSTALLIZATION FOR CONTINUOUS PROP LINES

250

568

544

PROBLEM - NITROGUANIDINE PRODUCED ON THE NEW LINE AT SUNFLOWER AAP IS EXPECTED TO HAVE A DIFFERENT PARTICLE SIZE DISTRIBUTION THAN THAT OF PREVIOUS SUPPLIER. THIS MAY CREATE PROCESSING PROBLEMS IN THE NEW CONTINUOUS AUTOMATED MULTI-BASE LINE (CAMBL) PROCESS.

SOLUTION - THIS PROJECT IS TO QUALIFY THE NITROGUANIDINE PRODUCED AT SUNFLOWER AAP ON THE CAMBL PROCESS AT RADFORD AAP AND DETERMINE IF THERE WILL BE ANY SERIOUS PROCESSING PROBLEMS.

(4061) TITLE - NITROGUANIDINE PROCESS OPTIMIZATION

260

953

895

PROBLEM - A NITROGUANIDINE FACILITY IS UNDER CONSTRUCTION ATSAAP AND IS TO BE OPERATIONAL IN FY80. IT UTILIZES PROCESSES NOT PREVIOUSLY USED COMMERCIALY AND IT CONTAINS MANY RECIRCULATION AND SUPPORT LOOPS, THE OPERATION OF WHICH ARE STRONGLY INTERDEPENDENT.

SOLUTION - CONDUCT PROCESS IMPROVEMENT PROCEDURES USING NITROGUANIDINE SUPPORT EQUIPMENT (NSE) INSTALLED UNDER PROJECT 5752632, AND APPLY EVOLUTIONARY OPERATION (EVOP) TO THE NITROGUANIDINE FACILITY BEING CONSTRUCTED AT SUNFLOWER APP.

-----

COMPONENT -- NITROGUANIDINE

(CONTINUED)

(4427) TITLE - ON-LINE ANALYZERS FOR NITROGUANIDINE PLANT

388

PROBLEM - A NITROGUANIDINE MFG FACILITY IS BEING CONSTRUCTED AT SUNFLOWER AAP. MMT 5 78 4447 INDICATED THE FEASIBILITY OF AUTOMATED ON-LINE INSTRUMENTATION FOR PROCESS STREAM CHEMICAL ANALYSIS. HOWEVER THE RELIABILITY HAS NOT BEEN DEMONSTRATED.

SOLUTION - INSTALL AND EVALUATE AN ON-LINE ION CHROMATOGRAPH, A GAS CHROMATOGRAPH, AND A SPECTROPHOTOMETER IN THE NG SUPPORT EQUIPMENT WHICH IS TO BE OPERATED DURING FY82 UNDER MMT 5 8X 4061, NG PROCESS OPTIMIZATION.

COMPONENT -- SINGLE BASE

(4027) TITLE - SOLVENT RECOVERY/DRYING OF SINGLE BASE PROPELLANTS

337

PROBLEM - PRESENTLY SOLVENT RECOVERY, WATER DRY, AND AIR DRY OPERATIONS ARE ACCOMPLISHED IN 3 SEPARATE TANKS, ONE TANK IS USED FOR EACH OPERATION. THESE OPERATIONS ARE BOTH LABOR AND ENERGY INTENSIVE AND GENERALLY INEFFICIENT.

SOLUTION - COMBINE THE 3 SEPARATE OPERATIONS INTO ONE COMBINED OPERATION TO TAKE PLACE IN ONE MODIFIED SOLVENT RECOVERY TANK. THIS APPROACH WILL RESULT IN A SIGNIFICANT SAVINGS IN BOTH LABOR AND ENERGY.

COMPONENT -- SOLVENTLESS

(4044) TITLE - FINAL ROLL MILL FOR SOLVENTLESS PROPELLANT

675

PROBLEM - CURRENT METHOD FOR MANUFACTURE OF SOLVENTLESS DOUBLE BASE PROPELLANT CARPETROLLS IS LABOR INTENSIVE, SLOW AND EXPOSES OPERATING PERSONNEL TO POTENTIALLY HAZARDOUS MANUAL OPERATIONS.

SOLUTION - MODIFY ROLL MILL (DEVELOPED FOR MORTAR PROPELLANT) TO PRODUCE SOLVENTLESS, DOUBLE BASE PROPELLANT CARPET ROLLS. DIRECT BENEFITS INCLUDE REDUCED COST AND IMPROVED SAFETY.

\*\*\*\*\*  
\* C A T E G O R Y \*  
\*-----\*  
\*QUALITY CONTROL/TESTING \*  
\*\*\*\*\*

COMPONENT -- INSPECTION

(4103) TITLE - AUTO LINK INSPECTION EQPT SYSTEM (ALIES)

319 542

PROBLEM - CURRENT MANUAL INSPECTION METHODS FOR SMALL ARMS AMMUNITION LINKS ONLY PROVIDES FOR A SAMPLING OF LESS THAN ONE PERCENT OF OUTGOING LINKS. NON- CONFORMING LINKS CAUSE COSTLY LOADING MACHINE JAMS.

SOLUTION - THIS PROJECT WILL DEVELOP AND BUILD AN AUTOMATED LINK INSPECTION SYSTEM. THE SYSTEM WILL TEST AND INSPECT CRITICAL AND MAJOR FEATURES OF EACH M13 LINK PRODUCED.

FUNDING (\$000)

PRIOR 80 81 82 83 84

COMPONENT -- INSPECTION

(CONTINUED)

184

(4276) TITLE - PRODUCTION OPTICAL INSP SYSTEM 155MM KNURL

PROBLEM - INADEQUATE KNURL BETWEEN THE ROCKET MOTOR BODY AND WARHEAD BASE CAUSES FLIGHT FAILURE.

SOLUTION - AN AUTOMATIC INSPECTION TESTING TECHNIQUE INCORPORATED IN PRODUCTION LINE TO INSURE ADEQUACY OF THE KNURL.

124

(4357) TITLE - FLUX LEAKAGE INSPECTION SYSTEM FOR M483

PROBLEM - THERE IS NO NONDESTRUCT INSP METHOD WITH FLOW DETECTION RELIABILITY ESTAB F/M483. A MAGNETIC FLUX LEAKAGE DEVICE PURCHASED F/LOUISIANA AAP DEMONSTRATED FEAS BUT COST OF OPERATION MUST BE DETERMINED.

SOLUTION - DESIGN DEVELOP AND FABRICATE A PROTOTYPE MFL INSP SYS + EVALUATE RELIABILITY + OPERATING COST COMPARED TO ULTRASONIC INSPECTION SYSTEMS.

197

(4359) TITLE - IMPROVE PROCESS TECHNOLOGY F/INSPECTION OF CLOTH

PROBLEM - REDUCE TIME AND COST OF VISUAL INSPECTION OF CLOTH USED IN PROPELLANT BAGS, FLASH REDUCERS, ADDITIVE LINERS AND IGNITER PADS.

SOLUTION - IMPLEMENT EQUIP PROVEN FEASIBLE. PROCURE + INSTALLATION OF MOD STATE-OF-ART SENSORS THAT WILL MARK LOCATION OF CLOTH DEFECTS DURING SLITTING OPERATION. CLOTH WILL BE REMOVED + DISCARDED PRIOR TO SUBSEQUENT SEWING OPERATIONS.

130

(4471) TITLE - CONICAL SURFACE INSPECTION

PROBLEM - NO SATISFACTORY AUTOMATED INSPECTION EQUIPMENT IS KNOWN TO ACCOMPLISH THE VARIOUS CONICAL SURFACE INSPECTIONS FOR CONVENTIONAL AND ADVANCED SHAPED CHARGE LINERS.

SOLUTION - PROVIDE AN AUTOMATED INSPECTION SYSTEM COMPATIBLE WITH PROPOSED CONVENTIONAL AND SHAPED CHARGE TECHNOLOGY PROGRAMS. SPECIFICALLY FOR CONICAL SURFACE MEASUREMENTS.

COMPONENT -- NON-DESTRUCTIVE TESTING

(L251) TITLE - OFF-LINE MOISTURE TEST FOR DETONATORS

PROBLEM - PRESENT METHOD IS LABOR INTENSIVE. TOO MANY BAD DETONATORS ARE PRODUCED PRIOR TO DISCOVERING PROBLEMS. TEST REQUIRES STORAGE OF LARGE QUANTITIES OF DETONATORS.

SOLUTION - DEVELOP PROTOTYPE HELIUM LEAK DETECTOR SYSTEM WHICH WILL REDUCE TIME FOR TEST. QUICKER TURNOVER WILL REDUCE STORAGE REQUIREMENTS.

175 350

COMPONENT -- NON-DESTRUCTIVE TESTING (CONTINUED)

(4131) TITLE - SHELL HOLOGRAPHIC INSPECTION AND EXAMINATION LINE DEVICE 163

PROBLEM - THERE IS NO COMPLETE AUTOMATIC NONDESTRUCTIVE INSPECTION SYSTEM FOR TESTING SHELLS AT 100 PERCENT PRODUCTION RATE.

SOLUTION - DEVELOP A PRODUCTION PROTOTYPE HOLOGRAPHIC SYSTEM TO AUTOMATICALLY INSPECT ENTIRE 155MM M483A1 MPT PROJECTILES.

(4473) TITLE - AUTO LEAK DETECTION OF WP MUNITIONS 825

PROBLEM - THE CURRENT METHOD OF HEATING THE WHITE PHOSPHOROUS MUNITIONS TO CHECK FOR LEAKS IS LABOR INTENSIVE AND IS NOT UNIFORM FOR ALL ROUNDS.

SOLUTION - PROVIDE A PROTOTYPE AUTOMATED IN-LINE LEAK DETECTION SYSTEM BASED ON QUANTITATIVE FLAME PHOTOMETRY. THE SYSTEM WILL CONSIST OF TWO HEATING STAGES, A SAMPLING WHEEL, LEAK DETECTOR AND HANDLING SYSTEM.

COMPONENT -- SIMULATION

(2856) TITLE - SHOCK IMPULSE HYDROSTATIC TESTING 205

PROBLEM - BALLISTIC ACCEPT TEST OF METALLIC CARTRIDGE CASES UTILIZES 100 SAMPLE ITEMS LOADED INTO COMPLETE ROUNDS + FIRED AT A PG. THIS TEST CONSTITUTES APPROX 50 PERCENT OF ALL BALLISTIC ACCEPT TEST DONE ON ENTIRE ROUND REQUIRED TO PRODUCT ROUND.

SOLUTION - A SHOCK IMPULSE HYDROSTATIC PRESSURE TESTER DEV TO TEST COMPONENT CARTRIDGE CASE IN-PLANT W/O NEED OF ASSEMBLING INTO A FULL-UP ROUND WHILE STILL SIMULATING INTERIOR BALLISTIC PULSE WILL MINIMIZE EXPENSE OF TESTING BALLISTICALLY.

COMPONENT -- X-RAY

(4454) TITLE - AUTOMATIC INSPECTION DEVICE EXPLOSIVE CAST IN SHELL 2076 1298 1885 318

PROBLEM - THE PRESENT METHOD OF INSPECTION LOADED PROJECTILE UTILIZES A STANDARD RADIOGRAPHIC FILM METHOD. LABOR AND MATERIAL (FILM) ARE COSTLY. DETERMINATION OF CRITICAL DEFECT IS SUBJECT TO HUMAN JUDGEMENT, FATIGUE, AND ERROR.

SOLUTION - DEVELOP PROTOTYPE SYSTEM USING A MINI-COMPUTER TO ANALYZE X-RAY IMAGES TO AUTOMATICALLY ACCEPT OR REJECT GROUPS OF HE FILLED PROJECTILES. DEVELOP A PROTOTYPE FILMLESS REAL-TIME AUTOMATED INSPECTION SYSTEM.

\*\*\*\*\*  
\* C A T E G O R Y \*  
\*-----\*  
\*SAFETY \*  
\*\*\*\*\*

MMT FIVE YEAR PLAN  
RCS DRCMT 126

FUNDING (\$000)

PRIOR 80 81 82 83 84  
-----

COMPONENT -- GENERAL

(2021) TITLE - FIRE SUPPRESSANT SYSTEM F/MELT-POUR + TNT REALTOR

175 150

PROBLEM - THE USE OF WATER IN FIRE SUPPRESSANT SYS COULD CAUSE POTENTIALLY DANGEROUS SITUATIONS IN MELT POUR VESSEL AND TNT REACTORS.

SOLUTION - EXPLORE THE USE OF INERT GASES AS FIRE SUPPRESSANTS IN THE MELT POUR AND TNT PRODUCTION AREAS.

(2741) TITLE - ADVANCE LIGHTNING PROTECTION TECHNIQUES TO AAPM'S

150

PROBLEM - AS THE ELECTRONICS ADOPTED IN THE DESIGN OF AAPM'S BECOMES MORE SOPHISTICATED AND COSTLY, THE NEED FOR QUICK AND RELIABLE LIGHTNING PROTECTION INCREASES.

SOLUTION - IMMEDIATE EVALUATION OF AUSTRALIAN (E.F. AUSTRALASIA) LIGHTNING PROTECTION SYSTEM AND SUBSEQUENT STATE OF THE ART ADVANCEMENT.

(4071) TITLE - EXPLOS PREVENTION IN DRY DUST COLLECTION SYSTEMS

450

PROBLEM - POTENTIALLY HAZARDOUS CONDITIONS EXIST IN DRY DUST COLLECTION SYSTEMS THROUGHOUT THE MUNITIONS PRODUCTION BASE. PRESENT DATA ON DETONATION CHARACTERISTICS OF EXPLOSIVE, PROPELLANT OR PYROTECHNIC DUST ARE INCOMPLETE/INADEQUATE TO IMPROVE SAFETY.

SOLUTION - DEVELOP DATA TO ESTABLISH SAFE OPERATING PARAMETERS FOR DUST COLLECTION SYSTEMS. UTILIZE THESE DATA TO DEVELOP FAIL-SAFE COLLECTION SYSTEM DESIGNS WHICH PREVENT DUST EXPLOSIONS BY EMPLOYMENT OF PROPER VENTING, LIMITING IGNITION ENERGY, ETC.

(4291) TITLE - BLAST EFFECTS IN THE MUNITIONS PLANT ENVIRONMENT

359

1285 100

PROBLEM - MOST OF THE DESIGN EFFORT IS IN THE AREA OF LACE REINFORCED STRUCTURES FOR CLOSED IN AREAS TO AN EXPLOSION. WE MUST ATTEMPT TO UTILIZE COM CONSTRUCTION MATERIAL.

SOLUTION - TO STUDY CHARACTERISTICS OF THE BLAST ENVIRONMENT AND DETERMINE THE RESPONSE OF THE VARIOUS STRUCTURAL MATERIALS AND ELEMENTS SUBJECTED TO THESE LOADINGS.

COMPONENT -- LAP

(4374) TITLE - EXPLOSIVE SAFETY SHIELDS

197

90

PROBLEM - ACRYLIC MATL IS USED AS A PROTECTIVE SHIELD ON LOADING LINES WHERE LOADING OF SMALL QUANT OF HIGHLY SENSITIVE EXPLOSIVE OCCURS. NO DATA ON BLAST CAP OF THE MATL IS AVAIL + WORK MUST BE DONE ON A CASE-BY-CASE BASIS.

SOLUTION - DETERMINE BLAST CAP OF ACRYLIC MATLS + PREP DESIGN GUIDANCE F/FUTURE USE. TECH REPORTS FOR DESIGN GUIDANCE OF THIS TYPE OF PROTECTIVE SHIELDS WILL BE DEV TO PRECLUDE CASE-BY-CASE METHOD NOW USED.

COMPONENT -- LAP

(CONTINUED)

(4429) TITLE - IMPROVED SAFETY OF SCALE WEIGHING EQUIPMENT

379

PROBLEM - ELECTRONIC CONTROLS FOR WEIGHING SYSTEMS DO NOT MEET THE NATIONAL ELECTRICAL CODE STANDARDS AND OPERATE PRESENTLY UNDER EXCEPTIONS TO THE CODE.

SOLUTION - SCALE TRANSDUCERS WILL BE STUDIED AND SPECIFICATIONS OF THE VARIOUS COMPONENTS WILL BE REVIEWED. COMMERICALLY AVAILABLE COMPONENTS WILL BE CONFIGURED TO ACHIEVE AN INTRINSICALLY SAFE TRANSDUCER.

COMPONENT -- PROPELLANTS/EXPLOSIVES

(1600) TITLE - SAFETY CONVEYORS IN AAP'S

185 90

PROBLEM - PREVENT PROPAGATION BETWEEN AMMUNITION ITEMS AND IN-PROCESS MATERIALS ON CONVEYORS.

SOLUTION - PROPAGATION BETWEEN AMMUNITION ITEMS AND IN-PROCESS MATERIALS MAY BE PREVENTED THROUGH THE USE OF CERAMIC TYPE CURTAINS.

(2701) TITLE - NEAR FIELD BLAST PARAMETERS OF ENERGETIC MATERIALS

120 100

PROBLEM - BLAST RESISTANT BARRICADES DESIGNED IN ACCORD W/TMS-1300 ARE BASED ON KNOWN WEIGHTS OF FREE-AIR BURSTS OF SPHERICAL TNT. IN THE REGION CLOSE TO AN EXPLOSION, THE CHARGE SHAPE AFFECTS BLAST OUTPUT, THEREFORE, THE SPHERE USED FOR DESIGN PURPOSES IS ALTERED

SOLUTION - DETERMINE, THROUGH TESTING, RELATIVE EFFECT VARIOUS CHARGE GEOMETRICS HAVE ON AIRBLAST OUTPUT. THIS #SHAPE EFFECT# CAN THEN BE INTRO ANALYTICALLY TO DETERMINE THE PROPER DESIGN WEIGHT TO USE FOR A GIVEN SITUATION.

(4285) TITLE - TNT EQUIV TESTING FOR SAFETY ENGINEERING

1595 408 441 251

PROBLEM - PRESENT CRITERIA FOR BLAST RESISTANT STRUCTURES IS IN TERMS OF SURFACE BURST OF HEMISPHERICAL TNT. IN STRUCTURAL DESIGN, TO PROTECT FROM THE OUTPUT OF OTHER ENEGETICS, THE DESIGNERS MUST HAVE DATA PERTINENT TO THE MATERIAL IN QUESTION.

SOLUTION - BY TESTING TO GENERATE PEAK PRESSURE AND POS IMPULSE DATA FROM BLAST MEASUREMENTS OF HIGH ENERGY MATERIALS IS GENERATED. THESE RESULTS ARE COMPARED WITH THE BLAST OUTPUT OF HEMISPHERICAL TNT TO DETERMINE THE TNT EQUIVALENCY OF THE MATERIAL.

(4288) TITLE - EXPLOSIVE SAFE SEPARATION AND SENSITIVITY CRITERIA

2796 767 720

PROBLEM - DATA IS REQUIRED TO UPGRADE PROCESSES AND MATERIAL FOR THE MAXIMUM SAFETY OF PERSONNEL AND EQUIPMENT AGAINST EXPLOSION PROPOGATION.

SOLUTION - TESTS WILL BE DESIGNED AND CONDUCTED FOR EXPLOSIVES AND END ITEMS TO DETERMINE THE SAFE SEPARATION DISTANCE AND THE EXPLOSIVE DEPTH ON CONVEYORS.

MMT FIVE YEAR PLAN  
RCS DRCMT 126

FUNDING (\$000)

PRIOR 80 81 82 83 84  
-----

COMPONENT -- PROPELLANTS/EXPLOSIVES (CONTINUED)

(4421) TITLE - PREVENT EXPLOSIONS FROM ELECTROSTATIC DISCHARGES 200

PROBLEM - ELECTROSTATIC DISCHARGES HAVE CAUSED EXPLOSIONS IN MUNITION PLANTS ENGAGING IN LOADING, SCREENING AND AIR-VEYING OPERATIONS. THE EXTENT OF ELECTROSTATIC CHARGE ACCUMULATIONS ON VARIOUS ENERGETIC MATERIALS HAS NOT BEEN DETERMINED.

SOLUTION - INSTRUMENTATION WILL BE USED TO MONITOR ELECTROSTATIC CHARGES AND THE EFFECTS OF HUMIDITY, PARTICLE SIZE, TEMPERATURE AND MASS FLOW RATE WILL BE DETERMINED. FROM THIS DATA, AN APPROACH TO ELIMINATE ELECTROSTATIC CHARGES WILL BE POST ULATED.

(4453) TITLE - DETERMINE PROPAGATION DISTANCE F/ENERGETIC MATERIA 200

PROBLEM - THE EXISTING SAFETY MANUAL (AMCR 385-100) HAS BECOME ANTIQUATED BY RECENT ADVANCES IN WEAPONS TECHNOLOGY. THERE IS A NEED TO UPGRADE ACCIDENTAL DETONATION SUPPRESSION CRITERIA.

SOLUTION - A SERIES OF PROPAGATION SUPPRESSION CRITERIA TESTS ON VARIOUS ENERGETIC MATERIALS WILL BE CONDUCTED. THE SAMPLE CONFIGURATIONS WILL SIMULATE STAGES OF END ITEM MANUFACTURE AND ASSEMBLY.

(4492) TITLE - WATER DELUGE SYSTEM APPLICATION IN MUNITIONS PLTS 303

PROBLEM - INFORMATION ON DELUGE REQUIREMENTS FOR EXTINGUISHING FIRES FROM EXPLOSIVES + PROPELLANTS PRIOR TO THE MATERIALS PROCEEDING TO DETONATION IS NOT AVAILABLE TO THE ARMY. THIS INFORMATION CANNOT BE INTRAPOLATED BETWEEN PROPELLANTS AND EXPLOSIVES.

SOLUTION - WATER DELUGE SYSTEMS WILL BE DEVELOPED TO EXTINGUISH FIRES FROM VARIOUS EXPLOSIVES + PROPELLANTS PRIOR TO DETONATIONS. THIS DATA WILL BE INCORPORATED INTO FIRE EXTINGUISHING MANUALS AND APPLIED TO OLD + NEW CONSTRUCTION IN AMMO PLANTS.

(4493) TITLE - DESIGN PARAMETERS FOR LARGE SCALE PROCESS VESSELS 275 300

PROBLEM - INFORMATION IS REQUIRED TO DEVELOP HOPPERS FOR ENERGETIC MATERIAL SO THAT IF FIRE OCCURS DETONATIONS CAN BE PREVENTED.

SOLUTION - PRESSURE RISES FOR DIFFERENT VENT RATIOS WILL BE OBTAINED. FROM THIS A DESIGN WILL BE DEVELOPED AND FULL SCALE TESTS CONDUCTED FROM THE DATA. THE VENT RATIO WILL BE DETERMINED FOR ANY SIZE VESSELS.

\*\*\*\*\*  
\* C A T E G O R Y \*  
\*-----\*  
\*SMALL ARMS \*  
\*\*\*\*\*

COMPONENT -- GENERAL

(S410) TITLE - TRACER BULLET JACKET IMPR MFG PROCESS

210

PROBLEM - TRACER AMMO IS MORE SENSITIVE TO BULLET JACKET DRAW QUALITY THAN STANDARD CARTRIDGE. GILDING METAL CLAD STEEL JACKET DRAW PROCESS REQUIRES IMPROVED TOOL CONTROL, EQUIPMENT AND INCREASED PROCESS SURVEILLANCE.

SOLUTION - EVALUATE DRAW PROCESS TO DETERMINE CRITICAL PROCESS PARAMETERS THAT CONTROL JACKET QUALITY. ENDEAVOR TO ESTABLISH IMPROVED TOOL DESIGN.

(S412) TITLE - AUTOMATIC CARTRIDGE CASE HARDNESS MEASUREMENT

250 400

PROBLEM - MANUAL MEASUREMENTS BY SAMPLING METHODS ARE INADEQUATE AND COSTLY.

SOLUTION - DIRECT EDDY CURRENT TECHNIQUE WOULD PROVIDE CONTINUOUS AND 100% INSPECTION

(4350) TITLE - BULK PACKAGING OF M13 LINKS F/7.62 AMMO

98 113

PROBLEM - MANUAL PACKING 20 LINK IN CARTONS THEN OVERPACKING 372 SMALL IN LARGER CARTONS.

SOLUTION - DETERMINE OPTIMUM METHODS AND USING UNSCRAMBLE CONCEPT.

(4351) TITLE - IMPROVED STORAGE TECHNOLOGY FOR PRODUCTION MACHINE

429 250 335

PROBLEM - NEED TO OVERCOME DEGRADATION OF ELECTRONIC COMPONENTS + MEET RAPID REACTIVATION OF AUTO PDN LINES F/HOB REQUIREMENTS.

SOLUTION - DEVELOP PACKAGING TECHNIQUE AND USE OF DRY NITROGEN FOR SCAMP EQUIPMENT.

(4464) TITLE - COMPUTER/GROUP TECHNOLOGY FOR SMALL CAL AMMO

249 208

PROBLEM - PRESENTLY THERE IS NO METHOD TO OPTIMIZE DESIGN OF TOOLING AND TO SELECT PROPER EQUIPMENT FOR SMALL CALIBER AMMO.

SOLUTION - INVESTIGATE POSSIBLE USE OF COMPUTER FOR OPTIMUM TOOL AND EQUIPMENT DESIGN, AND TO PREDICT PROCESS PARAMETERS AND COSTS.

COMPONENT -- METAL PARTS

(S411) TITLE - PROCESS F/20MM TUBULAR PROJ F/AIR DEFENSE

145 686

PROBLEM - HIGH VOLUME PRODUCTION PROCESS DOES NOT EXIST FOR METAL PARTS, LOAD ASSEMBLE AND PACK.

SOLUTION - DEVELOP PRODUCTION PROCESS.

PRIOR 80 81 82 83 84

COMPONENT -- METAL PARTS

(CONTINUED)

(4168) TITLE - NON-POLLUTING, LOW COST COATING PROCESS FOR SMALL ARMS CASES 150 100

PROBLEM - CURRENT FINISHING PROCESS FOR BUSHMASTER STEEL CASES CONSISTS OF ZINC ELECTROPLATING, CHROME CONVERSION COATING, POLYAMIDE TOPCOATING, AND WASTE TREATMENT TO CONTROL HAZARDOUS CYANIDES AND HEAVY METAL POLLUTANTS

SOLUTION - ESTABLISH THE ELECTROLESS ZINC COATING PROCESS WHICH CONSISTS OF IMMERSING CLEAN CASES IN A WATER DISPERSION OF ZINC FLAKES, CHROMATES AND SOME SOLVENT. THE PARTS ARE THEN SPUN AND BAKED. NO POLLUTANTS ARE GENERATED

(4459) TITLE - WELDED OVERLAY ROTATING BAND MACH F/LC MUN 340 150

PROBLEM - HIGH SPEED WELDING MACHINES FOR ROTATING BANDS DO NOT EXIST FOR 20MM - 40MM PROJECTILES.

SOLUTION - DEVELOP WELDING MACHINE.

(4463) TITLE - MACHINING OF BRASS CARTRIDGE CASES 170

PROBLEM - TOOL MORTALITY TO MACHINE EXTRACTOR GROOVE IS EXCESSIVE AND PRODUCES GREAT DEAL OF SCRAP. ALSO HOLDING COMPONENTS IS A PROBLEM.

SOLUTION - FIND ALTERNATE DESIGNS FOR CUTTING TOOLS. INVESTIGATE NEW WAYS TO HOLD COMPONENTS FIRMLY IN PLACE.

COMPONENT -- 5.56MM - .30 CAL 615

(D017) TITLE - SCAMP EQPT FOR RELOADING SPENT CARTRIDGE CASES

PROBLEM - CURRENTLY THE ARMY DOES NOT RELOAD SPENT CARTRIDGE CASES. CASES ARE SOLD AS SCRAP OR OTHERWISE DISPOSED OF. A SAVINGS CAN BE OBTAINED BY RELOADING THESE SPENT CASES.

SOLUTION - DEVELOP THE NECESSARY SCAMP COMPATIBLE EQUIPMENT WHICH IS REQUIRED TO PROCESS THE CASES BEFORE THEY CAN BE RELOADED. CLEANING, ORIENTING, AND MEASURING OPERATIONS WILL BE REQUIRED.

(S407) TITLE - 7.62MM BULLET MFG BY ROLL FORMING 220

PROBLEM - METHOD TO MANUFACTURE 7.62 UTILIZES SAME PROCESS AS 5.56. IT IS UNCERTAIN WHETHER IT WILL WORK ON 7.62.

SOLUTION - INVESTIGATE OTHER METHODS OF PRODUCING 7.62 BULLET ROLL FORMING APPEARS VERY PROMISING.

(2743) TITLE - IMPROVED TECH FOR SMALL CALIBER AMMUNITION 500

PROBLEM - THE SMALL ARMS MUNITION PRODUCTION BASE MUST KEEP ABREAST OF THE RAPIDLY EMERGING NEW MANUFACTURING TECHNIQUES ON A COST/PRODUCTIVITY BASIS.

SOLUTION - CONTINUALLY MONITOR THE SMALL ARMS DEVELOPMENTS AND APPLICABLE EMERGING MANUFACTURING TECHNOLOGY.

FUNDING (\$000)

PRIOR 80 81 82 83 84  
-----

COMPONENT -- 5.56MM - .30 CAL

(CONTINUED)

(4150) TITLE - NEW MFG PROCESSES FOR SMALL CAL PENETRATORS

437 489 211

PROBLEM - MANUFACTURE OF PENETRATORS INTO BALL BULLETS IS VERY COSTLY.

SOLUTION - INVESTIGATE SKEWED AXIS ROLL FORMING OF PENETRATOR AS WELL AS HYBRID SLUGS MANUFACTURING AND FEEDING METHODS. COLD HEADING WILL ALSO BE EVALUATED.

(4177) TITLE - NEW METH OF SM CAL TRACER CHARGE

850 615 1150

PROBLEM - CURRENT FACILITIES AT LCAAP ARE 1942 VINTAGE CRANK TYPE CHARGING MACHINES AND ARE LABOR INTENSIVE.

SOLUTION - DEVELOP MODERNIZED TRACER CHARGING EQUIPMENT TO MEET REQUIREMENTS OF BULLET SUBMODULES AND TO IMPROVE PRODUCT UNIFORMITY AND INCREASED PERFORMANCE.

(4411) TITLE - SMALL CALIBER AMMUNITION PROCESS IMPROVEMENT PROGRAM

453

PROBLEM - PROJECT 574 6200 IS SCHE 0-ED FOR TERMINATION ON 28 FEB 80. SEVERAL OF THE TASKS INCLUDING- EQUIP, FAILURE PREDICTION, REDESIGN OF LOAD + ASSEMBLE SUBMODULE BULLET + CASE FEEDERS AND EVAL. OF CARTRIDGE CASE CUPS HAVE NOT BEEN COMPLETED.

SOLUTION - PROVIDE THE FUNDING NECESSARY TO COMPLETE THESE TASKS UNDER THIS PROJECT NUMBER.

(4483) TITLE - SMALL CALIBER HYBRID CORE HIGH SPEED FEEDING

298

PROBLEM - NO CAPABILITY EXISTS FOR THE ECONOMICAL MASS PRODUCTION EITHER ON SCAMP OR CONVENTIONAL EQUIPMENT. OF 5.56MM PENETRATOR AMMUNITION SUCH AS THE XM777 BULLET.

SOLUTION - MODIFY THE SCAMP BULLET SUBMODULE TO ACCEPT OFF-LINE ASSEMBLED HYBRID BULLET CORES. THE HYBRID CORE WILL BE FED TO THE BULLET SUBMODULE USING A CENTRIFUGAL FEEDER AND ORIENTER SIMILAR TO THAT USED FOR FEEDING CORES, BULLETS, + LEAD IN OTHER SCAMP EQP

COMPONENT -- 5.56MM - .30CAL

(S409) TITLE - MANUFACTURE OF SMALL CALIBER STEEL CARTRIDGE CASES

300 400

PROBLEM - FROM THE MATERIALS STANDPOINT STEEL OFFERS AN ATTRACTIVE COST ADVANTAGE OVER BRASS FOR SMALL CALIBER (5.56MM-30MM) CARTRIDGE CASE MANUFACTURE.

SOLUTION - THIS STUDY WILL OPTIMIZE A PROCESS COMPATIBLE WITH SCAMP EQUIPMENT FOR THE PRODUCTION OF 5.56/7.62MM STEEL CARTRIDGE CASES.

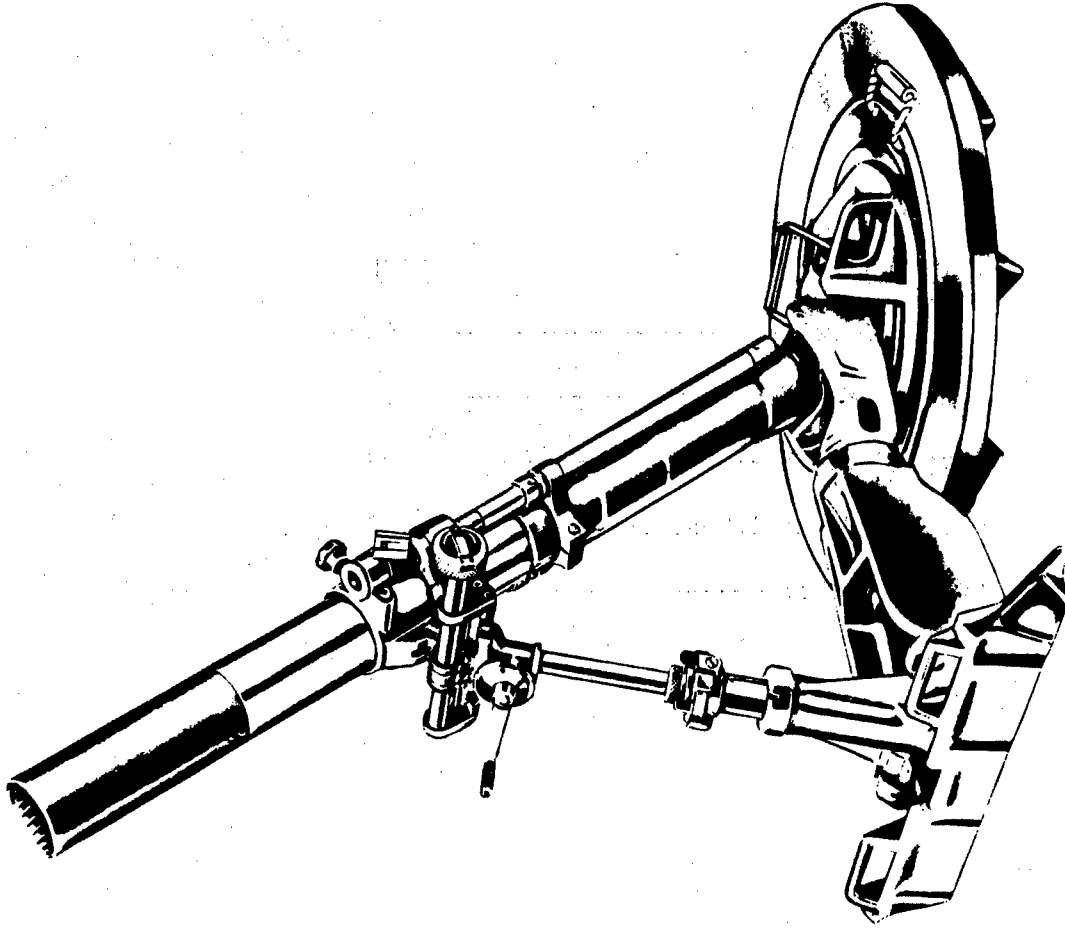

**ARMAMENT R&D COMMAND  
ARMAMENT MATERIEL READINESS COMMAND  
(ARRADCOM, ARRCOM)  
(WEAPONS)**

<u>CATEGORY</u>	<u>PAGE</u>
Fire Control -----	68
General Manufacturing -----	70
Large Caliber -----	78
Quality Control/Testing -----	88
Small Caliber -----	89

## WEAPONS PROGRAM

The US Army Armament Materiel Readiness Command (ARRCOM), headquartered at Rock Island, IL, has responsibility for MMT projects on weapons in full scale production. ARRADCOM is responsible for MMT projects for weapons in development or initial production. Most of the weapons projects are performed through Watervliet Arsenal (WVT) and Rock Island Arsenal (RIA). The main emphasis of the weapons MMT program is the modernization and upgrading of operations through the REARM program. The purpose is to reduce costs and improve product quality by taking advantage of the advances in metalworking technology.

Many of the projects planned for FY80-84 at Watervliet Arsenal are related, in whole or in part, to the handling and fixturing of cannon tubes and their components. Since most items produced at Watervliet are complex and/or require close tolerances, the setup and movement time are important cost drivers. While it is not economically or practically feasible to develop an integrated material handling system for the Arsenal, extensive savings can be realized through improvement of present methods.

A major cost driver at WVT is the machining of items to final shape. Since the alloys used in weapons are expensive and difficult to work, producing components close to final shape will reduce the cost and time required for finishing. Methods being explored include hot isostatic pressing (HIP) (7926), and powder metallurgy (PM) (8102). Projects are also proposed to improve the metal removal process. High speed metal removal is addressed in three projects (8024, 8103, and 8106), and three projects are included to perform multiple operations at one time (8105, 7925, and 8342). Some of the other areas in the Watervliet submission include group technology (7724), computer-aided manufacturing (7928), and finding substitutes for critical materials (7920).

Cost reductions and productivity increases in manufacturing continue to be the prime objectives of MMT at Rock Island Arsenal. Because RIA is a job-shop organization, administration and planning overhead is a significant cost driver. By developing an integrated computer-aided manufacturing/management information system the Arsenal will be able to efficiently control all operations from receipt of an order to delivery of the product. Some of the management areas addressed include production scheduling (8131), process modeling (8130), group technology (7949), performance measurement (8132) and a computer-aided work measurement system (8226). Cost benefits are also expected from improved material handling and in-process control projects which are tied into the overall CAM/MIS effort at RIA. Efforts in this area include robot loading of machines (8227), and automated process control (7707).

Since RIA's task is primarily metalworking, there are several projects included in this area. While all efforts will in themselves reduce costs, coupling with the Arsenal's overall CAM/MIS will further increase the benefits. Some of the areas covered include casting (8231 and 7605), forging (7615), welding (8304), cutting fluids (7948), and electro-chemical grinding (8225).

The minimization of energy consumption and pollution during manufacturing is a national priority and an important part of RIA's MMT submission. Areas being studied include heat recovery (7945), non-polluting manufacturing processes (8017), and optimized heat treatment processes (8244). As anti-pollution requirements become more stringent, it is necessary for manufacturers to improve their environmental posture while maintaining a competitive position or face close down by economic or legal factors. Rock Island Arsenal's MMT submission will correct present environmental difficulties and help prevent future ones so that the Arsenal's vital defense role will not be jeopardized.

Improved metalworking methods and increased use of computer-aided manufacturing are major production trends and the results of the projects in this submission are expected to hold significant interest for other producers, both Government and non-government. These projects will also be of importance in the modernization and upgrading of the facilities of weapons contractors, many of which are seriously outdated.

ARRCOM  
 COMMAND FUNDING SUMMARY  
 (THOUSANDS)

CATEGORY	FY80	FY81	FY82	FY83	FY84
FIRE CONTROL	607	1230	1931	679	1589
GENERAL MANUFACTURING	1082	1650	2279	3793	2559
LARGE CALIBER	3683	2667	4872	2749	2352
QUALITY CONTROL/TESTING	126	80	187	460	460
SMALL CALIBER	450	653	965	1373	1660
TOTAL	5948	6280	10234	9054	8620

\*\*\*\*\*  
 \* C A T E G O R Y \*  
 \*-----\*  
 \*FIRE CONTROL \*  
 \*\*\*\*\*

HMT FIVE YEAR PLAN  
 RCS DRCMT 126

FUNDING (\$000)

PRIOR 80 81 82 83 84  
 -----

COMPONENT -- ASSEMBLIES

(3901) TITLE - MANUFACTURE FLUIDIC AMPLIFIERS BY COLD FORMING 290 59

PROBLEM - PRESENT METHODS OF MANUFACTURING FLUIDIC AMPLIFIERS ARE COSTLY AS THEY REQUIRE 100 PER CT INSPECTION BECAUSE OF UNSATISFACTORY REPEATABILITY IN DIMENSIONS AND FINISHES.

SOLUTION - ADAPT THE COLD FORMING MANUFACTURING PROCESS TO THE PRODUCTION OF ALUMINUM FLUIDIC AMPLIFIERS.

(8010) TITLE - PRODUCTION OF ACOUSTIC MICROWAVE FILTERS 233 150

PROBLEM - ACOUSTIC MICROWAVE FILTERS CAN BE PRODUCED UNDER LABORATORY CONDITIONS AT THE RATE OF 1 TO 2 PER MONTH. A PRODUCTION METHOD CAPABLE OF PRODUCING APPROXIMATELY 30 PER DAY IS NEEDED.

SOLUTION - ESTABLISH A PILOT LINE CAPABLE OF MANUFACTURING THE FILTERS AT REQUIRED RATE. A TWO YEAR EFFORT IS PLANNED.

COMPONENT -- GENERAL

(7966) TITLE - PRODUCTION ENGINEERING FOR TRITIUM RADIO-LUMINOUS LAMPS 125 249

PROBLEM - CURRENT METHODS OF CONTROLLING MOISTURE CONTENT, SEALING AND ALUMINIZING TRITIUM LAMPS ARE BELIEVED RESPONSIBLE FOR THE PRESENT LACK OF DEPENDABILITY.

SOLUTION - DETERMINE THE PRODUCTION CONDITION THAT WILL RESULT IN OPTIMUM HALF-BRIGHT LIFE AND MODIFY CURRENT PRODUCTION METHODS ACCORDINGLY.

(8263) TITLE - PROD. IN-PROCESS INSPECT EQUIP FOR LASER RANGE FINDER CHARAC 350

PROBLEM - CURRENT PRODUCTION/IN-PROCESS INSP. TECHNIQUES ARE REJECTING GOOD LASER RANGE FINDERS. THE REJECTION OF GOOD LRF IS ATTRIBUTED TO INACCURACIES OF RADIOMETERS AND INCANDESCENT LIGHT SOURCES USED TO MEASURE THE LASER POWER OUTPUT AND SENSITIVITY.

SOLUTION - ADVANCES IN ELECTRO-OPTICAL TECHNOLOGY, DIGITAL RADIOMETERS AND CALIBRATED SOLID STATE LIGHT SOURCES WILL BE USED TO CORRECT CURRENT INSP. INACCURACIES.

(8363) TITLE - DISTRIBUTED NETWORK FOR FIRE CONTROL-MANUFACTURING 244 339

COMPONENT -- OPTICS

	272	126		185	266	165
(7807) TITLE - PROGRAMMED OPTICAL SURFACING EQUIP AND METHODOLOGY-CAM						
PROBLEM - CURRENT TECHNIQUES FOR PITCH BUTTONING AND BLOCKING PRECISION LENSES USE OLDER CONVENTIONAL EQUIP. ACCURACY DEPENDS ON THE SKILL AND EXPERIENCE OF WELL TRAINED MASTER OPTICIANS WHO ARE BECOMING SCARCE.						
SOLUTION - ADOPT COMPUTER TECHNIQUES AND INSTRUMENTATION WITH CONTROLS TO PITCH BUTTONING AND BLOCKING OPERATIONS. THE END PRODUCT WILL BE AN INTEGRATED SURFACING SYSTEM IMPLEMENTED IN THE FIRE CONTROL FABRICATION FACILITY AT ARRADCOM.						
(8042) TITLE - ADAPTATION OF INTEGRATED OPTICS TO FIRE CONTROL						
(8054) TITLE - IMPROVE MFG TECH AND QUAL OF OPTICAL SCRATCH AND DIG STAND						
PROBLEM - PRESENT OPTICAL SCRATCH AND DIG STANDARDS ARE DIFFICULT AND EXPENSIVE TO MANUFACTURE,CALIBRATE,AND MAINTAIN						
SOLUTION - ESTABLISH STANDARD MFG METHODS AND EQUIPMENT FOR EFFICIENTLY PRODUCING IMPROVED OPTICAL SCRATCH AND DIG STANDARDS.VALIDATE THE IMPROVED MFG TECHNIQUES.						
(8080) TITLE - HIGH SPEED FABRICATION OF ASPHERIC OPTICAL SURFACES						
PROBLEM - THE BULD OF COST OF OPTICS FOR FIRE CONTROL SYSTEMS LIES IN THE FIGURING AND POLISHING STAGE.						
SOLUTION - USE THE TUBULAR TOOL GRINDING PROCESS TO PRODUCE ASPHERIC SURFACES DIRECTLY DURING THE GRINDING PROCESS						
(8108) TITLE - THERMOGRAPHIC EVALUATION OF OPTIC BANDS						
PROBLEM - THE BOND BETWEEN OPTICAL ELEMENTS AND THEIR STRUCTURAL SUPPORTS MUST BE FREE OF VOIDS, OF UNIFORM THICKNESS AND OF SUFFICIENT STRENGTH TO HOLD FAST AND MAINTAIN ALIGNMENT UNDER SEVERE SHOCK.						
SOLUTION - INTRODUCE THERMOGRAPHIC PROCEDURES TO THE INSPECTION OF OPTICAL BONDS.						
(8165) TITLE - STANDARDS FOR DIAMOND TURNED OPTICAL PARTS						
PROBLEM - EXISTING SURFACE FINISH STANDARDS AND TESTING EQUIPMENT AND TECHNIQUES DO NOT COVER THE RANGE OF DIAMOND TURNED OPTICAL SURFACES FOR A PRODUCTION ENVIRONMENT (1/2 TO 1 MICROINCH).						
SOLUTION - CORRELATE LASER SCATTEROMETRY AND INTERFERENCE CONTRAST MICROSCOPY WITH FUNCTIONAL OPTICAL TESTING TO OPTIMIZE THE SPECIFICATION OF THE SURFACE WITH A MEASUREMENT TECHNIQUE FOR A PRODUCTION ENVIRONMENT.						

COMPONENT -- OPTICS

(CONTINUED)

(8209) TITLE - PILOT PRODUCTION OF GRADIENT INDEX OPTICS

213 284

PROBLEM - GRADIENT OPTICS, WHERE IN THE INDEX OF THE GLASS IS SEQUENTIALLY VARIED TO OBTAIN DESIGNED OPTICAL CHARACTERISTICS IS FAR MORE DESIRABLE THAN CURRENT USED, I.E., FORMING A CURVE ON THE GLASS SURFACE.

SOLUTION - ESTABLISH, SUBSEQUENT TO THE INTRODUCTION AND DEVELOPMENT OF GRADIENT OPTICS TO MILITARY USE, A PILOT PRODUCTION FACILITY TO MANUFACTURE GRADIENT OPTICS AT A REQUIRED RATE.

(8211) TITLE - NET SHAPE OPTICAL PROCESSING

150

PROBLEM - CONSIDERABLE TIME AND EFFORT IS REQUIRED TO PROCESS AN OPTIC FROM A RAW PRESSING TO ITS FINAL SHAPE.

SOLUTION - IMPROVE OPTICAL PRESSING TECHNIQUE TO ACHIEVE NEAR NET SHAPES IN THE INPUT BLANK.

(8261) TITLE - DEBONDING OF EPOXY RESIN ADHESIVE SYSTEM

130

PROBLEM - A RELIABLE AND EFFICIENT PROCEDURE FOR PRODUCTION AND DEPOT MAINTENANCE DEBONDING OF GLASS TO METAL MIL-A-48611 JUNCTIONS DOES NOT EXIST.

SOLUTION - CONVERT DEMONSTRATED LABORATORY DEBONDING TECHNIQUES TO PRODUCTION/DEPOT REPAIR PROCEDURE THAT WILL BE INCLUDED IN MIL-A-48611. THIS PROCEDURE WILL ALLOW FOR THE RECOVERY OF EXPENSIVE OPTICAL ELEMENTS, AND THEIR REUSE.

(8262) TITLE - PRODUCTION METHODS FOR OPTICAL WAVE GUIDES

473

PROBLEM - MANUFACTURE OF INTEGRATED WAVEGUIDES IS COMPLICATED AND TIME CONSUMING INVOLVING PROCESSES RELATED TO METHODS USED TO MAKE SEMICONDUCTOR INTEGRATED CIRCUITS.

SOLUTION - USE ION IMPLANTATION TO ALTER OPTICAL PROPERTIES OF GALLIUM ARSENIDE AND PHOSPHIDE SUBSTRATES TO DIRECTLY FORM OPTICAL WAVEGUIDES IN A ONE-STEP PROCESS.

(8365) TITLE - RADIAL GRADIENT INDEX OPTICS

270

(8467) TITLE - DIAMOND POINT TURNING OF GLASS OPTICS

400

\*\*\*\*\*  
\* C A T E G O R Y \*  
\*-----\*  
\*GENERAL MANUFACTURING \*  
\*\*\*\*\*

COMPONENT -- EQUIPMENT

(7615) TITLE - AUTOMATED FORGING OF WEAPON COMPONENTS (CAM RELATED) 541

PROBLEM - PRESENT FORGING METHODS ARE COMPARATIVELY SLOW AND COSTLY DUE TO CONVENTIONAL EQUIPMENT SPEED LIMITATIONS AND DEPENDENCY ON THE SKILL AND SPEED LEVELS OF THE OPERATOR. WORKING CONDITIONS AROUND DROP HAMMERS ARE HOT, DIRTY AND NOISY.

SOLUTION - ESTABLISH A HIGH SPEED AUTOMATED FORGING CENTER INCLUDING A PROGRAMMABLE FORGING HAMMER, ELECTRIC BILLET-HEATING SYSTEM, PROGRAMMABLE ROBOT MATERIAL HANDLING DEVICE, RELATED CONVEYORS AND OPERATION PARAMETERS.

(8154) TITLE - COMPUTER INTEGRATION MFG (CIM), DNC 337 250

PROBLEM - NUMERICAL CONTROL MACHINE TOOLS OFFER MANY ADVANTAGES OVER CONVENTIONAL MACHINE TOOLS BUT HAVE CERTAIN DISADVANTAGES. ONE PROBLEM AREA IS GETTING MACHINE INSTRUCTIONS TO THE MACHINE TOOL AND COLLECTING MANAGEMENT INFORMATION.

SOLUTION - INTERFACE IN-HOUSE COMPUTER FACILITIES WITH CURRENT AND FUTURE NC MACHINE TOOLS TO FORM AN ADVANCED COMPUTER INTEGRATED MFG SYSTEM. UTILIZE DNC TECHNOLOGY.

(8227) TITLE - ROBOT LOADING OF NC MACHINES 220

PROBLEM - ALTHOUGH MODERN NUMERICALLY CONTROLLED MACHINES CAN MACHINE MANY PARTS WITH VIRTUALLY NO OPERATOR ATTENTION, OPERATORS ARE STILL REQUIRED TO LOAD AND UNLOAD THE MACHINES.

SOLUTION - DESIGN FIXTURES AND BANKS OF MACHINES THAT CAN BE LOADED AND UNLOADED BY A PROGRAMMABLE ROBOT FOR JOB SHOP OPERATION DESIGN THE SYSTEM SO ONE ROBOT CAN LOAD SEVERAL MACHINES WHICH ARE MACHINING DIFFERENT PARTS.

(8304) TITLE - APPLICATION OF NC WELDING (CAM) 186

PROBLEM - ALTHOUGH RIA IS A JOB SHOP, MANY MANUFACTURED ITEMS SUCH AS THE M140 GUN MOUNT, M45 RECOIL MECHANISMS, ETC., HAVE PRODUCTION LIFE SPANS OF MANY YEARS. FOR THOSE ITEMS, NC WELDING WILL PROVE MORE ECONOMICAL AND PROVIDE BETTER QUALITY.

SOLUTION - APPLY NC WELDING TO LONG RUN PRODUCTION PARTS. ON APPLICABLE ITEMS, NC WELDING WILL PROVIDE BETTER REPEATABILITY, EASIER FINAL MACHINING OF THE WELDMENT, REDUCED WELDING TIMES, AND REDUCE THE AMOUNT OF COSTLY WELDING CERTIFICATION REQUIRED.

COMPONENT -- GENERAL

(8471) TITLE - SQUEEZE CASTING OF SMALL CAL WEAPONS 205

COMPONENT -- INFORMATION SYSTEMS

(7963) TITLE - GROUP TECH + CELLULAR MFG FOR FIRE COMPONENTS + ASSEMBLIES 188 303

PROBLEM - FIRE CONTROL MANUFACTURING HAS RESULTED IN THE PROLIFERATION OF MANUFACTURING INFORMATION, LONG SET-UP TIMES OR MULTIPLE RESETTING OF MACHINES, UNDER-UTILIZATION OF MACHINES, LONG AND UNCERTAIN THROUGHPUT TIMES, AND HIGH WORK-IN PROGRESS.

SOLUTION - THROUGH GROUP TECHNOLOGY PART FAMILIES, MACHINE GROUPS, TOOL GROUPS AND WORK GROUPS WILL BE ESTABLISHED TO REALIZE THE FOLLOWING - REDUCED PLANNING EFFORT, SET-UP TIME, WORK-IN PROGRESS, LEVEL OF SCRAP AND MORE EFFECTIVE MACHINE OPERATIONS.

(8130) TITLE - LOWEST COST CHARGING SYSTEM FOR FOUNDRY (CAM) 124

PROBLEM - PRESENT METHODS OF DETERMINING THE CHARGE FOR PARTICULAR ALLOYS DO NOT ALLOW FOR THE MOST EFFICIENT USE OF RAW MATERIAL.

SOLUTION - DESIGN AND INSTALL A COMPUTERIZED LINEAR PROGRAMMING MODEL THAT WILL SELECT RAW MATERIALS, INCLUDING SCRAP, TO PROVIDE THE LOWEST COST CHARGE FOR THE DESIRED ALLOY.

(8131) TITLE - COMPUTER AIDED PBS PLANNING (CAM) 173

PROBLEM - MANUAL METHODS OF SELECTING EQUIPMENT REPLACEMENT CANDIDATE MACHINES CANNOT TAKE ADVANTAGE OF THE COMPUTERIZED PRODUCTION DATA COLLECTED ON EACH MACHINE.

SOLUTION - DESIGN A SET OF COMPUTER PROGRAMS THAT CAN EVALUATE PRODUCTION DATA SUCH AS PROJECTED WORKLOAD, MAINTENANCE COSTS, DOWNTIME, EFFICIENCY AGAINST STANDARD, ETC. AND IDENTIFY CANDIDATE MACHINES FOR REPLACEMENT.

(8132) TITLE - PERFORMANCE MEASUREMENT PARAMETERS FOR GOGO MFG. 274

PROBLEM - MEASURING THE PERFORMANCE OF A GOVERNMENT MANUFACTURING OPERATION IS DIFFICULT. GOGO OPERATIONS, ALTHOUGH PARTIALLY COMPETITIVE, ARE NOT IN A FULLY COMPETITIVE MARKETPLACE. ACCOUNTING DATA BE ITSELF IS NOT SUFFICIENT TO MEASURE PERFORMANCE.

SOLUTION - DEVELOP A SERIES OF MEASUREMENTS THAT COMBINE ACCOUNTING DATA AND PRODUCTION DATA TO ADEQUATELY ASSESS PERFORMANCE. INCLUDE DATA ON TECHNOLOGICAL IMPROVEMENTS, INFLATION, PRODUCT COST, ETC. MEASUREMENTS WILL BE USEFUL IN LONG RANGE PLANNING.

(8218) TITLE - INTEGRATED COMPUTER AIDED MANUFACTURING (CAM) 350 350

PROBLEM - ROCK ISLAND ARSENAL IS PERFORMING CAM RELATED PROJECTS IN MANY AREAS, E.G., MACHINE CONTROL, PRODUCTION CONTROL, PROCESS ENGINEERING, ETC. THE TASK OF BRIDGING THE GAP BETWEEN THE AREAS HAS NOT YET BEEN ADDRESSED.

SOLUTION - INTEGRATE THE VARIOUS AREAS OF COMPUTER AIDED MANUFACTURING. FOR INSTANCE, LINK SHOP PERFORMANCE ON MANUFACTURING OPERATIONS BACK TO THE PROCESS PLANNING OPERATION.

COMPONENT -- INFORMATION SYSTEMS (CONTINUED)

(8226) TITLE - COMPUTER AIDED WORK MEASUREMENT SYSTEM (CAM) 205

PROBLEM - TIME STUDIES AND USE OF STANDARD DATA PRESENTLY REQUIRE TIME CONSUMING MANUAL CALCULATIONS TO DEVELOP PRODUCTION STANDARDS.

SOLUTION - DEVELOP A COMPUTERIZED WORK MEASUREMENT SYSTEM THAT WILL VIRTUALLY ELIMINATE MANUAL CALCULATIONS IN THE DEVELOPMENT OF PRODUCTION STANDARDS. ROUTINES WILL INCLUDE PROGRAMS TO DEVELOP FINISHED STANDARDS FROM RAW TIME STUDIES OR STANDARD DATA.

(8247) TITLE - WELDING HANDBOOK FOR WEAPONS SYSTEMS 180 165

PROBLEM - SPECIFIC PROCEDURES FOR WELDING WEAPON SYSTEMS COMPONENTS ARE DIFFICULT TO FIND OR DECIPHER. THIS MAY RESULT IN THE USE OF IMPROPER OR ECONOMICAL WELDING METHODS.

SOLUTION - PREPARE A HANDBOOK SPECIFICALLY FOR WELDING WEAPON SYSTEMS COMPONENTS AND MAKE THE DATA BASE FOR THE HANDBOOK AVAILABLE FOR COMPUTER SEARCH.

COMPONENT -- MISCELLANEOUS

(7945) TITLE - HEAT RECOVERY FROM MANUFACTURING PROCESSES 140

PROBLEM - LARGE AMOUNTS OF ENERGY ARE WASTED IN MANUFACTURING PROCESSES, E.G., HEAT TREATING, FORGING, SURFACE TREATMENT, AND CASTING.

SOLUTION - ANALYZE ENERGY CONSUMPTION RELATED TO THESE MANUFACTURING PROCESSES TO DETERMINE AREAS WHERE HEAT CAN BE ECONOMICALLY RECOVERED. DESIGN, INSTALL, AND PROVE OUT HEAT RECOVERY DEVICES WHERE ECONOMICAL.

(8017) TITLE - POLLUTION ABATEMENT PROGRAM 143 171

PROBLEM - MORE STRINGENT ENVIRONMENTAL REQUIREMENTS ARE BEING ESTABLISHED FOR AIR AND WASTE WATER DISCHARGE.

SOLUTION - NEW NON-POLLUTING MANUFACTURING PROCESSES WILL BE EVALUATED AS SUBSTITUTES FOR PRESENT AIR AND WATER POLLUTING PROCESSES IN THE AREAS OF PLATING, MACHINING AND RUBBER COMPOUNDING.

(8030) TITLE - MANUFACTURING GUIDE FOR ELASTOMERIC SEALS 121 162 121

PROBLEM - CONSTANT PROBLEMS IN THE PROCUREMENT OF SATISFACTORY SEALS FOR WEAPONS SYSTEMS, I.E., M140, M127, ETC., ARE EXPERIENCED WITH RESULTANT SOLE SOURCE PURCHASES.

SOLUTION - ELIMINATE SOLE SOURCE PROCUREMENT BY DOCUMENTING PROCESSING TECHNIQUES AND FORMULA VARIATIONS FOR A VARIETY OF MILITARY SEALS FOR PUBLICATION IN A GUIDE FOR USE BY INDUSTRY.

COMPONENT -- MISCELLANEOUS

(CONTINUED)

(8160) TITLE - INITIAL PRODUCTION HANDBOOK

414 328 337

PROBLEM - A HIGH PERCENTAGE OF CRITICAL FIRE CONTROL EQUIPMENT FAILS FIRST ARTICLE TESTS. THE FAILURES ARE TRACEABLE TO THE USE OF INADEQUATE OR OUTDATED PRODUCTION AND TEST PROCEDURES.

SOLUTION - IDENTIFY AND ISOLATE FIRE CONTROL PRODUCTION PROBLEMS. INVESTIGATE AND TEST NEW TECHNIQUES TO ELIMINATE INADEQUATE MANUFACTURING PROCEDURES. DOCUMENT GENERIC PRODUCTION PROBLEMS RELATED TO FIRE CONTROL ITEMS.

(8252) TITLE - INDUCTION HEATING OF VARYING DIAMETER PREFORMS

237

PROBLEM - INDUCTION HEATING OF RECYCLED GUN TUBES AND TAPERED PREFORMS REQUIRES VARYING POWER INPUTS TO OBTAIN A UNIFORM TEMPERATURE. THE PRESENT POWER CONTROL DOES NOT PROVIDE THE AUTOMATIC AND PRECISE CONTROL OF POWER NEEDED.

SOLUTION - DESIGN A DEVICE THAT AUTOMATICALLY ADJUSTS POWER TO THE COILS BASED ON THE PREFORM DIAMETER AT THE SECTION ENTERING THE COIL.

(8464) TITLE - PLASTIC COMPONENTS/INSTRUMENTS

300

(8466) TITLE - INTEGRATED MILLIMETER WAVE COMPONENTS

250

COMPONENT -- PROCESSES

(7605) TITLE - CHEMICALLY BONDED SAND FOR CLOSE TOLERANCE CASTINGS

127 174

PROBLEM - PRESENT METHODS OF MOLDING AND CORE MAKING ARE COSTLY, ENERGY WASTEFUL, AND UNSUITABLE FOR HOLDING CLOSE TOLERANCES.

SOLUTION - INSTALL CHEMICALLY BONDED SAND CORE MAKING AND MOLDING SYSTEM AT ROCK ISLAND ARSENAL WHICH WILL REDUCE LABOR COST, ELIMINATE BAKING CORES, AND CREATE MORE RIGID HOLDS.

(7707) TITLE - AUTOMATED PROCESS CONTROL FOR MACHINING (CAM)

105 133

PROBLEM - MACHINING OPERATIONS ARE SELECTED, PARAMETERS ARE SET, AND STANDARDS ARE ESTABLISHED EMPIRICALLY WITH LITTLE OR NO ENGINEERING ANALYSES, CONTROL OR FEEDBACK.

SOLUTION - APPLY COMPUTERIZED CONTROLS FOR OVERALL SELECTION OF PROCESSES, OPERATIONS, PARAMETERS, FEEDBACK AND OPTIMATION, WITH AUTOMATED ESTIMATING AND DETERMINATION OF REAL TIME AND COSTS.

(7940) TITLE - SYNERGISTIC PLATINGS WITH INFUSED LUBRICANTS

121 172

PROBLEM - LOW FRICTION, WEAR RESISTANT SURFACES ARE NEEDED FOR COMPONENTS IN SLIDING CONTACT.

SOLUTION - USE OF TWO-SYSTEM COATINGS INCORPORATING SOLID LUBRICANT INTERLOCKED WITH METAL PLATING.

PRIOR 80 81 82 83 84

COMPONENT -- PROCESSES

(CONTINUED)

(7948)	TITLE - ESTABLISH CUTTING FLUID CONTROL SYSTEM	150	158	164	
	PROBLEM - THE LACK OF A CONTROLLED PROGRAM FOR THE USE OF CUTTING FLUIDS RESULTS IN HIGH MACHINING COSTS AND STOCKING OF MANY FLUIDS.				
	SOLUTION - ESTABLISH A PROGRAM TO CONTROL SHOP FLOOR TESTING AND DEFINE METHODS TO CONTROL USE OF CUTTING FLUIDS DURING MANUFACTURING OPERATIONS.				
(7949)	TITLE - APPLICATION OF GROUP TECHNOLOGY MANUFACTURING (CAM)	127	155		
	PROBLEM - PRESENT PLANNING, SCHEDULING, AND MANUFACTURE OF WEAPON ASSEMBLIES AND COMPONENTS ARE BY SEPARATE LOTS AND PARTS WHICH REQUIRE MULTIPLE, MACHINING OPERATIONS, SET-UPS AND CHANGES OF TOOLING, AND CAUSE LOSS OF TIME AND MONEY.				
	SOLUTION - APPLY GROUP TECHNOLOGY TO CLASSIFY, CODE AND MANUFACTURE WEAPON ASSEMBLIES AND COMPONENTS AS FAMILIES-OF-PARTS. MATCH PARTS BY CONTOUR AND SIZE FOR SIMULTANEOUS MACHINING- AND, SUB-GROUP FOR MORE EFFICIENT MACHINING AND ASSEMBLY.				
(8004)	TITLE - CO-DEPOSITION OF SOLID LUBRICANTS DURING ANODIZING	120	121		
	PROBLEM - LOW FRICTION, HARDCOST SURFACES ARE NEEDED FOR ALUMINUM COMPONENTS.				
	SOLUTION - APPLY ELECTROLYTIC ANODIC COATINGS WHILE SIMULTANEOUSLY DEPOSITING SOLID LUBRICANT PARTICLES WITHIN THE COATING.				
(8006)	TITLE - ALLOY PLATING TO REDUCE CONSUMPTION OF CRITICAL MATERIAL				166
	PROBLEM - SEVERAL COATING MATERIALS SUCH AS CHROMIUM ARE IN SHORT SUPPLY.				
	SOLUTION - REPLACE OR REDUCE THE AMOUNT OF CRITICAL ELEMENTS IN THE COATING BY ALLOY PLATING.				
(8008)	TITLE - "MANUAL" ADAPTIVE CONTROL (CAM)				120
	PROBLEM - APPLICATION AND ADJUSTMENT OF MACHINING RATES AND OTHER PARAMETERS IS UNCERTAIN, SLOW AND COSTLY.				
	SOLUTION - APPLY MANUAL-COMPUTER PROGRAMS ON SHOP FLOOR TO OPTIMIZE AND CONTROL MACHINING OPERATIONS.				
(8113)	TITLE - ESTABLISHMENT OF ION PLATING PROCESS FOR ARMAMENT PARTS	150	140		
	PROBLEM - DOD IS REPLACING TOXIC CADMIUM WHEREVER POSSIBLE. CURRENTLY, CADMIUM PLATING IS SPECIFIED FOR APPROXIMATELY 3000 ARMAMENT COMPONENTS. EQUALLY IMPORTANT IS THE ELIMINATION OF THE HYDROGEN EMBRITTLEMENT OF STEEL CAUSED BY ALL ELECTROPLATING PROCESSES.				
	SOLUTION - ION PLATING ALUMINUM COATINGS TO STEEL ARMAMENT SUBSTRATES WILL PROVIDE CORROSION RESISTANCE SUPERIOR TO THAT OF ZINC OR CADMIUM PLATING. ION PLATING AND ELECTROPLATING COSTS ARE SIMILAR. PROCESS NEEDS TO BE ESTABLISHED FOR ARMAMENT ITEMS.				

COMPONENT -- PROCESSES

(CONTINUED)

(8120) TITLE - ADAPTIVE CONTROL TECHNOLOGY (CAM)

225

PROBLEM - INEFFICIENT USE OF NC MACHINE TOOLS DUE TO CONSERVATION PROGRAMMING IS UNECONOMICAL. ALSO THE INABILITY TO MONITOR A MULTIPLICITY OF TOOL FORMS CHARACTERISTIC OF NC MACHINE CAPABILITY, E.G. MANY DRILL SIZES WITH DIFFERENT LOADING, IS A LIMITER.

SOLUTION - EXTEND THE CURRENT ADAPTIVE CONTROL TECHNOLOGY TO CONTROL THE TOOL LOADS IN SMALL MILLS AND DRILLS SO THEY CAN BE PERFORMED IN THE SAME SETUPS. THIS WOULD MAXIMIZE THE USE OF BOTH NC EQUIPMENT AND TOOL SYSTEMS.

(8135) TITLE - SECOND ORDER MFG. METHODS FOR WEAPON COMPONENTS

653 557

PROBLEM - DURING MFG. OF RECOIL CONTROL ORIFICES, ERRORS ARE INTRODUCED WHICH REQUIRE REMARK. CORRECTIVE ACTIONS INVOLVE COSTLY DETAILED INSPECTION AND REANALYSIS WITH COMPUTERIZED DESIGN PROGRAMS TO DEFINE POSSIBLE REMARK ALTERNATIVES.

SOLUTION - AN IMPROVED MANUFACTURING METHOD UTILIZING ADAPTIVE CONTROLS AND AUTOMATED INSPECTION EQUIPMENT WILL BE ESTABLISHED. MACHINE TOOLS WILL BE RETROFITTED.

(8205) TITLE - SURFACE PREPARATION OF METALS BY PRESSURE BLASTING

100

PROBLEM - METAL SURFACES ARE CLEANED FOR FINISHING BY USING CHEMICALS THAT REQUIRE POLLUTION ABATEMENT PROCEDURES.

SOLUTION - DEVELOP PARAMETERS FOR THE USE OF HIGH PRESSURE WATER-INERT MEDIA BLASTING METHODS TO REMOVE DRY FILM LUBRICANTS, AND TO USE FOR DERUSTING, DESCALING AND PAINT STRIPPING OPERATIONS.

(8225) TITLE - ELECTROCHEMICAL GRINDING OF WEAPON COMPONENTS

100

PROBLEM - SIZING AND FINISHING OF LARGE, LONG WEAPON COMPONENTS BY CONVENTIONAL GRINDING IS SLOW AND COSTLY, OFTEN REQUIRING MULTIPLE OPERATIONS, SET UPS, WHEEL CHANGES, AND REPETITIVE MULTIPLE PASSES. FOR EXAMPLE- PLANNING / GRINDING HOWITZER MOUNT RAIL.

SOLUTION - RETROFIT EXISTING, SPECIAL LONG BED, HORIZONTAL, SURFACE GRINDER WITH ELECTROLYTIC SYSTEM TO PROVIDE FAST, SINGLE PASS ROUGHING FINISHING OF LARGE COMPONENTS, ELIMINATE ROUGHING BY PLANNING OR MILLING BEFORE ELECTROLYTIC GRINDING.

(8231) TITLE - IMPROVED CASTING TECHNOLOGY (CAM)

200 250

PROBLEM - EXCESSIVE METAL MUST BE MELTED IN CASTING OPERATIONS. THE YIELD RATIO OF SOME CASTS IS TOO LOW AND THE GATES AND RISERS TOO DIFFICULT TO CUT OFF. MATERIAL PROPERTIES OFTEN VARY WITH CASTING PROCEDURES.

SOLUTION - USING COMPUTERIZED TECHNIQUES AND PRODUCTION CASTING FACILITIES, THE OPTIMUM SHAKE OUT TIMES, RISER SLEEVES AND GATING AND RISERING CONFIGURATIONS WOULD BE DETERMINED. PROPERTIES OF CAST MATERIALS WILL BE EVALUATED FOR DIFFERENT CAST DESIGNS.

COMPONENT -- PROCESSES

(CONTINUED)

(8303) TITLE - CENTRALIZED SYSTEM FOR COOLANTS

100

PROBLEM - CURRENTLY, A NUMBER OF MACHINE TOOLS USE THE SAME COOLANTS. INTERMITTENT USE PRODUCES STAGNATION AND RISE IN BACTERIA. CONTROL OF SYSTEMS IS DIFFICULT ON AN INDIVIDUAL MACHINE BASIS.

SOLUTION - THE IMPLEMENTATION OF A CENTRAL SYSTEM WILL USE LESS COOLANTS BY PROPER CONTROL AND PROVIDE MORE AERATION. CENTRAL SYSTEM WILL REDUCE THE MAINTENANCE, COST AND IMPROVE COOLANT QUALITY.

(8360) TITLE - ESTABLISHMENT OF ZINC ION VAPOR DEPOSITION PROCESS

195

(8401) TITLE - APPLICATION OF HIGH-SPEED MACHINING

275

PROBLEM - HIGH-SPEED MACHINE TOOLS AND ATTACHABLE SPINDLES AND DRIVES ARE NOT BEEN APPLIED BECAUSE PROPER TOOL / WORKPIECE / MACHINE TOOL COMBINATIONS ARE UNKNOWN OR ARE UNCONTROLLED.

SOLUTION - ESTABLISH BALANCED WORKING COMBINATIONS FOR HIGH-SPEED MACHINING AND ESTABLISH ENGINEERING GUIDELINES AND PARAMETERS FOR PRODUCTION USE.

(8402) TITLE - WARM FORGING OF WEAPON COMPONENTS (CAM)

150

PROBLEM - EXCESSIVE ENERGY IS CONSUMED IN CONVENTIONAL FORGING. ALSO DIE LIFE IS SHORTENED BY HIGH FORGING TEMPERATURES AND BY OXIDATION.

SOLUTION - BY USING CAD/CAM TECHNIQUES FOR DIE DESIGN, FORGING WILL BE DONE AT MUCH LOWER TEMPERATURE AND THE FINAL PARTS WILL HAVE BETTER MECHANICAL PROPERTIES

(8403) TITLE - DESIGN CRITERIA FOR HARDENING (CAM)

140

PROBLEM - SELECTION OF THE BEST HARDENING PROCESS. INCOMPLETE HARDENING THROUGHOUT THE COMPONENT AND COMPLICATIONS CAUSED DURING THE HEAT TREATMENT OF WELDMENTS ARE RECURRING PROBLEMS CURRENTLY ADDRESSED BY EMPIRICAL METHODS.

SOLUTION - THE RELATIONSHIPS OF DIFFERENT VARIABLES SUCH AS QUENCH RATES, COMPONENT SIZE, SHAPE, AND COMPOSITION WILL BE ESTABLISHED. A COMPUTER WILL BE PROGRAMMED TO FURNISH THE NECESSARY INFORMATION

COMPONENT -- TOOLING

(8248) TITLE - APPLICATION OF HIGH-RATE CUTTING TOOLS 100

PROBLEM - APPLICATION OF NEW HIGH-RATE CUTTING TOOLS LAG DUE TO LACK OF TESTING, ANALYSES AND ENGINEERED APPLICATIONS. MANUFACTURERS PROVIDE INSUFFICIENT DATA FOR EFFICIENT APPLICATIONS OF CERAMICS, OXIDES, NITRIDES, BORIDES, AND DIAMONDS.

SOLUTION - HIGH-RATE CUTTING TOOLS WILL BE TESTED, ANALYSED, AND APPLIED WITH BOTH NEW AND EXISTING MACHING TOOLS. ENGINEERING GUIDELINES WILL BE ESTABLISHED FOR BOTH PHYSICAL AND ECONOMIC MACHINING PARAMETERS AND LIMITS.

(8400) TITLE - SPECIAL TOOLING FOR FLEXIBLE MANUFACTURING 100

PROBLEM - CONVENTIONAL, N/C, AND FLEXIBLE MANUFACTURING SYSTEMS USE SEPARATE TOOLING WHICH LACKS COMPLETE FLEXIBILITY FOR MULTIPLE-TOOL AND/OR MULTIPLE-SPINDLE CUTTING WITH INTERCHANGEABILITY.

SOLUTION - CLASSIFY TOOLING BY GROUPS, ESTABLISH INTERCHANGEABILITY, APPLY SPECIAL MULTIPLE TOOL AND/OR MULTIPLE-SPINDLE TOOLING IN FLEXIBLE MANUFACTURING OPERATIONS AND SYSTEMS.

\*\*\*\*\*  
\* C A T E G O R Y \*  
\*-----\*  
\*LARGE CALIBER \*  
\*\*\*\*\*

COMPONENT -- BREECH MECHANISMS

(7730) TITLE - MANUFACTURE OF SPLIT RING BREECH SEALS 137 363 106

PROBLEM - SPLIT RINGS REQUIRE PRECISE MFG. PRESENT METHODS ARE OUTDATED AND COSTLY REQUIRING MUCH HAND FINISHING BY HIGHLY SKILLED WORKERS. REJECTION RATE HIGH WITH MUCH REWORK.

SOLUTION - AUTOMATED AND IMPROVED PROCEDURES WILL BE ADOPTED, NEW METHOD OF SLITTING RING REQUIRING LESS STOCK REMOVAL. SPECIAL EQUIPMENT WILL BE DESIGNED AND PURCHASED TO MINIMIZE HAND FINISHING BY HIGH SKILL OPERATORS.

(7926) TITLE - HOT ISOSTATIC PRESSING (HIP) OF LARGE CANNON COMP 216 290

PROBLEM - MANY HOURS ARE REQUIRED TO MACHINE THE BREECH BLOCK FORGING TO THE FINISHED PART. MORE THAN 25% OF FORGING BECOMES CHIPS. WITH HIGH COST OF ALLOY STEEL, THIS BECOMES A VERY COSTLY WASTE OF MATERIAL.

SOLUTION - HOT ISOSTATIC PRESSING (HIP) WILL FORM BREECH BLOCKS TO NEARLY FINAL SHAPE, GREATLY REDUCING MACHINING COSTS.

COMPONENT -- BREECH MECHANISMS (CONTINUED)

(7927) TITLE - GENERATION OF BASE MACHINING SURFACES

86 137

PROBLEM - TO OBTAIN A DISTR OF STOCK ON A ROUGH CAST COMPONENT, IT IS CURRENTLY NECESSARY TO "DRAW" THE FINISHED COMPONENT ON THE MATERIAL USING HT GAGE AND LAYOUT TEMPLATES. THIS IS DONE ON A TABLE FROM WHICH THE PART MOVES TO A MACHINE FOR SIMILAR SET-UP.

SOLUTION - USING PRESENT LAYOUT TECHNIQUES SUCH AS OPTICAL SHADOW LAYOUT TEMPLATES, THE COMPONENT CAN BE POSITIONED DIRECTLY ON THE MACHINE TO ESTABLISH THE FIRST CUT ELIMINATING THE INITIAL LAYOUT OPERATION.

(7928) TITLE - ROBOTIZED BENCHING OPERATIONS (CAM)

113 287

PROBLEM - BENCHING OPERATIONS ON BREECHBLOCKS AND RINGS ARE UNSAFE AND TIME CONSUMING.

SOLUTION - DEVELOP INDUSTRIAL ROBOT TO PERFORM THESE OPERATIONS.

(8062) TITLE - RAPID INTERNAL THREADING

69 69 338

PROBLEM - PRODUCING INTERNAL METRIC THREADS IN BREECH RINGS IS A SERIOUS PRODUCTION PROBLEM BECAUSE OF BOTH THE TECHNIQUES AND TOOLING REQUIRED. CONVENTIONAL THREAD HOBGING PRESENTS A PRODUCTION BOTTLENECK.

SOLUTION - CURRENT TECHNOLOGY AND RECENT TOOLING BREAKTHROUGHS HAVE EXPANDED HIGH SPEED THREADING CONSIDERABLY. AUTOMATED THREADING WILL BE AN EFFICIENT, ECONOMIC REPLACEMENT FOR THE CURRENT MILLING-TYPE THREAD HOBGING PROCESSES.

(8102) TITLE - APPLIC. OF POWDER METALLURGY FORGINGS TO COMP.

131

PROBLEM - FORGINGS AND CASTINGS ARE FABRICATED OVERSIZE AND SUBSEQUENTLY MACHINED DOWN TO FINAL DIMENSIONS. FINAL COMPONENT CONFIGURATION INVOLVES A LARGE AMOUNT OF MANPOWER AND MACHINES TO REMOVE ALLOY STEEL AS CHIPS.

SOLUTION - RECENT ADVANCES HAVE OCCURRED IN POWDER METALLURGY FORGING. THE ADVANCES WILL PRODUCE "NEAR NET SHAPE" COMPONENTS WHICH REDUCES AMOUNT OF MACHINING REQUIRED WHILE KEEPING ADEQUATE MECHANICAL PROPERTIES. UTILIZE NEW TECHNIQUE.

(8105) TITLE - ESTABLISH ROUGH THREAD BLANKS 8 IN. M201 BUSHING

88 307

PROBLEM - A SINGLE POINT TOOL IS NOW USED TO PRODUCE THE ROUGH FORMED BLANK FOR STEP THREADS ON STEP BLOCKS. CURRENT TIME VALUE IS 13.9 HOURS.

SOLUTION - POSSIBLE APPLICATIONS OF MULTIPLE SLOTTING TOOLS AND MILLING OFFER A FAR MORE EFFICIENT METAL REMOVAL PROCESS AIMED AT TIME/COST REDUCTION.

COMPONENT -- BREECH MECHANISMS

(CONTINUED)

(8117) TITLE - SHAPED CASTING OF ESR MATERIAL

202

PROBLEM - COMPONENTS REQUIRE FORGING PLUS EXTENSIVE MACHINING TO ACHIEVE THE FINAL DIMENSIONS. THE FORGING PROCESS HAS IMPARTED SOME PROBLEMS WITH THE MECHANICAL PROPERTIES RECURRING IN THE STEEL.

SOLUTION - A PRODUCTION PROCESS CAPABLE OF PRODUCING A SHAPED CASTING.

(8237) TITLE - MULTIPLE MACHINING OF CARRIER HOUSINGS

101 634

PROBLEM - THE 155MM M185 AND M199 CARRIER HOUSINGS REQUIRE NUMEROUS OPERATIONS FOR THE PRODUCTION OF COMPLEX INSIDE AND OUTSIDE DIAMETERS. STANDARD EQUIPMENT CANNOT PRODUCE THESE FEATURES EFFICIENTLY.

SOLUTION - A SPECIAL EQUIPMENT DESIGN WILL BE APPLIED TO ALLOW MACHINING AS MANY SURFACES AS POSSIBLE IN ONE SETUP.

(8238) TITLE - IMPROVED BORING TOOLS FOR BREECH RING LUGS

200

PROBLEM - PRESENT METHODS OF PRODUCING THE VARIOUS HOLES ON BREECH RINGS ARE TREPANNING, TWIST DRILLING, GUN DRILLING, AND FINISH BORING. PRODUCTION OF THESE HOLES IS A TIME CONSUMING AND COSTLY OPERATION.

SOLUTION - THE JOINT PROCESS OF EJECTOR DRILLING AND INDEXABLE CARBIDE INSERT HOLE DRILLING PROMISES TO REDUCE THE SEQUENCE STEPS NOW REQUIRED AND TO PROVIDE A FAR MORE COST EFFECTIVE MEANS OF PRODUCING AN ACCEPTABLE HOLE.

(8339) TITLE - APPLIC OF NON-TRADITIONAL SURF. HARDENING METHODS

206 267

PROBLEM - PRESENT METHODS OF SURFACE HARDENING WEAPON COMPONENTS ARE COSTLY, TIME CONSUMING, AND MAY IMPART UNDESIRABLE RESIDUAL STRESSES.

SOLUTION - TO TRANSFORM THE SURFACE LAYER OF THE STEEL TO ALLOW MATERIAL TO BE UNIFORMLY GUEINCHED. THE ADVANTAGES ARE LESS ENERGY USAGE, POLLUTION FREE, ALLOW HIGHER PRODUCTION RATES, AND MINIMAL POST-PROCESSING SUCH AS CLEANING AND STRAIGHTENING.

COMPONENT --- GENERAL

(7724) TITLE - GROUP TECHNOLOGY OF WEAPON SYSTEMS

224

PROBLEM - THERE IS A NEED TO REDUCE AND CONTROL THE PROLIFERATION OF PARTS AND DESIGNS FOR ITEMS MANUFACTURED AT WATERVLIET ARSENAL.

SOLUTION - THE ARMY HAS PURCHASED A GROUP CLASSIFICATION AND CODING SOFTWARE PACKAGE. ONCE THIS SYSTEM IS IMPLEMENTED, IT SHOULD BE POSSIBLE TO REDUCE THE NUMBER OF DIFFERENT PARTS THRU STANDARDIZATION.

COMPONENT -- GENERAL

(CONTINUED)

(8059) TITLE - SALVAGE OF CANNON COMPONENTS BY ELECTRODEPOSITION 152

PROBLEM - COMPONENTS AND GUN TUBES HAVE BEEN REJECTED AND CONDENSED DUE TO EXCESS STOCK REMOVAL OR MISHMACHINING.

SOLUTION - DEVELOP A PROCESS TO DEPOSITE ADDITIONAL METAL TO COMPENSATE FOR EXCESS STOCK REMOVAL.

(8249) TITLE - SHORT-CYCLE HEAT TREATING OF WEAPON COMPONENTS 100 125

PROBLEM - HEAT TREATING SOAK TIMES ARE DETERMINED WITHOUT CONSIDERATION OF THE RELATIONSHIPS BETWEEN COMPOSITION, CONFIGURATION, THICKNESS, AND DETRIMENTAL EFFECTS OF AUSTENITIC GRAIN GROWTH. CONSEQUENTLY, CONSIDERABLE ENERGY IS WASTED.

SOLUTION - SUITABLE SYSTEMATIC PRODUCTION METHODS WILL BE USED TO DETERMINE THE PROPERTIES OBTAINED AT MINIMAL PROCESSING TIMES TO REDUCE ENERGY CONSUMPTION AND INCREASE PRODUCTION EFFICIENCY.

COMPONENT -- GUN MOUNTS

(8035) TITLE - COATING TUBE SUPPORT SLEEVES WITH BEARING MATERIALS 180 200

PROBLEM - METALLIZED COATINGS ON SUPPORT SLEEVES FOR GUN MOUNTS ARE BRITTLE AND LACK BOND STRENGTH.

SOLUTION - USE INDUCTION/ARC-INERT GAS METHODS TO COAT SLEEVES WITH BEARING MATERIALS.

(8250) TITLE - IMPROVED FABRICATION OF RECOIL WEAR SURFACES 100 125

PROBLEM - PRESENTLY GRINDING AND HONING OPERATIONS ON WEAK SURFACES RESULT IN PARTICLE INCLUSIONS WHICH COME IN CONTACT WITH HYDRAULIC AND PRODUCE HIGH WEAR RATES.

SOLUTION - USING ADVANCED METHODS REMOVE FOREIGN PARTICLES PRIOR TO THE FINAL GRINDING OR HONING OPERATIONS OR, IF MORE EFFECTIVE, AFTER FINAL GRINDING OR HONING.

(8251) TITLE - IMPROVED MELTING AND POURING TECHNOLOGY 190 164 190

PROBLEM - THERE IS A HIGH REJECTION RATE FOR CASTING POURED AT RIA BECAUSE MODERN TECHNIQUES ARE NOT USED TO MEASURE AND CONTROL PROCESS PARAMETERS AND POROSITY.

SOLUTION - PROCEDURES TO MINIMIZE DISSOLVED GAS AND TO MORE ACCURATELY MEASURE GAS CONCENTRATIONS WILL BE ESTABLISHED. METHODS OF MEASURING TEMPERATURES AND COMPOSITIONS OF ATMOSPHERES IN FURNACES AT RIA WILL BE ESTABLISHED.

COMPONENT -- RECOIL MECHANISMS

(8228) TITLE - BALL SIZING OF RECOIL CYLINDERS

267

PROBLEM - INTERNAL HONING IS REQUIRED TO ACHIEVE THE SURFACE FINISHES AND TOLERANCES REQUIRED FOR RECOIL CYLINDERS. HONING IS EXTREMELY TIME CONSUMING AND ALSONOISY.

SOLUTION - REPLACE INTERNAL HONING WITH BALL SIZING ON RECOILMECHANISMS. BY FORCING A BALL (WITH A DIAMETER SLIGHTLY LARGER THAN THE DIAMETER OF THE CYLINDER) THROUGH THE CYLINDER, THE SURFACE FINISH AND TOLERANCE CRITERIA CAN BE ACHIEVED.

(8239) TITLE - IMPROVED MACHINING PROCEDURES FOR RAILS

250

PROBLEM - CURRENTLY THE DOVETAIL CONFIGURATION ON THE RAILS IS MILLED WITH A SERIES OF HIGH SPEED STEEL FORM MILLS. THESE MILLS REQUIRE A GREAT DEAL OF SHARPENING, AND THIS CHANGES THEIR SIZE THIS COMPOUNDING THE PROBLEM OF MAINTAINING ALIGNMENT.

SOLUTION - A 60 PERCENT REDUCTION IN MANUFACTURING TIME COULD BE REALIZED USING THE LATEST CONCEPTS IN MACHINE TOOLS. THESE INCLUDE CROSS AXIAL MOVEMENTS AND A METHOD OF HIGH SPEED MILLING USING INDEXABLE CARBIDE INSERTS.

(8361) TITLE - SPRAY AND FUSE PROCESS TO RECLAIM RECOIL PISTONS

190

COMPONENT -- TUBES

(7309) TITLE - REPLACEABLE STEEL LINERS FOR CANNON TUBES

250

PROBLEM - TUBE LIFE IN SEVERAL HIGH PERFORMANCE CANNONS SUCH AS THE 155MM HOW M199 AND OTHERS IS LIMITED BY EROSION AND LOSS OF ACCURACY IN A RELATIVELY FEW ROUNDS AT MAXIMUM CHARGE.

SOLUTION - DEVELOP MFG. PROCESS FOR FABRICATION OF THIN LINERS AND PROCESS FOR PLACING THESE LINERS IN CANNON TUBES, THEREBY EXTENDING CANNON LIFE.

(7916) TITLE -- APPLICATION OF LOW COST MANDREL MATERIALS

168

PROBLEM - TO PRODUCE A SATISFACTORY SUBSTITUTE FOR TUNGSTEN CARBIDE MANDREL TO ELIMINATE SOLE SOURCE PROCUREMENT. THE PRICE OF THE MANDRELS HAS INCREASED FIFTY PERCENT OVER THE LAST 5 YEARS.

SOLUTION - HIGH SPEED STEEL MANDRELS HAVE BEEN USED FOR SWAGE PROCESS IN UNITED KINGDOM. THIS SHOULD BE A SUBSTITUTE FOR TUNGSTEN CARBIDE MANDRELS.

COMPONENT -- TUBES

(CONTINUED)

(7920) TITLE - CONSERVATION OF CRITICAL MATERIALS FOR GUN TUBES

236

PROBLEM - GUN STEEL REQUIRES ALLOY SUCH AS CHROMIUM WHICH IS BECOMING IN SHORT SUPPLY AND WHICH MUST BE OBTAINED FROM OUT OF COUNTRY AND FROM A RELATIVELY FEW NATIONS. THERE IS A NEED FOR MATERIALS AND PROCESSES WHICH USE LESS OF CRITICAL ELM SUCH AS CHROMIUM.

SOLUTION - ALLOY STEEL VARIATIONS WHICH REPLACE CHROMIUM WITH BORON AND MOLYBDENUM HAVE BEEN DEVELOPED BUT HAVE PROCESSING PROBLEMS. THIS PROJECT WILL GENERATE PROCESS MODIFICATIONS TO ALLOW USE OF STEELS WITH LESS CRITICAL ALLOYS.

(7925) TITLE - BORE EVACUATOR BORING

111 248

PROBLEM - BOTH ENDS OF THE BORE EVACUATOR HAVE SIMILAR DIAMETER BORES AND REQUIRE ALMOST EQUAL MACHINING WITH HIGH COST OF MACHINING TIME. REDUCTION OF MACHINING TIME IS IMPERATIVE. ORIENTATION OF THE BORES IS IN RELATION TO EACH OTHER.

SOLUTION - A SPECIAL PURPOSE MACHINE AND TOOLING PKG PROVIDING A HEAD FOR EACH END OF THE EVAC CHAMBER CAN BE DEVELOPED TO PRODUCE BOTH BORES SIMULTANEOUSLY. IF BOTH SURFACES WERE PRODUCED FROM THE SAME SET UP. ORIENTATION OF CENTERLINES WOULD BE AUTO ASSURED.

(8024) TITLE - HIGH SPEED ABRASIVE BELT GRINDING

324

140

PROBLEM - SLIDE SURFACE DIAMETER AND FINISH IS PRESENTLY PRODUCED ON CYLINDRICAL GRINDING MACHINES USING ABRASIVE WHEELS. THE TIME IT TAKES FOR THIS OPERATION CAN BE SIGNIFICANTLY REDUCED.

SOLUTION - ABRASIVE BELT GRINDING DEPENDING ON ITS APPLICATION HAS METAL REMOVAL RATES WHICH CAN EXCEED MILLING OR GRINDING AT THE SAME TIME PRODUCING EXCELLENT TOLERANCES AND SURFACE FINISH.

(8047) TITLE - PASS THRU STEADY RESTS FOR TUBE TURNING

139

269

PROBLEM - ROLLER RESTS PROVIDE NECESSARY SUPPORT FOR GUN TUBE TURNING BUT IT WILL NOT ALLOW TURNING FULL LENGTH IN 1 SET UP. PRESENT METHOD IS TO USE 2 LATHES WITH 2 SET UPS OR LATHE MUST HAVE 2 CARRIAGES.

SOLUTION - A PASS THRU REST WILL ALLOW THE CARRIAGE TO MOVE FROM ONE SUPPORTED AREA OF THE TUBE TO THE OTHER WITHOUT DISTURBING THE SETUP. THE DESIGN WILL BE APPLICABLE TO CURRENTLY AVAILABLE EQUIP BUT WILL HAVE EVEN GREATER IMPACT ON NEW EQUIP ACQUISITIONS.

(8050) TITLE - RECYCLING SPENT GUN TUBES BY ESR MELTING

201

PROBLEM - BECAUSE OF ANTICIPATED SHORTAGES IN THE AVAILABILITY OF CRITICAL ALLOYS, IT IS ADVANTAGEOUS TO UTILIZE SPENT GUN TUBES.

SOLUTION - TUBES WHICH CANNOT BE DIRECTLY ROTARY FORGED MIGHT BE REMELTED DIRECTLY BY ESR INTO INGOTS FOR USE ON THE ROTARY FORGE.

COMPONENT -- TUBES

(CONTINUED)

(8057) TITLE - DUAL RIFLING BROACH REMOVAL SYSTEM

215

PROBLEM - PRESENT RIFLING EQUIPMENT REQUIRES MANUAL REMOVAL OF BROACHES. AFTER EACH OF APPROXIMATELY 32 PASSES THE OPERATOR MUST WALK FROM THE OPERATORS STATION TO THE FAR END OF THE GUN TUBE TO REMOVE THE BROACHES.

SOLUTION - DEVELOP AN AUTOMATIC BROACH REMOVAL DEVICE WHICH WILL REDUCE OPERATIONAL TIME, SAFETY HAZARDS, AND OPERATOR FATIGUE.

(8060) TITLE - IMP MFG PROCESSES RELATED TO FINAL INSPECTION

268

PROBLEM - THE CURRENT INSPECTION PROCESS FOR GUN TUBES IS SLOW AND AWKWARD.

SOLUTION - DEVELOP AN INSPECTION PROCESS WHICH USES MECHANIZATION AND NEW TECHNOLOGY.

(8103) TITLE - HIGH VELOCITY MACHINING

36

414

94

PROBLEM - SPEED OF MACHINING CANNON TUBES IS LIMITED WITH CURRENT EQUIPMENT.

SOLUTION - EVALUATE HIGH SPEED METAL REMOVAL METHODS AND AVAILABLE EQUIPMENT. FUTURE YEARS FUNDING WILL PROVIDE FOR ACQUISITION AND TESTING OF NEW MACHINE AND PROCESS.

(8106) TITLE - LARGE CALIBER POWDER CHAMBER BORING

59

159

71

PROBLEM - POWDER CHAMBERS PRODUCTION ON LARGE BORE CANNON 8#M201 CURRENTLY REQUIRES 14 HRS TO ACCOMPLISH BOTH ROUGH AND FINISH OPERATIONS.

SOLUTION - PERFORM THE FINISHING OPERATION IN THE SAME SETUP AS THE ROUGHING OPERATION BUT USING AS A CUTTING MEDIA DIAMOND FINISHING TOOLS WHICH AT VERY HIGH SPEEDS PRODUCE EXCELLENT SURFACE FINISH. THIS PROCESS WOULD ELIMINATE ONE GRINDING OPERATION.

(8107) TITLE - CREEP FEED CRUSH FORM GRINDING

82

579

73

PROBLEM - THE BRACKET SLOT ON THE 105MM M68 BREECH RING IS A HIGH COST OPERATION. IT IS CURRENTLY MILLED WITH FORM TOOLS IN TWO OPERATIONS-ROUGH AND FINISH.

SOLUTION - A NEW PROCESS IS BEING DEVELOPED THAT RESEMBLES THE CRUSH FORM ABRASIVE MACHINE FOR CYLINDRICAL PARTS EXCEPT THAT THE PROCESS IS USED TO PRODUCE FLAT CONTOURED SURFACES. IT IS PROPOSED THIS PROCESS BE ADAPTED TO PRODUCTION OF THE BRACKET SLOT.

MMT FIVE YEAR PLAN  
RCS DRCMT 126

FUNDING (\$000)

PRIOR 80 81 82 83 84

COMPONENT -- TUBES

(CONTINUED)

(8151) TITLE - PORTABLE ENGRAVING SYSTEM

84 168

PROBLEM - CURRENTLY THE COMPONENT IDENTIFICATION LEGEND IS STAMPED BY HAMMER AND INDIVIDUAL ALPHA-NUMERIC STAMPS. THIS IS A TIME CONSUMING PROCESS WITH NO DEPTH CONTROL AND CAN PRESENT A SAFETY HAZARD TO PERSONNEL.

SOLUTION - PROVIDE A PROGRAMMABLE DATA ENGRAVING SYSTEM TO RELIEVE THE OPERATOR OF THE FATIGUE AND HAZARD OF HAND STAMPING. THIS WILL RESULT IN MORE UNIFORM SPACING AND DEPTH CONTROL AND REDUCE BOTH TIME AND COST.

(8152) TITLE - IMPROVED ANODE STRAIGHTNESS FOR CHROMIUM PLATING

280

PROBLEM - ANODE STRAIGHTNESS AND RIGIDITY ARE IMPORTANT FOR MAXIMUM AND UNIFORM RADIAL DISTRIBUTION OF CURRENT. A SOLID COPPER ROD IS PRESENTLY USED. ALTHOUGH ANODES ARE MADE AND PRESERVED AS CAREFULLY AS POSSIBLE STRAIGHTNESS IS A RECURRING PROBLEM.

SOLUTION - THIS PROJECT WILL USE IN THE COPPER ANODES A COMMERCIALY AVAILABLE COMPOSITE ROD MADE OF UNIDIRECTIONAL GRAPHITIC FILAMENTS IN A SUITABLE MATRIX. THE SPECIFIC STRENGTH WILL BE 33 TIMES HIGHER AND THE SPECIFIC MODULUS 9 TIMES HIGHER THAN COPPER.

(8153) TITLE - INCREASING GUN TUBE HEAT TREATMENT CAPACITY

336

PROBLEM - OIL-FIRED SELAS CONTINUOUS HEAT TREATING CANNOT MEET THE PRODUCTION CAPACITY OF THE ROTARY FORGE. THE OUTPUT OF THE HEAT TREAT LINE MUST BE INCREASED THREE-FOLD TO MEET MOBILIZATION REQUIREMENTS.

SOLUTION - INCREASE CAPACITY BY MODIFYING PRESENT SYSTEM, ADDING SECOND MODIFIED SYSTEM, ADDING A STABILIZING FURNACE, AND SHORTENING AUSTENITIZATION CYCLE. ANOTHER POSSIBILITY IS TO USE RAPID HEATING RATES AVAILABLE WITH INDUCTION HEATING TO REDUCE TIME NEED.

(8208) TITLE - MATERIAL HANDLING

113

PROBLEM - A STUDY MADE ON THE 105MM M68 GUN TUBE PRODUCTION LINE REVEALED 12% OF TIME TO PRODUCE THE TUBE WAS "CONSUMED IN MOVING THE TUBE ABOUT" ANOTHER 20% OF THE MFG TIME SPENT IN MAKING THE TUBE READY AND TAKING THE TUBE DOWN FROM THE MACHINES.

SOLUTION - ONE METHOD TO REDUCE THE HANDLING TIME AND TERMINAL (POSITIONING AND REMOVING) TIME WOULD BE TO DEVELOP NEW EQUIPMENT FOR POSITIONING LIFTING AND TRANSFERING OF GUN TUBES AND COMPONENTS.

COMPONENT -- TUBES

(CONTINUED)

(8241) TITLE - COMPUTER APPLICATIONS TO BORE GUIDANCE

303 76 100

PROBLEM - THE BORE GUIDANCE SYSTEM CONSISTS OF MANY INTERDEPENDENT ELEMENTS MAKING IT DIFFICULT AND TIME CONSUMING TO DIAGNOSE PROBLEMS. ALSO, TUBES WITH LARGE WALL VARIATIONS GREATLY INCREASE THE DIFFICULTY IN MAINTAINING CONTROL.

SOLUTION - COMPUTER CONTROL WILL MAKE POSSIBLE SUCH FEATURES AS SELF TESTING, CHECKING, MONITORING, AND CALIBRATION IN CONTROL, TEST, AND MEASUREMENT SYSTEMS.

(8242) TITLE - DUAL PRESS LOADING

118

PROBLEM - ABOUT 20 PCT OF GUN TUBE FORGINGS REQUIRE STRAIGHTENING AT TEMPERATURES ABOVE 600 DEG F BECAUSE THE CRITERIA FOR "COLD" STRAIGHTENING ARE RELATIVELY TIGHT. SINGLE LOADING INDUCES STRESSES THAT CREATE MACHINING PROBLEMS.

SOLUTION - A TWO POINT LOADING DEVICE WILL BE DESIGNED WHICH WILL APPLY LOADS AT TWO POINTS THUS REDUCING INDUCED STRESSES

(8243) TITLE - COMPUTER CONTROLLED CHROMIUM PLATING PROCESS

296 255

PROBLEM - CHROMIUM PLATING OF CANNON BARRELS IS A COMPLICATED, MULTI-STAGE PROCESS WHICH IS MANUALLY CONTROLLED. MANUAL MANIPULATION OF VALVE STRESS, SWITCHES, ETC., IS SLOW, SOMETIMES HAZARDOUS, AND CAN RESULT IN DEGRADED DEPOSIT QUALITY DUE TO HUMAN ERROR.

SOLUTION - THE CRITICAL STAGES OF THE CHROMIUM PLATING PROCESS WILL BE IDENTIFIED AND A PROGRAMMABLE CONTROLLER(S) DEVELOPED TO REDUCE TO NEAR ZERO THE MANIPULATION FUNCTIONS REQUIRED OF AN OPERATOR.

(8244) TITLE - OPTIMIZATION OF HEAT TREAT

286

PROBLEM - ROTARY FORGED TUBES ARE CURRENTLY HEAT TREATED BASED ON HISTORICAL DATA. IF THE INITIAL CYCLE DOES NOT RESULT IN ADEQUATE PROPERTIES ADDITIONAL CYCLES ARE PERFORMED UNTIL ACCEPTABLE PROPERTIES ARE ATTAINED.

SOLUTION - INFORMATION ON EACH PREFORM TOGETHER WITH HISTORICAL DATA WILL BE USED TO DEVELOP A COMPUTER PROGRAM TO GENERATE HEAT TREAT PARAMETERS. THIS WILL GREATLY INCREASE THE PROBABILITY THAT THE REQUIRED PROPERTIES WILL BE OBTAINED ON THE FIRST CYCLE.

(8245) TITLE - LOW CONCENTRATION (LC) CHROMIUM PLATING

237 191

PROBLEM - HIGH CONCENTRATION CHROMIUM COATING IS CURRENTLY USED TO RESIST EROSION IN GUN BORES. INHERENT PROPERTIES MAKE THE COATING SUSCEPTABLE TO SHEARING AND FLAKING.

SOLUTION - PLATING WITH LOW CONCENTRATION CHROMIUM WILL GIVE A MARKED INCREASE IN WEAR RESISTANCE DUE TO ITS SUPERIOR CHARACTERISTICS.

COMPONENT -- TUBES

(CONTINUED)

(8246) TITLE - IMPROVED FINISHING OF GAS CHECK SEATS 151

PROBLEM - MACHINING OF GAS CHECK SEATS IS A PRECISION PROCESS INVOLVING GRINDING AND LAPPING OF A CRITICAL AREA OF THE CANNON WHICH RESULTS IN 30 TO 50 PERCENT REWORK TO PASS CONTACT GAGE REQUIREMENTS.

SOLUTION - APPLY MORE PRECISE ALIGNMENT OF FINISHING EQUIPMENT AND ELIMINATE THE MACHINING FACILITY WHICH TENDS TO INDUCE ECCENTRICITY. THE GAUGING SYSTEM WILL ALSO BE REVIEWED.

(8259) TITLE - MACH/MARKING OF FIRE CONTROL REGISTERS 257

PROBLEM - DIFFICULTY IN MEASURING AND CORRECTLY MARKING THE FIRE CONTROL REGISTER, ON VARIOUS MID CALIBER WEAPON SYSTEMS, INDICATING COMPENSATION FOR MANUFACTURING VARIANCE DUE TO TOLERANCE ALLOWANCES.

SOLUTION - PROVIDE AN ANALOG LEVELING MEASURING SYSTEM WHICH WILL PROVIDE INPUT DATA FOR A SERVOCONTROLLED JACKING SYSTEM TO POSITION LEVEL A TUBE AT THE MUZZLE END AND A MEASURING SYSTEM FOR THE VARIATIONS AT THE BREECH LEVELING SITE.

(8341) TITLE - HOLLOW CYLINDER CUT OFF MACHINE 600

PROBLEM - ESTAB. CYL LENGTH IS DONE 1 OF 2 WAYS. PARTED OFF IN A LATHE AND FACED TO LENGTH OR SAWED OFF AND THEN SET UP IN A LATHE FOR FACING TO FINAL LENGTH DIMENSIONS. IN EITHER CASE, THE OPERATION REQUIRES DOUBLE HANDLING OR SLOW OPERATING PROCEDURES.

SOLUTION - NEW TECHNOLOGY IS BEING DEVELOPED WHEREBY A SET OF ROTATING CUTTERS MILLS THE CYLINDER TO LENGTH PRODUCING A FACE SURFACE TO SATISFY OUR TUBE LENGTH REQUIREMENTS CURRENT MACH. DESIGN WILL NOT PERFORM THIS FUNCTION BUT THE TECHNOLOGY IS APPLICABLE.

(8342) TITLE - KEYWAY MILLING MACHINE 242

PROBLEM - 155MM M185 REQUIRES 3 KEYWAYS BE MILLED ON C/L TO CLOSE DIMENSIONS AND TOLERANCES. PRESENTLY MILLED IN 3 DIFFERENT MACHINES REQUIRING 3 SET UPS AND 3 MOVES.

SOLUTION - A SPECIAL PURPOSE KEYWAY MILLING MACHINE WILL BE DEVELOPED TO HOLD THE TUBE ON LOCATION AND MILL ALL 3 KEYWAYS SIMULTANEOUSLY. ALIGNMENT OF ALL KEYWAYS TO C/L WOULD BE ASSURED.

(8343) TITLE - LASER CUTTING OF CANNON TUBES 251

PROBLEM - AN INORDINATE AMOUNT OF TIME IS REQUIRED TO PERFORM CUTTING AND REMOVAL OF EXCESSIVE MATERIAL FROM GUN TUBES.

SOLUTION - A LASER MACHINING PROCESS WITH SUFFICIENT OUTPUT ENERGY TO ACCOMMODATE LARGE WALL THICKNESSES WILL BE DEVELOPED.

COMPONENT -- TUBES

(CONTINUED)

(8344) TITLE - PARTIAL REFRACTORY LINERS FOR CANNON TUBES 250 400

PROBLEM - MANUFACTURING PROBLEMS ARE ASSOCIATED WITH THE FABRICATION, MACHINING, AND ASSEMBLY OF THIN REFRACTORY LINERS INTO CANNON TUBES.

SOLUTION - DEVELOP NEW TECHNIQUES AND MANUFACTURIN PROCESSES TO SOLVE THESE PROBLEMS.

(8421) TITLE - CONTOUR CHEMICAL MILLING PROCESS FOR GUN TUBE FAB. 278

\*\*\*\*\*  
\* C A T E G O R Y \*  
\*-----\*  
\*QUALITY CONTROL/TESTING \*  
\*\*\*\*\*

COMPONENT -- GUN SYSTEMS

(8036) TITLE - WEAPON AIMING SYSTEM FOR THE 6-DOF SIMULATOR 126

PROBLEM - THE EXISTING PHYSICAL SIMULATION FACILITY FOR EVALUATION AND TESTING OF WEAPONS, STABILIZATION AND FIRE CONTROL SYSTEMS IS NOT CAPABLE OF FULLY TESTING THESE SYSTEMS BECAUSE THE PRESENT AIMING SYSTEM IS INADEQUATE FOR LARGE AMPLITUDE MOTIONS.

SOLUTION - DEVELOP A WEAPON AIMING SYSTEM IN WHICH THE GUNNERS LINE OF SIGHT IS INDEPENDENT OF HULL MOTIONS INDUCED BY THE SIMULATOR, AND WHICH PROVIDES A REMOTE CONTROL AND DISPLAY CAPABILITY TO THE GUNNER.

(8136) TITLE - IMPROVE IMPULSE PROGRAMMER FOR HYDRAULIC SIMULATOR 80

PROBLEM - UNDESIRABLE SHOCK AND VIBRATION IN TESTS OF CERTAIN RECOIL MECHANISMS LIMIT THE EXTENT OF TESTING THAT CAN BE ACCOMMODATED ON THE HYDRAULIC ARTILLERY TEST SIMULATOR.

SOLUTION - DESIGN AND MANUFACTURE IMPROVED IMPULSE PROGRAMMERS TO GET BETTER SIMULATED FIRING THAT WILL BE MORE EFFECTIVE FOR A GREATER NUMBER OF WEAPONS.

(8235) TITLE - AUTOMATIC ADJUSTMENT FOR SIMULATOR ARTILLERY TEST 250 100

PROBLEM - HIGH OPERATING COSTS DUE TO NECESSITY OF MANUAL ADJUSTMENT OF VALVES AND OF SPACING BETWEEN SIMULATOR AND WEAPON.

SOLUTION - PROVIDE INCREASED TEST EFFICIENCY BY PROVIDING REMOTE AND AUTOMATIC ADJUSTMENT OF SIMULATOR SPACING TO WEAPON, AND FOR AUTOMATIC ADJUSTMENT OF PRECHARGE PRESSURES.

COMPONENT -- MISCELLANEOUS

(8253) TITLE - MACHINE TOOL DYNAMIC MEASUREMENTS AND DIAGNOSTICS 187

PROBLEM - VIBRATIONS IN MACHINE TOOLS, KNOWN AS CHATTER, CAN BE THE CAUSE OF POOR MACHINING OPERATIONS WHICH, IN A HIGH PRODUCTION ENVIRONMENT, CAN RESULT IN MUCH LOST TIME AND DOLLARS.

SOLUTION - DEVELOP A MACHINE TOOL DYNAMIC MEASUREMENTS TECHNIQUE WHICH USES VIBRATION SIGNALS RECEIVED FROM VARIOUS MACHINE LOCATIONS AND IDENTIFIES THE ORIGIN AND MAGNITUDE OF THE VIBRATION. VIBRATION ANALYSIS WOULD INDICATE CORRECTIVE ACTION.

(8370) TITLE - AUTOMATED INSPECTION OF WEAPONS COMPONENTS 210 360

\*\*\*\*\*  
\* C A T E G O R Y \*  
\*-----\*  
\*SMALL CALIBER \*  
\*\*\*\*\*

COMPONENT -- BARRELS

(7985) TITLE - SMALL ARMS WEAPONS NEW PROCESS PRODUCTION TECHNOLOGY 350 436 512 667 239

PROBLEM - GUN BARREL MFG PROCEDURES REFLECT ANTIQUATED TECHNOLOGY AND RELY ON MASS REMOVAL OF MATERIAL BY CONVENTIONAL MACHINING METHODS. CURRENT EQUIP REPRESENTS 1940-50 TECHNOLOGY. NEW MATERIALS COMPOUND THE PROBLEM.

SOLUTION - REDUCE TO PRACTICE NEW TECHNIQUES FOR CAL 50 TO 40MM BARRELS BY ESTABLISHING THE TECHNOLOGY AND PROCESS EQUIPMENT REQUIRED TO BRIDGE GAP BETWEEN CAPABILITIES AND REQUIREMENTS.

(8001) TITLE - RAPID FLOW PLATING OF SMALL CAL GUN TUBES 132

PROBLEM - CHROMIUM PLATING IS A RELATIVELY SLOW PROCESS.

SOLUTION - RAPID SOLUTION FLOW GREATLY INCREASES PLATING RATE.

(8162) TITLE - IMPROVED SC GUN BARREL RIFLING MFG TECHNIQUES 246

PROBLEM - RIFLING SMALL CALIBER GUN BARRELS USES ANTIQUATED TECHNOLOGY (C. 1940-50). AS MANY AS 24 PASSES WITH WAFER TYPE BROACHES ARE NEEDED. EACH PASS REQUIRES DISASSEMBLY OF SET-UP. EQUIPMENT IN CAL. 50 TO 40MM SIZE IS EXTREMELY LIMITED.

SOLUTION - APPLY AND REDUCE TO PRACTICE THE CONCEPT OF ULTRASONIC EXCITATION OF RIFLING FORMING TOOLS. THE USE OF ULTRASONICS FOR RIFLE FORMING WILL RESULT IN REDUCED FORCES TO FORM RIFLING, IMPROVED FINISH CHARACTERISTICS, AND REQUIRE FEWER PASSES.

FUNDING (\$000)

PRIOR 80 81 82 83 84

COMPONENT -- BARRELS (CONTINUED)

(8164) TITLE - HIGH SPEED MACHINING OF SC WEAPONS COMPONENTS 260 250

PROBLEM - MACHINING SMALL CALIBER WEAPONS COMPONENTS BY CONVENTIONAL METHODS REQUIRES CONSIDERABLE TIME AND IS THE MAIN PORTION OF ITEM COST. ALSO, INDIVIDUAL MACHINE OPERATIONS ARE PERFORMED ON SEPARATE MACHINES REQUIRING EXTENSIVE MANUAL HANDLING.

SOLUTION - HIGH SPEED METAL REMOVAL AND THE COMBINATION OF OPERATIONS FOR STEEL COMPONENTS OF SMALL CALIBER WEAPONS WILL BE INVESTIGATED. BENEFITS INCLUDE REDUCED TIME AND COST, IMPROVED TOOL LIFE, AND IMPROVED SURFACE FINISH.

(8266) TITLE - INVESTMENT CAST LINERS OF SUBSTITUTE ALLOYS 293 200

PROBLEM - AN ALTERNATE INVESTMENT-CAST GUN TUBE LINER MATERIAL IS REQUIRED TO SERVE AS A BACKUP AND/OR REPLACEMENT FOR THE CURRENT STRATEGIC COBALT-BASE INVESTMENT CAST ALLOY.

SOLUTION - ESTABLISH VACUUM MELTING AND CASTING CAPABILITIES FOR THE INVESTMENT CASTING OF GUN TUBE LINERS.

(8472) TITLE - ROTARY FORGING OF GUN BARRELS 275

COMPONENT -- GENERAL

(8051) TITLE - APPLICATION AND CONTROL OF MACHINE TOOLS 100 85

PROBLEM - CURRENT PROCEDURES FOR THE JUSTIFICATION, SELECTION, APPLICATION, AND MAINTENANCE OF MACHINE TOOLS ARE INADEQUATE TO AVOID PROCUREMENT OF INEFFICIENT, UNRELIABLE MACHINE TOOLS.

SOLUTION - ESTABLISH AN ACCURATE DEFINITION OF MACHINE TOOL REQUIREMENTS IN RELATION TO COMPONENT MACHINING REQUIREMENTS. DEVELOP PERFORMANCE ANALYSES AND COMPETITIVE PERFORMANCE EVALUATION CRITERIA.

(8163) TITLE - PM STEEL PREFORMS FOR SMALL CALIBER WEAPONS 180

PROBLEM - MANUFACTURE OF WEAPONS COMPONENTS SUCH AS BOLTS AND SPROCKETS HAVE BEEN BY CONVENTIONAL METAL REMOVAL PROCESSES. WHILE NC EQUIPMENT REDUCES MACHINING TIMES, EQUIPMENT COSTS ARE HIGH AND MUCH MATERIAL WASTE OCCURS.

SOLUTION - P/M OFFERS A MEANS OF ACHIEVING NEAR NET SHAPE AT LOW COST. P/M PREFORM APPROACH HAS BEEN SHOWN FOR SIMPLE SHAPES. RECENT ADVANCES IN P/M TECHNOLOGY HAVE DEMONSTRATED THE CAPABILITY OF MANUFACTURING P/M PREFORMS IN COMPLEX SHAPES.

(8366) TITLE - NON-TRADITIONAL MACHINE-FORMING OF SMALL CAL COMPONENTS 396

(8468) TITLE - ASSEMBLY & HANDLING TECHNIQUES FOR SMALL CAL WEAPONS 320

MMT FIVE YEAR PLAN  
RCS DRCMT 126

FUNDING (\$000)

PRIOR 80 81 82 83 84  
-----

COMPONENT -- SPRINGS

(8267) TITLE - STRESS PEENING OF HELICAL COMPRESSION SPRING

160

PROBLEM - THE FATIGUE LIFE AND RELIABILITY OF CRITICAL SPRINGS IN SOME WEAPON SYSTEMS IS LESS THAN DESIRABLE.

SOLUTION - IMPROVE THE FATIGUE LIFE AND RELIABILITY OF THE WEAPON SPRINGS BY OPTIMIZING THE PRODUCTION PROCESS PARAMETERS SUCH AS SHOT SIZE, SHOT INTENSITY, AND SPRING STRESS LEVEL.

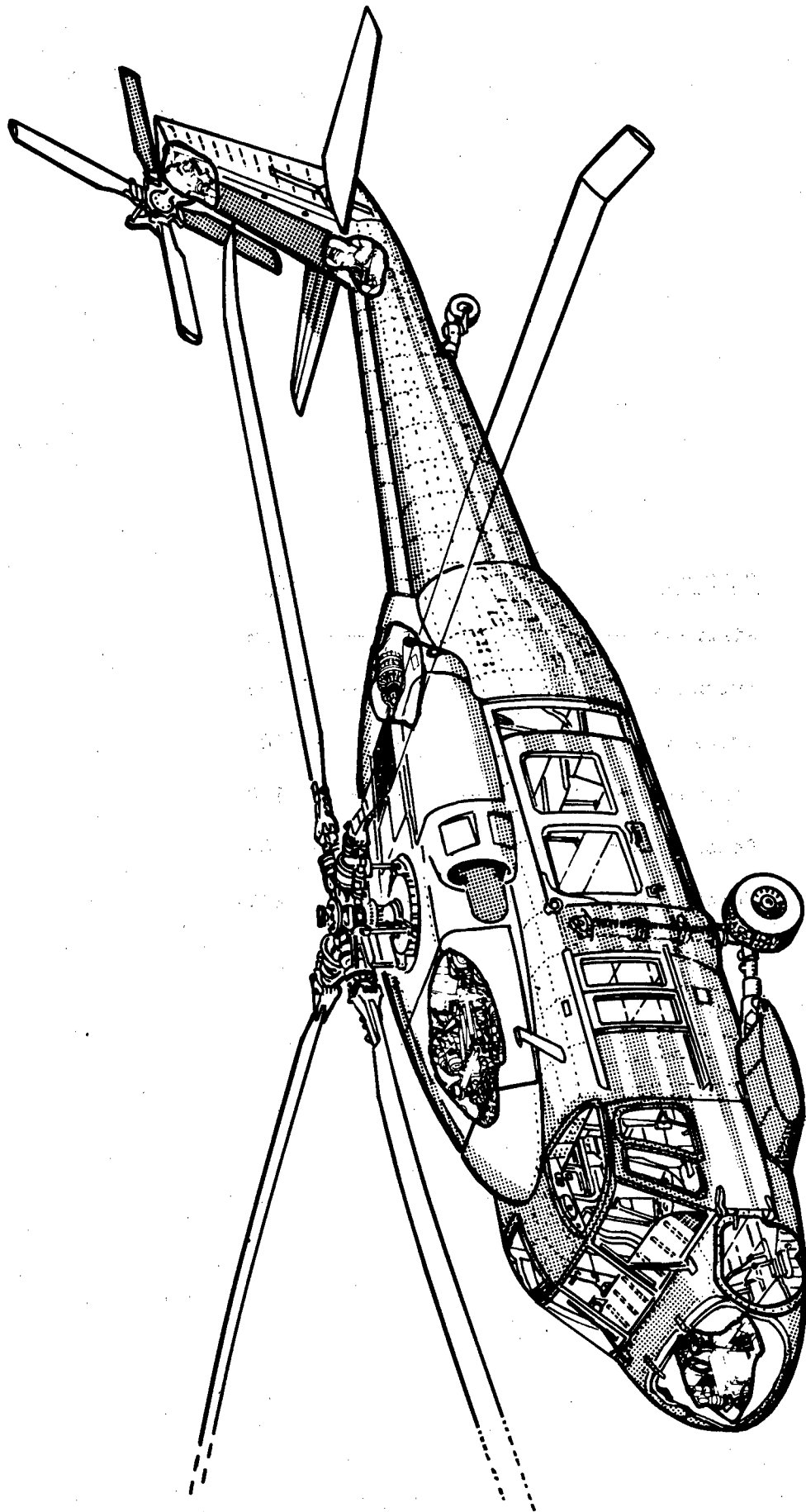

**AVIATION R&D COMMAND  
(AVRADCOM)**

<u>CATEGORY</u>	<u>PAGE</u>
Airframe -----	98
Avionics -----	103
Drive System -----	104
General -----	108
Rotor System -----	109
Turbine Engine -----	112

US ARMY AVIATION RESEARCH AND DEVELOPMENT COMMAND

(AVRADCOM)

The US Army Aviation Research and Development Command (AVRADCOM), with headquarters at St. Louis, MO, is responsible for Army aviation research, development, product improvement, acquisition for assigned materiel and research projects, initial procurement, and production. The Command directs the Research and Technology Laboratories with headquarters at NASA - Ames Research Center, Moffett Field, CA; US Army Avionics Agency and Laboratory, Fort Monmouth, NJ; US Army Bell Plant Activity, Fort Worth, TX; US Army Hughes Plant Activity, Culver City, CA; and three project managers: Aircraft Survivability Equipment, CH-47 Modernization Program, and Navigation/Control Systems. PM Advanced Attack Helicopter (AAH) and PM Blackhawk are collocated with AVRADCOM, but are under the direct control of HQ, DARCOM.

The most important criteria of aircraft material are strength and low weight. A large part of the aviation MMT program is the attempt to replace metals with materials having better strength to weight ratios. Composite materials suitable for aviation have been developed and are being used. Composites are pound for pound less expensive than metals traditionally used in aircraft, are stronger, and do not need the extensive and expensive machining that metals do. However, techniques for the production and application of composites need further development to reach optimum efficiency and savings.

The use of composite materials in Army aircraft is anticipated to increase as current work in MT and in R&D leading toward an all-composite helicopter fuselage nears completion. In addition, raw material costs are expected to decrease with the increased use of composites in DOD and Industry. Also, as confidence increases in composites, current reservations held by designers (especially quality control segments) will be removed, and composites will be incorporated in the earliest stages of weapon development with consequent increases in necessary MMT work.

A significant portion of the funding for composites work is primarily for the establishment of manufacturing processes to support composite main and tail rotors and the tail boom for the YAH-64 Advanced Attack Helicopter (AAH). The rotor projects build upon previous Government and Industry R&D and MT work. In the case of the main rotor blade, costs will be reduced by incorporation of unique techniques that reduce cure cycles and handling. The tail rotor program will establish for the first time a manufacturing process that can be automated with consequent cost savings. The tail boom project will resolve several manufacturing problems and will make composite tail booms economically feasible with significant weight savings.

Composite projects are planned for virtually every part of the helicopter except the avionics area. Several projects are planned in the airframe area. One will establish manufacturing methods for application of composites to a main fuselage primary structure (the rear fuselage of the Blackhawk). Five projects are planned in the rotor area. The principle projects are those for the AAH, but a project is also planned for establishing a production method for the blades of the RPV. In the drive area, three projects are planned. One will focus on the drive shaft and another will result in methods for manufacturing a gearbox housing. In the engine area, a project is included for methods to fabricate the particle accelerator. The decrease in weight of this component will improve engine performance and cascading beneficial effects in the bearing and lubrication areas.

Several projects will attack technical problem areas that affect all composite manufacturing. These projects address automation of cutting and layup operations, machining, fastening, technology transfer, and new materials. The development of automation techniques will be pursued in cooperation with the Air Force, the lead service in this area.

The most significant project areas in terms of advancing composites manufacturing and usage is in the development of quality control techniques. Projects are planned in this area; they will address materials characterization, in-process controls, and non-destructive evaluation. These projects will ensure optimum processing and material performance, and increase confidence in composites.

These are many areas in aircraft in which metals can not be replaced and projects are included in this submission to improve production of these items. Since many aircraft metals used in the propulsion system are tough and expensive, machining a casting to final shape is difficult and produces costly scrap. Improving powder metal technology will give castings much closer to final shape, greatly reducing the time and effort to produce the final product. Several projects are included to implement recent advances in gear manufacturing and should provide an improved item at a lower cost. Projects are also planned to find ways of repairing rather than scrapping complex items which are damaged in the manufacturing process. An effort is planned to replace metal turbine blades with ceramic ones. This will provide better operating characteristics at lower cost.

The overall emphasis of the Army's aviation MMT program is to perfect technologies which have a good probability of implementation and high potential benefits. For the most part, efforts are directed towards projects which offer both cost reductions and product improvements. The results of these projects will be made available to other Government agencies and to Industry.

AVRADCOM

COMMAND FUNDING SUMMARY  
(THOUSANDS)

CATEGORY	FY80	FY81	FY82	FY83	FY84
-----	----	----	----	----	----
AIRFRAME	2734	3473	1020	1100	2955
AVIONICS	0	310	540	150	515
DRIVE SYSTEM	680	1695	1899	3205	3025
GENERAL	0	55	70	200	220
ROTOR SYSTEM	4127	1470	4100	800	950
TURBINE ENGINE	930	3122	6031	6550	5680
	----	----	----	----	----
TOTAL	8471	10125	13660	12005	13345

\*\*\*\*\*  
 \* C A T E G O R Y \*  
 \*-----\*  
 \*AIRFRAME\*  
 \*\*\*\*\*

MMT FIVE YEAR PLAN  
 RCS DRCHT 126

FUNDING (\$000)

PRIOR 80 81 82 83 84  
 -----

COMPONENT -- FUSELAGE STRUCTURES

(7113) TITLE - COMPOSITE REAR FUSELAGE MANUFACTURING TECHNOLOGY 250 1000 1350

PROBLEM - APPLICATION OF COMPOSITE MATERIALS TO AIRFRAME FUSELAGE COMPONENTS POSSESSES A LARGE POTENTIAL FOR COST AND WEIGHT SAVINGS. HOWEVER, PRODUCTION MANUFACTURING PROCESSES HAVE NOT BEEN ESTABLISHED FOR LARGE, FULL-SCALE, COMPOUND CURVATURE, COMPONENTS.

SOLUTION - PROJECT WILL ESTABLISH TECHNOLOGY FOR FABRICATING MOLDED COMPOSITE REAR FUSELAGE STRUCTURES, WITH EMPHASIS ON BLACKHAWK. LOW COST TOOLING, FORMING MOLDS, AND CO-CURING PROCESSES WILL BE DEVELOPED TO INSURE HIGH REPEATABILITY AND INTEGRITY.

(7338) TITLE - COMPOSITE TAIL SECTION 980 905 1090

PROBLEM - THE POTENTIAL COST AND WEIGHT ADVANTAGES OF COMPOSITES FOR AIRFRAME COMPONENTS HAVE NOT BEEN FULLY DEMONSTRATED DUE TO FABRICATION LIMITATIONS RELATED TO CONFIGURATION RESTRAINTS, FOR EXAMPLE, IN-PLACE WINDING, COMPLEX CONTOURS, AND CO-CURING.

SOLUTION - EXPERIMENTAL FABRICATION TECHNOLOGY, DEVELOPED UNDER AN R+D EFFORT, WILL BE REVIEWED AND IMPROVED AUTOMATED MANUFACTURING PROCEDURES WILL BE ESTABLISHED FOR THE YAH-64 HELICOPTOR TAIL SECTION. FILAMENT WINDING IS THE PRIMARY TECHNOLOGY INVOLVED.

(7370) TITLE - RING WRAP COMPOSITES 300

PROBLEM - LARGE IRREGULAR SHAPED OR LONG AIRFOIL PROFILES PRESENT SPECIAL PROBLEMS WHEN ATTEMPTS ARE MADE TO FILAMENT WIND THESE CONFIGURATIONS.

SOLUTION - A ROTATING RING STRUCTURE, CONTAINING FILAMENT SPOOLS AND POSITIONING EYES, WILL BE DEVELOPED. IT WILL ORBIT THE STATIONARY MANDREL DISPENSING AND POSITIONING THE FILAMENT MATERIAL.

(7387) TITLE - LOW COST RADAR CAMOUFLAGE AIRFRAME MATERIAL 100

PROBLEM - CURRENT CONST TECH FOR INTEGRAL RADAR CAMOUFLAGED, LOAD BEARING AIRFRAME MATERIALS REQUIRE LABOR INTENSIVE SECONDARY FABRICATION STEPS FOR INTEGRATING CAMOUFLAGED COMPONENTS INTO AIRFRAME STRUCTURES.

SOLUTION - DEVELOP MATERIALS AND CONSTRUCTION TECHNIQUES WHICH PERMIT DIRECT INCORPORATION OF CAMOUFLAGE MATERIALS WITHIN THE COMPOSITE STRUCTURE. THIS WILL REDUCE THE OVERALL COST OF THE AIRFRAME STRUCTURE.

COMPONENT -- GENERAL

(7302) TITLE - PROD OF TIB2 COATED LONG LIFE TOOLS

200 60

PROBLEM - AIRFRAME COMPONENTS AND PRINTED CIRCUIT BOARDS OF FIBERGLASS AND OTHER COMPOSITES ARE DIFFICULT TO MACHINE. TOOL LIFE IS 5-10 PCT COMPARED TO USE ON TITANIUM WORKPIECES. TITANIUM DIBORIDE (TIB2) COATED TOOLS ARE BETTER BUT NOT ECONOMICAL.

SOLUTION - MANUFACTURE OF TIB2 COATED TOOLS WILL BE SCALED UP FROM LAB-SIZED ELECTROLYTIC CELLS (15 LBS) TO PRODUCTION SIZE (ABOUT 300 LBS) WITH THE CAPABILITY TO PLATE VARIOUS TOOL TYPES AND SHAPES. TOTAL TOOLING COST WILL BE ABOUT 20 PCT OF CURRENT.

(7341) TITLE - STRUCTURAL COMPOSITE FABRICATION GUIDE

70 73

PROBLEM - THE NEED EXISTS TO DOCUMENT INDUSTRY EXPERIENCE IN COMPOSITES SO THAT COST AND MANUFACTURING COMPARISONS CAN BE MADE.

SOLUTION - THE GUIDE WILL PROVIDE INFORMATION IN A SYNERGISTIC FASHION TO PROVIDE PRODUCTION ANALYSIS, PROVIDE PROCESS/COST INTERRELATIONSHIPS AND PROMOTE A THOROUGH MANUFACTURING INTERFACE.

(7358) TITLE - RADAR CAMOUFLAGED PANEL COMPONENT PRODUCTION

150 200

PROBLEM - CERTAIN COMPONENTS USED IN RADAR CAMOUFLAGED PANELS ARE MANUFACTURED IN SMALL BATCHES AND SMALL WIDTHS UNSUITABLE FOR FULL SIZE AIRCRAFT. AUTOMATED METHODS EXIST FOR SIMILAR MATERIALS, HOWEVER THEY ARE NOT BEING USED FOR RADAR CAMOUFLAGED PANELS.

SOLUTION - FABRICATION TECHNIQUES ALREADY WELL DEVELOPED AND WELL KNOWN IN INDUSTRY WILL BE ADAPTED TO THESE COMPONENTS AND TO THE TOLERANCES NECESSARY, THUS REPLACING THE CURRENT HAND LAY-UP TECHNIQUES.

COMPONENT -- MISC COMPONENTS

(7240) TITLE - MACHINING METHODS FOR ESR 4340 STEEL

192 124

PROBLEM - MANY CRITICAL HELICOPTOR PARTS REQUIRE HIGH BALLISTIC TOLERANCE CHARACTERISTICS. THESE COMPONENTS ARE BEING FABRICATED FROM ESR 4340 STEEL. HOWEVER, THE MACHINING OF THIS NEW MATERIAL IS NOT CLEARLY DEFINED AND, THEREFORE, IS OVERLY EXPENSIVE.

SOLUTION - MACHINING METHODS WILL BE INVESTIGATED TO ESTABLISH THE TECHNIQUES NECESSARY TO EFFICIENTLY FABRICATE COMPONENTS FROM ESR 4340. BOTH CONVENTIONAL AND UNCONVENTIONAL APPROACHES WILL BE PURSUED.

PRIOR 80 81 82 83 84  
-----

COMPONENT -- MISC COMPONENTS

(CONTINUED)

(7243) TITLE - MACHINING OPERATIONS ON KEVLAR LAMINATES

14 150

PROBLEM - PRESENT METHODS OF MACHINING KEVLAR LAMINATES TEND TO CAUSE DELAMINATION AND EXCESSIVE FUZZING OR FRAYING OF THE CUT EDGES. THIS NECESSITATES THE USE OF TIME CONSUMING AND REPETITIVE TECHNIQUES TO ACHIEVE ACCEPTABLE MACHINED SURFACES.

SOLUTION - EXPERIENCE INDICATES THAT RECENTLY DEVELOPED ADVANCED CUTTING TECHNIQUES, INCLUDING HIGH PRESSURE WATER JET, LASERS, AND CONVENTIONAL DIAMOND TOOLS HAVE THE ABILITY TO EFFECTIVELY MACHINE KEVLAR WITH INCREASED TOOL LIFE.

(7244) TITLE - LASER CUTTING AND WELDING OF METAL

330

PROBLEM - TECHNIQUES ARE NEEDED THAT WILL REDUCE CUTTING AND WELDING TIMES ON AIRCRAFT PARTS.

SOLUTION - DEVELOP LASER WELDING TO PERMIT RAPID, PRECISE AND STRUCTURALLY SOUND WELDS. DEVELOP LASER CUTTING METHODS TO CUT COMPLEX CORNERS AT HIGH SPEED.

(7353) TITLE - SUPERPLASTIC FORMING OF ALUMINUM ALLOY HELICOPTER COMPONENTS

150

200

PROBLEM - HIGH STRENGTH ALUMINUM HELICOPTER COMPONENTS USE CONVENTIONAL FORMING OPERATIONS SUCH AS EXTRUSION OR FORGING. THESE PROCEDURES GENERALLY REQUIRE A LARGE NUMBER OF OPERATIONS AND THEREFORE ARE COSTLY AND TIME CONSUMING.

SOLUTION - SUPERPLASTIC FORMING OF ALUMINUM ALLOYS OFFERS AN ALTERNATIVE TO THE LIMITATIONS OF CONVENTIONAL FORMING OPERATIONS, AND WILL PROVIDE SIGNIFICANT COST AND WEIGHT SAVINGS.

(7396) TITLE - INTEGRAL LOW COST FASTENING SYSTEMS FOR RPV'S

175

150

PROBLEM - JOINING OF COMPONENTS IN RPV SYSTEMS IS ACCOMPLISHED BY THE TRADITIONAL SCREW, NUT, AND BOLT METHODS. UTILIZATION OF THESE METHODS ADD HIGH FABRICATION AND ASSEMBLY COST AND WEIGHT TO THE SYSTEM.

SOLUTION - THIS PROJECT WILL DEVELOP THE TECHNOLOGY FOR UTILIZATION AND INTEGRATION OF PLASTIC FASTENERS, SNAP LATCHES, AND OTHER LOW COST MANUFACTURE AND ASSEMBLY TECHNIQUES INTO THE PRODUCTION OF RPV SYSTEMS.

COMPONENT -- SECONDARY STRUCTURES

(7183) TITLE - SEMI-AUTO COMPOSITE MFG SYS FOR FUSELAGE SEC STRUCT

345 155 300

PROBLEM - HELICOPTER FUSELAGE STRUCTURES HAVE HIGH MANUFACTURING COST DUE TO HIGH PART COUNT AND HIGH ASSEMBLY COSTS. METHODS OF COMPOSITE FABRICATION HAVE BEEN INVESTIGATED BUT HAND OPERATIONS RESULT IN HIGH LABOR COSTS.

SOLUTION - USE EQUIPMENT AND TECHNIQUES DEVELOPED BY INDUSTRY IN SUPPORT OF AIR FORCE COMPOSITE COMPONENT PROGRAMS. THE SELECTED SYSTEM WILL BE UPDATED AND MODIFIED TO ACCOMODATE HELICOPTOR COMPONENTS WHICH ARE MORE COMPLEX AND HAVE MORE CURVATURE THAN AF COMP.

(7202) TITLE - THERMOPLASTICS FOR HELICOPTOR SECONDARY STRUCTURES

225 225 100

PROBLEM - FORMING FIBER REINFORCED THERMOPLASTIC COMPONENTS INTO COMPLEX, MULTI-CURVED STRUCTURAL CONFIGURATIONS, WITH UNIFORM FIBER DISTRIBUTION, MINIMUM WARPAGE, AND ACCEPTABLE DIMENSIONAL TOLERANCES HAS NOT BEEN ESTABLISHED FOR AIRCRAFT COMPONENTS.

SOLUTION - EFFORT WILL ESTABLISH TECHNIQUES, SPECIAL TOOLING, AND PROCESSES TO FORM SUCH COMPONENTS WITH VACUUM OR AIR PRESSURE ASSIST METHODS. IN ADDITION, TECHNIQUES TO RESTRAIN THE MATRIX AND FIBER LAYERS IN POSITION DURING HEAT-UP CYCLE WILL BE ESTABLISHED.

(7344) TITLE - RIM MOLDING OF LOW COST SECONDARY STRUCTURES

160 160

PROBLEM - PRESENT METHODS OF FABRICATING AIRCRAFT SECONDARY STRUCTURES (ESPECIALLY ACCESS DOORS) INVOLVE EXCESSIVE LABOR AND EXPENSIVE MATERIALS. STRUCTURES MADE FROM FIBER REINFORCED SANDWICH PANELS AND/OR FORMED SHEET METAL OFTEN REQUIRE COMPLEX ASSEMBLY.

SOLUTION - ESTABLISH A PROCESS TO PRODUCE THESE SECONDARY STRUCTURES FROM REACTION INJECTED MOLDED (RIM) URETHANES. RIM IS A LOW PRESSURE HOLDING TECHNIQUE WHICH CAN USE LOW COST COMPOSITE MOLDS TO GIVE EXTREMELY COST EFFECTIVE STRUCTURES.

(7385) TITLE - COMPOSITE ENGINE INLET

350

PROBLEM - MOLDING COMPOSITES TO SHAPES SUCH AS THAT OF THE BLACK HAWK INLET IN PRODUCTION HAS NOT BEEN DEMONSTRATED.

SOLUTION - ESTABLISH A PRODUCT--- MOLDING PROCESS FOR MANUFACTURING AN INLET COMPOSED OF ALUMINIZED GLASS FIBERS IN A POLYAMINE MATRIX.

(7390) TITLE - FIBER REINFORCED THERMOPLASTIC STRUCTURE

350

PROBLEM - A METHOD OF INCORPORATING HIGH MODULUS FIBER REINFORCED THERMOPLASTIC IN AIRFRAME STRUCTURES HAS NOT BEEN ESTABLISHED.

SOLUTION - ESTABLISH A MANUFACTURING METHOD TO INCORPORATE HIGH STRENGTH AND HIGH MODULUS FIBERS INTO THERMOPLASTIC FOR HELICOPTER STRUCTURES.

COMPONENT -- STRUCTURAL MEMBERS

(7193) TITLE - ADV FILAMENT WNDG FOR AIRCRAFT COMPONENTS

350

PROBLEM - CURRENT COMMERCIAL PRACTICES ON FILAMENT WINDING ARE EXPENSIVE.

SOLUTION - A NUMBER OF RECENT DEVELOPMENT IN FILAMENT WINDING G TECHNOLOGY ORIGINATING IN THE U.S., DENMARK, AND HUNGARY SHOW PROMISE OF EXPANDING THE FLEXIBILITY OF THE FILAMENT WINDING PROCESS.

(7342) TITLE - PULTRUSION OF HONEYCOMB SANDWICH STRUCTURES

105 200

PROBLEM - FABRICATION OF HONEYCOMB SANDWICH PANELS IS LABOR INTENSIVE AND FACE-TO-CORE BONDING OFTEN TAKES TWO CURE OPERATIONS. PULTRUSION CAN BE USED FOR CONTINUOUS PRODUCTION BUT COMMERCIAL PARAMETERS AND TOOLING ARE NOT SUITABLE FOR MILITARY USE.

SOLUTION - ESTABLISH TECHNOLOGY NECESSARY FOR PRODUCTION PULTRUSION OF SANDWICH STRUCTURES, INCLUDING BEAMS, FOR USE IN COMPOSITE AIRFRAMES. PARAMETERS WILL BE GENERATED AND OPTIMIZED FOR PULTRUDING MILITARY QUALITY FLOORING.

(7373) TITLE - SAND PUNCH SPF OF TITANIUM

300

PROBLEM - MANY AIRFRAME PARTS CONSIST OF MULTIPLE DETAILS RIVETED OR SPOT-WELDED TOGETHER THAT INCREASE THE FORMING CYCLE, TOOLING COSTS, AND LABOR. ALSO MANY PART CONTOURS ARE IMPOSSIBLE TO FORM BY CONVENTIONAL METHODS.

SOLUTION - THIS PROJECT WILL DEVELOP A "SAND PUNCH" METHOD OF SUPERPLASTICALLY FORMING TITANIUM ALLOYS AS A PRACTICAL, ECONOMICAL PRODUCTION METHOD.

(7374) TITLE - BI-MATRIX CARBON-CARBON STRUCTURAL COMPONENTS

450

PROBLEM - RECENT ADVANCES IN THE DEVELOPMENT OF LASER WEAPONS HAVE REAPPRAISED THE TIMING FOR THE INTRODUCTION OF LASER TACTICAL WEAPONS.

SOLUTION - THIS PROJECT WILL DEVELOP THE MANUFACTURING TECHNOLOGY NECESSARY FOR PRODUCTION AND RETROFIT OF BI-MATRIX CARBON-CARBON STRUCTURAL COMPONENTS. BI-MATRIX C-C IS A HIGH STRENGTH LIGHTWEIGHT INTEGRAL HIGH ENERGY LASER PROTECTIVE BARRIER SYSTEM.

(7389) TITLE - SUPERPLASTIC FORMING OF ALUMINIUM COMPONENTS

300 400

PROBLEM - CURRENT METHODS OF MACHINING ALUMINIUM FORGINGS ARE EXPENSIVE AND REQUIRE AN EXCESSIVE NUMBER OF PARTS.

SOLUTION - ESTABLISH FABRICATION TECHNOLOGY NECESSARY TO MANUFACTURE ALUMINIUM AIRFRAME COMPONENTS THRU THE APPLICATION OF SUPERPLASTIC FORMING. THIS WILL REDUCE COSTS AND PARTS COUNTS.

COMPONENT -- STRUCTURAL PANELS

(7359) TITLE - POLYIMIDE FOAM FOR MULTIFUNCTIONAL AIRCRAFT STRUCT 175 175

PROBLEM - NOMEX/POLYIMIDE FOAM HAS BEEN DEVELOPED AS A STRUCTURAL CORE FOR MULTIFUNCTIONAL AIRCRAFT SANDWICH STRUCTURES. CHOPPED GLASS AND GRAPHITE ARE INCORPORATED INTO THE FOAM TO GIVE REQUIRED CHARACTERISTICS. PRODUCTION IS HIGH COST WITH LARGE VARIATIONS.

SOLUTION - AN AUTOMATED FOAM DISPENSING UNIT WILL BE COMBINED WITH HONEYCOMB FORMING AND SHAPING EQUIPMENT TO FORM CURVED OR COMPLEX SHAPED HONEYCOMB CORE WITH CURED POLYIMIDE FOAM IN PLACE. MICROWAVE, RF, OR FORCED AIR WILL BE USED FOR CURING.

(7395) TITLE - HAND HELD WATER JET CUTTING 150 100

PROBLEM - CONVENTIONAL METHODS OF CUTTING FLAT AND FORMED COMPOSITE AND NONMETALLIC PANELS RESULTS IN RAPID TOOL WEAR AND HIGH DUST LEVELS. WHEN USED ON KEVLAR FUZZING OF EDGES OCCURS RESULTING IN SECONDARY OPERATIONS.

SOLUTION - THIS PROJECT WILL DEVELOP A HAND HELD WATER JET CUTTER TO BE USED FOR CUTTING COMPOSITES.

\*\*\*\*\*  
\* C A T E G O R Y \*  
\*-----\*  
\*AVIONICS \*  
\*\*\*\*\*

COMPONENT -- DISPLAYS

(7319) TITLE - MULTI-LEGEND DISPLAY SWITCH (MLD/S) 310 290

PROBLEM - EXPERIMENTAL VERSIONS ARE EXPENSIVE AND DIFFICULT TO MANUFACTURE BECAUSE THE MOUNTING OF THE COMMERCIALLY AVAILABLE ELECTRONICS DISPLAY CHIPS AND SWITCHES MUST BE DONE BY HAND TO OBTAIN PROPER RUGGEDNESS AND OPERATION OF THE STRUCTURE.

SOLUTION - MAKE THE MLD/S A MANUFACTURABLE ITEM SO THAT IT CAN BE MADE ROUTINELY AVAILABLE FOR INCORPORATION IN AVIONIC SYSTEMS. ESTABLISH THE MANUFACTURING TECHNIQUES TO PROPERLY MOUNT, ALIGN, AND FABRICATE MILITARIZED DISPLAYS AND SWITCHES.

FUNDING (\$000)

PRIOR 80 81 82 83 84

COMPONENT -- GENERAL

(7292) TITLE - MMT-FAULT DETECTION / ISOLATION TESTING OF MICROPR 53 150 250

PROBLEM - TESTING OF CPU CARDS INTERMITTENT MICROPROCESSOR PART FAILURES ARE MOST DIFFICULT PROBLEMS TO SOLVE. STD AUTOMATIC TEST EQPT BECOMES INEFFICIENT, OR UNPREGNABLE, WHEN CMPLX INTEGRATED CKTS ARE PORTIONS OF THE PRINTED CKT CARD TESTED.

SOLUTION - DEVELOP METHODS OF ISOLATING LARGE NUMBER OF LEADS ON SAME BUSS FOR TEST PURPOSES, USE PLUGGABLE CPU (REPLACING IT WITH A SIMULATOR WHENEVER THE PCB FAILS), AND DEVELOP PROGRAMMING TECHNIQUES.

(7293) TITLE - MOLDED WAVEGUIDE PARTS FOR ANTENNAS 265

PROBLEM - PHASED ARRAY ANTENNAS ARE TYPICALLY VERY EXPENSIVE AND HEAVY. THEREFORE, MECHANICALLY SCANNED ANTENNAS HAVE BEEN PREFERRED FOR ARMY AIRBORNE APPLICATIONS. THE ARRAY ANTENNA WAVEGUIDE IS A PRIME CONTRIBUTOR TO WEIGHT AND COST.

SOLUTION - BY USING INJECTION MOLDING AND METALIZATION OF THE COMPOSITE FORM LESS EXPENSIVE AND LIGHTER WEIGHT WAVEGUIDES CAN BE FABRICATED.

COMPONENT -- GUIDANCE SYSTEMS

(7383) TITLE - USE OF MOLDED PLASTIC HARDWARE IN TWO AXIS DRY GYROSCOPES 250

PROBLEM - THE PRIMARY COST DRIVER IN THE MANUFACTURE OF CURRENT INERTIAL GYROSCOPES IS THE MACHINING OF SMALL PRECISION COMPLEX METAL PARTS. THE MACHINED PARTS ARE HIGH COST AND ALSO REPRESENT PRODUCTION LEAD TIME PROBLEMS.

SOLUTION - MOLD THE GYROSCOPES FROM CARBON FIBER COMPOSITES.

\*\*\*\*\*  
\* C A T E G O R Y \*  
\*-----\*  
\*DRIVE SYSTEM \*  
\*\*\*\*\*

COMPONENT -- BEARINGS

(7334) TITLE - ESTABLISH MANTECH FOR POWDER PROC ROLLING BEARINGS 190 140

PROBLEM - LIFE IMPROVEMENTS CONDUCTED ON POWDER PROCESSED AISI M50 STEEL HAVE BEEN OBSERVED WHEN COMPARED TO WROUGHT CONSUMABLE VACUUM ARC REMELTED (CVN) AISI M50 STEEL.

SOLUTION - DEVELOP ECONOMICALLY SOUND PRODUCTION PROCEDURES FOR QUALITY ASSURANCE OF THE POWDER, PRESSING AND SINTERING, AND SUBSEQUENT OPERATIONS TO MANUFACTURE FINISHED COMPONENTS. THE COMPONENTS WILL BE PRESSED TO NEAR NET SHAPE.

FUNDING (\$000)

PRIOR 80 81 82 83 84  
-----

COMPONENT -- BEARINGS

(CONTINUED)

(7391) TITLE - BEARING DIAGNOSTIC AND RECLAMATION TECHNIQUES

100 150

PROBLEM - CURRENT HELICOPTER OVERHAUL PROCEDURES REQUIRE BEARING REPLACEMENT RATHER THAN REPAIR/OVERHAUL. WITH PROPER DIAGNOSTIC AND RECLAMATION PROCEDURES, APPROX 35 PERCENT OF THE DEFECTIVE BEARINGS COULD BE RESTORED.

SOLUTION - THIS PROJECT WILL DEVELOP THE TECHNOLOGY FOR IDENTIFYING DEFECTIVE BEARINGS AND THE REPAIR/RESTORATION OF REJECTED BEARINGS. THE INTEGRATED DIAGNOSTIC AND RECLAMATION TECH IS AN ADVANCED TECH THAT IS USED BY PRIVATE INDUSTRY.

COMPONENT -- GEARS

(7155) TITLE - COST EFFECTIVE MFG METHODS FOR HELICOPTER GEARS

410 180 320

PROBLEM - DEMAND IN HELICOPTER OPERATION OF GREATER RELIABILITY OF HIGH PERFORMANCE GEARS AT LOWER COST HAS REQUIRED THAT IMPROVED PROCESSING AND EVALUATION TECHNIQUES BE INSTITUTED.

SOLUTION - PROJECT WILL ADDRESS THE TOTAL GEAR MANUFACTURING PROCESS, INTEGRATING AVAILABLE NON-DESTRUCTIVE INSPECTION PROCEDURES AND REPLACING INDIVIDUAL TOOTH GRINDING WITH A COMBINATION OF AUSROLLING AND A FINAL ROTARY TOOTH FINISHING PROCEDURE.

(7187) TITLE - POWDER MET GEARS FOR GAS TURBINE ENGINES

220 275

PROBLEM - PRODUCE GEARS FOR TURBINE ENGINES AT A LOWER COST.

SOLUTION - DEVELOP THE MANUFACTURING AND QUALIFICATION FOR THE PRODUCTION OF LIGHTLY STRESSED, LOW TEMPERATURE POWDER METALLURGY GEARS FOR SELECTED NON-CRITICAL APPLICATIONS.

(7189) TITLE - POWDER METALLURGY GEARS FOR GAS TURBINE COMPONENTS

200 250

PROBLEM - NEW HIGH TEMPERATURE GEAR MATERIALS NOW PLANNED FOR SERVICE IN HELICOPTOR DRIVE TRAINS ARE BECOMING INCREASINGLY DIFFICULT TO PROCESS DUE TO THEIR HIGHER ALLOY CONTENT. AS THE DIFFICULTY INCREASES, SO DOES THE COST.

SOLUTION - POWDER METAL NEAR NET SHAPE PROCESSING COUPLED WITH ADVANCED SURFACE PROCESSING REPRESENTS THE BEST APPROACH FOR THESE MATERIALS. THIS PROJECT WILL ESTABLISH A FULL MANUFACTURING AND QUALITY ASSURANCE SEQUENCE.

(7199) TITLE - MH+T-SURFACE HARD OF GEARS BY LASERS

380 250

PROBLEM - CASE CARBURIZING IS EXPENSIVE, REQUIRING MUCH ENERGY, QUENCHING DIES, AND FINAL GRINDING.

SOLUTION - THIS NEW METHOD WILL REDUCE COSTS BY REDUCING THE ENERGY REQUIRED TO HEAT TREAT, ELIMINATE THE QUENCHING PROCESS, AND PROVIDE THE POTENTIAL FOR ELIMINATING FINAL GRIND.

COMPONENT -- GEARS

(CONTINUED)

(7267) TITLE - LOW COST GEARS FOR TURBINE ENGINES AND ACC GEARBOX 415 160

PROBLEM - CURRENT PRODUCTION METHODS FOR AIRCRAFT GEARS DO NOT TAKE FULL ADVANTAGE OF THE ADVANCED TECHNOLOGICAL PROCESSES AVAILABLE.

SOLUTION - DEMONSTRATE THE ECONOMY OF USING ADVANCED TECHNOLOGICAL PROCESSES SUCH AS ORBITAL PRECISION FORGING, LASER OR ELECTRON BEAM HARDENING, ROLL-FORMED GEAR TEETH AND POT BROACHING IN THE MANUFACTURE OF AIRCRAFT GEARS.

(7298) TITLE - MMT-EVALUATION OF HIGH TEMPERATURE CARBURIZING 25 150 250

PROBLEM - GEAR CARBURIZING IS PRESENTLY CARRIED OUT WITH A RELATIVELY SLOW ENDOTHERMIC PROCESS, TYPICALLY AT 1700 DEG F, WHICH REQUIRES SURFACE PROTECTION AGAINST DECARBURIZING DURING THE CYCLE OR A POST HEAT TREAT REMOVAL OF THE DECARBURIZED LAYER.

SOLUTION - REDUCE PROCESSING TIME BY INCREASING THE OPERATING CAPACITY. ALSO INVESTIGATE VACUUM CARBURIZING AND HARDING OF VARIOUS GEAR CONFIGURATIONS IN ORDER TO PRODUCE A MORE UNIFORM CARBON PROFILE OF GEAR TEETH.

(7325) TITLE - AUTO LASER INSPECTION OF SPIRAL BEVEL GEARS 160 250

PROBLEM - THE CONTROL OF TOOTH GEOMETRY IN SPIRAL BEVEL GEARS REQUIRES EXTENSIVE MANUAL INSPECTION AND CHECKS RELATIVE TO MASTER GEARS. THE ACCEPTANCE / REJECTION CRITERIA ARE HIGHLY SUBJECTIVE AND IMPACT THE PRODUCT'S USEFUL LIFE.

SOLUTION - APPLY LASER MEASUREMENT TO THE SURFACE OF SPIRAL BEVEL GEARS. THIS WILL AUTOMATE THE INSPECTION TECHNIQUES AND PROVIDE BETTER QUALITY CONTROL WITH REDUCTION IN INSPECTION TIME.

(7367) TITLE - BEARING GRINDING AND HONING TECHNIQUES 975

PROBLEM - CURRENT HELICOPTER OVERHAUL PROCEDURES CALL FOR BEARINGS TO BE REPLACED INSTEAD OF BEING OVERHAULED OR REPAIRED.

SOLUTION - THIS PROJECT WILL DEVELOP THE MFG TECHNOLOGY FOR REPAIR / RESTORATION OF REJECTED BEARING SURFACES.

(7376) TITLE - AUTO INSPECT AND PRECISION GRINDING OF SB GEARS 215 499

PROBLEM - CURRENT MFG METHOD FOR SPIRAL BEVEL GEARS IS LABOR INTENSIVE, REQUIRING CONTACT PATTERN CHECKS WITH EXPENSIVE MASTER MATING GEARS. THIS PATTERN SHIFTS WITH A CHANGE IN TORQUE AND TEMPERATURE. AS A RESULT THE CURRENT TOOTH FORM EXPERIENCES GREAT STRES

SOLUTION - DEVELOP AN AUTOMATED PROD PROCESS OF GRINDING SPIRAL BEVEL GEARS BY TAPE CONTROLLED MACHINES, BASED ON A COORDINATE SYS MADE POSSIBLE BY A PARTIAL NON-INVOLUTE TOOTH FORM.

PRIOR 80 81 82 83 84  
-----

COMPONENT -- GEARS

(CONTINUED)

(7394) TITLE - DOUBLE HELICAL GEAR

330 375

PROBLEM - THE LIFE LIMITING FAILURE MODE OF AIRCRAFT GEARS IS GEAR TOOTH  
PITTING OR SPALLING. THE DOUBLE HELICAL GEAR PLANETARY SYSTEM WILL UPGRADE  
PERFORMANCE OF THE TRANSMISSION.

SOLUTION - THIS PROJECT WILL ESTABLISH THE MANUFACTURING PROCESS TO PRODUCE  
THE ONE-PIECE DOUBLE-HELICAL GEAR PLANETARIES BY SHAPING, SHAVING,  
HARDENING, AND HONING TO REDUCE TRANSMISSION FAILURE RATES.

(7398) TITLE - COMPUTER CONTROLLED GEAR CROWNING

200

PROBLEM - PRESENT TECHNOLOGY OF GRINDING CROWNED SPUR GEARS IS BASED ON  
COMPUTER AIDED USAGE. A PRECISION MICROPROCESSOR CONTROLLED STEPPER MOTOR  
SYSTEM TO CORRELATE THE MOVEMENT OF WHEEL AND WORK TABLE IS NEEDED FOR  
INCREASED ACCURACY

SOLUTION - DEVELOP A MICROPROCESSOR CONTROLLED STEPPER MOTOR SYSTEM TO PERFECT  
THE GEAR CROWNING TECHNOLOGY.

(7405) TITLE - PLASMA NITRIDING OF HELICOPTER GEARS

350 250

PROBLEM - CONVENTIONAL AMMONIA GAS NITRIDING MUST BE PRECEDED BY EXTENSIVE  
CHEMICAL AND ABRASIVE CLEANING BEFORE EXPOSURE TO THE NITRIDING ATMOSPHERE  
BECAUSE THE CUTTING TOOL BURNISHED METAL SURFACES RESIST THE PENETRATION OF  
THE CASE HARDENING NITROGEN.

SOLUTION - DEVELOP A PLASMA NITRIDING PROCESS. THE PLASMA IDEALLY BLAST CLEANS  
THE SURFACE AND PROMPTLY SATURATES THE SURFACE WITH NITROGEN. THE NITROGEN  
THEN DIFFUSES INTO THE SURFACE.

COMPONENT -- GENERAL

(7324) TITLE - FREEWHEEL SPRING CLUTCH MANUFACTURING PROCESS

250

PROBLEM - WITH THE HIGH OUTPUT SPEED OF TODAY'S ENGINES, THE NEED EXISTS FOR  
A COST EFFECTIVE FABRICATION PROCESS OF HIGH SPEED OVERRUNNING CLUTCHES TO  
BE USED IN HELICOPTER TRANSMISSIONS.

SOLUTION - DEVELOP A PROCESS TO PRODUCE HELICAL SPRINGS WITHOUT THE NEED OF  
"START-STOP" HOLES WHICH CREATE AN IMBALANCE AND STRESS CONCENTRATION  
UTILIZING METAL MACHINING PROCESSES.

MMT FIVE YEAR PLAN  
RCS DRCMT 126

FUNDING (\$000)

PRIOR 80 81 82 83 84

COMPONENT -- SHAFTS

(7108) TITLE - MFG TECHNIQUES FOR TRANSMISSION SHAFT SEALS

135 100

PROBLEM - CURRENT HELICOPTER TRANSMISSION SEALS ARE SUSCEPTABLE TO WEAR AND THERMAL DEGRADATION RESULTING IN LEAKAGE OF TRANSMISSION OIL AND FREQUENT SEAL REPLACEMENT.

SOLUTION - INTEGRAL MOLDING OF A HYBRID ELASTOMERIC SEGMENTED CARBON RING SEAL COMBINES THE COMPLIANCE OF ELASTOMERIC TIP SEALS WITH THE WEAR RESISTANCE AND TEMPERATURE TOLERANCE OF MECHANICAL CARBON SEALS.

(7326) TITLE - ADAPT OF ELECTRON BEAM WELDING FOR REPAIR SHAFTS

200 350

PROBLEM - DURING OVERHAUL OF HELICOPTER TRANSMISSIONS THE PERCENTAGE OF PART REJECTION FOR SPLINE WEAR IS HIGH FOR GEARS WITH SPLINE INTEGRAL SHAFTS.

SOLUTION - ESTABLISH THE TOOLING AND INSPECTION PROCEDURES FOR ELECTRON BEAM (EB) WELDING OF COMPLEX GEAR SHAFT/SPLINE ELEMENTS. BY THIS METHOD THE MOST EXPENSIVE ELEMENT (THE GEAR) CAN BE SAVED BY A SINGLE LOW COST WELD OF A NEW SPLINE TO THE GEAR/SHAFT.

COMPONENT -- TRANSMISSION HOUSING

(7354) TITLE - INTEGRALLY STIFFENED HELICOPTER TRANS CASE

650 650 600

PROBLEM - THE LOW STIFFNESS OF THE CURRENT CH-47 CAST MAGNESIUM ALLOY TRANSMISSION CASE CAUSES EXCESSIVE GEAR WEAR, EXCESSIVE NOISE AND EXCESSIVE VIBRATION.

SOLUTION - THIS PROJECT WILL ESTABLISH THE MANUFACTURING PROCESS FOR CASTING FIBER REINFORCED, INTEGRALLY STIFFENED CH-47 TRANSMISSION CASES.

(7378) TITLE - STAINLESS STEEL FABRICATED HOUSING

600

PROBLEM - HELICOPTER TRANSMISSION HOUSINGS ARE MADE FROM MAGNESIUM CASTINGS. THEY ARE COSTLY AND HAVE HIGH REPLACEMENT RATES AT OVERHAUL DUE TO CRACKS AND CORROSION.

SOLUTION - APPLY VARIOUS FABRICATION TECHNIQUES TO VARIOUS MATERIALS SUCH AS STAINLESS STEEL TO PRODUCE A LIGHTER WEIGHT, NON-CORROSIVE, AND LESS COSTLY HOUSING.

\*\*\*\*\*  
\* C A T E G O R Y \*  
\*\*\*\*\*  
\*GENERAL\*  
\*\*\*\*\*

COMPONENT -- ALL

(7343) TITLE - CONTROLLED LEAK PRESSURE PROCESS

200

PROBLEM - LIGHTWEIGHT COMPOSITE STRUCTURES ARE TYPICALLY COMPOSED OF A NOMEX CORE WITH BONDED FIBER REINFORCED SKINS. THE CORE MATERIAL AND ASSOCIATED MACHINING IS COSTLY AND SHOULD BE ELIMINATED.

SOLUTION - THE CONTROLLED LEAK PRESSURE PROCESS PROVIDES A MEANS OF PRODUCING "HOLLOW" STRUCTURES WITHOUT THE USE OF A PRESSURE BAG OR CORE MATERIAL. THE ULTIMATE RESULT IS A LIGHTWEIGHT, HOLLOW CORE, INTEGRALLY STIFFENED STRUCTURE.

(7362) TITLE - ENG DESIGN HANDBOOK FOR TITANIUM CASTINGS

55 70

PROBLEM - NO PROVISION HAS BEEN MADE FOR COLLECTING INFORMATION FROM THE ADVANCING STATE OF THE ART IN CAST TITANIUM ALLOYS.

SOLUTION - THIS PROJECT WOULD COLLECT INFORMATION FROM PAST AND ONGOING PROJECTS DEALING WITH HIGH QUALITY TITANIUM CASTINGS, CREATE NEW DATA TO FILL TECHNICAL GAPS, AS REQUIRED, AND GENERATE AN ENGINEERING DESIGN HANDBOOK.

COMPONENT -- SAFETY

(7022) TITLE - PDM OF POLYPHOSPHAZENE FIRE RESIST HYDRAULIC FLUIDS

220

PROBLEM - CURRENT HYDRAULIC FLUIDS THAT MEET REQUIRED PERFORMANCE SPECIFICATIONS ARE FLAMMABLE.

SOLUTION - THE DEVELOPMENT OF PHOSPHAZENE FLUIDS DEMONSTRATE THERMAL STABILITY, VISCO-ELASTIC PROPERTIES, AND FIRE RESISTANCE. THIS WOULD INCREASE THE FIRE SAFETY OF ARMY AIRCRAFT.

\*\*\*\*\*  
\* C A T E G O R Y \*  
\*-----\*  
\* ROTOR SYSTEM \*  
\*\*\*\*\*

COMPONENT -- BLADE

(7052) TITLE - ULTRASONICALLY ASSISTED NOSE CAP FORMING

718 60

PROBLEM - NOSE CAPS USED ON LEADING EDGE OF ROTOR BLADES ARE CURRENTLY BEING HOT FORMED, A TECHNIQUE WHICH REQUIRES LONG PROCESSING TIMES, COSTLY TOOLING, AND EXPENSIVE CHEMICAL ETCHING.

SOLUTION - DEVELOP AN ULTRASONICALLY ASSISTED COLD FORMING PROCESS TO FABRICATE LEADING EDGE EROSION STRIPS FROM SHEET MATERIAL.

PRIOR 80 81 82 83 84  
-----

COMPONENT -- BLADE

(CONTINUED)

(7288) TITLE - DET OF OPTIMAL CURE COND FOR PROC FIBER REIN COMPO

125 100 175

PROBLEM - CURRENT METHODS OF CURING COMPOSITES ARE BASED ON EMPIRICAL DETERMINATION OF REQUIRED PROCESSING CONDITIONS. A TRIAL AND ERROR PROCEDURE IS FOLLOWED UNTIL THE MANUFACTURER IS REASONABLY SATISFIED WITH MECHANICAL PROPERTIES.

SOLUTION - BY DEVELOPING AND EMPLOYING IMPROVED METHODS OF DETERMINING REQUIRED PROCESSING CONDITIONS FOR COMPOSITES, TIME AND PRODUCTIVITY CAN BE IMPROVED IN THE MOLD.

(7339) TITLE - COMPOSITE TAIL ROTOR BLADE

452 1355 780

PROBLEM - FILAMENT WINDING FROM A SOLID FLEXBEAM TO AN OPEN SPAR SECTION, WINDING TO NET SHAPE, IMPROVED RESIN CONTROL AND TOLERANCE CONTROL MUST BE OBTAINED TO ENHANCE THE COST EFFECTIVENESS OF FLEXBEAM TAIL ROTERS.

SOLUTION - TECHNIQUES WILL BE DEVELOPED FOR CONTINUOUS FILAMENT WINDING FROM OPEN TO CLOSED SECTIONS, WINDING NET CONTOUR SHAPE, OPTIMIZING TOLERANCE CONTROL WITH IMPROVED TOOLING, AND IMPROVED RESIN CONTROL TO ENSURE MINIMUM WEIGHT COMPONENTS.

(7340) TITLE - MM+T-COMPOSITE MAIN ROTOR BLADE

878 2092 250

PROBLEM - CURRENT PRODUCTION COMPOSITE BLADE PROGRAMS HAVE NOT BEEN ORIENTED TOWARD OPTIMIZING MANUFACTURING TECHNIQUES/PROCESSES RELATED TO BLADE CONFIGURATIONS, FABRICATION METHODS, AND IMPROVED STRUCTURAL RELIABILITY.

SOLUTION - IMPROVED METHODS WILL INCLUDE SOFT INFLATABLE MANDRELS, INCREASE IN FIBER BAND WIDTH, IMPROVED MATRIX CONTROL PROCEDURES, BALANCED SHELL TOOLING, AND NET SHAPE WINDING.

(7403) TITLE - ELECTRONIC BLADE BALANCE SYSTEM

275 250

PROBLEM - THE STATIC BALANCING OF ROTOR BLADES USING CURRENT METHODS RESULTS IN A SIGNIFICANT DIRECT LABOR AND ELAPSED TIME EXPENDITURE.

SOLUTION - DEVELOP A COMPUTER ASSISTED BLADE BALANCE MACHINE WHICH DETERMINES THE AMOUNT AND LOCATION OF CORRECTIVE BALANCE WEIGHT ADDITIONS.

COMPONENT -- BLADE/COMPOSITE STRUCTURES

(7382) TITLE - LOW COST COMPOSITE MAIN ROTOR BLADE FOR THE UH-60A

100 3200

PROBLEM - MANUFACTURING TECHNOLOGY FOR COCURING GLASS AND GRAPHITE FILAMENT WOUND MAIN ROTOR BLADES HAS NOT BEEN ESTABLISHED FOR THE PRODUCTION ENVIRONMENT.

SOLUTION - ESTABLISH THE MANUFACTURING TECHNIQUES FOR WET FILAMENT WINDING AND COCURING GRAPHITE AND GLASS ALL-COMPOSITE MAIN ROTOR BLADES.

COMPONENT -- BLADE/LEADING EDGE

(7175) TITLE - AUTO BLADE CONTOUR INSP COM AIDED INSPECTION

275

PROBLEM - MEASUREMENT OF THE CONTOUR OF CERTAIN HELICOPTOR SURFACES ARE REQUIRED TO BE MADE WITH A HIGH DEGREE OF ACCURACY ON SURFACES WITH WIDTHS UP TO 42 INCHES AND AT A LARGE NUMBER OF POINTS. AVAILABLE SYSTEMS ARE SUSCEPTIBLE TO ERRORS.

SOLUTION - PROVIDE A COMPUTER AIDED, NONCONTACTING OPTICAL GAUGING SYSTEM TO AUTOMATICALLY INSPECT CONTOURS OF SPARS AND AIRFOILS OF HELICOPTOR ROTOR BLADES. THIS METHOD WILL INCREASE ACCURACY, REDUCE TIME REQUIRED BY 1/3 AND PROVIDE REPRODUCIBLE INSPECTION.

COMPONENT -- BLADE/SPAR

(7360) TITLE - EXTRUSION OF PRECISION HOLLOW AIRCRAFT COMPONENTS

250 200

PROBLEM - SOME HOLLOW COMPONENTS, SUCH AS TITANIUM BLADE SPARS, ARE MANUFACTURED FROM SHEET BY WELDING A TUBE AND HOT FORMING. THIS IS A VERY EXPENSIVE TECHNIQUE COSTS.

SOLUTION - CAD/CAM TECHNIQUES, RECENTLY DEVELOPED FOR EXTRUSION OF SOLID SHAPES, CAN BE APPLIED TO HOLLOW TO IMPROVE EXTRUSION TOLERANCES AND REDUCE MANUFACTURE

COMPONENT -- HUB

(7241) TITLE - MHT-HOT ISOSTATICALLY PRESSED TITANIUM CASTINGS

595 100 500

PROBLEM - THE CURRENT METHOD OF MANUFACTURING ROTOR HUBS RESULTS IN EXCESSIVE USE OF MATERIALS AND MACHINING. PROJECT FOR FABRICATION OF A COMPOSITE MAIN ROTOR HUB HAS BEEN CANCELLED. THE CURRENT FORGED HUB IS A LONG-LEAD TIME ITEM.

SOLUTION - ESTABLISH THE MANUFACTURING PROCESS FOR HOT ISOSTATIC PRESSING (HIP) OF A CAST BLACKHAWK TITANIUM ROTOR HUB. THE REQUIRED MATERIAL PROPERTIES ARE ATTAINABLE AND ACOST SAVINGS OF 36 PERCENT IS EXPECTED.

(8139) TITLE - COMPOSITE MAIN ROTOR HUB

500

PROBLEM - UNACCEPTABLE SIZE AND WEIGHT PENALTIES ARE INCURRED WHEN CONVENTIONAL METALLIC MATERIALS ARE USED FOR ADVANCED HUB DESIGNS.

SOLUTION - DEVELOP THE FABRICATION TECHNOLOGY, TOOLING AND AUTOMATED TECHNIQUES NECESSARY TO MANUFACTURE COMPOSITE ROTOR HUBS.

FUNDING (\$000)

PRIOR 80 81 82 83 84

COMPONENT -- MISC COMPONENTS

(7119) TITLE - MMT-NON-DESTRUCTIVE EVAL TECH FOR COMPOSITE STRUCT 976 260 200

PROBLEM - IMPLEMENTATION OF COMPOSITE STRUCTURES IN THE ARMY AIRCRAFT IS  
DEPENDANT UPON THE ABILITY TO DETECT AND EVALUATE DEFECTS.

SOLUTION - ESTABLISH A VIABLE AND COMPREHENSIVE IN-PROCESS INSPECTION PROGRAM  
FOR NON-DESTRUCTIVE INSPECTION OF COMPOSITE STRUCTURES.

(7156) TITLE - ULTRASONICALLY ASSISTED MACHINING FOR SUPERALLOYS 300 60

PROBLEM - MANY HELICOPTER PARTS ARE EXPENSIVE TO MACHINE.

SOLUTION - EMPLOY ULTRASONICS TO ASSIST MACHINING OPERATIONS OF HARD TO  
MACHINE COMPONENTS.

(7345) TITLE - IN-PROCESS CONTROL OF RESIN MATRIX CURE 265 200

PROBLEM - CONVENTIONAL CONTROL OF THE CURE STAGE DURING COMPOSITE HARDWARE  
MANUFACTURING IS ATTAINED THROUGH MANUAL OR AUTOMATIC CONTROL OF THE  
AUTOCLAVE/PRESS TEMPERATURE AS A FUNCTION OF TIME. THIS METHOD IGNORES THE  
CHEMICAL STATE OF THE RESIN DURING CURE.

SOLUTION - USE IN-PROCESS CONTROL TECHNIQUES CAPABLE OF MONITORING THE RESIN  
FLOW/CURE BEHAVIOR TO INSURE PRODUCTION OF COMPONENTS HAVING CONSISTENTLY  
HIGH QUALITY.

\*\*\*\*\*  
\* C A T E G O R Y \*  
\*-----\*  
\*TURBINE ENGINE \*  
\*\*\*\*\*

COMPONENT -- CERAMIC COMPONENTS

(7268) TITLE - CERAMIC TURBINE STATOR PARTS 875 1510

PROBLEM - EXPENSIVE ALLOYS WITH EXOTIC ELEMENTS ARE CURRENTLY REQUIRED TO  
EXTEND THE OPERATING TEMPERATURE OF METALLIC ENGINE COMPONENTS TO 2500 F.

SOLUTION - DEVELOP AND DEMONSTRATE THE ECONOMICAL OPERATION OF CERAMIC  
COMPONENTS FOR HIGH TURBINE TEMPERATURE APPLICATION.

(7350) TITLE - CERAMIC COMPONENTS FOR TURBINE ENGINES 2860 2200 1100

PROBLEM - METAL BLADES/VANES FOR TURBINE ENGINES ARE HIGH COST, USE CRITICAL  
MATERIALS, AND HAVE UNACCEPTABLE TEMPERATURE LIMITATIONS. CERAMIC MATERIALS  
WHICH HAVE BETTER PROPERTIES ARE NOT USED BECAUSE OF NON-REPRODUCABLE  
PROPERTIES AND SHAPE LIMITATIONS.

SOLUTION - SILICON NITRIDE FORMED BY INJECTION MOLDING AND REACTION BONDING IS  
SUITABLE FOR VANES, AND SILICON CARBIDE FORMED BY INJECTION MOLDING AND  
PRESSURELESS SINTERING HAS TEMPERATURE AND PRESSURE CHARACTERISTICS SUITABLE  
FOR BLADES.

FUNDING (\$000)

PRIOR 80 81 82 83 84

COMPONENT -- CERAMIC COMPONENTS (CONTINUED)

(7400) TITLE - ZIRCONIA SHROUD PRODUCTION SCALE-UP

300 210

PROBLEM - THE ABILITY TO PRODUCE IMPROVED PERFORMANCE ZIRCONIA TURBINE SHROUDS IN A PRODUCTION ENVIRONMENT HAS NOT BEEN DEMONSTRATED.

SOLUTION - THIS PROJECT WILL DEVELOP A SCALED-UP AND REPRODUCIBLE MANUFACTURING PROCESS FOR THERMALLY SPRAYED ZIRCONIUM OXIDE.

COMPONENT -- COMBUSTOR

(7322) TITLE - LOW COST TRANSPIRATION COOLED COMBUSTOR LINER

100 250 300

PROBLEM - COMBUSTOR LINERS OF ADVANCED GAS TURBINE ENGINES ARE REQUIRED TO SURVIVE USING LESS COOLING AIRFLOW THAN HERETOFORE AVAILABLE. STATE OF THE ART TRANSPIRATION COOLED LINERS CAN MEET THE REQUIREMENTS BUT MANUFACTURING PROCESSES ARE NOT COST EFFECTIVE.

SOLUTION - REFINE A LOW-COST MANUFACTURING TECHNIQUE TO FORM THE NECESSARY COMPLEX SHAPES AND COOLING PASSAGES. PROCESS WILL BE USABLE WITH COMMON COMBUSTOR LINER ALLOYS TO BE CONSISTENT WITH THE LOW-COST CONCEPT BEING PURSUED. JOINING WILL ALSO BE REFINED.

COMPONENT -- COMPRESSOR

(7036) TITLE - MM+T-ISOTHERMAL ROLL FORGING OF COMP BLADES

568 310

PROBLEM - TECHNOLOGY FOR FABRICATING ADVANCED ENGINE MATERIALS INTO COMPRESSOR BLADE CONFIGURATIONS IS EITHER UNAVAILABLE OR EXCESSIVE IN COST.

SOLUTION - ISOTHERMAL ROLL FORGING IS A UNIQUE FABRICATION PROCESS CAPABLE OF PRODUCING SHAPES FREE FROM SURFACE CONTAMINATION WITH SURFACE FINISHES EQUAL TO COLD FORGING AT REDUCED COSTS.

(7143) TITLE - MFG OF SPRAY ABRADABLE GAS PATH SEAL SYSTEM

300 435

PROBLEM - METALLIC SYSTEMS CURRENTLY USED IN HIGH PRESSURE TURBINE SEALS DEGRADE DUE TO EROSION, CORROSION, AND ADVERSE RUB BEHAVIOR RESULTING IN INCREASED CLEARANCES OVER THE TURBINE BLADE TIPS AND LOSS OF ENGINE PERFORMANCE.

SOLUTION - EXTENSIVE R+D WORK HAS BEEN PERFORMED UNDER NASA, ARMY, + NAVY CONTRACTS, AND IR+D TO DEVELOP VARIOUS CERAMIC SEAL MATERIAL SYSTEMS. MANUFACTURING PROCESS PARAMETERS WILL BE ESTABLISHED FOR PLASMA-SPRAYED ZIRCONIUM OXIDE SEAL COMPONENTS.

FUNDING (\$000)

PRIOR 80 81 82 83 84

COMPONENT -- COMPRESSOR

(CONTINUED)

(7285) TITLE - MMT-CAST TITANIUM IMPELLER FOR TURBINE ENGINE 435 270 200

PROBLEM - CURRENT CENTRIFUGAL COMPRESSOR IMPELLERS ARE FABRICATED BY MACHINING THE FLOWPATH AND BLADE SURFACES FROM A FORGING. THIS RESULTS IN A SUBSTANTIAL LOSS OF MATERIAL AND EXPENSIVE MACHINING OPERATIONS.

SOLUTION - ESTABLISH THE FABRICATION OF TITANIUM COMPRESSOR IMPELLERS BY CASTING AND HOT-ISOSTATIC PRESSING (HIP). THIS METHOD WILL REDUCE FABRICATION COSTS BY 40 PERCENT. IR+D CONDUCTED BY GAS TURBINE ENGINE MANUFACTURERS HAS DEMONSTRATED FEASIBILITY.

(7291) TITLE - MMT-TITANIUM POWDER METAL COMPRESSOR IMPELLER 90 240 240 250

PROBLEM - WHEN COMPLEX CONFIGURATIONS, SUCH AS CENTRIFUGAL IMPELLERS AND COMPRESSOR ROTORS ARE UTILIZED IN GAS TURBINE ENGINES, TYPICALLY HIGH MANUFACTURING COST ARE ENCOUNTERED.

SOLUTION - DEVELOP OVERALL PROCESS CONTROLS CAPABLE OF REPRODUCIBLY PRODUCING 100 % DENSE PARTS WITH TENSILE, AND FATIGUE STRENGTHS EQUAL TO THOSE OF HIGH QUALITY TITANIUM FORGINGS.

(7364) TITLE - RECOVERING DAMAGED T700 COMPRESSOR BLISKS 250 450

PROBLEM - BLISKS (INTEGRAL BLADES AND DISKS) ARE USED IN THE T700 ENGINE COMPRESSOR STAGES 1 THRU 5. DAMAGE TO ANY ONE BLADE DURING MANUFACTURING OR IN THE FIELD RESULTS IN SCRAPPING THE WHOLE BLISK.

SOLUTION - USE OF PRESSURE BONDING TO REPLACE DAMAGED AIRFOILS WILL PROVIDE PROPERTIES EQUAL TO THE PARENT METAL. HIGH FREQUENCY INDUCTION HEATING WITH SIMULTANEOUS APPLICATION OF PRESSURE HAS BEEN DEMONSTRATED TO BE FEASIBLE FOR BLISK APPLICATIONS.

COMPONENT -- GENERAL

(7200) TITLE - MMT-COMPOSITE ENGINE PARTICLE SEPARATOR 400 100 350

PROBLEM - CURRENTLY, FABRICATION OF THE T700 INLET PARTICLE SEPARATOR (IPS) INVOLVES MACHINING OF CASTINGS AND FORGINGS AND THE JOINING OF THESE PARTS BY WELDING AND BRAZING. THIS IS COSTLY IN TERMS OF BOTH MATERIAL AND LABOR.

SOLUTION - ESTABLISH A NEW PROCESS TO FABRICATE THE IPS FROM INJECTION MOLDED THERMOPLASTIC COMPOSITE, COMBINED WITH HIGH MODULUS, HIGH STRENGTH THERMOSETTING COMPOSITE (GRAPHITE-POLYIMIDE). THIS WILL PROVIDE WEIGHT AND MONETARY SAVINGS.

PRIOR 80 81 82 83 84  
-----

COMPONENT -- GENERAL

(CONTINUED)

(7248) TITLE - CLOSED LOOP MACHINING, MID-FRAME

PROBLEM - THE ENGINE MID-FRAME HAS 22 DIAMETERS WITH TOLERANCES RANGING FROM .001 IN. THESE TOLERANCES RESULT IN HIGH MACHINING, REWORK AND INSPECTION COSTS.

SOLUTION - DEVELOP CLOSED LOOP MACHINING THAT WILL AUTOMATICALLY COMPENSATE FOR ANY DEVIATION IN NUMERICAL CONTROLLED PROGRAMMED PLAN THEREBY REDUCING PRODUCTION COSTS.

540 420

COMPONENT -- MISC COMPONENTS

(7286) TITLE - MMT-HIGH QTY SUPERALLOY POWDER FOR TURBINE COMPNT

PROBLEM - WITH THE COMMITMENT OF GAS TURBINE ENGINE MANUFACTURERS TO THE PRODUCTION OF ENGINE HARDWARE FROM SUPER-ALLOY POWDER THE NEED TO IMPROVE POWDER CLEANLINESS HAS BEEN RECOGNIZED.

SOLUTION - REDUCING THE LEVEL OF NON-METALLIC INCLUSIONS AND THERMALLY INDUCED POROSITY (TIP) WILL INCREASE THE YIELD OF USEFUL POWDER AND PERMIT HIGHER DESIGN LIMITS. IMPURITIES WILL BE REDUCED AT ALL POSSIBLE STAGES IN THE PROCESS, BEGINNING WITH INGOT MELT.

556 120

(7377) TITLE - SPF/DB STATIC STRUCTURE FOR TURBINE ENGINES

PROBLEM - TITANIUM STATIC COMPONENTS OF TURBINE ENGINES USE FORGINGS OR CASTINGS WELDED TO SHEET STOCK AND MACHINED ALL OVER. THIS PROCESS IS TOO COSTLY AND HAS POOR UTILIZATION OF CRITICAL MATERIAL.

SOLUTION - ADAPT THE SPF/DB TECHNOLOGY TO THE MANUFACTURE OF A TITANIUM STATIC COMPONENT OF A TURBINE ENGINE.

407

(7384) TITLE - COMPOSITE ENGINE GEARBOX

PROBLEM - COMPOSITE HOUSINGS HAVE BEEN SHOWN TO BE SUCCESSFUL, BUT THE PROTOTYPE HOUSING FABRICATION PROCESS IS NOT AMENABLE TO THE PRODUCTION ENVIRONMENT.

SOLUTION - ESTABLISH A COST EFFECTIVE FILAMENT WINDING MANUFACTURING METHOD FOR A GRAPHITE FIBER/HIGH TEMPERATURE RESIN COMPOSITE HOUSING.

375

COMPONENT -- SEALS

(7366) TITLE - SPIRAL SELF-ACTING SEAL

PROBLEM - LABYRINTH SEALS HAVE HIGH LEAKAGE RATES AND CAUSE SIGNIFICANT POWER LOSS. T700 DATA SHOW ENGINE POWER LOSSES OF 2-17 PCT DUE TO THE SEAL LEAKAGE. ACCURACY OF GROOVES AND PARALLELISM OF FACES NEED TO BE DEVELOPED.

SOLUTION - DEVELOP MAN TECH NECESSARY FOR FABRICATION OF SPIRAL GROOVE SELF ACTING SEALS. R+D HAS DEMONSTRATED THE HIGH-SPEED, LOW-WEAR, AND LOW-LEAKAGE CAPABILITY OF THE SPIRAL SEAL.

265 200

MNT FIVE YEAR PLAN  
RCS DRCMT 126

FUNDING (\$000)

PRIOR 80 81 82 83 84  
-----

COMPONENT -- SEALS

(CONTINUED)

(7410) TITLE - SMALL ENGINE TURBINE SEAL OPTIMIZATION

PROBLEM - EFFICIENCIES OF SMALL GAS TURBINES ARE EXTREMELY SENSITIVE TO OPERATING CLEARANCES BETWEEN COMPRESSOR AND BLADE TIPS AND THE STATIONARY SEAL COMPONENTS.

SOLUTION - THIS PROJECT WILL DEVELOP THE TECHNOLOGY FOR UTILIZING A DUAL DENSITY PLASMA-SPRAYED CERAMIC SEAL. THE CHEMISTRY OF THE COATING WILL BE OPTIMIZED ALONG WITH THE POWDER MANUFACTURING PROCESS.

330 250

COMPONENT -- TURBINE BLADES

(7356) TITLE - COATINGS FOR UPGRADING PERF. OF GAS TURBINE ALLOYS

PROBLEM - THERMAL EXPANSION COEFFICIENT MISMATCH BETWEEN THE BOND AND CERAMIC LAYER RESULTS IN THERMAL STRESS CRACKING WITH SUBSEQUENT SPALLING WITHIN THE CERAMIC OVERLAY. R+D BY PRIVATE INDUSTRY HAS SHOWN THE FEASIBILITY OF THERMAL BARRIER CERAMIC OVERLAYS.

SOLUTION - ESTABLISH MANUFACTURING TECHNOLOGY FOR PRODUCING IMPROVED COATINGS ON NICKEL BASED SUPERALLOYS. PLASMA SPRAYED TECHNIQUES WILL BE UTILIZED TO OPTIMIZE A NI-CR-AL-Y CERAMIC THERMAL BARRIER OVERLAY BY ADDING AN INTERMEDIATE LAYER ON THE BLADES.

115 125

(7371) TITLE - INTEGRATED BLADE INSPECTION SYSTEM (IBIS)

PROBLEM - INSPECTION OF TURBINE ENGINE BLADES AND VANES NECESSITATES HIGH ACCURACY. THE EFFORT IS TIME CONSUMING AND SUSCEPTABLE TO ERROR.

SOLUTION - THIS PROJECT WILL IMPROVE THE INFRARED, X-RAY, AND INFRARED THERMOGRAPHY INSPECTION MODULES BY INCREASING RELIABILITY, REPEATABILITY AND SENSITIVITY. ALSO, INSPECTION COSTS WILL BE REDUCED.

212 100 357 654

COMPONENT -- TURBINE DISKS

(7361) TITLE - COMPUTER AIDED HIP OF ENGINE DISKS

PROBLEM - MOST ENGINE DISKS ARE PRODUCED FROM TITANIUM AND SUPERALLOYS BY FORGING AND MACHINING AT CONSIDERABLE COST. HOT ISOSTATIC PRESSING (HIP) IS AN APPLICABLE NEAR NET SHAPE PROCESS BUT IT REQUIRES EXPENSIVE TRIAL AND ERROR RUNS FOR THE PREFORMS.

SOLUTION - A COMPUTER-AIDED DESIGN TECHNIQUE WILL BE DEVELOPED FOR ACCURATE DESIGN OF HIP PREFORMS. THIS TECHNIQUE WILL SIMULATE THE SIMULTANEOUS DENSIFICATION AND HEAT TRANSFER DURING A HIP CYCLE. RECENT WORK HAS SHOWN THE FEASIBILITY OF THIS APPROACH.

325 300

FUNDING (\$000)

PRIOR 80 81 82 83 84  
-----

COMPONENT -- TURBINE ROTORS

(7191) TITLE - COST EFFECTIVE PRODUCTION OF COOLED TURBINE ROTORS

440

PROBLEM - PRODUCTION PROCESSES AND QUALITY CONTROL PROCEDURES DO NOT CURRENTLY EXIST FOR AIR-COOLED TURBINE ROTORS.

SOLUTION - DEVELOP A COST EFFECTIVE PROCEDURE FOR PRODUCING AND ASSURING THE QUALITY OF SINGLE AIR-COOLED ROTORS WHICH CAN DO THE WORK OF TWO STAGES UNDER PRESENT TECHNOLOGY.

(7197) TITLE - FABRICATION OF INTEGRAL ROTORS BY JOINING

400 100 350

PROBLEM - CURRENT GAS TURBINE ROTORS ARE EITHER INTEGRALLY CAST OR THE BLADES AND DISKS ARE SEPARATE UNITS. THE BLISK CONCEPT DOES NOT PERMIT OPTIMUM MECHANICAL PROPERTIES OF THE UNIT AND THE OTHER METHOD REQUIRES COMPLEX AND EXPENSIVE MACHINING.

SOLUTION - A BONDED BLADE AND DISK IS FEASIBLE AND WILL REDUCE THE MAJOR MACHINING REQUIREMENTS, STRESS CONCENTRATIONS, AND SIZE AND WEIGHT CONSTRAINTS ON THE DESIGN. THIS ALSO ALLOWS MATERIAL SELECTION TO BE BASED ON PERFORMANCE RATHER THAN JOINING CAPACITY.

(7300) TITLE - IMPROVED LOW CYCLE FATIGUE CAST ROTORS

350 300 300

PROBLEM - INTEGRALLY CAST TURBINE ENGINE ROTORS HAVE BEEN SHOWN TO BE COST EFFECTIVE. HOWEVER, INVESTMENT CASTING RESULTS IN LARGE GRAIN SIZES IN THE DISK REGION AND THIS REDUCES FATIGUE LIFE COMPARED TO WROUGHT MATERIAL.

SOLUTION - DEFINE CASTING AND HEAT TREAT PARAMETERS, AND FINALIZE THE MANUFACTURING TECHNOLOGY FOR ESTABLISHING FINE-GRAINED CAST ROTOR PRODUCTION UTILIZING GRAIN-REFINEMENT TECHNIQUES.

(7351) TITLE - COMPOSITE SHAFTING FOR TURBINE ENGINES

300 300

PROBLEM - CURRENT MATERIAL CAPABILITIES ASSOCIATED WITH HIGH SPEED GAS TURBINE ENGINE SHAFTING REQUIRE EXCESS BEARINGS AND CAREFUL DESIGN REGARDING SHAFT DYNAMICS.

SOLUTION - RECENT DEVELOPMENTS IN FABRICATING METAL MATRIX COMPOSITE SHAFTING OFFER INCREASED STIFFNESS AND CRITICAL SPEEDS BY 30-40 PERCENT AND CAN REDUCE THE DIAMETER.

(7401) TITLE - CAST IMPELLER AND CLEAN CASTING

685 525

PROBLEM - INVESTMENT CAST METAL HAS NUMEROUS SOURCES OF NON-METALLIC CONTAMINATION DURING CONVENTIONAL PROCESSING. THE RESULTING INCLUSIONS REDUCE CASTING PROPERTIES OR INCREASE CASTING COST BY REQUIRING WELD REPAIR.

SOLUTION - THIS PROJECT WILL SEEK TO IDENTIFY AND ELIMINATE THE MAJOR CAUSES OF NON-METALLIC INCLUSIONS IN CASTINGS. THE FINDINGS WILL BE APPLIED TO THE CASTING OF HIGH STRENGTH INCO 718 IMPELLERS AND OTHER CRITICAL COMPONENTS.

MMT FIVE YEAR PLAN  
RCS DRCMT 126

FUNDING (\$000)

PRIOR 80 81 82 83 84

COMPONENT -- TURBINE ROTORS

(CONTINUED)

(7411) TITLE - SECOND GENERATION DUAL PROPERTY TURBINE ROTORS

330 350

PROBLEM - SECOND GENERATION TURBINE DESIGNS COULD BECOME SIGNIFICANTLY MORE ATTRACTIVE IN COST AND PERFORMANCE BY IMPLEMENTATION OF ADVANCED MATERIALS AND DESIGN CONCEPTS.

SOLUTION - FABRICATE SECOND GENERATION DISKS BY THE LOWER COST CAP (CONSOLIDATION BY ATMOSPHERIC PRESSURE) TECHNIQUE. MANUFACTURE IMPINGEMENT TUBES BY CASTING THEM AS AN INTEGRAL COMPONENT.



**COMMUNICATIONS R&D COMMAND  
(CORADCOM)**

<u>CATEGORY</u>	<u>PAGE</u>
Detectors -----	123
Displays -----	123
Frequency Control -----	123
General -----	124
Integrated Electronics -----	126
Optics -----	127
Solid State -----	127

US ARMY COMMUNICATIONS RESEARCH AND DEVELOPMENT COMMAND

(CORADCOM)

The US Army Communications Research and Development Command (CORADCOM), headquartered at Ft. Monmouth, NJ, is responsible for research, development, first production, and initial fielding of communications, tactical data, and command and control systems for the Army. CORADCOM consists of laboratory and technical support segments and Project Managers of Multi-Service Communications System (MSCS), Army Tactical Communications System (ATACS), and project managed elements of Army Tactical Data Systems (ARTADS), i.e., Tactical Fire Control System (TACFIRE), Missile Minder (AN/TSQ-37), Tactical Operations System (TOS), and Position Location Reporting System (PLRS).

CORADCOM's planned projects cover a variety of electronics problems with special emphasis being placed on computer applications and circuit technology. Project 3036 supports efficient manufacturing of custom components for use in future tactical radios.

Video disc information storage is a possible technology for an electronic system for the dissemination of training, technical, and doctrinal data. Project 3042 will investigate methods to reduce the cost of mastering and duplicating the discs.

Projects 3047 and 3048 will supply the necessary manufacturing technology for the precision crystals and temperature compensated oscillators needed to meet the frequency stability requirements of future Army tactical radios.

Program funding in the out-years largely anticipates micro-electronics as the driving force in componentry and built-in test capability for command, control, and communications systems. Computer-dominated methodologies are inherent in such areas as design, manufacture, and manufacturing documentation for communications systems and are expected to be of particular worth for the short lead time, relatively low volume production anticipated for future equipment and systems.

CORADCOM

C O M M A N D F U N D I N G S U M M A R Y  
(THOUSANDS)

CATEGORY -----	FY80 ----	FY81 ----	FY82 ----	FY83 ----	FY84 ----
DETECTORS	0	0	0	612	0
DISPLAYS	0	777	950	0	0
FREQUENCY CONTROL	0	1929	827	600	0
GENERAL	805	0	120	800	2200
INTEGRATED ELECTRONICS	20	250	1495	1000	1400
OPTICS	0	670	0	0	0
SOLID STATE	0	0	500	0	0
TOTAL	825	3626	3892	3012	3600

MMT FIVE YEAR PLAN  
RCS DRCMT 126

FUNDING (\$000)

PRIOR 80 81 82 83 84

-----

612

\*\*\*\*\*  
\* C A T E G O R Y \*  
\*-----\*  
\*DETECTORS\*  
\*\*\*\*\*

COMPONENT -- PHOTO/OPTICAL

(3050) TITLE - III-V SEMICONDUCTOR PHOTODETECTORS

PROBLEM - INTRINSIC AND INDUCED LOSSES LIMIT RANGE OF FIBER OPTIC TRANSMISSION. PRODUCTION MEANS WILL BE NEEDED FOR PHOTODETECTOR CAPABLE OF OPERATION IN SPECTRAL REGION INTRINSICALLY LESS SUSCEPTIBLE TO SUCH LOSSES.

SOLUTION - THIS PROJECT WILL ESTABLISH PRODUCTION TECHNIQUES FOR FORMATION OF A QUATERNARY III-V SEMICONDUCTOR PHOTODIODE WITH GUARD RING, SEMIAUTOMATIC ATTACHMENT AND MOUNTING AND AUTOMATIC TESTING OF THE ASSEMBLY.

\*\*\*\*\*  
\* C A T E G O R Y \*  
\*-----\*  
\*DISPLAYS\*  
\*\*\*\*\*

COMPONENT -- MISCELLANEOUS

(3056) TITLE - ELECTROLUMINESCENT NUMERIC MODULE

PROBLEM - HIGH CONTRAST NUMERIC READOUTS ARE REQUIRED FOR SUNLIGHT LEGIBILITY AND FULL ENVIRONMENTAL OPERATION IN TACTICAL EQUIP. ELECTROLUMINESCENT MODULES NEEDED TO FULFILL THIS REQUIREMENT ARE AVAILABLE ONLY AS SMALL QTY. HIGH COST, LAB BUILT SAMPLES.

SOLUTION - THIN FILM CIRCUITRY TECHNIQUES AND HYBRID ASSEMBLY PROCEDURES WILL BE USED TO ACHIEVE AN EFFICIENT HIGH YIELD MFG TECHNOLOGY CAPABLE OF PRODUCING RELIABLE FULLY MILITARIZED NUMERIC DISPLAY DEVICES AT REASONABLE COST FOR LARGE VOLUME USAGE.

(3073) TITLE - TACTICAL GRAPHICS DISPLAY PANEL

PROBLEM - FABRICATION OF ELECTROLUMINESCENT DISPLAY PANELS REQUIRES REPRODUCIBLE DEPOSITIONS OF ELECTROLUMINESCENT PHOSPHOR DIELECTRIC LAYER AND TRANSPARENT CONDUCTORS. INTERCONNECTION OF INTEGRATED DRIVER AND SHIFT REGISTER CIRCUITS IS NECESSARY.

SOLUTION - UNIFORM REPEATABLE THIN FILM DEPOSITIONS WILL BE ESTABLISHED OVER SUBSTRATE SIZES UP TO 12 INCH DIAGONAL MEASURE. COST WILL BE REDUCED BY OPTIMUM CLEANING, HANDLING, AND PRODUCTION SEALING TECHNIQUES.

\*\*\*\*\*  
\* C A T E G O R Y \*  
\*-----\*  
\*FREQUENCY CONTROL\*  
\*\*\*\*\*

777

950

COMPONENT -- CRYSTALS

(3047) TITLE - LOW COST HIGH STABILITY QUARTZ RESONATORS 600

PROBLEM - SINGGARS FREQUENCY STABILITY REQUIREMENTS CANNOT BE MET WITH PRESENTLY AVAILABLE MASS PRODUCED CRYSTALS. HAND PICKED, LOW YIELD CRYSTALS ARE REQUIRED AND EQUIPMENT PRODUCTION PROBLEMS WILL ARISE DUE TO A SHORTAGE OF PRECISION CRYSTALS.

SOLUTION - ACHIEVE THE TECHNOLOGY NECESSARY TO PRODUCE LARGE QUANTITIES OF HIGH STABILITY,LOW COST CRYSTALS.

(3057) TITLE - HIGH STABILITY VIBRATION RESISTANT QUARTZ CRYSTALS 1157

PROBLEM - CURRENT CRYSTAL RESONATORS SHOW FREQUENCY CHANGES WITH ACCELERATION. THIS IS A SERIOUS PROBLEM WHERE THE RESONATOR MUST OPERATE IN A VIBRATORY ENVIRONMENT. CONSEQUENCES ARE ESPECIALLY SEVERE WHEN EQUIPMENT MUST OPERATE IN A JAMMING ENVIRONMENT.

SOLUTION - DOUBLY ROTATED QUARTZ CRYSTAL RESONATORS, PARTICULARLY THE SC-CUT, HAVE A MUCH LOWER SENSITIVITY TO MECHANICAL STRESS THAN THE COMMONLY USED (SINGLY ROTATED) AT-CUT. BASED ON R+D AND OTHER INFORMATION PRODUCTION TECHNIQUES WILL BE DEVELOPED.

(9851) TITLE - TACTICAL MINIATURE CRYSTAL OSCILLATORS 772

PROBLEM - STATE-OF-THE-ART PRECISION QUARTZ OSCILLATORS DO NOT MEET THE PERFORMANCE, PRODUCTIBILITY, AND COST CRITERIA.NEEDED FOR PLANNED EQUIPMENT. TACTICAL MINIATURE CRYSTAL OSCILLATOR (TMXO) IS HIGH PERFORMANCE BUT REQUIRES NEW PRODUCTION TECHNIQUES.

SOLUTION - ESTABLISH QUALITY CONTROL PROCEDURES AND COST EFFECTIVE PROCESSES FOR ASSEMBLY, OUTGASSING, SEALING, AND TESTING PRODUCTION TMXO. ALSO, DESIGN AND FABRICATE SPECIAL FIXTURING AND TOOLING FOR IMPLEMENTING MANUFACTURING PROCESSES UNIQUE TO TMXO.

COMPONENT -- OSCILLATORS

(3048) TITLE - MICROPROCESSOR COMPENSATED CRYSTAL OSCILLATOR 827

PROBLEM - LOW POWER TEMPERATURE COMPENSATED CRYSTAL OSCILLATORS WITH STABILITY (1-5X10E-7) SUITABLE FOR USE IN JAM PROOF ARMY RADIOS (SFH SINGGARS) ARE NOT AVAILABLE IN PRODUCTION QUANTITIES.

SOLUTION - ESTABLISH PRODUCTION CAPABILITY FOR COST EFFECTIVELONG LIFE, STABLE TCXO'S WHICH UTILIZE MICROPROCESSOR FOR TEMPERATURE COMPENSATION FUNCTION.

\*\*\*\*\*  
\* C A T E G O R Y \*  
\*-----\*  
\*GENERAL\*  
\*\*\*\*\*

COMPONENT -- MATERIALS

(9874) TITLE -- PULSE PLATING OF MULTILAYER PLATED THROUGH HOLES

600

PROBLEM - CIRCUIT BOARD MATERIALS AND PLATED COPPER HAVE DIFFERENT THERMAL COEFFICIENTS OF EXPANSION. WIDE TEMPERATURE EXCURSIONS CAUSE FRACTURE OF THE PLATED COPPER.

SOLUTION - USE THE PULSED PLATING PROCESS TO GET A MORE DUCTILE COPPER INSIDE THE HOLE. VARY CURRENT AND DUTY CYCLE TO OBTAIN AN OPTIMUM RANGE? TEST FOR DUCTILITY, ADHESION, AND RESISTIVITY.

COMPONENT -- MISCELLANEOUS

(3042) TITLE - MASTERING AND DUPLICATION OF VIDEO DISCS

500

PROBLEM - THE HIGH COST OF MASTERING AND DUPLICATING OF VIDEO DISCS HAS RESTRICTED THE USE OF THE TECHNOLOGY IN HIGH PAYOFF TRAINING AND MAINTENANCE OPERATIONS.

SOLUTION - THIS PROJECT WILL PROVIDE METHODS AND TECHNIQUES FOR LOW-COST MASTERING AND DUPLICATION OF VIDEO DISCS.

(3051) TITLE - ACCELERATED/OVERSTRESS TESTING

200

PROBLEM - NEW DOD POLICY DICTATES A SHORTENED PROCUREMENT CYCLE. THEREFORE, WHAT IS NEEDED IS A TECHNIQUE FOR THE DEMONSTRATION OF REQUIRED LEVELS OF RELIABILITY IN A SIGNIFICANTLY REDUCED PERIOD OF TIME WITH A RESULTANT TEST COST SAVINGS.

SOLUTION - THE OBJECTIVE OF THIS PROGRAM IS TO DEVELOP CORRELATION FACTORS WHICH RELATE LABORATORY ACCELERATED / OVERSTRESS TEST CONDITIONS TO FIELD ENVIRONMENTAL FACTORS.

(3059) TITLE - INTELLIGENT TERMINALS & PERIPHERALS FOR MILITARY COMPUTERS

1700

PROBLEM - THERE IS A NEED TO ESTABLISH A PRODUCTION CAPABILITY TO MANUFACTURE TO FORM, FIT, AND FUNCTION INTELLIGENT TERMINALS AND PERIPHERALS FOR THE MILITARY COMPUTER FAMILY.

SOLUTION - OBTAINING THIS CAPABILITY WILL PERMIT THE FABRICATION OF COST EFFECTIVE TERMINALS AND PERIPHERALS WITH IMPROVED FLEXIBILITY, INTEROPERABILITY, SURVIVABILITY AND REDUCED ACQUISITION TIME.

(3069) TITLE - FUNCTIONAL SEGMENTATION OF AUTO TEST EQUIP

120

PROBLEM - ARMY ELECTRONIC ITEMS MUST BE TESTED ON EXPENSIVE AUTOMATIC TESTERS THAT CONTAIN MORE CAPABILITY THAN NEEDED AND COST MORE THAN MOST FIRMS CAN AFFORD.

SOLUTION - RECONFIGURE THE AN/USM-410 EQUATE TESTER TO PERMIT A MINIMUM OF MODULES TO DO SOME LOW ORDER TESTING AND PERMIT ADD-ONS TO BE ADDED TO UPGRADE THE GEAR TO HANDLE ADDITIONAL TESTS AS NEEDED. WORK ON SOFTWARE COMPATIBILITY.

FUNDING (\$000)

PRIOR 80 81 82 83 84  
-----

COMPONENT -- PRINTED CIRCUIT BOARD

(3054) TITLE - PRODUCTION METHODS FOR MULTI-LAYER FOLDED CIRCUITS 805

PROBLEM - DENSE AND HIGHLY RELIABLE ELECTRONICS ARE REQUIRED FOR MILITARY SYSTEMS. CONVENTIONAL MULTI LAYER RIGID CIRCUIT HIGH DENSITY PACKAGING IS LIMITED BY SPECIAL INTERCONNECTIONS AND OTHER PROBLEMS.

SOLUTION - ESTABLISH A SYSTEM FOR PRODUCING MULTI-LAYER, MULTI-FOLDING CIRCUITS WHICH WILL BE ADAPTABLE TO CURRENT AND FUTURE MILITARY SYSTEMS.

\*\*\*\*\*  
\* C A T E G O R Y \*  
\*-----\*  
\* INTEGRATED ELECTRONICS \*  
\*\*\*\*\*

COMPONENT -- AMPLIFIERS

(9835) TITLE - INTEGRATED CONTROL CIRCUIT FOR THIN FILM TRANSISTOR DISPLAY 1049 495

PROBLEM - SEMICONDUCTOR DISPLAY ARRAYS REQUIRE COMPACT YET COMPLEX DRIVE CIRCUITS. A MULTI-STAGE VACUUM METALLIZING SYSTEM IS NEEDED.

SOLUTION - DEVELOP MASK MOUNTING AND CHANGING TECHNIQUES. DEVELOP METHODS FOR CLEANING AND REINSERTING MASKS WITHOUT CHANGING REGISTRATION. PUT PERIPHERAL CIRCUITS ON DISPLAY PANEL.

COMPONENT -- CIRCUITRY

(3036) TITLE - SPECIAL COMPONENTS MFG TECHNIQUES FOR SINGLE CHANNEL RADIOS 20 250 1000 1000

PROBLEM - SEMICONDUCTOR INTEGRATED CIRCUITS NEEDED FOR SPECIAL COMMUNICATIONS EQUIP. MUST BE CUSTOM DESIGNED FOR EACH NEW APPLICATION. EACH IC REQUIRES SEVERAL MASK SETS AND A NUMBER OF IC ARE REQUIRED FOR EACH DEVICE. CONSIDERABLE ARTWORK IS REQUIRED.

SOLUTION - DEVELOP COMPUTER AIDED MANUFACTURING TECHNIQUES THAT WILL REDUCE THE COST OF AND IMPROVE THE RELIABILITY OF SEMICONDUCTOR INTEGRATED CIRCUITS

(3058) TITLE - VHSI & LSI CHIP SETS FOR MILITARY COMPUTER FAMILY MODULES 1400

PROBLEM - THERE IS A NEED FOR CONTINUING DEVELOPMENT OF INTEGRATED CIRCUIT TECHNOLOGY IN THE AREA OF LSI AND VHSI TO PROVIDE CHIP SETS OF MILITARY COMPUTER FAMILY BOXES AND MODULES TO REDUCE SIZE AND COST OF MCF SYSTEMS.

SOLUTION - THE DEVELOPMENT OF LSI AND VHSI CHIP SETS WILL PERMIT MAJOR REDUCTIONS IN MCF SYSTEM SIZE FROM 5-7 BOXES TODAY, DOWN TO ONE BOX IN THE 1990'S. IT WILL ALSO MEAN SIGNIFICANT REDUCTION IN COSTS AND PROVISION OF COMMON BUS INTERFACING.

\*\*\*\*\*  
 \* C A T E G O R Y \*  
 \*-----\*  
 \*OPTICS \*  
 \*\*\*\*\*

MMT FIVE YEAR PLAN  
 RCS DRCMT 126

FUNDING (\$000)

PRIOR 80 81 82 83 84  
 -----

COMPONENT -- FIBER

(9784) TITLE - RUGGEDIZED TACTICAL FIBER OPTIC CABLE ASSEMBLY

670

PROBLEM - APPLYING A PROTECTIVE COATING ONTO EACH FIBER HAS NOT BEEN DONE IN PRODUCTION QUANTITIES. BUNDLING THE FIBERS AND APPLYING A PLASTIC SHEATH MUST BE WORKED OUT.

SOLUTION - DEVELOP EQUIPMENT TO EXTRUDE A PLASTIC KYNAR COVERING ONTO EACH OPTIC FIBER AND EXTRUDE A PROTECTIVE PLASTIC SHEATH OVER THE CABLE. ESTABLISH TERMINATION METHODS.

\*\*\*\*\*  
 \* C A T E G O R Y \*  
 \*-----\*  
 \*SOLID STATE \*  
 \*\*\*\*\*

COMPONENT -- DIODES/RECTIFIERS

(3068) TITLE - INCREASE PROD OF SEMI-CONDUCTOR CONTROL DIODES

500

PROBLEM - PRESENTLY AVAILABLE VARACTORS AND PIN DIODES MADE BY SILICON DIODE TECHNOLOGY ARE EXPENSIVE. THE IR PRODUCTION TECHNIQUES ARE VERY LABOR INTENSIVE, YIELDS ARE LOW, AND UNIFORMITY IS POOR. MATCHING REQUIRES EXTENSIVE TESTING.

SOLUTION - USE GALLIUM ARSENIDE INSTEAD OF SILICON FOR THESE DEVICES USE AUTOMATIC CONTROL SYSTEM FOR PROCESSES INSTEAD OF MANUAL PROCEDURES TO INCREASE YIELD. DEPOSIT A MEDIUM TEMPERATURE PASSIVATION LAYER ON PIN DIODE TO IMPROVE RELIABILITY AND UNIFORMITY.

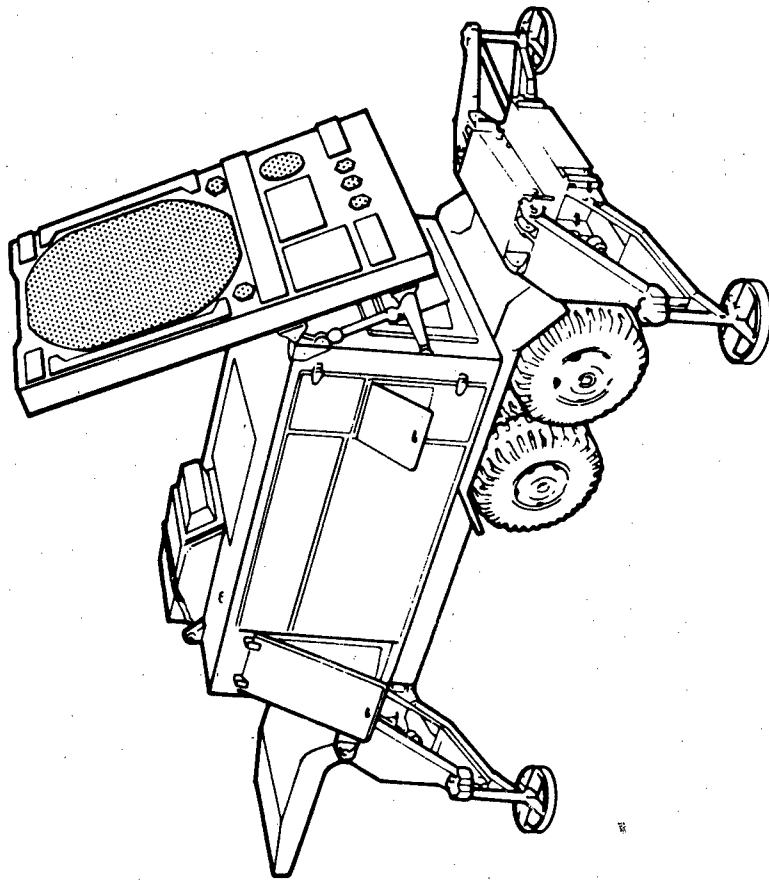

**ELECTRONICS R&D COMMAND  
(ERADCOM)**

<u>CATEGORY</u>	<u>PAGE</u>
Detectors -----	133
Displays -----	134
Electron Tubes -----	136
Frequency Control -----	137
General -----	139
Integrated Electronics -----	140
Laser -----	144
Optics -----	145
Passive Components -----	146
Power Sources -----	147
Solid State -----	148

US ARMY ELECTRONICS RESEARCH AND DEVELOPMENT COMMAND

(ERADCOM)

ERADCOM is the Army's focal point for electronics research, development and acquisition (RDA) activities, and maintains programs in such areas as electronics signal intelligence, electronic warfare, atmospheric sciences, target acquisition and combat surveillance, electronic fuzing, radars, sensors, night vision, radar frequency and optical devices, nuclear weapons effects, instrumentation and simulation, and fluidics.

There are seven laboratories integrated into ERADCOM's structure. These laboratories are product oriented and as a result can identify major problem areas where applied MMT efforts can realize important benefits. Although ERADCOM and its laboratories identify and manage projects, the bulk of the actual work is contracted out to non-Government organizations.

A major area of interest is developing legible tactical displays which are suitable for military use. Because of operational limitations in legibility, power requirements, and weight and poor RAM (reliability, availability and maintainability) characteristics conventional displays are unacceptable. New technologies, such as flat panel displays and ruggedization techniques, which can satisfy these requirements are now in development but need improved manufacturing methods for effective production.

Improving sighting capabilities is an area of prime concern to all the services. Several projects for significant improvements in production techniques for image intensifiers are included in the Plan. The development of millimeter wave and infrared laser systems for all-weather and smoke fighting is being pursued. This will require the development of new control systems and subsystems. New or improved techniques will be needed to insure the necessary quality and quantity of systems. Projects are also included dealing with thermal electro-optical systems. These systems include the present generation Common Modules and future second generation systems such as the ATAC and MISTAF FLIRS (Forward Looking Infrared Systems) and the Thermal Weapon Sight (TWS).

Emphasis is also being placed in high energy pulser systems for use in future defense systems. Pulsers using state-of-the-art components are excessively large, costly, and are not usable for mobil field applications. Results of research and development promise an order of magnitude decrease in size which would allow production of mobile units. Since applications of this system are exclusively military, MMT funding is necessary to establish economical production.

ERADCOM

COMMAND FUNDING SUMMARY  
(THOUSANDS)

CATEGORY	FY80	FY81	FY82	FY83	FY84
-----	----	----	----	----	----
DETECTORS	3112	753	0	300	2100
DISPLAYS	792	617	0	800	3100
ELECTRON TUBES	0	0	1716	1850	1200
FREQUENCY CONTROL	610	0	0	1400	600
GENERAL	15	0	1179	1000	2200
INTEGRATED ELECTRONICS	994	863	1179	4700	5600
LASER	27	523	621	2300	0
OPTICS	0	1310	0	750	600
PASSIVE COMPONENTS	0	0	1004	500	0
POWER SOURCES	885	0	0	650	0
SOLID STATE	892	1152	2329	1200	0
	-----	---- <td>---- <td>---- <td>---- </td></td></td>	---- <td>---- <td>---- </td></td>	---- <td>---- </td>	----
TOTAL	7327	5218	8028	15450	15400

\*\*\*\*\*  
 \* C A T E G O R Y \*  
 \*-----\*  
 \*DETECTORS\*  
 \*\*\*\*\*

MMT FIVE YEAR PLAN  
 RCS DRCMT 126

FUNDING (\$000)

PRIOR 80 81 82 83 84

COMPONENT -- ARRAYS

(5057) TITLE - 3-5 MICRON TE COOLED FOCAL PLANE MODULES

1250

PROBLEM - IMPROVED THERMAL IMAGING EQUIPMENT OPERATING AT 3-5 MICRONS REQUIRE USE OF HIGH DENSITY MATRIX DETECTOR ARRAY IN THE ORDER OF 2000 ELEMENTS. THIS EQUIPMENT CAN'T BE PRODUCED WITH TODAY'S THERMAL IMAGING OFF-FOCAL-PLANE ARRAY TECHNOLOGY.

SOLUTION - INITIATE A PHASED PROGRAM TO ESTABLISH CONTROLLED MANUFACTURING PROCESSES AND TEST METHODS TO PRODUCE INTEGRATED FOCAL PLANE ARRAY COOLER/DEWAR MODULES TO OPERATE AT 195 K. ESTABLISH AND VALIDATE PRODUCTION AND TEST METHODS FOR COMPLETED MODULE.

(5110) TITLE - COMMON MODULE DETECTOR ARRAY

1300 753

PROBLEM - MERCURY-CADMIUM TELLURIDE DETECTOR ARRAYS ARE NOW HAND LAPPED AND POLISHED. CONTACT MASKING IS USED FOR PHOTOLITHOGRAPHY AND WET ETCHING FOR DELINEATION. ALSO, GOLD WIRING IS USED FOR LEADOUTS. THESE ARE LABOR INTENSIVE AND NON-UNIFORM.

SOLUTION - USE SEMICONDUCTOR INDUSTRY PRACTICES OF BATCH MACHINE LAPPING AND POLISHING OF HG-CD-TE WAFERS, PROJECTION PHOTOMASKING, PLASMA ETCHING, ION BEAM MILLING, LEAD-OUT METALLIZATION, AND PLATING. THESE SHOULD PROVIDE UNIFORM RESULTS.

COMPONENT -- INFRARED/UV

(3501) TITLE - THIRD GENERATION PHOTOCATHODE ON FIBER OPTICS

580

PROBLEM - FORM, FIT AND FUNCTION REPLACEMENT OF 2ND GEN. 18 MM AND 25 MM DEVICES WITH 3RD GEN PRODUCT IMPROVEMENT WILL REQUIRE THAT A PRODUCTION TECHNIQUE BE AVAILABLE FOR FABRICATING GA-AS PHOTOCATHODES ON FIBER OPTIC FACEPLATES.

SOLUTION - PROVIDE A PRODUCTION PROCESS FOR 25 MM FIBER OPTICS FACEPLATES WITH PROPER COEFFICIENT OF EXPANSION TO MATCH GA-AS. SEAL GA-AS TO THE FIBER OPTIC AND ACTIVATE PHOTOCATHODE TO HIGH SENSITIVITY USING HIGH RATE OF PRODUCTION TECHNIQUES

(5059) TITLE - MAGNETIC SUSPENSION COOLERS

300

PROBLEM - SECOND GENERATION FLIR'S WILL EMPLOY MAGNETIC SUSPENSIONS IN THE CRYOGENIC COOLERS. MAINTAINING CRITICAL SUSPENSION TOLERANCES IN PRODUCTION WILL REQUIRE DEVELOPING EXTENSIVE QUALITY CONTROL PROCEDURES.

SOLUTION - DEVELOP MANUFACTURING METHODS FOR MAINTAINING CRITICAL TOLERANCES.

(5073) TITLE - ADVANCED MECHANICAL COOLERS FOR 2ND GEN. FLIR'S

850

PROBLEM - SECOND GEN IR SENSORS ARE NOW VERY SUSCEPTIBLE TO VIBRATIONS AND THERMAL FLUCTUATIONS TO A LARGER DEGREE THAN CONVENTIONAL FIRST GEN SYSTEMS.

SOLUTION - DEVELOP MANUFACTURING TECHNIQUES FOR REDUCING THERMAL FLUCTUATIONS AND VIBRATIONS

MMT FIVE YEAR PLAN  
RCS DRCMT 126

FUNDING (\$000)

PRIOR 80 81 82 83 84

COMPONENT -- INFRARED/UV

(CONTINUED)

(9588) TITLE - THIRD GENERATION LOW COST 6066LE TUBE

892

PROBLEM - TYPICAL MANUFACTURING METHODS REQUIRE THE USE OF AN EXCESSIVE AMOUNT OF HAND LABOR WHICH CONTRIBUTES TO HIGH UNIT COSTS FOR THE INTENSIFIER TUBE.

SOLUTION - DETERMINE THE MOST ECONOMICAL METHOD FOR PRODUCING A LOW COST 3RD GENERATION IMAGE INTENSIFIER TUBE. THE METHOD WILL BE PROVED BY PRODUCING A SAMPLE TUBE LOT.

COMPONENT -- SILICON

(5147) TITLE - PROD OF DETECTOR GRADE POLYCRYSTALLINE SILICON

340

PROBLEM - THERE IS A SHORTAGE OF HIGH PURITY TRICHLOROSILANE MATERIAL FOR GROWING INTO POLYSILICON RODS FOR VACUUM FLOAT ZONING INTO HIGH RESISTIVITY SINGLE CRYSTAL BOULES. HIGH PURITY, HIGH RESISTIVITY SILICON IS NEEDED FOR PHOTODETECTORS FOR MUNITIONS.

SOLUTION - ESTABLISH A DOMESTIC SUPPLY OF HIGH PURITY POLYSILICON. REFINE OUT UNWANTED PHOSPHORUS AND ARSENIC FROM TRICHLOROSILANE. MODIFY A REACTOR TO PULL HIGH RESISTIVITY POLY RODS FOR LATER ZONE REFINING INTO SINGLE CRYSTAL RODS. ENHANCE STARTING MTL PURITY

\*\*\*\*\*  
\* C A T E G O R Y \*  
\*-----\*  
\*DISPLAYS \*  
\*\*\*\*\*

COMPONENT -- CRT

(3505) TITLE - HIGH CONTRAST CATHODE RAY TUBE

617

PROBLEM - HIGH CONTRAST CRT AVIONIC DISPLAYS FOR DAY-NIGHT NIGHT VISION GOGGLES ARE CURRENTLY UNAVAILABLE. OPTICAL FILTERS ARE ENVIRONMENTALLY LIMITED FOR THIS APPLICATION. PHOSPHOR TECHNIQUES ARE AVAILABLE BUT OPTIMIZATION AND ECONOMICS HAVE NOT BEEN SHOWN.

SOLUTION - USE OF OPTIMIZED BILAYER TRANSPARENT PHOSPHORS WITH A BLACK ABSORBENT LAYER PROVIDES THE HIGH CONTRAST DISPLAY FOR THE SEVERAL MODES. OPTIMIZATION OF PHOSPHOR TECHNIQUES FOR 5 IN AND LARGER CRT'S WILL BE ECONOMICALLY JUSTIFIED.

(CONTINUED)

COMPONENT -- CRT

(5071) TITLE - TACTICAL COLOR CATHODE RAY TUBE

800

PROBLEM - PRESENTATION OF HIGH DENSITY INFORMATION UNDER TACTICAL CONDITIONS REQUIRES CODING THAT CAN BE PROVIDED BY COLOR. AVAILABLE COLOR CRTS CANNOT SURVIVE TACTICAL CONDITIONS WITHOUT EXPENSIVE AND MARGINALLY EFFECTIVE MODIFICATIONS.

SOLUTION - CRT DISPLAYS CAN BE DESIGNED TO OPERATE UNDER THE VIBRATION, TEMPERATURE AND MAGNETIC ENVIRONMENT OF THE TACTICAL BATTLEFIELD IF THE TOTAL SYSTEM IS DESIGNED FOR THESE CONDITIONS. ECONOMICAL FABRICATION PROCESSES FOR SUCH DISPLAYS MUST BE DEVELOPED.

COMPONENT -- MISCELLANEOUS

(3023) TITLE - MILITARY PLASMA PANEL

792

PROBLEM - PRESENT DISPLAY DEVICE FOR TACFIRE HAS TOO SMALL AND ACTIVE AREA AND INSUFFICIENT INTERACTIVE AND MAP CAPABILITY. TUBULAR PLASMA PANEL CAN BE USED BUT IS HIGH IN COST DUE TO EXTENSIVE LABOR IN PARTS, INSP, ASSEMBLY, AND FINAL INSPECTION.

SOLUTION - EFFICIENT MFG METHODS AND TECHNIQUES WILL BE DEVELOPED TO PRODUCE RELIABLE PLASMA PANEL DISPLAYS. THESE WILL INCLUDE AUTOMATIC METHODS FOR SPACER INSERTION AND ELECTRODE AND DIELECTRIC DEPOSITIONS AS WELL AS THE INCORPORATION OF IN-LINE PROCESSING.

(5036) TITLE - MULTICOLOR GRAPHICS DISPLAY

1200

PROBLEM - TACTICAL MANPACK COMM TERMINALS REQUIRE A LIGHTWEIGHT LOW POWER MULTICOLOR DISPLAY WHICH IS CAPABLE OF GRAPHICS AND IS LEGIBLE IN DIRECT SUNLIGHT. SUCH DISPLAYS ARE PRESENTLY AVAILABLE ONLY AS LABORATORY EVALUATION MODELS AT PROHIBITIVE EXPENSE.

SOLUTION - A MANUFACTURING METHODS PROGRAM MUST BE CONDUCTED SO THAT THESE DISPLAYS CAN BE MANUFACTURED IN LARGE QUANTITIES AT A PRICE WHICH WILL MAKE THEM FEASIBLE FOR TACTICAL USE WHERE THEY ARE BADLY NEEDED.

(5080) TITLE - MINATURE FLAT PANEL 875-LINE DISPLAY

1000

PROBLEM - DOUBLING OF THE RESOLUTION OF THIS DISPLAY OVER THE 525-LINE DISPLAY WILL REQUIRE THE HIGH RESOLUTION ELECTRON LITHOGRAPHY OR X-RAY LITHOGRAPHY IN ORDER TO PRODUCE THEM WITH GOOD YIELD

SOLUTION - DEVELOP PRODUCTION METHODS

COMPONENT -- MISCELLANEOUS

(CONTINUED)

900

(5081) TITLE - INTEGRATED 875-LINE LIQUID CRYSTAL DISPLAY CHIP

PROBLEM - THE FABRICATION OF LIQUID CRYSTAL-SILICON DISPLAY CHIPS WITH AN 875X1163 FORMAT AND INTEGRATED DRIVE ELECTRONICS REPRESENTS A TREMENDOUS NUMBER OF ELEMENTS PER CHIP AND SIGNIFICANT YIELD PROBLEMS

SOLUTION - IMPROVE AND AUTOMATE CONTROL OF MULTI-STEP PROCESS FOR FABRICATING THE DISPLAY CHIPS AND ESTABLISH CAPABILITY FOR LARGER WAFERS WITH MORE CHIPS PER WAFER.

\*\*\*\*\*  
\* C A T E G O R Y \*  
\*-----\*  
\*ELECTRON TUBES \*  
\*\*\*\*\*

COMPONENT -- BEAM

(5010) TITLE - BONDED GRID CONVERGENT ELECTRON GUN

867

PROBLEM - PRESENT TECHNOLOGY CAN NOT BE USED TO BUILD GRIDDED MILLIMETER WAVE TUBES. MUST USE HIGH VOLTAGE MODULATOR FOR PULSED OPERATION.

SOLUTION - THE PROCESSES OF CHEMICAL VAPOR DEPOSITION OF BORON NITRIDE, GRID FABRICATION AND BONDING OF GRIDS TO THE CATHODE BY LOW COST PRODUCTION TECHNIQUES WILL BE DEVELOPED.

(5019) TITLE - LASER-CUT SUBSTRATES FOR MW TUBES

849

PROBLEM - PRESENT CFA JAMMER TUBES EMPLOY HIGH COST, PRECISION ANODE CIRCUITS LIMITING UTILIZATION IN OPTIMIZED EW SYSTEMS. HIGH PERFORMANCE AND LOW WEIGHT AT MINIMUM COST IS REQUIRED TO FIELD DESIRED EW SYSTEMS.

SOLUTION - UTILIZE LASER-CUT ANODE CIRCUIT SUBSTRATES TO ACHIEVE DESIRED RF PERFORMANCE AND MINIMIZE PARTS AND OVERALL DEVICE COST. ALSO EMPLOY PHOTOLITHOGRAPHIC TECHNIQUES TO FORM MEANDERLINE CIRCUIT. USE BERYLLIA SUBSTRATE MATERIAL FOR DIELECTRIC SUPPORTS.

(5029) TITLE - NON-FERRULE CAVITIES FOR MM WAVE AMPLIFIER TUBES

400

PROBLEM - MILLIMETER RADARS REQUIRE LIGHT WEIGHT LOW COST TRANSMITTER TUBES TO PROVIDE SYSTEMS TO PENETRATE SMOKE AND FOG. PRESENT HAND MACHINING IS EXPENSIVE AND POOR TOLERANCE CONTROL AT MM DIMENSIONS RESULT IN HIGH COST TRANSMITTER TUBES EVEN IN LARGE QTY.

SOLUTION - COMPUTER CONTROLLED ZERO BLANK COINING AND LAPPING METHODS WOULD ELIMINATE COSTLY HAND MACH AND HAND STACKING OF CAVITIES SUITABLE FOR MILLIMETER WAVE TUBES. ADAPTING PRESENT TECH AND ASSEMBLY PROC TO ACHIEVE HIGH YIELD WILL PROVIDE A LOW COST TUBE.

COMPONENT -- BEAM (CONTINUED)

(9970) TITLE - LIGHTWEIGHT LOW COST JAMMER PACKAGE

600

PROBLEM - MANUAL ASSEMBLY OF LARGE NUMBER OF PIECE PARTS MAKES TUBES EXPENSIVE. A LARGE AMOUNT OF HIGHLY SKILLED LABOR IS REQUIRED TO PERFORM ROUTINE REPETITIVE TESTS.

SOLUTION - USE AUTOMATIC CONTROL FOR TEMPERATURE AND VACUUM PROCESSING. FABRICATION OF HELIX CIRCUIT AND SUPPORT RODS, AND DEPOSITION OF ATTENUATOR PATTERN ON THE SUPPORT RODS. USE AUTOMATIC TESTING.

COMPONENT -- CATHODE

(5117) TITLE - FIELD EMISSION ELECTRON GUNS

500

PROBLEM - TECHNOLOGY TO BUILD HIGH CURRENT DENSITY LOW VOLTAGE MODULATION ELECTRON GUNS FOR HIGH POWER SUBMILLIMETER WAVE TUBES IS NOT AVAILABLE.

SOLUTION - DEVELOP TECHNIQUES FOR MANUFACTURING HIGH CURRENT DENSITY LOW VOLTAGE ELECTRON GUNS FOR SUBMILLIMETER ELECTRON GUNS CAPABLE OF OPERATING FOR HUNDREDS OF HOURS.

(5131) TITLE - CCD IMAGER FOR 1-2 MICRON WAVELENGTH REGION

1200

PROBLEM - CURRENT TECHNIQUES FOR PRODUCTION ARE COSTLY.

SOLUTION - DEVELOP PRODUCTION TECHNIQUES TO FABRICATE THESE DEVICES IN A COST-EFFECTIVE MANNER.

(9879) TITLE - HIGH CURRENT DENSITY CATHODE

350

PROBLEM - CURRENT DENSITY REQUIRED FOR MILLIMETER WAVE TUBES RESULTS IN VERY SHORT LIFE AND POOR RELIABILITY WITH ANY PRESENTLY AVAILABLE CATHODES.

SOLUTION - PROVIDE MANUFACTURING PROCESS FOR TUNGSTATE CATHODE WHICH AT THE REQUIRED CURRENT DENSITY HAS OVER TEN TIMES THE LIFE OF PRESENTLY AVAILABLE CATHODES.

\*\*\*\*\*  
\* C A T E G O R Y \*  
\*-----\*  
\*FREQUENCY CONTROL \*  
\*\*\*\*\*

COMPONENT -- CRYSTALS

(5055) TITLE - HI RELIABILITY GENERAL PURPOSE CRYSTALS

500

PROBLEM - CRYSTALS USED IN HIGH RELIABILITY TACTICAL RADIOS HAVE A HIGH FAILURE RATE DUE TO FREQUENCY VARIATIONS WITH TIME, TEMPERATURE, SHOCK, AND VIBRATION. LEAKS INTO THE ENCLOSURE ARE A MAJOR PROBLEM.

SOLUTION - PRODUCTION ENGINEERING WILL CLOSELY CONTROL CRYSTAL PLATE GEOMETRY, ORIENTATION, MOUNTING, HERMETIC SEALING AND TESTING OF AT-CUT CRYSTALS.

COMPONENT -- MISCELLANEOUS

(9897) TITLE - SURFACE ACOUSTIC WAVE RESONATOR AND REFLECTIVE ARRAY DEVICES

610

PROBLEM - PRODUCTION TECHNIQUES FOR ACHIEVING DEVICE REPRODUCIBILITY, FREQUENCY TUNABILITY AND LOW COST FOR SAW RESONATORS AND REFLECTIVE ARRAY DEVICES ARE NOT AVAILABLE.

SOLUTION - ESTABLISH PRODUCTION TECHNIQUES AND PROCESS CONTROLS TO PROVIDE SAW RESONATORS AND REFLECTIVE ARRAY DEVICES AT PRECISE FREQUENCIES.

COMPONENT -- OSCILLATORS

(3048) TITLE - MICROPROCESSOR COMPENSATED CRYSTAL OSCILLATOR

400

PROBLEM - STABILITY OF AVAILABLE TEMPERATURE COMPENSATED CRYSTAL OSCILLATORS IS INADEQUATE FOR MAINTAINING NET SYNCHRONIZATION IN SECURE AND JAMPROOF TACTICAL RADIOS DURING BRIEF PERIODS OF RADIO SILENCE (1-5X10-7 REQUIRED).

SOLUTION - ESTABLISH PRODUCTION CAPABILITY FOR COST EFFECTIVE LONG LIFE, STABLE TEMPERATURE COMPENSATED CRYSTAL OSCILLATORS WHICH UTILIZE MICROPROCESSOR FOR TEMPERATURE COMPENSATION FUNCTION TO YIELD THE REQUIRED STABILITY.

(5070) TITLE - MICROPOWER TIME OF DAY SOURCE

500

PROBLEM - MICROPOWER PRECISION TIME OF DAY SIGNAL SOURCES FOR OPERATOR INITIATED SECURE NET ENTRY PROCEDURES ARE NOT AVAILABLE.

SOLUTION - ESTABLISH PRODUCTION CAPABILITY FOR A MICROPOWER PRECISION TIME BASE REFERENCE OSCILLATOR TO BE USED IN ECCM COMMUNICATION RADIO SETS.

(9767) TITLE - DEPOSITION OF THICK FILM CIRCUITS FOR CRYSTAL OSCILLATORS

393

600

PROBLEM - AVAILABLE HIGH SHOCK TEMPERATURE COMPENSATED VOLTAGE CONTROLLED CRYSTAL OSCILLATORS FOR GUN EMPLACED DATA TRANSMITTERS ARE NOT COST EFFECTIVE BECAUSE OF EXPENSIVE MANUFACTURING TECHNIQUES

SOLUTION - DEVELOP LOW COST AUTOMATED MANUFACTURING AND TESTING TECHNIQUES FOR HYBRID MICROCIRCUIT CRYSTAL OSCILLATORS.

\*\*\*\*\*  
 \* C A T E G O R Y \*  
 \*-----\*  
 \*GENERAL\*  
 \*\*\*\*\*

MMT FIVE YEAR PLAN  
 RCS DRCMT 126

FUNDING (\$000)

PRIOR 80 81 82 83 84

COMPONENT -- ALL ELECTRONICS

(5095) TITLE - MFG TECH ASSESSMENT OF ELECTRONICS

15

PROBLEM - AREAS OF OPPORTUNITY FOR INVESTING MMT FUNDS TO IMPROVE PRODUCTIVITY AND REDUCE COST REQUIRE STUDY. COMPUTER AIDED SYSTEMS FOR DESIGN, MANUFACTURE AND TEST OF ELECTRONIC ARE PROPRIETARY AND UN-RELIABLE.

SOLUTION - DEVELOP THE ARCHITECTURE FOR A GENERALIZED COMPUTER CONTROLLED SYSTEM FOR MANUFACTURE OF MILITARY ELECTRONIC EQUIPMENT. USE METHODS AND TOOLS AVAILABLE. SET UP A COMMON DATA BASE, WORK FLOW, HUMAN FACTORS, EFFECT ON BUSINESS STRUCTURE AND PROFITS.

COMPONENT -- COMPONENTS

(5100) TITLE - MANUFACTURING TOLERANCES FOR ANTENNAS

350

PROBLEM - MANUFACTURE OF LOW SIDELOBE ANTENNAS REQUIRED TO OPERATE IN HOSTILE THREAT ENVIRONMENT POSE PROBLEM IN SYNTHESIZING THE APERTURE DISTRIBUTION DUE TO MECHANICAL MANUFACTURING TOLERANCES. LITTLE DATA AVAILABLE TO ASSESS EXISTING MANUFACTURING CONTROL

SOLUTION - DETERMINE WHAT EXISTING MANUFACTURING CONTROLS FOR ANTENNAS NOW ARE AVAILABLE, WHAT IMPROVEMENTS ARE NEEDED, AND WHAT ARE THE MOST PRODUCTION COST EFFECTIVE TECHNIQUES THAT COULD BE USED.

(5107) TITLE - MILLIMETER WAVE POWER SOURCE COMBINER

1179

PROBLEM - DIODE PARAMETERS VARY GREATLY FROM UNIT TO UNIT. PACKAGING METHODS ARE UNSATISFACTORY FOR COMBINER CIRCUITS. TUNING COMBINER ELEMENTS AND ADJUSTING ASSOCIATED MODULATING CIRCUITS TAKES WEEKS OF EFFORT TO OBTAIN REQUIRED PERFORMANCE LEVELS.

SOLUTION - OPTIMIZE FABRICATION PROCESS AND ESTABLISH TECHNIQUES OF DIODE AND PACKAGE PRODUCTION RESULTING IN HIGH YIELDS OF REPRODUCIBLE COMBINER USABLE DEVICES. OPTIMIZE COMBINER CIRCUITS AND MODULATORS FOR HIGH PERFORMANCE AND UNCOMPLICATED TUNINGS.

(5116) TITLE - INTRINSICALLY TEMPERATURE-COMPENSATED MAGNETS

1250

PROBLEM - PRESENT RARE EARTH MAGNETS HAVE TOO HIGH A TEMPERATURE COEFFICIENT OF REVERSIBLE MAGNETIZATION FOR USE IN ACCELEROMETERS/GYROSCOPES NEEDED IN MISSILE AND MINI-RPV SYSTEMS AND IN SOME NEW MILLIMETER WAVE TRAVELING WAVE TUBES BEING DESIGNED.

SOLUTION - DEVELOP USA MANUFACTURING CAPABILITY FOR SAMARIUM-TWO-COBALT-SEVENTEEN-BASED MAGNETS WITH GADOLINIUM, DYSPROSIUM OR ERBIUM AND TRANSITION METAL SUBSTITUENTS WHICH YIELD ZERO TEMPERATURE COEFFICIENT MATERIALS WITH HIGH ENERGY PRODUCTS.

COMPONENT -- COMPONENTS

(CONTINUED)

(5130) TITLE - FERRITE DEVICES FOR MILLIMETER APPLICATIONS

600

PROBLEM - FERRITE DEVICES FOR 35 TO 94 GH FREQUENCIES ARE DIFFICULT TO FABRICATE AND ARE LIMITED IN THEIR PERFORMANCE. REPRODUCIBLE, HIGH PERFORMANCE CHARACTERISTICS ARE DIFFICULT TO ACHIEVE DUE TO SMALL SIZE COMPONENTS AT THESE FREQUENCIES.

SOLUTION - USING NEW DESIGN AND FABRICATION PROCEDURES, RELIABLE FERRITE PHASE SHIFTERS FOR PHASED ARRAY ANTENNAS AND CIRCULATORS WILL BE PRODUCED.

COMPONENT --- MISCELLANEOUS

(5017) TITLE - NON-HERMETIC HYBRID MICROCIRCUITS

1000

PROBLEM - SEALED CHIP TAPE CARRIER TECHNIQUES OFFER LOW COST ASSEMBLY AND ENVIRONMENTAL PROTECTION OF INTEGRATED CIRCUIT CHIPS ON HYBRID MICROCIRCUITS. SIMILAR TREATMENT OF DISCRETE TRANSISTOR AND DIODE CHIPS IS NOT ECONOMICALLY FEASIBLE.

SOLUTION - ESTABLISH PRODUCTION TECHNIQUES FOR SEALING AND HANDLING DISCRETE SEMICONDUCTOR DEVICE CHIPS INCLUDING TESTING AND BONDING OF CHIPS TO HYBRID MICROCIRCUITS.

\*\*\*\*\*  
\* C A T E G O R Y \*  
\*-----\*  
\*INTEGRATED ELECTRONICS \*  
\*\*\*\*\*

COMPONENT -- CIRCUITRY

(3026) TITLE - HIGH PRESSURE OXIDE INTEGRATED CIRCUIT PROCESS

405

PROBLEM - CONVENTIONAL OXIDATION OF THICK SILICON DIOXIDE LAYERS REQUIRES EXCESSIVE TIME OR TEMPERATURE. FOR OXIDE-ISOLATED BIPOLAR CIRCUITS, 1200 DEGREES FOR OVER 12 HOURS IS REQUIRED. FOR MOS/SOS, THE TEMPERATURES ARE EXCESSIVE.

SOLUTION - ESTABLISH PRODUCTION TECHNIQUES FOR HIGH PRESSURE OXIDATION OF SILICON LAYERS. RAPID OXIDATION RATES OBTAINABLE PERMIT EITHER REDUCTION OF TIME REQUIRED TO ONE-FOURTH OR A TEMPERATURE DECREASE TO LESS THAN 900 DEGREES.

(5005) TITLE - SEALED CHIP TAPE CARRIER FOR HYBRID MICROCIRCUITS

500

PROBLEM - RUGGEDIZATION OF HYBRID MICROCIRCUITS IS REQUIRED FOR ARTILLERY AND AIRCRAFT DELIVERED SENSORS AND TRANSMITTERS. FOR LONGTERM RELIABILITY, HERMETIC ENCLOSURES ARE REQUIRED. THESE PACKAGES ARE DIFFICULT AND COSTLY TO RUGGEDIZE.

SOLUTION - ESTABLISH PDN TECHNIQUES AND FAC FOR LOW COST, HIGH RELIABILITY PACKAGING OF ALL INTEGRATED CIRCUIT CHIPS USED IN MILITARY HYBRID MICROCIRCUITS. SEALED CHIP TAPE ASSEMBLED DEVICES PROVIDE CHIP PACKAGES TO BE USED IN NON-HERMETIC PACKAGES.

COMPONENT -- CIRCUITRY

(CONTINUED)

(5034) TITLE - CHARGE COUPLED DEVICE SIGNAL PROCESSORS

700

PROBLEM - EXTENSIVE ENGINEERING WORK IS REQUIRED TO INCORPORATE ANY CCD PROCESSING DEVICE INTO A SYSTEM. ALL INTERFACE CIRCUITRY MUST BE ESPECIALLY DESIGNED AND ASSEMBLED. THERE ALSO EXISTS A VERY LIMITED SELECTION OF COMMERCIAL CCD DEVICES.

SOLUTION - ESTABLISH PRODUCTION TECHNIQUES FOR DESIGN AND FABRICATION OF INTEGRATED CIRCUITS CONTAINING IN ONE CHIP CCD DEVICES, ANALOG CIRCUITRY, AND DIGITAL CIRCUITRY TO PERFORM ALL UNIQUE INTERFACE FUNCTIONS.

(5035) TITLE - HIGH SPEED DIGITAL HYBRID MICROCIRCUITS

1000

PROBLEM - THE ADVENT OF HIGH SPEED DIGITAL ICS, RADAR, VHSIC ARE LEADING TO USE OF DIGITAL TECHNIQUES FOR FRONT END USE IN DIRECT SIGNAL PROCESSING REQUIRING PACONNECTS BETWEEN ARRAYS OF HIGH SPEED DIGITAL ICS ID HIGH FREQUENCY TRANSMISSION TECHNIQUES.

SOLUTION - ESTABLISH MANUFACTURING PROCESSES AND FACILITIES FOR NEW HYBRIDS MICROCIRCUIT HIGH SPEED PACKAGING TECHNOLOGIES WHICH ARE CAPABLE OF REPAIRING INTER WITH REQUIRED HIGH FREQUENCY TRANSMISSION.

(5074) TITLE - MONOLYTHIC K-BAND TRANSMITTER/RECEIVER

1000

PROBLEM - REDUCE TO PRODUCTION ENVIRONMENT RESULTS OF PRIOR R&D TO DEVELOP COMPLETE MICROWAVE TRANSMITTER AND RECEIVER ON A CHIP OF GALLIUM ARSENIDE. TIGHT CONTROL OF LITHOGRAPHIC, THERMAL, AND MATERIALS PROCESSES TO 2 PCT. OR BETTER REQD FOR COST/YIELD GOAL

SOLUTION - USE OF HIGH VOLUME AUTOMATED PROCESSES TO REPRODUCIBLY BATCH FABRICATE CIRCUITS ON ZINC-GALLIUM-ARSENIDE WAFERS. AUTOMATE TESTING AND ESTABLISH PACKAGING TECHNIQUES AMENABLE TO VOLUME PRODUCTION. COST AND YIELD GOALS TO BE BETTER THAN NOW POSSIBLE.

(5101) TITLE - FABRICATION PROCESS OF CCD CHIPS

500

PROBLEM - IMPROVEMENT OF FABRICATION PROCESS OF CHIPS WITH CCD'S AND PERIPHERAL CIRCUITRY TO OBTAIN BETTER YIELDS AND LOWER COST. NEEDED IMPROVEMENTS INCLUDE OXIDE INTEGRITY, PHOTOLITHOGRAPHY METHODS, DESIGN RULES AND UNIFORMITY OF SUBSTRATE DOPING DENSITY.

SOLUTION - INVESTIGATIONS TO BETTER UNDERSTAND THE NATURE OF THE MANUFACTURING PROBLEMS AND TO DETERMINE THE NECESSARY TECHNIQUES TO ACCOMPLISH THE SOLUTIONS.

COMPONENT -- CIRCUITRY

(CONTINUED)

(5105) TITLE - THERMO-ELECTRO-OPTIC IC PROCESSES

600

PROBLEM - TREATMENT OF IC WAFERS AT ELEVATED TEMPERATURE-TIME LEAVES RESIDUAL DIFFUSION AND MATERIALS DEFECTS THAT ARE INCOMPATIBLE WITH SUBMICRON DEVICE PERFORMANCE. HIGH SPEED-DENSITY IC DEVELOPMENT IS ADVERSELY IMPACTED.

SOLUTION - DEVELOP MFG METHOD USING LASER OR E-BEAMS TO PRECISELY CONTROL TRANSIENT THERMAL PROCESSES TO REDUCE TEMP. TIME PRODUCTS BY 6 TO 12 ORDERS WITH NEGLIGIBLE BULK HEATING AND TO IMPLEMENT NON-EQUALIBRIUM METALLURGY FOR HIGH SPEED HIGH DENSITY IC'S.

(5106) TITLE - LOW COST MONOLITHIC GA-AS MICROWAVE CIRCUITS

1000

PROBLEM - MONOLITHIC CIRCUITS PLACE VERY STRINGENT REQUIREMENTS ON PROCESS UNIFORMITY AND REPRODUCIBILITY. HIGH YIELD PROCESSES AT EACH STEP ARE MANDATORY FOR ACCEPTABLE OVERALL YIELD AND COST. IN PROCESS TESTING IS NEEDED TO COMPENSATE FOR NO TUNING.

SOLUTION - DEVELOP PROCESSES TO USE HIGH VOLUME LITHOGRAPHY. IMPROVE PROCESSING AT EACH STEP FOR 95 PCT YIELD. BATCH HANDLING TECHNIQUES FOR GALLIUM ARSENIDE WAFERS. CONTROL OF QUALITY AND THICKNESS OF DIELECTRIC LAYERS. AUTOMATED TESTING AT WAFER LEVEL.

(5118) TITLE - DATA AND COMMUNICATIONS SYNTHESIZER

700

PROBLEM - FREQUENCY SYNTHESIZERS ARE AN ESSENTIAL COMPONENT OF VIRTUALLY ALL MILITARY COM. AND DATA LINK EQUIPMENTS. PRESENT SYNTHESIZERS ARE TOO COSTLY, LARGE, AND REQUIRE EXCESSIVE POWER FOR BATTERY OPERATION.

SOLUTION - DEVELOP A SET OF CIRCUITS WHICH CAN BE CONFIGURED TO SATISFY A WIDE VARIETY OF REQUIREMENTS. THE CIRCUITS WILL BE FABRICATED USING AN ADVANCED LOW POWER TECHNOLOGY AND USED IN LARGE QUANTITIES TO ASSURE LOW COSTS.

(5119) TITLE - XRAY LITHOGRAPHIC PRODUCTION TECHNIQUES FOR VHSIC

600

PROBLEM - VHSIC R AND D PROGRAMS WILL DEVELOP PROCESS FOR SUBMICRON HIGH SPEED SIGNAL PROCESSORS. POOR YIELD AND LACK OF PRODUCTION TYPE EQUIPMENT RESULTS IN VERY HIGH COST AND LOW RELIABILITY.

SOLUTION - DEVELOP EQUIPMENT AND PROCESSES TO IMPLEMENT VHSIC'S ON THE PRODUCTION LINE. INSTITUTE PROCESS CONTROLS TO IMPROVE YIELD. DEVELOP SCREENING AND PRODUCTION TECHNIQUES TO ENHANCE RELIABILITY.

(5120) TITLE - LOW-COST SAPPHIRE SUBSTRATES FOR CMOS CIRCUITS

700

PROBLEM - SOS IC SUBSTRATES MADE FROM SAPPHIRE BOULES ARE COSTLY AND IN LIMITED SUPPLY DUE TO SUBSTRATE PREP. OPERATIONS AND LOW PRODUCTION CAPABILITY. SOS IC'S ARE NEEDED FOR HIGH SPEED LOW POWER USE BUT CANNOT BE MADE IN QUANTITY WITHOUT LOW COST SUBSTRATES.

SOLUTION - DEVELOP PRODUCTION METHODS (LOW COST HIGH THROUGHPUT) FOR SUBSTRATES MADE FROM SAPPHIRE RIBBON.

COMPONENT -- CIRCUITRY

(CONTINUED)

(5121) TITLE - OPTIMIZED SUBSTRATES FOR HYBRID MICROCIRCUITS

750

PROBLEM - EVOLVING HIGH DENSITY HYBRIDS, HIGH SPEED HYBRIDS, + HIGH WATTAGE HYBRIDS PRESENT GREATER REQUIREMENTS FOR SUBSTRATES, DIMENSIONAL STABILITY THERMAL CONDUCTIVITY ELECTRICAL PERFORMANCE MANUFACTURABILITY AND COST.

SOLUTION - OPTIMIZE TWO MAJOR FORMS OF SUBSTRATES-INSULATED METAL AND ORGANIC SUBSTRATES. ESTABLISH MAJOR PRODUCIBILITY YIELD AND PERFORMANCE PARAMETERS, IDENTIFY OPTIMUM METAL SUBSTRATE BASES AND INSULATION AND OPTIMUM REINFORCING FIBERS AND RESIN BLENTERS.

(5129) TITLE - HIGH RELIABILITY VHSIC PROCESSES

700

PROBLEM - SUBMICRON VHSICs FOR HIGH SPEED SIGNAL PROCESSORS ARE SUBJECT TO EARLY FAILURE DUE TO EXCESSIVE ELECTRICAL STRESSES ON CHIP DIELECTRICS. R + D DESIGNS RESULT IN LOW YIELD AND HIGH COST.

SOLUTION - DEVELOP PRODUCTION PROCESSES FOR HIGH QUALITY GATE DIELECTRICS TO SUSTAIN REQUIRED HIGH FIELD STRESS. DEVELOP ALTERNATE DEVICE FABRICATION SEQUENCES TO REDUCE PROCESS INDUCED DEGRADATION IN DEVICE PERFORMANCES.

(5905) TITLE - LOW COST MONOLITHIC GALLIUM ARSENIDE MW INTEG CKTS

1179

PROBLEM - SIZE WEIGHT COST CONSTRAINTS LIMIT APPLICATION OF MICROWAVE ICS FOR MANY SYSTEMS APPLICATIONS. DRAMATIC REDUCTIONS PARTICULARLY COST ARE POTENTIALLY AVAILABLE ALONG WITH ORDER OF MAGNITUDE RELIABILITY IMPROVEMENT.

SOLUTION - ESTABLISH PRODUCTION CONTROLS FOR BATCH FABRICATION OF GALLIUM ARSENIDE MONOLITHIC CIRCUIT FUNCTIONS DRAW ON PRIOR R+D AND MMT EFFORTS IN E-BEAM, ION IMPLANT, AND VAPOR EPI TO FULLY AUTOMATE PRODUCTION OF AMPLIFIER AND RECEIVER FUNCTIONS.

(5909) TITLE - PRODUCTION TECHNIQUES FOR SI MW PWR TRANSISTORS

863

PROBLEM - AS THE CONCENTRATION OF INTEGRATED CIRCUITS INCREASES THE HEAT DENSITY IS REACHING THE POINT WHERE IT WILL DESTROY THE SEMICONDUCTOR DEVICES.

SOLUTION - REPLACE THE PRESENT PACKAGING DEVICES WITH UNITS HAVING A HIGH PERCENTAGE OF DIAMOND MATERIAL SO AS TO ACHIEVE A GREATER THERMAL TRANSMISSION.

COMPONENT -- FUZES

(3510) TITLE - TRANSDUCER PROCESS TECHNOLOGY FOR MW DELAY LINES

509

PROBLEM - THE PARAMETERS FOR DESCRIBING THE ACTUAL PROCESSES REQUIRED FOR HIGH-QUALITY TRANSDUCERS HAVE NOT BEEN DOCUMENTED. THIS RESULTS IN PRODUCTION HALTS AND LOW YIELD.

SOLUTION - DOCUMENT THE MATERIALS, PROCESSES, CONTROLS AND TECHNIQUES NECESSARY TO FABRICATE HIGH-QUALITY THIN FILM PIEZOELECTRIC TRANSDUCERS. THE PARAMETERS WILL BE INCREMENTALLY SHIFTED SO THAT A NON-CRITICAL STABLE PLATEAU REGION IS DEFINED.

MMT FIVE YEAR PLAN  
RCS DRCMT 126

FUNDING (\$0000)

PRIOR 80 81 82 83 84

COMPONENT -- MEMORY

(5094) TITLE - 8 K BIT MNOS BORAM

80

PROBLEM - PRESENT 2K BIT MEMORY CHIPS CANNOT STORE ADEQUATE DATA, AN 8K BIT CHIP HAS BEEN DEVELOPED IN R+D AND NEEDS TO BE PACKAGED AND PRODUCTION ENGINEERED

SOLUTION - ESTABLISH A PRODUCTION BASE FOR BUILDING MEMORY MODULES CONSISTING OF HYBRID CIRCUITS WITH SIXTEEN 8K BIT CHIPS.

(5104) TITLE - MILITARY MEMORY MODULES

750

PROBLEM - MILITARY SYSTEMS REQUIRE FUNCTIONAL MEMORY BLOCKS OF MEGABIT SIZE, CONSISTING OF INTERCONNECTED 16 KBIT MEMORY CHIPS PLUS DRIVER CIRCUITRY. CUSTOM ASSEMBLY AND DESIGN OF CARDS OR HYBRIDS IMPOSES EXCESSIVE COST AND RELIABILITY RISKS.

SOLUTION - ESTABLISH DESIGN AND METHODS FOR PRODUCTION OF LOW COST MULTIPURPOSE MEGABIT MEMORY MODULE. REDUCE COSTS AND FACILITATE BY DESIGN FOR TESTABILITY.

(5128) TITLE - COST EFFECTIVE MILITARY MEMORIES

800

PROBLEM - MILITARY ENVIRONMENTAL CONSTRAINTS CAUSE LOW SCREENING YIELDS AND HIGH COSTS IN HIGH DENSITY MILITARY MEMORY CHIPS, FORCING INCREASED USE OF NON-MILITARIZED PARTS WITH INHERENT RISKS FOR SYSTEMS RELIABILITY.

SOLUTION - YIELD IN MILITARY MEMORY PRODUCTION WILL BE IMPROVED SIGNIFICANTLY BY DESIGNING REDUNDANCY INTO CIRCUITRY AND INTERCONNECTING WORKING SECTIONS AFTER TEST. PROGRAM WILL DEVELOP TECHNIQUES FOR ADAPTIVE DESIGN AND CONNECTING OF REDUNDANT SUBSECTIONS.

\*\*\*\*\*  
\* C A T E G O R Y \*  
\*-----\*  
\*LASER \*  
\*\*\*\*\*

COMPONENT --- GENERAL

(3031) TITLE - 10.6 MICRON CO2 LASERS

27 523

PROBLEM - LASERS CONSTRUCTED IN UNIT QUANTITIES ARE EXPENSIVE AND VARY IN SPECIFICATIONS. PRESENT RANGE FINDER LASERS HAVE REDUCED ALL WEATHER CAPABILITIES AND ARE INEFFECTIVE AGAINST COUNTERMEASURE SHOKES.

SOLUTION - ESTABLISH LARGE SCALE PRODUCTION OF LASER COMPONENTS INCLUDING MIRRORS, ELECTRODES, AND LASER ENVELOPES TO REDUCE COSTS, DEVELOP UNITS THAT ARE RESISTANT TO THE SHOCK AND VIBRATION OF A TANK ENVIRONMENT.

FUNDING (\$000)

PRIOR 80 81 82 83 84  
-----

COMPONENT -- GENERAL

(CONTINUED)

(5124) TITLE - 20 WATT COHERENT CO2 LASER SOURCE

500

PROBLEM - NO PROBLEM GIVEN.

SOLUTION - DEVELOP MANUFACTURING TECHNIQUES FOR A 20 WATT LASER WITH A HIGH DEGREE OF SHORT TERM STABILITY FOR COHERENT DETECTION APPLICATION, INCLUDING IR RADAR.

COMPONENT -- MATERIALS

(5122) TITLE - QUATERNARY INJECTION LASERS

800

PROBLEM - NO PROBLEM GIVEN.

SOLUTION - DEVELOP PRODUCTION CAPABILITY FOR INJECTION LASERS FROM VAPOR PHASE EPITAXY FABRICATION METHOD FOR USE IN FIBER-OPTIC COMMUNICATION DEVICES AND EYE- SAFE TRAINING DEVICES.

COMPONENT -- MODULES

(5114) TITLE - MINI LASER TRANSMITTER MODULE

621

PROBLEM - PRESENT LASER TRANSMITTER MODULES FOR MINI LASER SYSTEMS MUST BE ASSEMBLED IN A LAB ENVIRONMENT FROM MANY DISCRETE E-O COMPONENTS AND ARE NOT DESIGNED FOR PRODUCTION

SOLUTION - DEVELOP PRODUCTION METHODS FOR MANUFACTURE AND ASSEMBLY OF MINITURE E-O COMPONENTS USING IC NETWORKS, COMBINED HYBRID UNSTABLE RESONATOR COMPONENTS AND OTHER MFR TECHNIQUES TO FABRICATE AND ASSEMBLE IN A PRODUCTION ENVIRONMENT.

(5123) TITLE - CONFIGURATION CONTROL- 0-A COMMON MODULES

1000

PROBLEM - NO PROBLEM GIVEN.

SOLUTION - DEVELOP PRODUCTION MANUFACTURING METHODS FOR CONFIGURATION CONTROL OF COMMON MODULES FOR A VARIETY OF 0-A SYSTEMS.

\*\*\*\*\*  
\* CATEGORY \*  
\*-----\*  
\*OPTICS \*  
\*\*\*\*\*

MMT FIVE YEAR PLAN  
RCS DRCMT 126

FUNDING (\$0000)

PRIOR 80 81 82 83 84

COMPONENT -- MISCELLANEOUS

(5046) TITLE - NON-LINEAR GAIN MCP'S FOR 3RD GEN. IMAGE INTENSIF. 792

PROBLEM - 3RD GEN TUBES REQUIRE NON-LINEAR GAIN MCP'S TO SUPPRESS BRIGHT HORIZON SKY OR OTHER BRIGHT IMAGES WHILE PROVIDING FULL GAIN IN DARK SCENE AREAS. PRESENT MANUF. METHODS FOR MCP ONLY PRODUCE MCP WITH LINEAR GAIN IN THE NORMAL OPERATING RANGE.

SOLUTION - ESTABLISH A NEW HIGH VOLUME MANUFACTURING PROCESS CONTROL TO ACCURATELY CONTROL NON-LINEAR GAIN CHARACTERISTICS OF THE MCP WHILE MAINTAINING ALL PARAMETERS SUCH AS LOW NOISE, BLEMISHES, FIXED PATTERN NOISE AND ION BARRIER PROTECTION.

(5061) TITLE - MULTI-SPECTRAL COATINGS 750

PROBLEM - DOUBLE BAND PASS (1.06 AND 8-14 MICRON) MULTI-LAYER COATINGS MUST BE PRODUCED ON VARIOUS OPTICAL MATERIALS. THESE COATINGS MUST MEET MIL. STANDARDS FOR HARDNESS WHICH IS A FUNCTION OF THE PROCESS.

SOLUTION - STRICT PROCESS CONTROLS MUST BE ESTABLISHED. MINIMUM TIME BETWEEN LAYER DEPOSITION MUST BE ACHIEVED AND PRODUCTION TECHNIQUES MUST BE DEVELOPED.

COMPONENT -- NIGHT VISION 600

(5065) TITLE - LOW COST CURVED CHANNEL MCP'S

PROBLEM - CURVED CHANNEL MCP'S PREVENT ION FEEDBACK TO THE PHOTOCATHODES, THEREBY ELIMINATING THE NEED FOR AN ION BARRIER FILM. CURVED CHANNEL MCP'S HAVE ONLY BEEN MADE WITH CRUDE AND EXPENSIVE LAB TECHNIQUES. LOW COST, HIGH VOLUME METHODS ARE NEEDED FOR MANUF

SOLUTION - ESTABLISH MANUF. METHODS FOR LOW COST FABRICATION.

COMPONENT -- WINDOWS/LENSES 518

(9845) TITLE - COMPUTER-AIDED FLIR ASPHERIC LENS FABRICATION 333

PROBLEM - ASPHERIC LENSES REQUIRED BY FLIR SENSORS HAVE SEVERE WEIGHT AND SIZE LIMITATIONS AND ARE DIFFICULT TO MFG. BECAUSE OF THE REPETITIVE PROCESS OF SURFACE SHAPING.

SOLUTION - PROVIDE MANUFACTURING METHODS FOR PRODUCING ASPHERICAL FLIR LENSES USING A SINGLE POINT DIAMOND TURNING LATHE INTEGRATED WITH COMPUTER CONTROLS AND LASER INTERFEROMETRIC FEEDBACK OF CUTTING TOOL POSITION.

\*\*\*\*\*  
\* C A T E G O R Y \*  
\*-----\*  
\*PASSIVE COMPONENTS\*  
\*\*\*\*\*

COMPONENT -- MISCELLANEOUS

(5109) TITLE - ULTRAWIDE BANDWIDTH SAW DELAY LINES

1004

PROBLEM - BROADBAND SAW DELAY LINES ARE REQUIRED FOR SIGNAL STORAGE DEVICE BANDWIDTH IS FIXED BY NEED TO STORE SIGNALS FOR A TEN MICROSECOND DURATION FOR SIGNALS RANGING OVER 500 MHZ BAND. DEVICE INSERTION LOSS AND MULTIPLE TRANSMIT REFLECTIONS MUST BE MINIMAL

SOLUTION - ESTABLISH PRODUCTION CAPABILITY FOR SAW DELAY LINES OPERATING AT 1GHZ USING IDENTICAL BROADBAND, NON-PERIODIC INTERDIGITAL TRANSDUCERS ON LITHIUM NIOBATE SUBSTRATES. HIGH RESOLUTION PHOTOLITHOGRAPHIC FABRICATION WILL USE DIRECT PROJECTION PRINTING.

(9552) TITLE - THICK FILM CONDUCTIVE NETWORKS

500

PROBLEM - THICK FILM CONDUCTIVE NETWORKS USED IN HYBRID MICROCIRCUITS UTILIZE GOLD OR PALLADIUM. THESE NOBLE METALS ARE EXPENSIVE AND CONTRIBUTE SIGNIFICANTLY TO THE PRICE OF THE NETWORK.

SOLUTION - ESTABLISH PRODUCTION TECHNIQUES FOR PREPARING, HANDLING AND PROCESSING OF A NON-NOBLE METAL CONDUCTIVE COMPOSITION FOR FABRICATING HYBRID MICROCIRCUITS.

\*\*\*\*\*  
\* C A T E G O R Y \*  
\*-----\*  
\*POWER SOURCES \*  
\*\*\*\*\*

COMPONENT -- INFRARED/UV

(3012) TITLE - IR SOURCES FOR AN/ALQ-144

350

PROBLEM - PRESENT INFRARED SOURCE FOR THE AN/ALQ-144 DOES NOT EMIT ENOUGH RADIATION IN BAND NO. 4.

SOLUTION - ESTABLISH PDN TECHNIQUES FOR FABRICATING BORON NITRIDE HEATED SOURCES AND PROCESSING, SEALING SOURCES IN INFRARED TRANSMISSIVE ENVELOPES RESULTING IN A SOURCE OF RADIATION CAPABLE OF SATISFYING ALL FOUR BANDS WITH NO INCREASE IN ELECTRICAL POWER.

COMPONENT -- MISCELLANEOUS

(5032) TITLE - MM RADAR MODULATOR FOR MINI-RPV AND TUBES

650

PROBLEM - MM RADAR MOD CAPABLE OF SURVIVING A RUGGED ENVIRONMENT WITH HIGH RELIABILITY REQUIRES COMPONENTS OF NO COMM INT. NEW SWITCH DEVELOPMENTS. PULSE SHARPENING TECHNIQUES, PULSE CHARGING, AND NANOSECOND PULSE TRANSFORMER MUST BE COMBINED INTO ONE UNIT.

SOLUTION - FABRICATE IN QUANTITY MM RADAR MODULATOR UTILIZING RECENT COMPONENT IMPROVEMENTS TO MEET MILITARY REQUIREMENTS WITH THE BEST EFFICIENCY, RELIABILITY, COST, WEIGHT POSSIBLE.

FUNDING (\$000)

PRIOR 80 81 82 83 84  
-----

COMPONENT -- TRANSFORMER

(9563) TITLE - MINIATURE HIGH VOLTAGE POWER SUPPLY FOR IMAGE INTENSIFIERS 535

PROBLEM - PRESENT IMAGE INTENSIFIER POWER SUPPLIES DO NOT MEET 3RD GEN. SHAPE AND SIZE REQUIREMENTS.

SOLUTION - DEVELOP NEW PROCESSES AND TECHNIQUES FOUND ON R AND D CONTRACTS.

\*\*\*\*\*  
\* C A T E G O R Y \*  
\*-----\*  
\*SOLID STATE \*  
\*\*\*\*\*

COMPONENT -- DIODES/RECTIFIERS

(3010) TITLE - MILLIMETER-WAVE SOURCES FOR 60 AND 94 GHZ 892

PROBLEM - TO ESTABLISH A MANUFACTURING CAPABILITY FOR PRODUCTION OF IMPATT DIODES WHICH ARE UNIFORM ENOUGH TO BE FIELD REPLACEABLE IN ARMY SYSTEMS.

SOLUTION - ESTABLISH TECHNIQUES AND PROCESSES CAPABLE OF PRODUCING SILICON DOUBLE DRIFT IMPATT SOURCES. PRECISE AND RIGOROUS COMPUTER CONTROL OF ALL MATERIAL IS REQUIRED.

(3011) TITLE - MILLIMETER-WAVE INDIUM PHOSPHIDE GUNN DEVICES 1179

PROBLEM - INADEQUATE CONTROL OF EPI MATERIAL AND DEVICE PROCESSING STEPS REQUIRING CLOSE TOLERANCES FOR EFFICIENT MM OPERATION RESULTS IN LOW YIELD POOR UNIFORMITY AND HIGH UNIT COST FOR MILLIMETER-WAVE INDIUM PHOSPHIDE GUNN DEVICES.

SOLUTION - ENG IN EPITAXIAL MATERIAL PREPARATION, INJECTION-LIMITED CONTACT FORMATION, INTEGRAL HEAT SINK TECHNOLOGY AND PACKAGING WILL BE PERFORMED TO ESTABLISH MANF TECHNIQUES AND CONTROLS RESULTING IN A DEVICE COST REDUCTION OF MORE THAN TEN TO ONE.

(5041) TITLE - MILLIMETER WAVE MIXERS AND ARRAYS 1152

PROBLEM - LOW NOISE RUGGEDIZED REPRODUCIBLE MIXERS ARE NEEDED FOR RECEIVERS FOR RADAR ELECTRONIC-WARFARE TERMINAL HOMING AND MISSILE GUIDANCE.

SOLUTION - IN SITU CONSTRUCTION AND DESIGN WILL PROVIDE REPRODUCIBLE UNITS AT FREQUENCIES FROM 40 GHZ UP TO 600 GHZ. NEW TECHNOLOGIES TO BE DEVELOPED INCLUDE EBEM LITHOGRAPHY AND COMPUTER CONTROL OF MATERIALS GROWTH.

COMPONENT -- DIODES/RECTIFIERS

(CONTINUED)

(5148) TITLE - MMT 94 GHZ IMPATT DIODE SOURCES

1150

PROBLEM - NEW DOD ELECTRONIC SYSTEMS OPERATING AT 94 GHZ REQUIRE HIGH PERFORMANCE LOW COST IMPATT DOUBLE DRIFT DIODE SOURCES. ADVANCED IMPATT DIODE FABRICATION TECHNIQUES CURRENTLY UNDER DEVELOPMENT WILL BE IMPLEMENTED.

SOLUTION - ADVANCED FABRICATION TECHNIQUES INCLUDING MOLECULAR BEAM EPITAXY, DIE CASTING AND STAMPING RESONATOR FABRICATION AND BEAM LEAD TECHNIQUES TO ELIMINATE WIRE BONDING PACKAGING. WILL BE UTILIZED. HIGHER YIELD, LOWER COST AND A SECOND VENDOR WILL RESULT.

COMPONENT -- SWITCHES

(5031) TITLE - LONG LIFE SPARK GAP

1200

PROBLEM - LASER PULSERS FOR RANGEFINDERS AND DESIGNATORS ARE LIMITED BY SPARK GAP LIFETIMES AND NOT THE LASER. POOR SPARK GAP LIFETIMES DEGRADES SYSTEM RELIABILITY AND INCREASES COST.

SOLUTION - IMPROVE MANUFACTURING TECHNIQUES TO INCORPORATE LOW SPUTTER ELECTRODES INTO SPARK GAPS. IMPROVE TESTING PROCEDURES DURING MANUFACTURE TO ELIMINATE SPARK GAPS WITH POTENTIALLY POOR LIFE TIMES.

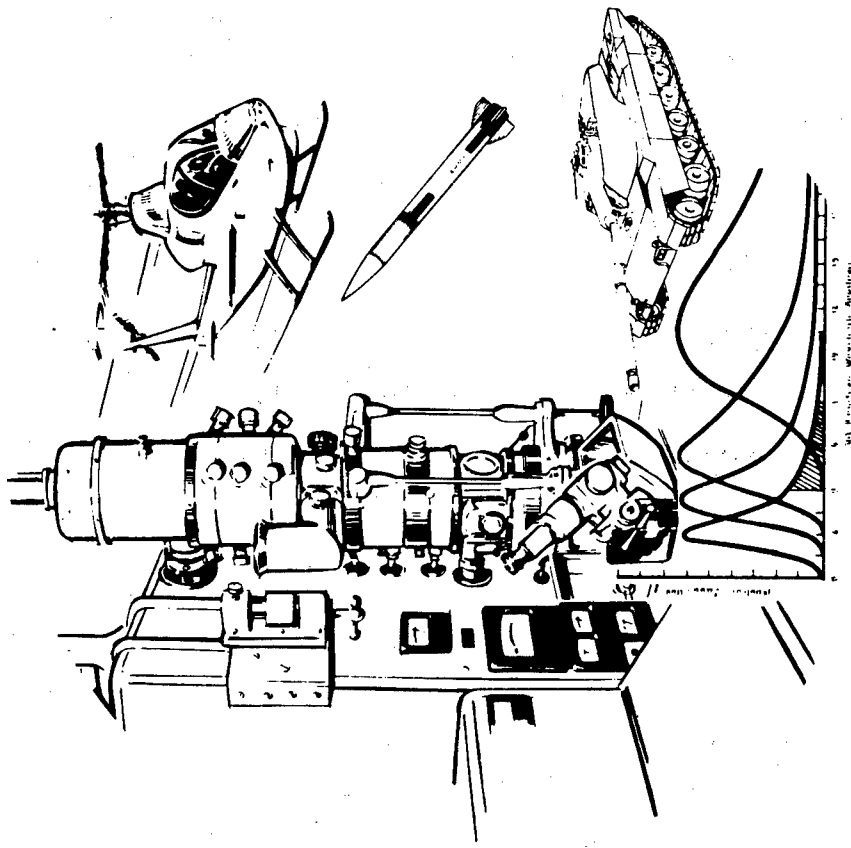

# MATERIALS & MECHANICS RESEARCH CENTER

<u>CATEGORY</u>	<u>PAGE</u>
General -----	156
Testing -----	156

## US ARMY MATERIALS AND MECHANICS RESEARCH CENTER

(AMMRC)

The Army Materials and Mechanics Research Center (AMMRC) is designated the DARCOM Lead Laboratory for Materials Testing Technology. In this role, AMMRC is responsible for management and direction of the DARCOM materials testing technology activities and formulation of the Materials Testing Technology (MTT) Program. This program formulation is accomplished by identifying and defining materials testing problem areas in response to system requirements of the DARCOM R&D and Readiness Commands and Project Managers utilizing materials testing technology. The Lead Laboratory mission also encompasses the advising and assisting of the major subordinate commands and Project Managers in the utilization of Materials Testing Technology in order to assure a smooth transition from the developmental to the production phases of the life cycle. Concurrent with the above responsibilities is the furnishing of technical assistance in the application of methods and techniques in solving material problems in connection with procured items.

The MTT Program has shown a steady growth over the last several years, from 2.5 million dollars in FY 73 to 4.5 million dollars in FY 79. This growth has been largely due to the increased participation in the Program by DARCOM Project Managers, as well as increased attention to the Program by DARCOM Quality Assurance managers. Another increasing trend within the MMT Program has also been the directing of more and more testing related projects to the MTT Program. Specific areas of effort are as follows:

### a. Automated Testing

One of the primary needs in NDT and in inspection in general is to remove the decision-making from the inspector where possible. In FY 80 and beyond efforts will be intensively directed toward providing engineering prototype systems utilizing automated decision-making. These include automated radiographic and ultrasonic techniques, optical/laser techniques, and computerized chemical analysis. The ultimate goal in all automated testing systems is the essential feedback to the total system for automated process control.

### b. Predictive Failure

The need for diagnostic measurement techniques for anticipation of catastrophic failure and for the measurement of remaining life, both in operating equipment and in units being overhauled and rebuilt, presents a tremendous opportunity for cost savings and reliability improvement. A principal thrust has come from the loss of single engine aircraft due to malfunction. In essence, the field of diagnostics and in-situ measurements adjunct to non-destructive testing represents the real time use of NDT techniques with analysis and decision elements built in.

c. Materials

As the newer materials are utilized in major weapon systems, it is imperative that new and/or improved inspection techniques be available to measure characteristics or parameters to assure adequate and reliable performance. Of particular interest in the next five years are composites, elastomers, plastics, and ceramics, with continuing interest in metals and energetics (explosives, pyrotechnics, and propellants).

d. Techniques

Specifically covered in the objectives of the MTT Program is the investigation of specific physical principles which can potentially offer significant improvement in sensitivity, cost, portability, or speed, and combination of these. The development and application of techniques, such as ultrasonics, infrared, holography, spectroscopy, chromatography, etc., can significantly improve DARCOM materiel and offer substantial improvement in process control.

DARCOM-AMMRC  
 C O M M A N D F U N D I N G S U M M A R Y  
 (THOUSANDS)

CATEGORY -----	FY80 ----	FY81 ----	FY82 ----	FY83 ----	FY84 ----
GENERAL	710	765	830	850	850
TESTING	4414	5000	5000	5000	5000
TOTAL	5124	5765	5830	5850	5850

\*\*\*\*\*  
 \* C A T E G O R Y \*  
 \*-----\*  
 \*GENERAL\*  
 \*\*\*\*\*

MMT FIVE YEAR PLAN  
 RCS DRCMT 126

FUNDING (\$000)

PRIOR	80	81	82	83	84
-----					
3174	460	515	580	600	600

COMPONENT -- MISCELLANEOUS

(5052) TITLE - ARMY ENGINEERING DESIGN HANDBOOK FOR PRODUCTION SUPPORT

PROBLEM - TECHNICAL SCIENTIFIC AND ENGINEERING DATA IS CONTINALLY BEING GENERATED WITHIN THE ARMY AND NEEDS TO BE COLLECTED IN APPROPRIATE DOCUMENTS.

SOLUTION - INITIATE REVISE AND UPDATE DATA USED IN PRODUCTION OF MILITARY HARDWARE AND EQUIPMENT.

(6390) TITLE - PROGRAM IMPLEMENTATION AND INFORMATION TRANSFER

PROBLEM - THE SUCCESS OF THE MMT PROGRAM IS VERY DEPENDENT ON WHETHER THE RESULTS OF MMT WORK GET IMPLEMENTED. THIS IN TURN IS DEPENDENT ON WHETHER INFORMATION CONCERNING THE MMT TECHNOLOGY IS MADE AVAILABLE AND USED BY CONCERNED PARTIES.

SOLUTION - INSURE THAT THE MMT RESULTS ARE DOCUMENTED AND GIVEN WIDE DISTRIBUTION SO AS TO ENCOURAGE IMPLEMENTATION.

\*\*\*\*\*  
 \* C A T E G O R Y \*  
 \*-----\*  
 \*TESTING\*  
 \*\*\*\*\*

COMPONENT -- CHEMICAL

(6350) TITLE - MATERIALS TESTING TECHNOLOGY (MTT)

PROBLEM - CURRENT LABORATORY METHODS FOR CHEMICAL TESTING ARE SPECIALIZED AND EXPENSIVE. REAL TIME TESTING TECHNIQUES ARE NEEDED TO CONTROL CHEMICAL PROCESSING.

SOLUTION - ADAPT QUICK RESPONSE CHEMICAL TESTING EQUIPMENT TO AUTOMATE THE CONTROL OF CHEMICAL PROCESSES.

COMPONENT -- MECHANICAL

(6350) TITLE - MATERIALS TESTING TECHNOLOGY (MTT)

PROBLEM - METHODS OF MECHANICAL TESTING ARE BASICALLY TIME CONSUMING. LABORATORY TYPE OPERATIONS. THE TESTING IS OFTEN ULTIMATE AND THEREFORE DESTRUCTIVE OR IT TENDS TO INTRODUCE RESIDUAL STRESS/STRAIN IN THE TESTED ITEMS.

SOLUTION - ESTABLISH IMPROVED REAL-TIME INSPECTION TECHNIQUES TO REDUCE PRODUCTION BOTTLENECKS ASSOCIATED WITH MECHANICAL TESTING. ALSO, THE OPTIMUM TESTING CRITERIA WILL BE ESTABLISHED WHEN NECESSARY.

142	250	250	250	250	250
4700	982	1115	1115	1115	1115

4469	944	1060	1060	1060	1060
------	-----	------	------	------	------

MMT FIVE YEAR PLAN  
RCS DRCMT 126

FUNDING (\$000)

PRIOR 80 81 82 83 84  
-----

COMPONENT -- NON-DESTRUCTIVE

(6350) TITLE - MATERIALS TESTING TECHNOLOGY (MTT)

11910 2488 2825 2825 2825 2825

PROBLEM - DESTRUCTIVE AND CERTAIN CONVENTIONAL NON-DESTRUCTIVE TESTING TECHNIQUES ARE RESPECTIVELY UNSUITED AND INADEQUATE OR HARD TO BE ADAPTED TO ON-LINE PRODUCTION TESTING USAGE.

SOLUTION - DETERMINE FEASIBILITY OF ADAPTING LAB-PROVEN NDT METHODS OR MODIFY THE EXISTING TEST PROCEDURES FOR ON-LINE PRODUCTION QUALITY ASSURANCE TESTING.

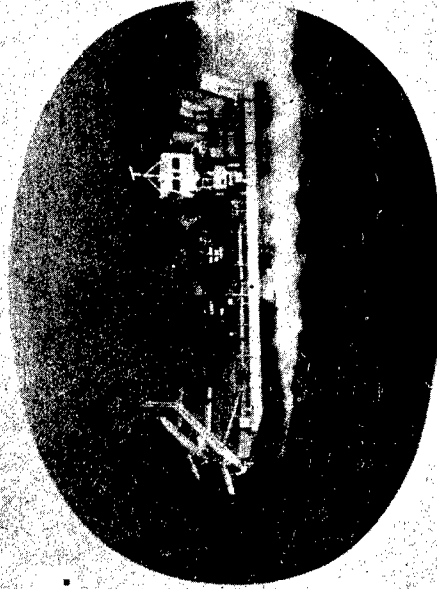
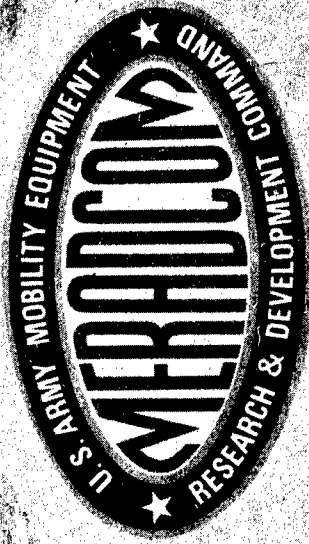
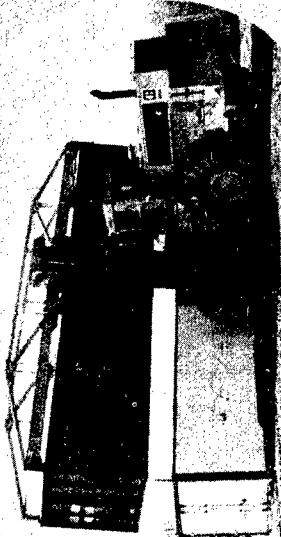

Fort Belvoir, Va.

<u>CATEGORY</u>	<u>PAGE</u>
Bridging -----	164
General -----	164
Land Mines -----	165
Power Sources -----	166

US ARMY MOBILITY EQUIPMENT RESEARCH AND DEVELOPMENT COMMAND

(MERADCOM)

MERADCOM, located at Fort Belvoir, VA, conducts a widely diversified program to improve the Army's combat readiness in four major areas: barrier and counterbarrier systems; countersurveillance systems; energy and environmental systems; and supply distribution and construction equipment systems.

Procurements for items under MERADCOM's cognizance are placed with the private sector, and much of MERADCOM's MMT effort is accomplished by the private sector.

To address the problem of increased system acquisition costs, MERADCOM has identified major problem areas where improved manufacturing technology is needed. Major problem areas confronting MERADCOM include:

a. Limitations of High Temperature Super Alloy Components of Gas Turbine Engines. A limiting factor in the life and performance of gas turbines is the ability of the components to withstand the abrasive and corrosive environment at peak operating temperatures. Super alloy metals utilizing strategic materials are limited to 1750 $\frac{1}{2}$ F operating temperature and are subject to catastrophic failure when subjected to high dust concentrations or corrosive atmosphere such as salt. Thermal efficiency can be improved by increasing peak cycle temperature currently limited by maximum operating temperature of materials of the burner, turbine inlet nozzle, and turbine wheel. The most critical component for damage due to wear and corrosion is the turbine nozzle. Materials are needed which have increased operating temperature limits and improved resistance to corrosion and abrasive wear at a reasonable cost. Projects addressing this problem area are 3717 and 3719.

b. Military Quality Power Conditioners. The development of lightweight, military quality power conditioners is, to a large extent, dependent upon the availability of reliable, lightweight, compact electronic components. The power stages of these power conditioners employ an important class of these components - power semiconducting devices. Currently available versions of these power semiconducting devices in the required ratings often are too heavy and bulky to be conveniently used in the power stages of military power conditioners under development. Also, in some instances, reliability of currently available devices is not adequate for military power conditioners. Recognizing the limitations of today's power semiconducting devices, MERADCOM has been developing reliable, lightweight, compact power semiconducting devices. A project attacking this area is 3772.

c. Providing Military Bridges at Moderate Cost, Which Have High Mobility and High Emplacement Speeds While Retaining The Ability to Withstand the Abusive Treatment Inherent in the Battlefield Environment.

High strength, low density composite materials in both organic and/or metallic matrix appear to offer great promise for solutions to this problem. Increased production of high strength fiber materials has reduced materials cost. Techniques for the fabrication and installation of these materials into usable bridge components is the area in which large cost reductions are possible. The reduction of presently used labor intensive methods, through the application of automated processes, will reduce component costs. Initial design in these materials offer improved performance due to the flexibility possible in material configuration. Projects directed at this problem area are 3746 and 3786.

MERADCOM

C O M M A N D F U N D I N G S U M M A R Y  
(THOUSANDS)

CATEGORY -----	FY80 ----	FY81 ----	FY82 ----	FY83 ----	FY84 ----
BRIDGING	0	563	0	1100	700
GENERAL	806	224	0	350	0
LAND MINES	0	0	834	0	0
POWER SOURCES	461	293	0	476	1177
TOTAL	1267	1080	834	1926	1877

MMT FIVE YEAR PLAN  
RCS DRCHT 126

\*\*\*\*\*  
\* C A T E G O R Y \*  
\*-----\*  
\*BRIDGING \*  
\*\*\*\*\*

FUNDING (\$000)

PRIOR 80 81 82 83 84  
-----

COMPONENT -- REINFORCEMENT

454

(3745) TITLE - ALUMINUM SKIN-GRAPHITE/EPOXY SANDWICH BRIDGE REINF

PROBLEM - FORMULATION OF PROCEDURES TO MASS PRODUCE ALUMINUM SKIN-GRAPHITE EPOXY SANDWICH MATERIAL FOR BRIDGE STRUCTURAL MEMBERS.

SOLUTION - SANDWICH ALUMINUM SKIN-GRAPHITE EPOXY ALUMINUM SKIN LAMINATE SHOWS PROMISE OF BEING A STRUCTURE THAT WOULD SATISFY OUR NEEDS IF IT CAN BE ECONOMICALLY MASS-PRODUCED USING ROOM CURING ADHESIVES.

109

(3759) TITLE - KEVLAR CABLE REINFORCEMENT FOR MILITARY BRIDGES

PROBLEM - TO PROVIDE LIGHT WEIGHT REINFORCEMENT TENSION MEMBER HAVING HIGH TENSILE PROPERTIES AND MODULUS.

SOLUTION - DETERMINE IF KEVLAR MATERIAL CAN BE PRODUCED ON A PRODUCTION BASIS AND MAINTAIN THE HIGH PHYSICAL PROPERTIES REQUIRED IN A REINFORCING MEMBER.

400

COMPONENT -- STRUCTURAL MEMBERS

(3746) TITLE - METAL MATRIX COMPOSITE MATERIAL

PROBLEM - CONNECTION OF COMPOSITE MATERIAL IS DIFFICULT IN LINEAR PLANAR COMPONENTS. MECHANICAL CONNECTIONS ARE EXPENSIVE IN BOTH DESIGN AND MATERIAL.

300

SOLUTION - IMBED HIGH MODULUS FIBER MATERIAL IN DUCTILE METAL WHICH CAN BE WORKED AND CONNECTED WITH STANDARD METHODS.

(3761) TITLE - DIMPLE PLATE WEB FOR BRIDGES

PROBLEM - HOW TO STABILIZE THIN SHEETS OF ALUMINUM TO CARRY HIGH SHEAR STRESSES WITHOUT BUCKLING.

400

SOLUTION - CONTROLLED SPACING OF DRAWN DIMPLES OF PLATES AND SPOTWELDED TWO PLATES TOGETHER AT BOTTOM OF DIMPLES TO FORM A SANDWICH PLATE.

(3786) TITLE - MULTI HOLLOW SHEAR WEB MODULE

PROBLEM - TO PROVIDE A LIGHT WEIGHT SINGLE PIECE WEB MEMBER WHICH CAN BE EASILY ATTACHED TO TOP AND BOTTOM CHORD MEMBERS.

700

SOLUTION - WIND THE WEB MODULE ON A LARGE INFLATED CYLINDRICAL MANDREL USING GRAPHITE EPOXY. AFTER WINDING IN UNCURED STATE DEFLATE MANDREL AND FORCE WOUND MEMBER INTO MOLD HAVING DESIRED WEB SHAPE AND CURE.

\*\*\*\*\*  
\* C A T E G O R Y \*  
\*-----\*  
\*GENERAL \*  
\*\*\*\*\*

COMPONENT -- MISCELLANEOUS

(3708) TITLE - COLLAPSIBLE FABRIC TANKS - CIRCULAR SEAMLESS WEAVE 100

PROBLEM - TO IMPROVE THE RELIABILITY AND ENDURANCE OF FABRIC PILLOW TANKS BY ELIMINATING THE LONGITUDINAL SEAMS WHICH ARE VULCANIZED TOGETHER. THESE SEAMS ARE THE MOST LIKELY CAUSE OF CATASTROPHIC FAILURE.

SOLUTION - DEVELOP A MANUFACTURING METHOD OF WEAVING A CIRCULAR SEAMLESS TUBE.

(3709) TITLE - CONTINUOUS LENGTH FUEL HOSE 245 179 89

PROBLEM - PRESENT FUEL RESISTANT CONTINUOUS LENGTH HOSE IS MANDREL FABRICATION. FIFTY OR A HUNDRED FEET LENGTH OF HOSE IS FIRST MANDREL MADE AND THEN SECTIONS ARE SPLICED TOGETHER FOR THE DESIRED LENGTH. SPLICING IS LABOR INTENSIVE.

SOLUTION - EXTRUDE DESIRED LENGTHS OF HOSE WITHOUT SPLICES. FIRE HOSE IS PRODUCED BY THIS METHOD, WHICH IS ALSO APPLICABLE TO FUEL HOSE. NON-SPLICED, EXTRUDED, CONTINUOUS HOSE WILL BE MORE RELIABLE AND LESS EXPENSIVE THAN PRESENT SPLICED HOSE.

(3718) TITLE - DETERMINE PRODUCTION METHODS AIR CYCLE CIRCULATOR 350

PROBLEM - TECHNICAL INNOVATION HAS PRODUCED AN AIR CYCLE COMPRESSOR-EXPANDER. THE FABRICATION TECHNIQUES AND MATERIALS OF CONSTRUCTION USER TO PRODUCE PROOF OF CONCEPT HARDWARE WILL BE UNECONOMICAL FOR FULL SCALE PRODUCTION.

SOLUTION - DEVELOP NEW MANUFACTURING METHODS TO MACHINE ELLIPTICAL CAM TRACKS INTO END PLATES OF COMPRESSOR-EXPANDER.

(3747) TITLE - LACV-30, SKIRT AND FINGER COMPONENTS 191 135

PROBLEM - FABRICATION OF SKIRT, FINGERS AND CONES IS CURRENTLY HIGHLY LABOR INTENSIVE, LEADING TO HIGH COMPONENT REPLACEMENT COSTS.

SOLUTION - DEVELOP MECHANIZED/AUTOMATED FABRICATION TECHNIQUES TO REDUCE MANUFACTURING COSTS.

(3749) TITLE - HYDRAULIC ROTOR ACTUATORS 750 145

PROBLEM - ROTARY ACTUATOR MODELS HAVE NEVER BEEN PRODUCED ON A QUANTITY BASIS.

SOLUTION - REDUCE DIFFICULTIES THAT ARE ANTICIPATED IN OBTAINING THE REQUIRED CLOSE TOLERANCES AND MICRO-FINISHES WITH STANDARD PRODUCTION TOOLS.

\*\*\*\*\*  
\* C A T E G O R Y \*  
\*-----\*  
\*LAND MINES \*  
\*\*\*\*\*

COMPONENT -- NEUTRALIZERS

(3796) TITLE - COMBAT VEHICLE DEGAUSSING

834

PROBLEM - PRESENT DESIGN AND FABRICATION TECHNIQUES FOR VEHICLES RESULT IN A SIGNIFICANT MAGNETIC SIGNATURE. THIS MAGNETIC SIGNATURE CAN BE USED TO FUZE LAND MINES TO ATTACK THE VEHICLE UNDERCARRIAGE.

SOLUTION - CONSTRUCT A PILOT DEGAUSSING SYSTEM THAT WILL ALLOW DEVELOPMENT OF A DEGAUSSING TECHNIQUE FOR US ARMORED VEHICLES.

\*\*\*\*\*  
\* C A T E G O R Y \*  
\*-----\*  
\*POWER SOURCES \*  
\*\*\*\*\*

COMPONENT -- MISCELLANEOUS

(3605) TITLE - TRANSCALENT (HIGH POWER) TRANSISTOR

503 25

PROBLEM - CURRENTLY AVAILABLE SOLID STATE POWER DEVICES OF REQUIRED RATINGS AND THEIR HEATSINKS OFTEN ARE TOO HEAVY AND BULKY TO BE CONVENIENTLY USED IN COMPACT LIGHTWEIGHT POWER CONDITIONERS.

SOLUTION - SEVELOP MANUFACTURING PROCESSES FROM R&D DESIGNS FOR COMPACT LIGHT WEIGHT TRANSCALENT DEVICES. THESE DEVICES WITH INTEGRAL HEAT PIPES DO NOT REQUIRE EXTERNALLY MOUNTED HEATSINKS.

(3772) TITLE - INTEGRATED POWER SWITCH

370 459

PROBLEM - THE HIGH POWER SWITCHING CAPABILITY REQUIRES IMPROVED COOLING OF THE POWER STAGE. THIS REQUIRES MECHANICAL AND ELECTRICAL CONSIDERATIONS.

SOLUTION - METHODS MUST BE DEVELOPED TO PRODUCE AND ATTACH HEAT PIPES FOR COOLING DURING QUANTITY PRODUCTION. RELATED ELECTRICAL AND MECHANICAL CHANGES MUST ALSO BE DEVELOPED FOR QUANTITY PRODUCTION.

(3785) TITLE - SENSING AND CONTROL MODULE

106 393

PROBLEM - TRANSFORMERLESS INVERTERS UTILIZE MANY DISCRETE SEMICONDUCTORS INTERCONNECTED TO INTEGRATE CIRCUITS IN LIEU OF TRANSFORMERS BUT RESULTING HEAT DISSIPATION REQUIRES A BULKY PACKAGE WITH REDUCED RELIABILITY.

SOLUTION - DEVELOP MANUFACTURING PROCESS FOR MODULES INCORPORATING INTEGRATED CIRCUITS AND OTHER ELECTRONIC COMPONENTS WITH A LARGE SCALE INTEGRATED CIRCUIT REPLACING DISCRETE DEVICES. MODULES ARE TO INCLUDE SATISFACTORY COOLING DEVICE SUCH AS A HEAT PIPE.

FUNDING (\$000)

PRIOR 80 81 82 83 84  
-----

COMPONENT -- TURBINES

(3717) TITLE - HIGH TEMPERATURE NOZZLE FOR 10KW POWER UNIT

343 436 293

PROBLEM - SUPER ALLOY METALS USED IN HOT COMPONENTS OF GAS TURBINES ARE LIMITED IN OPERATING TEMPERATURE AND ARE SUBJECT TO PREMATURE FAILURE IN DUSTY OR CORROSIVE ATMOSPHERE. ALLOY METALS ARE STRATEGIC MATERIALS AND ARE COSTLY TO MANUFACTURE.

SOLUTION - DETERMINE METHODS AND TECHNIQUES TO REDUCE THE COST OF MANUFACTURING HIGH TEMPERATURE CERAMIC MATERIALS WHICH HAVE BEEN FOUND TO POSSESS HIGH TEMPERATURE RESISTANCE TO DUST ABRASION AND SALT CORROSION. MATERIALS WILL CONTAIN NO STRATEGIC ELEMENTS.

(3719) TITLE - HEAT EXCHANGER FOR 10-30 KW REGEN CYCLE GAS TURBINE

325

PROBLEM - GAS TURBINE REGENERATORS AND RECUPERATORS SIGNIFICANTLY INCREASE UNIT COST, SIZE AND WEIGHT WHICH OFFSETS BENEFIT OF SIGNIFICANTLY REDUCED FUEL CONSUMPTION.

SOLUTION - DETERMINE METHODS AND TECHNIQUES TO REDUCE FABRICATION COSTS FOR ADVANCED HEAT EXCHANGER CORE AND HEADER MATERIALS SUITABLE FOR OPERATING IN ADVANCED GAS TURBINE HIGH TEMPERATURE ENVIRONMENT.

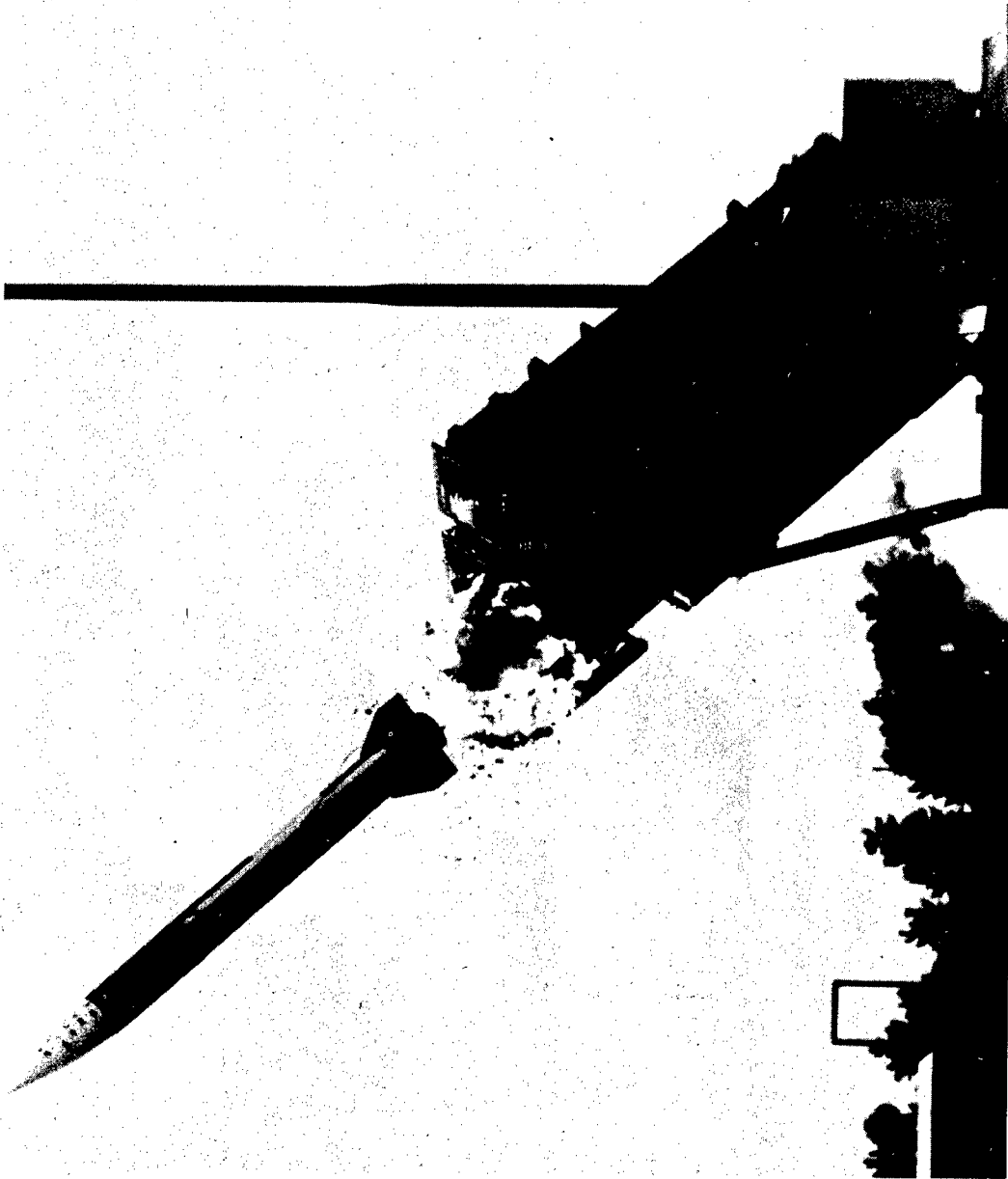

MISSILE COMMAND  
(MICOM)

<u>CONTAINERS</u>	<u>PAGE</u>
Containers/Launchers -----	173
Control System -----	173
Ground Support Equipment -----	174
Guidance System -----	176
Missile Structure -----	187
Propulsion System -----	191
Test Equipment -----	196

## US ARMY MISSILE COMMAND

### (MICOM)

The US Army Missile Command is located at Redstone Arsenal, AL, and is responsible for research, development, and acquisition of missile systems for the Army. Facilities include flight test ranges, laboratories, and a simulation center.

Major systems managed by special project offices include STINGER (Shoulder-Fired Air Defense Guided Missile), US ROLAND (All-Weather Air Defense Missile System), MLRS (Multiple Launched Rocket System), Viper (Short-Range Anti-Tank Weapon), HELLFIRE (Helicopter-Carried Air-To-Ground Missile), PERSHING (400-Mile Range Air-to-Ground Missile) and the 2.75 Inch Air-to-Ground Rocket. MICOM is also the Army's center for laser research and manages efforts to apply lasers in missile guidance and as weapons.

The major thrusts in MICOM's MMT program is in guidance systems. A large amount of this effort is planned for work on gyros, printed circuits, and seekers. Improvements in the gyro can be made by addressing proposals in new machining methods and assembly techniques. Efforts in the electronics area include projects on plated-through holes, thin foils, wave soldering, and cleanliness criteria. The seeker area includes work on infrared optics, radio frequency, and laser optics. Other work planned on guidance systems include projects for windows and radomes, optics, and hybrid circuits.

Another major thrust area is missile structures, which includes projects for airframes using metal, plastic, or composites. Efforts for composite airframes will address filament winding, inner shell forming and missile substructures. New joining, machining, and forming technologies will be investigated and applied.

Proposals in the area of test equipment include work on electrical, x-ray, neutron and hydraulic equipment. Calibration efforts include infrared testing of PC boards, digital fault isolation, and automatic circuit tuning.

MICOM  
 C O M M A N D F U N D I N G S U M M A R Y  
 (THOUSANDS)

CATEGORY -----	FY80 ----	FY81 ----	FY82 ----	FY83 ----	FY84 ----
CONTAINERS/LAUNCHERS	0	0	0	723	898
CONTROL SYSTEM	400	5250	2550	0	350
GROUND SUPPORT EQUIPMENT	635	0	0	1550	1575
GUIDANCE SYSTEM	3725	4080	4750	7584	6082
MISSILE STRUCTURE	745	810	1650	3543	3516
PROPULSION SYSTEM	680	3295	4573	2540	3263
TEST EQUIPMENT	1137	1886	1658	1402	2340
TOTAL	7322	15321	15181	17342	18024

\*\*\*\*\*  
 \* C A T E G O R Y \*  
 \*-----\*  
 \*CONTAINERS/LAUNCHERS \*  
 \*\*\*\*\*

MMT FIVE YEAR PLAN  
 RCS DRCMT 126

FUNDING (\$000)

PRIOR 80 81 82 83 84

COMPONENT -- LAUNCHERS

(1027) TITLE - LOW COST SMALL ROCKET CONTAINER/LAUNCHER PODS

PROBLEM - CURRENT LAUNCH PODS ARE EXPENSIVE AND REQUIRE REUSE IN ORDER TO MAINTAIN COST PER ROUND AT AN ACCEPTABLE LEVEL.

SOLUTION - LOW COST PLASTICS WILL BE APPLIED TO THE STRUCTURE. COMMERCIAL GRADE PLASTICS SUCH AS ABS, PVC, AND FOAMS IN MOLDED AND FORMED SHAPES WILL BE CONSIDERED. LONG TERM SERVICE ENVIRONMENT WILL BE EVALUATED BY ACCELERATED AGING AND CREEP TESTING.

300

(1029) TITLE - FORGING AND EXTRUSION METHODS FOR POWDER AL ALLOYS CT90 CT91

PROBLEM - HIGH STRENGTH LIGHTWEIGHT STRUCTURES HAVE TYPICALLY RESORTED TO THE USE OF MATERIALS WITH VERY HIGH YIELD STRENGTHS AT THE SACRIFICE OF TOUGHNESS, FRACTURE TOUGHNESS, STRESS CORROSION CRACKING RESISTANCE AND FORMABILITY.

SOLUTION - RECENT DEVELOPMENTS IN POWDER METALLURGY ALUMINIUM ALLOYS FOR EXTRUSION AND FORGING HAVE MADE AVAILABLE TWO ALLOYS WITH A COMBINATION OF PROPERTIES THAT HAVE SIGNIFICANTLY ADVANCED THE STRUCTURAL CAPABILITIES OF HI STR/WT MATL'S AT REASONABLE COST.

385 248

(1045) TITLE - RAPID CURE FOAM-IN-PLACE

PROBLEM - PRODUCTION PROCESSES FOR FOAM-IN-PLACE MATERIALS ARE NOT CONDUCTIVE FOR HIGH RATE PRODUCTION OF LARGE STRUCTURES. PROBLEMS INCLUDE NON-UNIFORM DENSITY, SLOW FOAMING, AND VOIDS IN CONSTRICTED PARTS.

SOLUTION - IMPROVE MFG METHODS REQUIRED TO FABRICATE LARGE, COMPLEX STRUCTURES. THIS WILL INCLUDE OPTIMIZATION OF FOAM PLACEMENT METHODS, TOOLING CONCEPTS, AND MATERIALS SYSTEMS TO SUPPORT HIGH RATE, LOW COST PRODUCTION.

350

\*\*\*\*\*  
 \* C A T E G O R Y \*  
 \*-----\*  
 \*CONTROL SYSTEM \*  
 \*\*\*\*\*

COMPONENT -- CIRCUITRY

(1063) TITLE - SEMIADDITIVE REEL TO REEL FLEX PRINT PROCESS

PROBLEM - CONVENTIONAL BATCH PROCESSING OF PRINTED WIRING BOARDS IS LABOR INTENSIVE. HAND LABOR IS BOTH COSTLY AND SUBJECT TO ERRORS WHICH ADDS REJECT LOSSES TO LABOR COSTS.

350 350

SOLUTION - A REEL TO REEL MFG PROCESS FOR PWB'S WILL PRODUCE COMPLETE PWB'S FROM REELS OF CLAD STOCK IN A SEQUENTIAL SET OF OPERATIONS. THE OUTPUT CIRCUITS WILL BE FLAT CABLE OR FLEXIBLE CIRCUITRY.

MMT FIVE YEAR PLAN  
RCS DRGMT 126

FUNDING (\$0000)

PRIOR 80 81 82 83 84  
-----

COMPONENT -- CIRCUITRY

(CONTINUED)

(1071) TITLE - HYBRID INTEGRATED CAD AND MANUFACTURING (HICADAM)

100 1000

PROBLEM - HYBRID CIRCUIT DESIGN AND MANUFACTURE IS LABOR INTENSIVE. THE CAD DATA BASE HAS NOT BEEN EXTENDED TO MANUFACTURING PROCESS CONTROL.

SOLUTION - ANALYZE FUNCTIONAL FLOW AND MANUFACTURING PROCESS CONTROLS AND MODIFY THE DESIGN DATA BASE TO MAKE IT CAPABLE OF DEFINING FUNCTIONS, INPUT, OUTPUT, CONTROLS AND INTERFACES. USE ICAM METHODOLOGY TO DEVELOP SYSTEM ARCHITECTURE.

(1075) TITLE - ELECTRONICS COMPUTER AIDED MANUFACTURING (ECAM)

300 2700 1000

PROBLEM - ALTHOUGH INTEGRATED CIRCUITS, HYBRID CIRCUITS, PRINTED CIRCUITS AND CABLES ARE DESIGNED ON A COMPUTER, THERE IS LITTLE COMPUTERIZED CONTROL OF PROCESSES USED TO PRODUCE THESE ITEMS. A MASTER PLAN IS NEEDED TO DEFINE THE AREA AND REQUIREMENTS.

SOLUTION - DEVELOP A DOD MASTER PLAN FOR COMPUTER-AIDED DESIGN AND MFG OF ELECTRONIC SYSTEMS. USE AIR FORCE'S ICAM AND NASA'S IPAD PROGRAMS TO DEFINE CAD/CAM AND ELECTRONIC TECHNOLOGIES TO MAKE INTEGRATED CIRCUITS, HYBRID CIRCUITS, PRINTED CIRCUITS, AND CABLES.

(3108) TITLE - MISSILE/ROCKET DISPENSING SYSTEM

350

PROBLEM - DISPENSING UNITS ARE FABRICATED, ASSEMBLED, AND TESTED BY HAND.

SOLUTION - ESTABLISH AUTOMATED AND SEMI-AUTOMATED SYSTEM FOR PRODUCING THE DISPENSING DEVICE

COMPONENT -- INTEGRATED ELECTRONICS

(1072) TITLE - MULTIPLE HIGH RELIABILITY/LOW VOLUME LSI MFG

1200 1200

PROBLEM - LOW VOLUME PURCHASE OF LSI CHIPS DOES NOT LEND ITSELF TO CIRCUIT VARIATIONS. LARGER THAN NEEDED NUMBERS OF CHIPS MUST BE ORDERED TO GET THE PRODUCER'S ATTENTION. A LOW-VOLUME CHIP CAPABILITY IS NEEDED.

SOLUTION - ANALYZE ALL LSI RESEARCH RESULTS AND SINGLE OUT NEW PROCESSING TECHNIQUES. ESTABLISH A MILITARY CAPTIVE DESIGN AND PRODUCTION LINE. DEVELOP SOFTWARE FOR CAD OF LSI CIRCUITS. PRODUCE VARIATIONS OF SEVERAL CIRCUIT FAMILIES.

\*\*\*\*\*  
\* C A T E G O R Y \*  
\*-----\*  
\*GROUND SUPPORT EQUIPMENT\*  
\*\*\*\*\*

COMPONENT -- CIRCUITRY

(1056) TITLE - MILLIMETER WAVE OSCILLATORS FOR MONOPULSE RECEIVERS

500 500

PROBLEM - DEVELOPMENT OF A 140 GIGHERTZ GUIDANCE SYSTEM IS HAMPERED BY HIGH COST AND LOW EFFICIENCY OF THE MACHINED WAVEGUIDE VARACTOR MULTIPLIERS. GUNN OSCILLATORS, THE ONLY PRACTICAL ONE FOR INPUT, HAS BORDERLINE POWER LEVELS.

SOLUTION - USE THE SEMI-ADDITIVE PWB MFG PROCESS TO ELECTROPLATE SILVER ON LOW LOSS SUBSTRATES TO FORM 1) A LOW FREQUENCY INPUT BAND PASS FILTER MATCHING THE GUNN, 2) A NON LINEAR VARACTOR ELEMENT, AND 3) A HIGH FREQUENCY OUTPUT BAND PASS AT 140 GIGHERTZ.

(3113) TITLE - STD. OF COMPUTER BASED DESIGN FOR PCB AND ELECTRONIC EQUIP.

250 200

PROBLEM - THE GOVERNMENT IS PRESENTLY UNABLE TO UTILIZE CONTRACTOR DESIGN DATA FOR FABRICATION AND TEST OF PRINTED CIRCUIT BOARDS

SOLUTION - DEVELOP A STANDARD SYSTEM LANGUAGE FOR PROCESSING DESIGN DATA TO BE USED BY A SECOND SOURCE OR BREAKOUT CONTRACTORS.

(3214) TITLE - INJECTION MOLDING ELECT. CONNECTORS + CABLES

400

PROBLEM - STRAIN RELIEF POTTING AND MOLDING, AND ENVIRONMENTAL SEALING OF ELECTRICAL CABLE AND OF CONTACTOR ASSEMBLIES IS COSTLY.

SOLUTION - THE CABLES WILL BE INJECTION MOLDED IN A 4 STEP PROGRAM. INJECTION MOLDING WITH A COST ANALYSIS WILL BE MADE. DESIGN, FAB & MOLDING GUIDELINES WILL BE DEFINED. QUALIFICATION METHODS WILL BE DEFINED. CURRENT HARDWARE WILL BE PROCESSED AND EVALUATED.

(3217) TITLE - AUTO PROD OF TRAVELING WAVE TUBES

335

PROBLEM - THE SAM-D TWT IS THE MOST EXPENSIVE COMPONENT IN THE GUIDANCE SYSTEM AND IS A SIGNIFICANT SYSTEM COST DRIVER. A FUNDAMENTAL CHANGE OF CONCEPT IN THE MANUFACTURING PROCESS IS REQUIRED.

SOLUTION - DEVELOP AUTOMATED PROCEDURES TO PERFORM FABRICATION PROCESSING AND TEST OPERATION THAT PRESENTLY REQUIRES EXTENSIVE LABOR.

(3233) TITLE - COMPUTERIZED INTEGRATED MANUFACTURING SUPPORT (CAM)

500

PROBLEM - MANUFACTURING SYSTEMS MUST BECOME MORE PRODUCTIVE, FLEXIBLE AND PRECISE AND BETTER ABLE TO COPE WITH VARYING REQUIREMENTS.

SOLUTION - ESTABLISH A SYSTEM DESIGN RELATING INPUT, OUTPUTS, FORMATS, AND DATA TO MEET REQUIREMENTS OF THE TOTAL DESIGN TO USE PROGRESSION.

COMPONENT -- CIRCUITRY

(CONTINUED)

(3376) TITLE - TESTING ELECTRO-OPTICAL COMPONENTS AND SUBSYSTEMS 375 300

PROBLEM - MANUFACTURING TECHNOLOGY NECESSARY FOR PRODUCTION OF ELECTRO-OPTICAL SYSTEMS IS VERY LIMITED. LITTLE CORRELATION EXISTS BETWEEN COMPONENT SPECIFICATIONS AND THE PARAMETERS THAT IMPACT SYSTEM PERFORMANCE.

SOLUTION - ECONOMY OF PRODUCTION, TESTING METHODS, OR TECHNIQUES COULD BE DEVELOPED BY VALIDATING EXISTING SPECIFICATIONS OR REPLACING EXISTING ONES WITH SPECIFICATIONS THAT ARE BASED ON SYSTEM PERFORMANCE RATHER THAN COMPONENT PERFORMANCE.

COMPONENT -- GENERAL

(3238) TITLE - MANUFACTURING COST ANALYSIS (CAM) 175 150

PROBLEM - THERE IS A NEED TO DEFINE AND CONTROL ACQUISITION PROGRAM COST DURING CONTRACT DEFINITION AND DEVELOPMENTAL PHASES.

SOLUTION - STRUCTURE COMPUTER MODEL TO CALCULATE THE LABOR CONTENT OF A DESIGN CONCEPT IN STANDARD SETUP AND RUN TIME.

(3437) TITLE - RECOVERY/RECYCLING OF HEAVY METAL FROM SPENT PROCESSING SOLS 225 225

PROBLEM - THE PRESENT NATIONWIDE PRACTICE FOR THE DISPOSAL OF WASTE PRECIOUS METAL MATERIALS IS TREATMENT IN A CONVENTIONAL WASTE TREATMENT PLANT.

SOLUTION - DEVELOP ONE OR MORE SYSTEMS AND PROCESSES THAT WILL RECOVER THESE PRESENTLY DISCARDED MATERIALS IN A SALEABLE RE-USABLE FORM.

\*\*\*\*\*  
\* C A T E G O R Y \*  
\*-----\*  
\*GUIDANCE SYSTEM \*  
\*\*\*\*\*

COMPONENT -- ACCELEROMETERS

(1018) TITLE - IMPROVED MFG PROCESSES FOR DRY TUNED ACCELEROMETERS (CAM) 380

PROBLEM - THERE IS A NEED TO ESTABLISH MANUFACTURING METHODS NECESSARY TO INCREASE YIELD AND REDUCE COST OF DRY TUNED ACCELEROMETERS. THE PRESENT METHOD IS LABOR INTENSIVE AND PRONE TO ERROR.

SOLUTION - ELECTRO-DISCHARGE MACHINING CAN BE ADAPTED TO AUTOMATED MACHINING OF THE COMPLEX DRY FLEXURE SUPPORTS. THIS APPROACH WILL PROVIDE THE FLEXIBILITY TO OPTIMIZE THE SUPPORT DESIGN FOR QUANTITY PRODUCTION.

PRIOR 80 81 82 83 84

COMPONENT -- BATTERIES

(3281) TITLE - SILVER ZINC GUIDANCE BATTERIES (CAM)

250 250

PROBLEM - ANODE AND CATHODE MANUFACTURING FOR SILVER ZINC BATTERIES IS BASED ON TWENTY YEAR OLD TECHNIQUES. REQUIREMENTS CALL FOR IN LINE PRODUCTION AND ACCEPTANCE TESTS.

SOLUTION - DEVELOP A COMPUTER AIDED MANUFACTURING PROCESS FOR SILVER-ZINC BATTERIES WITH CONTROLLING SENSORS FOR ACCURATELY MEASURING MATERIALS AND ELECTROCHEMICAL COMBINATION.

COMPONENT -- HYBRIDS

(1059) TITLE - ELECTRICAL VERIFICATION AND BURN-IN FOR IN-PROCESS HYBR CHIP

400

PROBLEM - INSTALLATION OF BAD CHIPS IN HYBRID CIRCUITS IS A CONTINUING PROBLEM. CHIPS ARE TESTED BY PROBE CHECKING, AND WHEN POSSIBLE ARE REMOVED AND REPLACED. ACCEPTANCE PROCEDURES MUST INCLUDE A LOT ACCEPTANCE PROCEDURE IN ADDITION TO PROBING & VISUAL INSP.

SOLUTION - MODIFY TAPE LEAD CARRIER TO PREVENT INSTALLATION OF BAD CHIPS IN HYBRID CIRCUITS. DEVELOP THE PROCESS TO PROBE CHECK A CHIP AND TO REMOVE IT FROM HYBRID CIRCUIT PRODUCTION IF CHIP IS BAD. ADAPT PROCEDURES TO TEST EQUIPMENT AND BURN-IN EQUIPMENT.

(1066) TITLE - ADDITIVE SINGLE AND MULTILAYER HYBRID CIRCUITRY

250 250

PROBLEM - THICK FILM CIRCUITRY USES THE SCREEN AND FIRE PROCESS ON CERAMIC SUBSTRATES. A SEMIADDITIVE FINE-LINE PROCESS, ELECTROLESS COPPER PLATING, USED ON FIBERGLASS AND CERAMIC SUBSTRATES WILL PROVIDE BETTER FINE-LINE AND A COST REDUCTION.

SOLUTION - LAMINATE SURFACE CONDITIONS AND ELECTROLESS COPPER CATALYST STRENGTHS WILL BE INVESTIGATED. VARIATIONS IN PROCESSING PARAMETERS WILL BE EVALUATED. SOFTWARE TECHNIQUES FOR AUTOMATION OF MANUFACTURING PROCESSES WILL BE DEVELOPED.

(1091) TITLE - ELIM OF PRECIOUS METALS MICROCIRCUIT APPLICATIONS

725

PROBLEM - SUBSTITUTE MATERIALS ARE NEEDED IN PLACE OF PRECIOUS METALS IN HYBRID CIRCUITS. BUT NONNOBLE SUBSTITUTES ARE INHERENTLY REACTIVE DURING PROCESSING AND STORAGE AND CAN REDUCE RELIABILITY.

SOLUTION - REVIEW THICK FILM INK SYSTEMS. IDENTIFY REACTIVE COMPONENTS OF CONDUCTOR AND INSULATOR PASTES. DETERMINE HYBRID MATERIAL PROPERTIES AND INTERACTIVE BEHAVIOR. EVALUATE ADHESION, CONDUCTIVITY, BONDABILITY AND SOLDERABILITY. DEFINE PROCESS CONTROLS.

COMPONENT -- HYBRIDS

(CONTINUED)

(1092) TITLE - AUTOMATIC TESTING OF SUBSTRATES

250

PROBLEM - THICK FILM SUBSTRATES ARE HARD TO TEST BEFORE THE COMPONENTS ARE APPLIED FOR CONTINUITY. IF A BED OF NAILS OR PROBE IS USED IT COULD MAGE THE PADS OR CIRCUITRY. IF THE COMPONENTS ARE ATTACHED, THE SUBSTRATE COULD HAVE BEEN DEFECTIVE.

SOLUTION - DEVELOP AN ELECTRON BEAM SCANNER THAT WILL INSPECT A THICK FILM SUBSTRATE BY CHARGING EACH THICK FILM CONDUCTOR AND LOOK FOR OPENS AND SHORTS. A COMPUTER WILL DRIVE THE BEAM AND LOOK AT DETECTORS FOR BACKSCATTER. A LIBRARY OF DEFECTS WILL BE DEVELOP

(1095) TITLE - AUTOMATIC SEALING OF HYBRIDS

250

PROBLEM - SEALING OF SMALL METAL PACKAGES IS DONE BY HAND SOLDERING OR HAND-GUIDED ELECTRIC SEAM WELDING. BOTH REQUIRE AN OPERATOR.

SOLUTION - DEVELOP A COMPUTER DIRECTED SOLDERING TECHNIQUE OR APPLY COMPUTER CONTROL TO THE SEAM WELDER. SET UP MEANS TO LOCATE THE PACKAGE AND LID IN A FIXTURE, TO CHECK ALIGNMENT, CONTROL THE CLOSURE OPERATION, TEST THE SEAL WHILE STILL IN THE INERT ATMOSPHER

(3110) TITLE - HYBRID CIRCUIT ASSEMBLY UTILIZING AUTOMATED TECHNIQUES

650

PROBLEM - FILM HYBRID CIRCUITS ARE PRESENTLY MANUFACTURED IN A LABORATORY ATMOSPHERE BY ONLY A FEW PRODUCERS.

SOLUTION - CONVERT LABORATORY TECHNIQUES INTO PRODUCTION METHODS UTILIZING AUTOMATED COMMERCIAL EQUIPMENT

(3182) TITLE - PRODUCTION TOOLING TECHNIQUES FOR MODULAR ELECTRONICS

350

PROBLEM - VERY DENSE PACKAGING MAKES ASSEMBLY VERY COSTLY.

SOLUTION - THERE ARE NO FABRICATION TECHNIQUES FOR PLACING LEADLESS INVERTED DEVICES (LID'S) AND COMPONENT CHIPS DIRECTLY ONTO PRINTED CIRCUIT BOARDS.

(3435) TITLE - SIMPLIFICATION OF HIGH-POWER THICK FILM HYBRIDS

290

PROBLEM - THE PRESENT METHOD OF COOLING HIGH POWER HYBRID CIRCUITS INVOLVES A COMPLEX AND EXPENSIVE PROCEDURE USED ONLY ON LIMITED PRODUCTION ITEMS. USE OF A SINGLE BERYLLIA SUBSTRATE HAS BEEN DEMONSTRATED BUT NEEDS FURTHER DEVELOPMENT.

SOLUTION - A MANUFACTURING PROCESS WILL BE DEVELOPED TO SCREEN AND FIRE THICK FILM INKS ONTO BERYLLIA SURFACES. COMMERCIAL INKS WILL BE EVALUATED FOR COMPATIBILITY WITH BERYLLIA AND THE TOXICITY OF BERYLLIA WILL BE TAKEN INTO ACCOUNT.

COMPONENT -- HYBRIDS

(CONTINUED)

(3436) TITLE - DEVELOP CERAMIC CIRCUIT BOARDS AND LARGE AREA HYBRIDS 325 450

PROBLEM - ADVANCED WEAPONS SYSTEMS NOW REQUIRE GREATER COMPLEXITY AND PACKAGING DENSITY THAN CAN BE PRODUCED BY CONVENTIONAL HYBRID TECHNOLOGY WITH SUITABLE COST AND RELIABILITY TRADEOFFS.

SOLUTION - DEVELOP IMPROVED PROCESSES AND TECHNIQUES FOR FABRICATING RELIABLE, HIGH DENSITY HYBRID CIRCUITS.

(3439) TITLE - LOW COST HYBRID MICROELECTRONIC CIRCUITS 300

PROBLEM - DESIGN CRITERIA AND COMPONENT SELECTION AFFECT THE TOTAL HYBRID FABRICATION CYCLE TO AN EXTENT THAT CONSTANT MACHINE OPERATOR ATTENTION IS REQUIRED.

SOLUTION - DETERMINE THE COST DRIVERS OF HYBRID CIRCUIT FABRICATION AND TEST. DEFINE FINITE PROBLEMS TO ALLOW MORE ECONOMICAL METHODS FOR MACHINE OPERATIONS.

COMPONENT -- INTEGRATED ELECTRONICS

(1019) TITLE - CONVERSION OF SURPLUS PENTABORANE TO B10 507

PROBLEM - THE DIBORANE (B2) USED IN THE MANUFACTURE OF DECARBORANE (B10) IS A COST DRIVER.

SOLUTION - DEVELOP A PROCESS TO MIX GOVERNMENT OWNED PENTABORANE (B5) WITH B2 TO REDUCE THE COST OF THE PRODUCT B10.

(1024) TITLE - RADIO FREQUENCY STRIPLINE HYBRID COMPONENTS 745

PROBLEM - THE TREND IN STRIPLINE TECHNOLOGY IS TO INTEGRATE WITHIN THE STRIPLINE ELEMENT DISCRETE COMPONENTS BOTH ACTIVE AND PASSIVE. TWO PROBLEMS NEED RESOLUTION - (1) NEED FOR EXTREME DIMENSIONAL ACCURACY, (2) COMPENSATION VARIABLE DIELECTRIC THICKNESS.

SOLUTION - DEVELOP A PROGRAM TO ESTABLISH REQUIREMENTS, PROCESSES, QUALITY ASSURANCE, AND LIMITATIONS OF PLACEMENT, ASSEMBLY, AND INTERCONNECTION FOR INCORPORATING DISCRETE COMPONENTS INTEGRAL WITH RF STRIPLINE COMPONENTS.

(1031) TITLE - HIGH SPEED PLATING OF CARD EDGE CONTACTS. 600

PROBLEM - MASKING OF THE CONNECTOR IS AN EXPENSIVE PROCESS AND REQUIRES A CLEANING PROCESS TO REMOVE THE RESIDUE FROM THE TAPE. THE ADJACENT PLATING JUNCTION OF DISSIMILAR METALS REQUIRES STRICT CONTROLS TO PREVENT HAIRLINE CRACKS.

SOLUTION - DEVELOP HIGH SPEED PULSE PLATING OF THE CONTACTS. THIS WILL ELIMINATE THE REQUIREMENT FOR MASKING, CLEANING TO REMOVE THE MASKING RESIDUE AND REDUCE COST.

COMPONENT -- INTEGRATED ELECTRONICS (CONTINUED)

(1055) TITLE - REMOVE GOLD FROM COMPONENT LEADS

175

PROBLEM - GOLD PLATING, USED ON MOST ACTIVE DEVICE LEADS MUST BE REMOVED BY MANUAL DOUBLE SOLDER DIPPING PER MIL STANDARDS. THIS IS SLOW AND COSTLY BUT NECESSARY TO PREVENT GOLD EMBRITTELEMENT OF SOLDER JOINTS WHICH COULD RESULT IN PREMATURE FAILURE.

SOLUTION - DEVELOP AN AUTOMATED MACHINE FOR REMOVING GOLD FROM COMPONENT LEADS BY THE REQUIRED DOUBLE SOLDER DIP METHOD.

(1058) TITLE - SUBMINIATURE COMPONENT PACKAGING

350 400 400

PROBLEM - ULTRA HIGH DENSITY PWB'S ARE NEEDED AND CAN NOW BE MANUFACTURED WITH 5 MIL LINES AND 5 MIL SPACES. THIS ORDER OF BOARD DENSITY CANNOT BE FULLY UTILIZED WITH A SERIES OF CASES SUCH AS TO-CANS AND DIPS, SINCE THEIR LEAD SPACES REQUIRE TOO MUCH AREA.

SOLUTION - ADAPT THE HERMETICALLY SEALED (PASSIVATED) CHIP TO THE NEW ULTRA HIGH DENSITY PWB. HYBRID TYPE COMPONENTS WILL REQUIRE LITTLE MODIFICATION. ACTIVE DEVICES - TRANSISTORS AND INTEGRATED CIRCUITS - WILL REQUIRE PASSIVATION.

(1061) TITLE - STANDARDIZED MASKING TECHNIQUES FOR PWB ASSEMBLIES

250

PROBLEM - NO STANDARDIZED CONFORMAL MASKING TECHNIQUES ARE IN EXISTENCE THROUGHOUT INDUSTRY. MATERIALS AND TECHNIQUES ARE SELECTED BY PERSONNEL ACCORDING TO THEIR OWN JUDGEMENT PRIOR TO CONFORMAL COATING. DAMAGE RESULTS WHEN WRONG JUDGEMENT WAS USED.

SOLUTION - DEVELOP STANDARDIZED MASKING MATERIALS AND TECHNIQUES BASED UPON WHICH TYPE OF AREAS ON THE PWB ASSEMBLY ARE TO BE FREE OF CONFORMAL COATING. PARAMETERS SUCH AS TERMINAL GEOMETRY, HOLE PATTERNS, HEAT SINK ZONES WILL BE EVALUATED.

(1062) TITLE - PREVENTING BRITTLE COPPER CIRCUITRY

380

PROBLEM - BRITTLE CLADDING FOIL AND BRITTLE ELECTRODEPOSITED COPPER FOR PWB'S IS A PREVALENT PROBLEM. NO PROCEDURE EXISTS FOR THE EARLY DETECTION OF EMBRITTELEMENT IN COPPER ELECTRODEPOSITS.

SOLUTION - MEASURE THE DUCTILE-TO-BRITTLE TRANSITION IN COPPER DEPOSITS. THE MEASUREMENT OF BRITTLE TRANSITION PROVIDES A MEANS FOR THE EARLY DETECTION OF THE CHANGE FROM DUCTILE TO BRITTLE.

COMPONENT -- INTEGRATED ELECTRONICS (CONTINUED)

(1065) TITLE - PROD OF QUIET RADAR SIGNAL PROCESSORS USING VLSI TECHNOLOGY 250

PROBLEM - THE MAN TECH BASE TO PRODUCE RADAR SIGNAL PROCESSORS USING VHSI (VERY HIGH SPEED INTEGRATED CIRCUITS) DOES NOT EXIST. METHODS USING LSI (LARGE SCALE INTEGRATED) CHIPS ARE INADEQUATE. HOWEVER, SOME TECHNIQUES MAY BE TRANSLATABLE TO VLSI.

SOLUTION - THIS PROJECT WILL USE FOUR CHIPS DEVELOPED UNDER ANOTHER MMT PROGRAM TO ESTABLISH MANUFACTURING METHODS FOR THE QUIET RADAR SIGNAL PROCESSOR. PROJECT WILL REDUCE COST AND IMPROVE RELIABILITY AND MAINTAINABILITY.

(1090) TITLE - ION IMPLANTED THIN FILM TRANSISTORS 350

PROBLEM - PRESNET METHODS FOR MAKING THIN FILM TRANSISTORS HAVE LESS THAN OPTIMUM CONTROL OF GEOMETRY AND ELECTRICAL PROPERTIES. BUT ION IMPLANTATION MAY BE ADAPTABLE.

SOLUTION - APPLY ION IMPLANTATION TO MFG OF THIN FILM TRANSISTORS. IT IS DONE AT 300-400 DEGREE F AND WILL NOT DAMAGE THE SUBSTRATE FILM. WILL BE USED AS INERTIAL GRADE ACCELEROMETERS.

(1093) TITLE - PRODUCTION METHODS FOR A MILLIMETER MODULAR TRANSPONDER 650

PROBLEM - TRANSPONDERS NOW REQUIRE MUCH HAND FABRICATION LABOR AND ARE HIGH COST. THEY ARE USED ONLY ONCE. THEY MUST RECEIVE A GUIDANCE RADAR SIGNAL, DECODE IT, FORM A CODED REPLY AND TRANSMIT IT TO THE GUIDANCE RADAR. MUST WITHSTAND A HIGH-G ENVIRONMENT.

SOLUTION - REDUCE CONFIGURATION TO A FORM THAT MINIMIZES MFG COST. MODULARIZE TRANSPONDER BY FUNCTION ANTENNA MODULE, RECEIVER MODULE, DECODING MODULE, ENCODING MODULE, TRANSMITTER MODULE, POWER SUPPLY MODULE. BUILD MODULES TO FIT IN A FOUR INCH HI. USE LSI.

(1103) TITLE - STABLE MAT 1EM+MFR FOR MULTILAYER PRINTED WIRE BOARDS 425

PROBLEM - MATERIAL FAILURE AND INTERLAYER MIS-REGISTRATION IN MULTILAYER CIRCUIT BOARDS INCREASES WITH THINNER BASE LAMINATES. SPECIFICATIONS FOR RAW MATERIALS AND CONTROL ON LAMINATES THAT WILL REDUCE BOARD STRESSES INTRODUCED BY BONDING ARE REQUIRED.

SOLUTION - MILITARY SPECS COVERING PRINTED CIRCUIT BOARD STANDARDS, COPPER CLAD LAMINATES AND PRE-PRE+ MATERIAL WILL BE IMPROVED. CONTROL ON LAMINATES AND ON BOARD FABRICATION WILL BE MODIFIED TO ALLOW INCREASED BOARD YIELD AND RELIABILITY.

(3164) TITLE - COMPONENT SIDE PRINTED CIRCUIT BOARD SOLDERING 325

PROBLEM - THERE IS NO KNOWN METHOD FOR HOLDING COMPONENTS IN ALIGNMENT FOR MOUNTING.

SOLUTION - REFINE PROCESS FOR FOIL SIDE MOUNTING OF COMPONENTS TO ACCOMMODATE FLEXIBLE CIRCUITS.

COMPONENT -- INTEGRATED ELECTRONICS (CONTINUED)

250

(3184) TITLE - SCREEN PRINTING PROCESSES FOR PTH ON PLASTIC PCB'S

PROBLEM - SET UP AND RUN TIME FOR ELECTROLESS COPPER PLATED THRU HOLES (PTH) IS APPROXIMATELY 3.75 MIN PER BOARD WITHOUT INSPECTION OR MAINTENANCE.

SOLUTION - SCREEN PRINTING COULD ACCOMPLISH THE SAME JOB IN APPROXIMATELY .48 MIN PER BOARD. INVESTIGATE CURING CYCLE, SCREEN PREPARATION TIME, AND PASTE THEOLOGY FOR OPTIMUM FLOW THRU HOLES.

400 375

(3254) TITLE - SEMI-FLEXIBLE THIN FILM SEMICONDUCTORS

PROBLEM - PRESENT CIRCUIT BOARDS LACK THE PACKING DENSITY AND STRINGENT PACKAGING QUALITIES PROJECTED FOR FUTURE MISSILE ELECTRONIC SYSTEMS.

SOLUTION - DEVELOP MANUFACTURING PROCESS FOR PUTTING THIN FILM MICRO-CIRCUITS ON FLEXIBLE SUBSTRATES.

250 250

(3263) TITLE - MANF. TECH. FOR PWB UTILIZING LEADLESS COMPONENTS

PROBLEM - THE VOLUME, WEIGHT, QUANTITY, RELIABILITY AND COST OF PCB'S USING AXIAL LEADED COMPONENTS CAN BE SUBSTANTIALLY IMPROVED.

SOLUTION - USE LEADLESS COMPONENTS CURRENTLY AVAILABLE TO REDUCE THE REQUIRED AREA BY A RATIO OF 2 TO 1 WITH A CORRESPONDING WEIGHT REDUCTION. RELIABILITY MAY BE INCREASED DUE TO A REDUCTION IN THE NUMBER OF PLATED THRU HOLES REQUIRED FOR INTERCONNECTIONS.

400

(3369) TITLE - UTILIZATION OF LARGE SCALE INTEGRATION (LSI) TECHNIQUES

PROBLEM - THE DESIGN AND UTILIZATION OF LSI ELECTRONICS IN AN ADVANCED DEVELOPMENT PROGRAM IS NOT FEASIBLE BECAUSE OF THE INABILITY TO MAKE QUICK CHANGES.

SOLUTION - CONDUCT PROJECT FOR LSI DEVELOPMENT, QUALIFICATION, PRODUCTION ENGINEERING AND PILOT RUN FOR THE STINGER ALTERNATE MISSILE GUIDANCE ELECTRONICS.

220 550

(3411) TITLE - MANUFACTURE OF NON PLANAR PRINTED CIRCUIT BOARDS

PROBLEM - USE OF FLAT CIRCUIT BOARDS RESULTS IN COMPLEX AND EXPENSIVE INTERCONNECTIONS WITH LOWERED RELIABILITY.

SOLUTION - DEVELOP THE PROCESSES TO PRODUCE NON-PLANAR CIRCUIT BOARDS SHAPED TO FIT THE AVAILABLE COMPARTMENTS. CIRCUIT PATTERNS WILL BE EXPOSED ON THE INSIDE WITH A PROJECTION MECHANISM OR WITH SOFT X-RAYS. A METHOD OF MASS SOLDERING WILL BE DEVELOPED.

COMPONENT -- INTEGRATED ELECTRONICS (CONTINUED)

(3415) TITLE - AUTOMATIC PHOTOGRAPHIC PRODUCTION OF THICK FILM MICROCIRCUIT

200 200

PROBLEM - SCREEN PRINTING OF FINE LINES DOES NOT ALLOW HIGH DENSITY DUE TO RHEOLOGY OF ZINC SYSTEMS.

SOLUTION - DEVELOP THICK FILM HYBRID PROCESSING CAPABILITY INCLUDING AUTOMATIC PHOTOLITHOGRAPHIC TECHNIQUES AND ELECTROLYTIC LINE PLATEUP OF FINE LINE THICK FILM CIRCUITS.

(3444) TITLE - FULLY ADDITIVE MANUFACTURING FOR PRINTED WIRING BOARDS

200 200

PROBLEM - THE PRESENT SUBTRACTIVE METHOD OF PRODUCING CIRCUIT BOARDS IS WASTEFUL OF COPPER, SLOW AND EXPENSIVE.

SOLUTION - PRODUCE CIRCUIT BOARDS BY A FULLY ADDITIVE PROCESS STARTING WITH A BARE BOARD. THE WIRING PATTERN WILL BE BUILT UP USING AN ELECTROLESS METAL DEPOSITION SYSTEM.

COMPONENT -- OPTICS

(1054) TITLE - MFG PROCESS FOR HOLOGRAPHIC OPTICAL COMPONENTS

375

PROBLEM - FABRICATION TECHNIQUES FOR HOLOGRAPHIC OPTICAL COMPONENTS ARE LIMITED TO LAB SAMPLES OF SELECTED OPTICAL COMPONENTS. LIMITATIONS PLACED ON SYSTEM PERFORMANCE WHEN THE TECHNOLOGY IS TRANSFERRED FROM THE LAB TO MANUFACTURING IS NOT KNOWN.

SOLUTION - ESTABLISH A PILOT PROCESS FOR MAKING HOLOGRAPHIC OPTICAL ELEMENTS WHICH WILL BE USED TO DETERMINE AND OVERCOME THESE LIMITATIONS.

(3152) TITLE - PRODUCTION OF OPTICAL ELEMENTS (CAM)

300

PROBLEM - HIGH GRADE OPTICS IN MODERATE QUANTITY CANNOT BE PRODUCED AT LOW COST WITH REPEATABILITY.

SOLUTION - APPLY COMPUTER CONTROL TO PROCESS OPERATIONS WITH SENSOR CONTROL AND PROCESS FEEDBACK TO ASSURE HIGH YIELD.

(3445) TITLE - PRECISION MACHINING OF OPTICAL ELEMENTS

300 400 625

PROBLEM - EXISTING PRECISION MACHINING FACILITIES CANNOT KEEP UP WITH THE DEMAND, MEET OPTICAL DESIGN REQUIREMENTS, MEET PRODUCTION SCHEDULES, AND STAY WITHIN REASONABLE COST BOUNDARIES.

SOLUTION - INTEGRATE BOTH THE WELL PROVEN ERDA DEVELOPED SINGLE POINT DIAMOND MACHINING CAPABILITIES AND THE DEVELOPING INTERFEROMETRIC AIDED AND COMPUTER CONTROLLED TECHNOLOGY INTO A MANUFACTURING METHOD.

MMT FIVE YEAR PLAN  
RCS DRCMT 126

FUNDING (\$000)

PRIOR 80 81 82 83 84

COMPONENT -- SEEKERS

350

(1034) TITLE - MANF PROCESS FOR ACTIVE AIR DEFENSE SEEKERS

PROBLEM - MANUFACTURING PROCESSES FOR QUANTITY PRODUCTION OF ACTIVE AIR DEFENSE SEEKERS DOES NOT EXIST.

SOLUTION - A PRODUCTION TEST WILL BE DESIGNED TO CHECK PERFORMANCE CHARACTERISTICS AGAINST MANUFACTURING PARAMETERS.

(1053) TITLE - MFG PROCESS FOR INFRARED FOCAL PLANE ARRAY

PROBLEM - THE GREATEST OPPORTUNITY FOR FABRICATION OF INFRARED FOCAL PLANE ARRAYS IS TO MATE AN ARRAY OF IR DETECTORS TO A SILICON CHARGE COUPLED DEVICE. HOWEVER PROBLEMS ARE ENCOUNTERED IN ACHIEVING A RELIABLE INTERFACE BETWEEN THE CCD AND ARRAY OF DETECTORS.

SOLUTION - DEVELOP A PROCESS THAT WILL ALLOW AN INDIUM BUMP ON THE BACKSIDE OF EACH ELEMENT OF AN IR ARRAY WHICH CAN BE JOINED IN GOOD ELECTRICAL AND MECHANICAL CONNECTION WITH THE TERMINAL OF AN ELEMENT OF A CCD SIGNAL PROCESSING ARRAY.

(1064) TITLE - PRODUCTION OF INFRARED SEEKER ELECTRONICS USING VLSI (CAM)

PROBLEM - LOW COST, LIGHT WEIGHT, MINIMUM VOLUME GUIDANCE ELECTRONICS ARE REQUIRED FOR FUTURE FIRE AND FORGET MISSILE SYSTEMS. CURRENT PACKAGING USES DISCRETE COMPONENTS AND HERMETICALLY SEALED ENCLOSURES WITH CIRCUITS ON PC BOARDS ON MOTHERBOARDS IN HOUSINGS.

SOLUTION - USE FOUR OR FIVE STANDARD CHIPS FROM DOD PROGRAM IN VLSI (VERY LARGE SCALE INTEGRATED CIRCUITS) TECHNOLOGY AND DEVELOP MANUFACTURING PROCESSES TO PRODUCE INFRARED IMAGING SEEKER ELECTRONICS USING THIS TECHNOLOGY.

(1083) TITLE - IMP MFG PROC F/FOUR-IN DIAMETER FOCAL PLANE ARRAY SEEKERS

PROBLEM - STARING FOCAL PLANE ARRAY DETECTORS MAKE REDUCTION IN INFRARED SEEKER MECHANICAL COMPLEXITY AND SIZE NOT PREVIOUSLY POSSIBLE. ACHIEVING HIGH PRODUCTION RATE WITH HIGH YIELD IN FABRICATION OF THIS NEW TYPE SEEKERHEAD IS A PROBLEM

SOLUTION - ESTABLISH MANUFACTURING PROCEDURES FOR LARGE VOLUME HIGH YIELD PRODUCTION OF STARING FOCAL PLANE ARRAY DETECTORS AND SMALL DIAMETER SEEKERHEADS.

(1094) TITLE - PROD METH F/MILLIMTR MONOPULSE ANTENNA F/DIR FIRE APPL

PROBLEM - PROPER ALIGNMENT OF THE COMPONENTS OF THE ANTENNA SYSTEM OF A MISSILE SENSOR IS EXTREMELY DIFFICULT AND VERY COSTLY. SUBSTITUTION OF A FIVE HORN MONOPULSE ANTENNA FOR THE ROTATING FEED ANTENNA IS NECESSARY TO ATTAIN THE REQUIRED PHYSICAL ALIGNMENTS.

SOLUTION - ESTABLISH PRODUCTION METHODS FOR FABRICATING THE FIVE HORN ANTENNA IN A COMPACT PACKAGE COMPATIBLE WITH A FIVE MILLIRADIAN BEAMWIDTH AT 94 GHZ.

COMPONENT -- SEEKERS

(CONTINUED)

(1099) TITLE - MFG METH AND TECH F/PIN DIODES AT MILLIMETER WAVE FREQUENCY 300

PROBLEM - PIN DIODES MUST BE SEMED FROM A SILICON WAFER, BONDED INTO STACKS, LAPPED AND POLISHED ON THE SEWED EDGES, AND ATTACHED TO THE WALL OF A METAL WAVEGUIDE. ALSO, A HIGH TEMP REFRACTORY METALLIZATION SYSTEM IS NEEDED.

SOLUTION - ESTABLISH METHODS FOR WAFER SAWING, STACKING AND BONDING, AND FOR STACK SAWING, LAPPING, AND POLISHING IN ORDER TO OBTAIN A THREE DIMENSIONAL DIODE STRUCTURE. THEN FIT AND ATTACH POLISHED STACKS TO WAVEGUIDE WALL. ALSO SET UP A HIGH TEMP METAL SYST.

(3081) TITLE - PROD OF RADAR MONOPULSE SEEKERS USING PC + STRIPLINE TECH 200

PROBLEM - THE CURRENT RADAR MONOPULSE SEEKERS ARE COSTLY, COMPLEX HYBRID NETWORKS.

SOLUTION - APPLY PRINTED CIRCUIT AND STRIPLINE TECHNOLOGY TO THE FABRICATION OF SUCH A SEEKER TO REDUCE PER UNIT COST.

(3139) TITLE - MILLIMETER RADIOMETRIC SEEKERS FOR SUBMISSILE APPLICATION 415 375

PROBLEM - LOW QUANTITY PRODUCTION IS TOO COSTLY FOR THE SYSTEM REQUIREMENTS.

SOLUTION - PROVIDE AN ALIGNMENT AND TEST FIXTURE TO SPEED ASSEMBLY AND TEST OF THE SENS-HORN GIMBAL ASSEMBLY. ESTABLISH A METHOD OF MOLDING THE STEPS IN THE LENS. APPLY PHOTOLITHOGRAPHIC TECHNIQUES TO THE XMITTER/RCVR STRUCTURAL ASSEMBLY.

(3178) TITLE - IMPROVED MANUFACTURING PROCESSES FOR LASER IR/OPTICAL SEEKER 225 225

PROBLEM - FIBER OPTICS FIXTURE ARE DIFFICULT AND EXPENSIVE TO MAKE.

SOLUTION - REDUCE FIBER OPTICS FIXTURE DIFFICULTIES BY DEVISING METHODS TO REDUCE HANDLING OF FIBER FIXTURE AND DETECTOR ARRAY.

(3186) TITLE - IMPROVED MANUFACTURE OF INFRARED SUBMISSILE SEEKERS 500

PROBLEM - LOW YIELD OF SEEKER COMPONENTS IS DUE TO HANDLING AND CHECKOUT OF GYRO OPTICS.

SOLUTION - PROVIDE LOWER COST SPHERICAL ELEMENTS TO REPLACE THE ASPHERICS. PROVIDE A FIBER OPTIC CUTTING METHOD THAT WILL ELIMINATE THE NEED TO POLISH THE FIBER INDS. OPTIMIZE THE FIBER OPTIC MATERIALS TO EXTEND THE OPERATING RANGE TO LONGER WAVELENGTHS.

(3428) TITLE - IMPROVED TECHNIQUES FOR COMMON APERTURE MULTISPECTRUM SEEKER 259 350

PROBLEM - PRESENT METHODS FOR MAKING WIDE BAND ON A ONE AT A TIME BASIS, DOES NOT PERMIT GOOD CONTROL OF PERFORMANCE.

SOLUTION - MANUFACTURING TECHNIQUES ARE REQUIRED TO PRODUCE THESE COMPONENTS IN MODERATE QUANTITIES WITH CLOSER TOLERANCES.

COMPONENT -- SENSOR

(1079) TITLE - WIDE AREA MERCURY-CADMIUM-TELERIDE QUADRENT DETECTORS 350

PROBLEM - LARGE AREA MERCURY-CADMIUM-TELLURIDE QUADRENT DETECTORS FOR IR SEEKERS ARE EXPENSIVE BECAUSE OF HIGH MATERIAL COST AND LOW YIELD. THE MATERIAL IS HARD TO GROW TO THE RIGHT CHEMICAL BALANCE. SLICING, ION IMPLANTATION AND/OR DIFFUSION ARE TOUCHY.

SOLUTION - FIND THE EXACT CHEMISTRY FOR GOOD DETECTOR OUTPUT. LOOK AT CLOSED LOOP COMPUTER CONTROL OF CRYSTAL PULLING. OPTIMIZE X-RAY CHARACTERIZATION, SAWING, POLISHING, ION IMPLANTATION, AND TESTING.

COMPONENT -- SENSORS

(1098) TITLE - LARGE DIAMETER SILICON 400

PROBLEM - SILICON DETECTORS ARE NOW MADE IN .8 IN DIA WAFERS AND OCCUPY THE ENTIRE SURFACE. BUT TO ESTABLISH HIGHER PRODUCTION RATES THEY SHOULD BE FORMED IN 3 OR 4 IN WAFERS. BUT NO GOOD METHOD OF DICING ROUND DICE IS AVAILABLE.

SOLUTION - INVESTIGATE ETCHING, ULTRASONIC CAVITATION, LASER SCRIBING, SAWING, TRAPANNING, FOR CUTTING .8 IN DISCS FROM 3 IN WAFERS. REDUCE STRESS AND PREVENT FRACTURES.

(3175) TITLE - MANUFACTURING PROCESSES FOR SOLID STATE IMAGING SENSORS 280 250

PROBLEM - EXISTING PROCESSES ARE LOW YIELD AND NON-UNIFORM, MECHANICAL VAPOR DEPOSITION MUST BE OPTIMIZED.

SOLUTION - ESTABLISH THE PROCESSES CIRCUMVENTING PRESENT PROBLEMS ON WIRE BONDING, TWEAKING, TESTING, ETC.

(3177) TITLE - IMPROVED MANF. PROCESS FOR SUBMISSILE ELECTRONIC SUBSYSTEM 250 175

PROBLEM - PRESENT MANUFACTURING PROCESSES SUBSTANTIALLY INCREASE THE COST OF HOMING SUBSYSTEMS.

SOLUTION - INVESTIGATE VOLUME METHODS FOR PRODUCING ELECTRONIC HOMING SUBSYSTEMS.

(3277) TITLE - AUTOMATIC INERTIAL SENSOR FABRICATION 350 350

PROBLEM - INERTIAL SENSOR FABRICATION REQUIRES PRECISION MACHINING AND ASSEMBLY METHODS WITH SEVERAL ITERATIONS, ALL OF WHICH INCREASE COST.

SOLUTION - ESTABLISH AUTOMATIC FLUID FILL STATION AND SET UP PILOT STATION FOR AUTOMATIC BALANCING OF GYRO ROTORS BY LASER REMOVAL OF MATERIAL

FUNDING (\$000)

PRIOR 80 81 82 83 84

COMPONENT -- WINDOWS/RADOMES

(1042) TITLE - PRODUCTION OF COMPOSITE RADOME STRUCTURES

755

PROBLEM - THE BASIC MATERIAL FOR COMPOSITE RADOMES IS EXPENSIVE (\$25/LB). THE FABRICATION PROCEDURES FOR PRODUCING THE RADOME STRUCTURE ARE COMPLEX AND EXPENSIVE, WITH SOME PROCEDURES BEING PROPRIETARY.

SOLUTION - ESTABLISH FIBERGLASS REINFORCED TEFLON AS A REPLACEMENT FOR THE CURRENT DUAL WALL BONDED PROPRIETARY MATERIAL (OURVOID). OPTIMUM PROCESSING WILL BE SELECTED BASED ON MECHANICAL PROPERTIES AND SLED TEST RESULTS AND WILL BE SCALED UP.

(3176) TITLE - MANUFACTURE OF SILICON NITRIDE RADOMES

390 350

PROBLEM - THERE IS NO EXISTING ECONOMICAL MANUFACTURING PROCESSES FOR LARGE RADOMES FROM CURRENT MATERIALS.

SOLUTION - SLIPCAST SILICON POWDER AND FIRE THE RADOME IN A NITROGEN ATMOSPHERE.

(3426) TITLE - IMPROVED PROCESSES FOR MIRRORS AND WINDOWS FOR HE LASERS

250 350

PROBLEM - MIRRORS AND WINDOWS FOR HIGH ENERGY LASER APPLICATION ARE EXPENSIVE TO FABRICATE AND HAVE POOR REPRODUCIBILITY.

SOLUTION - ESTABLISH METHODS FOR PRODUCING MODERATE QUANTITIES OF MIRRORS AND WINDOWS AT LOWER COST AND GREATER UNIFORMITY.

(3432) TITLE - IMPROVED IR DOME MATERIALS

150

PROBLEM - THE CURRENT PROCESS FOR THE PRODUCTION OF SILICON NITRIDE, A BATCH PROCESS, STARTS WITH HIGH PURITY SILICON AND TAKES PLACE AT 1400 C IN AN OXYGEN FREE ATMOSPHERE FOR SEVERAL DAYS.

SOLUTION - THE PROPOSED PROCESS, RECENTLY DEVELOPED A AMMRC, USES LOW GRADE FERRO-SILICON AND OPERATES AT 1100-1250 C IN A CONTINUOUS PROCESS. THE MATERIAL PRODUCED IS EQUAL TO CURRENTLY PRODUCED SILICON NITRIDE.

\*\*\*\*\*  
\* C A T E G O R Y \*  
\*-----\*  
\*MISSILE STRUCTURE \*  
\*\*\*\*\*

COMPONENT -- AIRFRAMES-COMPOSITES

(1020) TITLE - MFG PROCESSES FOR FUSED SILICA FIBERS

458 521

PROBLEM - THERE IS NO COMMERCIAL SOURCE FOR HIGH PURITY FUSED SILICA FIBERS.

SOLUTION - SCALE-UP PROCEDURES USED FOR FIBER OPTICS APPLICATIONS AND SET UP A PILOT PRODUCTION LINE TO PRODUCE FUSED FIBERS OF STRUCTURAL QUALITY

MMT FIVE YEAR PLAN  
RCS DRCHT 126

FUNDING (\$000)

PRIOR 80 81 82 83 84  
-----

COMPONENT -- AIRFRAMES-COMPOSITES

(CONTINUED)

(1026) TITLE - LO-COST MFG TECHNIQUES FOR HI PRODUCTION MISSILE VANES (CAM)	305	360			
PROBLEM - METAL CONTROL VANES, FINS AND MISSILE FAIRINGS CAUSE HIGH COST, WEIGHT PENALTIES AND LONG LEAD TIME					
SOLUTION - METAL CONTROL VANES, FINS AND MISSILE FAIRINGS CAUSE HIGH COST, WEIGHT PENALTIES AND LONG LEAD TIME.					
(1080) TITLE - LOW COST CARBON/CARBON NOSETIPS	550	490	450		
PROBLEM - THE WEAVING PROCESS TO FABRICATE CARBON/CARBON NOSETIP PREFORMS IS LABOR INTENSIVE BECAUSE OF THE FINEWEAVE CENTER-TO-CENTER YARN SPACINGS. IN ADDITION, PREFORMS USE EXPENSIVE GRAPHITE YARN AND REQUIRE LONG IMPREGNATION CYCLES.					
SOLUTION - DEVELOP OPTIMAL FABRICATING PROCEDURES FROM LOWER COST MATERIALS, PITCH RESIN AND T-300 CARBON FIBERS. UTILIZATION OF SHORTER DENSIFICATION CYCLES PREFORMS, AND FIBER SPACINGS WILL PROVIDE THE MEANS FOR REDUCING CYCLE TIMES.					
(1082) TITLE - HIGH ANGLE TAPE WRAPPED HEATSHIELDS	900	600	700		
PROBLEM - DATA HAS SHOWN THAT THE EROSION PERFORMANCE OF TAPE WRAPPED HEATSHIELDS IMPROVES AS THE SHINGLE ANGLE INCREASES ABOVE 30 DEGREES. CURRENT MFG TECHNIQUES DO NOT LEND THEMSELVES TO HIGH WRAP-ANGLE HEATSHIELDS.					
SOLUTION - DEVELOP IMPROVED WRAPPING TECHNIQUES TO CURRENT TAPE WRAPPING EQUIPMENT AND PROCESSING TECHNOLOGY.					
(3335) TITLE - ADVANCED COMPOSITE SUBSTRUCTURES FOR MISSILES		300			
PROBLEM - THE CONVENTIONAL APPROACH FOR BUILDING UP STRUCTURE FROM DETAILED PARTS RESULT IN HIGH COST.					
SOLUTION - ADVANCED COMPOSITE STRUCTURES SHOULD PROVIDE AND ECONOMICAL ALTERNATIVE. THE COMPOSITES ARE BUILT UP UNCURED AND ASSEMBLED IN THIS STATE. THE ENTIRE STRUCTURE IS THEN CURED AS AN ASSEMBLY. MINOR MISMATCHES ARE RELIEVED ASSOFTENING AND CURING OCCURS.					
(3385) TITLE - UTILIZATION OF COMMERCIAL GRADE KEVLAR 49		200			
PROBLEM - COMMERCIAL GRADE KEVLAR 49 DIFFERS FROM AEROSPACE GRADE IN THAT THE COMMERCIAL ROVING IS LARGER IN DIAMETER AND DOES NOT ACCEPT THE EXISTING RESIN SYSTEM.					
SOLUTION - ESTABLISH RESIN THAT IS MORE COMPATIBLE WITH COMMERCIAL GRADE WINDING PROCESS THAT IMPROVES PROPERTIES OF TUBES MADE OF COMMERCIAL GRADE KEVLAR					

COMPONENT -- AIRFRAMES-COMPOSITES (CONTINUED)

(3420) TITLE - ADV. COMPOSITE MATERIAL FOR GUID. INNER SHELL SPT. STRUCTURE 225 225

PROBLEM - GUIDANCE INNER SHELL SUPPORT AND SIMILAR STRUCTURES ARE COMPLEX IN SHAPE AND EXPENSIVE TO FABRICATE FROM THE ALUMINIUM CASTINGS.

SOLUTION - WEIGHT REDUCTION, INCREASED STRENGTH AND GREATER STRUCTURAL DAMPING CAN BE ACHIEVED AT A LOWER COST WITH COMPOSITE MATERIALS. DIRECTIONAL STRENGTH PROPERTIES AND STIFFNESS CAN BE ACHIEVED BY PROPER FIBER ORIENTATION.

COMPONENT -- AIRFRAMES-METAL/PLASTIC

(3179) TITLE - IMPROVED MANUFACTURING PROCESS FOR SUBMISSILE AIRFRAMES 200 175

PROBLEM - CURRENT TECHNIQUES OF MANUFACTURING TERMINALLY GUIDED SUBMISSILE AIRFRAMES REQUIRE ADEQUATE PROCESS CONTROL AND DESIGN RELIABILITY.

SOLUTION - ALTHOUGH THE USE OF PLASTICS IN THESE APPLICATIONS ARE CONSIDERED STATE-OF-THE-ART CERTAIN PROCESSES MUST BE DEVELOPED FOR THE INDIVIDUAL MISSILE APPLICATION.

COMPONENT -- COMPONENTS

(1046) TITLE - CONDUCTIVE PLASTIC PARTS FOR EMI SHIELDING 225

PROBLEM - HELLFIRE IS REQUIRED TO BE DESIGNED SO THEY WILL NEITHER EMANATE NOR BE SUSCEPTIBLE TO ELECTROMAGNETIC ENERGY. CORROSION PROTECTION FOR ELECTRICALLY IDEAL METAL SURFACES NEGATES EMI SHIELDING. ALSO MOLDED AND METALLIZED PLASTICS ARE COST PROHIBITIVE.

SOLUTION - MOLD HELLFIRE FROM CONDUCTIVE PLASTIC THAT WILL BE CONSISTENT AND UNIFORMLY CONDUCTIVE AND FREE FROM DEGRADATION BY CORROSION

(1073) TITLE - REAL TIME ULTRASONIC IMAGING 200 200

PROBLEM - EXISTING ACOUSTICAL HOLOGRAPHY INSP. SYS PRODUCES UNSATISFACTORY VIDEO IMAGES DUE TO POOR RESOLUTION, SIGNAL NOISE AND LOW SPATIAL FREQ. ABERRATIONS.

SOLUTION - A 3 CHANNEL PIPELINE PROCESSOR WITH ASSOCIATED 512X512X8 MEMORIES WITH A 30 FRAMES/SEC DISPLAY CAPABILITY. THIS SYS WOULD ELIMINATE ABERRATION, IMPROVE CONTRAST, AND REDUCE SIGNAL NOISE.

(3288) TITLE - MANUFACTURING TECHNOLOGY FOR DIE CASTING 200

PROBLEM - WEIGHT AND SPACE CONSTRAINTS HAVE RESULTED IN COMPLEX AND HIGH DENSITY CONFIGURATIONS OF METAL PARTS WHICH ARE MACHINED.

SOLUTION - ESTABLISH AND PROVE-OUT DIE CASTING TECHNIQUES FOR THESE COMPLEX CONFIGURATION.

MMT FIVE YEAR PLAN  
RCS EXCMT 126

FUNDING (\$000)

PRIOR 80 81 82 83 84  
-----

COMPONENT -- FORMING

(3282) TITLE - CONFORM EXTRUSION PROCESS

375 375

PROBLEM - CONSIDERABLE COSTS ARE INCURRED IN TRANSPORTATION, DAMAGE AND LOSS OF SEMI-FINISHED PARTS.

SOLUTION - REVIEW MISSILE PARTS AND DETERMINE IF THEY CAN BE PRODUCED BY CONFORM PROCESS.

COMPONENT -- JOINING

(3144) TITLE - USE OF INFRARED DETECTION FOR AUTO. CONTROL WELD PENETRATION

150 150

PROBLEM - THERE IS NO ACCEPTABLE MEANS OF CONTROLLING WELD PENETRATION ON COMPONENTS FABRICATED FROM THIN SHEETS OF HIGH STRENGTH STEEL ALLOYS.

SOLUTION - A COMMERCIALY USEABLE SYSTEM WILL BE DEVELOPED FOR ASSURING FULL WELD PENETRATION. THE SYSTEM CAN DETECT SMALL CHANGES THAT AFFECT PENETRATION AND AUTOMATICALLY CORRECT OR CHANGE THE WELDING VARIABLE TO PRODUCE COMPLETE PENETRATION.

(3219) TITLE - AUTOMATIC POLYMER ATTACHMENT PRODUCTION METHODS

200 200

PROBLEM - PRESENT TECHNOLOGY EMPLOYS A POLYMER DISPENSING MACHINE WHICH IS OPERATED MANUALLY, A TIME CONSUMING AND COSTLY PROCESS.

SOLUTION - THIS PROJECT IS TO DEVELOP AN AUTOMATIC PRODUCTIO POLYMER ATTACHMENT METHOD THAT WILL DISPENSE THE EXACT AMOUNT OF POLYMER ONTO A SUBSTRATE, PICK THE CHIP FROM EHT WAFER PACK, AND OPIENT THE CHIP BEFORE PLACING IT ONTO THE POLYMER.

(3304) TITLE - ESTABLISH INERTIAL WELDING

400

PROBLEM - CRITICAL HIGH STRENGTH MISSILE AND LAUNCHER FORGING DETAIL REQUIRE LONG LEAD TIMES AND ARE EXPENSIVE.

SOLUTION - ADAPT TO AEROSPACE USE MANUFACTURING PROCESS FOR JOINING DETAILS AND PROVIDE HIGH STRENGTH STRUCTUAL COMPONENTS.

COMPONENT -- MACHINING

(1021) TITLE - COMPUTERIZED PROD PROC PLAN FOR MACH CYLINDRICAL PARTS (CAM)

240 250

PROBLEM - PRESENT MANUAL METHOD FOR PRODUCTION PROCESS PLANNING OF MACHINED CYLINDRICAL METAL COMPONENTS ARE INADEQUATE DUE TO HIGH PROCESS PLANNING COSTS AND A LACK OF STANDARDIZATION.

SOLUTION - DEVELOP A COMPUTER SOFTWARE SYSTEM FOR PROCESS PLANNING OF MACHINED CYLINDRICAL PARTS. THE SYSTEM WILL BE MANUFACTURER-INDEPENDENT AND WILL INCORPORATE PROCESS DECISION MODELING.

FUNDING (\$000)

PRIOR 80 81 82 83 84  
-----

COMPONENT -- MACHINING (CONTINUED)  
(3302) TITLE - ELECTRO DISCHARGE MACHINING PROCEDURE 320 320

PROBLEM - THERE ARE MANY FABRICATION PROBLEMS DUE TO TIGHT TOLERANCE REQUIREMENTS IN FABRICATING MOUNTING HOLES FOR ARRAY ELEMENTS OF THE RADAR ANTENNAS.

SOLUTION - ESTABLISH TOOLING AND TECHNIQUES FOR FORMING HOLES IN FULL-SIZE ARRAY ELEMENT SUPPORT PLATES BY ELECTRO DISCHARGE MACHINING.

\*\*\*\*\*  
\* C A T E G O R Y \*  
\*-----\*  
\*PROPULSION SYSTEM \*  
\*\*\*\*\*

COMPONENT -- MOTOR CASES

(1087) TITLE - APPLICATION OF COMMERCIAL GRADE KEVLAR TO ROCKET MOTOR COMP 400

PROBLEM - CURRENT MILL PROCEDURES AND COMPONENT PROCSSING METHODOLOGY HAS NOT BEEN ESTABLISHED FOR PRODUCING ROCKET MOTORS FROM COMMERCIAL GRADE KEVLAR

SOLUTION - OPTIMIZE MILL PROCEDURES AND MOTOR COMPONENT PROCESSING METHODOLOGY FOR COMMERCIAL GRADE KEVLAR AND EVALUATE T+E PERFORMANCE IN A ROCKET MOTOR COMPONENT ENVIRONMENT

(1088) TITLE - OPTIMIZED MANDREL FAB AND UTILIZATION F/COMP MOTOR CASES 400

PROBLEM - AN INORDINATE AMOUNT OF HAND WORK IS REQUIRED FOR PREPARING, REPAIRING AND DISMANTLING MANDRELS FOR WINDING AND CURING COMPOSITES. IT IS DESIRABLE TO OPTIMIZE PRODUCTION PROCEDURES TO OBTAIN THE LOWEST UNIT COST WHILE MAINTAINING RELIABILITY.

SOLUTION - UTILIZE NET METAL MANDREL APPROACH BY ASSEMBLING THEM FROM SEGMENTS WHICH WOULD BE REMOVED BY DISASSEMBLY OF THE SEGMENTS. RECENT R+D EFFORTS IN THIS AREA HAVE LED TO HIGHLY PROMISING CONCEPTS.

(1089) TITLE - INTEGRAL ROCKET MOTOR COMPOSITE POLE PIECES AND ATTACHMENTS 250

PROBLEM - CURRENT FILAMENT WOUND COMPOSITE ROCKET MOTOR CASES REQUIRE FORGED METAL POLE PIECES, NOZZLE CLOSURE ATTACHMENT RINGS, AND OTHER ATTACHMENT RINGS. THESE COMPONENTS ARE EXPENSIVE, AND REQUIRE LONG LEAD TIME PROCUREMENT.

SOLUTION - ESTABLISH A FILAMENT WINDING PRODUCTION PROCESS FOR FABRICATING COMPOSITE MOTOR CASES WITH INTEGRAL POLE PIECES, AFT ATTACHMENT RINGS, AND FORWARD AND AFT DOME SECTIONS.

MMT FIVE YEAR PLAN  
RCS DRCMT 126

FUNDING (\$000)

PRIOR 80 81 82 83 84  
-----

COMPONENT -- MOTOR CASES

(CONTINUED)

(3142) TITLE - PROD METHOD FOR LOW COST PAPER MOTOR COMPONENTS

275 200

PROBLEM - HIGH VOLUME MISSILES AND ROCKETS USE HIGH STRENGTH TO WEIGHT METAL MOTOR CASES WHICH ARE A COSTLY ITEM.

SOLUTION - ESTABLISH WINDING TECHNIQUES FOR TURNING OUT LOW COST PAPER-PHENOLIC MOTOR CASE BODIES ON STANDARD INDUSTRIAL TOOLING.

(3294) TITLE - PRODUCTION PROCESS FOR ROTARY ROLL FORMING

300 175

PROBLEM - MECHANICALLY JOINING OR WELDING A CONVENTIONAL CLOSURE TO COMMERCIAL TUBING IS EXPENSIVE.

SOLUTION - DEVELOP METHODS FOR PRODUCING INTEGRAL NOZZLES WITH TUBULAR PRODUCTS USING ROTARY ROLL FORMING TECHNIQUES.

(3343) TITLE - FABRICATION OF INTEGRATED CASE AND GRAIN

500

PROBLEM - CONSIDERABLE LABOR IS REQUIRED TO MANUFACTURE ASSEMBLE AND FINISH PROPULSION SYSTEMS.

SOLUTION - DEVELOP STRIP WOUND INTEGRATED CASE AND GRAIN PROCESS TO INTEGRATE MANUFACTURE ASSEMBLY AND FINISHING IN LOW COST AUTOMATIC PRODUCTION LINE.

(3419) TITLE - THERMOMECHANICAL METHODS FOR HIGH STRENGTH STL RKT MTR CASES

500

PROBLEM - THE MANUFACTURING PROCESSES FOR HIGH STRENGTH ROCKET MOTOR CASES FOR THE MLRS (FORMERLY GSRs) RESULT IN A RESIDUAL STRESS PATTERN (RADIAL) THAT DOES NOT TAKE FULL ADVANTAGE OF THE MATERIAL PROPERTIES.

SOLUTION - THIS PROGRAM WOULD DEVELOP AUTOMATED PROCEDURES TO PERFORM THERMO-MECHANICAL FABRICATION OF THE STEEL MOTOR CASES. THIS PROCESS WILL PRODUCE A MORE DESIRABLE STRESS PATTERN FOR INCREASED PERFORMANCE.

COMPONENT -- MOTOR COMPONENTS

(1036) TITLE - PRODUCTION METHODS FOR VSTT TURBINE ROTORS

290

PROBLEM - TURBINE ROTORS ARE SUBJECT TO STRESS AND FATIGUE LEVELS AS ENGINE THRUST INCREASES.

SOLUTION - IMPLEMENT PILOT PRODUCTION PROGRAM TO ESTABLISH COST EFFECTIVE PRODUCTION AND TEST TECHNIQUES TO FABRICATE TURBINE ROTORS WITH INCREASED STRESS AND FATIGUE LEVELS.

FUNDING (\$000)

PRIOR 80 81 82 83 84

COMPONENT -- MOTOR COMPONENTS

(CONTINUED)

(1050) TITLE - LOW COST BRAIDED ROCKET MOTOR COMPONENTS

430 400

PROBLEM - ROCKET MOTOR COSTS TO MEET DESIGN-TO-COST PRODUCTION GOALS HAVE DICTATED REEVALUATION OF MATERIALS AND PROCESSES. MISSILE CASES COMPRISE 1/2 OF PROPULSION SYSTEM COST. EMPHASIS MUST BE PLACED ON ESTABLISHING NEW COMPONENT MFG PROCESSES.

SOLUTION - OPTIMIZE THE PRODUCTION PROCEDURES AND RATES FOR INTEGRALLY BRAIDED CASE/NOZZLE COMPONENTS TO PROVIDE PRODUCTION ENGINEERING DATA ESSENTIAL TO FUTURE MOTOR COMPONENT REQUIREMENTS.

(1051) TITLE - REPLACEMENT OF ASBESTOS IN ROCKET MOTOR INSULATIONS

475 475

PROBLEM - PRESENT ASBESTOS CONTAINING INSULATORS CAN NO LONGER BE MANUFACTURED AFTER 1981 DUE ITS BEING IDENTIFIED AS A CARCINOGEN. THUS THE GOVT HAS LOST THE CAPABILITY OF USING INSULATING MATERIALS THAT HAS PROVEN TO BE AN EXCELLENT THERMAL BARRIER.

SOLUTION - FILLER MATERIALS OTHER THAN ASBESTOS ARE AVAILABLE. FIBER GLASS AND SILICA HAVE BEEN USED IN SPECIALIZED APPLICATIONS AND WOLLASTONITE LOOKS PROMISING. MATERIALS SPECS AND MOTOR TEST VERIFICATION MUST BE DONE BEFORE A SUBSTITUTE MATERIAL CAN BE USED.

(1086) TITLE - COBALT REPLACEMENT IN MARAGING STEEL F/ROCKET MOTOR COMP

430

PROBLEM - CURRENT HIGH PERFORMANCE ROCKET MOTOR COMPONENTS UTILIZE MARAGING STEELS IN LARGE QUANTITIES. COBALT, ONE OF THE KEY INGREDIENTS COMES FROM POLITICALLY SENSITIVE AREAS AND IS BECOMING DIFFICULT TO OBTAIN.

SOLUTION - OPTIMIZE MILL PROCEDURES AND EVALUATE IN A ROCKET MOTOR THE NEW COBALT FREE MARAGING STEEL ALLOYS.

COMPONENT -- NOZZLES

(3396) TITLE - INJECTION MOLDING OF ONE PIECE NOZZLES

180 180

PROBLEM - SOLID PROPULSION SYSTEM NOZZLES ARE BEING FABRICATED BY USING A NUMBER OF MATERIALS AND COMPONENTS JOINED TOGETHER BY VARIOUS TECHNIQUES. SUBSTANTIAL PRODUCTION TIME AND COST ARE INVOLVED AS A RESULT OF THE MULTI-COMPONENT CONSTRUCTION

SOLUTION - ESTABLISH MANUFACTURING PROCESS FOR INJECTION MOLDING LOW COST ONE-PIECE SOLID PROPELLANT MOTOR NOZZLES.

(3423) TITLE - LOW COST/HIGH PERFORMANCE FIBROUS GRAPHITE ROCKET NOZZLES

300 500

PROBLEM - ROCKET SYSTEMS USING HIGH PERFORMANCE CARBON/CARBON OR PYROLYTIC GRAPHITE NOZZLES INCUR HIGH COMPONENT COST.

SOLUTION - THIS PROJECT WILL SCALE UP THE FIBROUS GRAPHITE PROCESS TO MAKE FULL-SCALE NOZZLE COMPONENTS AND WILL EXTEND NOZZLE TEST DATA.

COMPONENT -- PROPELLANTS

650

(1037) TITLE - LOW COST EXTRUDABLE PYROTECHNIC PELLETTING PROCESS

PROBLEM - PELLETTING OPERATION IS A FUNCTION OF PELLET SIZE, THE SMALLER THE PELLET THE GREATER THE COST.

SOLUTION - DEVELOP EXTRUDABLE COMPOSITIONS WITH THE SAME IGNITION CHARACTERISTICS AS PELLETS. DESIGN CONTINUOUS OPERATION TO PRODUCE VARIOUS SIZED PELLETS.

650

(1038) TITLE - PROD OF NITRO POLYMERS FOR SMOKELESS PROPELLANTS

PROBLEM - NITROCELLULOSE PLASTICIZER BINDER HAS A VERY LIMITED FLEXIBILITY FOR FORMULATION OF SMOKELESS PROPELLANT COMPOSITIONS.

SOLUTION - MAKE PRODUCTION OF POLYETHYLENE GLYCOL NITRAMINE POLYMER COMMERCIALY AVAILABLE.

850 1227

(1044) TITLE - CONTINUOUS PROCESS FOR PROPELLANT MANUFACTURE

PROBLEM - PROPELLANT MANUFACTURE IS GENERALLY A BATCH PROCESS WITH INHERENT PROBLEMS. CURE ACCELERATORS MUST BE AVOIDED SINCE THEY SHORTEN POT LIFE. THE PROCESS HAS HIGH LABOR REQUIREMENTS. HIGH VISCOSITIES RESULT IN DISCARDING THE BATCH.

SOLUTION - A CONTINUOUS MIXING AND MOTOR LOADING PROCESS WILL REDUCE PRODUCTION LABOR AND FACILITIES, AND IMPROVE PROPELLANT QUALITY AND RELIABILITY. SAFETY PROBLEMS RELATED TO QUANTITY DISTANCES CAN BE MINIMIZED.

138

(3317) TITLE - CASTING OF PROPELLANTS

PROBLEM - THE END BURNING SUSTAINER GRAIN FOR STINGER IS PRESENTLY CAST AND CURED, MACHINED, INHIBITED WITH BOOT WHICH IS BONDED TO EXTERIOR OF GRAIN.

SOLUTION - DEVELOP CAST-IN-BOOT PROCESS TO CAST GRAIN DIRECTLY INTO INHIBITOR BOOT.

475

(3404) TITLE - MANUFACTURE OF ULTRAFINE AMMONIUM PERCHLORATE

PROBLEM - BURNING RATES OF SPECIFIC SYSTEMS WILL OFTEN BE OUT OF SPECIFICATIONS BECAUSE OF THE UFAP MANUFACTURE AND REPRODUCIBILITY PROBLEMS.

SOLUTION - THIS PROJECT WILL ESTABLISH A REPRODUCABLE METHOD OF GRINDING UFAP, EVALUATE THE QUALITY AND REPRODUCIBILITY IN HIGH RATE COMPOSITE PROPELLANT FORMULATIONS AND ESTABLISH QUALITY CONTROL AND PROCESS SPECIFICATIONS.

FUNDING (\$000)

PRIOR 80 81 82 83 84

-----

COMPONENT --- PROPELLANTS

(CONTINUED)

(3447) TITLE - SCALE UP AND DEMO FOR THE RECOV OF CARBORANE FROM WASTE PROP 375 132

PROBLEM - THE PRODUCTION OF N-HEXYLCARBORANE (NHC) RESULTS IN UP TO 10 PCT REJECTED MATERIAL BECAUSE IT WILL NOT MEET BALLISTIC RATE REQUIREMENTS.

SOLUTION - THE SCRAP PROPELLANT CON BE DISSOLVED IN PENTANE, DRIED AND DISTILLED TO PURIFY IT. THE NHC THAT WOULD BE SCRAPPED IS THUS RECOVERABLE. THIS PROJECT WILL SCALE UP THE LABORATORY PROCESS SUCH THAT THE TOTAL PROCESS CAN BE DEMONSTRATED.

(3448) TITLE - RECOVERY OF DIBORANE IN THE MANUFACTURE OF NHC 440

PROBLEM - THERE IS AN 8% LOSS OF UNREACTED DIBORANE FROM THE PROCESS USED TO PRODUCE NHC

SOLUTION - RECOVER AND RECYCLE THE DIBORANE WITH A DIMETHYL-ZINC CHLORIDE PROCESS

(3449) TITLE - OPTIONAL PROPELLANT INGREDIENTS 250 359

PROBLEM - A NUMBER OF CHEMICAL INGREDIENTS USED IN SOLID ROCKET PROPELLANTS HAVE BECOME UNAVAILABLE BECAUSE SOME OF THE REAGENTS ARE HAZARDOUS.

SOLUTION - STUDIES SHOW THAT ISOPHRONE DIISOCYANATE (IPDI) CAN BE MADE IN A BATCH PROCESS WITHOUT USING PHOSGENE. THIS LABORATORY PROCESS WILL BE SCALED UP.

(3450) TITLE - SCALE UP & DEMONSTRATION OF A PROCESS FOR DIBORANE 950 900

PROBLEM - THE PRESENT PROCESS IS A BATCH OPERATION AND BECAUSE OF THE DIFFICULTY IN CONTROLLING THE CHEMISTRY THE BATCHES ARE SMALL RESULTING IN HIGH LABOR COSTS.

SOLUTION - IT IS ESTIMATED THAT DIBORANE CAN BE PRODUCED USING INEXPENSIVE RAW MATERIALS- BORIC ACID, METHANOL AND SODIUM HYDRIDE IN A SIMPLE CONTINUOUS PROCESS THAT IS EASILY CONTROLLED. A PILOT FACILITY WILL BE BUILT TO DEVELOP THE PROCESSES.

COMPONENT -- PROPELLENTS

(1035) TITLE - DEMONSTRATION OF LOW COST CARBORANE MODIFIER 750

PROBLEM - NHC IS USED AS A BALLISTIC MODIFIER FOR SOLID ROCKET PROPELLANTS BUT IS VERY EXPENSIVE DUE TO A LOW YIELD PROCESS.

SOLUTION - INVESTIGATE ALKYNE PROCESS FOR PRODUCTION OF NHC TO REDUCE NET PRODUCT COST.

MMT FIVE YEAR PLAN  
RCS DRCMT 126

\*\*\*\*\*  
\* C A T E G O R Y \*  
\*-----\*  
\*TEST EQUIPMENT \*  
\*\*\*\*\*

FUNDING (\$000)

PRIOR 80 81 82 83 84

COMPONENT -- ELECTRICAL TEST EQUIPMENT

(3115) TITLE - ENGINEERING FOR CALIBRATION EQUIPMENT 3121 747 811 883 800 800

PROBLEM - MEASUREMENT SCIENCES OR METROLOGY MUST BE CONTINUALLY ADVANCED IN RELEVANT TECHNOLOGY AREAS TO KEEP PACE WITH MANY ARMY PROGRAMS.

SOLUTION - ADVANCEMENTS MUST BE MADE BY DERIVING NEW TYPES OF STANDARDS.

COMPONENT -- ELECTRONIC COMPONENTS

(1023) TITLE - DIGITAL FAULT ISOLATION FOR HYBRID MICROELECTRONIC MODULES 300

PROBLEM - HYBRID MICROELECTRONIC MODULES REQUIRE A SIGNIFICANT INCREASE IN DIGITAL FAULT ISOLATION CAPABILITY. INTERNAL PROBING IS OFTEN NECESSARY TO DIAGNOSE PROBLEMS.

SOLUTION - DEVELOP A MANUFACTURING TECHNOLOGY FOR EMPLOYING THE PROBE TRACE METHOD FOR FAULT ISOLATION IN THE PRODUCTION OF HYBRID MICROELECTRONIC MODULES.

(1060) TITLE - ELECTRICAL TEST AND SCREENING OF CHIPS 375 375

PROBLEM - ONE UNRELIABLE CHIP IN MILITARY ELECTRONIC ASSEMBLIES CAUSES REJECTION OR DESTRUCTION OF THE ENTIRE PACKAGE. PRESENT MEANS FOR DETERMINING CHIP RELIABILITY OR INTEGRITY IS A PROBE TESTING TECHNIQUE WHICH IS TIME CONSUMING AND DESTRUCTIVE.

SOLUTION - PLACE A MONOLITHIC CHIP TESTING DEVICE AT THE POINT JUST BEFORE THE CHIP IS BONDED TO THE SUBSTRATE. INCLUDE ON THE PROBE A NON-DESTRUCTIVE POINT AND A METHOD FOR OXIDE REMOVAL.

(1076) TITLE - PATTERN RECOGNITION OF COMPONENTS F/HYBRID CIRCUIT SUBSTRATE 400 400

PROBLEM - OPTICAL INSPECTION OF HYBRIDS BY AN OPERATOR IS INEFFICIENT DUE TO HUMAN FATIGUE INTRODUCED BY REPETITIVE INSPECTION OF SMALL CIRCUITS. A COMPUTER CONTROLLED OPTICAL PATTERN RECOGNITION SYSTEM FOR COMPLEX HYBRID CIRCUITS IS NEEDED.

SOLUTION - MODIFY EXISTING OPTICAL PATTERN RECOGNITION EQUIPMENT TO RECOGNIZE COMPONENT AND BOND PAD ALIGNMENT FOR LARGE NUMBERS OF ELECTRONIC DEVICES PER SUBSTRATE.

(3169) TITLE - AUTO OPTICAL INSPECTION OF PC BOARDS + COMPONENTS(CAH) 275 90

PROBLEM - OPERATOR FATIGUE ALLOWS MANY BAD PCBs TO PASS VISUAL INSPECTION.

SOLUTION - PROVIDE AN AUTOMATED OPTICAL COMPARATOR TO ELIMINATE THE NEED FOR HUMAN INSPECTOR.

FUNDING (\$000)

PRIOR 80 81 82 83 84  
-----

COMPONENT -- ELECTRONIC COMPONENTS (CONTINUED)

425

(3243) TITLE - ANALOG FAULT ISOLATION OF PRINTED CIRCUIT BOARDS

PROBLEM - MANUAL FAULT ISOLATION AND TROUBLE SHOOTING METHODS ARE SLOW.  
SOLUTION - ESTABLISH AUTOMATIC FAULT ISOLATION AND TROUBLE SHOOTING METHODS FOR ANALOG CIRCUIT ASSEMBLIES.

490

(3251) TITLE - HIGH TEMPERATURE OPERATING TESTS FOR MICROCIRCUITS

PROBLEM - LIFE TESTS ON SEMICONDUCTOR DEVICES ARE IMPRACTICAL DUE TO THE HUNDREDS OF THOUSANDS OF TEST HOURS REQUIRED.

SOLUTION - IMPLEMENT HIGH TEMPERATURE OPERATING TESTS AS EARLY IN THE MANUFACTURING CYCLE AS FEASIBLE.

125

(3322) TITLE - INFRARED ELEMENT TESTING

PROBLEM - IR SYSTEM OPTICAL ELEMENTS ARE SPECIFIED IN TERMS OF MIL-O-13830 WHICH REQUIRES SUBJECTIVE JUDGEMENT.

SOLUTION - ESTABLISH A SUPPLEMENT TO MIL-O-13830, OPTICAL DESIGN GUIDANCE FOR FUNCTION TESTING, STANDARD TESTS AND EQUIPMENT.

125

COMPONENT -- GENERAL

200

(1052) TITLE - ACOUSTIC EMISSION OF MOTOR CASE WELD FABRICATION

PROBLEM - FABRICATION OF ROCKET MOTOR CASES BY ROLL AND WELD PROCESS IS UNATTRACTIVE BECAUSE OF HIGH COST FROM EXTENSIVE NON-DESTRUCTIVE INSPECTION TECHNIQUES REQUIRED. A TECHNIQUE IS TO DETECT DEFECTS AS THEY FORM THUS PERMITTING IMMEDIATE REPAIR.

SOLUTION - DEVELOP AN ON-LINE, REAL TIME ACOUSTIC EMISSION WELD MONITORING TECHNIQUE. THIS PROJECT WILL EXTEND THE RESULTS OF AN MIT PROJECT TO THE FULL PRODUCTION CONFIGURATION.

300

COMPONENT -- X-RAY AND N-RAY

500

(3241) TITLE - AUTOMATIC X-RAY READER TEST EQUIPMENT FOR 3D X-RAYS

PROBLEM - X-RAY IS LIMITED TO A TWO DIMENSIONAL FORMAT AND IS DEPENDENT ON THE TRAINING AND JUDGEMENT OF THE INSPECTOR.

SOLUTION - AUTOMATE THE ANALYSIS OF X-RAY RESULTS, AND PROVIDE DEPTH PERSPECTIVE BY PARALLEL OR HOLOGRAPHIC TECHNIQUES

MMT FIVE YEAR PLAN  
RCS DRCMT 126

FUNDING (\$000)

PRIOR 80 81 82 83 84  
-----

COMPONENT -- X-RAY AND N-RAY

(CONTINUED)

(3244) TITLE - NEUTRON BOMBARDMENT NONDESTRUCTIVE TESTING

277

PROBLEM - FLUX AND LUBRICANTS ARE THE MOST FREQUENT CONTAMINANTS FOUND IN COMPONENT PARTS, SEALED ELECTROMECHANICAL DEVICES, AND SEALED ONE-SHOT DEVICES. ORGANICS ARE NOT FOUND BY X-RAY INSPECTION DUE TO THEIR LOW X-RAY SCATTER OF THEIR ELEMENTS.

SOLUTION - AN EFFECTIVE LOW-COST PER ITEM NEUTRON RADIOGRAPHIC TELEVISION SYSTEM CAN BE USED FOR DETECTING ORGANIC CONTAMINANTS. THIS CAN BE DONE BY USING A SUB-CRITICAL ATOMIC PILE TO PRODUCE A WELL COLLIMATED THERMAL NEUTRON FLUX.

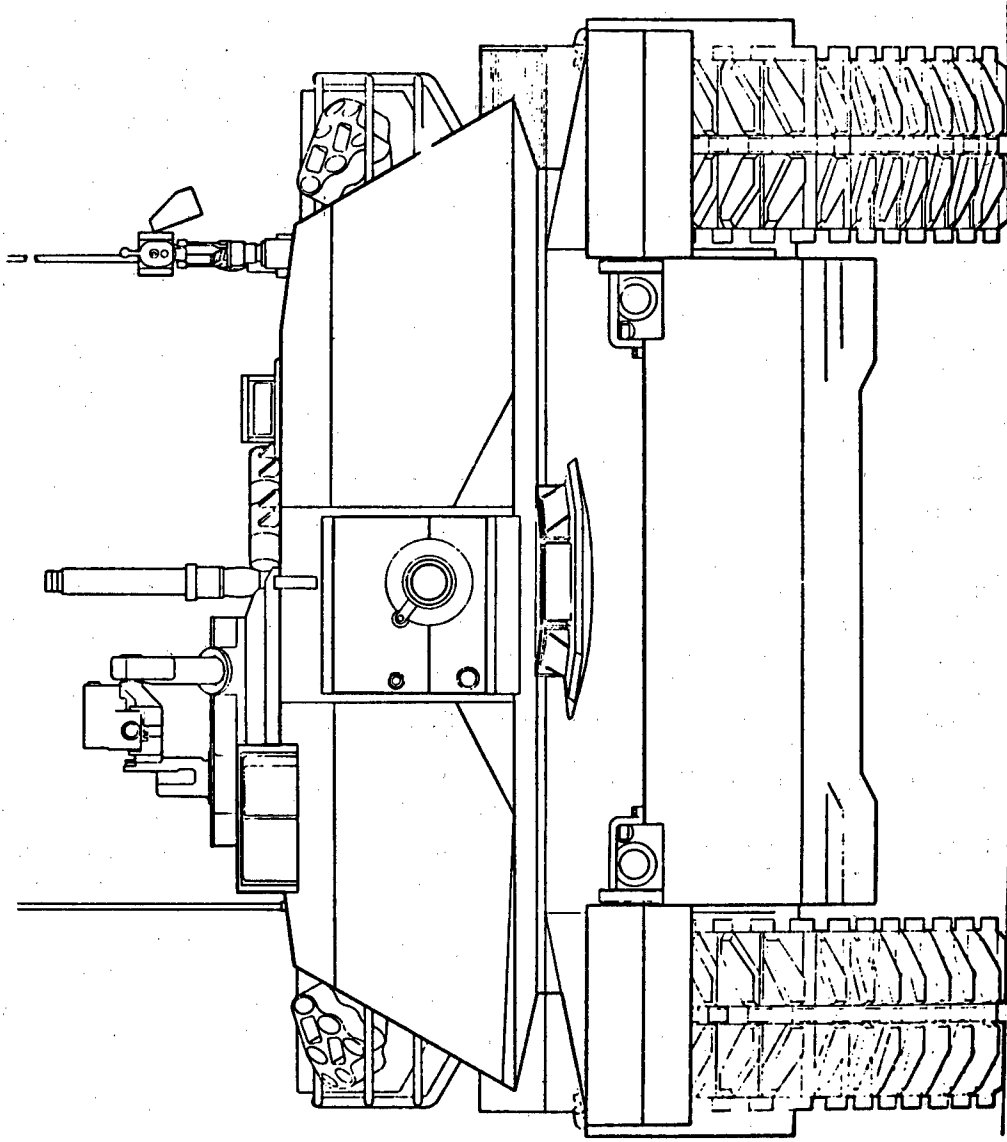

TANK-AUTOMOTIVE COMMAND  
(TACOM)

<u>CATEGORY</u>	<u>PAGE</u>
Armor -----	204
Body/Frame -----	206
Drive System -----	208
General -----	211
Suspension System -----	213
Track -----	215

## US ARMY TANK-AUTOMOTIVE COMMAND

### (TACOM)

The US Army Tank and Automotive Command was recently formed from the resources of the US Army Tank and Automotive Research and Development Command (TARADCOM) and the US Army Tank and Automotive Readiness Command (TARCOM). It is located in Warren, MI, has the mission of developing, acquiring, and fielding tracked and wheeled military combat, tactical, and general purpose vehicles. The mission is worldwide in scope and includes among its customers all of the US military services, and friendly foreign nations. The production base for mission items is made up of both private and government-owned contractor-operated facilities. MMT efforts are accomplished partially in-house and partially out-of-house. The TACOM MMT program is separated into six categories: armor, general, drive system, track, suspension, and vehicle body.

The main requirements placed on TACOM today in the field of armor are to increase the ballistic tolerance of conventional armor while reducing its overall weight, and develop new lightweight armor for the high speed, high survivability vehicles which are currently being evaluated in field tests. To meet these requirements, the Command is emphasizing Electro-Slag Remelt (ESR) steel armor, combination type armor and the application of spall suppressive armor to the interior walls of combat vehicles to reduce the overall ballistic threat. To pursue these new armor developments, it will be necessary to have commercially available joining processes so that these new armors can be used cost effectively in production. TACOM has established several MMT projects. Areas covered include joining ESR steel armor, welding complex alloys and shapes by laser, identifying electron beam welding applications, and optimizing welding procedures, and ultrasonic inspection of welds.

Other areas of interest in armor are fabrication techniques for expendable plastic decoy tanks, production procedures for the application of color-changing coatings, materials and coatings to reduce the efficiency of tracking devices, and the use of CAM in hull fabrication.

In general support of combat and tactical vehicles, TACOM is actively pursuing manufacturing technology in various areas. Projects are included for non-corrosive materials, chemical joining techniques, use of advanced microprocessors and multiplexing, high speed machining, and flexible machining pilot lines for batch production. Several projects are also proposed for the CAM area; these include a new machinery and equipment data base, computer simulation of production, application of adaptive control technology to vehicle components, and extension of CAD/CAM principles to spare parts manufacture.

The major requirements for propulsion and track are to develop production techniques to manufacture propulsion and drive systems for the XM1, XM2, XM3 and future tracked and non-tracked combat and tactical vehicles. Fabrication and joining are of major concern. TACOM is actively pursuing production development of advanced casting techniques for integrally cast compressors, automated assembly line welding techniques, compliant joints to join metals and non-metals, and automated laser machining of complex machine alloys. Life cycle costs for various tactical and combat vehicles can be significantly increased by eliminating premature failure or reduced service life of components due to corrosion and deterioration of material during the normal life cycle. To support this area, TACOM is endeavoring to bring on line ceramic reinforced combustors.

The track and suspension category is constantly caught in the technical dilemma of producing more advanced systems to meet the ever increasing demands of higher performance in more adverse terrains while maintaining the overall reliability and maintainability of the system at or near current system costs. To achieve these objectives, the track area, as with the other categories, has been sub-divided into major thrust areas for better visibility and management control. These areas are general, rubber pads, shoes, track sprockets, wedges and suspension components. In these areas the general thrusts have been to introduce production techniques for metal matrix composites, non-metallic matrix composites, advanced rubber compounds, new rubberization systems, advance elastomeric compounds, lightweight castings, hard surface coatings and powder metallurgy.

In body/frame, the main thrusts are the conservation of fuel and material. To meet these requirements the objective is to reduce the overall weight of the vehicle, to increase its payload, and lower the life cycle cost of the systems by reducing the corrosion and degradation of the materials of construction. Here the main areas of concern are coatings, lightweight/composite structures, miscellaneous components, structural members, suspension systems, and seats and fuel tanks. Within these areas, work will be accomplished in elastic reservoir molding of reinforced trailer module bodies to reduce weight and costs, rapid curing automotive paints, new fungicidal paints acceptable to the FDA, automated and computer controlled processes for joining metals with adhesives, plastic cab tops, maintenance free batteries with high impact resistance and non-corrosive, lightweight non-structural tactical vehicle components.

TARADCOM

C O M M A N D F U N D I N G S U M M A R Y  
(THOUSANDS)

CATEGORY	FY80	FY81	FY82	FY83	FY84
-----	----	----	----	----	----
ARMOR	601	1291	2495	5150	4825
BODY/FRAME	75	410	327	1220	1500
DRIVE SYSTEM	237	350	1910	2760	1320
GENERAL	2217	3087	7380	9350	10250
SUSPENSION SYSTEM	0	497	625	600	870
TRACK	0	375	450	525	100
	----	----	----	----	----
TOTAL	3130	6010	13187	19605	18865

MMT FIVE YEAR PLAN  
RCS DRCMT 126

\*\*\*\*\*  
\* C A T E G O R Y \*  
\*-----\*  
\*ARMOR\*  
\*\*\*\*\*

FUNDING (\$000)

PRIOR 80 81 82 83 84  
-----

COMPONENT -- GENERAL

(4577) TITLE - ATTACHMENT OF COMBINATION ARMOR TO COMBAT VEHICLES 250 250

PROBLEM - COMBINATION ARMOR SYSTEMS PROVIDE LARGE BALLISTIC IMPROVEMENT BUT REQUIRE COMPLEX ATTACHMENT METHODS.

SOLUTION - IDENTIFY COST EFFECTIVE METHODS FOR PRODUCTION APPLICATION.

(4578) TITLE - ELECTRON BEAM WELDING FOR FERROUS COMPONENTS 375

PROBLEM - ELECTRON BEAM WELDING FOR FERROUS MATERIALS REQUIRES MODIFICATION TO ASSURE WELD QUALITY.

SOLUTION - IDENTIFY LOW COST AUTOMATED TECHNIQUES FOR APPLICATION OF ELECTRON BEAM WELDING OF FERROUS MATERIALS.

(4586) TITLE - IMPROVED SOLIDIFICATION AND SOUNDESS THICK ARMOR CASTING 967 731

PROBLEM - PRESENT CASTING TECHNIQUES NEED UPDATING IN ORDER TO EXPLOIT THE ADVANTAGE OF CASTING PROCESS.

SOLUTION - ESTABLISH IN PRODUCTION TECHNIQUES FOR CONTROLLING SOLIDIFICATION RATES IN MOLDS TO IMPROVE PROPERTIES AND REDUCE COSTS.

(5045) TITLE - SPALL SUPPRESSIVE FOR COMBAT VEHICLES 150 86

PROBLEM - CURRENT METALLIC ARMOR DOES NOT SUPPRESS FLYING SHRAPNEL WITHIN THE VEHICLE CREW COMPARTMENT.

SOLUTION - ESTABLISH METHODS OF APPLYING SPALL SUPPRESSIVE ARMOR TO THE INTERIOR WALLS OF COMBAT VEHICLES.

(5065) TITLE - ADVANCED TECHNOLOGY SURVEILLANCE COUNTERMEASURES MATERIALS 100 250

PROBLEM - USE OF MATERIALS WHICH WILL DEFEAT SURVEILLANCE MEASURES HAS NOT BEEN EXPLOITED IN PRODUCTION.

SOLUTION - PRODUCTION TECHNIQUES ARE NEEDED TO ASSURE SUFFICIENT QUALITY TO PERFORM SATISFACTORILY.

(5088) TITLE - HIGH-POWER ELECTRON BEAM WELDING IN AIR 250 300

PROBLEM - USE OF ELECTRON BEAM HAS NOT BEEN EXPLOITED.

SOLUTION - ESTABLISH PROCEDURES UTILIZING THIS NEW PROCESS FOR RAPID ECONOMICAL JOINING OF ARMOR MATERIALS.

(5094) TITLE - ALLOY AND ARMOR STEELS TREATED WITH RARE EARTH ADDITIVES 48 500

PROBLEM - ARMOR STEELS UTILIZED CONVENTIONAL PEOXIDIZING AND SCAVENGING PROCESSES IN STEEL MAKING.

SOLUTION - ESTABLISH TECHNIQUES TO TREAT STEELS WITH RARE EARTH ADDITIONS.

PRIOR 80 81 82 83 84  
-----

COMPONENT -- GENERAL	459	700	600
(6038) TITLE - HIGH DEPOSITION WELDING PROCESSES FOR ARMOR			
PROBLEM - WELDING IS LABOR INTENSIVE AND HIGH COST IT IS A MAJOR COST DRIVER IN ARMOR VEHICLE MANUFACTURE.			
SOLUTION - HIGH DEPOSITION WELDING PROCESSES WILL PERMIT WELDING TO BE ACCOMPLISHED MORE RAPIDLY THUS REDUCING MANPOWER REQUIREMENTS AND INCREASING PRODUCTIVITY.			
COMPONENT -- HULL/BODY	255	85	
(4392) TITLE - JOINING DISSIMILAR METALS			
PROBLEM - CURRENT ARMOR DESIGNS ONLY EMPLOY ONE TYPE OF METAL FOR WELDING.			
SOLUTION - BI-METAL INSERTS WILL BE INVESTIGATED? COMBINATION MECHANICAL AND WELD JOINTS WILL ALSO BE STUDIED.			
(5014) TITLE - FOUNDRY CASTING PROCESSES USING FLUID FLOW + THERM ANALYS	975	50	300 150
PROBLEM - FOUNDRY CASTING PROCESSES ARE WASTEFUL OF RAW MATERIALS AND ENERGY.			
SOLUTION - OPTIMIZE CASTING PROCESSES BY DIGITAL COMPUTER ANALYSIS OF ADVANCED FLUID FLOW AND THERMAL ACTIVITY.			
(6053) TITLE - WELDING SYSTEMS INTEGRATION	510	500	500 500
PROBLEM - OF ALL METAL WORKING PROCESSES EMPLOYED IN TRACKED COMBAT VEHICLES MANUFACTURING, WELDING IS THE MOST LABOR INTENSIVE AND AFTER MACHINING, THE MOST COSTLY. AUTOMATION WHICH COULD REDUCE THESE COSTS IS AS YET AN UNACHIEVED GOAL.			
SOLUTION - UNDERTAKE A COORDINATED PROGRAM TO INTEGRATE EXISTING EXPERTISE AND TECHNOLOGY TO ADDRESS ONE APPLICATION (XMI HULL). EXPERTISE WILL BE IN AREAS OF WELDING PROCESS CONTROL, SENSORY TECHNOLOGY, STRESS ANALYSIS, AND COMPUTER CONTROL.			
(6068) TITLE - PERMANENT SPLIT MOLD FOR NET SHAPE STEEL CASTINGS		500	300
PROBLEM - MANY PARTS, UNIQUE TO THE ARMY NEEDS, ARE FORGINGS WHICH REQUIRE EXPENSIVE AND EXTENSIVE MACHINING TO FINISH.			
SOLUTION - PERMENT MOLD CASTING PROCESS IS ABLE TO PRODUCE CLOSE TOLERANCES, THEREBY REDUCING OR ELIMINATING MANY COSTLY FINISHING OPERATIONS.			
(6073) TITLE - ADAPTION AND AUTOMATION OF ACOUSTIC EMISSION WELD MONITORING			100
PROBLEM - IN PROCESSES OF HEAVY WELDING SUCH AS WITH ARMOR, RADIOGRAPHIC INSPECTION METHODS ARE COSTLY AND NOT TOTALLY RELIABLE			
SOLUTION - ACOUSTIC SENSORS, USED WITH THE WELDING EQUIPMENT, MONITOR WELD QUALITY AS THE WELD IS MADE. REPAIRS MAY BE MADE IMMEDIATELY.			

COMPONENT -- TURRETS/CUPOLA

(6059) TITLE - FVS COMBAT VEHICLE

515 1210 2000 3000

PROBLEM - COMPLEX WELDED ARMOR AND STRUCTURAL SHAPES ARE COSTLY AND TIME CONSUMING. ITEMS SUCH AS TURRETS HAVE RESIDUAL STRESSES WHICH CREATE SUBSEQUENT MACHINING PROBLEMS.

SOLUTION - DEVELOP THE CAPABILITY TO CAST LARGE BALLISTIC STRUCTURES FROM A206 ALUMINUM.

\*\*\*\*\*  
\* C A T E G O R Y \*  
\*-----\*  
\*BODY/FRAME \*  
\*\*\*\*\*

COMPONENT -- COATING

(5047) TITLE - ENVIRONMENTAL COLOR ADAPTING COATINGS FOR COMBAT VEHICLES 150

PROBLEM - ARMY VEHICLE COLORS DO NOT BLEND WITH EVERY TERRAIN AND/OR ENVIRONMENTAL CONDITION.

SOLUTION - ESTABLISH PROCESS FOR APPLICATION OF COATINGS WHICH WILL CHANGE COLOR TO BLEND INTO ANY ENVIRONMENT.

(5068) TITLE - NEW ANTI-CORROSIVE MATERIALS AND TECHNIQUES 30 300 150 150

PROBLEM - METALLIC COMPONENTS ARE DETERIORATED BY THE ENVIRONMENT.

SOLUTION - ESTABLISH TECHNIQUES OF ECONOMICALLY APPLYING ANTI-CORROSIVE MATERIAL COATINGS TO THE COMPONENTS OF THE TACTICAL VEHICLE FLEET.

(6012) TITLE - PRODUCTION TECHNIQUES FOR THE APPLICATION NEW NONTOXIC PAINT 100 250

PROBLEM - THE OLD PAINT WITH METAL ANTI-FUNGICIDES HAVE BEEN DISAPPROVED BY THE FDA.

SOLUTION - DEVELOP NEW METHODS FOR APPLYING THE NEWLY DEVELOPED PAINTS.

COMPONENT -- FUEL TANKS

(6071) TITLE - PASSIVE EXPLOSION SUPPRESSION SYSTEM 300

PROBLEM - FUEL CONTAINERS IN A VEHICLE ARE A CRITICAL HAZARD IF ENEMY FIRE HITS THE VEHICLE. SERIOUS FIRES CAN RESULT.

SOLUTION - TECHNOLOGY HAS PROVIDED SEVERAL POSSIBLE ANSWERS TO THIS PROBLEM, AND THESE WILL BE EVALUATED AND APPLIED AS A SOLUTION.

FUNDING (\$0000)

PRIOR 80 81 82 83 84  
-----

COMPONENT -- LIGHTWEIGHT/COMPOSITE STRUCTURES

200

(5039) TITLE - INSULATED PLASTIC ENVIRONMENTAL TRAILER MODULES (ERM)

PROBLEM - MINIMUM EFFORT WAS EXERTED TO DEVELOP TECHNIQUES TO UTILIZE ALL PLASTIC, NON-STRUCTURAL VEHICLE BODIES.

SOLUTION - ESTABLISH THE FEASIBILITY OF USING ELASTIC RESERVOIR MOLDING REINFORCED BODIES FOR TRAILER MODULES.

300

(5042) TITLE - MANUFACTURING TECHNIQUES FOR NON-METALLIC TOTAL VEHICLES

PROBLEM - CURRENT NON-STRUCTURAL VEHICLE BODIES MADE FROM METALS ARE EXCESSIVE IN WEIGHT AND TEND TO CORRODE.

SOLUTION - ESTABLISH FEASIBILITY OF MOLDING A VEHICLE BODY USING A MINIMUM OF PARTS.

110

(6000) TITLE - LIGHTWEIGHT TILT-UP HOOD/FENDER ASSEMBLY

PROBLEM - CURRENT HOOD/FENDER ASSEMBLY MADE FROM STEEL STAMPINGS ARE TOO HEAVY FOR ONE MAN TO LIFT.

SOLUTION - REDUCE WEIGHT BY MANUFACTURING ITEMS FROM LIGHTWEIGHT FORMABLE PLASTIC.

300

(6058) TITLE - EXPLOSIVE BONDING OF COMPOSITE MATERIALS

PROBLEM - REQUIREMENTS TO BOND ALTERNATE PLIES OF STEEL AND ALUMINIUM MAY BE MET ONLY BY CUMBERSOME, EXPENSIVE AND SLOW PROCESSES.

SOLUTION - EXPLOSIVE BONDING BONDS STEEL AND ALUMINIUM QUICKLY, RELIABLY, AND CAN BE APPLIED TO ARMOR FABRICATION.

COMPONENT -- MISC COMPONENTS

300 30

(5019) TITLE - TACTICAL VEHICLE STORAGE BATTERY

PROBLEM - THE MAJOR CAUSE OF TACTICAL VEHICLE BATTERY FAILURE IS BATTERY CONTAINER BREAKAGE.

SOLUTION - PROVIDE NEW HIGH IMPACT PLASTIC CONTAINER TO INCREASE FIELD PERFORMANCE REQUIREMENTS AND TO ACCOMMODATE THE MAINTENANCE FREE CONCEPT ALREADY RELEASED IN LARGER MILITARY BATTERY SIZES.

60 15

(5067) TITLE - PLASTIC BATTERY BOX

PROBLEM - METALLIC BATTERY BOXES ARE SUBJECT TO CORROSION, THEREBY, DAMAGING THE VEHICLE.

SOLUTION - ESTABLISH PRODUCTION TECHNIQUES TO USE NON-CORROSIVE NON-METALS.

COMPONENT -- MISC COMPONENTS

(CONTINUED)

(5069) TITLE - THREADED FASTENER-LOCKING ADHESIVES AND SEALANTS 120

PROBLEM - VIBRATION AND SHOCK IN MILITARY VEHICLE OPERATION DEFEATS MANY OF THE MOST EFFICIENT LOCKING MEANS FOR THREADED FASTENERS.

SOLUTION - DETERMINE AND APPLY OPTIMIZED AVAILABLE THREAD DEALING COMPONENTS FOR USE IN VEHICLE MANUFACTURE.

(6042) TITLE - SPARE PARTS MANUFACTURE BY CAD/CAM 250

PROBLEM - SPARE PARTS FOR TRACKED COMBAT VEHICLES ARE PROCURED IN SMALL QUANTITIES AND IN A GENERALLY RANDOM MANNER. THIS PROCUREMENT PRACTICE RESULTS IN HIGH COSTS AND SHORTAGES DUE TO EXTENDED DELIVERY SCHEDULES.

SOLUTION - THE ARMY HAS AVAILABLE AND IS DEVELOPING A NUMBER OF CAD/CAM PROGRAMS DIRECTED TO THE MANUFACTURE OF ITEMS FOR INITIAL ACQUISITION. THE RESULTS OF THESE PROGRAMS WILL BE ADDRESSED TO SPARE PARTS ACQUISITION TO PROVIDE IMPROVED PROCUREMENT.

(6064) TITLE - ADHESIVES FOR TACTICAL VEHICLE ATTACHMENTS 250 300

PROBLEM - THE FEASIBILITY OF USING ADHESIVES IN PLACE OF WELDING HAS BEEN ESTABLISHED, BUT WORK NEEDS TO BE DONE TO ESTABLISH OPTIMUM ADHESIVES AND CONDITIONS FOR ITS APPLICATION IN THE PRODUCTION ENVIRONMENT.

SOLUTION - ESTABLISH A PROCESS FOR APPLYING ADHESIVE BONDING TO THE ATTACHMENT OF ITEMS TO ARMORED VEHICLES.

COMPONENT -- STRUCTURAL MEMBERS

(4579) TITLE - INDUSTRIAL PRACTICES FOR WELDING CONSTRUCTIONAL ALLOY STEELS 150

PROBLEM - A WIDE VARIETY OF HIGH STRENGTH CONSTRUCTIONAL ALLOYS STILL WILL BE USED IN GREATER QUANTITIES TO MEET WEIGHT REQUIREMENTS.

SOLUTION - DOCUMENT RECOMMENDED WELDING PRACTICES AND PROCEDURES TO IDENTIFY SIGNIFICANT FACTORS AFFECTING PRODUCTION QUALITY FOR THE VARIOUS MATERIALS AND EQUIPMENT.

(6067) TITLE - AUTOMATED PROTOTYPE FRAME WELDING 77

PROBLEM - THE WELDING OF SPECIALIZED TRUCK AND TRAILER FRAMES BY THE MANUAL METHOD IS TIME CONSUMING AND COSTLY.

SOLUTION - ESTABLISH A UNIVERSAL FIXTURE THAT WILL USE AUTOMATIC WELDING PROCEDURES.

\*\*\*\*\*  
\* C A T E G O R Y \*  
\*-----\*  
\*DRIVE SYSTEM \*  
\*\*\*\*\*

COMPONENT -- ENGINE

(5053) TITLE - MANUFACTURE OF ENGINE COMPONENTS OF CERAMIC

550 550

PROBLEM - FABRICATION OF HIGH EFFICIENCY, HIGH TEMPERATURE DIESEL ENGINES REQUIRES ADVANCED MATERIALS. ENGINES FABRICATED WITH CERAMIC COMPONENTS HAVE BEEN DEMONSTRATED IN R+D BUT MANUFACTURING METHODS FOR SERIAL PRODUCTION COMPONENTS ARE LACKING.

SOLUTION - RECENT RESEARCH EFFORTS INDICATE THAT ENGINE COMPONENTS FROM HIGH STRENGTH STRUCTURAL CERAMICS (SILICON NITRIDE, SILICON CARBIDE) ARE FEASIBLE. THIS EFFORT WILL ESTABLISH QUANTITY PRODUCTION OF CERAMIC COMPONENTS OF CONSISTENT QUALITY.

(5085) TITLE - PROD TECH FOR FAB OF TURBINE ENGINE RECUPERATOR

1318 237

PROBLEM -- CURRENT METHOD REQUIRES A LARGE NUMBER OF WELDS TO FABRICATE COMPONENT.

SOLUTION - ESTABLISH PROCEDURE UTILIZING A LASER BEAM TO GREATLY INCREASE WELDING SPEED.

(5097) TITLE - INTEGRALLY CAST LOW COST COMPRESSOR

717 350

PROBLEM - TURBINE BLADES AND DISCS MUST HAVE ADEQUATE LOW AND HIGH CYCLE FATIGUE PROPERTIES. AXIAL COMPRESSOR STAGES ARE DESIGNED AS SEPARATELY BLADED ASSEMBLIES.

SOLUTION - INTEGRALLY CAST THE AXIAL COMPRESSOR STAGES AND THE CENTRIFUGAL ROTOR TO ELIMINATE MANY COSTLY MACHINING OPERATIONS.

(6008) TITLE - AUTOMATED COMPUTER CONTROL LASER MACHINING

250

PROBLEM - CONVENTIONAL MACHINING OF DIFFICULT TO MACHINE MATERIALS IS VERY EXPENSIVE. RAPID TOOL WEAR AND LOCALIZED HEATING OF THE WORKPIECE IMPACT REMOVAL RATES AND METALLURGICAL CHARACTERISTICS.

SOLUTION - THIS PROGRAM WILL DEVELOP TECHNIQUES FOR LASER MACHINING BY NUMERICAL CONTROL.

(6018) TITLE - JOINING OF ATTACHMENTS ON CERAMICS

100

PROBLEM - CURRENT METHOD OF JOINING METALS TO CERAMIC JOINTS ARE NOT RELIABLE AND HAVE POOR LIFE.

SOLUTION - INVESTIGATE USE OF JOINTS THAT ARE COMPLIANT OR USE INTERMEDIATE CONNECTING PHASE.

(6019) TITLE - GRAIN BOUNDARY IMPROVEMENT PROCESSING FOR CERAMICS

100

PROBLEM - EFFECT OF HIGH TEMPERATURE ON CERAMICS GRAIN BOUNDARIES LIMIT THEIR APPLICATION.

SOLUTION - UPSCALE DEVELOPED TECHNIQUES FOR DEVELOPING A NONGLASS BOUNDARY OR ELIMINATE THE GRAIN BOUNDARY PHASE.

MMT FIVE YEAR PLAN  
RCS DRCMT 126

FUNDING (\$000)

PRIOR 80 81 82 83 84  
-----

COMPONENT -- ENGINE

(CONTINUED)

(6020) TITLE - PRODUCTION OF REINFORCED CERAMIC COMBUSTORS 300 200

PROBLEM - TECHNIQUE FOR LARGE SCALE PRODUCTION OF COMBUSTORS NOT AVAILABLE. THESE COMBUSTORS IMPROVE ENGINE PERFORMANCE GREATLY.

SOLUTION - UPSCALE LABORATORY PROVEN TECHNIQUE FOR FABRICATING COMBUSTOR FOR PRODUCTION.

(6055) TITLE - PRODUCTION OF IMPROVED ANTI-CORROSIVE MATERIALS 250 200

PROBLEM - TO INCREASE THE EFFICIENCY OF TURBINE ENGINES CREEP RESISTANT NON-CORRODING, HIGH TEMPERATURE STRENGTH MATERIALS ARE REQUIRED. PRESENTLY EXPENSIVE METALLIC SUPERALLOYS AND CERAMICS ARE BEING USED.

SOLUTION - IN MECHANICAL ALLOYING METAL POWDERS ARE COLD WELDED IN HIGH-ENERGY MILLS. THE PROPERTIES OF THESE ALLOYS ARE SUPERIOR OVERALL TO THE PRESENTLY USED MATERIALS. MANUFACTURING TECHNIQUES FOR MASS PRODUCTION WILL BE ESTABLISHED.

(6056) TITLE - SIMPLIFIED TEST EQUIP FOR INT COMB ENGINES(STE/ICE) 305 320

PROBLEM - SUITABLE TRANSDUCERS AND SENSORS ARE NOT READILY AVAILABLE FOR INSTALLATION ON MILITARY VEHICLES FOR BUILT-IN DIAGNOSTICS.

SOLUTION - TRANSDUCERS ARE TO BE DEVELOPED TO FULFILL THE NEEDS FOR DIAGNOSTIC CAPABILITY.

(6072) TITLE - LASER VIBRATION DEPOT INSPECTION SYSTEM 400 400

PROBLEM - FOR DEPOT OVERHAUL WORK IN POWER TRAIN COMPONENTS, NO DEVICE IS ON HAND FOR DIAGNOSING CAUSES OF VIBRATION, AND THE RESULTANT DAMAGE TO ENGINES.

SOLUTION - LASER VIBRATION SENSING DEVICES CAN BE DEVELOPED FOR OVERHAUL INSPECTION DIAGNOSTICS. THEY HAVE BEEN PROVEN IN SIMILAR APPLICATIONS.

COMPONENT -- TRANSMISSION

(5005) TITLE - COLD FORGED GEARS TO DRAWING TOLERANCES 300 300

PROBLEM - MACHINING AND OTHER PROCESSES ADD COST TO THE FINISHED COMPONENT.

SOLUTION - ESTABLISH A MFG PROCESS TO RESULT IN A FINISHED GEAR TO DRAWING TOLERANCES FROM BAR STOCK AT AMBIENT TEMPERATURES.

COMPONENT -- TRANSMISSION

(CONTINUED)

(5024) TITLE - GEAR DIE DESIGN AND MFG UTILIZING COMPUTER TECHNOLOGY (CAM) 405 640

PROBLEM - THE CONTROL OF DIMENSIONAL TOLERANCES OF FORGED BEVEL GEARS PRESENTS A UNIQUE PROBLEM SINCE THESE GEARS ARE NOT MFG. TO THEORETICAL EQUATIONS. THE BEVEL GEAR IS NOT DEFINED DIMENSIONALLY BUT IS PRESENTED AS REQUIREMENTS FOR TOOTH BEARING PATTERNS.

SOLUTION - THIS PROGRAM WILL ELIMINATE THE CURRENT TRIAL AND ERROR METHODS BY UTILIZING CAD/CAM METHODS AND INTERACTIVE GRAPHICS TECHNIQUES. EXCESSIVE SCRAP, UNEXPECTED DIE WEAR AND BREAKAGE, AND THE HIGH COST OF FORGING DIES WILL BE ADDRESSED.

(5083) TITLE - UPSCALING OF ADVANCED POWDER METALLURGY PROCESSES 986 300

PROBLEM - POWDER METALS PROCESSES HAVE NOT BEEN UTILIZED IN LARGE COMPONENTS

SOLUTION - EST PROCESSES WHICH PRODUCE HIGH DENSITY HIGH STRENGTH LARGE COMPLEX SHAPES.

(5086) TITLE - SURFACE HARDENING AND ALLOYING OF TRANS SYSTEMS WITH LASERS 170 405

PROBLEM - FLAME AND INDUCTION HARDENING IS EMPLOYED TO SURFACE HARDEN VEHICLE TRANSMISSION PARTS. THESE PROCESSES ARE INEFFICIENT.

SOLUTION - ESTABLISH PARAMETERS AND CONTROLS NEEDED FOR LASER SURFACE HARDENING

\*\*\*\*\*  
\* C A T E G O R Y \*  
\*-----\*  
\*GENERAL\*  
\*\*\*\*\*

COMPONENT -- MISCELLANEOUS

(4588) TITLE - MOLDED PLASTIC ORDNANCE ELECTRICAL CONNECTOR 100 100

PROBLEM - METALLIC SHELL ELECTRICAL CONNECTORS ARE COSTLY AND SUSCEPTIBLE TO CORROSION AND OTHER PROBLEMS.

SOLUTION - DEVELOP A MEANS OF MANUFACTURING CONNECTORS WITH PLASTIC REPLACING METAL SHELLS.

(5016) TITLE - IMPROVED HIGH STRENGTH ALUMINUM COMPONENTS BY MECH TREATMENT 200 200

PROBLEM - COMMERCIALY AVAILABLE HIGH STRENGTH ALUMINUM ALLOYS NEED IMPROVEMENT IN DUCTILITY AND FRACTURE TOUGHNESS.

SOLUTION - ESTABLISH PRODUCTION PROCESSES UTILIZING ADVANCES IN BOTH METAL SOLIDIFICATION AND THERMAL MECHANICAL WORKING OF ALUMINUM ALLOYS.

COMPONENT -- MISCELLANEOUS

(CONTINUED)

(5082) TITLE - FLEXIBLE MACHINING SYSTEM PILOT LINE FOR TCV COMPONENT 440 880 880 750 500

PROBLEM - PARTS FOR TRACKED COMBAT VEHICLES ARE TYPICALLY NOT MANUFACTURED IN LARGE QUANTITIES. BECAUSE OF THIS, MASS PDN TECHNOLOGIES THAT RESULT IN LOWER PDN COSTS ARE NOT USED.

SOLUTION - THE ADVANTAGES OF MASS PDN CAN BE REALIZED IN PRODUCING MEDIUM QUANTITY SIZE LOTS BY A CONCEPT KNOWN AS, FLEXIBLE MACHINING SYSTEMS. THIS PROJECT WILL ADVANCE THE FMS TECHNOLOGY MAKING IT FEASIBLE TO UTILIZE FMS FOR THE MFG OF ARMY MATERIEL.

(5090) TITLE - IMPROVED AND COST EFFECTIVE MACHINING TECHNOLOGY 380 249 290 150

PROBLEM - MACHINE DATA ON NEWER MATERIALS AND NEW REMOVAL RATES ARE NOT ESTABLISHED.

SOLUTION - ESTABLISH DATA WHEREAS THE NEW MACHINING EQUIPMENT MAY BE UTILIZED WITH MAXIMUM EFFICIENCY.

(5093) TITLE - MANUFACTURING METHODS FOR HIGH SPEED MACHINING FERROUS ALLOY 450 550 500

PROBLEM - FAST CHIP REMOVAL FOR FERROUS ALLOYS HAVE NOT BEEN ESTABLISHED FOR PRODUCTION.

SOLUTION - ESTABLISH FAST CHIP REMOVAL FOR PRODUCTION CONDITIONS.

(6014) TITLE - AUTOMATED PRODUCTION OF MULTIPLEXING NETWORKS FOR COMBAT VEH 200

PROBLEM - ADVANCED TECHNIQUES FOR ELECTRICAL POWER DISTRIBUTION AND VEHICLE CONTROL WILL USE ADVANCED MICROPRESSURES AND MULTIPLEXING AND INTRODUCE NEED FOR NEW ASSEMBLY TECHNIQUE.

SOLUTION - COMPUTER AIDED DESIGN AND MANUFACTURING WILL BE APPLIED TO ASSEMBLY OF THE COMPLEX ELECTRONIC SYSTEMS.

(6025) TITLE - MANUFACTURING LASER FACILITY 1080 1000 1000

PROBLEM - THE FEASIBILITY OF USING LASERS FOR METAL PROCESSING IS ESTABLISHED. IMPLEMENTATION IS IMPEDED BY THE COST OF FACILITIZATION.

SOLUTION - ESTABLISH A FACILITY TO IMPLEMENT LASER TECHNOLOGY IN PRODUCTION.

(6030) TITLE - COMPUTER SIMULATION OF TCV MANUFACTURING PROCESSES 250

PROBLEM - THE LONG LEAD TIMES REQUIRED IN THE MATERIAL ACQUISITION PROCESS OF TRACKED COMBAT VEHICLES (TCV) DO NOT ALLOW COMPONENTS TO REFLECT THE LATEST TECHNOLOGIES. THIS LEADS TO DELAYS AND EXCESSIVE COSTS.

SOLUTION - SIMULATING THE MANUFACTURING PROCESS DURING THE VEHICLE DEVELOPMENT PHASE WILL IDENTIFY TOOLING, OPTIMUM MANUFACTURING PROCESSES, OPTIMUM PRODUCTION LINE, AND POTENTIAL PRODUCTION PROBLEMS. IT WILL ASSIST INNOVATION AND PROVIDE FOR ACCURATE PLANNING.

PRIOR 80 81 82 83 84  
-----

COMPONENT -- MISCELLANEOUS

(CONTINUED)

(6041) TITLE - APPLICATION OF ADAPTIVE CONTROL

750 750

PROBLEM - SENSORS WHICH RECOGNIZE AND SIGNAL PHENOMENAL CHANGES HAVE BEEN DEVELOPED AND DEMONSTRATED. APPLICATION OF THESE TO ADAPTIVE CONTROL CAN ADVANCE AUTOMATION TO THE LEVEL OF "PUSH BUTTON" FACTORIES, BUT LITTLE OR NOTHING HAS BEEN DONE IN THIS AREA.

SOLUTION - STATE-OF-THE-ART SENSORS WILL BE ADAPTED TO A CNC MACHINING CENTER TO ADVANCE ITS PERFORMANCE BEYOND PRESENT LEVELS OF EFFICIENCY. THIS WILL PROVIDE A PROVEN CAPABILITY WHICH CAN BE EMPLOYED ON OTHER MACHINES.

(6054) TITLE - ADVANCED METROLOGY SYSTEMS INTEGRATION

350 500 500

PROBLEM - THE METROLOGY METHODS USED IN MILITARY VEHICLE MANUFACTURE, IN GENERAL, EMPLOYS CONTACT GAUGES MANUALLY EMPLOYED. THIS REPRESENTS A SUBSTANTIAL PART OF THE COST OF OUR MILITARY VEHICLES.

SOLUTION - NON-CONTACT, IN-PROCESS GAUGING (ELECTRO-OPTICAL AND LASER) WILL BE ADAPTED TO A VEHICLE MACHINING OPERATION. SOLID PHOTOGRAPHY WILL BE ADAPTED TO MEET THE MEASURING REQUIREMENTS OF COMPONENTS SUCH AS TURBINE BLADES.

(6057) TITLE - XM1 COMBAT VEHICLE

1088 1567 4950 5500 7000

PROBLEM - MATERIALS AND MANUFACTURING PROCESSES EMPLOYED IN THE MFG OF THE XM1 CAN BE IMPROVED BY INCORPORATING NEW TECHNOLOGIES TO THE CURRENT SYSTEM. THIS WILL ENABLE THE XM1 TO BE MANUFACTURED MORE ECONOMICALLY.

SOLUTION - IMPROVE PROCESSES FOR XM1 MFG. THESE INCLUDE THERMAL CUTTING, AUTOMATED METALLIZING, BI-CAST HP TURBINE NOZZLES, RSR NICKEL BASE SUPEK ALLOYS, MONOCRYSTAL ALLOYS, CERAMIC COMBUSTORS, THERMALLY ASSISTED MACHINING, ET AL.

\*\*\*\*\*  
\* C A T E G O R Y \*  
\*-----\*  
\*SUSPENSION SYSTEM \*  
\*\*\*\*\*

COMPONENT -- ROAD WHEELS

(4559) TITLE - PRESSURE CASTING TECHNIQUES FOR ALUMINUM COMPONENTS

250

PROBLEM - ALUMINUM CASTINGS REQUIRE GATINGS AND RISERS WHICH UTILIZE LARGE AMOUNTS OF MATERIAL WHICH HAVE TO BE REMOVED FROM THE CASTINGS AND USED AS SCRAP REMELT. THIS CONTRIBUTES TO INCREASED COSTS OF COST ITEMS.

SOLUTION - ESTABLISH MANUFACTURING PROCESSES UTILIZING LOW PRESSURE CASTING TECHNIQUES, THEREBY ELIMINATING THE NEED FOR EXCESS GATING AND TOTALLY ELIMINATING RISERS.

COMPONENT -- ROAD WHEELS

(CONTINUED)

350

(6050) TITLE - BLAST HARDENED ROAD WHEELS FOR TRACKED COMBAT VEHICLES

PROBLEM - COMPOSITE ROAD WHEELS ARE MAJOR COMPONENTS FOR BLAST HARDENED TCV SUSPENSION SYSTEMS. CURRENT HAND FABRICATION WILL HAVE TO BE SCALED-UP. MAIN PROBLEMS ARE ENCAPSULATING WHEELS IN POLYURETHANE ELASTOMER AND AUTOMATED FABRICATION OF RINGS AND RIMS.

SOLUTION - RINGS AND RIMS WILL BE WOUND ON MULTIPLE MANDREL EQUIPMENT USING GLASS CLOTH TAPE WITH VERY ACCURATE RESIN DISTRIBUTION, CURED IN MATCHED METAL MOLDS, AND THEN THE POLYURETHANE ENCAPSULANT WILL BE INJECTED AROUND THE WHEEL ASSEMBLY AND CURED.

(6076) TITLE - AUTOMATED DEPOT INSPECTION OF ROAD WHEELS

247

COMPONENT -- SPRINGS

(6011) TITLE - SPRINGS FROM CARBON-FIBER PLASTIC-COMPOSITES

250 350

PROBLEM - STEEL SPRINGS FOR TACTICAL VEHICLES ARE HEAVY AND SUBJECT TO FAILURE FROM FATIGUE. CARBON FIBER COMPOSITES ARE LIGHTER AND HAVE EXCELLENT FATIGUE RESISTANCE.

SOLUTION - THE TECHNOLOGY IS KNOWN TO MANUFACTURE LEAF SPRINGS FROM CARBON-FIBER-PLASTIC COMPOSITES- HOWEVER THE TECHNIQUES FOR MASS PRODUCTION NEED TO BE DEVELOPED.

COMPONENT -- TORSION BAR/TUBE

(5002) TITLE - FABRICATING TORSION BAR SPRINGS FROM HIGH STRENGTH STEEL

150 275

PROBLEM - ENGINEERING ALLOY STEELS CAN BE HEAT TREATED TO A MAXIMUM WORKING HARDNESS WHICH REQUIRES LARGE DIAMETER BARS THEREBY INTERFERING WITH DESIGN FITS AND INCREASING WEIGHT.

SOLUTION - ESTABLISH METHODS OF FABRICATING TORSION BARS UTILIZING 300000 MINIMUM YIELD MATERIALS.

(5074) TITLE - PRODUCTION TECHNIQUES FOR COMBAT VEHICLE SUSPENSION SYSTEMS

300

PROBLEM - SUSPENSION SYSTEMS OF COMBAT VEHICLES ARE UNDERGOING A LARGE DESIGN CHANGE TO PROVIDE INCREASED MOBILITY PERFORMANCE BY UTILIZING NEWLY DEVELOPED COMPONENTS. APPLICATION OF THE ADVANCED SYSTEMS WILL INCREASE ACQUISITION COSTS.

SOLUTION - APPLY ADVANCED MANUFACTURING TECHNIQUES TO REDUCE OR PREVENT INCREASES IN THE ACQUISITION COSTS.

COMPONENT -- TORSION BAR/TUBE (CONTINUED)

(6029) TITLE - MANUFACTURING PROCESS FOR METAL MATRIX COMPOSITES 200

PROBLEM - METAL MATRIX COMPOSITES MAKE POSSIBLE COMPONENTS HAVING REDUCED WEIGHT AND INCREASED STRENGTH THE MANUFACTURING METHODS FOR PRODUCTION MUST BE DEVELOPED BY UPSCALING LAB METHODS.

SOLUTION - UPSCALE AND OPTIMIZE MANUFACTURING METHODS.

COMPONENT -- WHEELS

(5038) TITLE - NON-PNEUMATIC COMBAT TIRE FABRICATION TECHNIQUES 120

PROBLEM - PNEUMATIC TIRES ON TACTICAL VEHICLES ARE SUBJECT TO COMBAT DAMAGE.

SOLUTION - ESTABLISH PROCESSING TECHNIQUES TO ASSURE RELIABLE HIGH MOBILITY, NON-PNEUMATIC TIRES.

(6070) TITLE - TIRE PRESERVATION COATING 150 100

PROBLEM - TIRE DETERIORATION FROM AGE AND WEATHER CAUSES INTOLERABLE WASTE.

SOLUTION - PRESERVATIVE COATINGS ARE KNOWN PRODUCTS AND NEED TO BE EVALUATED AND INCORPORATED INTO THE ARMY'S INVENTORY.

\*\*\*\*\*  
\* C A T E G O R Y \*  
\*-----\*  
\*TRACK \*  
\*\*\*\*\*

COMPONENT -- RUBBER PADS

(5075) TITLE - RUBBER FOR MILITARY TRACK 200

PROBLEM - TRACK LIFE IS HELD AT ITS PRESENT LEVEL BY FAILURE OF RUBBER COMPONENTS SUCH AS BUSHINGS, PADS AND BLOCKS.

SOLUTION - ESTABLISH PRODUCTION PROCESSES FOR NEWLY DEVELOPED ELASTOMER COMPOUNDS FOR TRACKS.

COMPONENT -- SHOES

(4513) TITLE - HIGH DENSITY POWDER METAL PARTS FOR COMBAT VEHICLES 100

PROBLEM - TRACK WEDGES WEAR EXCESSIVELY REQUIRING THE TRACK TO BE ADJUSTED AND/OR THE WEDGES REPLACED FREQUENTLY.

SOLUTION - FABRICATE THE WEDGE BY COMPACTING A HIGH MANGANESE WORK HARDENABLE POWDER.

MMT FIVE YEAR PLAN  
RCS DRCMT 126

FUNDING (\$000)

PRIOR 80 81 82 83 84  
-----

COMPONENT -- SHOES

(CONTINUED)

250

(5043) TITLE - FABRICATION TECHNIQUES FOR NON METALLIC TRACK

PROBLEM - CURRENT METALLIC TRACK CONTRIBUTES A LARGE PERCENTAGE OF TOTAL VEHICLE WEIGHT.

SOLUTION - INVESTIGATE FABRICATION FEASIBILITY TO BUILD AN ALL PLASTIC COMBAT VEHICLE TRACK.

(5054) TITLE - LASER SURFACE HARDENING COMBAT VEHICLE COMPONENTS 175 175 175

PROBLEM - PRESENT METHODS OF SURFACE HARDENING INPUTS HEAT OVER LARGE SURFACE AREA.

SOLUTION - ESTABLISH LASER BEAM HARDENING PROCEDURES WITH ITS ATTENDANT FINE BEAM SMALL AREAS RAPID HEATING.

(5092) TITLE - RHEOCAST PRESSURE CASTING FOR COMBAT VEHICLE PARTS 275 275 275

PROBLEM - PRESSURE CASTING UTILIZING INTERNAL REINFORCEMENTS HAVE NOT BEEN DEVELOPED.

SOLUTION - PRODUCTION TECHNIQUES WILL BE DEVELOPED TO PRODUCE CASTINGS OF NEAR NET SHAPE WITH REINFORCEMENTS.



**TEST & EVALUATION COMMAND**

CATEGORY

TESTING

Testing ----- 221

US ARMY TEST AND EVALUATION COMMAND

(TECOM)

TECOM, with headquarters at Aberdeen Proving Ground, MD, is the primary developmental testing agency for the US Army. TECOM plans, conducts, and reports on development tests performed during the life cycle of Army materiel, and evaluates foreign materiel for possible US acquisition. Additional testing is performed as a service to the commodity commands upon their request. The testing organization consists of the aircraft development test activity, three environmental testing activities, five proving grounds (one of which serves as the third testing activity), and a national missile range. Facilities are located in the continental United States, the Panama Canal Zone and Alaska.

Individual investigations into production test procedures and evaluation techniques are accomplished through TECOM's MMT program. In view of TECOM's mission and the intended results of the MMT efforts (to improve test procedures), the majority of the work is accomplished in-house.

TECOM's MMT efforts are grouped under two general headings: documentation and resource conservation. Individual efforts are funded from these "parent programs." Current funding constrains TECOM to an annual program that supports approximately one-half of their planned efforts.

TECOM

C O M M A N D F U N D I N G S U M M A R Y  
(THOUSANDS)

CATEGORY -----	FY80 ----	FY81 ----	FY82 ----	FY83 ----	FY84 ----
TESTING	822 ----	1000 ----	1100 ----	1200 ----	1299 ----
TOTAL	822	1000	1100	1200	1299

MMT FIVE YEAR PLAN  
RCS DRCMT 126

\*\*\*\*\*  
\* C A T E G O R Y \*  
\*-----\*  
\*TESTING\*  
\*\*\*\*\*

FUNDING (\$000)

PRDUR 80 81 82 83 84

COMPONENT -- DOCUMENTATION

(5071) TITLE - TECOM PRODUCTION TEST METHODOLOGY ENGINEERING MEASURES 1533 308 375 413 450 487

PROBLEM - STANDARD TEST PROCEDURES ARE REQUIRED TO INSURE THAT TEST ACTIVITIES COLLECT DATA AND CONDUCT TESTS IN A UNIFORM MANNER TO SUPPORT THE DT EVALUATION PROCESS. ACCEPTANCE TEST PROCEDURES ARE REQUIRED TO VERIFY PRN HARDWARE SPECIFICATION COMPLIANCE.

SOLUTION - MAINTAIN TEST OPERATIONS PROCEDURES AND ACCEPTANCE TEST PROCEDURES TO TEST SYSTEMS FOR SPECIFICATION COMPLIANCE.

COMPONENT -- RESOURCE CONSERVATION

(5071) TITLE - TECOM PRODUCTION TEST METHODOLOGY ENGINEERING MEAS 1840 370 450 495 540 585

PROBLEM - ARTILLERY, VEHICLE AND ELECTRONIC CONVENTIONAL TEST CAPABILITIES NEED TO BE UPGRADED TO PROVIDE MORE TIMELY ACCURATE TEST DATA FOR THE TEST AND EVALUATION PROCESS.

SOLUTION - DEVELOP A PROGRAM TO UPGRADE CONVENTIONAL TEST CAPABILITIES AT THE TEST ACTIVITIES.

(5071) TITLE - TECOM PRODUCTION TEST METHODOLOGY ENGINEERING MEASURES 716 144 175 192 210 227

PROBLEM - FIELD TESTING COMPLEX WEAPON SYSTEMS IS COST PROHIBITIVE. SIM TECHNIQUES MUST BE DEVELOPED TO REDUCE THE COST AND MANPOWER REQUIRED TO PERFORM GOVT TESTS ROUTINE. PDN TEST PROCESSES MUST BE AUTOMATED BECAUSE OF PERSONNEL REDUCTIONS AT TEST ACTIVITIES

SOLUTION - DEVELOP SIMULATION TECHNIQUES TO TEST COMPLEX WEAPON SYSTEMS AND AUTOMATE PRODUCTION TEST PROCESSES.

## APPENDICES

## INDUSTRY GUIDE

This section of the MMT Program Plan explains the Army programming cycle for the MMT Program. The objective of the MMT Program is to develop new manufacturing methods and processes that will reduce the cost of producing weapon systems. The program is made up of 200 projects annually that concentrate on improving and/or developing manufacturing methods, techniques and processes.

The scope of the MMT Program covers all three of the military services. Within the Army, the Office of Manufacturing Technology (OMT) has been established to provide overall program responsibility. Functional responsibility is at the commodity oriented, Major Subcommands. The Subcommands plan, formulate, budget, and execute individual projects. The Industrial Base Engineering Activity (IBEA) assists OMT on the technical aspects of the manufacturing technology program. The chart on the next page depicts this supporting framework.

Throughout the Program Plan reference is made to various appropriations. These appropriations are identified in the Army Management Structure (AR 37-100-FY) and are established by the US Congress as a standard accounting system. Most MMT efforts are funded through the Procurement Appropriations which include (1) Aircraft, (2) Missile, (3) Weapons and Tracked Combat Vehicles, (4) Ammunition, and (5) Other. A few projects receive funds from the Operations Maintenance, Army (OMA) appropriation. Each of these appropriations have a unique code identified for funding MMT efforts. These codes along with the projected funds are contained in the Summary section on page 3 of this document.

Identification of manufacturing problems is the first step in developing an MMT Program. Problem areas are conceptualized and compiled into a planning document (i.e. POM Support Document). As the program cycle proceeds the concepts are refined, project proposals are developed, and the planning document is updated (forming the Program Plan). A diagram depicting this programming cycle is shown on page A-3. To fully understand the entire programming cycle one must realize that DOD budgets funds based upon a Fiscal Year. The FY starts on 1 October and ends the last day of the following September. For example, on 1 October 1980, the Army will begin the first quarter of FY81.



Calendar Year Activities  
MMT Planning/Budgeting/Review Cycle

YEARLY ACTIVITIES

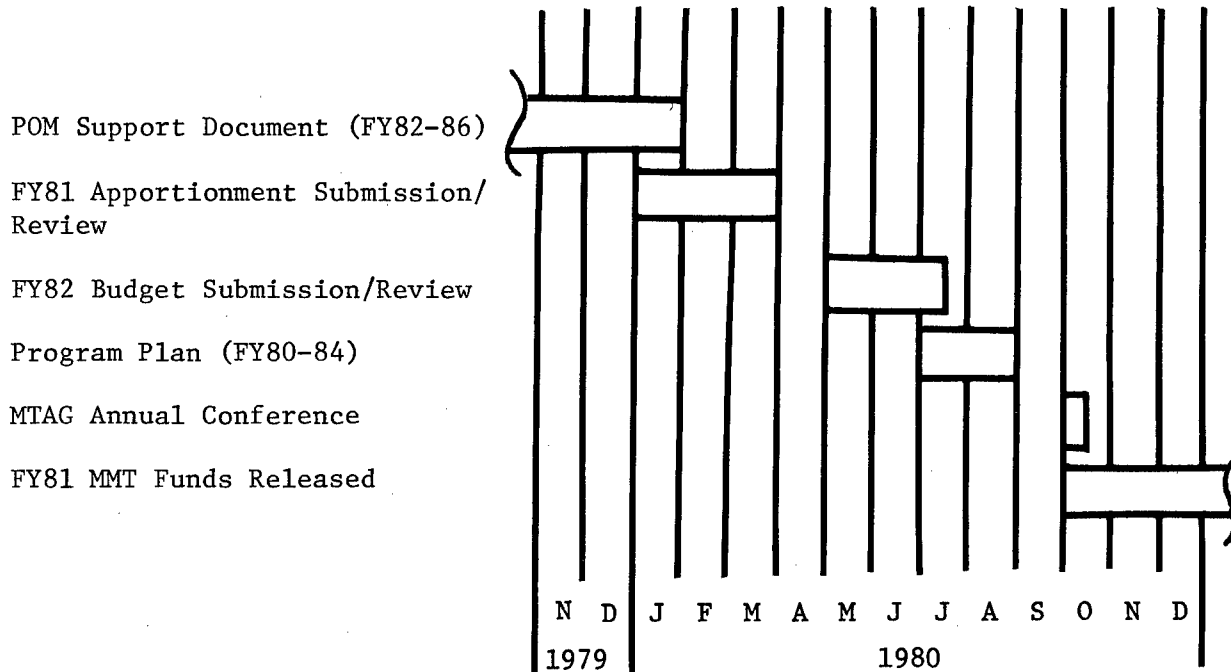

This chart depicts the various activities and stages that MMT projects go through. Concepts are first identified in the five year plan according to the projected year funding is expected. Each year these concepts are reevaluated and move forward until they reach the budget phase. At that time the concept is further refined and a project prepared. Industry has the opportunity to participate during the annual MTAG conference. At this gathering the current program, the latest budget project and the Program Plan are discussed.

The programming cycle shown on the previous page starts with the POM Support Document. This document is a long range planning document that consolidates individual submissions from the Major Subcommands and makes up what is known as the planned program. Because long range Army budget guidance provides "ceilings," potential projects must be prioritized which results in some being excluded or slipped. Inclusion in the Plan does not guarantee that the project will be funded. The level of funding is dependent upon what Congress will appropriate each year.

As projects in the POM Support Document approach the start of the funding cycle specific objectives and work scopes are developed. These projects are documented in what is known as a P-16. A P-16 is simply the format that is utilized to document data elements such as estimated cost, economics, and description of work. (The P-16 format is described in AR 700-90).

The budget submission represents the first P-16 submitted for inclusion in the program. This submission is followed about nine months later by the more definite apportionment submission. Projects are then funded when the new fiscal year begins. Although this is the normal planning cycle, a project can enter the planning cycle at any point in time. Such a project would be known as a late start submission and funding is usually at the expense of another project.

Criteria for actually funding individual projects include technical, operational, and economical feasibility. The potential for technical success, the means by which the results will be implemented, the potential payback or return on investment and the interrelationships that exist between factors are all evaluated.

For a more comprehensive understanding of the MMT program, the following list of documents are provided for reference:

DOD Instruction 4200.15, Manufacturing Technology Program

AR 700-90, The Army Industrial Preparedness Program

AR 37-100, The Army Management Structure

AR 11-28, Economic Analysis and Program Evaluation for Resources Management

ARMY MMT PROGRAM REPRESENTATIVES

HQ, DARCOM

US Army Materiel Development and Readiness Command  
ATTN: DRCMT  
5001 Eisenhower Avenue  
Alexandria, VA 22333

C: 202 274-8284/8298  
AV: 284-8284/8298

AVRADCOM

US Army Aviation R&D Command  
ATTN: DRDAV-EXT, Mr. Robert Vollmer  
12th & Spruce Streets  
St. Louis, MO 63166

C: 314 263-1625  
AV: 693-1625

CERCOM

US Army Communications & Electronics Materiel Readiness Command  
ATTN: DRSEL-LE-R, Mr. Martin Ides  
Fort Monmouth, NJ 07703

C: 201 532-4950  
AV: 992-4950

CORADCOM

US Army Communications R&D Command  
ATTN: DRDCO-PPA-TP, Mr. Al Feddeler/Sam Esposito/Burton Resnic  
Building 2700  
Fort Monmouth, NJ 07703

C: 201 535-2418/4262/4026  
AV: 995-2418/4262/4026

ERADCOM

US Army Electronics R&D Command  
ATTN: DELET-R, Mr. Joseph Key  
Fort Monmouth, NJ 07703

C: 201 544-4258  
AV: 995-4258

MICOM

US Army Missile Command  
ATTN: DRSMI-ET, Mr. Ray Farison  
Redstone Arsenal, AL 35809

C: 205 876-1835  
AV: 746-1835

TARADCOM

US Army Tank-Automotive R&D Command  
ATTN: DRDTA-KP, DRDTA-RCK, Dr. Jim Chevalier  
Warren, MI 48090

C: 313 573-2065/1814/2467  
AV: 273-2065/1814/2467

TARCOM

US Army Tank-Automotive Materiel Readiness Command  
ATTN: DRSTA-EB, Ms. Vivian Buarkhalter  
Warren, MI 48090

C: 313 573-2074/2545  
AV: 273-2074/2545

ARRCOM

US Army Armament Materiel Readiness Command  
ATTN: DR SAR-IRB, Mr. August Zahatko  
Rock Island Arsenal  
Rock Island, IL 61299

C: 309 794-4485/3730  
AV: 793-4485/3730

ARRADCOM

US Army Armament R&D Command  
ATTN: DRDAR-PML, Mr. Donald J. Fischer  
Dover, NJ 07801

C: 201 328-6714/6715  
AV: 880-6714/6715

TSARCOM

US Army Troop Support and Aviation Materiel Readiness Command  
ATTN: DRSTS-PLP(2), Mr. Don G. Doll  
4300 Goodfellow Blvd.  
St. Louis, MO 63120

C: 314 263-3040  
AV: 693-3040

MERADCOM

US Army Mobility Equipment R&D Command  
ATTN: DRDME-UPE, Mr. R. Goehner  
Fort Belvoir, VA 22060

C: 703 664-5530  
AV: 354-5530

NARADCOM

US Army Natick R&D Command  
ATTN: DRDNA-EZM, Mr. Frank Civilikas  
Natick, MA 01760

C: 617 653-1000, x2793/4  
AV: 955-2349/2351

TECOM

US Army Test & Evaluation Command  
ATTN: DRSTE-AD-M, Mr. Grover Shelton  
Aberdeen Proving Ground, MD 21005

C: 301 278-3677  
AV: 283-3677

AMMRC

US Army Materials & Mechanics Research Center  
ATTN: DRXMR-PMT, Mr. Raymond Farrow  
Watertown, MA 02172

C: 617 923-3523  
AV: 955-3523

HDL

Harry Diamond Laboratories  
ATTN: DELHD-PP, Mr. Julius Hoke  
2800 Powder Mill Road  
Adelphi, MD 20783

C: 202 394-1551  
AV: 290-1551

Rock Island Arsenal

ATTN: SARRI-ENM, Mr. Joseph DiBenedetto  
Rock Island, IL 61299

C: 309 794-4627/4584  
AV: 793-4627/4584

Watervliet Arsenal

ATTN: SARWV-PPI, Mr. L. A. Jette  
Watervliet, NY 12189

C: 518 266-5318  
AV: 974-5318

US Army Munitions Production Base Modernization Agency

ATTN: SARPM-PBM, Mr. Joseph Taglairino  
Dover, NJ 07801

C: 201 328-6708  
AV: 880-6708

AMRDL

US Army Applied Technology Laboratory  
USARTL (AVRADCOM)  
ATTN: DAVDL-ATL-TAS, Mr. L. Thomas Mazza  
Fort Eustis, VA 23604

C: 804 878-5732  
AV: 927-5732

DESCOM

US Army Depot System Command  
ATTN: DRSDS-PE, Mr. Jim Shindle  
Chambersburg, PA 17201

C: 717 263-6321  
AV: 242-6321

IBEA

US Army Industrial Base Engineering Activity  
ATTN: DRXIB-MT, Mr. James Carstens  
Rock Island, IL 61299

C: 309 794-5113  
AV: 793-5113

DCSRDA

ATTN: DAMA-CSM, Mr. Rod Vawter  
Room 3C400, The Pentagon  
Washington, DC 20310

C: 202 695-0506/07/08  
AV: 225-0506/07/08

DCSRDA (PA 1497, Aircraft)

ATTN: DAMA-WSA, LTC Jay B. Bisbey  
Room 3B454, The Pentagon  
Washington, DC 20310

C: 202 695-1362  
AV: 225-1362

DCSRDA (PA 2597, Missiles)

ATTN: DAMA-WSM-A, Mr. John Doyle  
Room 3B485, The Pentagon  
Washington, DC 20310

C: 202 695-8740  
AV: 224-8740

DCSRDA (PA 3297, Weapons; PA 3197, Tracked Combat Vehicles)

ATTN: DAMA-WSW, MAJ Gordon Winder  
Room 3D455, The Pentagon  
Washington, DC 20310

C: 202 697-0106  
AV: 227-0106

DCSRDA (PA 5297, Communications/Electronics)

ATTN: DAMA-CSC-BU, COL Higgins  
Room 3D440, The Pentagon  
Washington, DC 20310

C: 202 695-1881  
AV: 225-1881

DCSRDA (Other Procurement Activities:

PA 5197, Tactical and Support Vehicles)

ATTN: DAMA-CSS-P, LTC L. R. Hawkins  
Room 3D416, The Pentagon  
Washington, DC 20310

C: 202 694-8720  
AV: 224-8720

DCSRDA (Other Procurement Activities:

PA 5397, Other Support)

ATTN: DAMA-CSS-P, LTC P. K. Linscott  
Room 3D418, The Pentagon  
Washington, DC 20310

C: 202 694-8720  
AV: 224-8720

DCSRDA (PA 4950, Ammunition)

ATTN: DAMA-CSM-DA, COL Jack King  
Room 3C444, The Pentagon  
Washington, DC 20310

C: 202 694-4330  
AV: 224-4330

DCSRDA (PA 4950, Ammunition)

ATTN: DAMA-CSM-P, Mr. John Mytryshyn  
Room 3C444, The Pentagon  
Washington, DC 20310

C: 202 694-4330  
AV: 224-4330

INDUSTRIAL BASE ENGINEERING ACTIVITY (IBEA)  
POINTS OF CONTACT  
FOR  
MANUFACTURING METHODS AND TECHNOLOGY

	<u>Telephone Number*</u>
Mr. James Gallagher, Director -----	(309) 794-5010
Mr. James Carstens, Chief, Manufacturing Technology Division -----	(309) 794-5113
Mr. Al Adlfinger -----	(309) 794-6172
Mr. Ferrel Anderson -----	(309) 794-5235
Mr. Ken Bezaury -----	(309) 794-6586
Mr. Delmar Brim -----	(309) 794-6586
Ms. Linda Hancock -----	(309) 794-6172
Mr. Robert Hellem -----	(309) 794-6586
Mr. Wayne Hierseman -----	(309) 794-5235
Mr. Andrew Kource, Jr. -----	(309) 794-5235
Mr. Peter Martin -----	(309) 794-5235
Mr. Charles McBurney -----	(309) 794-6172
Mr. Steve McGlone -----	(309) 794-6172
Mr. Gordon Ney -----	(309) 794-6586
Mr. Alan Peltz -----	(309) 794-6586
Mr. John Petrone -----	(309) 794-6172
Mr. James Sullivan -----	(309) 794-6172
Mr. Hal Weidner -----	(309) 794-6172
Mr. James Weintraut -----	(309) 794-5235
Mr. Steve Yedinak -----	(309) 794-6172
Mr. Ed Zajakala -----	(309) 794-6586

\*AUTOVON: 793-XXXX

DRXIB-MT  
DISTRIBUTION:

Defense Technical Information Center:

Document Processing Division, Attn: DDC-DDA-2, Mr. Richard Matthews (12 cys)

Department of Defense:

DIRSO, Attn: Mr. Charles Downer (3 cys)  
OUSD (R&D), The Pentagon, Attn: Dr. Lloyd L. Lehn (10 cys)

Department of the Army:

HQDA, OASARDA, The Pentagon, Attn: Mr. Eugene S. Davidson  
HQDA, ODCSRDA, The Pentagon, Attn: DAMA-PPM-P, Mr. Rod Vawter  
DCSRDA, Attn: DAMA-WSA, LTC Jay B. Bisbey  
DCSRDA, Attn: DAMA-WSM-A, Mr. John Doyle  
DCSRDA, Attn: DAMA-WSW, MAJ Gordon Winder  
DCSRDA, Attn: DAMA-CSC-BU, COL Higgins  
DCSRDA, Attn: DAMA-CSS-P, LTC L. R. Hawkins, LTC P. K. Linscott  
DCSRDA, Attn: DAMA-CSM-P, Mr. John Mytryshyn  
DCSRDA, Attn: DAMA-CSM-DA, COL Jack King

HQ DARCOM:

Cdr, DARCOM, Attn: DRCCG  
Cdr, DARCOM, Attn: DRCMDM  
Cdr, DARCOM, Attn: DRCDMR  
Cdr, DARCOM, Attn: DRCPP  
Cdr, DARCOM, Attn: DRCPP-I (3 cys)  
Cdr, DARCOM, Attn: DRCDE  
Cdr, DARCOM, Attn: DRCMT (20 cys)  
Technical Library, Attn: DRXAM-L

AVRADCOM:

PM, Advanced Attack Helicopter, Attn: DRCPM-AAH  
PM, Blackhawk, Attn: DRCPM-BH  
Cdr, Attn: DRDAV  
Cdr, Attn: DRDAV-EXT, Mr. Robert Vollmer  
Technical Library, St. Louis, MO  
Cdr, AMRDL, Attn: SAVDL-EU-TAS, Mr. L. Thomas Mazza

ARRADCOM:

PM, Cannon Artillery Weapons Systems, Attn: DRCPM-CAWS  
PM, Division Air Defense (DIVAD) Gun, Attn: DRCPM-ADG  
PM, Nuclear Munitions, Attn: DRCPM-NUG  
PM, Selected Ammunition, Attn: DRCPM-SA  
Cdr, Attn: DRDAR  
Cdr, Attn: DRDAR-PML, Mr. Donald J. Fischer (7 cys)  
Cdr, Benet Wpns Lab, Attn: DRDAR-LCB-S, Mr. Slawsky  
Chemical Systems Lab, Technical Library, Attn: DRDAR-CLY-T

DRXIB-MT  
DISTRIBUTION (Cont'd):

Aberdeen Proving Ground:

PM, Chemical Demilitarization & Installation Restoration, Attn: DRCPM-DR  
PM, Smoke/Obscurants (SMOKE), Attn: DRCPM-SMK  
Cdr, Attn: STEAP-MT-M, Mr. J. L. Sanders

ARRCOM:

PM, M110E2 Weapon System, Attn: DRSAR-HA  
Cdr, Attn: DRSAR-CG  
Cdr, Attn: DRSAR-IRB, Mr. August Zahatko (4 cys)  
Cdr, Attn: DRSAR-IRW, Mr. Arne Madsen  
Cdr, Attn: DRSAR-LEP, Mr. R. F. Tumasonis  
Technical Library, Attn: DRSAR-LEP-L

AMMRC:

Dir, Attn: DRXMR-PMT, Mr. Raymond Farrow  
Dir, Attn: DRXMR-EO, Dr. Morton Kliman  
Dir, Attn: DRXMR, DRXMR-M (3 cys ea)  
Technical Library, Watertown, MA

CERCOM:

PM, Signal Intelligence/Electronic Warfare (SIGINT/EW), Attn: DRCPM-SIEW  
Cdr, Attn: DRSEL  
Cdr, Attn: DRSEL-LE-R, Mr. Martin Ides

CORADCOM:

PM, Army Tactical Communications Systems (ATACS), Attn: DRCPM-ATC  
PM, Automatic Test Support Systems, Attn: DRCPM-ATSS  
Cdr, Attn: DRDCO  
Cdr, Attn: DRDCO-PPA-TP, Messrs. Feddeler, Esposito, Resnic (1 cy ea)  
RD&E Technical Documents Ctr, Ft. Monmouth, NJ

DESCOM:

Cdr, Attn: DRSDS  
Cdr, Attn: DRSDS-PE, Mr. Jim Shindle

ERADCOM:

PM, FIREFINDER, Attn: DRCPM-FF  
PM, Remotely Monitored Battlefield Sensor Systems (REMBASS), Attn: DRCPM-RBS  
PM, Stand-off Target Acquisition System, Attn: DRCPM-STA  
Cdr, Attn: DRDEL  
Cdr, Attn: DELET-R, Messrs Key, Reich (1 cy ea)  
Cdr, Attn: DRDEL-ED, Mr. Harold Garson

MERADCOM:

PM, Mobile Electric Power, Attn: DRCPM-MEP (Springfield, VA)  
Cdr, Attn: DRDME  
Cdr, Attn: DRDME-UPE, Mr. R. Goehner  
Technical Library, Ft. Belvoir, VA

DRXIB-MT  
DISTRIBUTION (Cont'd):

MICOM:

PM, General Support Rocket System, Attn: DRCPM-RS  
PM, Ground Laser Designators, Attn: DRCPM-LD  
PM, HAWK, Attn: DRCPM-HA  
PM, Heliborne Laser Fire and Forget (HELLFIRE) Missile System,  
Attn: DRCPM-HE  
PM, High Energy Laser System, Attn: DRCPM-HEL  
PM, PATRIOT, Attn: DRCPM-MD  
PM, 2.75 Rocket System, Attn: DRCPM-RK  
PM, STINGER, Attn: DRCPM-MP  
PM, TOW-DRAGON, Attn: DRCPM-DT  
PM, US ROLAND, Attn: DRCPM-ROL  
PM, VIPER, Attn: DRCPM-VI  
Cdr, Attn: DRSMI  
Cdr, Attn: DRDMI-ET, Mr. Ray Farison  
Cdr, Attn: DRCMI-EAT, Mr. Austin  
Magazine Room, Attn: RSIC

NARADCOM:

Cdr, Attn: DRDNA  
Cdr, Attn: DRDNA-EAM, Mr. Frank Civilikas  
Technical Library, Attn: DRXTM-TRL

TARCOM:

PM, Heavy Equipment Transporter (HET), Attn: DRCPM-HT  
Cdr, Attn: DRSTA  
Cdr, Attn: DRSTA-EB, Ms Vivian Buarkhalter

TECOM:

Cdr, Attn: DRSTE  
Cdr, Attn: DRSTE-AD-M, Mr. Glover Shelton  
Technical Library, Dugway, UT  
Technical Library, White Sands Missile Range, Attn: STEWS-PT-AL  
Technical Library, Yuma, AZ

TSARCOM:

PM, COBRA, Attn: DRCPM-CO  
Cdr, Attn: DRSTS  
Cdr, Attn: DRSTS-PLEP(2), Mr. Don G. Doll

TARADCOM:

PM, Armored Combat Vehicle Technology (ACVT), Attn: DRCPM-CVT  
PM, Fighting Vehicle Armament, Attn: DRCPM-FVA  
PM, Fighting Vehicle Systems, Attn: DRCPM-FVS  
PM, Improved TOW Vehicle, Attn: DRCPM-ITV  
PM, XM-1 Tank System, Attn: DRCPM-GCM  
Cdr, Attn: DRDTA  
Cdr, Attn: DRDTA-KP, DRDTA-RCK, Mr. J. Chevalier  
Technical Library, Warren, MI

DRXIB-MT

DISTRIBUTION (Cont'd):

Arsenals:

Cdr, Pine Bluff Arsenal (PBA), Attn: SARPB  
Cdr, Rocky Mountain Arsenal (RMA), Attn: SARRM-IS  
Cdr, Rock Island Arsenal (RIA), Attn: SARRI-CO  
Cdr, RIA, Attn: SARRI-ENM, Mr. Joseph DiBenedetto  
Cdr, Watervliet Arsenal (WVA), Attn: SARWV  
Cdr, WVA, Attn: SARWV-PPI, Mr. L. A. Jette  
Cdr, Benet Wpns Tech Library, Watervliet, NY

Munitions Production Base Modernization Agency:

Cdr, MPBMA, Attn: SARPM-PBM-PB, Mr. Joseph Taglairino (6 cys)

Army Ammo Plants:

Cdr, Crane AAA, Attn: SARCN  
Cdr, Hawthorne AAP, Attn: SARHW  
Cdr, Holston AAP, Attn: SARHO  
Cdr, Indiana AAP, Attn: SARIN  
Cdr, Iowa AAP, Attn: SARIO  
Cdr, Kansas AAP, Attn: SARKA  
Cdr, Lake City AAP, Attn: SARLC  
Cdr, Lone Star AAP, Attn: SARLS  
Cdr, Longhorn AAP, Attn: SARLO  
Cdr, Louisiana AAP, Attn: SARLA  
Cdr, McAlester AAP, Attn: SARMC-FD  
Cdr, Milan AAP, Attn: SARMI  
Cdr, Mississippi AAP, Attn: SARMS  
Cdr, Radford AAP, Attn: SARRA  
Cdr, Riverbank AAP, Attn: SARRB  
Cdr, Scranton AAP, Attn: SARSC

Depots:

Cdr, Anniston Army Depot, Attn: SDSAN-MD  
Cdr, Corpus Christi Army Depot, Attn: SDSCC-MPI  
Cdr, Letterkenny Army Depot, Attn: SDSLE-MM  
Cdr, New Cumberland Army Depot, Attn: SDSNC-ME  
Cdr, Red River Army Depot, Attn: SDSRR-MO  
Cdr, Sacramento Army Depot, Attn: SDSSA-MPE  
Cdr, Seneca Army Depot, Attn: SDSSE-OP  
Cdr, Sharpe Army Depot, Attn: SDSSH-R  
Cdr, Sierra Army Depot, Attn: SDSI-EM  
Cdr, Tobyhanna Army Depot, Attn: SDSTO-M  
Technical Library, Tobyhanna, PA  
Cdr, Tooele Army Depot, Attn: SDSTE-MAN

DRXIB-MT

DISTRIBUTION (Cont'd):

Army Organizations:

Cdr, Army Logistics Management Ctr, (ALMC), Attn: DRXMD  
Cdr, Army Research Office (ARO), Attn: DRXRO-AO  
Cdr, Army Ballistic Research Labs (BRL), Attn: DRDAR-BL  
Cdr, HDL, Attn: DELHD-PP, Mr. Julius Hoke  
Cdr, Ballistic Research Lab, Attn: DRXBR-TSB-S  
Cdr, Foreign Science and Technology Ctr (FSTC), Attn: DRXST-MT1,  
Mr. James Wamsley  
Dir, Installations and Services Activity (I&SA), Attn: DRCIS  
Dir, Army Management Engineering Training Acty (AMETA), Attn: DRXOM-SE,  
Dr. Shallman (3 cys)  
Cdr, Night Vision Labs (VNL), Attn: DRSEL-NV-PA/IO  
US Army Research Office, Research Triangle Park, NC  
Scientific & Technical Information Div., Attn: DRXMC-ITG-AL  
Plastics Technical Evaluation Ctr., Attn: Mr. Harry Peibly

Navy Organizations:

Cdr, NAVMAT, Attn: CPT F. B. Hollick, Code 064  
Cdr, NAVSEA, Attn: T. E. Draschil, Code C-0354  
Cdr, NAVAIR, Attn: D. S. Henderson, Code ESA-824  
Cdr, NAVLEX, Attn: C. A. Rigdon, Code ELEX-504512  
Cdr, Naval Surface Wpns Ctr/White Oak Lab, Attn: Code E345, Mr. Chas McFann  
Cdr, Naval Surface Wpns Ctr/Dahlgren Lab, Attn: Code CM-51  
Cdr, Naval Weapons Ctr, Attn: D. M. Bullat, Code 36804  
Dir, NMCIRD, Bldg 75-2, Naval Base

Air Force:

Cdr, HQ, USAF/RDXI, The Pentagon, Attn: MAJ D. Mackintosh  
Cdr, AFSC/DLF, Andrew AFB  
Cdr, AFSC/PPD, Andrew AFB  
Cdr, AFML/LT, WPAFB  
Cdr, AFML/LTE, /LTM, /LTN, WPAFB (1 cy ea)  
Cdr, AFML/MX, WPAFB  
Cdr, San Antonio Air Logistics Ctr, Kelly AFB, Attn: E. Boisvert, MMEWA

Professional Societies:

Electronic Industrial Association, Attn: Mr. Jean Caffiaux, 2001 I St.,  
N.W., Washington, DC 20006 (40 cys)  
Numerical Control Society, Attn: Mr. Ronald C. Hunt, Exec. Dir., 519-520  
Zenith Dr., Glenview, IL 60025 (3 cys)  
Aerospace Industries Association, Attn: Mr. Robert Worthen, Col, US Army  
(Ret), 740 15th Street, N.W. Suite 819, Washington, DC 20015 (5 cys)  
American Defense Preparedness Association, Attn: Mr. Rudolph Rose, Col,  
US Army (Ret), 740 15th St., N.W., Suite 819, Washington, DC 20015 (5 cys)

DRXIB-MT  
DISTRIBUTION (Cont'd):

Professional Societies (Cont'd):

Society of Manufacturing Engineers, Attn: Mr. Bernard Sallot, One SME Drive, P.O. Box 930, Dearborn, MI 48128 (5 cys)  
American Institute of Industrial Engineers, Attn: Mr. Mikell Groover, Packard Lab #19, Lehigh University, Bethlehem, PA 18015 (1 cy)  
Forging Industry Association, Attn: Mr. C. G. Scofield, Room 1121, 55 Public Square, Cleveland, OH 44113 (35 cys)  
American Society for Testing and Materials, Attn: Mr. Samuel F. Etris, Special Assistant, 1916 Race Street, Philadelphia, PA 19103 (5 cys)  
Cast Metal Federation, Attn: Mr. William E. Gephardt, Chairman, Govt. Supply Committee, 4870 Packard Road, Niagara Falls, NY 14304 (1 cy)  
Metcut Research Associates, Inc., Attn: Mr. John F. Kahles, 3980 Rosslyn Drive, Cincinnati, OH 45209 (1 cy)