

**REPORT DOCUMENTATION PAGE**Form Approved  
OMB No. 074-0188

Public reporting burden for this collection of information is estimated to average 1 hour per response, including the time for reviewing instructions, searching existing data sources, gathering and maintaining the data needed, and completing and reviewing this collection of information. Send comments regarding this burden estimate or any other aspect of this collection of information, including suggestions for reducing this burden to Washington Headquarters Services, Directorate for Information Operations and Reports, 1215 Jefferson Davis Highway, Suite 1204, Arlington, VA 22202-4302, and to the Office of Management and Budget, Paperwork Reduction Project (0704-0188), Washington, DC 20503

<b>1. AGENCY USE ONLY (Leave blank)</b>		<b>2. REPORT DATE</b> May 1997	<b>3. REPORT TYPE AND DATES COVERED</b>	
<b>4. TITLE AND SUBTITLE</b> Actively Controlled Afterburner for Compact Waste Incineration			<b>5. FUNDING NUMBERS</b> N/A	
<b>6. AUTHOR(S)</b> T.P. Parr, K.J. Wilson R.A. Smith, K.C. Schadow, D.W. Hansell, J.A. Cole				
<b>7. PERFORMING ORGANIZATION NAME(S) AND ADDRESS(ES)</b>  Research and Technology Division, Code 474320D Naval Air Warfare Center Weapons Division China Lake, CA 93555-6001			<b>8. PERFORMING ORGANIZATION REPORT NUMBER</b> N/A  Energy and Environmental Research Corporation 18 Mason Street Irvine, CA 92617-2706	
<b>9. SPONSORING / MONITORING AGENCY NAME(S) AND ADDRESS(ES)</b> SERDP 901 North Stuart St. Suite 303 Arlington, VA 22203			<b>10. SPONSORING / MONITORING AGENCY REPORT NUMBER</b> N/A	
<b>11. SUPPLEMENTARY NOTES</b> Presented at the 16th International Conference on Incineration and Thermal Treatment Technologies, May 1997				
<b>12a. DISTRIBUTION / AVAILABILITY STATEMENT</b> Approved for public release: distribution is unlimited.			<b>12b. DISTRIBUTION CODE</b> A	
<b>13. ABSTRACT (Maximum 200 Words)</b> Active control of fluid dynamics has been used to enhance mixing in incinerator afterburner experiments and increase the DRE for a waste surrogate. Experiments were conducted in a 50 kW scale burner as well as 400 to 1200 kW burners which match the heat release rate of the proposed full scale afterburner for a compact shipboard methodology previously shown, in sub scale tests, to greatly increase DRE, reduce emissions, and allow much more compact incineration, has been proven to work at the full scale level. The open loop active control system is based on the concept of combustion in periodic axisymmetric vortices. Acoustic excitation was used to stabilize coherent vortices in the central air flow of a sump combustor like configuration. The fuel and waste are injected annularly at the dump. The pyrolysis surrogate is modulated indirectly by periodic entrainment created by roll-up of the main air vortex, as well as acoustic excitation of secondary air injection. The phase angle is controlled such that the combustibles are introduced into the air vortex at the right time during the vortex formation. This leads to good mixing, a controlled yet lifted partially premixed flame, high DRE and low pollutant emissions.				
<b>14. SUBJECT TERMS</b> DRE; afterburner; incineration; incinerator; SERDP; SERDP Collection			<b>15. NUMBER OF PAGES</b> 11	
			<b>16. PRICE CODE</b> N/A	
<b>17. SECURITY CLASSIFICATION OF REPORT</b> unclass.	<b>18. SECURITY CLASSIFICATION OF THIS PAGE</b> unclass.	<b>19. SECURITY CLASSIFICATION OF ABSTRACT</b> unclass.	<b>20. LIMITATION OF ABSTRACT</b> UL	

NSN 7540-01-280-5500

Standard Form 298 (Rev. 2-89)  
Prescribed by ANSI Std. Z39-18  
298-102

19990521 120

## ACTIVELY CONTROLLED AFTERBURNER FOR COMPACT WASTE INCINERATOR

T. P. Parr, K. J. Wilson, R. A. Smith, and K. C. Schadow  
Research and Technology Division, Code 474320D  
Naval Air Warfare Center Weapons Division, China Lake, CA 93555-6001  
tim.parr@mail.chinalake.navy.mil

and

D. W. Hansell, and J.A. Cole  
Energy and Environmental Research Corporation  
18 Mason St.  
Irvine, CA 92618-2706

### ABSTRACT

Active control of fluid dynamics has been used to enhance mixing in incinerator afterburner experiments and increase the DRE for a waste surrogate. Experiments were conducted in a 50 kW scale burner as well as 400 to 1200 kW burners which match the heat release rate of the proposed full scale afterburner for a compact shipboard incineration system. The active control methodology previously shown, in sub scale tests, to greatly increase DRE, reduce emissions, and allow much more compact incineration, has been proven to work at the full scale level.

The open loop active control system is based on the concept of combustion in periodic axisymmetric vortices. Acoustic excitation was used to stabilize coherent vortices in the central air flow of a dump combustor like configuration. The fuel and waste are injected annularly at the dump. The pyrolysis surrogate is modulated indirectly by periodic entrainment created by roll-up of the main air vortex, as well as acoustic excitation of secondary air injection. The phase angle is controlled such that the combustibles are introduced into the air vortex at the right time during the vortex formation. This leads to good mixing, a controlled yet lifted partially premixed flame, high DRE and low pollutant emissions.

We report optimization of this control concept at the 50 kW level and scale-up to the MW regime. The geometry of the introduction of the waste surrogate and secondary air flow into the

main air flow vortex shedding point was varied. Experiments were done with the waste surrogate annular injection sandwiched between the forced main and secondary air flows as well as with it outside the secondary air injection annulus. In addition, the angle of injection of the waste surrogate and secondary air into the main air shear layer was varied between 80 and 15 degrees. In all cases the performance of the system could be optimized at approximately the same level (as indicated by benzene DRE or CO and UHC emissions). This shows the versatility of the technique to handle geometric constraints.

Further study of the NO<sub>x</sub> reduction potential of this active control indicated that NO<sub>x</sub> reductions as high as 30x were possible for lean stoichiometries. As richer stoichiometries were approached the NO<sub>x</sub> reduction became much less. The strong vortex forcing of the active control technique creates a partially premixed flame that is held off the dump plane by the high strain rates in the vortex roll up region. A partially premixed lean flame will, of course, be colder than regions of a similar lean diffusion flame, thereby leading to lower NO<sub>x</sub> production.

The same design principles used in the 50 kW scale combustor were applied to a 1.2 MW free jet version (China Lake), as well as a 400 kW scale enclosed version (at EER Corp.). The active control was still effective at these power levels despite the much higher Reynolds number. In the free jet tests (1.2 MW)

activation of the controller changed a long yellow flame to a shorter all blue flame. In enclosed tests (400 kW at EER) the controller reduced the CO emissions by a factor of over 20 and UHC emissions by a factor of over 150. In both cases the flame was lifted off the dump plane as with the sub-scale combustors.

## INTRODUCTION

The interaction between turbulent mixing processes and combustion is important in many practical applications such as airbreathing propulsion systems, energy conversion power plants, hazardous waste incinerators and other chemical reactors and industrial processes. Studies of turbulent mixing during the last two decades established the role of organized coherent large-scale vortical structures in the mass and momentum transfer across the shear layer between two fluids in motion (1-3). It was further determined that by manipulating these structures it is possible to alter the mixing process. Active control methods were devised to enhance the spreading rate of the shear layer by mechanical or acoustic excitation of the initial shear layer, and thus accelerate the mixing between the two streams (4, 5).

The understanding of the mechanism governing turbulent mixing and their control was extended to turbulent combustion. New laser based diagnostic techniques (6) with high temporal and spatial resolution, which yield species-specific two and three dimensional maps of the combustion region, accelerated the process; the important role of controlling the large and small scale mixing on the combustion process was determined (7). Initial studies of combustion control focused on the problem of combustion instabilities. The numerous studies on the application of active control to suppress combustion instabilities were reviewed recently by Candel (8) and McManus et al. (9). Active control by shear layer excitation was applied to enhance energy release (10-13) and to mitigate the production of pollutants (14). Fluid dynamic control has also been applied to hazardous waste incineration (15, 16).

At the Naval Air Warfare Center (NAWC), China Lake, the work on active combustion control included open and closed loop control of small scale (~10kW) and large scale (~1MW) combustors to enhance their performance by increasing energy release, extending the lean flammability limit, and stabilizing the combustion (17). The focus of the investigations shifted recently to emphasize practical applications such as the investigation of techniques for the development of compact waste incinerators for use aboard Navy ships. The common underlying concept of the combustion processes discussed in the present paper is vortex combustion. In practical combustors, the combustion process occurs at different locations within the combustion chamber depending on the air/fuel mixture and the fluid dynamic and thermodynamic conditions. Even if the average conditions are proper, it is common that the local conditions are not right for efficient combustion. The vortex combustion technique ensures that the combustion is confined to regions (i.e., vortices) within the combustor where optimal local conditions can be maintained. The vortex provides intense mixing and long residence time necessary for a complete combustion process. It also ensures localized high temperature to maintain efficient combustion. The fuel injection system can be designed for optimal utilization of the fuel by placing the fuel at the regions which provide the best conditions for its combustion. The purpose of the present paper is to study the method of synchronized fuel injection into air vortices, and its use for gaseous and liquid waste incineration.

## EXPERIMENTAL

The waste surrogate chosen was benzene, which is third on the EPA list of thermally stable, difficult to destroy hazardous compounds, as reported by Lee et. al. (18). Gaseous benzene was introduced into the systems by bubbling flow through a bottle of liquid benzene in a temperature controlled water bath. The fuel was ethylene and the pyrolysis surrogate was a mixture of nitrogen,

ethylene, and benzene at 62%, 31%, and 7% by weight. In all the DRE measurements reported here, the benzene constituted about 10 to 17% of the combustible content.

The medium scale incinerator (Fig 1), a direct scale up of the 4.5 kW laboratory unit, was gaseous fueled and generated 47-70 kW of heat release. The inlet diameter was 38.4 mm and the dump 178 mm. The velocity of the inlet jet

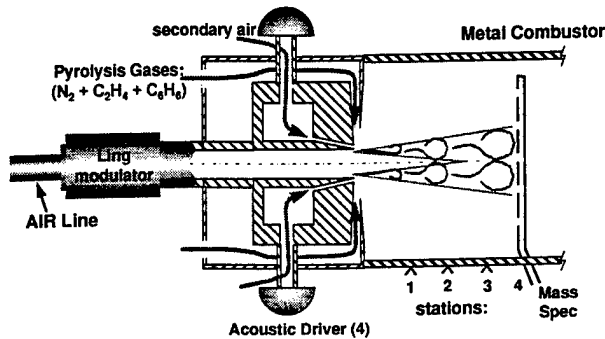

Fig. 1 Schematic diagram of the 50 kW actively controlled dump combustor incinerator afterburner concept. The probe fed a mass spectrometer for benzene DRE measurements as well as a continuous emissions monitor for CO, NO, NO<sub>2</sub>, and unburned hydrocarbons (UHC).

was 10.3 to 15.3 m/s for a Reynolds number of 26,000 to 39,000 based on the jet diameter. The measured preferred mode of the jet at 15 m/s was 190 Hz. The inlet flow was forced using a high speed acoustic valve (Ling Electronics™), and despite the order of magnitude increase in flow rate over the laboratory combustor, and nearly an order of magnitude increase in Reynolds number, it was easy to generate coherent vortices using less than 5 Watts, as shown by Mie scattering flow visualization in Fig. 2. The acoustical output power of the Ling™ valve increases sharply with increasing flow rate, even at constant electrical power input, so much larger incinerators could be controlled with similarly modestly powered controllers. Indeed the free jet tests on the MW scale combustor proved this to be true.

In the baseline afterburner configuration, shown in Fig. 1, ethylene, benzene, and nitrogen, used to simulate the output of a

primary pyrolysis chamber such as a kiln or plasma unit, were introduced circumferentially via an "entrainment" plate to enter the main air shear layer at the incipient vortex roll-up point.

This region is not directly forced, but PIV results reported previously (19) showed the entrainment is periodic due to the periodic roll-up of the central air vortices. Secondary air was then introduced through 38 holes of 2.3 mm diameter fed from an acoustically forced plenum. The plenum is forced with four 75 Watt acoustic compression drivers (they aren't driven beyond 35 Watts, however). This extra forced flow helps indirectly modulate the waste surrogate. In a real system the waste surrogate would be hot and perhaps difficult to modulate directly.

One variation on this configuration, referred to here as version 5, was nearly identical to the baseline with the exception that the waste surrogate was introduced through the 38 holes and the secondary air entered from the "entrainment" region. In addition, the waste surrogate plenum was not acoustically forced but the secondary air entrainment region was (Fig. 3). In this configuration the waste surrogate is sandwiched between the main air shear layer and the secondary air flow.



Fig. 2 Planar Mie scattering image of the coherent vortex produced in the larger scale dump combustor incinerator via acoustic forcing; flow is left to right.

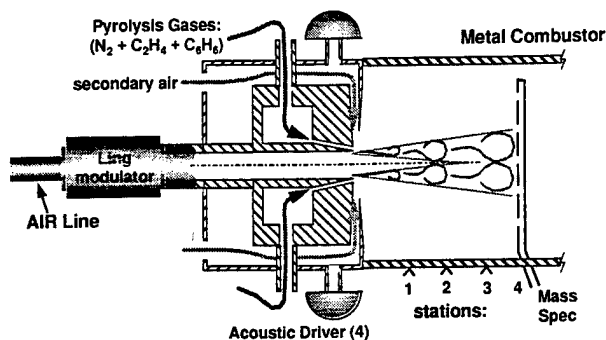

Fig. 3 Version 5 of the 50 kW afterburner. The waste surrogate flow is not directly forced but is sandwiched between the main air shear layer and the acoustically forced secondary entrainment air flow.

The remaining benzene in the exhaust was monitored with an on-line mass spectrometer tuned to  $m/e = 78$ . The probe was water cooled and several orifices averaged over the radial profile of the exit. The DRE (destruction and removal efficiency) was calculated from the benzene concentration remaining in the exhaust:  $DRE(\%) = 100 \times [1 - (\text{benzene out/benzene in})]$ . DREs are also often quoted as "nines" where 99.99% DRE corresponds to 4 nines and  $DRE(\text{nines}) = -\log_{10}(1 - DRE(\%)/100)$ . The sensitivity limit of the on line mass spectrometer corresponds to DREs of about 5 nines, depending on the amount of waste loading. This sensitivity was obtained by averaging over about 2 minutes per condition. It should be noted that a mass scan from 50 to 200 amu showed nothing but benzene when the DRE was low and nothing at all when the DRE was high, so even though subsequent tests were done monitoring only the mass of benzene the results are valid as the benzene is not just being converted to some other hazardous compound.

Another identical water cooled probe was directly attached to a continuous emission monitor which measured  $O_2$ ,  $CO_2$  (calculated),  $CO$ ,  $NO$ , and  $NO_2$ . Each probe could be placed at one of four locations within the 610 mm long combustor so that measurements could be made at various downstream  $x/D$  distances where  $x$  is the downstream mm and  $D$  is the dump diameter, 178 mm. Both probes were

mounted vertically to minimize sampling error caused by buoyancy, i.e. the multiple orifices of the probes averaged over a vertical radial profile across the duct.

## RESULTS and DISCUSSION

### Geometric Optimization

The performance of the combustor is dependent on mixing and this, in turn, depends critically on the geometry of the introduction of the waste surrogate and secondary air into the central air jet shear layer at the incipient formation location for vortex roll-up. Tests were undertaken to study the effects of geometry in this area on performance.

The first modification studied, version 5, reversed the normal radial location of the waste surrogate from previous afterburner combustor configurations: the waste surrogate was sandwiched, annularly, between the central air flow and the surrounding "entrainment", or secondary, air flow. The waste surrogate was not directly acoustically modulated but the secondary air flow was (see Fig. 3).

It was found that this geometric configuration was so efficient that it actually self-excited under many conditions. The periodic heat release from vortex combustion in the chamber apparently modulated the inlet flow in such a matter as to create coherent vortices in an acoustic feedback mechanism. The combustor mode under these conditions matched the preferred mode of the central air jet creating strong vortices as when the system is actively forced.

When started, it was possible to remove the forcing of both the central air jet and secondary air flow and the system would produce vortices by itself. Under these conditions the emissions were nearly as low as previously actively controlled versions. For example, the  $CO$  was 10 ppm and  $NO_x$  21 ppm (uncorrected for  $O_2\%$ ). This condition exhibited long term stability (as long as the input flow rate and heating value stayed constant). If the driving

frequency was kept near the preferred mode of the jet and combustor acoustic resonance mode then the vortex shedding could be locked using acoustic forcing of the secondary air flow alone. The emissions performance was the same under these conditions.

Unfortunately, when the system is self-exciting open loop active forcing cannot exercise much control and the performance is largely independent of the controller forcing parameters. Figure 4 shows the CO emissions as a function of position in the combustor downstream of the dump (normalized by the dump internal diameter D of 178 mm). Except for a single point (where the combustor may have become temporarily unstable) there is little difference in CO emissions for the conditions of controller off, central air forcing only, secondary air forcing only, both forcing, and both forcing at half power. The emissions axis in Fig. 4 is logarithmic and the CO appears to drop exponentially with increasing downstream distance [CO (ppm) = 45,000·exp(-3.5·x/D)].

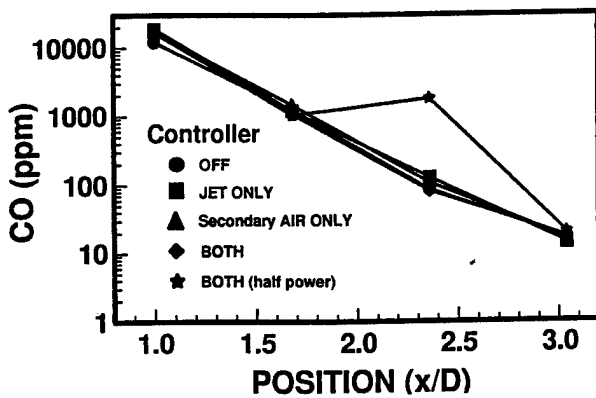

Fig. 4 CO ppm (uncorrected for O<sub>2</sub>%) for various states of the controller as a function of downstream distance normalized by the diameter of the dump (D = 178 mm).

Figure 5 shows that the DRE for benzene is likewise largely unaffected by the controller because of the self-excitation. Yet even with no active excitation at all, the DRE exceeded 4 nines at x/D of 2.3 (a little over a foot downstream from the dump).

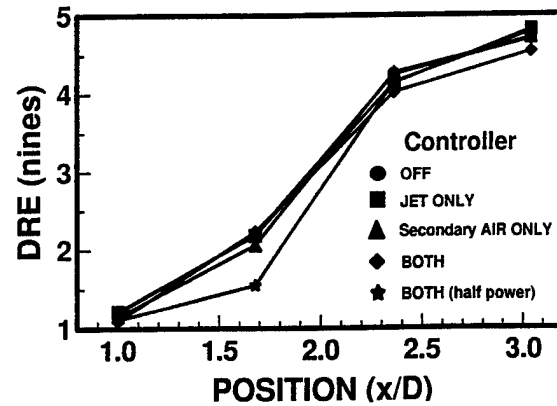

Fig. 5 DRE vs. downstream position for various states of the controller.

Figure 6 shows the NO<sub>x</sub> performance of this configuration. In most past tests the NO<sub>x</sub> increased with increasing downstream distance. This is consistent with continued thermal production of NO<sub>x</sub> with increased residence time at temperature. Figure 5 shows that in the version 5 configuration, however, the NO<sub>x</sub> appears to actually slightly decrease with increasing downstream distance. The actively controlled NO<sub>x</sub> levels were marginally below the uncontrolled levels and NO<sub>x</sub> concentrations as low as 4 ppm were seen.

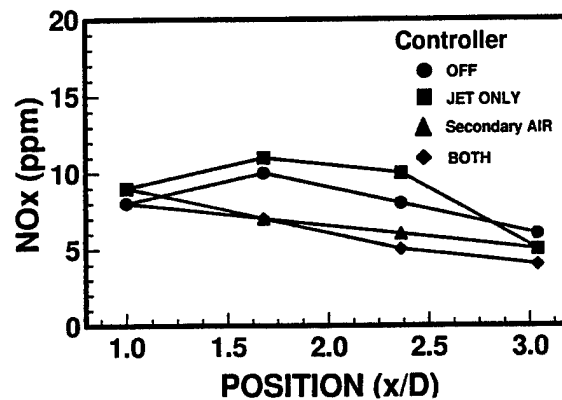

Fig. 6 NO<sub>x</sub> vs. downstream distance.

The performance of version 5 was not associated with the geometry alone; either driven or self-excited oscillations, i.e. vorticity, was required for good performance. Under conditions where the self excitation did not start the CO levels were very high: up to 600 ppm (at x/D = 3.1) depending on the exact geometry of the waste injection. When self

excitation did not occur the controller worked best with both central air forcing and secondary air forcing at the proper phase angle (Fig. 7).

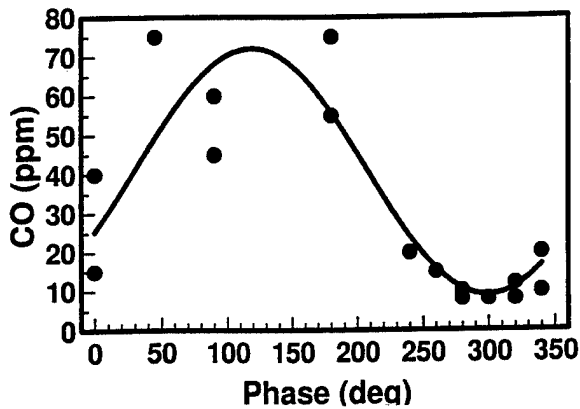

Fig. 7 CO ppm versus phase angle for the actively controlled combustor under conditions without self excitation.

In the version 5 geometry the waste surrogate is injected into the shear layer at 15 degrees to the central air flow but the secondary air comes in at 90 degrees. Another version was designed and constructed, version 6, which introduced the secondary air at a shallower angle. It was thought that this would lead to less disturbance of the shear layer and incipient vortex formation process.

Version 6 was even more susceptible to self excitation than version 5 and the controller had little or no effect on the performance. The DRE exceeded 4.5 to 5 nines at  $x/D = 3.1$ , and 4 nines at  $x/D = 2.36$ , independent of the state of the controller (on or off). The emissions performance of version 6 was similar to version 5: the CO at  $x/D = 2.36$  was about 75 ppm except for the rare occasions the self excitation stopped, in which case the CO rose rapidly past 500 ppm.

The self excitation seen in versions 5 and 6 mean that it would be possible to construct an actively controlled vortex combustor with little or no electrical input power. This would probably require a closed feedback loop with minimal acoustic forcing to keep the system oscillating in a stable manner given changes in input flow rate and fuel heat content. Such

experiments are planned for the future with an acoustic sensor coupled via a filter and phase shift controller powering the acoustic drivers of the secondary air flow.

### NOx Reduction

The active vortex combustion control basically works by rapidly mixing the fuel and air of an annular diffusion flame while delaying combustion via high stretch in the vortex braid region. This means the combustion is much closer to premixed than diffusional. This leads to dramatic reduction of soot formation, lowered CO and UHC emissions, and increased DRE. It could also be predicted that it would lead to NOx reduction for fuel to air ratios away from stoichiometric. This is because the temperature of a premixed lean (or rich) flame is less than regions in diffusion flames where the local stoichiometry reaches that for maximum temperature (usually near fuel to air ratios of 1.0).

To further study the NOx reduction capabilities of the actively controlled vortex combustion technology at a wide range of stoichiometries, experiments using the stack gas analyzer in the enclosed burner were undertaken. The 5 kW laboratory version of the afterburner simulator was used for expediency.

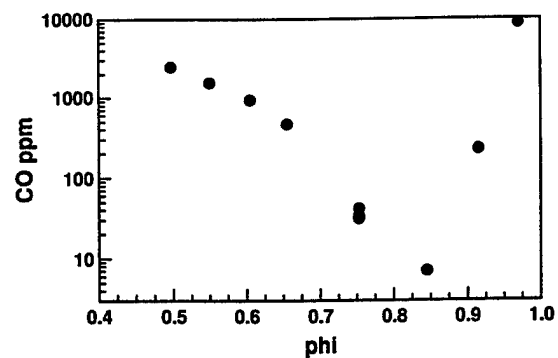

Fig. 8 CO ppm of controlled flame as a function of fuel to air stoichiometry in the 5 kW burner.

Figure 8 shows that the reduction of CO was dependent on fuel to air ratio with the minimum CO occurring at a  $\Phi = 0.75$ . The CO rises very sharply as  $\Phi$  approaches 1.0. It also

rises at low  $\Phi$  as the flame becomes less stable in this burner configuration.

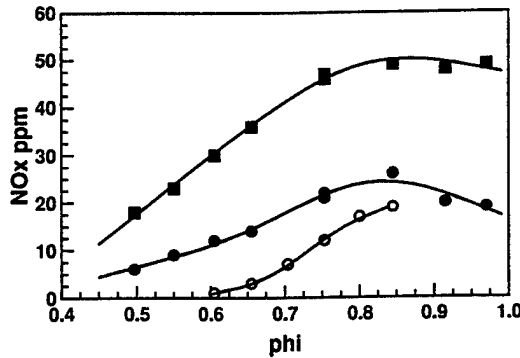

Fig. 9 NOx vs. fuel to air stoichiometry for the controller off (■), on at 11 volts (●), and on at 22 volts (○).

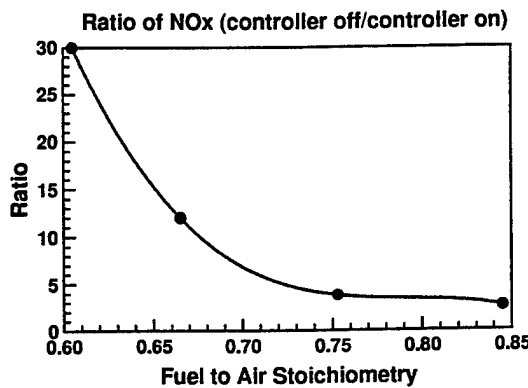

Fig. 10 Ratio of NOx ppm for controller off to controller on (22 V) versus fuel to air stoichiometry.

Figure 9 shows that the NOx levels are  $\Phi$  dependent and that, as expected, lean flames have much lower NOx. The reduction of NOx is much larger at low  $\Phi$  as shown in Fig. 10: reductions of up to a factor of 30 can be reached at  $\Phi = 0.605$  for the maximum forcing level on the controller. NOx levels as low as 1 ppm (the detection limit of our sensor) were seen under these conditions (almost all of the NOx under nearly all the conditions is from NO). It should be noted that at the low  $\Phi$  levels that minimize NOx the flame is somewhat less stable and the CO is not optimized. The stoichiometry operating limits of the 50 kW and Mega-Watt scale combustors has not been studied. Nevertheless, the active control vortex

combustor shows considerable promise as a low NOx diffusion combustor.

### Mega-Watt Scale Tests

Since the active combustion control methodologies developed at the 5 kW laboratory scale had been successfully scaled up to the 50 kW level, a logical extension was to scale further to the 500 kW to 1 MW level that is essentially full scale for the envisioned compact shipboard waste incinerator.

This work started with free jet tests at China Lake. The central air jet diameter was 66.3 mm and the velocity was approximately 45 m/sec. This followed the previous technique of scaling an order of magnitude via a square root of 10 increase in velocity with a square root of ten increase in area. The velocities of the secondary air and waste surrogate streams were also scaled up by the same factor. The Reynolds number for the central air jet was 200,000; over five times the value for the 50 kW tests (39,000). The preferred mode of the jet occurs at 300 Hz (for a Strouhal number of 0.44).

The free jet combustion consumed 26 gm/sec of ethylene waste surrogate (not including the nitrogen) which is 2.4 tons per day. (No benzene was used in the Mega-Watt scale tests.) This feed rate is high enough to handle a medium sized Navy vessel. A carrier would require 3 or 4 of this scale incinerator, but the success in scaling to the present level indicates that another factor of three should be attainable.

The power level for the free jet tests was approximately 1.2 MW. The fuel to air stoichiometry for these tests was quite high (up to 2.0) but because it was a free jet a lot of extra air is entrained from the surroundings.

The high mass flow of secondary air caused a slight back pressure (about 0.25 PSIG) in the plenum and this reduced the efficiency of the acoustic drivers by pinning the diaphragms against the stop for parts of the acoustic cycle. Therefore the tests were not optimized and the

secondary air forcing had little effect (as evidenced by the lack of any phase angle effect). Future work will be done with wider gaps or back pressure equalization on the speakers.

Nevertheless, the acoustic forcing of the central air flow was obviously able to create a strong vortex controlled flame. The free jet tests investigated three different configurations: a gas burner (GB) where the acoustically modulated waste surrogate (ethylene) was introduced between the central air jet and the surrounding (non modulated) secondary air flow; and two versions of an afterburner configuration, one matching the baseline configuration discussed above for the 50 kW burner (version 3F), and another matching the

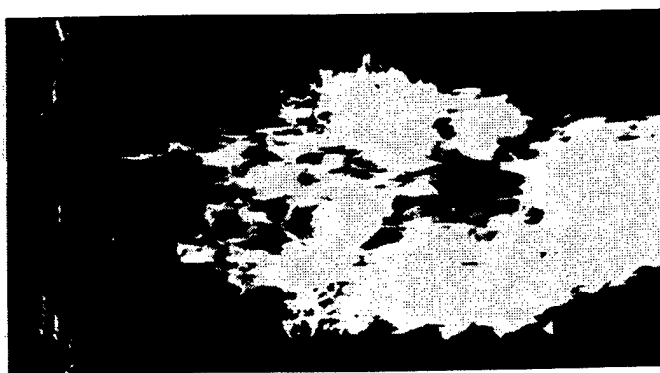

Fig. 11 Scan of color photo of MW level free jet combustor in uncontrolled mode. Most of the image is yellow. The dark image to the left is the combustor and flow is to the right.

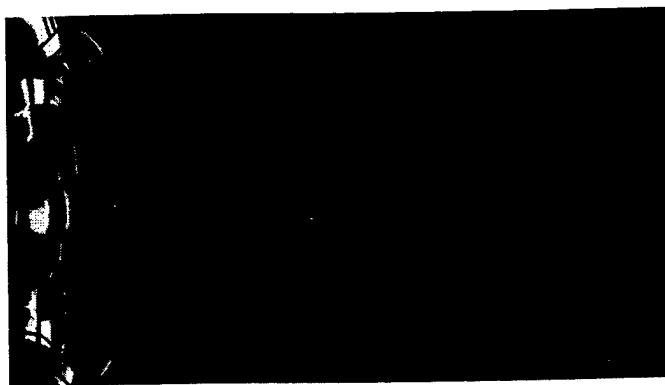

Fig. 12 Same image with controller on. The exposure is longer as evidenced by the clear image of the combustor at the left. The faint blue flame does not scan well in gray scale.

version discussed last year (20) which internally mixed the waste and secondary air flows and directed both into the shear layer at 15 degrees off parallel (version 4A).

In the free jet tests the only diagnostic was the appearance of the flame and in all cases turning on the controller caused the uncontrolled flame, which was long and yellow, to become shorter and essentially entirely blue. In past work at 5 and 50 kW the unforced flame, with very low DRE and high emissions, was always yellow while the forced flame, with high DRE and low emissions, was blue.

Figure 11 shows the uncontrolled GB MW burner flame. The flame is entirely yellow. Figure 12 shows the controlled flame under the same conditions as Fig. 11: the weak flame image is due to blue flame chemiluminescence rather than the strong soot incandescence seen in Fig. 11. The flow was forced at the preferred mode of the central air jet, which, due to the higher velocity and larger diameter, is at 300 Hz. The images (clearer in color than here in black and white) show that the controller creates a strong vortex, very fast mixing (as show by rapid shear layer expansion), and a lifted partially premixed flame. The heat release has clearly moved upstream, potentially leading to a more compact afterburner.

As with previous 50 kW combustors it was found that the optimum waste jet introduction velocity was at or somewhat below the central air average velocity. In tests done with the waste entrainment jet velocity (3F configuration) at 82 or 55 m/sec, the controlled flame was entirely blue. However, with a waste velocity of 27 m/sec some yellow appeared, and a waste velocity of 20 m/sec gave quite a lot of yellow in the controlled flame. These velocities compare with the central air jet velocity of 45 m/sec. In all cases the waste mass flow rate was unchanged; the velocity was changed by varying the injection area (gap thickness).

Quantification of the performance was desired, but China Lake did not have on hand the capability to enclosed such a large energy

release rate (2.1 MBtu/hr not counting the extra fuel burnt in the free jet tests by entrained ambient air). Therefore another burner was constructed at EER Corp. and attached to their package boiler facility for emissions tests. This burner was based directly on the China Lake design with some modifications: the secondary air issued from a circular slot rather than multiple holes along circumference but the area was matched, the entrainment plate was water cooled, the waste mixture injection angle was about 60° vs. 90°, and the central air jet velocity was somewhat lower (32 m/sec) leading to a lower preferred mode (about 220 Hz). The ID of the package boiler (i.e. dump area) was 0.59 m. Most of these changes were necessitated by integration with the package boiler. The firing rate was about 380 kW.

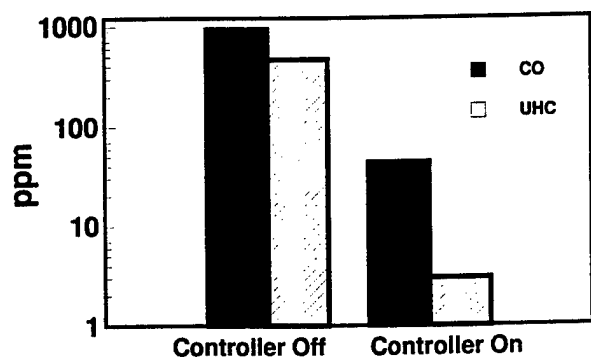

Fig. 13 Effect of active control on CO and UHC levels for 380 kW enclosed afterburner. Note the logarithmic scale.

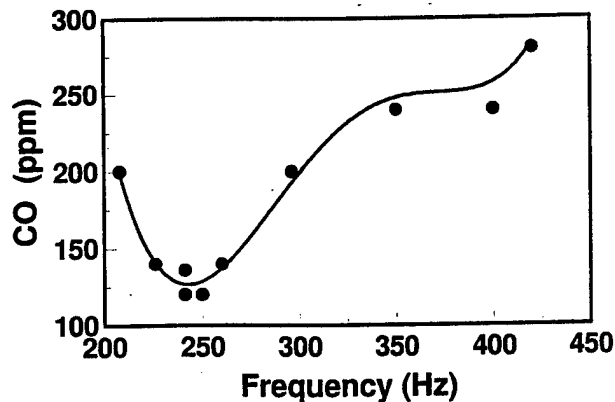

Fig. 14 Effect of forcing frequency on CO emissions from 380 kW enclosed afterburner. The minimum emissions occur at the preferred mode of the air jet.

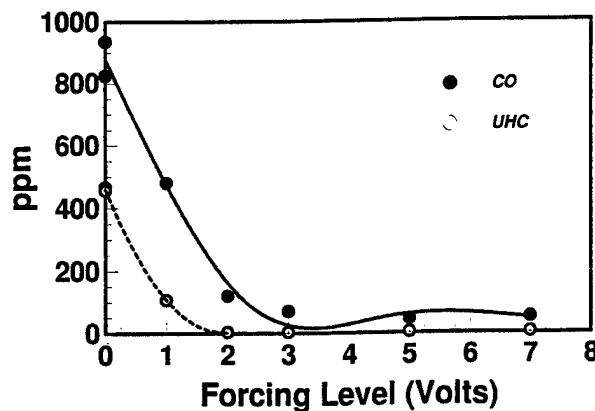

Fig. 15 Effect of forcing level on CO and UHC emissions (uncorrected for O<sub>2</sub>%).

The tests showed clearly that the controller greatly improved performance. Figure 13 shows that the use of active acoustic control greatly reduced the CO and UHC emissions. The CO dropped from 880 ppm (uncorrected for O<sub>2</sub>%) down to 44 ppm, a factor of 20x, and the UHC from 460 ppm down to 3 ppm, a factor of over 150x. In these tests the central air flow was forced at 241 Hz, very near its preferred mode.

Figure 14 shows that this was an optimal frequency. The drop in emissions with increasing controller forcing level was sharp. Figure 15 shows that most of the reduction is realized with only 2 volts on the Ling™ modulator. This means that the 380 kW burner is being controlled with only 1.6 watts of electrical power.

The speakers driving the secondary air were apparently adversely affected by back pressure and had little or no effect on the control. Figure 16 shows that the relative phase angle between the central air vortex shedding and the secondary air forcing had almost no effect. The tests were done at overall fuel to air stoichiometry levels between 0.63 and 0.8. Figure 17 shows that the CO levels were lowest for leaner conditions. The unburned hydrocarbons were below the detection limit for all stoichiometries tested (with the controller on).

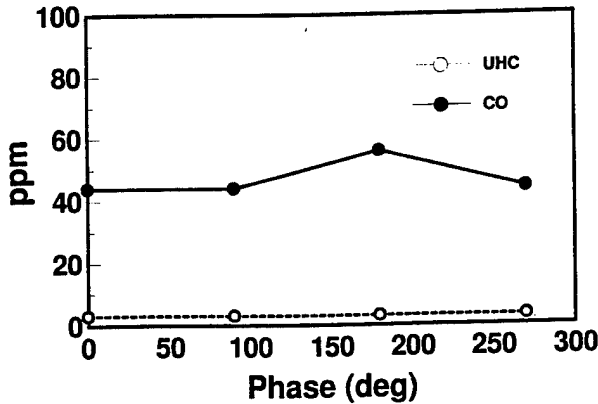

Fig. 16 Effect of relative phase angle between main and secondary air forcing on emissions.

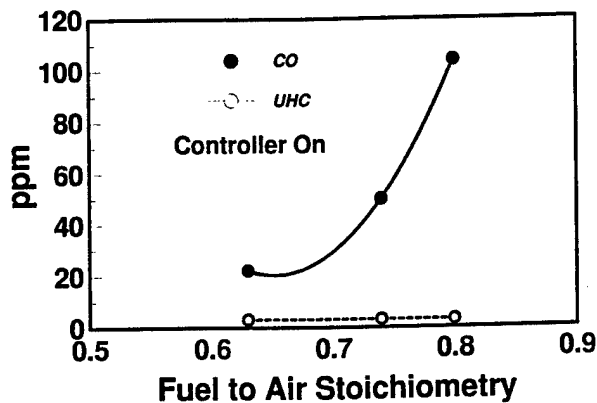

Fig. 17 CO and UHC emissions versus fuel to air stoichiometry for the actively controlled 380 kW combustor. Stoichiometry calculation includes secondary air.

**CONCLUSIONS**

Active control of fluid dynamics has been used to enhance mixing in incinerator afterburner experiments and increase the DRE for a waste surrogate. Experiments were conducted at 50 kW and mega-Watt power scales.

The open loop active control system is based on the concept of combustion in periodic axisymmetric vortices. Acoustic excitation was used to stabilize coherent vortices in the central air flow of a dump combustor like configuration. The fuel and waste are injected annularly at the dump. The phase angle of forcing is controlled such that the combustibles are introduced into the air vortex at the optimal time during the vortex formation. This leads to good mixing, a controlled yet lifted

partially premixed flame, high DRE and low emissions.

The geometry of the introduction of the waste surrogate and secondary air flow into the main air flow vortex shedding point was varied. Experiments were done with the waste surrogate annular injection sandwiched between the forced main and secondary air flows as well as with it outside the secondary air injection annulus. In addition, the angle of injection of the waste surrogate and secondary air into the main air shear layer was varied between 80 and 15 degrees. In all cases the performance of the system could be optimized at approximately the same level (as indicated by benzene DRE or CO and UHC emissions). This shows the versatility of the technique to handle geometric constraints. In addition, some configuration were self-exciting indicating the possibility of active combustion control with extremely low electrical power.

Further study of the NOx reduction potential of this active control indicated that NOx reductions as high as 30x were possible for lean stoichiometries. As richer stoichiometries were approached the NOx reduction became much less. The strong vortex forcing of the active control technique creates a partially premixed flame that is held off the dump plane by the high strain rates in the vortex roll up region. A partially premixed lean flame will be colder than regions of a similar lean diffusion flame, thereby leading to lower NOx production.

The same design principles used in the 50 kW scale combustor were applied to a 1.2 MW free jet version (China Lake), as well as a 400 kW scale enclosed version (at EER Corp.). The active control was still effective at these power levels despite the much higher Reynolds number. In the free jet tests (1.2 MW) activation of the controller changed a long yellow flame to a shorter all blue flame. In enclosed tests (400 kW at EER) the controller reduced the CO emissions by a factor of over 20 and UHC emissions by a factor of over 150.

It is clear that this vortex combustion technology is scalable and has wide

applicability for use in afterburners for incinerators as well as low NO<sub>x</sub> gas combustors.

**REFERENCES**

1. S.C. Crow and F.H. Champagne, "Orderly Structure in Jet Turbulence", *J. Fluid Mech.*, 48, pp. 545-591, 1971.
2. G.L. Brown, and A. Roshko, "On Density Effects and Large Structure in Turbulent Mixing Layers", *J. Fluid Mech.*, 64, pp. 775-816, 1974.
3. C.M. Ho, and P. Huerre, *Ann. Rev. Fluid Mech.*, 16, pp. 365-424, 1984.
4. D. Oster, and I. J. Wygnanski, "The Forced Mixing Layer Between Parallel Streams", *Fluid Mech.*, 123, pp. 91-130, 1982.
5. C.M. Ho, and L.S. Huang, "Subharmonics and Vortex Merging in Mixing Layers", *J. Fluid Mech.*, 119, pp. 443-473, 1982.
6. R.K. Hanson, "Combustion Diagnostics: Planar Imaging Techniques", 21st Int. Symp. on Combustion, pp. 1677-1691. Pittsburgh: The Combustion Institute, 1986.
7. E.J. Gutmark, T.P. Parr, D.M. Hanson-Parr, and K.C. Schadow, "On the Role of Large and Small-Scale Structures in Combustion Control", *Combustion Science and Technology*, 66, pp. 107-126, 1989.
8. S. Candel, 24th Int. Symp. On Combustion. Pittsburgh: The Combustion Institute, 1992.
9. K.R. McManus, T. Poinsot, and S. Candel, "A Review of Active Control of Combustion Instabilities", *Progress in Energy and Combustion Science*, 19, pp. 1-29, 1993.
10. K.R. McManus, U. Vandsburger, and C.T. Bowman, "Combustor Performance Enhancement through Direct Shear Layer Excitation", *Combustion and Flame*, 82, pp. 75-92, 1990.
11. K. Yu, A. Trouve, and S. Candel, "Combustion Enhancement of a Premixed Flame by Acoustic Forcing with Emphasis on the Role of Large Scale Vortical Structures", AIAA Paper No. 91-0367, 1991.
12. E.J. Gutmark, K.J. Wilson, K.C. Schadow, B.E. Parker, R.L. Barron, G.C. and Smith, "Dump Combustor Control Using Polynomial Neural Networks (PNN)", 31st AIAA Aerospace Sciences Meeting, Reno, NV, AIAA Paper No. 93-0117, 1993.
13. K.T. Padmanabhan, C.T. Bowman, J.D. Powell, "An Adaptive Optimal Combustion Control Strategy", 25th Int. Symp. on Combustion, Pittsburgh: The Combustion Institute, 1994.
14. L. Chen, V.G. McDonell, and G.S. Samuelson, WSS/CI Fall Meeting, Paper No. 92-75, 1992.
15. O.I. Smith et. al., "Incineration of Surrogate Wastes in a Low Speed Dump Combustor", *Comb. Sci. and Tech.* 74, 199 (1990).
16. R. Marchant et. al. "Development of a Two-Dimensional Dump Combustor for the Incineration of Hazardous Wastes", *Comb. Sci. and Tech.* 82, 1 (1992).
17. K.C. Schadow, E.W. Hendricks, and R. J. Hansen, "Recent Progress in the Implementation of Active Combustion Control", 18th ICAS Congress, Beijing, China, September 1992.
18. C.C. Lee, G.L. Huffman, and S.M. Sasseville, "Incinerability Ranking Systems for RCRA Hazardous Constituents", *Hazardous Waste and Hazardous Materials*, Vol. 7, (1990).
19. T.P. Parr, E. Gutmark, K.J. Wilson, K. Yu, R.M. Smith, D.M. Hanson-Parr, and K.C. Schadow, "Actively Controlled Compact Waste Incinerator", Proceedings of the 1995 International Incineration Conference, pages 247-254.
20. T.P. Parr, K.J. Wilson, K. Yu, R.A. Smith, and K.C. Schadow, "Actively Controlled Compact Waste Incinerator", Proceedings of the 1996 International Incineration Conference, pages 787-793.