LABORATORY INVESTIGATION OF SCOUR AROUND BRIDGE PIERS

**MRD HYDRAULIC LABORATORY SERIES
REPORT NO. 14**

**MEAD HYDRAULIC LABORATORY
MEAD, NEBRASKA**

DISTRIBUTION STATEMENT A
Approved for Public Release
Distribution Unlimited



**US Army Corps
of Engineers**
Missouri River Division

19990525 062

REPORT DOCUMENTATION PAGE			Form Approved OMB No. 0704-0188	
Public reporting burden for this collection of information is estimated to average 1 hour per response, including the time for reviewing instructions, searching existing data sources, gathering and maintaining the data needed, and completing and reviewing the collection of information. Send comments regarding this burden estimate or any other aspect of this collection of information, including suggestions for reducing this burden, to Washington Headquarters Services, Directorate for Information Operations and Reports, 1215 Jefferson Davis Highway, Suite 1204, Arlington, VA 22202-4302, and to the Office of Management and Budget, Paperwork Reduction Project (0704-0188), Washington, DC 20503.				
1. AGENCY USE ONLY (Leave blank)	2. REPORT DATE September 1982	3. REPORT TYPE AND DATES COVERED		
4. TITLE AND SUBTITLE Laboratory Investigation of Scour Around Bridge Piers			5. FUNDING NUMBERS	
6. AUTHOR(S)				
7. PERFORMING ORGANIZATION NAME(S) AND ADDRESS(ES) mead Hydraulic Laboratory mead, Nebraska			8. PERFORMING ORGANIZATION REPORT NUMBER	
9. SPONSORING/MONITORING AGENCY NAME(S) AND ADDRESS(ES) Omaha District, Corps of Engineers 215 N. 17th St. Omaha, NE 68102			10. SPONSORING/MONITORING AGENCY REPORT NUMBER MRD Hydraulic Laboratory Series No. 14	
11. SUPPLEMENTARY NOTES U.S. Army Engineer District, Kansas City, MO Missouri River Division				
12a. DISTRIBUTION/AVAILABILITY STATEMENT The report has been approved for public release and sale; its distribution is unlimited			12b. DISTRIBUTION CODE	
13. ABSTRACT (Maximum 200 words) This report presents model study results of proposed riverbed stabilization in the vicinity of bridge piers for the Illinois Central Gulf railroad bridge (formality formerly the Illinois Central Railroad) (IC) spanning the Missouri River near Omaha, NE The objective of study was to determine the effects on the down stream channel of stabilization of the bed around a bridge pier.				
14. SUBJECT TERMS riverbed stabilization bridge piers Missouri River			15. NUMBER OF PAGES 6	
			16. PRICE CODE	
17. SECURITY CLASSIFICATION OF REPORT Unclassified	18. SECURITY CLASSIFICATION OF THIS PAGE Unclassified	19. SECURITY CLASSIFICATION OF ABSTRACT Unclassified	20. LIMITATION OF ABSTRACT	

SEP 1982

DEPARTMENT OF THE ARMY
CORPS OF ENGINEERS

Laboratory Investigation
of
Scour Around Bridge Piers

Conducted at
Mead Hydraulic Laboratory
Mead, Nebraska

U.S. Army Engineer District, Omaha, Nebraska
U.S. Army Engineer District, Kansas City, Missouri
Missouri River Division, Omaha, Nebraska

TABLE OF CONTENTS

	<u>Page</u>
1. List of Plates	i
2. List of Photographs	ii
I. Introduction	1
II. The Model	1
III. Operating Procedures	2
IV. Test Procedures	2
V. Model Verification	3
VI. Conclusion	4
References	
Appendix A - Plates	
Appendix B - Photographs	

LIST OF PLATES

Plate No.	Description
1	Center pier of Illinois Central Gulf Railroad bridge used for prototype
2	Bed contour map around center pier of Illinois Central railroad bridge from sounding of 30 May 1973
3	Location of bridge pier on Missouri River
4	Bar formation downstream of bridge piers

PIER STUDY

List of Photographs

1. Photo 1 - Run 11 looking from the left bank showing bed configuration at end of run with 1:25 horizontal scale pier at 25° angle to the flow.
2. Photo 2 - Run 12 looking downstream showing stone blanket flush with bed (elevation 1.2) before run was started.
3. Photo 3 - Run 13 looking upstream showing bed configuration at the end of run. Bed armor around pier placed at elevation 1.0 or 0.2' below bed. Note scour down to stone and bar d/s of pier.
4. Photo 4 - Run 23 looking downstream showing bed configuration at end of run. Bed armor placed at elevation 1.1 or 0.1 below bed level. Note large bar behind pier and exposed stone.
5. Photo 5 - Run 25 looking downstream showing bed configuration at end of run. Bed armor placed at same elevation as Run 23 (Photo 4) but with velocity increased. Note deep scour on right with large bar behind pier. No failure of stone occurred.

PIER STUDY

I. Introduction

1. Report Topic. This report presents model study results of proposed riverbed stabilization in the vicinity of bridge piers for the Illinois Central Gulf railroad bridge (formerly the Illinois Central Railroad) (IC) spanning the Missouri River near Omaha, Nebraska.

2. Study Location and Personnel Involved. The study was conducted at the Mead Hydraulic Laboratory near Mead, Nebraska, by personnel of the Hydraulics Section of the Omaha District Corps of Engineers. The engineer in charge of the facility was R. A. Singleton who was assisted by technicians E. E. Matson and W. J. Howard. The study was performed under the general supervision of the Missouri River Division Corps of Engineers. The actual period of testing was from 10 October 1973 to 30 January 1974. This report was prepared by Mr. Matson and edited by Mr. Robert Buchholz.

3. Problem Definition. Navigation interests on the Missouri River have been plagued periodically by the development of sandbars which extend into navigation lanes downstream of bridge piers. The Illinois Central Gulf (ICG) railroad bridge is located in a reach downstream of a sharp bend on the Missouri River at River Mile 618.3 where downstream shoals have developed in the past. Although it is contended that the bridge piers cause the formation of the bars, it is not known how the presence of the scour holes adjacent to the piers affect the downstream shoal formations. A model study of a bridge pier in the Mississippi River, for which this problem had been experienced, was conducted at the St. Anthony Falls Hydraulic Laboratory¹. The report concluded that the most practical means of eliminating obstructing deposition, in the navigation channel below the bridge, was to stabilize the riverbed adjacent to the base of the bridge piers. Based on the St. Anthony Falls report, stabilization of the bed around the ICG railroad bridge pier near Omaha was proposed. The applicability of the report, however, was questioned by the Missouri River Division, and a model study of the problem was proposed.

4. Objective of Study. The objective of the model study was to determine the effects on the downstream channel of stabilization of the bed around a bridge pier.

II. The Model

5. Description of Study Reach. Plate 1 shows the middle portion of the IC railroad bridge which spans the Missouri River. The left river bank is fully revetted with stone and forms a stabilized boundary. The Missouri River has an average width of 600 feet in this reach. The prototype bridge pier is at an angle of 13° to the flow direction. Soundings taken on 30 May 1973, in the area around the center pier of the ICG railroad bridge and hydrographic survey maps of the reach, were used for verification of model runs. The bed contour map around the center pier of the ICG railroad bridge, depicting results of the 30 May 1973 soundings, is shown on Plate 2.

6. A very simple model was constructed to study the pier scour problem. Horizontal and vertical scales of 1:25 and 1:50, respectively, were selected. At this scale only half of the channel width was modeled. The model did not take into account the upstream and downstream bends. Skew angles of 13°, 25°, and 45° to the flow direction were modeled. Plate 3 shows the prototype pier location on the Missouri River.

7. Table 1 presents model-to-prototype scale factors and gives some observed model values for depth and velocity.

Table 1

Model to Prototype Scale Ratios

Horizontal scale	1:25
Vertical scale	1:50
Velocity	1:7.07
$\frac{L}{L}$ Model depth: $\frac{L}{L}$ Prototype depth (ft)	0.29:14.5
$\frac{V}{V}$ Model velocity: $\frac{V}{V}$ Prototype velocity (fps)	0.85:6.0*

*Reference 2

III. Operating Procedures

8. The basin, in which the model was constructed, consisted of a completely closed system in which the water and bed material were continuously recirculated. The bed material consisted of finely ground walnut shells. At various times during selected runs, the circulation of water through the model was stopped in order to make channel soundings that were used to plot the width and depth of the section. Photographs of the model were taken at the end of each run. MRD Hydraulic Laboratory Report No. 1 provides a more detailed description of the bed material and operating procedures used at the Mead Hydraulic Lab.

IV. Test Procedures

9. Types of Tests Run. Several runs were made for the condition of no bridge pier in the model before the verification runs were started in order to obtain a uniform bed that would establish uniform flow distribution and assure uniform average depth in the model. Once a uniform bed was achieved, runs were made with the bridge pier in the model as follows:

- a. Verification runs were conducted.
- b. The bridge pier was set at different angles to the flow.
- c. Tests at different velocities and depths were made to determine their effect on the shoaling downstream.
- d. The bed around the pier was armored with stone set at different elevations.

V. Model Verification

Verification Runs:

10. Pier at 13° Angle Several runs were made to verify that the model was duplicating the conditions observed in the prototype. A pier was set in the model at an angle of 13° to the flow. The bed configuration, resulting from the verification runs, was very similar to that experienced in the prototype when compared to the soundings taken on 30 May 1973. However, no shoaling could be detected in the downstream channel.

11. Pier At 25° Angle. Since the 13° skew of the bridge pier was not providing easy identification of shoaling downstream of the pier, a 25° skew angle was tested. Four runs with the 25° skew angle produced scour adjacent to the pier similar to that observed in the prototype, with a small bar downstream of the pier. See Photo No. 1. Although the bar did not appear in the same location as in the prototype, the resulting bed configuration appeared to be representative of the prototype condition as a whole. Nine runs were conducted for various flow depths and velocities with the bridge pier at the 25° angle to the flow. However, the deposits downstream of the pier still did not form in the same location as the prototype. These bars, however, did form very rapidly at the beginning of the runs and dissipated as the runs continued.

12. 45° Angle Runs. One run was made with the bridge pier at an angle of 45° in order to observe the effects of the obstruction on the area downstream of the bridge pier. A large deposit appeared immediately behind the pier and extended downstream a considerable distance where it fanned out. The scour around the bridge pier was confined to the area in front and around both sides of the pier.

13. Discussion of Verification Runs. Overall, the verification runs adequately reproduced the prototype bed conditions around the ICG railroad bridge pier. The shoaling downstream of the bridge pier formed in a different location and the bar formation appeared to be transitory. Possible reasons why the bar formed in different locations in the model than in the prototype areas follows:

a. This was a simple idealized model, and no attempt was made to reproduce the prototype channel shape or structures.

b. Only 1/2 of the channel width was modeled.

c. The upstream and downstream bends were eliminated which could have caused a larger angle of attack affecting the location of the bars.

d. The flow distribution upstream and downstream of the bridge pier was not investigated, therefore, it is not known whether the flow distribution in the model was the same as in the prototype. This could cause the deposition pattern to be different in the model than in the prototype. Following are possible reasons why the bar was transitory in the model:

(1) The bar is probably transitory in the prototype, but because of the lightweight material in the model, the time scale is such that the bar dissipates rapidly before it can be identified.

(2) If the correct flow distribution had been achieved in the model, the bar may have dissipated at a somewhat slower rate.

14. Description - Armoring Around the Pier. Five runs were devoted to the determination of the effects of bed stabilization around a bridge pier. Three different elevations were used for placement of the stone around the pier. The proposed prototype stone blanket width and length of 60 feet x 90 feet was used. This was accomplished by armoring the area around the pier at bed level and 0.1 and 0.2 feet below bed level. See Photos Nos. 2, 3, and 4. Plots were made of the top of bar elevation vs. time of running the model for the bridge piers armored at the bed elevation, 0.2 feet below the bed elevation, and also, the unarmored bridge pier at equivalent prototype distances of 25, 75, and 175 feet downstream of the bridge pier (see Plate 4 figures 1-3).

15. Effects of Armoring. The armoring of the bed around the bridge pier restricted the scour depth to the elevation of the stone blanket and did not transfer the scour downstream beyond the edge of the blanket. In this respect, the armoring worked very well. However, the armoring of the bed resulted in a large deposit downstream of the bridge pier. When the stone blanket was placed at bed level, the deposit downstream of the pier increased with time, while the unarmored bridge pier caused a deposit that seemed to shrink with time as shown in Plate 4, figures 1-3. When the stone blanket was placed at 0.2 foot below bed level, the deposit was larger than the unarmored deposit but was less than that which occurred with the rock blanket at bed level. The armoring, at 0.2 foot below bed level, behaved more like the unarmored deposit in that the deposit diminished with time. As the scour depth is reduced, because of the stone armoring, the deflected current around the front of the pier is stronger, and there is a greater eddy area behind the bridge pier which resulted in a larger deposit behind the pier than for the condition of no armoring around the bridge pier. In addition, a scour hole around the front and sides of the pier developed.

VI. Conclusions

16. The scour around the bridge pier in the model was fairly representative of the scour occurring adjacent to the prototype bridge pier. However, the bar that occasionally develops in the prototype downstream of the bridge pier did not develop in the same location in the model. Possible reasons why the bar did not develop include:

- a. A very simple model was constructed.
- b. The model did not take into account the upstream and downstream bends in the river.
- c. Only one-half of the channel width was modeled.

d. The flow distribution upstream and downstream in the prototype was not modeled.

e. Meager verification data was available for the prototype.

The findings of this limited study indicate that armoring of the bed around the ICG railroad bridge or any bridge could create a large bar immediately downstream of the bridge (figure 3). The elevation, at which the stone is placed in relation to the bed elevation, has an effect on the magnitude of the downstream bar with the largest bar being formed when the stone is placed at bed level.

This model study was limited in scope, and verification of the bars forming downstream of the bridge could not be accomplished in the model. Therefore, the results of this study should be applied with caution to the prototype bridge. More specific model testing or investigative studies need to be obtained on the problem.

References

1. St. Paul District, CE, U. S. Army, St. Paul, Minnesota, "Mississippi River Channel Improvement at Smith Avenue Bridge, St. Paul, Minnesota;" Hydraulic Model Investigation by Franklin J. Ryder, June 1981. Hydraulic Laboratory Report No. 72.
2. U. S. Army Engineer District, Omaha, Nebraska, CE, "Missouri River Navigation Channel Velocity Trends," June 1971.

APPENDIX A

PLATES

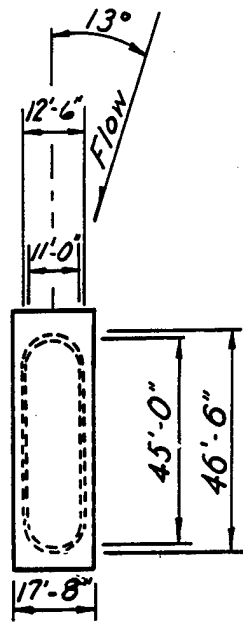

PLAN VIEW

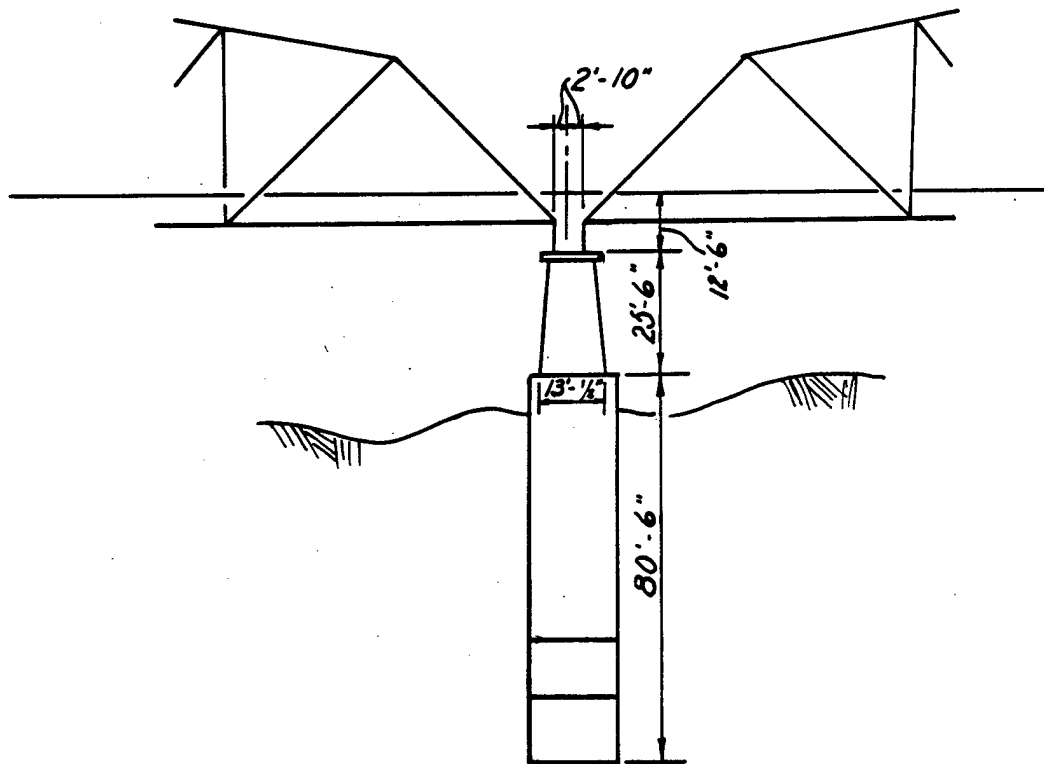

ELEVATION VIEW

MEAD HYDRAULIC LABORATORY
 PIER SCOUR STUDY
 PIER DETAIL

U. S. ARMY ENGINEER DISTRICT, OMAHA
 CORPS OF ENGINEERS OMAHA, NEBRASKA

IOWA

—12—10—10—9—11—14—12—13

12 14 13

15 16 17 18

—9—9—9—10—15—14—15

10 13 16 17

—12—10—15—16—19—18—18

13 16 19 20

ICRR BRIDGE PIER

—13—12—13—13—14—15—16—17—18—19—20—21—22—23—21—20

10 11 12 13 14 15 16 17 18 19 20 21 22 23 21 20

—16—14—15—18—16—18—17—14

15 17 20 21 22 20 19

—14—14—17—19—20—18—18

15 17 14 15 16 17 18

—14—13—15—17—16—18

15 16 17 18 19 20 21 22 20 19

—14—13—15—17—16—18

15 16 17 18 19 20 21 22 20 19

—14—13—15—17—16—18

15 16 17 18 19 20 21 22 20 19

—14—13—15—17—16—18

15 16 17 18 19 20 21 22 20 19

—14—13—15—17—16—18

15 16 17 18 19 20 21 22 20 19

—14—13—15—17—16—18

15 16 17 18 19 20 21 22 20 19

—14—13—15—17—16—18

15 16 17 18 19 20 21 22 20 19

MEAD HYDRAULIC LABORATORY

PIER SCOUR STUDY

MAY 1973 - SOUNDINGS

Q=33,000 C.F.S.-C.R.P. EL.969.2

U. S. ARMY ENGINEER DISTRICT, OMAHA, NEBRASKA

NEBRASKA

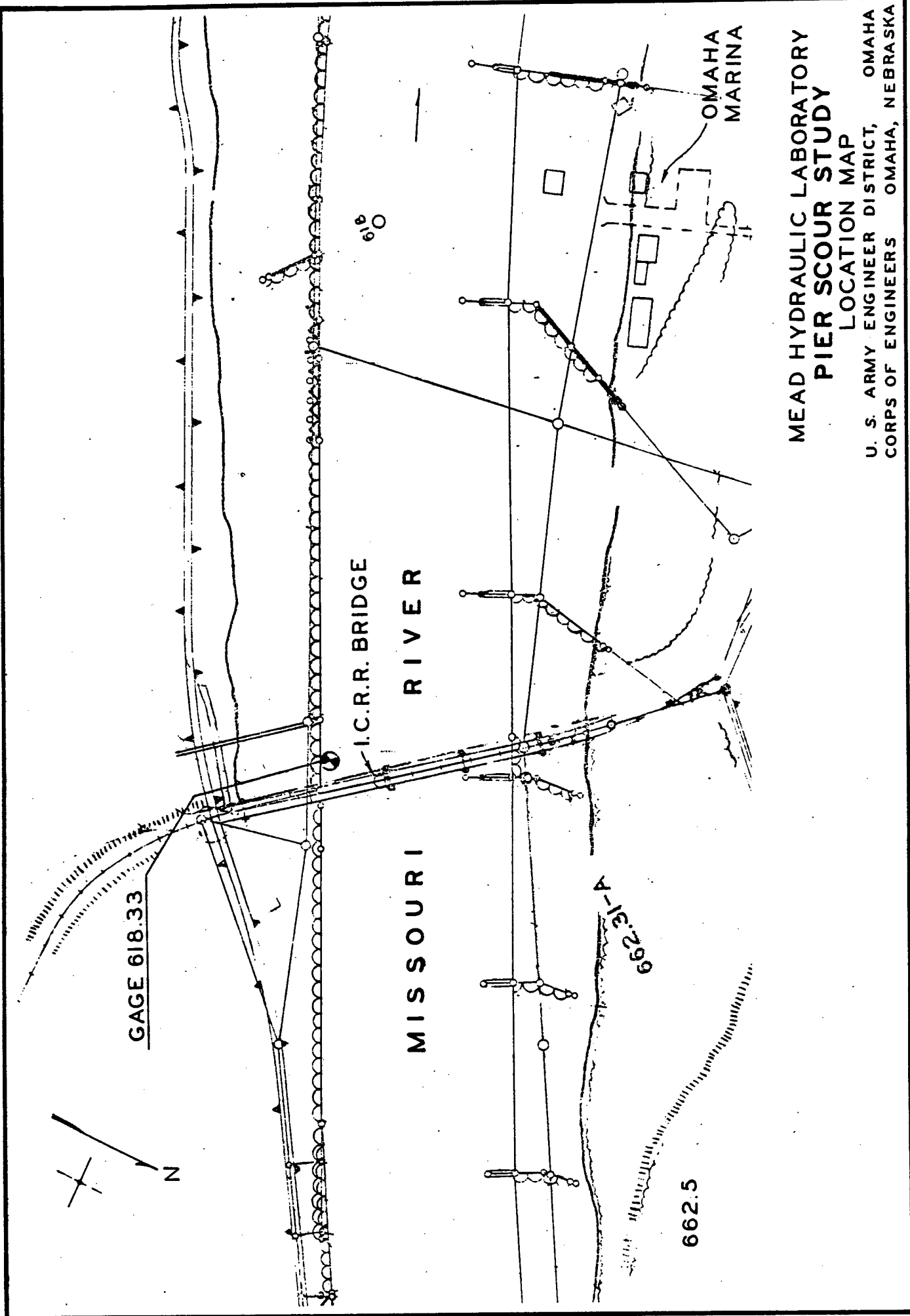

MEAD HYDRAULIC LABORATORY
PIER SCOUR STUDY
 LOCATION MAP
 U. S. ARMY ENGINEER DISTRICT, OMAHA
 CORPS OF ENGINEERS OMAHA, NEBRASKA

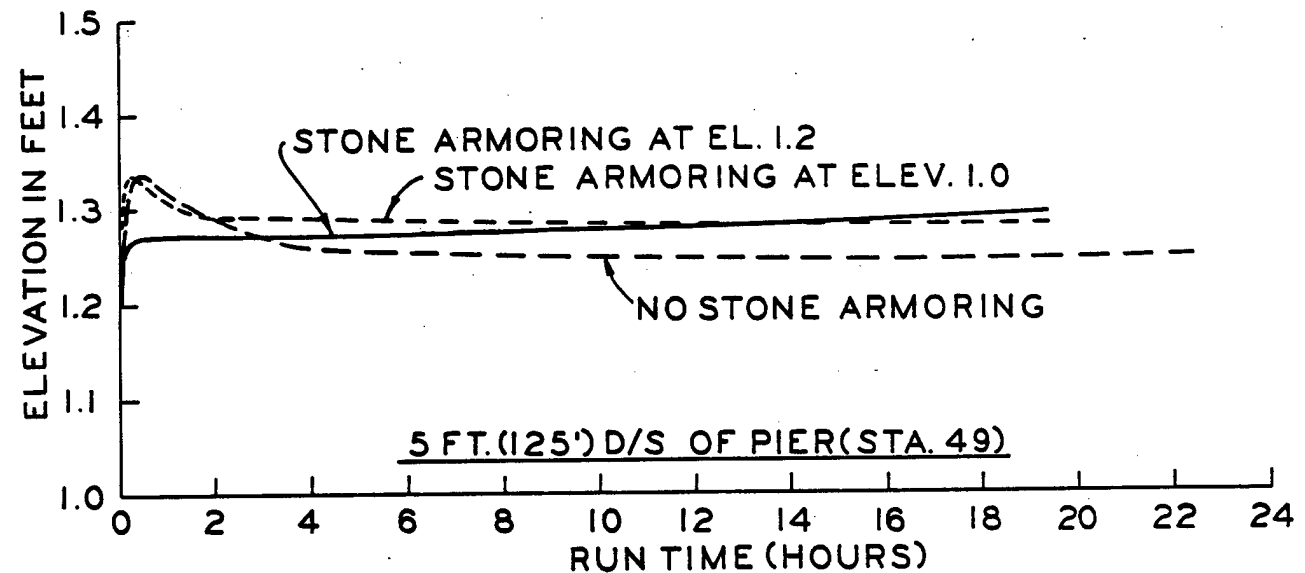
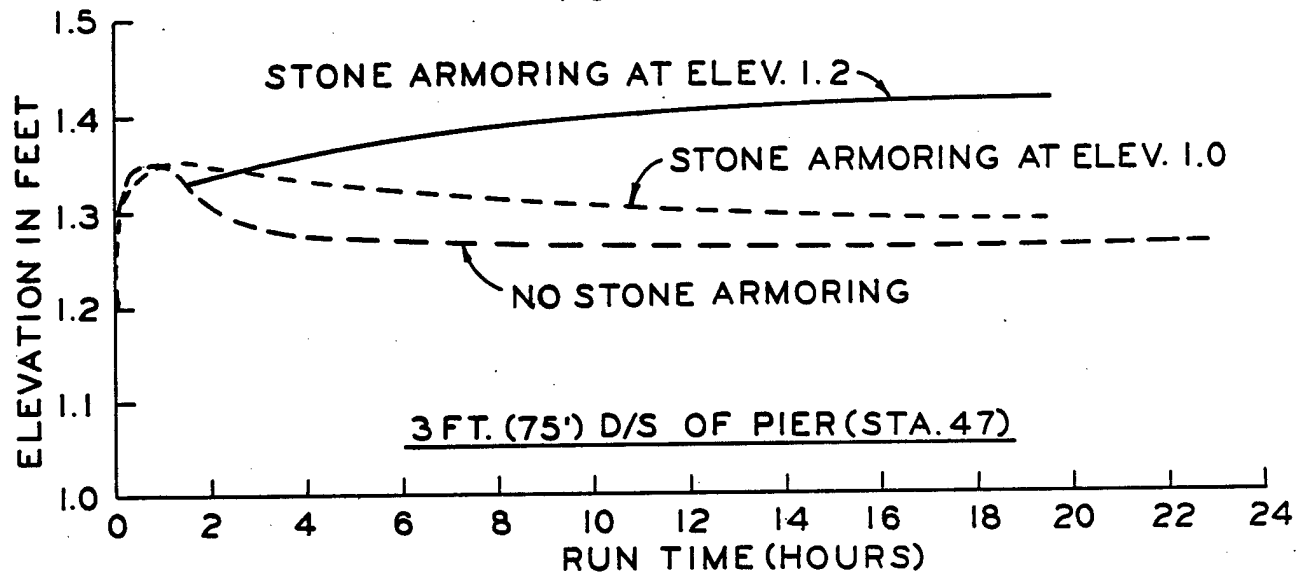
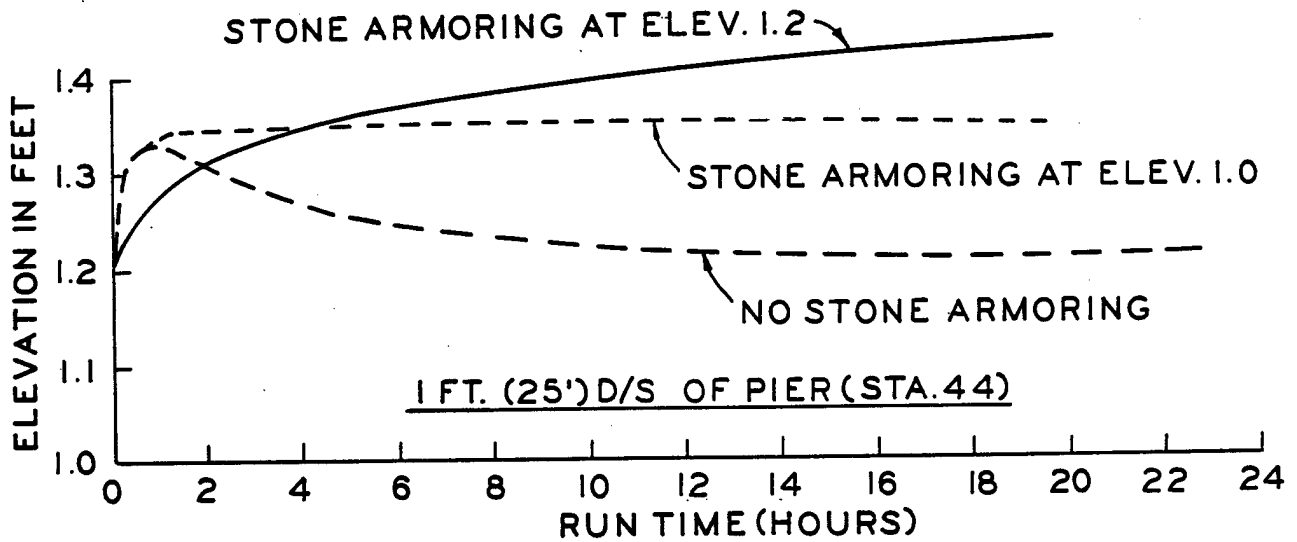

NOTE: 1.0 = NORMAL BED LEVEL

MEAD HYDRAULIC LABORATORY
 PIER SCOUR STUDY
 BAR FORMATIONS
 U. S. ARMY ENGINEER DISTRICT, OMAHA
 CORPS OF ENGINEERS OMAHA, NEBRASKA

APPENDIX B

PHOTOS

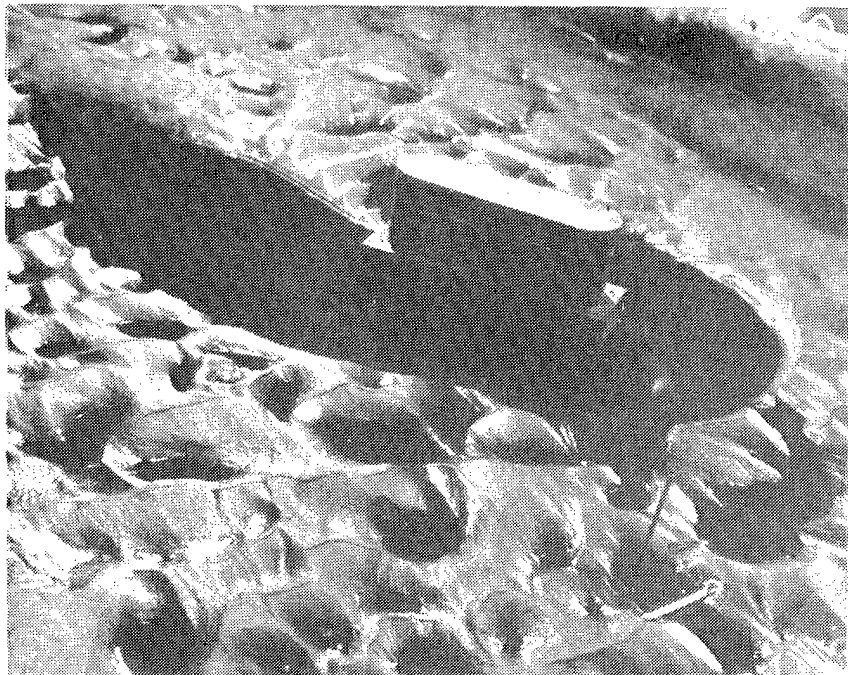

Photo 1. Run 11 looking from the left bank showing bed configuration at the end of run with pier at 25° angle to the flow.

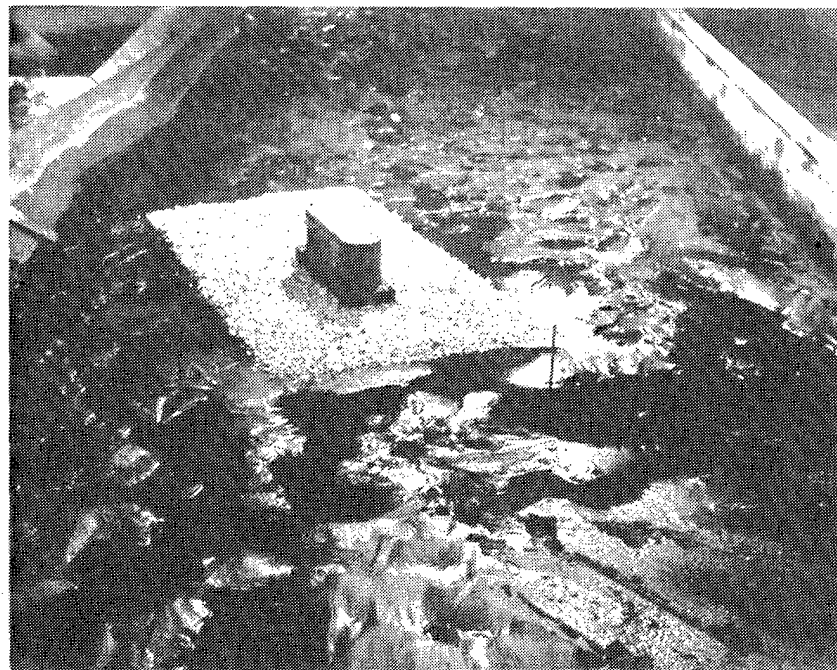

Photo 2. Run 12 looking downstream showing stone blanket flush with bed (elevation 1.2) before run was started.

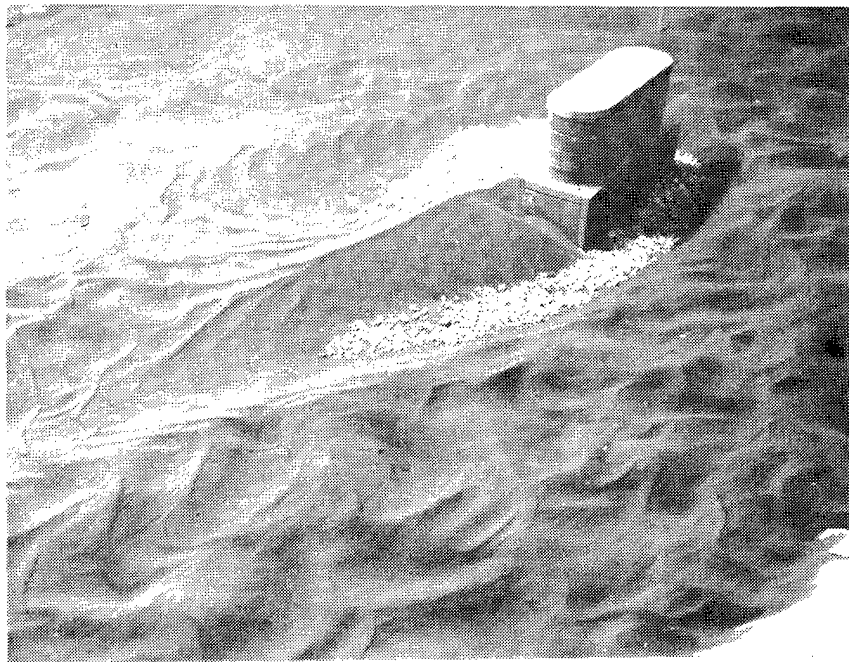

Photo 3. Run 13 looking upstream showing bed configuration at the end of run. Bed armor around pier placed at elevation 1.0 or 0.2 ft. below bed elevation. Note scour down to stone and bar downstream of pier.



Photo 4. Run 23 looking downstream showing bed configuration at end of run. Bed armor placed at elevation 1.1 or 0.1 ft. below bed level. Note large bar behind pier and exposed stone.

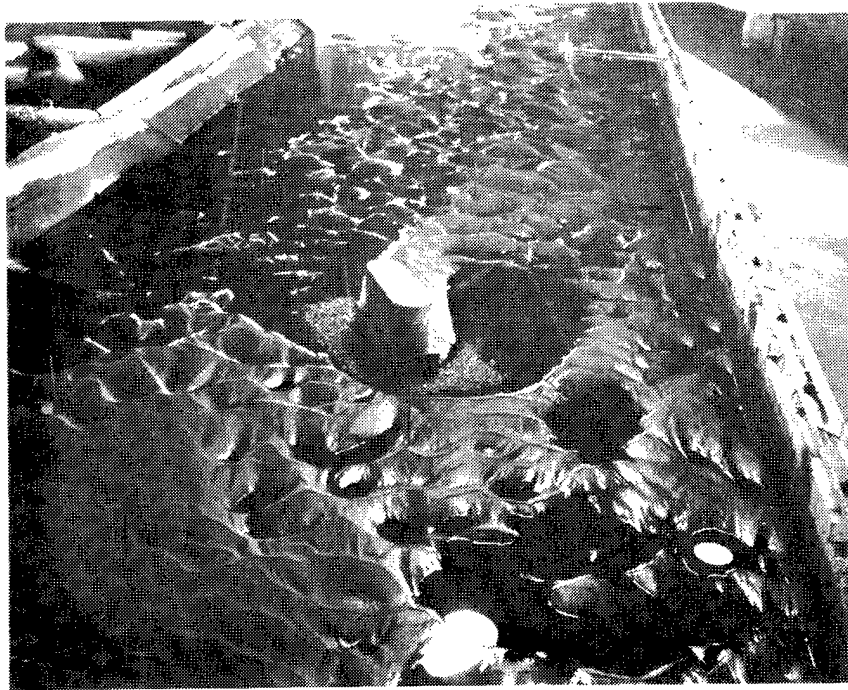

Photo 5. Run 25 looking downstream showing bed configuration at end of run. Bed armor placed at same elevation as Run 23 (Photo 4) but with velocity increased. Note deep scour on right with large bar behind pier. No failure of stone occurred.