

Laboratory Investigation of Missouri River Crossing Upstream of Bushwacker Bend

**MRD Hydraulic Laboratory Series
Report No. 16
October 1982**

**Mead Hydraulic Laboratory
Mead, Nebraska**

19990525 050



**US Army Corps
of Engineers**
Missouri River Division

**DISTRIBUTION STATEMENT A
Approved for Public Release
Distribution Unlimited**

REPORT DOCUMENTATION PAGE

Form Approved
OMB No. 0704-0188

Public reporting burden for this collection of information is estimated to average 1 hour per response, including the time for reviewing instructions, searching existing data sources, gathering and maintaining the data needed, and completing and reviewing the collection of information. Send comments regarding this burden estimate or any other aspect of this collection of information, including suggestions for reducing this burden, to Washington Headquarters Services, Directorate for Information Operations and Reports, 1215 Jefferson Davis Highway, Suite 1204, Arlington, VA 22202-4302, and to the Office of Management and Budget, Paperwork Reduction Project (0704-0188), Washington, DC 20503.

1. AGENCY USE ONLY (Leave blank) | 2. REPORT DATE
October 1982 | 3. REPORT TYPE AND DATES COVERED

4. TITLE AND SUBTITLE
Laboratory Investigation of Missouri River
Crossing Upstream of Bushwacker Bend | 5. FUNDING NUMBERS

6. AUTHOR(S)

7. PERFORMING ORGANIZATION NAME(S) AND ADDRESS(ES)
Mead Hydraulic Laboratory
Mead, NE | 8. PERFORMING ORGANIZATION
REPORT NUMBER

9. SPONSORING/MONITORING AGENCY NAME(S) AND ADDRESS(ES)
Omaha District, Corps of Engineers
215 N. 17th St.
Omaha, NE 68102 | 10. SPONSORING/MONITORING
AGENCY REPORT NUMBER
MRO Hydraulic
Laboratory Series
No. 96

11. SUPPLEMENTARY NOTES
U.S. Army Engineer District, Kansas City MO
Missouri River Division

12a. DISTRIBUTION/AVAILABILITY STATEMENT
The report has been approved for public
release and sale; its distribution is unlimited | 12b. DISTRIBUTION CODE

13. ABSTRACT (Maximum 200 words)
Presented in this report are the results of model studies of the channel
crossing between Grand River Bend at River mile (RM) 244 and Bushwacker
Bend at RM 248 on the Missouri River. The results of this study may
also be used to provide general guidance for the design of similar
channel crossings throughout the Missouri River Bank Stabilization and
Navigation Project.
The Bushwacker Bend area has been the site of numerous barge
groundings through the years. During 1980, a total of eight
groundings occurred in this crossing as a result of shifting or
meandering of the talweg.

14. SUBJECT TERMS
Bushwacker Bend
Channel crossings
talweg | 15. NUMBER OF PAGES
22 | 16. PRICE CODE

17. SECURITY CLASSIFICATION
OF REPORT
Unclassified | 18. SECURITY CLASSIFICATION
OF THIS PAGE
Unclassified | 19. SECURITY CLASSIFICATION
OF ABSTRACT
Unclassified | 20. LIMITATION OF ABSTRACT

DEPARTMENT OF THE ARMY

CORPS OF ENGINEERS

Laboratory Investigation of
Missouri River Crossing Upstream of
Bushwacker Bend

Conducted at
Mead Hydraulic Laboratory
Mead, Nebraska

U. S. Army Engineer District, Omaha
U. S. Army Engineer District, Kansas City
Missouri River Division, Omaha

TABLE OF CONTENTS

	<u>Page</u>
List of Photos	i
List of Plates	ii
List of Tables	iii
List of Publications	iv
<u>Chapter</u>	
I Introduction	1
II The Model	3
III Operating Procedures	4
IV Data Analysis	7
V Discussion on Tests	13
VI Conclusions	21
<u>Appendices</u>	
A References	
B Photos	
C Plates	
D Prototype Flow Distribution Data	

List of Photos

Photo Number

Caption

- 1 View of Model Dike Structures constructed of sheet metal with stone glued to surface to simulate prototype stone roughness.
- 2 View downstream from RM 247.7 toward crossing at RM 246.2, showing model construction methods. Dike structures at left abutted concrete block wall along convex bank. Sheet metal with stone attached was placed against block wall on right to form revetment.
- 3 View of one of the devices used to monitor water surface elevations in model. Flow will be from left to right. Structures in back are "L" heads in Bushwacker Bend.
- 4 View of model entrance, showing recirculation line at top of photo and tile drain drain pipe used to control flow distribution.
- 5 View upstream from about RM 245 during process of back-filling channel and bank areas with ground walnut shells.
- 6 View upstream at Bushwacker Bend Model during Run 56.
- 7 View of devices used to indicate depth in crossing on time lapse photos.
- 8 View of crossing through time lapse camera showing depths at depth indicators during Run 57 at hour 36.5.

List of Plates

<u>Plate Number</u>	<u>Title</u>
1	Location Map and 1980 Hydrographic Survey
2	Partial Model Layout with Bed Contours from Run 27
3	Discharge Rating and Discharge Frequency Curves for RM 246
4	Design Depth Exceedence Frequency Maps for Selected Tests
5	Flow Deviation Apportionments
6	Water Discharge vs. Suspended Sediment Discharge for Missouri River
7	Observed Depth at Grid Points 21 and 15 vs. Time for Run 43
8	Average Observed Depths vs. Design Depth Exceedence Frequencies During Run 43
9	Flow Distribution Imbalance Values and Discharge Ratios at Locations A Through F
10	Thalweg Crossing Locations Upstream from Crossing Structure
11	Average Navigation Depth at RM 245
12	Alignment Number 1 with Bed Contours from Run 46
13	Alignment Number 2 with Bed Contours from Run 51
14	Alignment Number 3 with Bed Contours from Run 57
15	Alignment Number 4 with Bed Contours from Run 60

List of Tables

<u>Table Number</u>	<u>Title</u>	<u>Page</u>
I	Model and Prototype Depths for Depth Indicators	5
II	Frequency Distributions From Depth Indicators, Run 43	10
III	Sediment Time-Scales	12
IV	Preliminary and Verification Run Data	15
V	Flow Distribution Data from Preliminary and Verification Runs	16

LIST OF PUBLICATIONS

MRD Hydraulic Laboratory Series Report No. 1, Operation and Function of the Mead Hydraulic Laboratory

MRD Hydraulic Laboratory Series Report No. 2, Laboratory Investigation of Underwater Sills on the Convex Bank of Pomeroy Bend

MRD Hydraulic Laboratory Series Report No. 3, Laboratory Investigation of Sioux City Boat Marina Entrance

MRD Hydraulic Laboratory Series Report No. 4, Laboratory Investigation of Manawa and Bellevue Bends

MRD Hydraulic Laboratory Series Report No. 5, Laboratory Investigation of Kansas River Bend and Kansas River Reach

MRD Hydraulic Laboratory Series Report No. 6, Laboratory Investigation of Junction Losses at the Kansas and Missouri River Confluence

MRD Hydraulic Laboratory Series Report No. 7, Laboratory Tests to Design Windrow Revetment for Bank Protection

MRD Hydraulic Laboratory Series Report No. 8, Preliminary Laboratory Investigation of Section 32 Hard Points

MRD Hydraulic Laboratory Series Report No. 9, Laboratory Investigation of Erosion Control using Hard Points

MRD Hydraulic Laboratory Series Report No. 10, Laboratory Investigation of Reinforced Revetment, Type I

MRD Hydraulic Laboratory Series Report No. 11, Laboratory Investigation of Vane Dike River Control Structures

MRD Hydraulic Laboratory Series Report No. 12, Laboratory Investigation of Reinforced Revetment, Types II, III, IV, and V

MRD Hydraulic Laboratory Series Report No. 13, Laboratory Investigation of Marina Entrances on the Missouri River

MRD Hydraulic Laboratory Series Report No. 14, Laboratory Investigation of Scour Around Bridge Piers

MRD Hydraulic Laboratory Series Report No. 15, Laboratory Investigation of Scour Downstream of Grade Control Sills on West Fork Ditch

LIST OF PUBLICATIONS
LIST OF PUBLICATIONS (Cont'd)

Also available for loan.

Condensed time lapse movies summarizing laboratory investigations, with narratives for:

Report No. 1
Report No. 7
Report No. 8
Report No. 9
Report No. 11

Complete time lapse movies of model tests with no narratives for:

Report No. 7
Report No. 8
Report No. 9
Report No. 10
Report No. 11
Report No. 12

I. INTRODUCTION

1. Presented in this report are the results of model studies of the channel crossing between Grand River Bend at River Mile (RM) 244 and Bushwacker Bend at RM 248 on the Missouri River. The results of this study may also be used to provide general guidance for the design of similar channel crossings throughout the Missouri River Bank Stabilization and Navigation Project. The model studies were conducted at the Mead Hydraulic Laboratory near Mead, Nebraska, by personnel of the Hydraulics Section of the Omaha District, Corps of Engineers, Messrs. Eugene Matson, William Howard, and Roy Singleton. The model study was reviewed and guidance provided by the Technical Engineering Branch of the Missouri River Division, Messrs. Alfred Harrison, Warren Mellema, and Albert Swoboda; the Kansas City District, Messrs. Walter Linder and Thomas Burke; and the Omaha District, Messrs. Howard Christian, Kenneth Murnan, and Frank Vovk. This report was prepared by Mr. Roy Singleton.
2. The Problem. The Corps of Engineers has the responsibility for maintaining a continuous navigation channel 9 feet deep and 300 feet wide for 734 miles on the Missouri River from its mouth at St. Louis, Missouri, to Sioux City, Iowa. As a result of the Corps' efforts, there have been an average of only 36 barge groundings per year since 1973. In recent years, the groundings which have occurred most frequently have been in the vicinity of channel crossings, particularly in crossings between long flat bends where the thalweg tends to shift upstream and downstream from the design crossing.
3. The Bushwacker Bend area, see plate 1, has been the site of numerous barge groundings through the years. During 1980, a total of eight groundings occurred in this crossing as a result of shifting or meandering of the thalweg. This meandering occurred during periods of constant discharge, predominantly around the design discharge of 46,000 cubic feet per second (cfs), and had no obvious time cycle. The shifting had been observed to occur within a relatively short period of time (less than 1 day). Even though this crossing is located only 3-1/2 miles downstream of the mouth of the Grand River, the meandering could not be correlated with changes in discharge from that stream.
4. Objective of Study. The objectives of the study were as follows:
 - a. Duplicate the shifting thalweg in a movable bed model.
 - b. Determine a method by which the position or location of the thalweg could be stabilized.
 - c. Provide general guidance for improving other channel crossings with similar problems.
5. Approach to Problem. A movable bed hydraulic model of the problem area was constructed. Flow distributions at six locations in the river and the model were compared to ensure similar approach and exit flow conditions between prototype and model. Graduated depth indicators were placed in a grid throughout the crossing between Grand River Bend and Bushwacker Bend.

The depth changes at these points in the crossing resulting from the downstream progression of the bed dunes were recorded on movie film through the use of time lapse photography. Viewing of the movie film aided in defining the location of the thalweg and in determining that the model crossing was behaving similar to the prototype crossing.

6. The following proposals were tested in the model to determine whether they would stabilize the thalweg through the crossing.

a. Reduce the channel width through the Grand River Bend from 700 to 550 feet by extending all upstream dike structures 150 feet further into the channel.

b. Locate additional dike structures upstream of the crossing between structures 257.9B and 258.0.

c. Make adjustments to the channel alignment upstream of the crossing.

d. Perform additional studies for combinations of the most promising of the above.

Certain of these proposals were tested at the prototype discharge of 35,000 cfs in addition to the prototype design discharge of 46,000 cfs.

II. THE MODEL

7. The section of river modeled was from RM 244 to RM 248. The crossing is located at RM 246.2. A 2-mile river reach downstream of the crossing was included to identify any adverse effects from changes to the crossing. Physical constraints limited the extent of the upstream river reach modeled. Physical constraints also dictated that the model be constructed to the mirror image of the river. See Plates 2, 4, 12, 13, 14, and 15.

8. Navigation flows in this reach of the river are normally between 46,000 and 80,000 cfs, with the average being about 58,000 cfs. See Plate 3. Crest elevations on the training structures are referenced to a construction reference plane, CRP, representative of the 46,000 cfs flow profile in this reach of the river. The differences between the structure crest elevation and the CRP elevation for some of the structures are noted on Plate 2 in the circles adjacent to the structures.

9. A continuous stone fill revetment protects the concave bankline through the Grand River Bend, while "L" head stone fill structures are used to protect the bankline through Bushwacker Bend. The crest elevation of the continuous revetment is 4 feet above the CRP elevation, while the crest of the "L" head structures is 2 feet above the CRP elevation. The crest elevation of the crossing control structure (256.75) between the bends is 3 feet above CRP. Dikes spaced at various increments normal to the flow are used along the convex alignment through both bends, constricting the channel width at these points to 700 feet. Certain portions of the dike structures are constructed below the CRP elevation, and would be overtopped during a 46,000 cfs flow. The riverward portion of the dike structure, if constructed below the CRP elevation, is called a sill. Landward of the sill, the dike structure is constructed above the CRP elevation. Several of the dikes in this study area contain only the sill portion. Structure 258.19 is an example. A modification to this is the vane dike which is angled to the flow. Two of these structures are located at the upper end of Bushwacker Bend (structures 256.24 and 256.44).

10. The model was constructed using distorted scales of 150:1 in the horizontal and 50:1 in the vertical. The 1980 hydrographic survey was used to lay out the model. Compare Plates 1 and 2. All structures were formed from sheet metal, with stone glued to the surface to simulate prototype stone roughness. See Photo 1. Provisions were made so that all structures could be easily modified both in the vertical and in the horizontal. Concrete blocks were set on the laboratory floor along the river alignment and the structures were then placed on or adjacent to the blocks. See Photo 2. The structure elevations were referenced to a model construction reference plane similar to that used on the Missouri River. Water surface monitoring devices were located on 10-foot centers throughout the model. See Photo 3. Sections of tile drain pipe were placed across the channel at the entrance to the model to aid in establishing the proper flow distribution. See Photo 4. The channel and bank areas were then backfilled with finely ground walnut shells to simulate the Missouri River bed material. See Photos 5 and 6.

III. OPERATING PROCEDURES*

11. Procedures During Preliminary and Verification Tests. Initial tests were made to establish the bed elevation with respect to the desired water surface elevation and depth of flow. A model gage elevation of 1.275 feet corresponded to the prototype gage elevation of 614.9 feet for a flow of 46,000 cfs at RM 246. See Plate 3. Control sections were established at four locations, labeled 1 to 4 on Plate 2, from which the average depth of flow in the model was calculated. The desired average depth of flow was maintained by adding to or extracting from the bed material in the system. The minimum duration of any single test was about 40 hours. This length of time was necessary to ensure that the model had stabilized.
12. After the desired depth had been achieved, the tile drain pipe at the entrance to the model and/or the velocity were adjusted through a series of tests to obtain a variety of thalweg crossing situations. Once the desired location of the crossing had been obtained, final adjustments were made to the model entrance and the velocity in efforts to produce the proper flow distributions throughout the model.
13. The flow distributions were determined from point velocity measurements taken across the channel at six different locations in the model, labeled A through F as shown on Plate 2. These flow distributions were compared to the flow distributions obtained from point velocity measurements taken at these same prototype locations during May 1981. See Appendix D. The method of analysis will be discussed later. Normally, three to six of the locations were monitored at least twice during each run. If a satisfactory agreement was not achieved between the model and prototype flow distributions, the model's entrance or the velocity was adjusted and the test repeated.
14. At the end of each run, cross section soundings were obtained in the model between RM 245 and RM 247.3. Model bed contour maps were prepared for comparison with the prototype bed contours. See Plate 2. Overhead photos were taken to aid in drawing the bed contours and to provide a permanent record of the test layout.
15. Monitoring the Meandering Thalweg. Since the problem with the meandering thalweg was transitory and of unknown cause, it was necessary to employ a monitoring method whereby the constantly changing depths throughout the crossing could be continually observed during the tests. The method employed involved placement of stationary depth indicators placed in a grid network throughout the crossing area. Depth variations at these locations resulting from bed material moving downstream in the form of dunes were recorded on 16 mm movie film through time lapse photography. It should be noted that the length and height of the model dunes may not exactly reproduce the length and height of the prototype dunes. There is some evidence that the height of the model dunes when converted to prototype dimensions would be slightly greater than the prototype dune height. This should have no effect on the model results if the average depth at each point is not affected.

*The reader should consult Reference 1 for a more detailed explanation of the operation of the Mead Hydraulic Laboratory.

16. The depth indicators were constructed of sheet metal with four tabs staggered at 0.06 foot intervals (3 feet prototype). See Photo 7. The depth indicators were placed across the channel as shown on Plate 4, Figure 9. Also see Photo 8. A total of 34 depth indicators were used during most of the test; however, this number was later reduced to 28 when additional structures were added to the convex alignment in the Grand River Bend. Because of their geometry and the large grid spacing, the depth indicators had little or no adverse effect on the bed locally nor did they influence the flow distribution downstream. The indicators were positioned such that the uppermost tab was 0.12 foot (6 feet prototype) below the water surface for the 46,000 cfs prototype discharge. Depths at these points could then be determined to within 0.06 foot (3 feet prototype). See Table I and Photo 8.

TABLE I
Model and Prototype Depths for Depth Indicators

<u>Number of Tabs Visible</u>	<u>Model Depth ft*</u>	<u>Prototype Depth ft*</u>
0	0 - 0.12	0 - 6
1	0.12 - 0.18	6 - 9
2	0.18 - 0.24	9 - 12
3	0.24 - 0.27	12 - 15
4	0.27+	15+

*Below CRP

17. Because these devices were at fixed increments with respect to the CRP and not the channel bed, it was important to maintain the average depth as nearly constant as possible. The average depth was determined from the control sections previously mentioned. If the average depth deviated more than 10 percent, material was either added to or extracted from the system.

18. Two factors were found to affect the average depth: Attrition of bed material and temperature. Loss of bed material from attrition generally occurs over several months as a result of the repeated draining of the model at the end of each run, and may be controlled by observing the average depth and adding material as needed. The second factor affecting the average depth, and the most troublesome, was the temperature. As the ambient air temperature in the laboratory changed with the seasons, the temperature of the water in the model also changed. Water temperatures below 70 degrees caused no problems; however, water temperatures greater than 70 degrees caused the bed to swell. This problem was controlled by using a device which monitored the water temperatures. Once the water in the model reached a certain temperature, cold water was slowly introduced into the system while the warm water was simultaneously drained from the system.

19. Procedures During Tests to Control the Meandering Thalweg. All of the operating procedures discussed previously were also employed during these tests. However, because of the structural changes which were made, some of the procedures were modified. As mentioned earlier, six of the depth indicators were removed from the left side of the model when structures were

added in this area. The indicators also had to be completely relocated for two of the realignment schemes. In these two runs, the relocated crossing control structure was used as the reference point for locating row seven of the depth indicators. The other rows were then located upstream from row seven, as shown on Plate 4, Figure 9.

20. Since the objective of these tests was to redistribute the flow at the crossing structure location, the flow distributions at the upper three locations (A, B, and C) were not expected to conform to the prototype flow. However, it was essential that the flow distributions in the lower three locations (D, E, and F) still conform to the prototype flow. See Plate 9. Any deviation from the desired flow distribution in the lower three locations could mean that the upstream changes had produced adverse effects in the downstream area, or that the model was out of verification. Because of this last possibility, verification runs were repeated during these tests.

IV. DATA ANALYSIS

21. The following were used to analyze the test results:

- a. The flow distribution throughout the model.
- b. The bed contour maps from depth soundings along with the overhead photos.
- c. The frequency distributions from the depth indicators.

22. Flow Distribution. The flow distributions in the prototype and model were compared at six locations, A through F. See Plate 2. This was accomplished by obtaining point velocities, v_j , and depths, d_j , along each of the cross sections at locations A through F in the model, where similar measurements were obtained at the same prototype locations. Incremental discharges,

$$\Delta Q_i = \left(\frac{v_j + v_{j+1}}{2} \right) \left(\frac{d_j + d_{j+1}}{2} \right) \Delta w_i \quad (1)$$

were computed for each channel segment, Δw_i , in the channel cross section. At each location, the discharge based on all the measured points was then determined by summing the incremental discharges,

$$Q' = \sum \Delta Q_i \quad (2)$$

23. The ratios of the incremental discharges to the sum of the incremental discharge were then computed for each location,

$$\text{ratio} = \frac{\Delta Q_1}{Q'}, \frac{\Delta Q_2}{Q'}, \dots \quad (3)$$

These ratios represented portions of the measured discharge flowing through each segment of the cross section. Since these ratios are nondimensional and represent specific segments of the cross section they may be compared to their counterpart ratios from the prototype. The difference between the model ratio and the prototype ratio for the same cross section segment, expressed as a percentage, represents the percent deviation in the flow distribution between model and prototype in that segment.

$$\delta_i = \left(\left[\frac{\Delta Q_i}{Q'} \right]_m - \left[\frac{\Delta Q_i}{Q'} \right]_p \right) \times 100\% \quad (4)$$

24. A plot of the deviation values with respect to the channel segments they represent produces a graph of the apportionment of the flow deviation across the channel. There are five types of deviation apportionments possible. They may be generalized into three forms: A two part, a three part, and a

multi-part apportionment as noted on Plate 5. The two part apportionment may either be (+ -) or (- +) and the three part may be either (+ - +) or (- + -). The magnitude of an individual deviation is relative and depends not only on the difference between the model and prototype flow conditions, but also on the number of channel segments in the cross section. The flow distribution imbalance between the model and prototype is obtained by summing either the positive or negative deviations. Since the sum of the deviations will always be zero, the flow distribution imbalance may also be obtained from the following.

$$\Delta = \frac{\sum |\delta_i|}{2} \quad (5)$$

25. For these model tests, a flow distribution imbalance of 15 percent was defined as acceptable. If the imbalance exceeded 15 percent, then the flow distribution in the model at that location was assumed to be different from the prototype. Table V lists the Δ values, and type apportionments for the preliminary and verification runs. Plate 9, Figure 1, illustrates the Δ values for the test runs. In the tabulation of the apportionment types, the first sign indicates the deviation adjacent to the concave alignment, and the second sign indicates the deviation adjacent to the convex alignment. A (+ -) would indicate a two-part apportionment with a greater flow in the model than in the prototype against the convex alignment. A (- -) would indicate a three-part flow with a deficiency in the model flow at both the concave and convex alignments. The middle sign on the three-part flow has been omitted for simplicity in the table. A (+ N) would indicate a multipart apportionment with a greater flow in the model against the concave alignment. An N part apportionment would generally imply good agreement between prototype and model, since the deviations are not grouped. Compare Figures 1, 2, and 3 on Plate 5.

26. In conjunction with the δ calculations, a comparison may be made between the sum of the incremental discharges, Q' , and the total discharge, Q , (determined by other means). Since the flow distribution measurements did not include the flows at either edge of the channel, the values of Q'/Q will be less than unity. See Appendix D. Because Q'/Q is a dimensionless quantity a comparison may be made between the model and the prototype values.

$$\text{Where } \lambda = \frac{(Q'/Q)_m}{(Q'/Q)_p} \quad (6)$$

If this ratio is greater or less than unity, the model flow is relatively greater or less than the prototype flow through the measured portion of the channel. A comparison of these λ values from run to run will then show the influence of structural changes on the unmeasured flow zone. Table V lists the λ values for the preliminary and verification run, while Plate 9, Figure 2, illustrates these values for the test runs. In plotting the data on Plate 9, the data are presented for each location, and the different runs were grouped by type of test. This was done to illustrate the range of the data within tests of the same type and to allow visual comparison of data from one test to another and from one model location to another. The dashed

lines on Plate 9, Figure 1, represent the maximum acceptable flow distribution imbalance of 15 percent. The pair of dashed lines on Plate 9, Figure 2, represent the range in the base run data at that location. Test data outside of this range would indicate the influence of the test changes on the flow at that location.

27. Bed Contour Map. At the end of each test, sonar soundings were obtained between RM 245 and RM 247.3 in the model. In general, about nine soundings were taken across the channel at roughly 2-1/2-foot intervals through the crossing and about eight soundings were obtained outside of the crossing at intervals of 5 to 10 feet. These soundings were then used to produce contour maps of the crossing area and the channel. The contour maps were used in verifying the model and in monitoring the effects of the tests on the channel. See Plates 2, 12, 13, 14, and 15. Contour maps of all the runs are not included in this report. Plate 10 summarizes the locations of the thalweg crossing in the various tests. The location of the thalweg crossing was measured from the downstream end of the crossing structure to the point at which the thalweg broke away from the concave bankline. Plate 11 summarizes the average navigation depth for the most downstream cross section at RM 245.

28. Frequency Distributions from Depth Indicators. During all tests, time lapse photos of the grid network in the crossing were taken to record the changing depths through the number of tabs visible at each of the depth indicators. See Photo 8. Later, segments of these movies (covering a specific sample period) were viewed and from each selected photo a list was made of the number of visible tabs at each point in the grid. See Table II and Plate 7. Frequency distributions were then compiled for each point in the grid. The frequency distributions were used to construct frequency maps of the crossing in which each isogram on the map indicated the percent of time the depth along that isogram was less than 0.18 foot (9 feet in prototype). See Plate 4, Figures 1-8. In this way, a line representing the predominant location of the thalweg through the crossing could be sketched on the map and a judgment made on the quality of the crossing. As mentioned previously, the model dune geometry may not exactly duplicate that of the prototype. If this is true then the model frequency distribution would not apply to the prototype. However this affect would be relative in that only the magnitudes of the isograms on the frequency maps would change. The general shape of the frequency maps would not change.

TABLE II

Frequency Distributions from Depth Indicators

Run 43

Tab Interval	Row 1		Row 2		Row 3		Row 4		Row 5		Row 6		Row 7	
	Freq.	Cum. Freq. %	Freq.	Cum. Freq. %	Freq.	Cum. Freq. %	Freq.	Cum. Freq. %	Freq.	Cum. Freq. %	Freq.	Cum. Freq. %	Freq.	Cum. Freq. %
Column 1														
0-1	0	0	0	0	1	1	2	1	0	0	0	0	0	0
1-2	30	19*	58	36*	56	36*	63	41*	70	44*	13	8*	4	4
2-3	115	91	78	85	63	75	81	91	70	88	83	60	61	4
3-4	9	96	24	100	40	100	14	100	18	99	53	93	82	9
4+	6	100	0	100	0	100	0	100	2	100	11	100	13	100
Mean Depth ₂	10.3		9.8		10.1		9.6		9.4		11.4		12.5	
Column 2														
0-1	0	0	0	0	2	1	0	0	9	6	0	0	0	0
1-2	18	11*	9	6*	27	18*	34	21*	44	33*	21	13*	21	13*
2-3	111	81	62	44	54	52	74	68	93	91	105	79	67	51
3-4	25	96	74	91	74	98	49	98	14	100	34	100	70	91
4+	6	100	15	100	3	100	3	100	0	100	0	100	2	100
Mean Depth	10.7		12.4		11.8		10.9		9.9		10.7		11.6	
Column 3														
0-1	3	2	0	0	0	0	0	0	0	0	1	1	0	0
1-2	34	23*	36	22*	13	8*	37	23*	6	4*	15	10*	0	0
2-3	76	71	86	76	84	61	100	86	115	76	66	51	42	26
3-4	44	98	37	99	50	92	23	100	38	99	56	86	96	81
4+	3	100	1	100	13	100	0	100	1	100	22	100	22	100
Mean Depth	10.7		10.5		11.4		10.3		10.9		11.9		13.2	

1/ Number of times depth of flow at depth indicator within specific tab interval.

2/ Mean tab interval converted to prototype flow depth in feet, see Table I.

*Percent of time depth was less than design depth.

$t_r = 0.15 (60) = 9$, see Tables III and IV

$t_m = 48 \div 9 = 5.3$ hrs, see Equation 8

Sample period between operating hours 34.9 and 40.3 = 5.4 hrs.

Time increment between readings = $5.4 \div (160-1) = 0.034$ hr. = 2 min., see plate 7.

29. Sample Period. For the frequency distributions to be valid it was important that the sample period from test to test be similar. Since this meandering thalweg problem is a sediment transport problem, the sample periods in the different model tests had to cover periods of equal sediment transport and not equal periods of time. This is significant since the sediment transport in the model varied as a result of changes in depth, velocity, and water temperature. See Table IV. It is also important in that two different prototype discharges were used and, therefore, two different prototype sediment discharges had to be considered.

30. The time ratio for sediment transport is as follows:

$$t_r = \frac{T_p}{T_m} = \frac{L_r^2 h_r G_r}{(Q_t)_r} \quad (7)$$

where: T = time (Sample period)

p & m = subscripts, indicate prototype or model values

L_r = length ratio = 150

h_r = height ratio = 50

G_r = specific gravity ratio of bed material
= 2, ($G_p = 2.6$, $G_m = 1.3$)

$(Q_t)_r = \frac{(Q_t)_p}{(Q_t)_m}$ = Total sediment load ratio (variable)

31. The total sediment load for the model conditions was available from each run (see Table IV); however, the prototype values were estimated from the annual discharges of water and suspended loads for the years 1955 through 1974 at the gaging stations in Kansas City and Herman, Missouri. 3/4/5/ These data were reduced to average daily discharges for each year and plotted. See Plate 6. A best fit line was then determined for both gaging stations. The Bushwacker Bend area is halfway between these two gages so a line midway between the two was constructed to represent the Bushwacker Bend area. The total sediment load was then estimated to be 10 percent greater than the suspended load. Table III lists the sediment time ratios for the different discharges.

TABLE III
Sediment Time Scales

Prototype Discharge		Sediment Time Scale
Water cfs	Sediment T P D	
46,000	185,000	$t_r = 0.15 (Q_t)_m$
35,000	138,000	$t_r = 0.20 (Q_t)_m$

Note: $(Q_t)_m$ in lbs/hr

32. Many considerations were involved in the determination of the length of the required sample period. What would be a significant time equivalent sample period for the prototype? In the model, if the sample period was too short, the shifting of the thalweg might not be observed; or if the sampling period was too long, more data than necessary would be obtained, resulting in extra work. The length of the sample period would obviously also affect the number of observations necessary to define the frequency distribution for the depths at each grid point.

33. Considering that the shifting of the thalweg in the prototype had occurred in a period as short as one day, it was decided that a 48-hour prototype time period would be used as a standard. Then the length of the sample period in the model would be:

$$T_m = 48 \div t_r \quad (8)$$

After examining the data from several runs it was found that subdividing the sample period into 159 increments (160 observations) gave sufficient data upon which to establish the frequency distributions. This would be equivalent to taking depth measurements in the prototype about every 18 minutes for 48 hours.

34. With respect to the total length of time of each test, the sample period, T_m , in the time lapse photos, was always measured back in time from the end of each test. The film was subdivided into 159 semi-equal time periods, and the tab readings at these times were then listed. Because of the large volume of data and the predominant location of the thalweg, only Columns 1, 2, and 3 of the depth indicators were listed. See Table II and Plate 4. Data from Columns 4 and 5 may easily be obtained from the time lapse photos if the need occurs.

V. DISCUSSION ON TESTS

35. Preliminary and Verification Tests. Verification of the prototype condition was complicated by the fact that the shifting of the channel thalweg was not fully understood, and prototype data seemed to refute the existence of a problem. Eight groundings had been reported at this location during 1980, one in September and seven in October, but the hydrographic survey data collected in this area on 21 and 22 September did not indicate any problem with the crossing location. See Plate 1. In fact, the depths ranged from 9 to 12 feet through the crossing. The depths associated with the flow distribution measurements for RM 246.4, location C, showed an average depth of 12 feet. See Appendix D. Despite these incongruities, it was believed that the instability of the thalweg could be associated with a unique combination of depth and velocity.
36. During the first series of tests, a variety of depths and velocities were used in an attempt to determine this combination. This procedure had been used in previous model studies to establish flow regimes for meandering and nonmeandering conditions in long flat bends. See Reference 2. It was believed that similar flow regimes could be established for the crossing in this model with the desired condition being between the two flow regimes. During the tests, the flow distributions for the three upstream channel locations were monitored (locations A, B, and C, see Plate 2). Adjustments were made to the model entrance to cause the flow distribution at location A to be similar between prototype and model. Tables IV and V list the results of these tests along with the results of subsequent verification check runs. Also compare Plates 1 and 2. The initial apportionment of the flow distribution sought for the nonmeandering flow regime was the (+ -) condition. This would result when the flow in the model adjacent to the concave bankline was greater than the flow in the prototype. However, it was discovered that in almost every case the flow had a tendency to break away from the concave bankline upstream of the crossing structure.
37. In run 13, the desired condition was produced at "C" and possibly at "B," but the flow distribution at "A" was opposite of the desired condition. See Table V. Runs 17 and 19 appeared to approach the desired condition but soundings and overhead photos showed that the thalweg tended to be located at the centerline of the channel. At first it was believed that the main component of the flow at "A" was too acutely angled toward the downstream concave bankline and was subsequently being reflected toward the convex bankline. Adjustments were made to the model entrance, and later the velocity was lowered. Neither attempt to induce the thalweg to follow the concave bankline was successful.
38. These preliminary runs were considered to be dissimilar to the prototype condition because no large bar or shoal area was observed in the crossing. However, upon reviewing the time lapse movies, it became obvious that for random periods of time the grid points near the crossing structure indicated depths which were considerably less than 9 feet. Frequency distributions were then compiled from the depth indicator data. Special frequency maps were constructed of the crossing in which each isogram on the map indicated the percent of time the depth along the isogram was less than the design depth. All of the frequency maps were similar in that they showed a region

(the predominant thalweg) upstream of the crossing structure which was 9 feet or greater most of the time. It should be noted that even though the grid points downstream from this region were more frequently less than 9 feet, the average depth at each point was still greater than 9 feet. See Table II.

39. Plate 4, Figure 1, shows a composite frequency map constructed using data from runs 24, 25, 27, 28, and verification check runs 39, 42, and 43. This map shows that the depth along the path of the arrows (the thalweg) was 9 feet or greater 90 percent of the time, but along the concave alignment there is a spot at which the depth was 9 feet or greater only 75 percent of the time. Even though chances are better that depths will be greater than 9 feet along the arrow path, these occurrences are random and depths less than 9 feet may occur along this path at the same time as depths greater or less than 9 feet occur along the concave alignment. See Plate 7. This would explain why the thalweg appears to be shifting from spot to spot.

40. A region may be identified as the location of the predominant thalweg, but in actuality the average depths in the crossing are such that dune heights cause depths less than that desired to occur. It should also be noted that the probability of a specific location having a depth less than a certain value depends upon the average depth at that location. For example, if the average depth at a point is 9 feet, then 50 percent of the time that point will have depths of less than 9 feet. But, if the average depth is 12 feet, then there may be only a 10 percent chance that a depth of less than 9 feet will occur at that point. See Plate 8.

41. It is also possible that this "meandering" of the thalweg occurs at higher discharges but because of the greater average depth it is not noticed. This model was not verified for a higher discharge but the gage settings for runs 17 and 19 correspond to a prototype gage elevation for a 60,000 cfs flow and, as mentioned above, the bed contours and frequency maps from these runs indicate that the predominant thalweg was not against the concave bankline through the crossing.

42. It was attempted to maintain an average velocity of 0.45 fps for the first series of tests, runs 29 through 37. However, the sediment transport on several of these runs dropped so low that the required sample period of the depth indicators became as great or greater than the length of the test. The model was then reverified for a velocity of 0.52 fps and the remaining tests conducted at this higher velocity.

43. In the verification tests, (27, 38, 43, and 58), the flow distribution imbalance at locations A, B, E, and F was less than 15 percent and, therefore, considered acceptable. See Table V, and Plate 9, Figure 1. The flow distribution imbalance at locations C and D, located near the crossing, tended to be greater than the acceptable value. Since the approach and exit locations were acceptable, the excessive flow distribution imbalance at C and D was accepted and attributed to the fact that the crossing was supposed to be unstable.

44. The discharge ratio, λ , tended to be equal to or greater than unity at all locations except at the lower location F, which was generally less than

TABLE IV
PRELIMINARY AND VERIFICATION RUN DATA

RUN NO.	AVG. VELOCITY fps	AVG. DEPTH ft.	GAGE ELEV. ft.	SLOPE OF W.S. (10 ⁻⁴)	WATER TEMP. F°	SEDIMENT DISCHARGE lb/hr.
10	0.58	0.26	1.28	7.4	59	-
11	0.58	0.27	1.29	7.1	59	-
12	0.51	0.26	1.29	7.1	62	-
13	0.51	0.26	1.29	7.0	68	-
14	0.54	0.25	1.30	7.2	67	-
15	0.58	0.23	1.30	7.4	71	-
16	0.54	0.24	1.29	7.2	71	-
17	0.50	0.27	1.32	7.0	69	104
18	0.53	0.25	1.29	7.1	67	158
19	0.46	0.26	1.32	6.5	68	105
20	0.61	0.20	1.28	7.5	74	164
21	0.50	0.21	1.29	8.2	73	115
22	0.58	0.19	1.28	8.4	75	219
23	0.50	0.22	1.28	6.9	77	97
24	0.44	0.24	1.28	7.2	63	87
25	0.46	0.23	1.28	7.3	62	49
26	Flow into Convex Bank at River Mile 246.7 - No Data Taken					52
*27	0.43	0.25	1.28	6.6	62	34
28	0.44	0.24	1.28	6.5	65	43
*38	0.47	0.24	1.29	7.0	64	32
39	0.54	0.20	1.29	8.4	67	75
40	Void - Model Controls Failed				67	-
41	Void - Adjusting Model				66	28
42	0.53	0.22	1.29	8.2	67	59
*43	0.52	0.23	1.29	8.0	69	60
*58	0.54	0.24	1.28	8.8	58	87

*Base Verification Runs

TABLE V
FLOW DISTRIBUTION DATA FROM
PRELIMINARY AND VERIFICATION RUNS

RUN NO.	FLOW APPORTIONMENT AND DISTRIBUTION IMBALANCE AT LOCATIONS						DISCHARGE RATIOS AT LOCATIONS					
	A	B	C	D	E	F	A	B	C	D	E	F
10	(-+)10	(+)-8	(-+)4	-	-	-	1.13	0.91	0.97	-	-	-
11	(-+)11	(+N)8	(++)6	-	-	-	0.77	1.04	1.18	-	-	-
12	(-+)9	(++)10	(++)13	-	-	-	1.07	1.20	1.14	-	-	-
13	(-+)5	(+N)5	(-+)16	(-+)7	(+)-4	(-N)8	1.07	1.03	1.52	1.12	1.18	1.16
14	(-+)4	(-+)17	(-)-6	(-+)4	(++)2	(++)16	1.07	1.01	1.18	1.05	1.40	0.95
15	(-+)8	(-+)14	(-+)9	(-+)6	(+)-5	(-+)12	1.21	1.09	1.25	0.84	1.25	0.96
16	(-+)4	(+N)5	(-+)9	(-+)6	(-)-4	(++)15	1.20	1.02	1.31	1.14	1.35	1.06
17	(+N)7	(++)12	(+)-2	(-N)5	(+)-3	(++)9	1.14	1.15	1.38	1.15	1.33	1.03
18	(-)-13	(++)16	(-N)9	(-+)7	(+)-8	(-+)15	1.34	1.12	1.42	1.08	1.13	1.18
19	(+N)7	(-+)12	(+)-8	(-+)3	(+)-13	(-+)28	1.30	1.06	1.61	1.20	1.05	1.51
20	(-+)17	(-+)14	(-)-8	(-+)7	(++)13	(-+)24	1.11	1.02	1.50	0.96	1.01	1.21
21	(+N)10	(++)8	(-)-5	(-+)8	(+)-24	(-+)20	1.18	1.27	1.10	1.22	0.95	1.17
22	(++)10	(+)-9	(-)-12	-	-	-	1.27	1.09	1.32	-	-	-
23	(+N)7	(+)-3	(+N)6	-	-	-	1.32	1.38	1.28	-	-	-
24	(-+)8	(+)-6	(-+)12	(-+)20	(+)-7	(++)10	1.19	1.31	1.35	1.00	1.18	0.97
25	(-+)8	(-+)23	(-N)7	(-+)18	(++)10	(++)21	1.55	1.24	1.23	1.00	1.22	0.99
26	-	-	-	-	-	-	-	-	-	-	-	-
*27	(-+)4	(-+)10	(-+)16	(-+)21	(+)-4	(-N)8	1.16	1.15	1.16	1.14	1.13	1.03
28	(+N)8	(-+)7	(-+)18	(-+)12	(++)6	(++)7	1.24	1.27	1.30	1.28	1.20	0.87
*38	(-+)10	(++)8	(-+)18	(-+)18	(+N)4	(-+)10	1.12	1.01	1.23	1.10	1.24	1.16
39	(+N)6	(-+)26	(-+)14	(-+)24	(++)7	(++)12	1.12	0.93	1.36	0.98	1.16	0.77
40	-	-	-	-	-	-	-	-	-	-	-	-
41	(-+)8	(++)12	(-+)30	(++)9	(+)-4	(-+)12	1.25	0.92	1.30	0.90	1.26	0.88
42	(-+)10	(+)-8	(-+)8	(-+)14	(+)-8	(-+)18	1.16	1.00	1.32	1.12	1.18	0.97
*43	(+N)10	(-+)13	(++)8	(-+)14	(+)-4	(-+)7	1.28	1.02	1.18	1.10	1.30	0.86
*58	(+N)12	(-+)12	(-+)11	(-+)13	(+)-10	(+N)6	1.24	0.99	1.24	0.85	1.20	0.90

*Base Verification Runs

unity. See Table V and Plate 9, Figure 2. The ratios greater than unity could be attributed to insufficient flows over the sills in the model. The sill elevations had been lowered during preliminary tests but caused an excess of flow along the convex side at the crossing. Because of the minor discrepancy in flow distributions and the complexity involved in finding correct sill elevations on five structures, no additional attempts were made to adjust the sill elevations. At location F, the measured model flows were less than the prototype flows for runs 38, 43, and 58. This was caused by flows in the model flanking the vane dike structures on the convex side. It is possible that the openings between the "L" head structures exhibited a greater roughness in the model than in the prototype, thereby causing the flow to move toward the convex side. Based on results from verification run 27, the discrepancies noticed in runs 38 and 43 did not appear to be significant and at that point it did not seem wise to make any further adjustment to the model. However, in some of the tests discussed in the next section, the flow tended to break away from the concave bank at about RM 245.2 causing a shoal to develop at RM 245 which is not typical of the prototype. In run 58, more detailed soundings in the vicinity of RM 245 also showed the same condition. Therefore, the less than desired average depths at RM 245, reported in the next sections, should be viewed with some skepticism. For comparative purposes, the average depth in the navigation portion of the channel (2 feet in model, 300 feet in prototype) at RM 245 was computed for the various tests. These values are plotted on Plate 11.

45. Tests to Control the Meandering Thalweg. The following proposals were tested to determine whether the thalweg through the crossing would be stabilized by forcing the flow to follow the concave alignment.

a. Reduce the unrestricted channel width upstream of the crossing from 700 feet to 550 feet by extending all upstream dike structures 150 feet further into the channel.

b. Locate additional dike structures between structures 257.9B and 258.0.

c. Raise existing sills above water surface.

d. Adjust the channel alignment upstream of the crossing.

e. Combinations of the above.

46. Tests With Reduced Channel Width. Runs 29, 30, 40, and 45 were made with the sills of the five dike structures upstream of river mile 246.2 extended into the channel a distance of 150 feet (1 foot in model). This reduced the unrestricted channel width from 700 feet to 550 feet (4.67 feet to 3.67 feet in model). This reduced width was the minimum width to which the channel could be narrowed without interfering with navigation. If these tests proved successful, shorter sill extensions were to be tested. Runs 40 and 45 were repeat tests of run 29 but at the higher average velocity of 0.52 fps. Run 30 was a low flow test with a stage elevation equivalent to a 35,000 cfs discharge.

47. The flow distributions and discharge ratios at locations A, B, and C were affected. See Plate 9. The flow distributions, discharge ratios, and average depths below the crossing did not appear to be adversely affected. See Plates 9, and 11. However, no improvement in the crossing was noticed. See Plates 10 and 4, Figure 2. The results of the low flow test, run 30, exhibited similar results. However, the bed contours in run 30 indicated a possible meander between RM 247.2 and the crossing structure. This would seem to agree with the concept of the thalweg crossing location as a function of depth, with the crossing moving upstream as the depth decreases.

48. Tests With An Additional Dike. Runs 31, 32, 44, and 50 were conducted with an additional dike. In runs 31, 32, and 44 the additional dike was located halfway between dike structures 257.9B and 258. In run 50, the additional dike was located at the one-third point upstream from structure 257.9B. The sill crest elevation of the additional dike was 1 foot below CRP in both cases. Run 32 was a low flow (35,000 cfs) test, and run 44 was a repeat of run 31 but at the higher average velocity of 0.52 fps. The purpose of these tests was an attempt to discourage the tendency of the flow to accumulate along the convex bank downstream from structure 258.0. No appreciable change from the base conditions was noticed in the crossing or in the monitored parameters. See Plates 9, 10, 11, and 4, Figure 3.

49. Tests With Sills Raised Above CRP. In run 47, the sills of the five dike structures upstream of river mile 246.2 were raised above the 46,000 cfs flow line (CRP). If these tests proved successful, runs with lower sill elevations were to be tested. However, no appreciable differences were observed as a result of these changes. See Plates 9, 10, and 11.

50. Combinations of Above Tests. In run 48, dikes were placed at the one-third and two-thirds locations between structures 257.9B and 258.0. The sills of these new structures were raised above CRP, as were the sills on the other five dike structures. The discharge ratios at locations A, B, C, and D were affected but the crossing condition was not improved. See Plates 9, 10, 11, and 4, Figure 4.

51. In run 49, the structure configurations were the same as run 48 except that the openings between each of the dike structures upstream of the crossing were partially closed forming "L" head type structures. The results of test 49 were similar to those of test 48. See Plates 9, 10, 11, and 4, Figure 4.

52. Tests With Alignment Changes. In these tests, the crossing structure 256.75 was relocated, necessitating realignment of a portion of the upstream concave revetment as well as modifications to some structures along the convex alignment. The crossing structure was relocated at four different sites, identified as alignment 1, 2, 3, or 4.

53. Tests With Crossing Structure on Alignment 1. In these tests, (runs 34, 35, 36, 37, and 46) the crossing structure was simply moved riverward a distance of 100 feet. The upstream concave alignment for a distance of 3,150 feet was adjusted to accommodate the new location of the crossing structure. See Plate 12. No other structural changes were made. Test 46 was a repeat run of tests 34, 35, and 37 but at the higher average velocity of 0.52 fps. Run 36 was a low flow test for 35,000 cfs. These tests were

generally very similar to the base conditions. See Plates 9, 10, 11, 12, and 4, Figure 5. The low flow test again indicated meandering between RM 247.2 and RM 246.8.

54. Tests With Crossing Structure on Alignment 2. In these tests (runs 51, 52, 53, 55, and 56) the crossing structure was moved upstream to RM 246.7 and offset 275 feet riverward from the existing alignment. The upstream concave alignment was adjusted for a distance of 2,700 feet. Structures 258.0 and 257.9B were shortened so that the channel width would be 700 feet. An additional structure was placed halfway between structures 258.0 and 257.9B. The openings between these three structures were partially closed forming "L" heads. See Plate 13. Run 53 was a low flow test representative of the 35,000 cfs flow. Run 55 was a repeat of run 51 for demonstration purposes and the only data obtained was from the time lapse movies.

55. Runs 51, 52, 55, and 56 produced good results. See Plate 4, Figure 6. However, in run 51, shoaling developed between RM 245.3 and RM 245, producing an average navigation depth of only 6 feet along the concave alignment. See Plate 11. In runs 52 and 56, an attempt was made to isolate the cause of the shoaling. In run 52, the openings between all the "L" head structures except for the one downstream of structure 258.0 were closed. A channel block was also placed between the upstream end of vane dike 256.44 and the model basin wall, preventing flow landward of this structure. The crossing in this test was also very good, and the average navigation depth along the concave alignment at RM 245 increased to 9.5 feet, see Plate 11; however, the bed contours indicated a slight tendency for the meander to persist. In run 56 only two "L" head structures were closed, the one downstream and the one upstream of 257.9B. However, additional structures were placed along the convex alignment downstream of the crossing. Dike structures with crest elevations above CRP were placed at river miles 245.15, 245.45, and 245.9. Channel blocks were placed at the upstream ends of both vane dikes, and the vane dikes were raised above CRP. This arrangement also produced a good crossing and the average depth at RM 245 increased to 12.5 feet, see Plate 11; but, shoaling was still observed at RM 245.3 where the average navigation depth was 9 feet. The improved condition at RM 245 resulted from the new structures along the convex bank deflecting the flow back across the channel, thereby reducing the shoal effects at this location. From these two runs it may be concluded that eliminating the roughness elements caused by the openings between the "L" head structures in the model improved the downstream channel depths. However, since the shoaling condition could neither be eliminated nor attributed entirely to model conditions, the crossing structure was moved to a third location.

56. Tests With Crossing Structure on Alignment 3. In these tests (runs 57 and 59), the crossing structure was located 1,200 feet downstream from location 2 at RM 246.5. The crossing structure was offset riverward from the existing alignment 150 feet. The upstream concave alignment was adjusted for a distance of 2,700 feet to accommodate the crossing structure. See Plate 14.

57. In run 57, structure 258.0 was shortened to provide a channel width of 700 feet. An additional dike was located halfway between structures 258.0 and 257.9B at RM 246.7. The openings between these two structures were

partially closed, forming "L" heads at these points. The results of this test were similar to the results of tests at Alignment 1. The crossing was again upstream of the crossing structure. See Plate 4, Figure 7. A shoal also developed at RM 245, with an average navigation depth of 5.5 feet. See Plate 11.

58. At this point, a verification test, run 58, was repeated to determine if model conditions had changed. The verification test results were similar to the other verification tests. This time, however, more detailed soundings were obtained in the vicinity of RM 245. The bed contours from these soundings also showed a tendency for the flow to break away from the concave alignment around RM 245.2.

59. Testing continued with run 59. This run was essentially a repeat of run 57 except that the "L" head was removed from the structure at RM 246.7. The thalweg was again upstream of the crossing structure; however, the average depth at RM 245 had increased to 10 feet. See Plate 11. The bed contours again indicated a slight meander around RM 245.2.

60. Tests with Crossing Structure on Alignment 4. In runs 60 and 61, the crossing structure was offset from Alignment 3 an additional 125 feet riverward, making the total offset 275 feet. Structure 258.9B was shortened to provide a channel width of 700 feet. An additional dike structure was placed at RM 246.38.

61. The results of test 60 were good. See Plates 9, 10, 11, 15, and 4, Figure 8. The thalweg followed the concave alignment through the crossing. The average navigation depth at RM 245 was 9 feet. The bed contours in the vicinity of RM 245 were similar to the last verification test, run 58.

62. Run 61 was similar to run 60 except that the opening downstream of the dike at RM 246.38 was closed. Scour depths in the vicinity of this structure during run 60 were in excess of 21 feet. By closing the opening, it was hoped that the scour would be less and that this might also improve the flow conditions at RM 245. The overall results of this test were similar to those from run 60. See Plates 9, 10, 11, and 4, Figure 8. The scour in the vicinity of the dike at RM 246.38 was still in excess of 21 feet, but the downstream extent was less by about 600 feet. No improvement in the meander condition at RM 245 could be detected, although the average navigation depth increased to 10.5 feet.

VI. CONCLUSIONS

63. In general, the objectives of the model study were met. The model reproduced a shifting thalweg similar to that occurring in the prototype; two schemes were found to be successful in stabilizing the thalweg; and the results of the tests have general application to similar problems at other channel crossings.

64. The verification tests (runs 27, 38, 43, and 58) produced a condition in which the depths at the grid points in the crossing varied randomly with time. See plate 7. Even though the average depth at each grid point was greater than the minimum desired, 9 feet, there were periods of time during which the depths at some of these grid points were much less than the minimum desired. See Table II and Plate 4, Figure 1.

65. A problem with the verification tests was discovered toward the end of the test schedule. Shoaling at about RM 245 during these tests prompted a verification check of the model, run 58. At the end of this verification check, additional soundings were obtained upstream and downstream of RM 245, resulting in a more detailed map of the bed contours in this area. These contours indicated that the thalweg in the model split at about RM 245.2. One part continued to follow the concave alignment; the other part was directed toward the scour hole around dike structure 255.8. It is possible that this condition existed during the earlier verification tests but was not observed since efforts at those times were concentrated on the crossing problem. The result of this condition would be to exaggerate shoaling in this area if encouraged by structural changes at the upstream crossing.

66. Two schemes were found which would stabilize the thalweg along the concave alignment of the channel. See Plate 4, Figures 6 and 8. The first scheme requires realigning the crossing structure at RM 246.7, with an offset from the existing alignment to a maximum of 275 feet. See Plate 13. This scheme is not recommended because excessive shoaling developed at RM 245. Major changes to structures downstream of the crossing could possibly correct this problem. The second scheme requires realigning the crossing structure at RM 246.5 with an offset from the existing alignment to a maximum of 275 feet. See Plate 15. This scheme is recommended even though a tendency to shoal was also noticed at RM 245. It is believed that this shoal condition resulted from improper adjustment of the model flow at this location which was not detected until the end of the study. It should be noted that in both schemes an offset of 275 feet from the original alignment was necessary. It would appear that the resulting increase in curvature produced by this magnitude of offset would achieve the desired results regardless of location. It is suggested that any structural changes in this area should also be tested in the backwater mathematical model to determine possible increases in water surface elevations and encroachment on Levee Unit L-246.

67. Information gathered from the preliminary and verification tests proved useful in formalizing generalized information on the crossing problem. The prototype flow distribution data was also of use. An examination of the

prototype flow data (Appendix D) shows that at location A (See Plate 2), the unit discharge in the segment adjacent to the concave bank is about twice the unit discharge along the convex side. However, at B, the unit discharge is almost uniform across the channel. The corresponding channel depths follow the same pattern. Location B is more than a 1/2 mile above the design crossing, yet its flow pattern and channel configuration are more typically that of a crossing. This would seem to indicate that the flow is attempting to cross at this location and probably crosses at low flows as demonstrated by the model in runs 30, 32, 36, and 53. At greater flow depths, the crossing probably moves downstream, but even then it may still be upstream of the design crossing. In a uniform cross section, the thalweg is essentially nonexistent, however, because of the random configuration of the dunes with respect to time a shifting thalweg may appear to exist. A uniform cross section will not present any problem until the average depth approaches the minimum desirable depth. As this occurs, the probability increases that the channel depths will be less than the desirable depth. The maximum height of a dune may approach the average depth of flow, as evidenced by the data on Plate 7. A design based on this concept would require an average depth equal to twice the minimum desired depth, and this is obviously not practical. As it turns out, these occurrences are infrequent, and if the model data are representative, they are also of short duration. This example does illustrate, however, that to assure a minimum depth, an average depth greater than the minimum must be maintained. Some feeling for the magnitude of this extra depth may be obtained from the model depth frequency analysis presented on Plate 8 from test run 43. From this graph, it may be seen that an increase in average depth from 9 feet to 10 feet decreases from 50 percent to 30 percent the probability of the depth being less than 9 feet. An alternate approach to the meandering thalweg problem may be to increase the magnitude of the design flow.

68. An additional observation may be made about the behavior of the predominant thalweg as delineated by frequency maps constructed from the frequency analysis. In most cases, the predominant thalweg did not gradually break toward the opposite bank but departed fairly abruptly at about an angle of 45 degrees to the upstream path. See Plate 4, Figures 2, 6, 7, and 8.

APPENDIX A

REFERENCES

References

1. Missouri River Division, Corps of Engineer, "Operation and Function of the Mead Hydraulic Laboratory." MRD Hydraulic Laboratory Series Report No. 1, March 1969.
2. Missouri River Division, Corps of Engineer, "Laboratory Investigation of Underwater Sills on the Convex Bank of Pomeroy Bend." MRD Hydraulic Laboratory Series Report No. 2, November 1966.
3. Missouri River Division, Corps of Engineers, "Suspended Sediment in the Missouri River." Daily Record for Water Years 1960-1964, October 1970.
4. Missouri River Division, Corps of Engineers, "Suspended Sediment in the Missouri River." Daily Record for Water Years 1965-1969, May 1972.
5. Missouri River Division, Corps of Engineers, "Suspended Sediment in the Missouri River." Daily Record for Water Years 1970-1974, April 1976.

APPENDIX B

PHOTOS

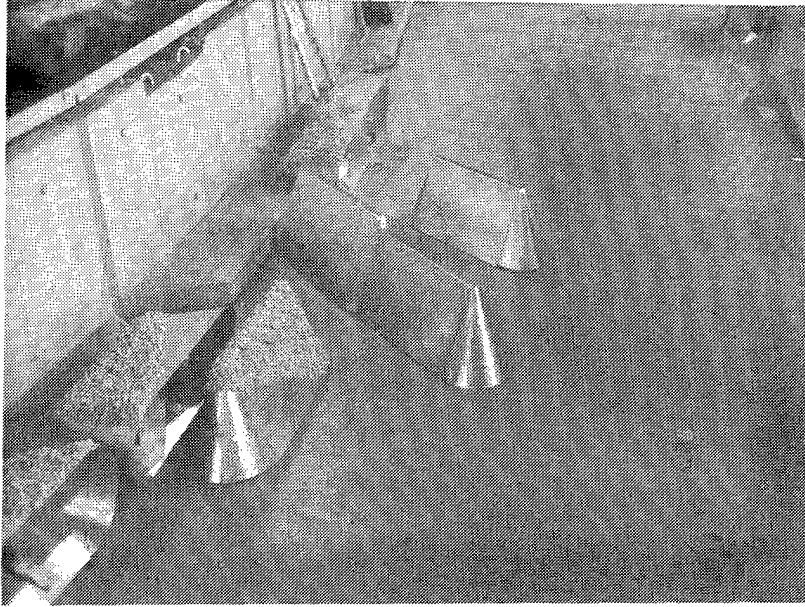

1

View of Model Dike Structures constructed of sheet metal with stone glued to surface to simulate prototype stone roughness.

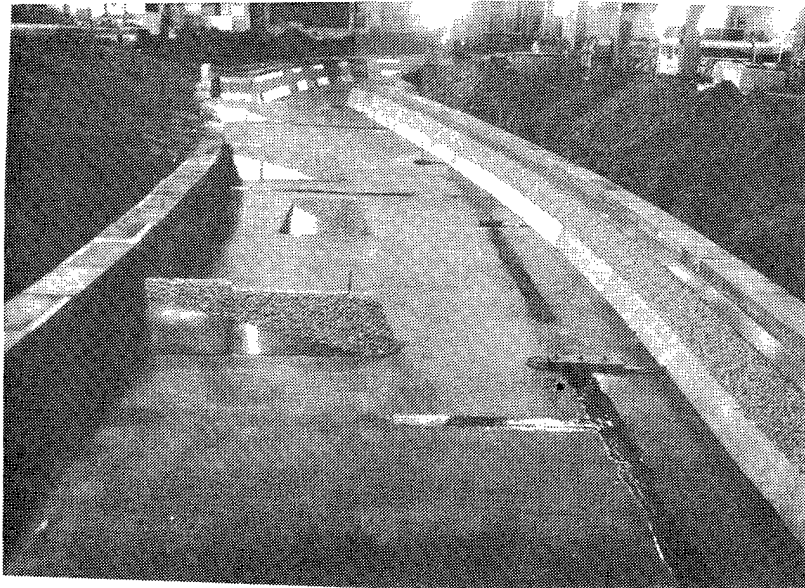

2

View downstream from RM 247.7 toward crossing at RM 246.2, showing model construction methods. Dike structures at left abutted concrete block wall along convex bank. Sheet metal with stone attached was placed against block wall on right to form revetment.

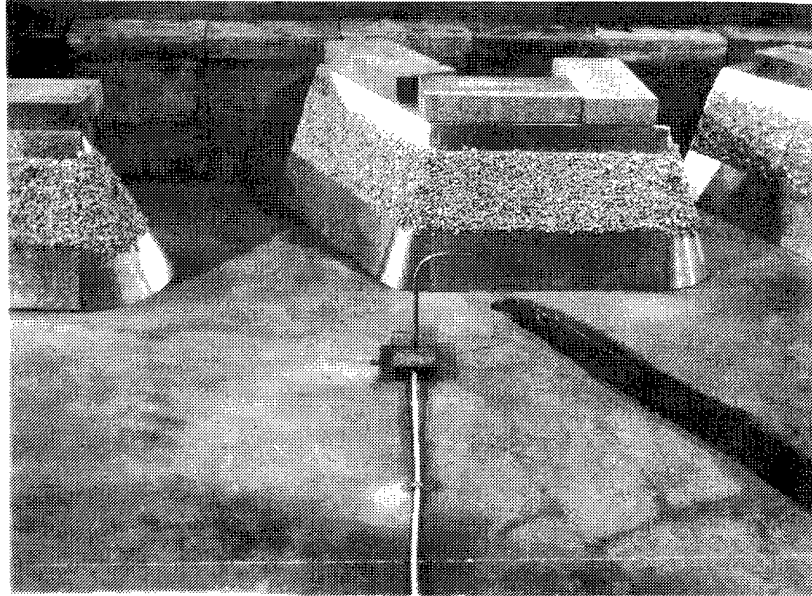

3

View of one of the devices used to monitor water surface elevations in model. Flow will be from left to right. Structures in back are "L" heads in Bushwacker Bend.

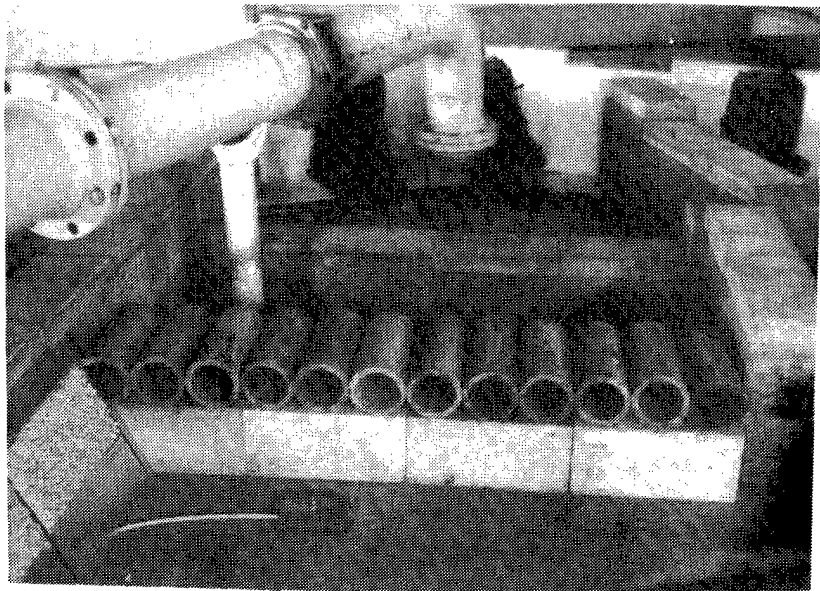

4

View of model entrance, showing recirculation line at top of photo and tile drain drain pipe used to control flow distribution.

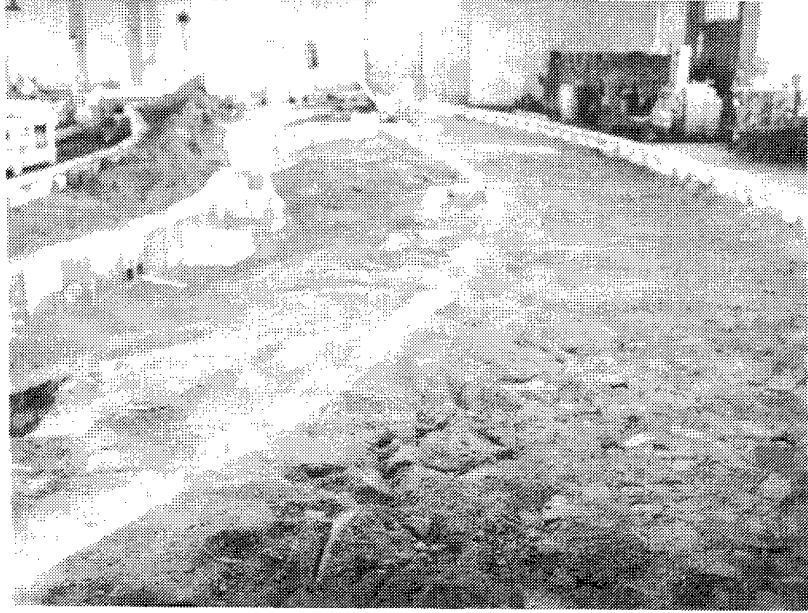

5 View upstream from about RM 245 during process of back-filling channel and bank areas with ground walnut shells.

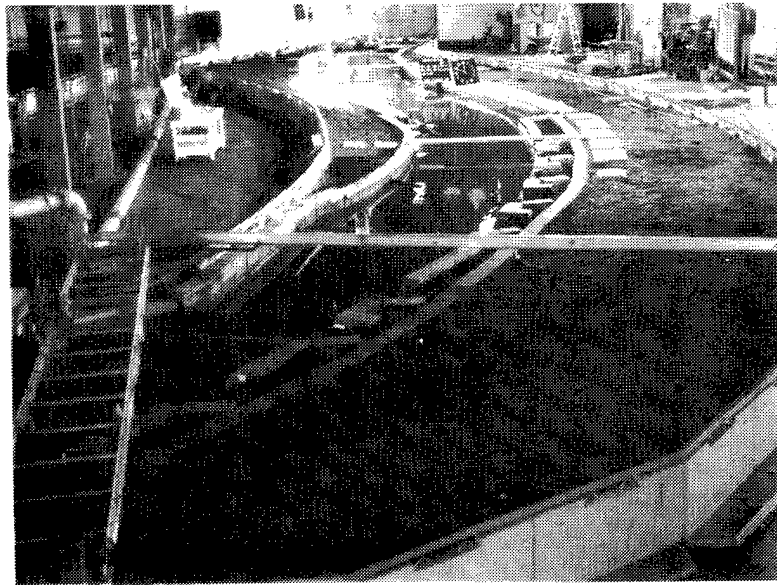

6 View upstream at Bushwacker Bend Model during Run 56.

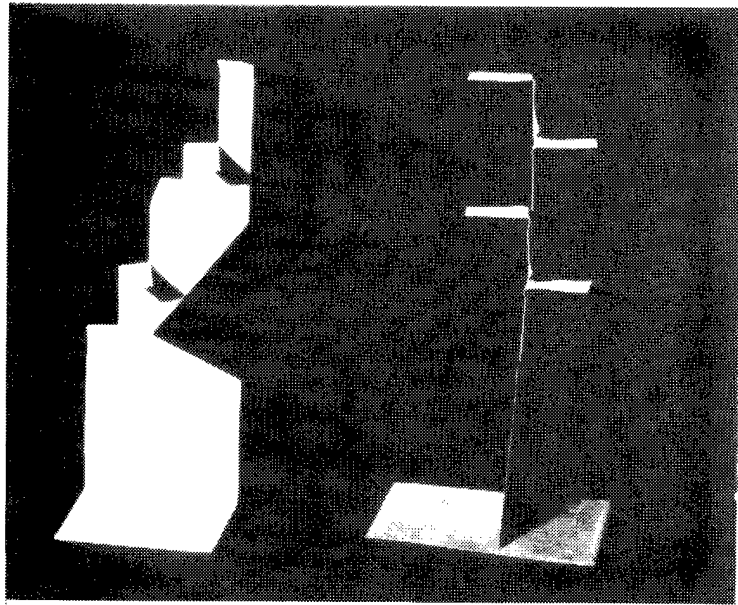

7 View of devices used to indicate depth in crossing on time lapse photos.

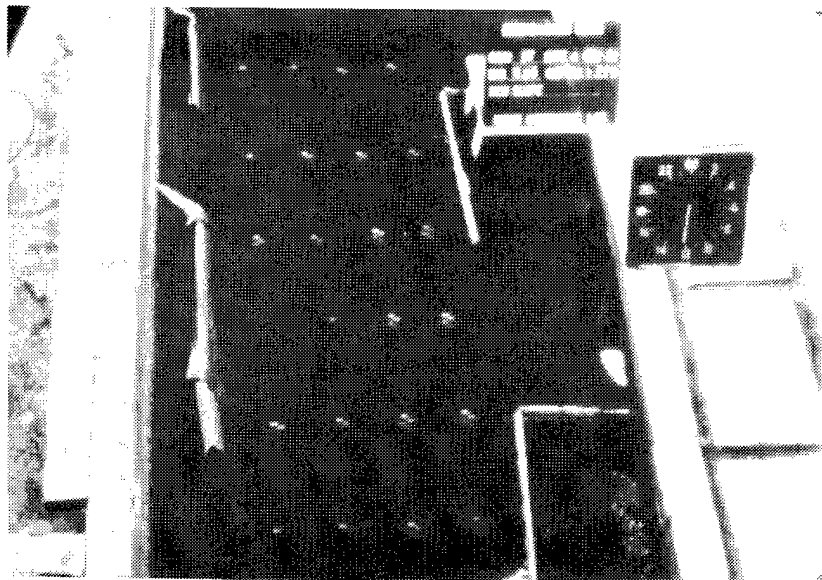

8 View of crossing through time lapse camera showing depths at depth indicators during Run 57 at hour 36.5.

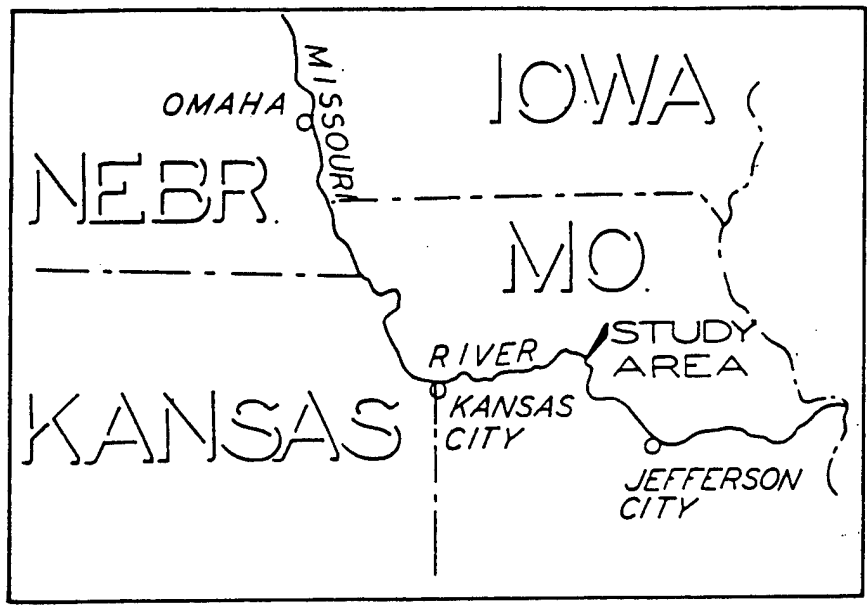

LOCATION MAP

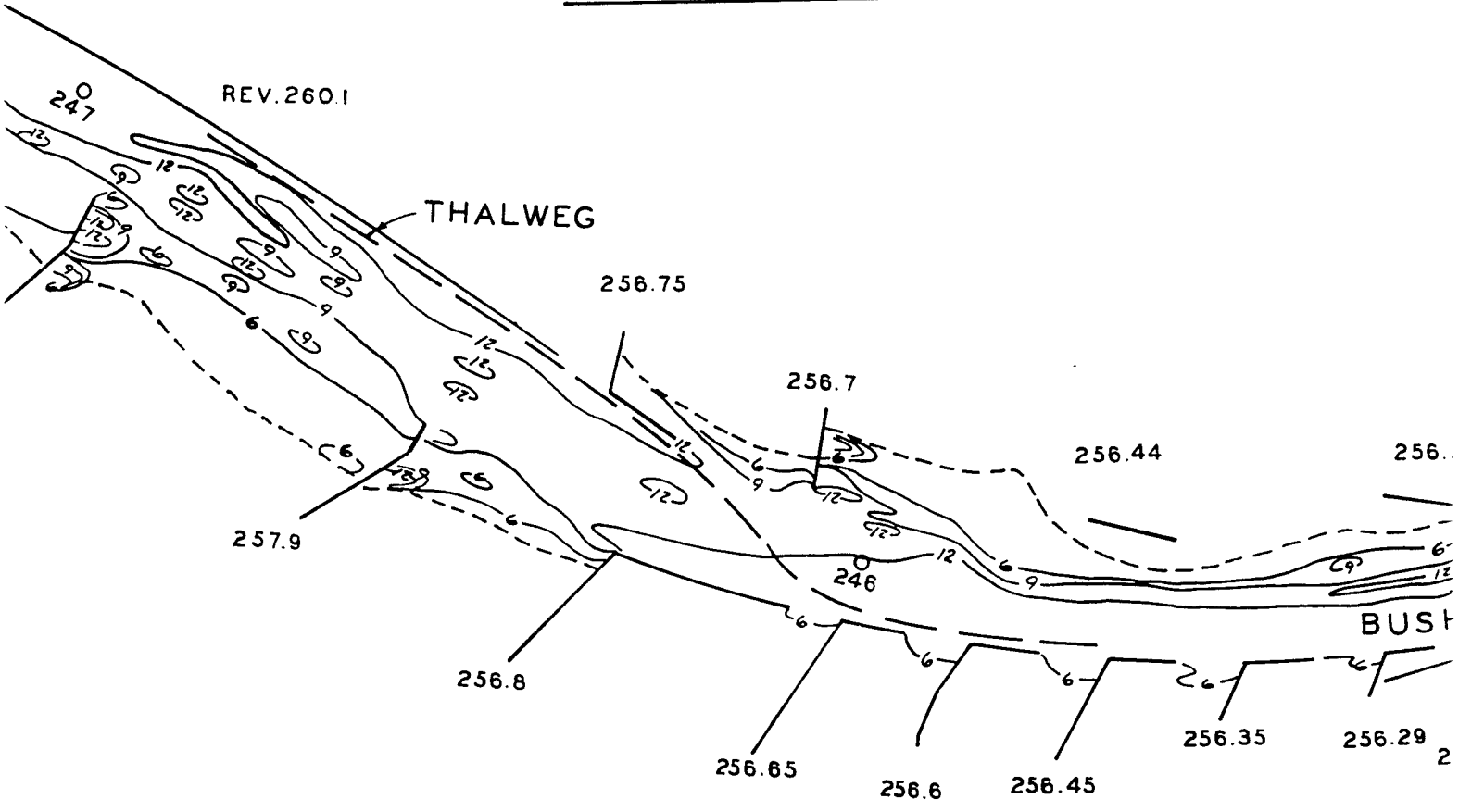
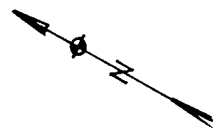

NOTE: SEE

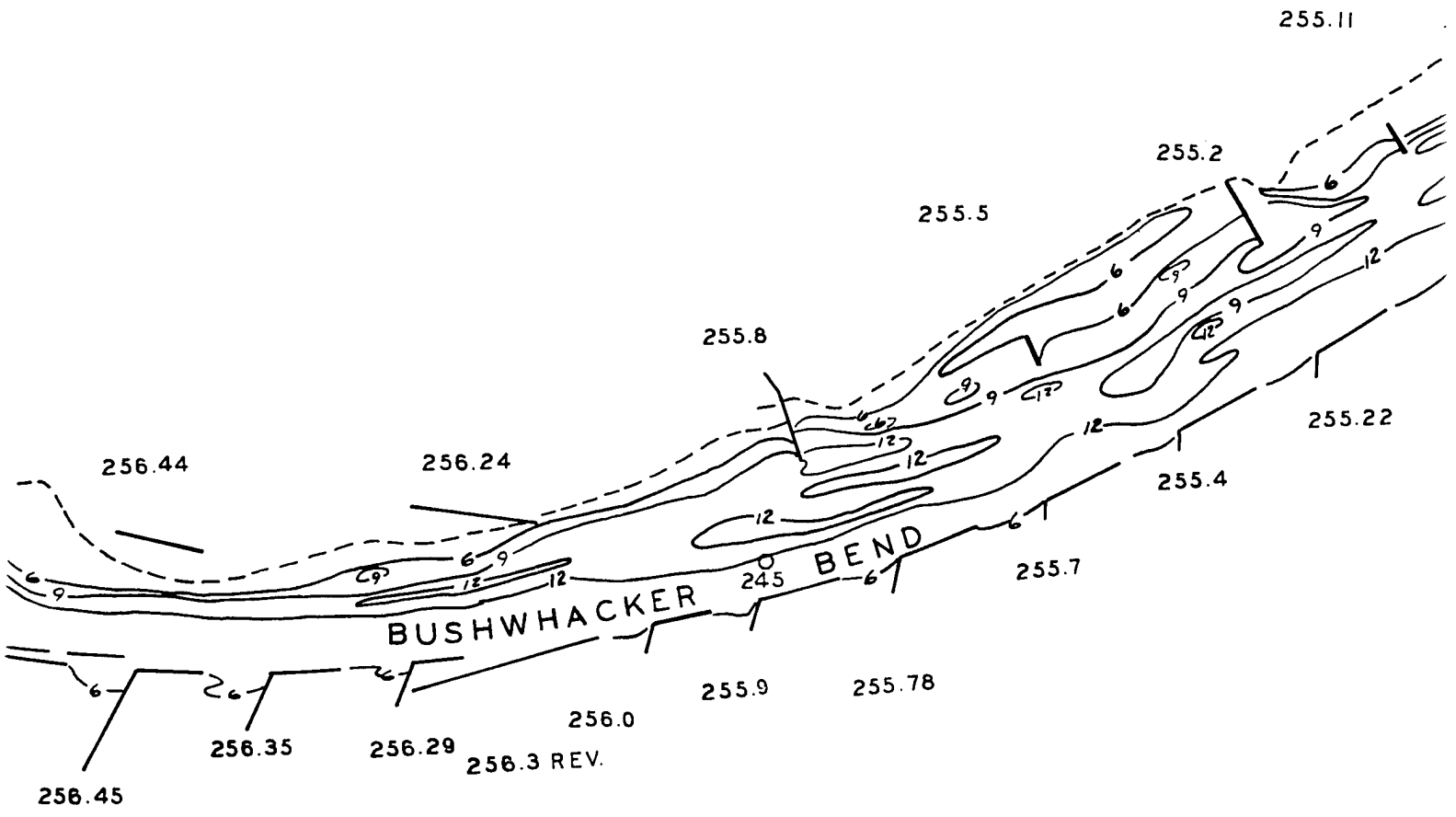
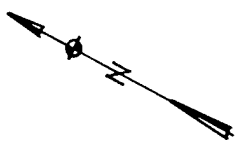
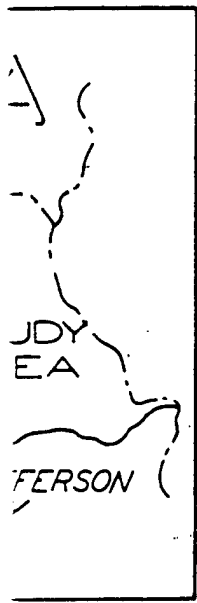

NOTE: SEE PLATE 2 FOR NOTES.

MEAD HYDRAULIC I
BUSHWHACK
LOCATION M
1980 HYDROGRAPH

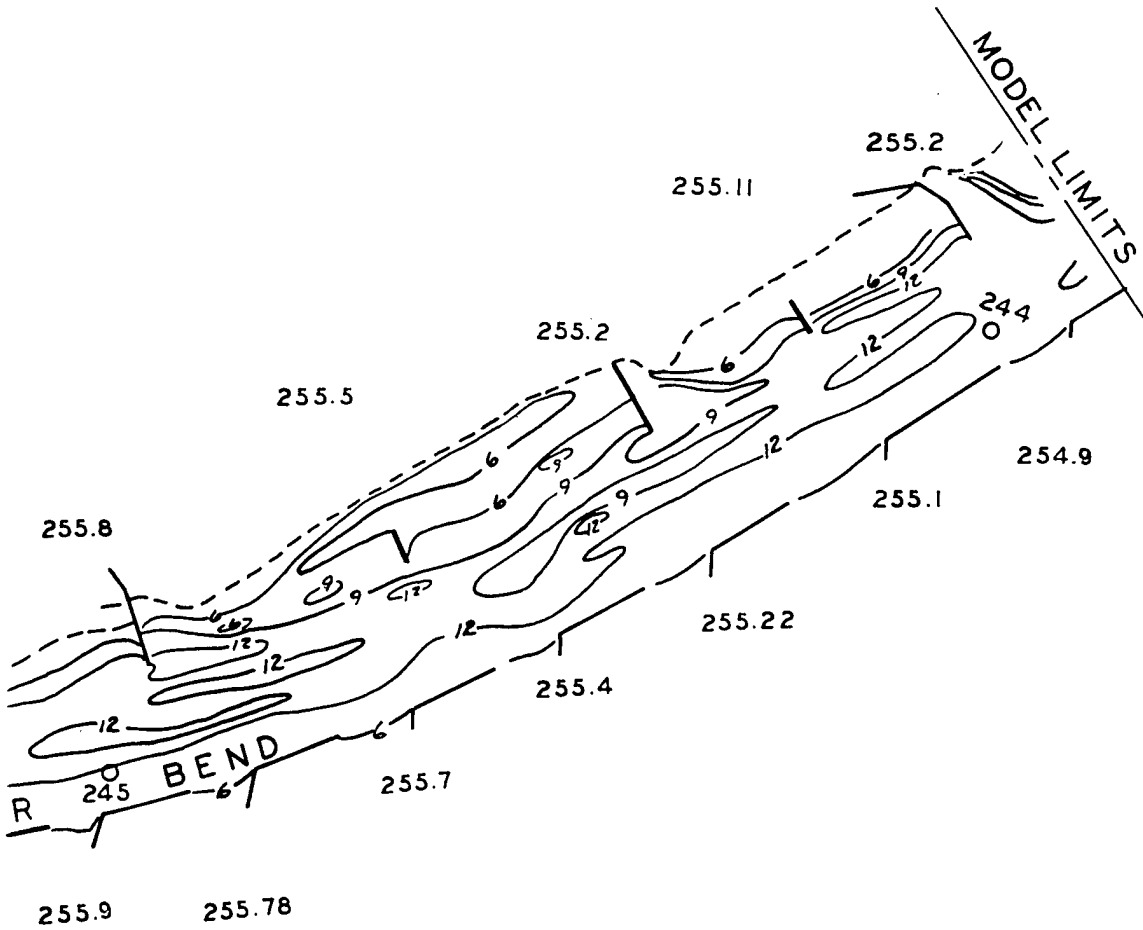

OR NOTES.

MEAD HYDRAULIC LABORATORY
BUSHWHACKER BEND
 LOCATION MAP AND
 1980 HYDROGRAPHIC SURVEY

④

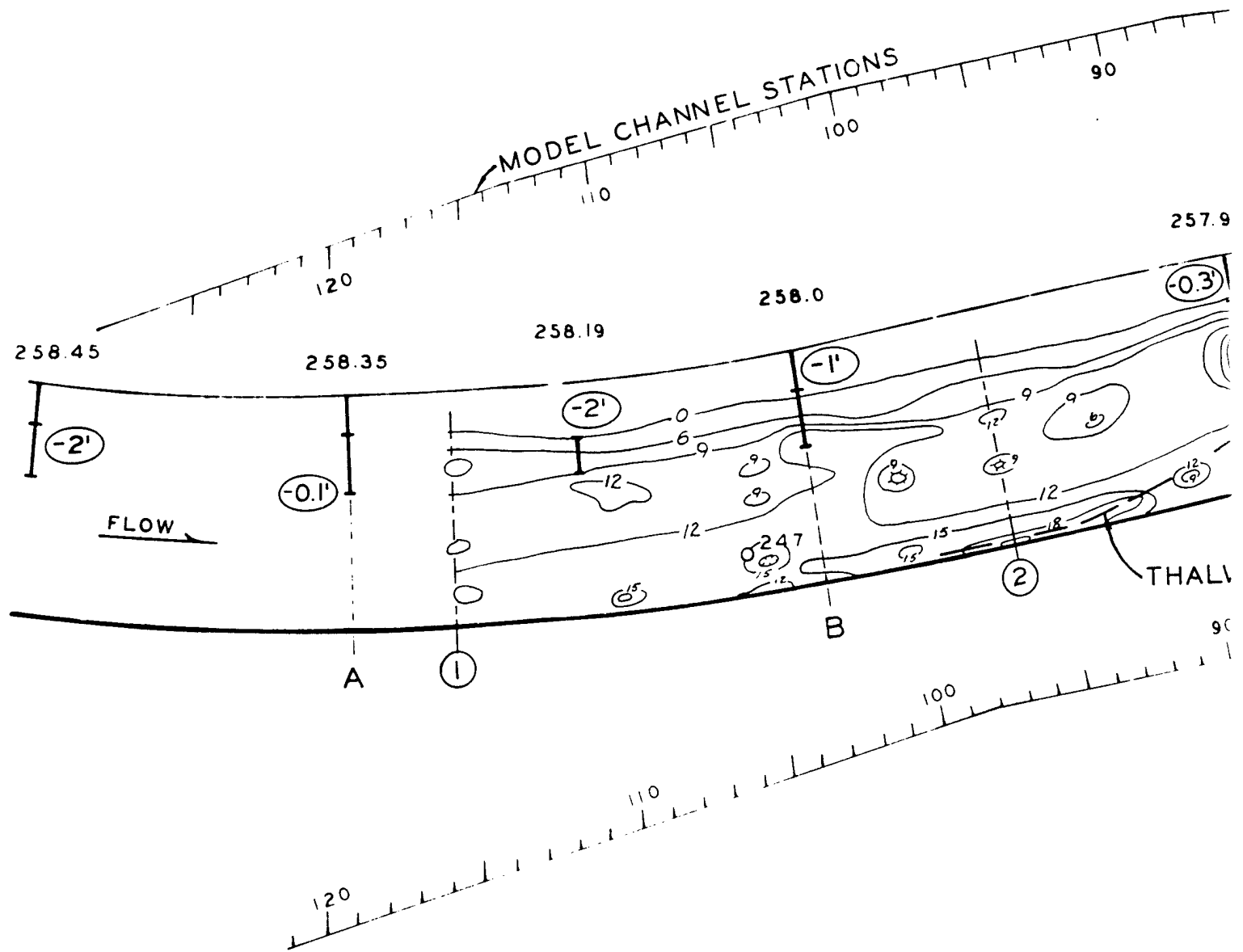

PROTOTYPE SCALE IN 100'

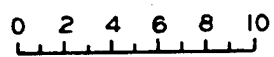

MODEL SCALE IN FEET

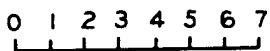

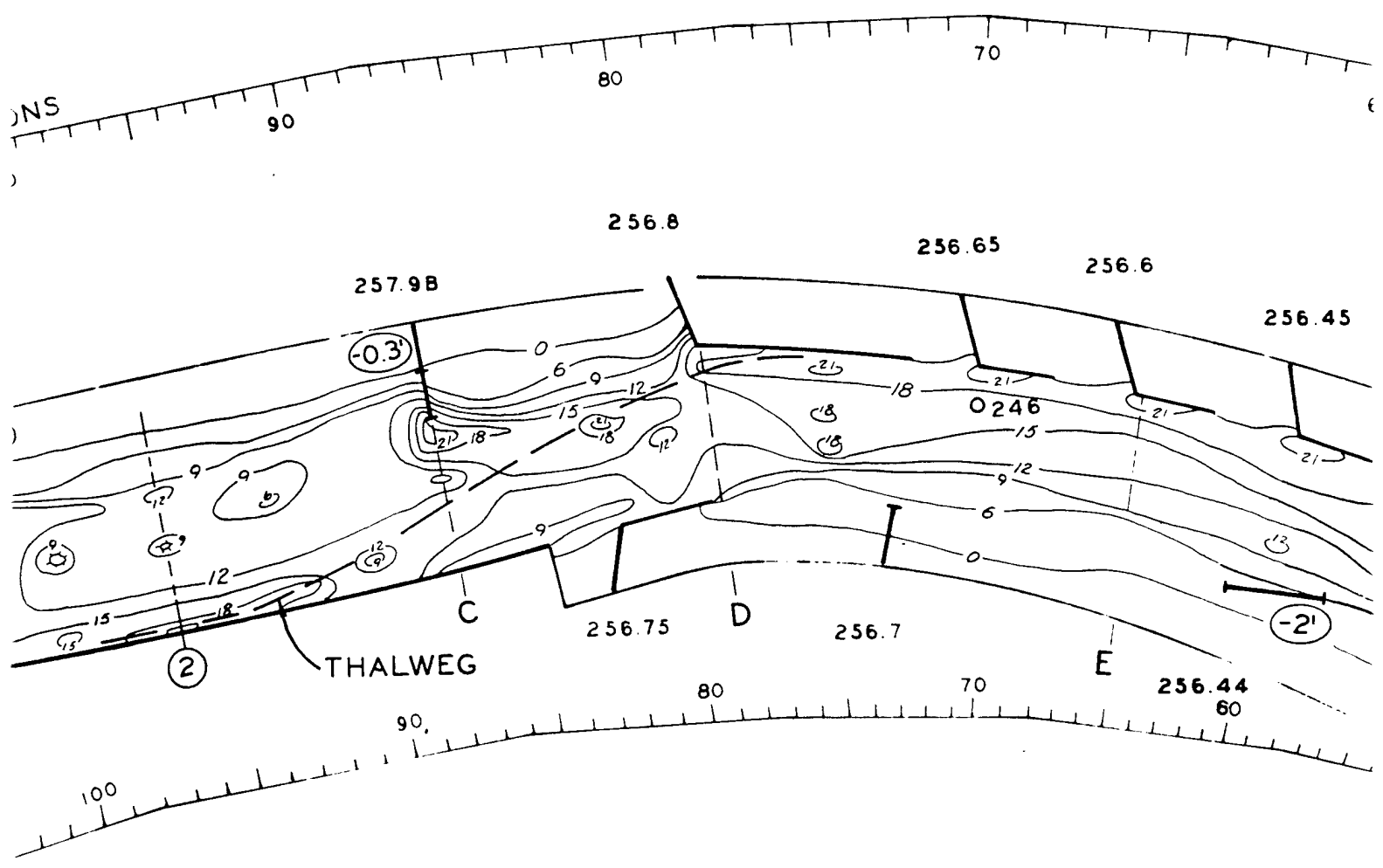

NOTES:

1. NUMBERS BY CONTOURS ARE PROTOTYPE WATER DEPTHS BELOW C.R.P. CONVERTED FROM MODEL DATA.
2. LOCATIONS A THROUGH F ARE FLOW DISTRIBUTION MONITORING STATIONS.
3. LOCATIONS ① THROUGH ④ ARE CROSS SECTION CONTROL STATIONS.
4. NUMBERS BY SILLS ② INDICATE ELEVATION OF SILL WITH RESPECT TO C.R.P.
5. ——— INDICATES SILL LENGTH.
6. O 245 = RIVER MILE LOCATION AND NUMBER. (196)
7. 255.8 = STRUCTURE NUMBER
8. MODEL IS MIRROR IMAGE OF PROTOTYPE.

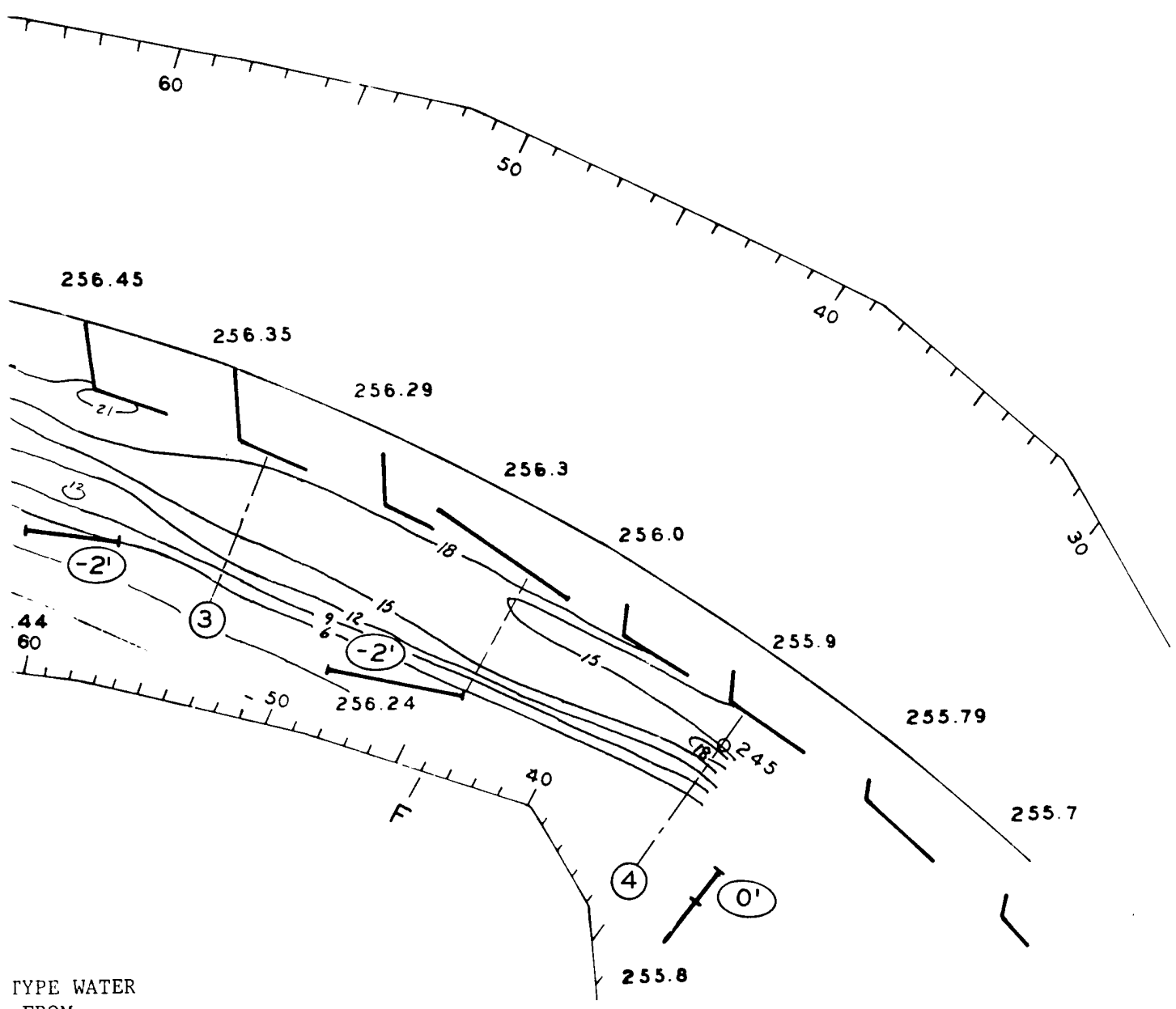

TYPE WATER
FROM

W DISTRIBUTION

SS SECTION

TE ELEVATION

D NUMBER.(1960)

OTYPE.

MEAD HYDRAULIC LABORATORY
BUSHWHACKER BEND
 PARTIAL MODEL LAYOUT WITH
 BED CONTOURS FROM RUN 27

③

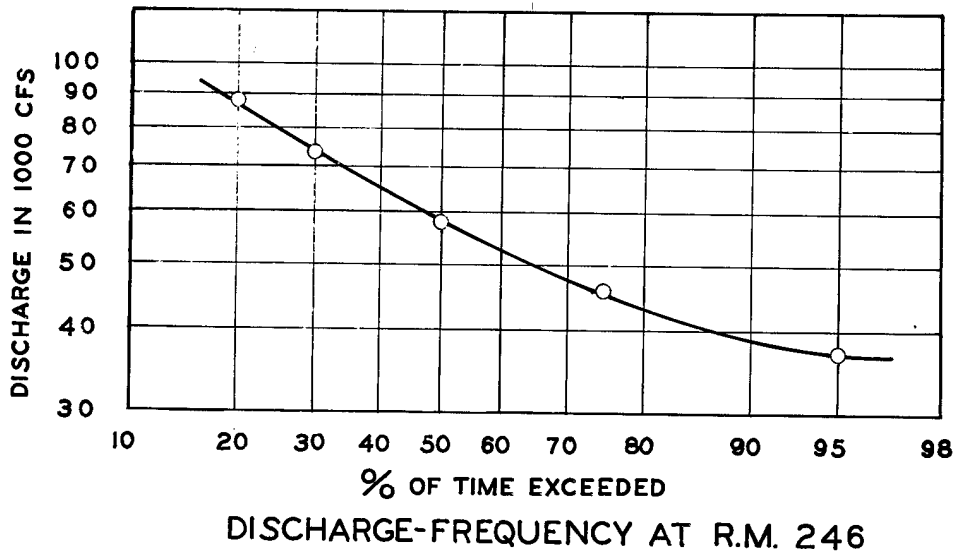
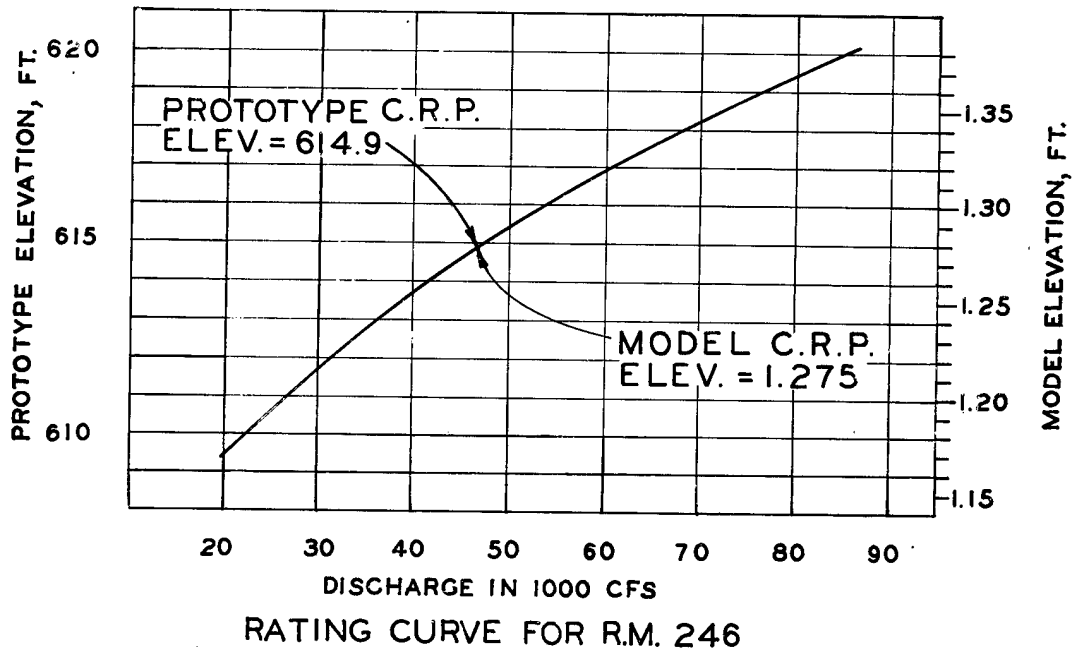

MEAD HYDRAULIC LABORATORY
BUSHWACKER BEND
 DISCHARGE RATING AND
 DISCHARGE FREQUENCY CURVES
 FOR R.M. 246

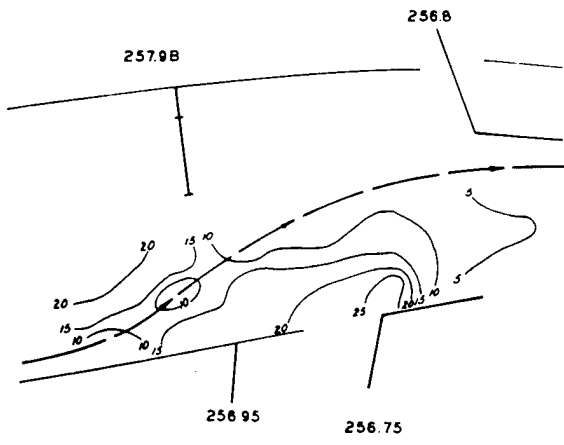

VERIFICATION CONDITIONS
 COMPOSITE OF RUNS 24, 25, 27, 28, 39, 42 & 43
 FIGURE 1

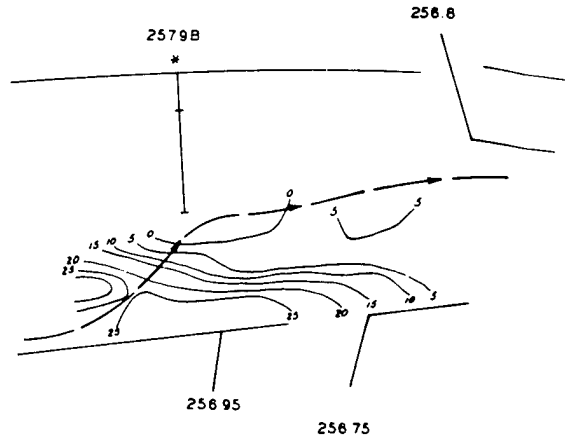

END SILLS EXTENDED
 COMPOSITE OF RUNS 29, 40 AND 45
 FIGURE 2

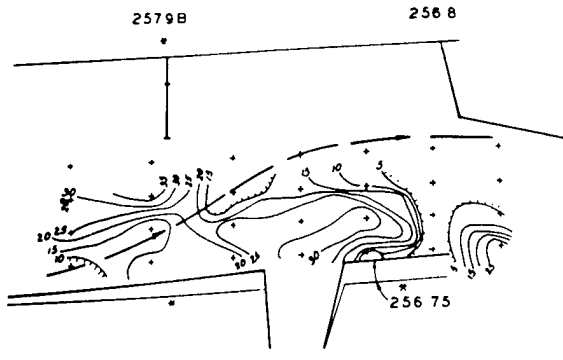

ALIGNMENT NO. 1
 RUN 48
 FIGURE 5

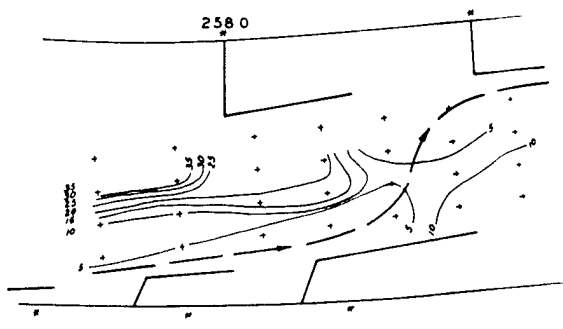

ALIGNMENT NO. 2
 COMPOSITE OF RUNS 51, 52, 55 & 56
 FIGURE 6

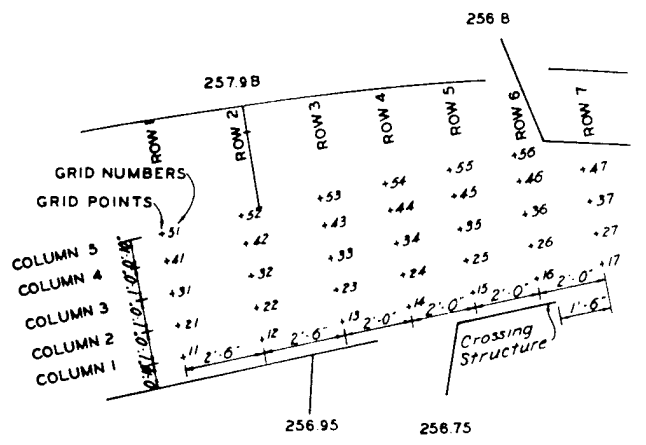

GRID LAYOUT FOR DEPTH INDICATORS
 FIGURE 9

- NOTES:
1. NUMBERS BY CONTOURS OF TIME DEPTHS WERE L
 2. DASHED LINE INDICATES PREDOMINANT THALWEG
 3. MODEL IS MIRROR IMAGE
 4. *NEW OR MODIFIED STRUCTURE

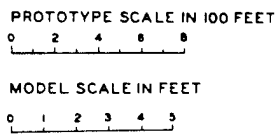

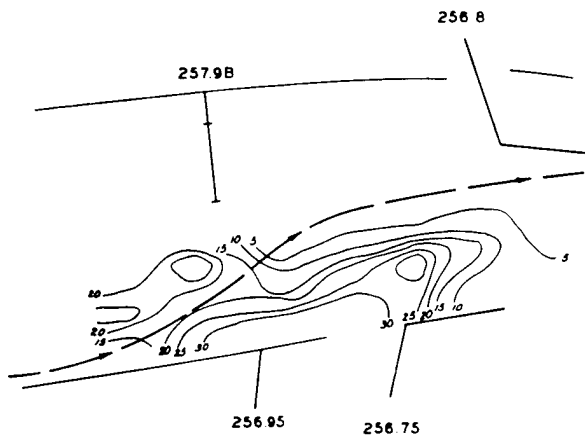

EXTRA DIKE
COMPOSITE OF RUNS 31, 44 AND 50
FIGURE 3

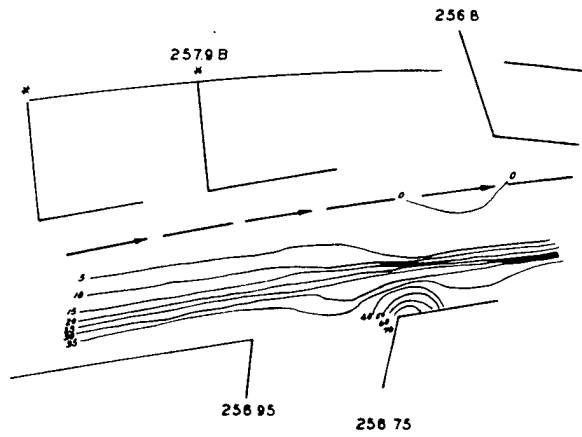

COMBINATION
RUN 49
FIGURE 4

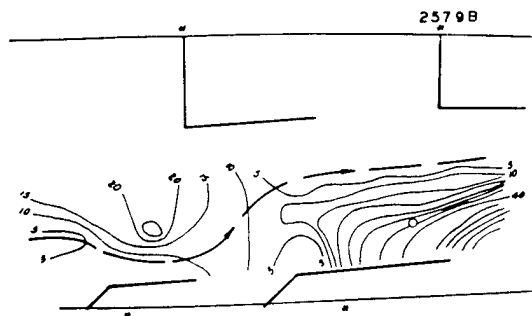

ALIGNMENT NO. 3
RUN 57
FIGURE 7

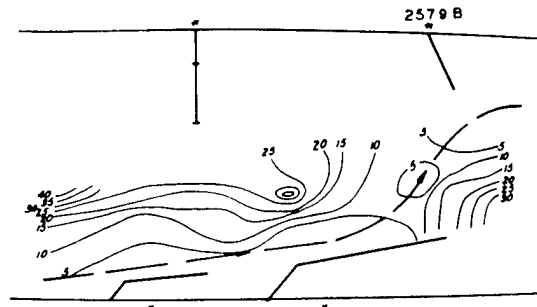

ALIGNMENT NO. 4
COMPOSITE OF RUNS 80 AND 81
FIGURE 8

ES
UMBERS BY CONTOURS INDICATE %
F TIME DEPTHS WERE LESS THAN 9'
ASHED LINE INDICATES PATH OF
REDOMINANT THALWEG
ODEL IS MIRROR IMAGE OF PROTOTYPE
EW OR MODIFIED STRUCTURES.

MEAD HYDRAULIC LABORATORY
BUSHWHACKER BEND
DESIGN DEPTH EXCEEDENCE FREQUENCY
MAPS FOR SELECTED TESTS

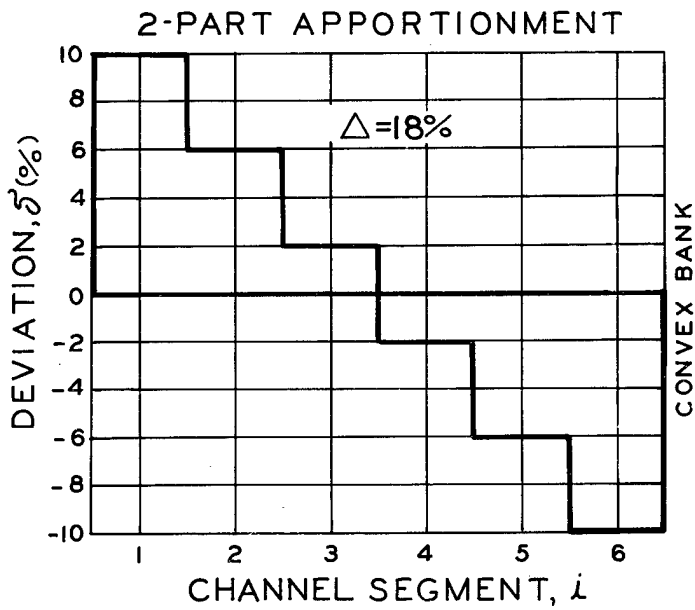

FIG. 1

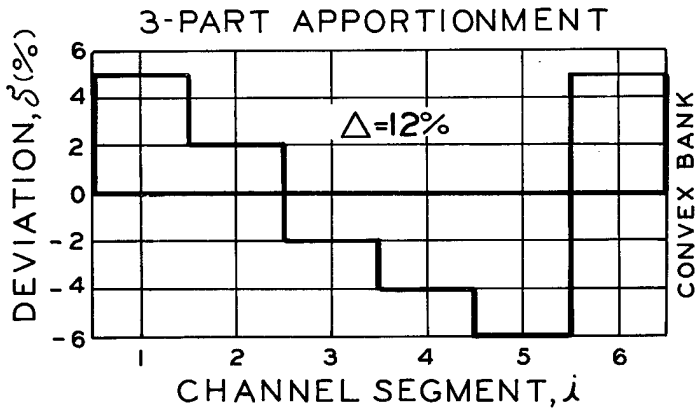

FIG. 2

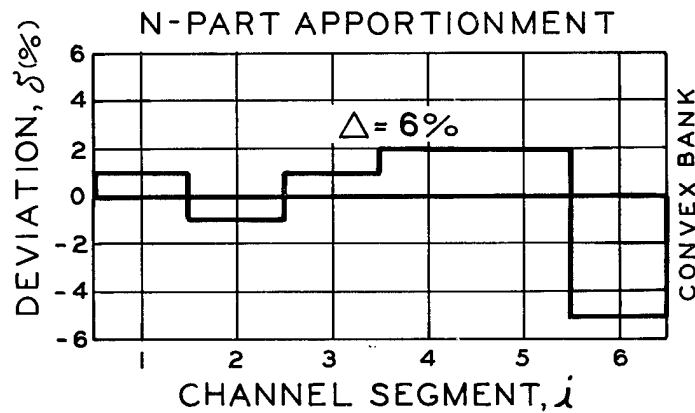
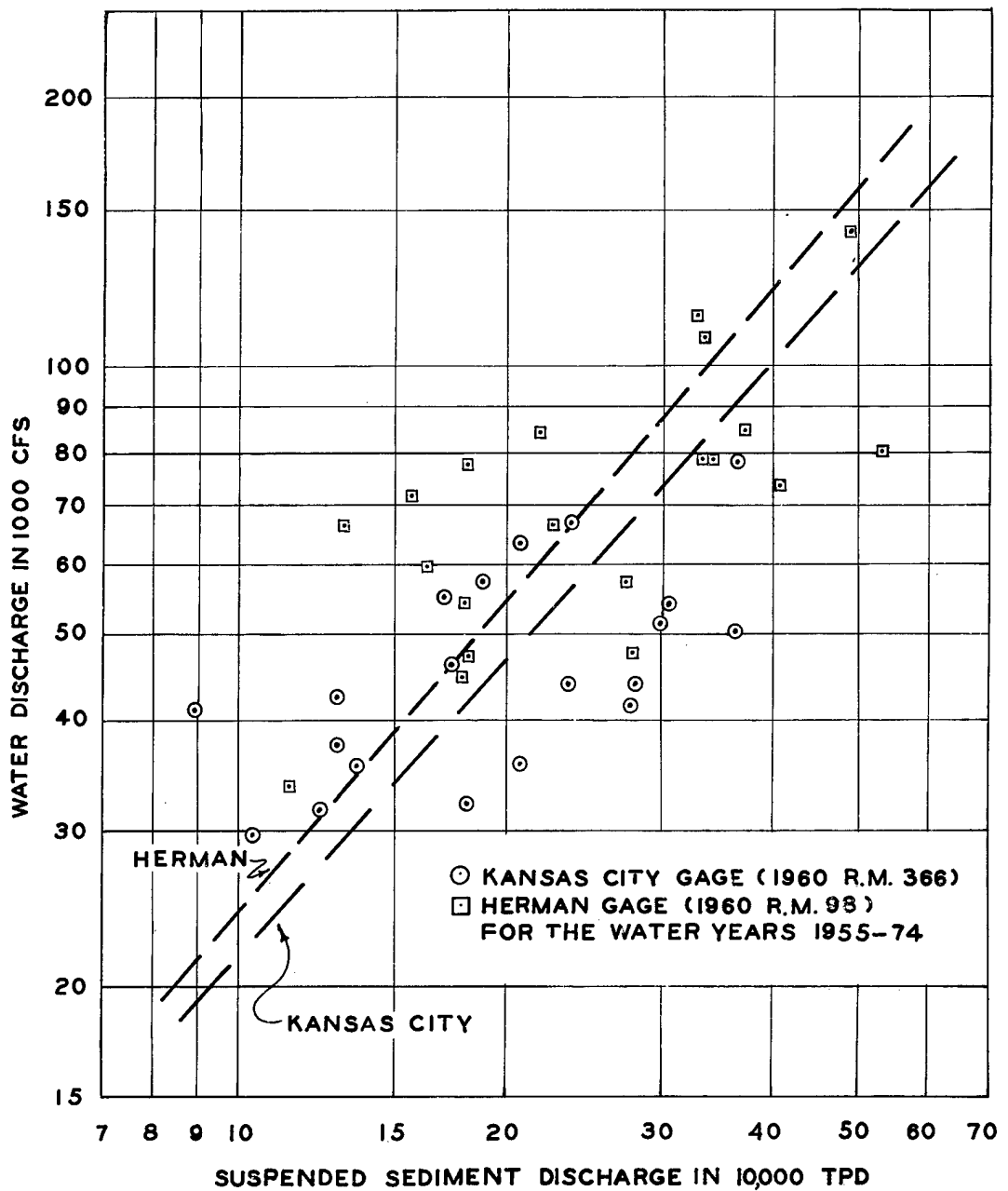

FIG. 3

$$\Delta = \frac{\sum |\delta_i|}{2} \quad \sum \delta_i = 0$$

MEAD HYDRAULIC LABORATORY
BUSHWACKER BEND
 FLOW DEVIATION APPORTIONMENTS



MEAD HYDRAULIC LABORATORY
BUSHWHACKER BEND
 WATER DISCHARGE VS
 SUSPENDED SEDIMENT DISCHARGE
 FOR MISSOURI RIVER

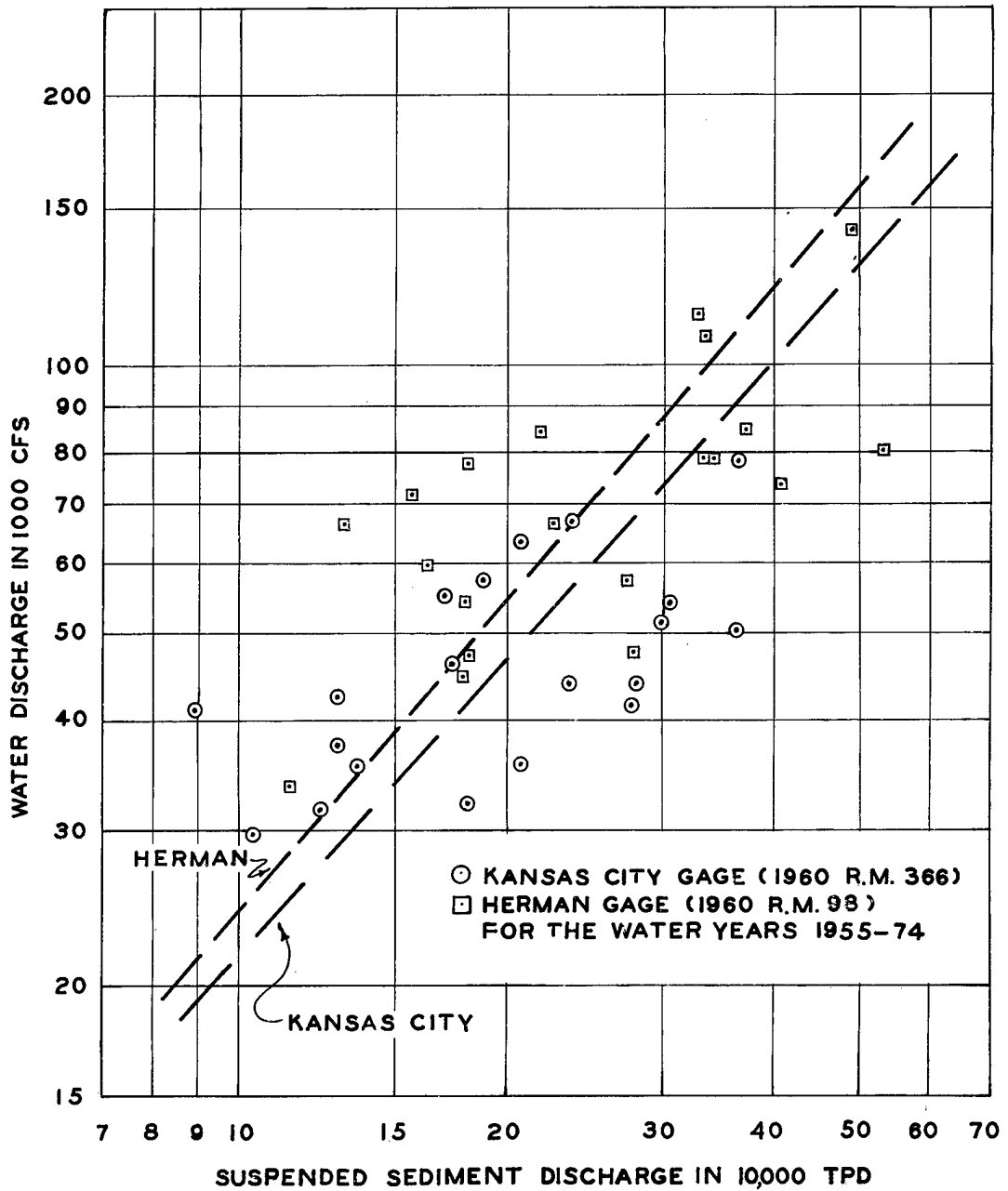

MEAD HYDRAULIC LABORATORY
BUSHWHACKER BEND
 WATER DISCHARGE VS
 SUSPENDED SEDIMENT DISCHARGE
 FOR MISSOURI RIVER

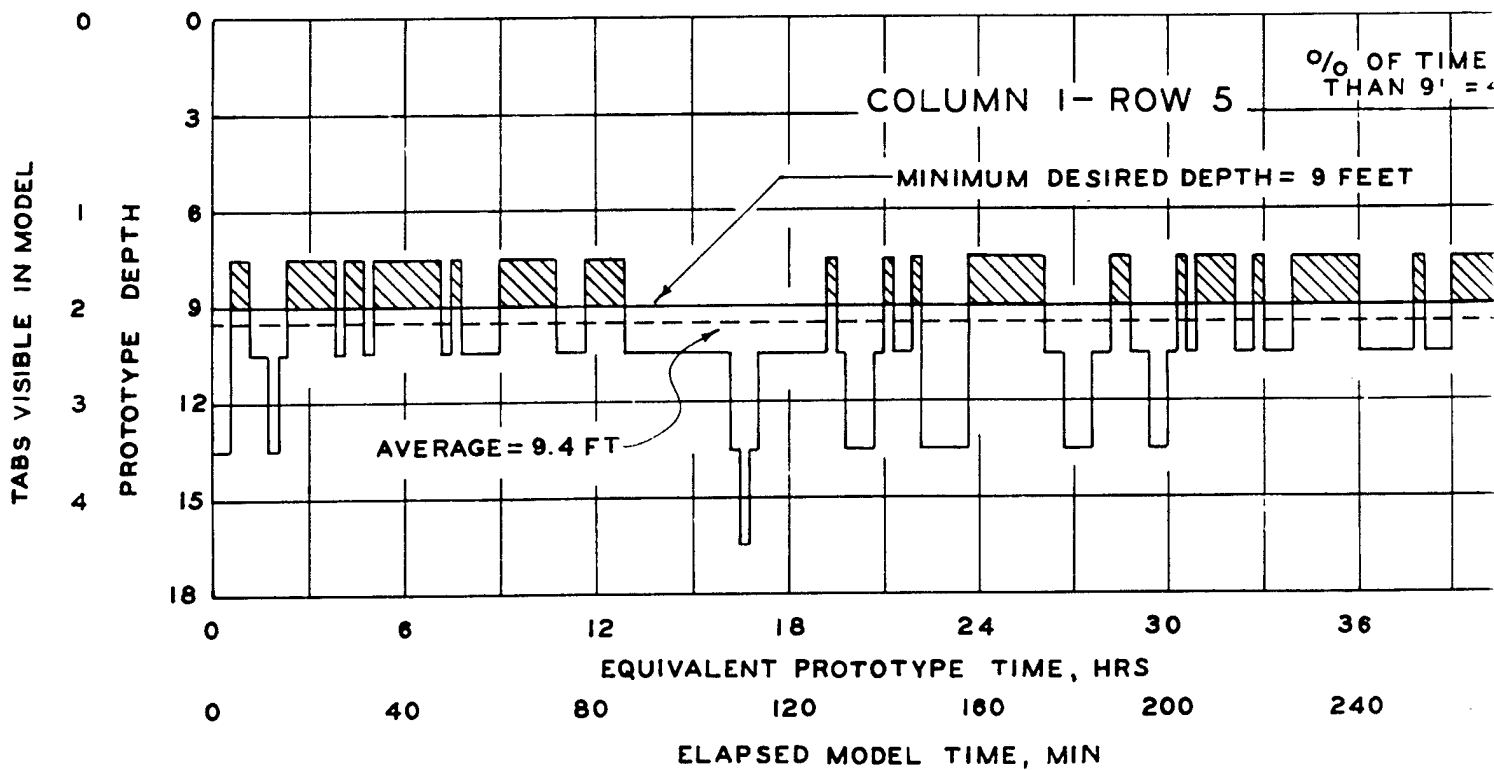
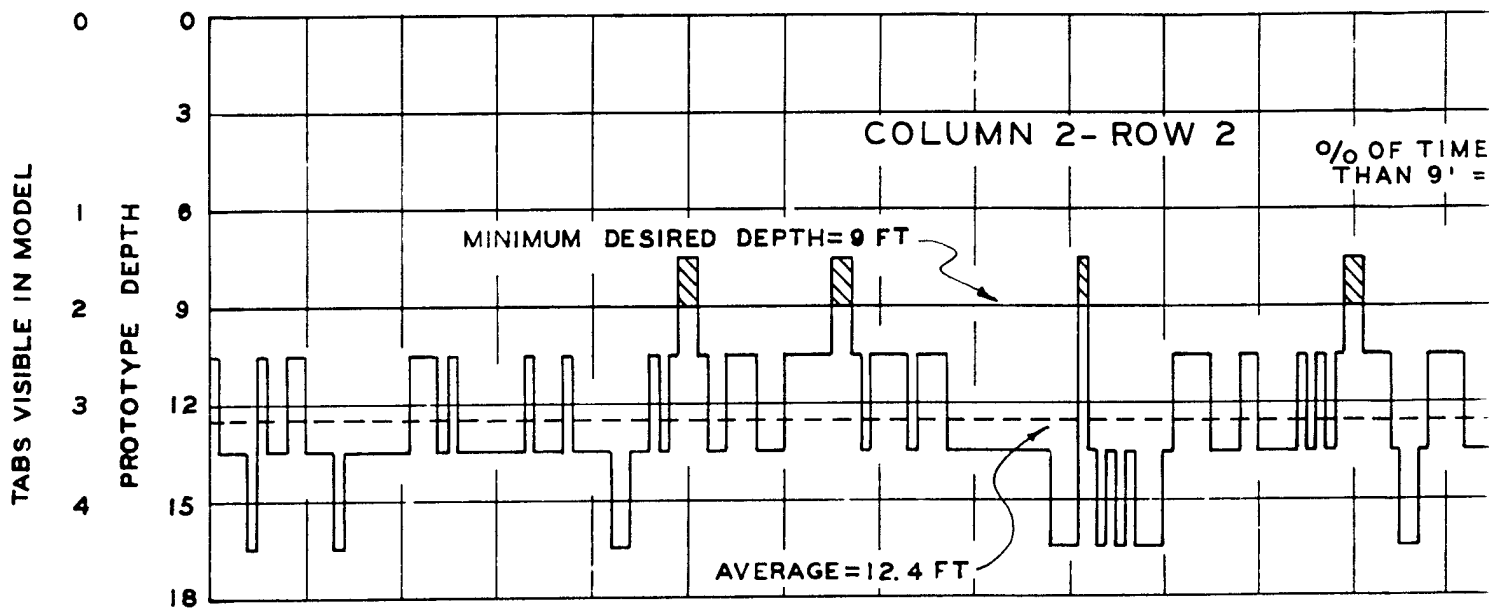

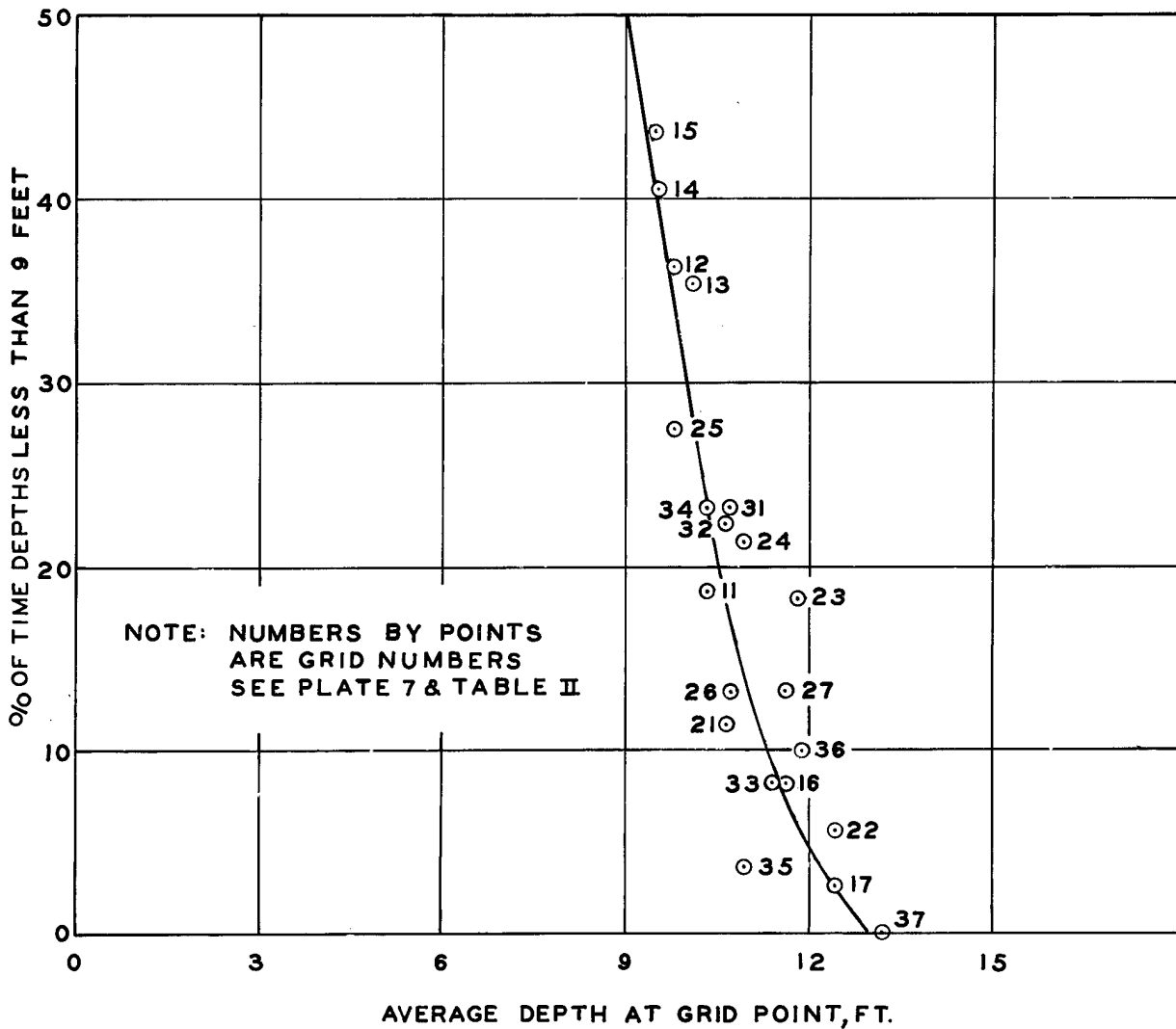

MEAD HYDRAULIC LABORATORY
BUSHWHACKER BEND
 AVERAGE OBSERVED DEPTHS VS
 DESIGN DEPTH EXCEEDENCE FREQUENCIES
 DURING RUN 43

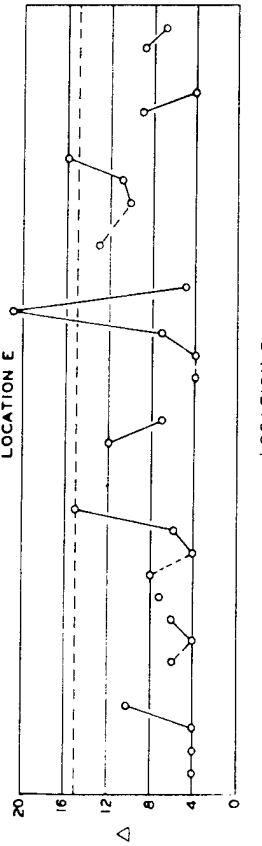
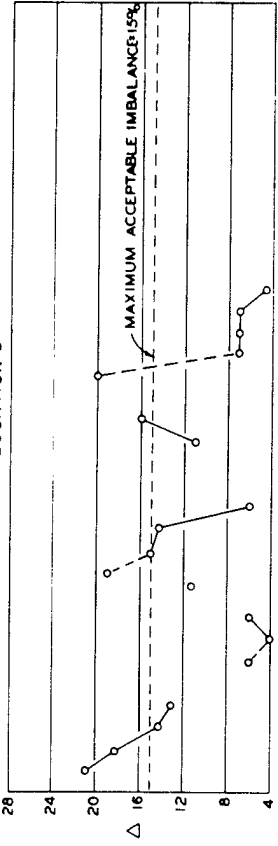
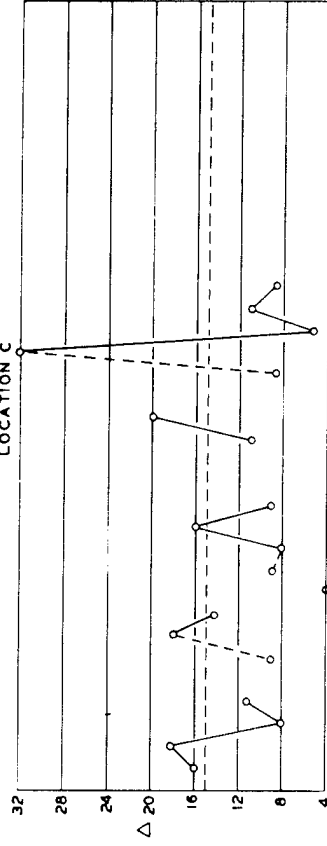
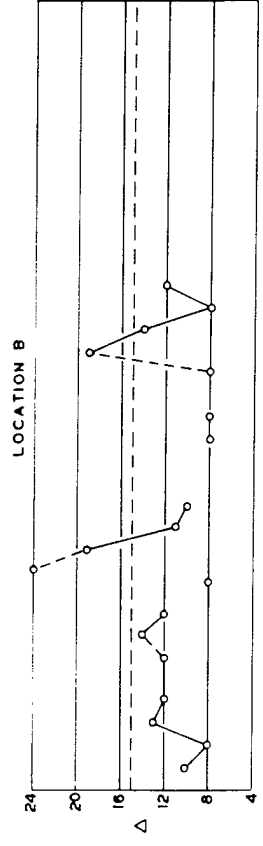
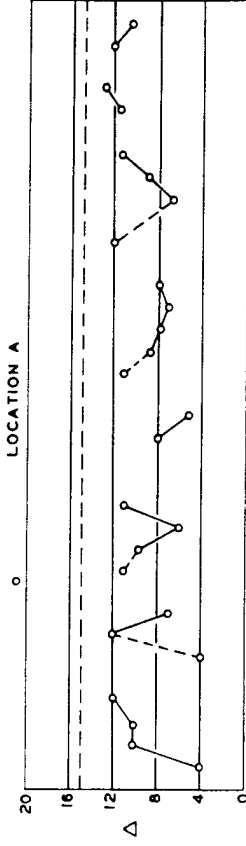

LOCATION F

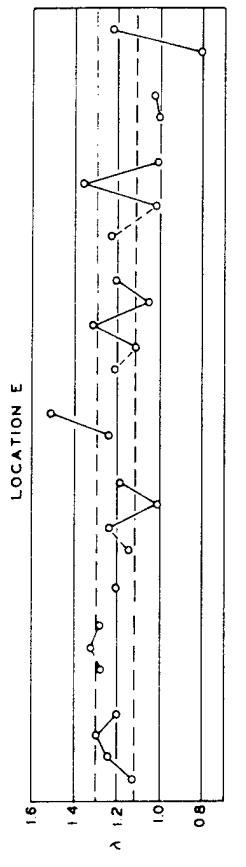
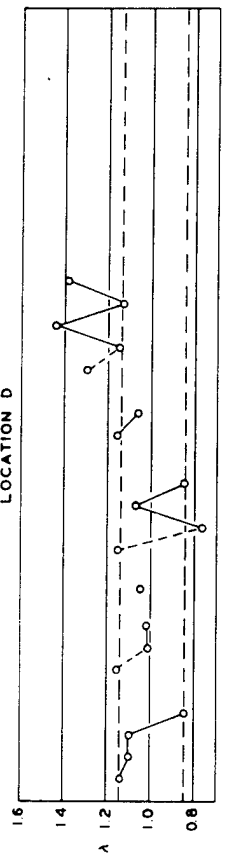
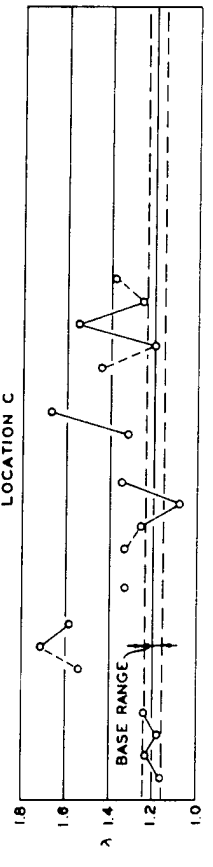
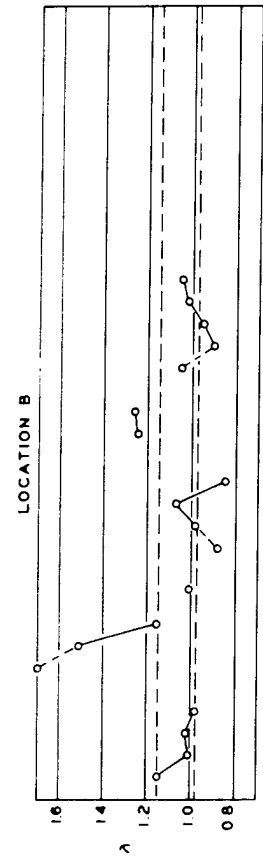
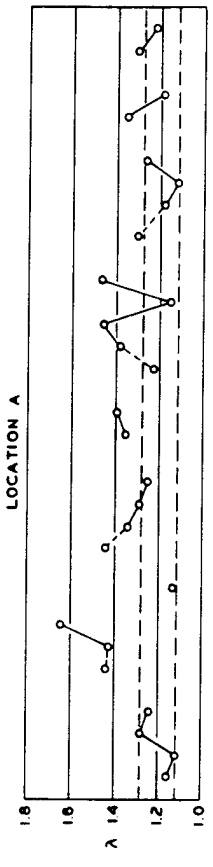

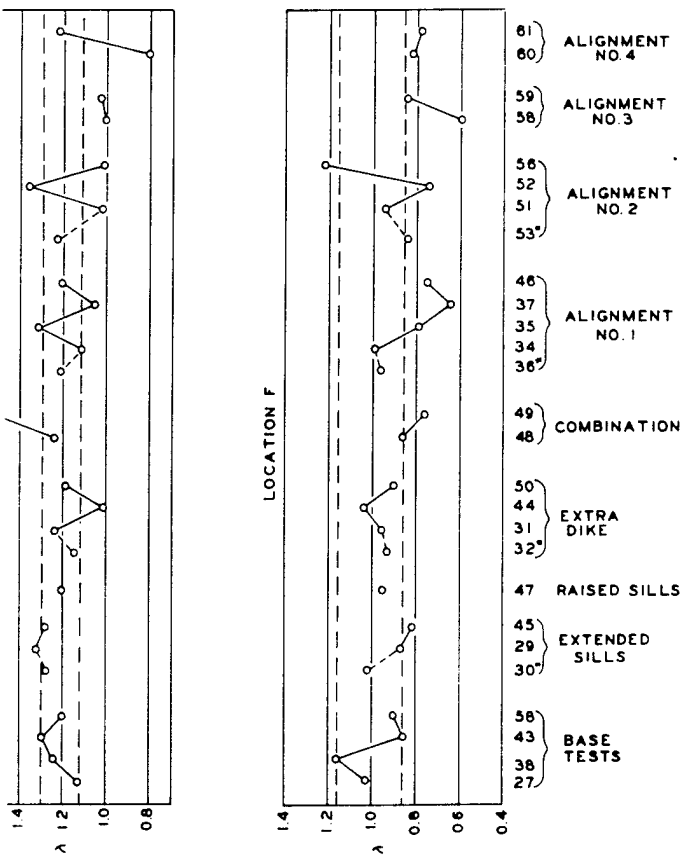

TYPE OF TEST AND RUN NUMBER
FIGURE 2

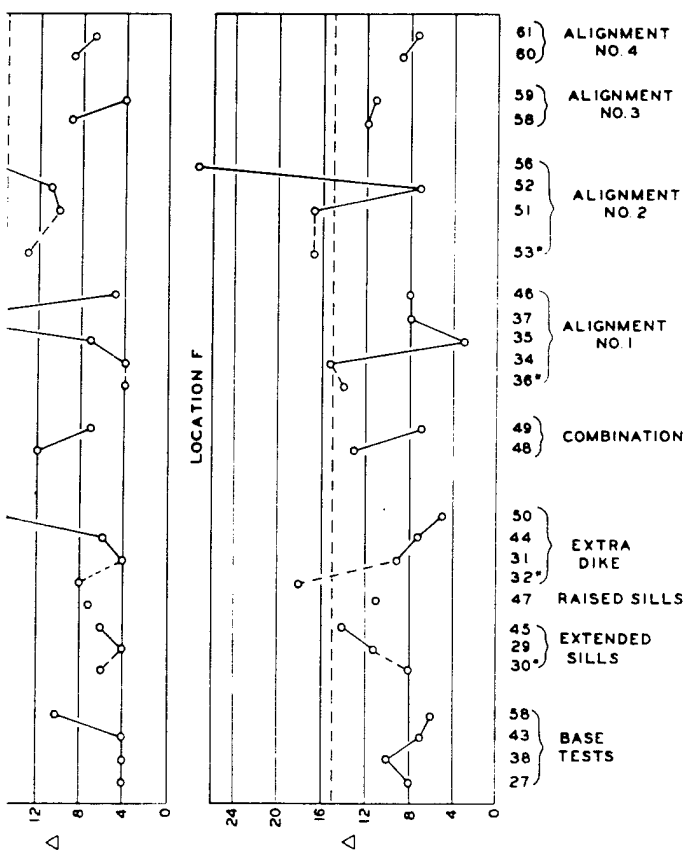

TYPE OF TEST AND RUN NUMBER
FIGURE 1

NOTES:
1. # LOW FLOW TESTS
2. SEE PLATE 2 FOR LOCATIONS A-F

MEAD HYDRAULIC LABORATORY
BUSHWHACKER BEND
FLOW DISTRIBUTION IMBALANCE VALUES
AND DISCHARGE RATIOS AT
LOCATIONS A THROUGH F

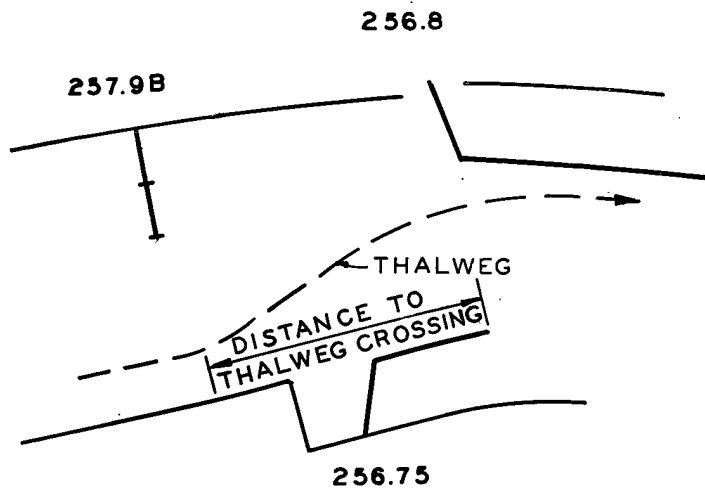
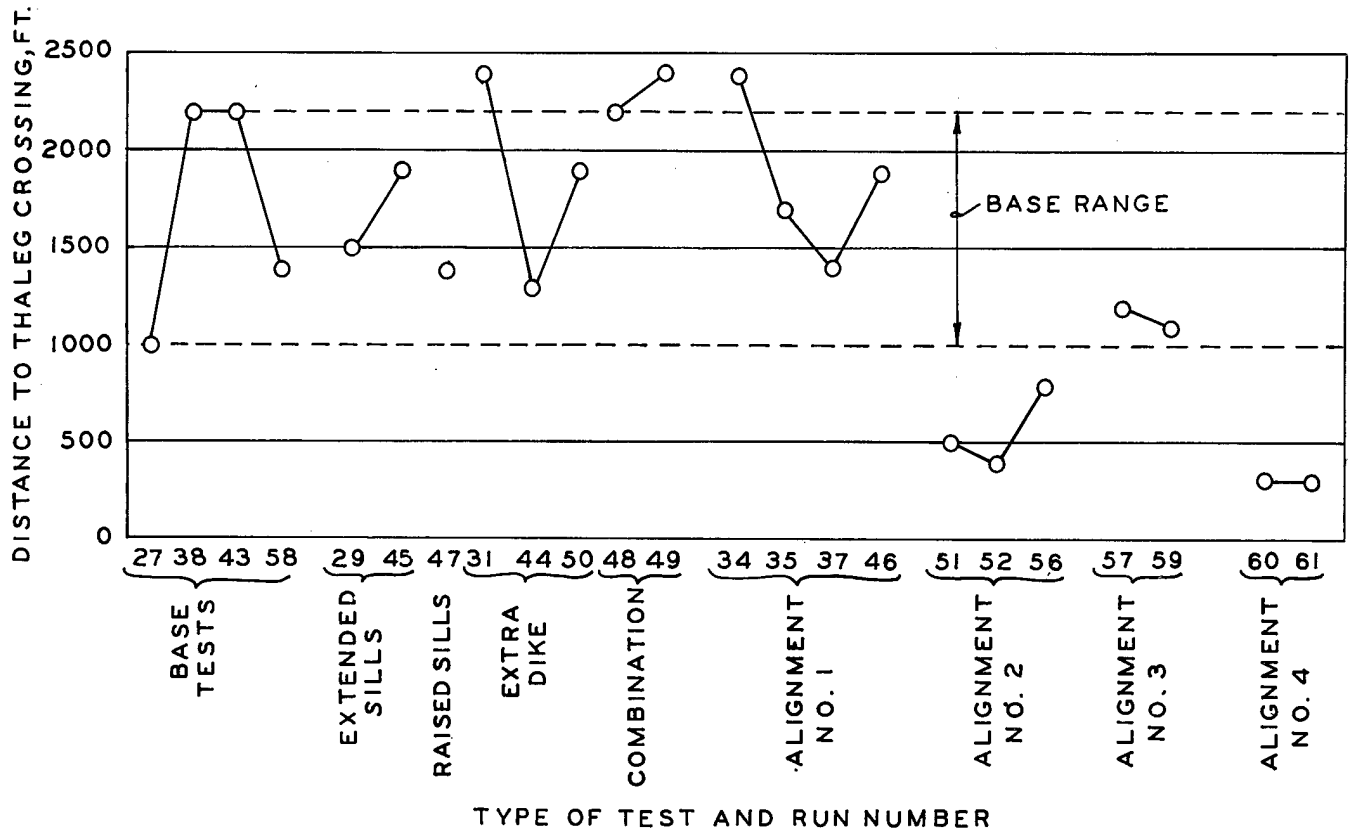

KEY

MEAD HYDRAULIC LABORATORY
BUSHWHACKER BEND
 THALWEG CROSSING LOCATIONS
 UPSTREAM FROM CROSSING STRUCTURE

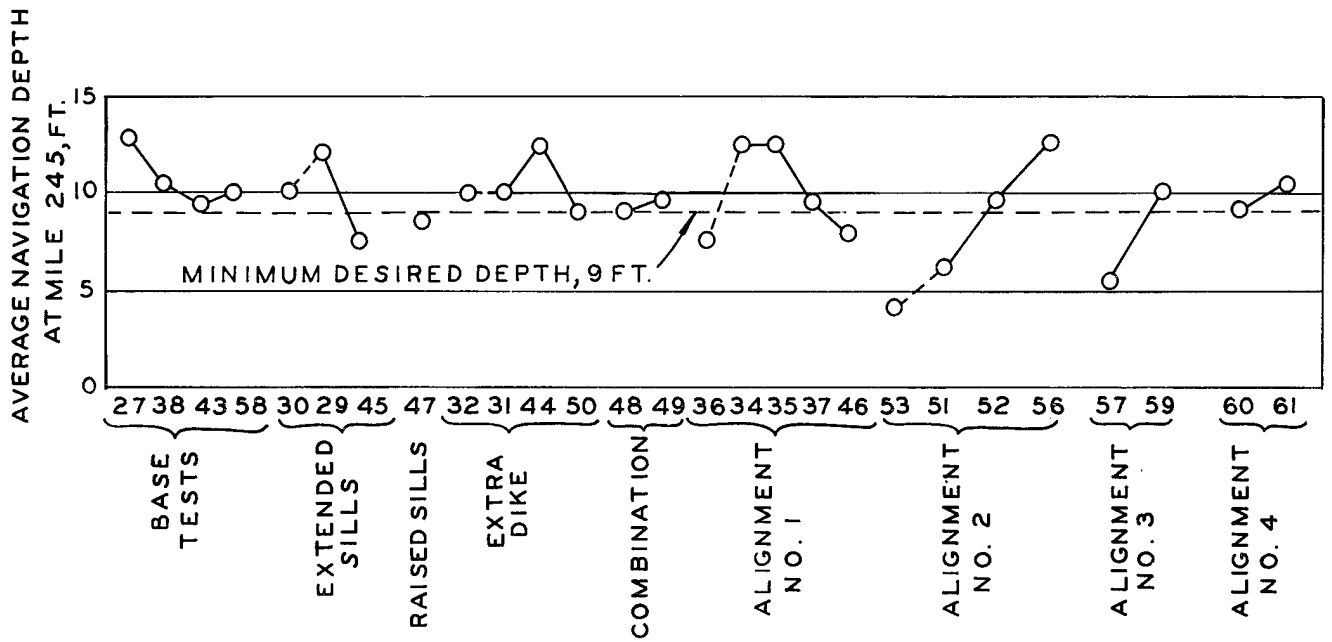

TYPE OF TEST AND RUN NUMBER

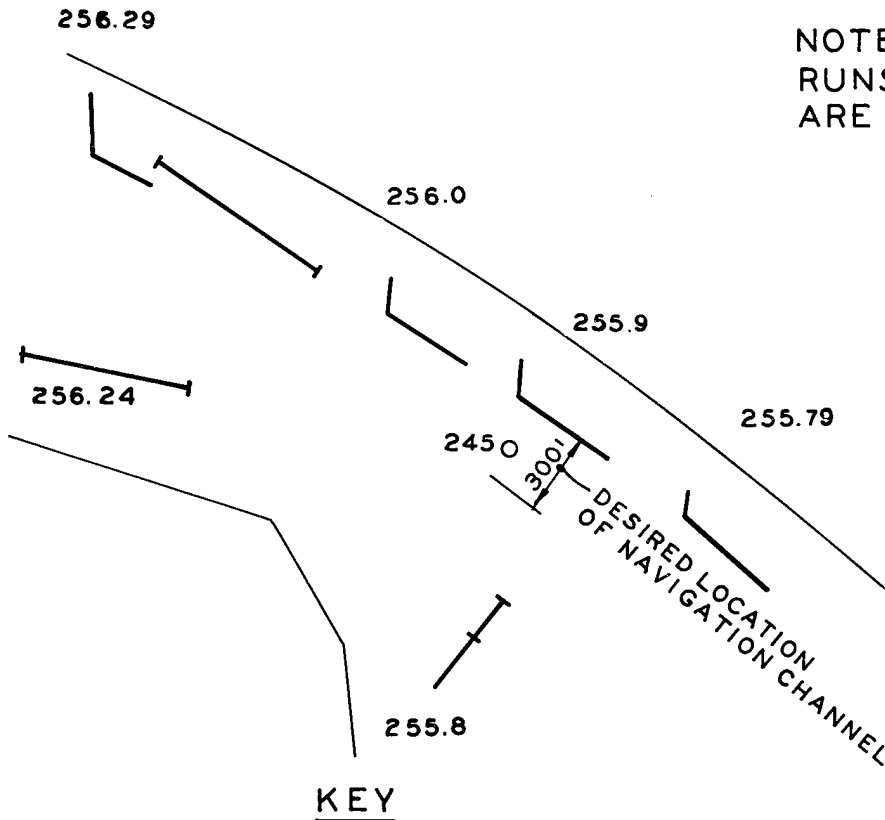

MEAD HYDRAULIC LABORATORY
BUSHWHACKER BEND
 AVERAGE NAVIGATION DEPTH
 AT RIVER MILE 245

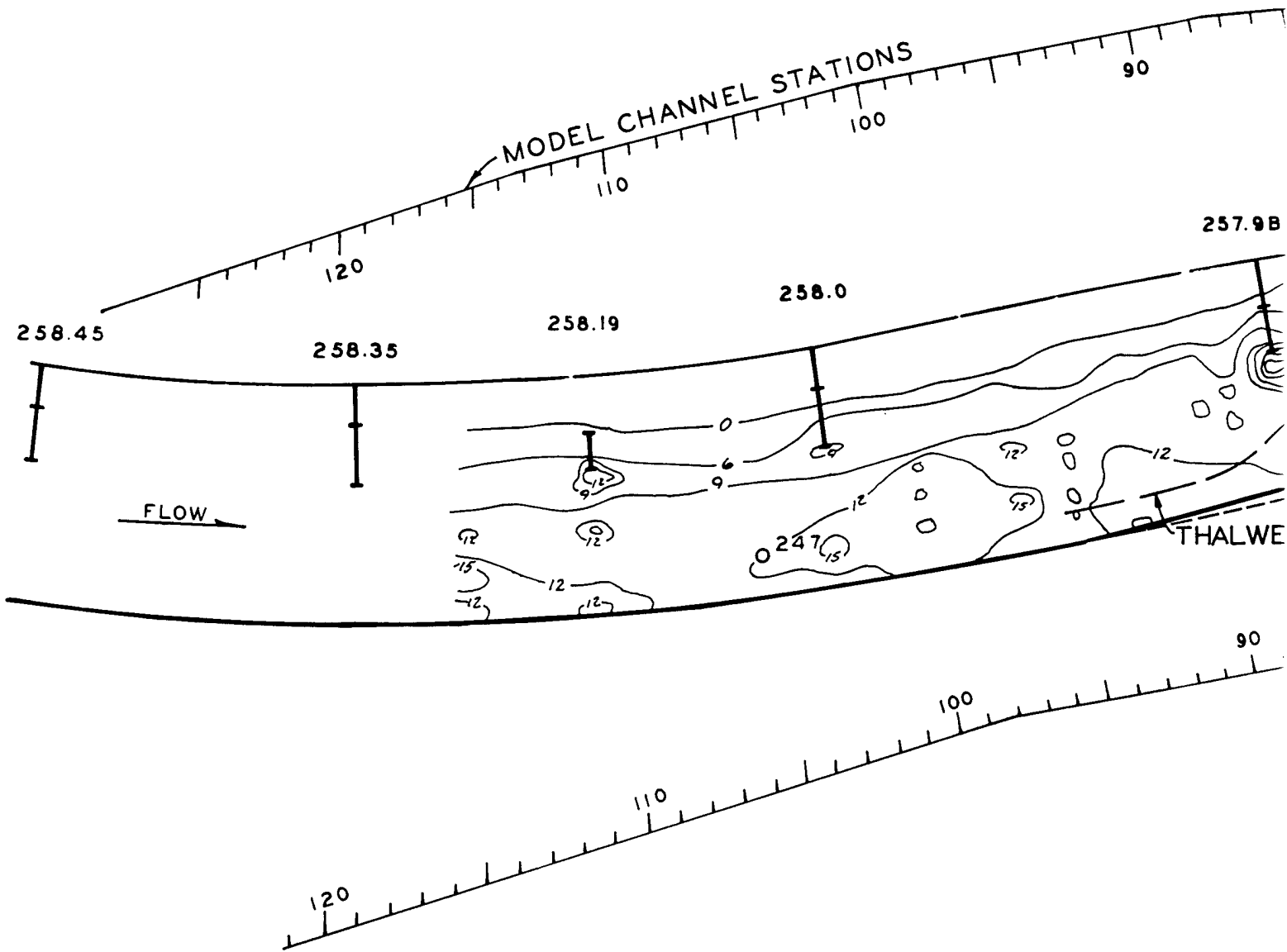

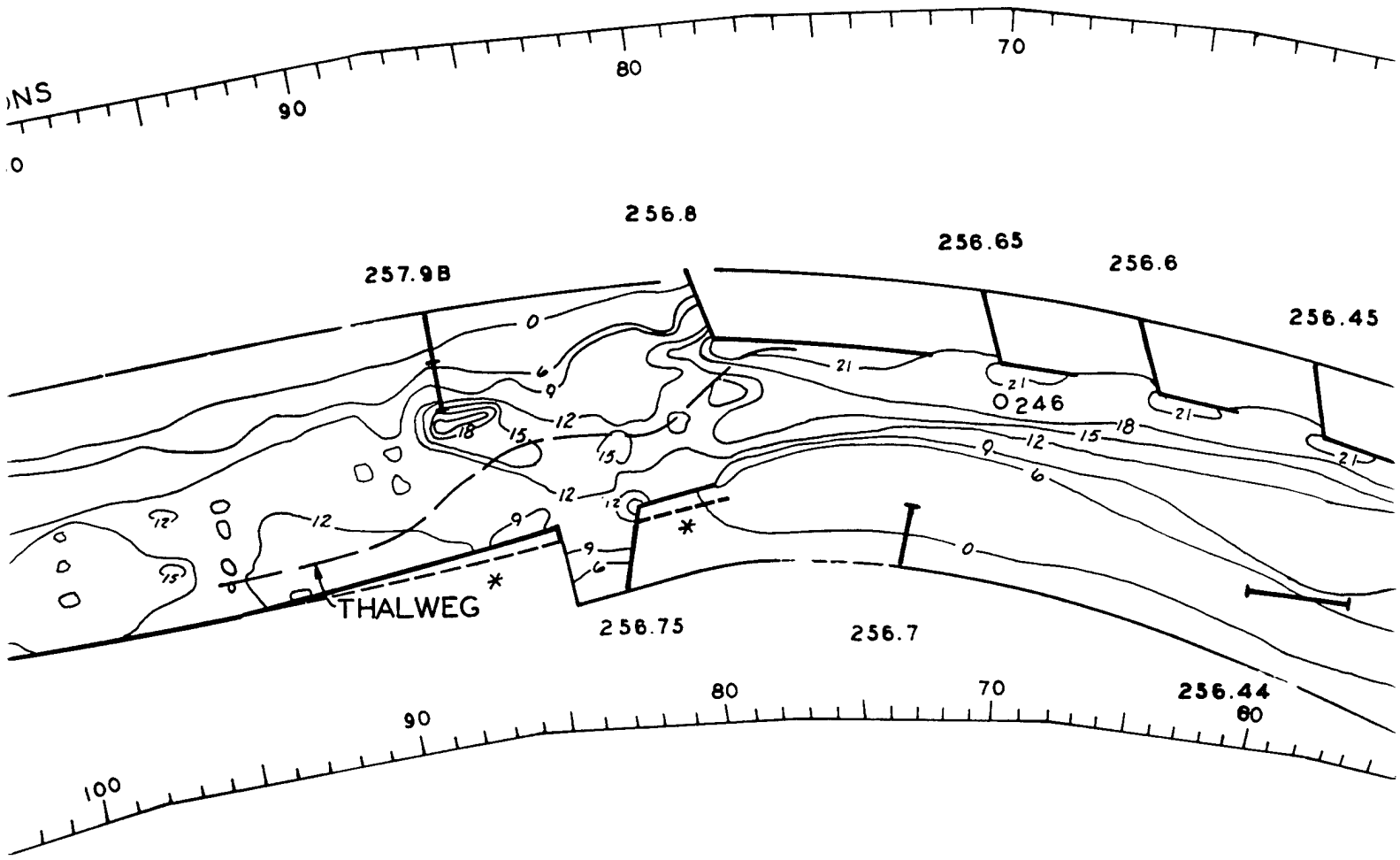

- NOTES:
 1. SEE
 2. *NE

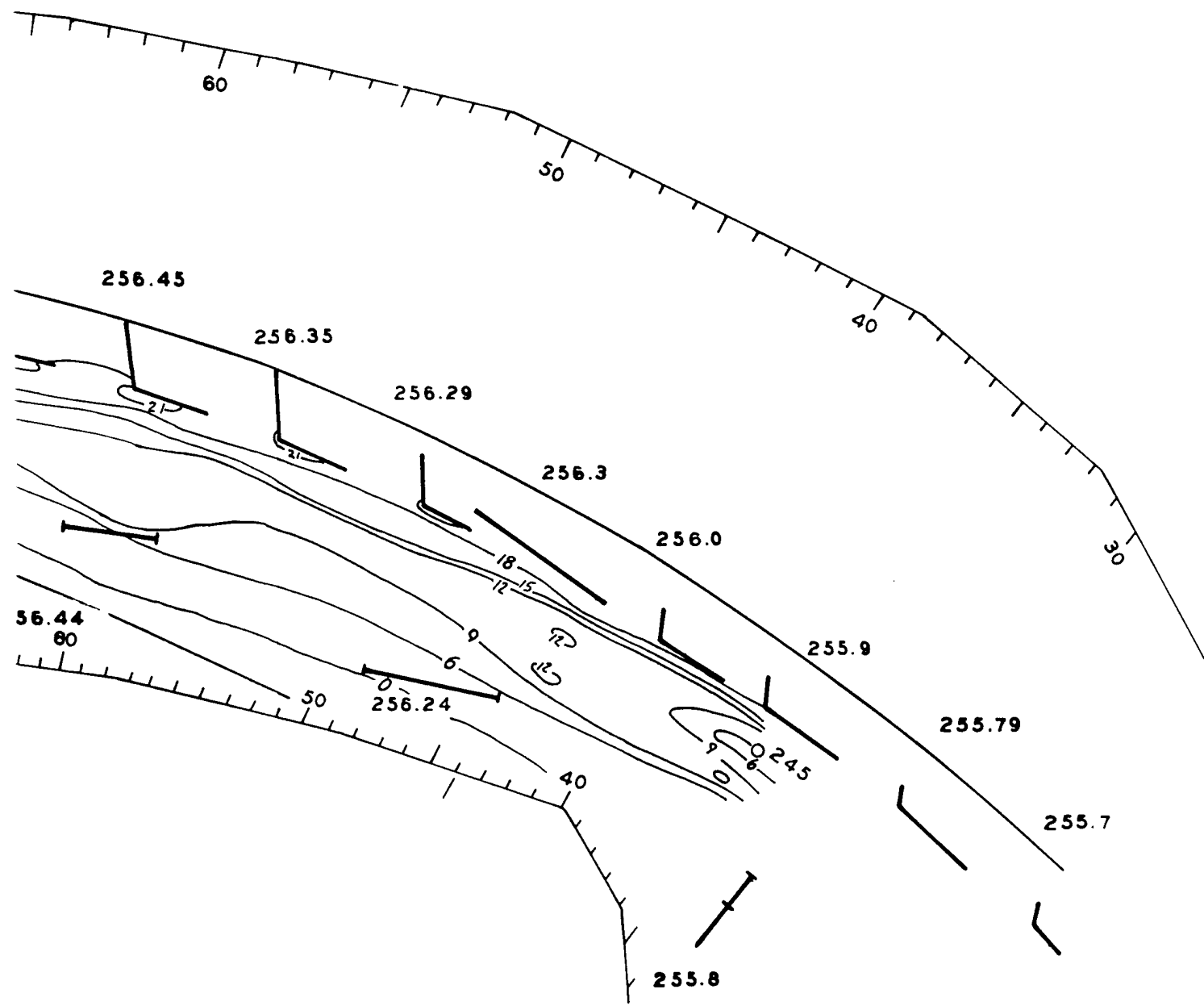

NOTES:

1. SEE PLATE 2 FOR NOTES.
2. *NEW OR MODIFIED STRUCTURE.

MEAD HYDRAULIC LABORATORY
BUSHWHACKER BEND
 ALIGNMENT NO. 1 WITH
 BED CONTOURS FROM RUN 46

3

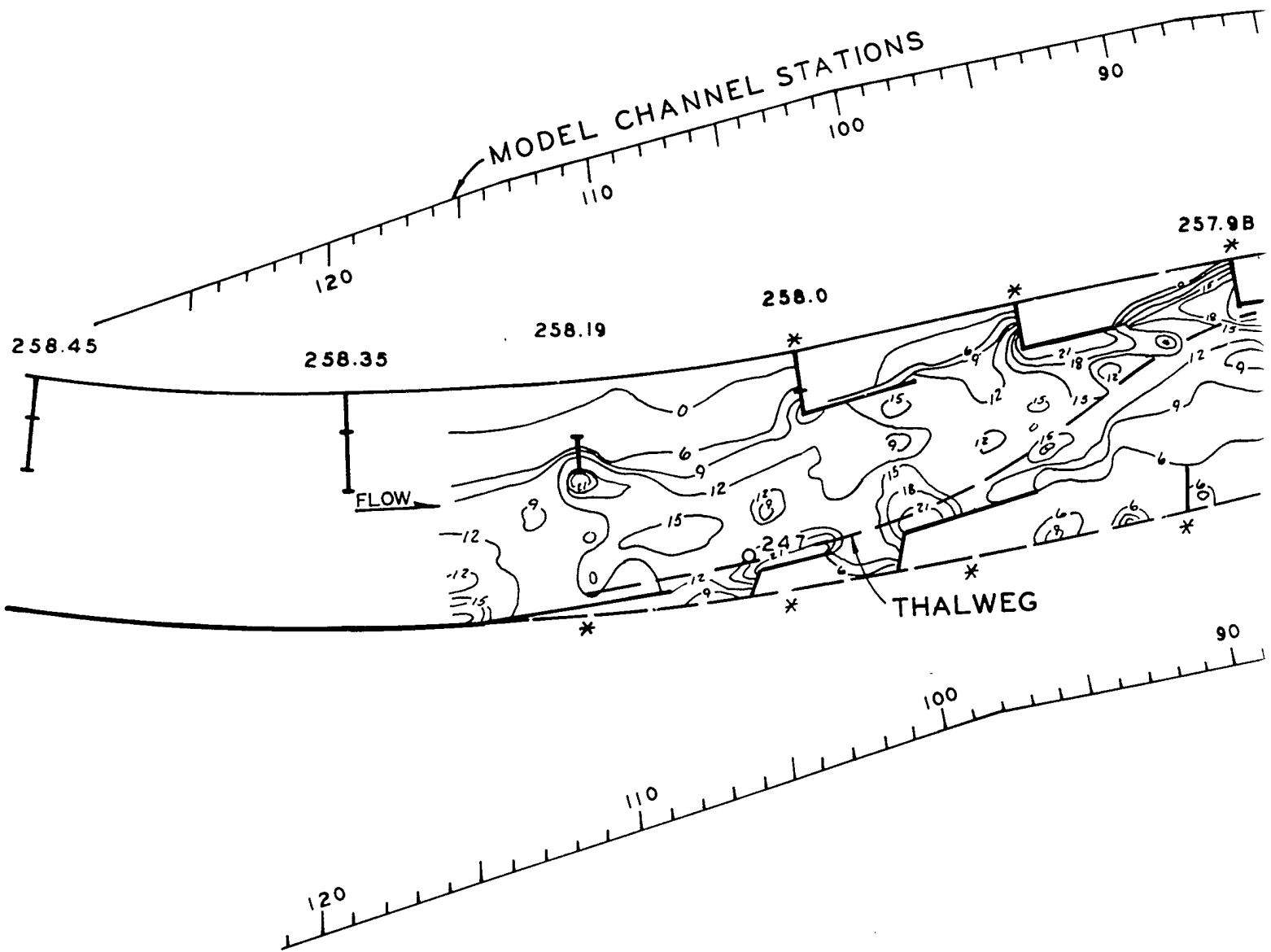

PROTOTYPE SCALE IN 100'

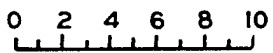

MODEL SCALE IN FEET

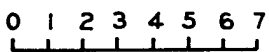

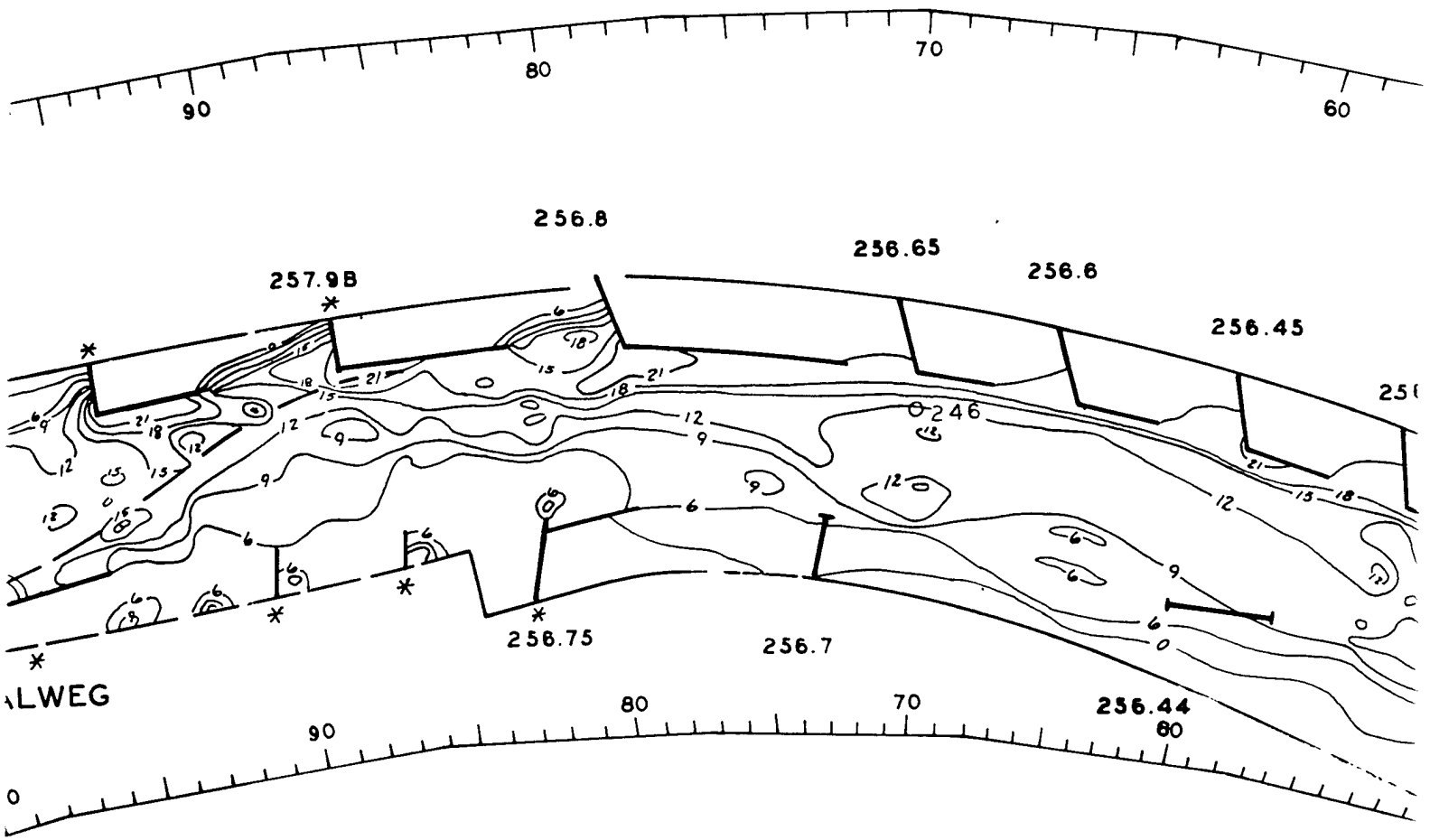

- NOTES:
1. SEE PLATE
 2. *NEW OR MO

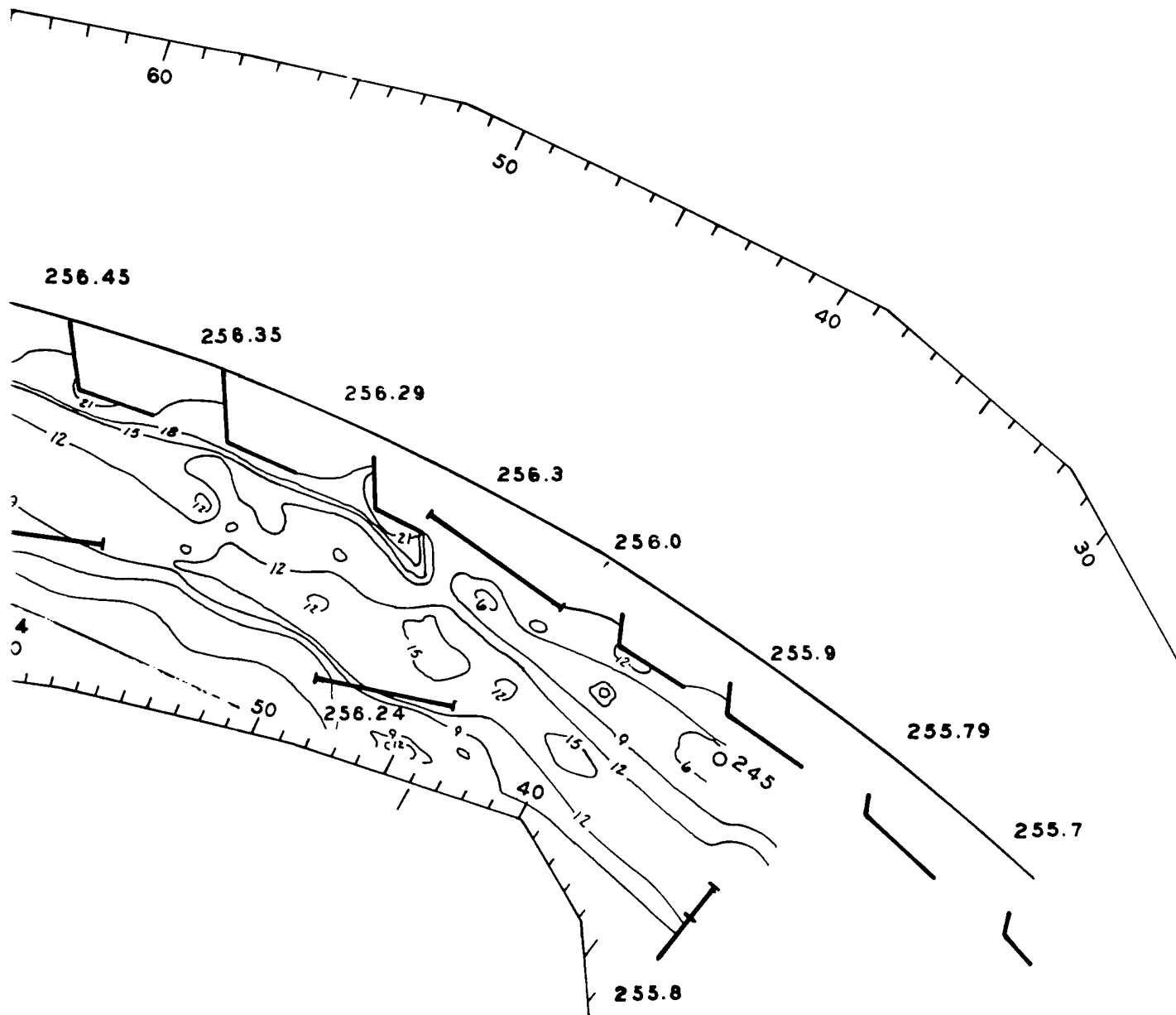

NOTES:

1. SEE PLATE 2 FOR NOTES.
2. *NEW OR MODIFIED STRUCTURE.

MEAD HYDRAULIC LABORATORY
BUSHWHACKER BEND
 ALIGNMENT NO. 2 WITH
 BED CONTOURS FROM RUN 51

3

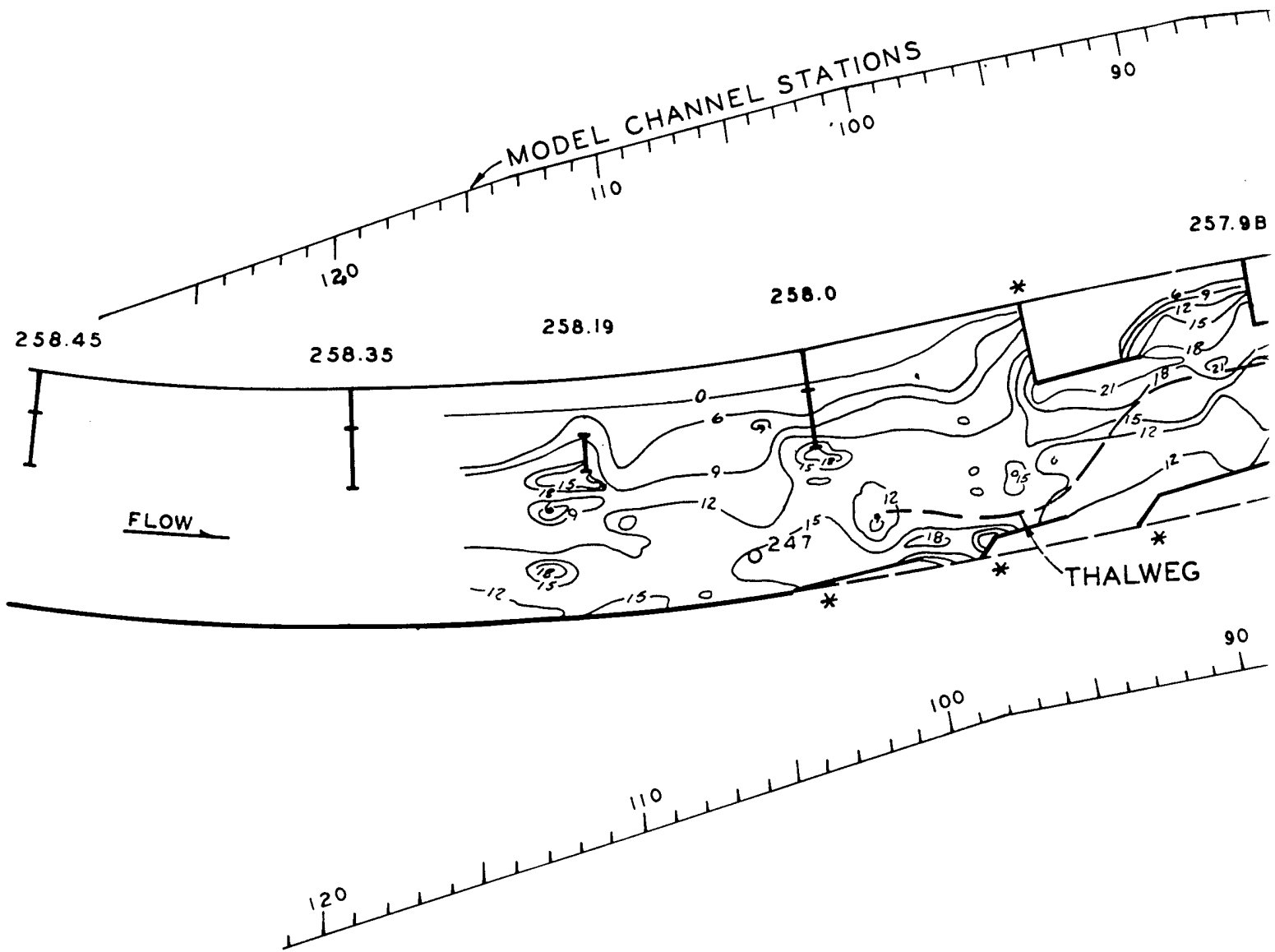

PROTOTYPE SCALE IN 100'

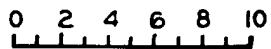

MODEL SCALE IN FEET

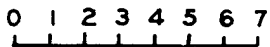

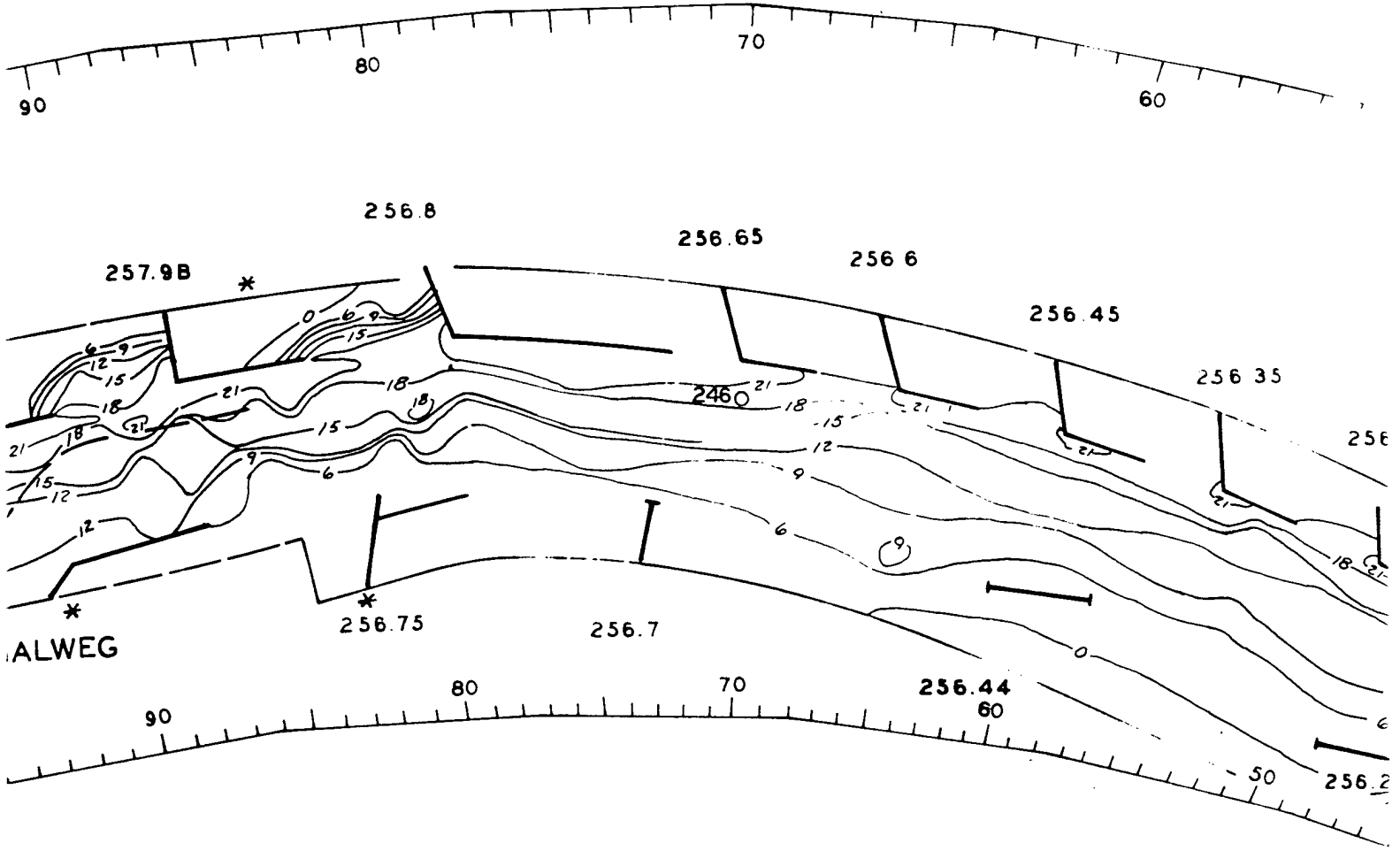

- NOTES:
1. SEE PLATE 2 FOR NOTES
 2. *NEW OR MODIFIED STRUC

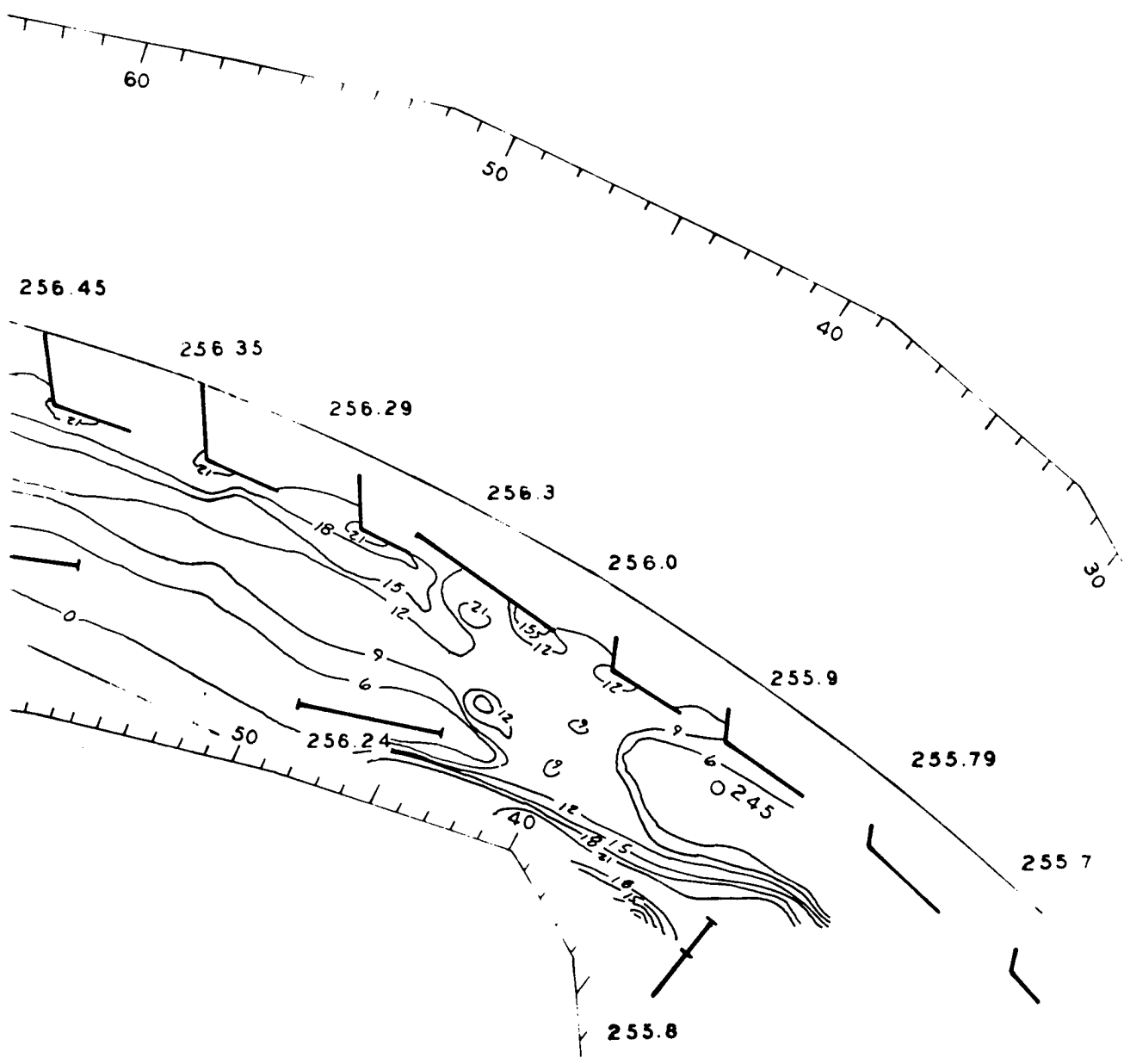

NOTES:

1. SEE PLATE 2 FOR NOTES.
2. *NEW OR MODIFIED STRUCTURE.

MEAD HYDRAULIC LABORATORY
BUSHWHACKER BEND
 ALIGNMENT NO. 3 WITH
 BED CONTOURS FROM RUN 57

3

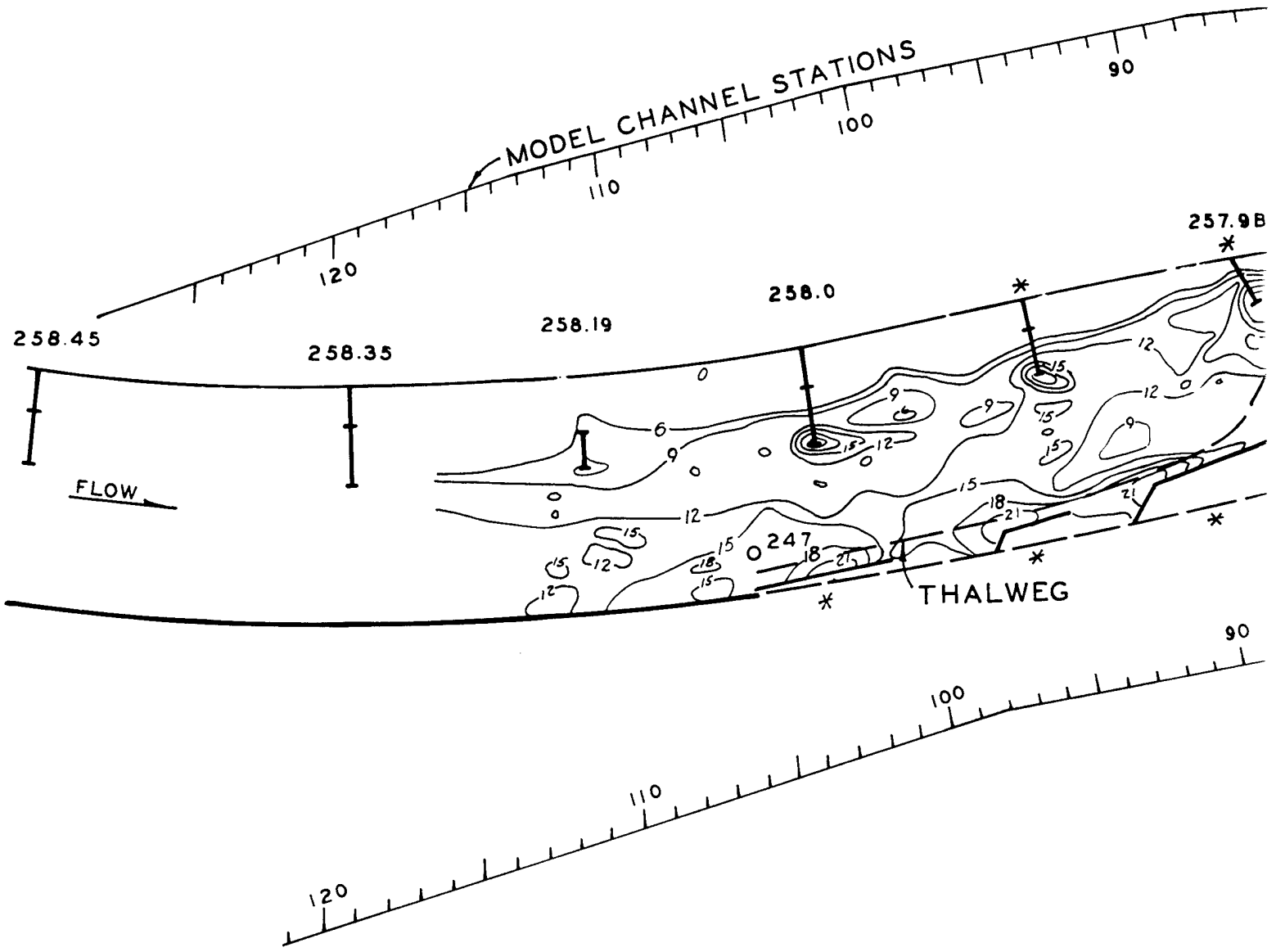

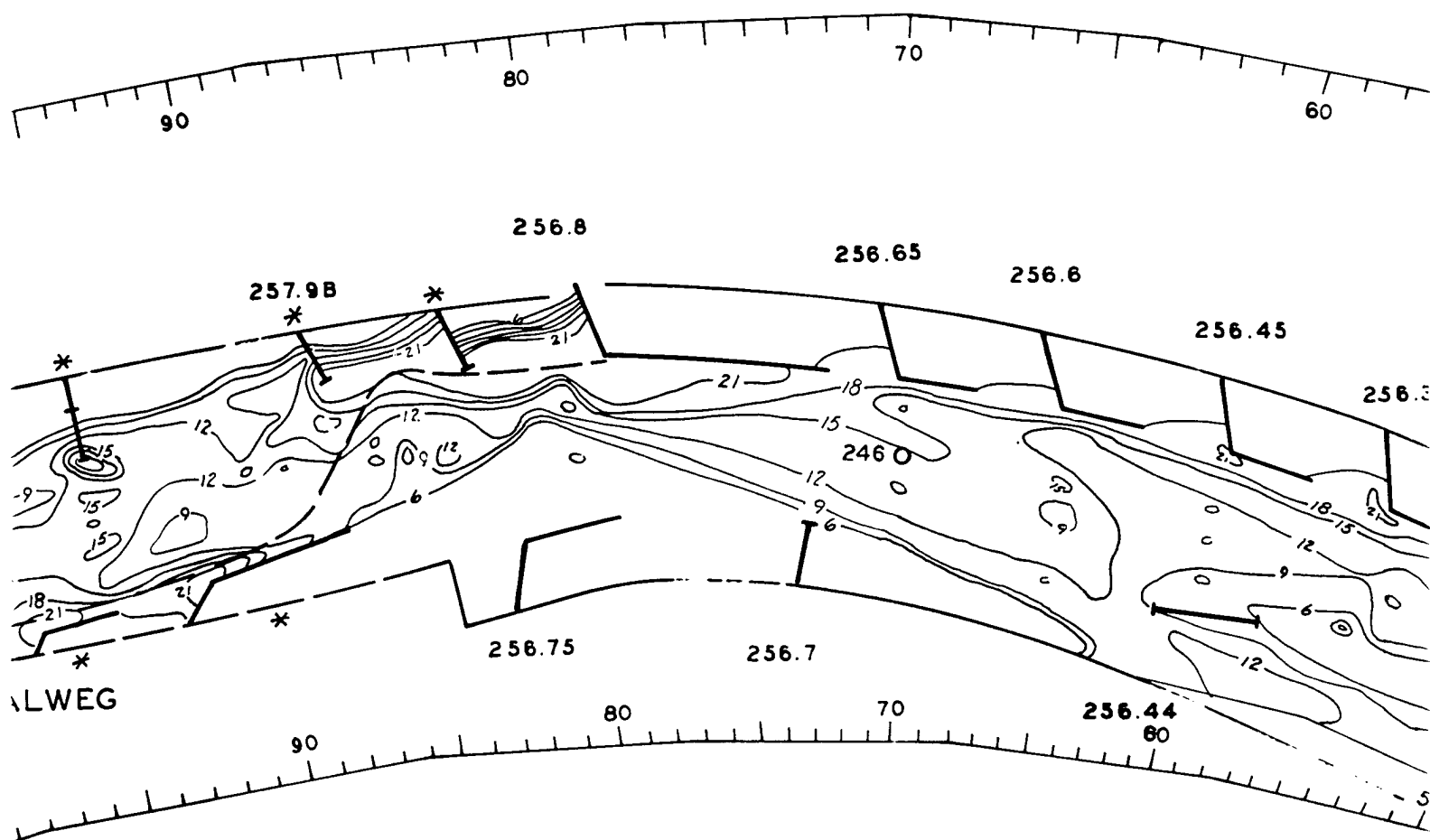

- NOTES:
1. SEE PLATE 2
 2. *NEW OR MODI

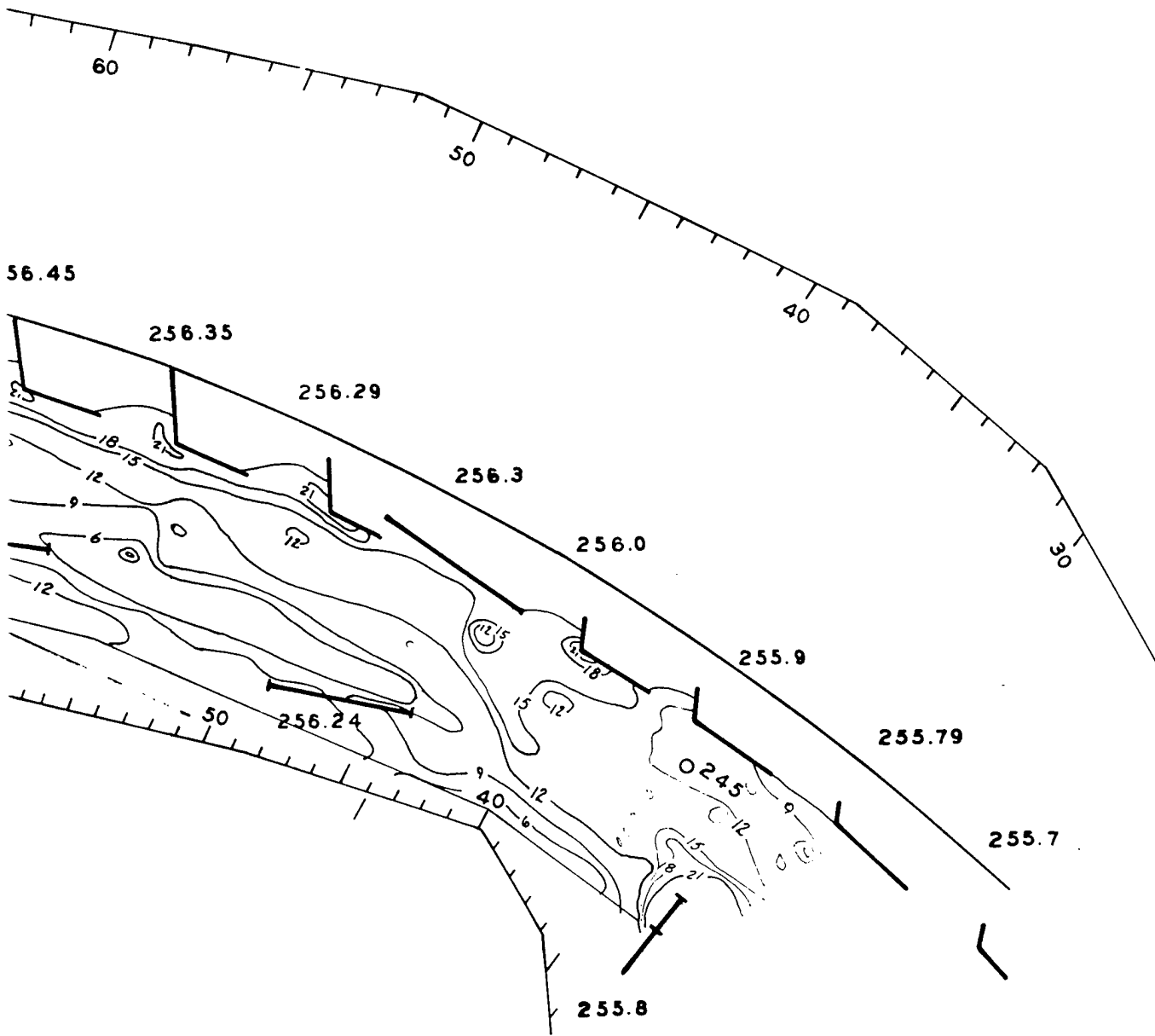

- NOTES:
1. SEE PLATE 2 FOR NOTES.
 2. *NEW OR MODIFIED STRUCTURE.

MEAD HYDRAULIC LABORATORY
BUSHWHACKER BEND
 ALIGNMENT NO. 4 WITH
 BED CONTOURS FROM RUN 60

3

APPENDIX D

PROTOTYPE FLOW DISTRIBUTIONS

APPENDIX D
 BUSHWACKER BEND AND GRAND RIVER BEND
 FLOW DISTRIBUTIONS
 VELOCITY MEASUREMENTS OBTAINED 13/05/81
 (Discharge, Q, from Waverly and
 Boonville Gages = 43,400 cfs)

Station	Depth	Velocity	Unit	Incremental	Station	Depth	Velocity	Unit	Incremental
FT	FT	FPS	Discharge	Discharge	FT	FT	FPS	Discharge	Discharge
	d	v	CFS/FT	CFS		d	v	CFS/FT	CFS
			q	Q				q	Q
LOCATION A RIVER MILE 247.40					LOCATION B RIVER MILE 246.92				
CONCAVE BANK					CONCAVE BANK				
950	18.5	4.80	-	-	880	15.9	3.53	-	-
850	16.5	4.60	82.2	8220	780	14.3	4.44	60.2	6020
750	15.5	4.76	74.9	7490	680	14.0	5.05	67.1	6710
650	9.0	4.40	56.1	5610	580	13.8	5.00	69.8	6980
550	9.2	4.08	38.6	3860	480	11.2	4.46	59.1	5910
450	9.5	4.32	39.3	3930	380	13.3	3.21	47.0	4700
350	13.0	4.11	47.4	4740					
CONVEX BANK					CONVEX BANK				
AVERAGE 12.6 4.48 56.4					AVERAGE 13.6 4.46 60.6				
Q' 33850					Q' 30320				
Q'/Q 0.78					Q'/Q 0.70				
LOCATION C RIVER MILE 246.48					LOCATION D RIVER MILE 246.25				
CONCAVE BANK					CONCAVE BANK				
850	16.3	3.89	-	-	140	13.6	4.06	-	-
750	14.5	4.36	63.5	6350	240	11.0	4.61	53.3	5330
650	12.1	4.70	60.2	6020	340	13.0	4.47	54.5	5450
550	8.4	5.20	50.7	5070	440	14.6	4.65	62.9	6290
450	10.0	4.72	45.6	4560	540	15.5	4.65	70.0	7000
350	9.8	4.61	46.2	4620	640	16.9	4.72	75.9	7590
250	18.2	3.28	55.2	5520					
CONVEX BANK					CONVEX BANK				
AVERAGE 12.0 4.47 53.6					AVERAGE 13.9 4.55 63.3				
Q' 32140					Q' 31660				
Q'/Q 0.74					Q'/Q 0.73				
LOCATION E RIVER MILE 245.85					LOCATION F RIVER MILE 245.25				
CONCAVE BANK					CONCAVE BANK				
90	26.2	4.42	-	-	90	21.0	4.37	-	-
140	21.0	4.30	102.9	5145	150	18.0	4.23	83.8	5028
240	17.7	4.22	82.4	8240	250	17.0	5.04	81.1	8110
340	13.8	3.80	63.2	6320	350	19.5	4.81	89.9	8990
440	9.5	3.40	41.9	4190	450	16.0	3.36	72.5	7250
540	7.5	2.68	25.8	2580	550	12.8	3.27	47.7	4770
CONVEX BANK					CONVEX BANK				
AVERAGE 14.9 3.95 58.8					AVERAGE 16.2 4.07 66.0				
Q' 26475					Q' 36968				
Q'/Q 0.61					Q'/Q 0.85				