

**EROSION CONTROL DEMONSTRATION  
PROJECTS STUDY  
(P. L. 93-251 SECTION 32)**

**MRD HYDRAULIC LABORATORY SERIES  
REPORT NO. 9**

**LABORATORY INVESTIGATION OF  
EROSION CONTROL USING HARD POINTS**

**MEAD HYDRAULIC LABORATORY  
MEAD, NEBRASKA**

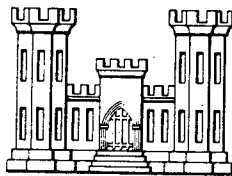

**U. S. ARMY ENGINEER DISTRICT, OMAHA  
MISSOURI RIVER DIVISION, OMAHA  
NOVEMBER 1977**

**DISTRIBUTION STATEMENT A  
Approved for Public Release  
Distribution Unlimited**

19990525 051

# REPORT DOCUMENTATION PAGE

Form Approved  
OMB No. 0704-0188

Public reporting burden for this collection of information is estimated to average 1 hour per response, including the time for reviewing instructions, searching existing data sources, gathering and maintaining the data needed, and completing and reviewing the collection of information. Send comments regarding this burden estimate or any other aspect of this collection of information, including suggestions for reducing this burden, to Washington Headquarters Services, Directorate for Information Operations and Reports, 1215 Jefferson Davis Highway, Suite 1204, Arlington, VA 22202-4302, and to the Office of Management and Budget, Paperwork Reduction Project (0704-0188), Washington, DC 20503.

|   |                                 |   |  |
|---|---------------------------------|---|--|
| 1. AGENCY USE ONLY (Leave blank)  | 2. REPORT DATE<br>November 1977 | 3. REPORT TYPE AND DATES COVERED  |  |
| 4. TITLE AND SUBTITLE<br>Laboratory Investigation of Erosion Control Using Hard Points  |                                 | 5. FUNDING NUMBERS<br>P.L. 93-251<br>Section 32<br>WU 3   |  |
| 6. AUTHOR(S)  |                                 | 7. PERFORMING ORGANIZATION NAME(S) AND ADDRESS(ES)<br>Mead Hydraulic Laboratory<br>Mead, Nebraska                                   |  |
| 8. PERFORMING ORGANIZATION REPORT NUMBER  |                                 | 9. SPONSORING/MONITORING AGENCY NAME(S) AND ADDRESS(ES)<br>Omaha District, Corps of Engineers<br>215 N. 17th St.<br>Omaha, NE 68102 |  |
| 10. SPONSORING/MONITORING AGENCY REPORT NUMBER<br>MRD Hydraulic Laboratory Series Report #9   |                                 | 11. SUPPLEMENTARY NOTES<br>Missouri River Division  |  |
| 12a. DISTRIBUTION/AVAILABILITY STATEMENT<br>This report has been approved for public release and sale; its distribution is unlimited.   |                                 | 12b. DISTRIBUTION CODE  |  |
| 13. ABSTRACT (Maximum 200 words)<br>This is the second in a series of reports on short duration model studies conducted at the Mead Hydraulics Laboratory under the authority of P.L. 93-251, section 32, Work Unit 3. The first report was Mead Laboratory Series Report number 8, Preliminary Laboratory Investigation of section 32 Hard Point structures.<br>The object of these model studies is to investigate the use and applicability of erosion control structures associated with the control and maintenance of river banks for the purpose of finding the most economical, effective, and environmentally acceptable solution. This particular study was initiated to find and identify information that would aid in our design methods. The study investigated hard point structures in S-shaped basin alignment under uniform flow and constant slope conditions. |                                 |   |  |
| 14. SUBJECT TERMS<br>erosion control structures<br>river banks  |                                 | 15. NUMBER OF PAGES<br>18   |  |
| 16. PRICE CODE  |                                 | 17. SECURITY CLASSIFICATION OF REPORT<br>Unclassified   |  |
| 18. SECURITY CLASSIFICATION OF THIS PAGE<br>Unclassified  |                                 | 19. SECURITY CLASSIFICATION OF ABSTRACT<br>Unclassified   |  |
| 20. LIMITATION OF ABSTRACT  |                                 |   |  |

## GENERAL INSTRUCTIONS FOR COMPLETING SF 298

The Report Documentation Page (RDP) is used in announcing and cataloging reports. It is important that this information be consistent with the rest of the report, particularly the cover and title page. Instructions for filling in each block of the form follow. It is important to *stay within the lines* to meet *optical scanning requirements*.

**Block 1. Agency Use Only (Leave blank).**

**Block 2. Report Date.** Full publication date including day, month, and year, if available (e.g. 1 Jan 88). Must cite at least the year.

**Block 3. Type of Report and Dates Covered.** State whether report is interim, final, etc. If applicable, enter inclusive report dates (e.g. 10 Jun 87 - 30 Jun 88).

**Block 4. Title and Subtitle.** A title is taken from the part of the report that provides the most meaningful and complete information. When a report is prepared in more than one volume, repeat the primary title, add volume number, and include subtitle for the specific volume. On classified documents enter the title classification in parentheses.

**Block 5. Funding Numbers.** To include contract and grant numbers; may include program element number(s), project number(s), task number(s), and work unit number(s). Use the following labels:

|                      |                              |
|----------------------|------------------------------|
| C - Contract         | PR - Project                 |
| G - Grant            | TA - Task                    |
| PE - Program Element | WU - Work Unit Accession No. |

**Block 6. Author(s).** Name(s) of person(s) responsible for writing the report, performing the research, or credited with the content of the report. If editor or compiler, this should follow the name(s).

**Block 7. Performing Organization Name(s) and Address(es).** Self-explanatory.

**Block 8. Performing Organization Report Number.** Enter the unique alphanumeric report number(s) assigned by the organization performing the report.

**Block 9. Sponsoring/Monitoring Agency Name(s) and Address(es).** Self-explanatory.

**Block 10. Sponsoring/Monitoring Agency Report Number.** (If known)

**Block 11. Supplementary Notes.** Enter information not included elsewhere such as: Prepared in cooperation with...; Trans. of...; To be published in.... When a report is revised, include a statement whether the new report supersedes or supplements the older report.

**Block 12a. Distribution/Availability Statement.** Denotes public availability or limitations. Cite any availability to the public. Enter additional limitations or special markings in all capitals (e.g. NOFORN, REL, ITAR).

DOD - See DoDD 5230.24, "Distribution Statements on Technical Documents."

DOE - See authorities.

NASA - See Handbook NHB 2200.2.

NTIS - Leave blank.

**Block 12b. Distribution Code.**

DOD - Leave blank.

DOE - Enter DOE distribution categories from the Standard Distribution for Unclassified Scientific and Technical Reports.

NASA - Leave blank.

NTIS - Leave blank.

**Block 13. Abstract.** Include a brief (*Maximum 200 words*) factual summary of the most significant information contained in the report.

**Block 14. Subject Terms.** Keywords or phrases identifying major subjects in the report.

**Block 15. Number of Pages.** Enter the total number of pages.

**Block 16. Price Code.** Enter appropriate price code (*NTIS only*).

**Blocks 17. - 19. Security Classifications.** Self-explanatory. Enter U.S. Security Classification in accordance with U.S. Security Regulations (i.e., UNCLASSIFIED). If form contains classified information, stamp classification on the top and bottom of the page.

**Block 20. Limitation of Abstract.** This block must be completed to assign a limitation to the abstract. Enter either UL (unlimited) or SAR (same as report). An entry in this block is necessary if the abstract is to be limited. If blank, the abstract is assumed to be unlimited.

Department of the Army  
Corps of Engineers

Laboratory Investigation of Erosion  
Control Using Hard Points

Conducted at  
Mead Hydraulic Laboratory  
Mead, Nebraska

U.S. Army Engineer District, Omaha District  
Missouri River Division, Omaha, Nebraska

November 1977

## Table of Contents

|                          | Page |
|--------------------------|------|
| I Introduction           | 1    |
| II Purpose of Study      | 1    |
| III Model Setup          | 2    |
| IV Procedure for Testing | 4    |
| V Data Accumulation      | 7    |
| VI Study Analysis        | 8    |
| VII Conclusions          | 17   |
| VIII Appendix Plates     |      |

### List of Pictures

Picture  
Number

- 1 Basin layout for the test study
- 2 Formation of the test bank
- 3 The slope control device
- 4 Marking the horizontal reference lines
- 5 Excavation of the root trench
- 6 Placement of the hard point
- 7 Failure of hard points in a curve alignment
- 8 Failure of hard points in a straight alignment
- 9 Root alignment perpendicular to the channel
- 10 Root alignment at  $30^{\circ}$  angle to the channel
- 11 Root alignment at  $60^{\circ}$  angle to the channel

### List of Plates

Plate  
Number

- 1 Laboratory basin layout
- 2 Mechanical gradation of rock revetment
- 3 Graph showing lateral erosion relationship to spacing
- 4 Typical test measurements
- 5 Graph showing lateral erosion relationship to Froude number and spacing
- 6 Graph showing the angle of erosion expansion versus the average velocity of the reach

## Introduction

This is the second in a series of reports on short duration model studies conducted at the Mead Hydraulics Laboratory under the authority of P.L. 93-251, Section 32, Work Unit 3. The first report was Mead Laboratory Series: Report Number 8, Preliminary Laboratory Investigation of Section 32 Hard Point Structures.

The object of these model studies is to investigate the use and applicability of erosion control structures associated with the control and maintenance of river banks for the purpose of finding the most economical, effective, and environmentally acceptable solution. This particular study was initiated to find and identify information that would aid in our design methods. The study investigated hard point structures in S-shaped basin alignment under uniform flow and constant slope conditions.

The specific objectives of the study were to determined:

1. The recommended design for hard point structures to protect against failure.
2. The effect of flows overtopping the structure.
3. Whether the structures were equally effective in curved and straight channel reaches.
4. The effect of structure alignment on the erosion pattern.
5. The effects of varied spacing on the erosion pattern.
6. The effect of velocity and depth on the erosion pattern.

This study was performed by the personnel of the Mead Hydraulics Laboratory under the direct supervision of the Channel Stabilization and Hydraulics Sections of the Omaha District and under the general supervision of the Missouri River Division.

## Purpose of Study

There is great concern for the control of bank erosion and for the proper methods of achieving this control along the uncontrolled reaches of the Missouri River and other alluvial rivers. The Corps of Engineers' objective is to save and protect lands adjacent to the river without adversely affecting the existing natural environmental riverine qualities.

One method of erosion control used in reaches of relatively straight alignment is the installation of rock hard point structures. Rock hard points are two-part structures consisting of a nose and a root. The rock nose is placed directly on the channel bank to stop streamflow erosion at that point. The rock root ties the nose into the bank to prevent the structure from being outflanked by upstream bank erosion and during flood

stage discharges. The design quantity of rock used on the nose and root may vary depending on the erosion condition.

Investigated in this study is the placement of hard point structure for the most economical and environmentally compatible protection method of preventing excessive bank erosion. Basic criteria for the placement, dimensions, spacing, and alignment for hard point structures and the erosion pattern created by their existence is limited. Our proposal for this study was to observe the behavior of various hard point structures placed on erodible channel banks to determine the effectiveness of the hard points as well as the nature of the resulting erosion patterns. To accomplish this, several structures were set along the reach at equal intervals and observations were made on the erosion pattern that developed after each test period. Initially, both the straight and curved alignments in the basin were utilized. As the study progressed, however, only a straight channel reach alignment was used.

#### Model Setup

The basin area used for this study was designed to fit in a previously constructed flume, 120 feet long and 22 feet wide. The flume consists of a movable bed of walnut shells in a closed, recirculatory system. The walnut shells are ground and sieved to closely approximate the gradation of the Missouri River sand. The system is further described in MRD Hydraulic Laboratory Series: Report No. 1.

For this particular study there was no particular prototype region to be modeled. Model dimensions and criteria used from previous model studies on regions of the Missouri River were used as the basis for setting up this study.

The model test channel was a straight reach alignment about 40 feet long between two curves with different radii of curvature. The basin used is shown in picture 1 and plate 1. The upstream approach and downstream exit portions of the test reach were controlled regions lined with permanent revetment. The stream bank opposite the erodible test bank was also permanently revetted to maintain a uniform flow depth. Erosion could only take place in the channel bed or along the test bank of the model.

The basic channel shape was designed to be trapezoidal with 5 ft. maximum top width and side slopes of 1.5H to 1V. The average depth was 0.25 feet, typical of previous Missouri River model studies. The channel bank along the test reach was formed before each test with a male template. The template carriage was traversed along the channel on a system of rails. Only the right bank of the 40 foot straight reach had to be reformed before each test. The channel shaping procedure is shown in picture 2.

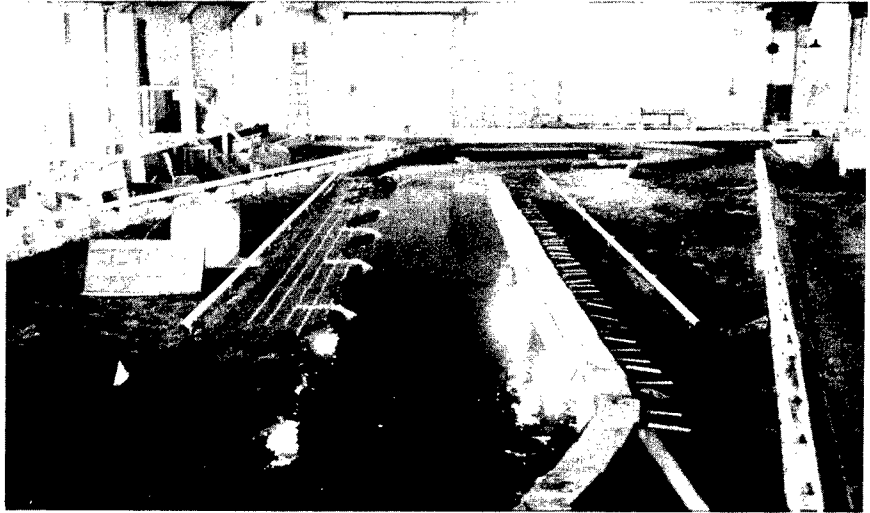

Picture 1: General upstream view of the basin flume after a typical test.

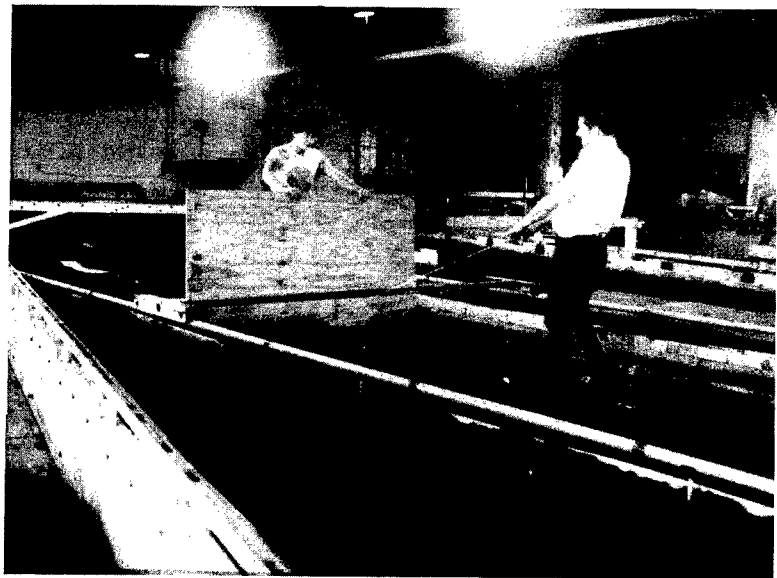

Picture 2: Formation of the test bank using a male template fixed to a carriage on a rail traverse.

### Procedure for Testing

Model tests were conducted to find the extent of bank erosion that occurred in a test reach for different hard point structure spacing.

The tests were conducted with fixed control parameters. Each test was made with a constant discharge and water surface gradient. It was determined from previous studies that discharges averaging around 0.40 to 1.00 c.f.s. would provide sufficient flow for bed movement and erosion to a depth of approximately 0.25 feet. The gradient was held constant using a recently installed instrument called a "slope control device". The instrument monitors water surface elevations at established upstream and downstream control stations through a system of impact tubes and stilling wells. It can be set to maintain a desired differential between these two stations. The device adjusts the volume of water in the basin to provide and maintain the desired gradient. Adjustments in the channel bed occur automatically with changes in the slope and discharge. The slope is determined by dividing the difference between the upstream and downstream elevation by the channel length between the controls. The slope control device is shown in picture 3.

Typical model tests lasted approximately 24 hours. The test usually began in late afternoon and continued through the night and the next morning. The morning period was used for data accumulation. By noon, the test was usually completed and the remaining data were accumulated. The channel could then be made ready again in a few hours for a new test.

The channel was reformed prior to the start of each test run. The bank material lost after each test was replaced with wet bed material and shaped back to provide a uniform configuration by pulling a male template through the material. Horizontal lines, spaced 0.4 foot apart along the test zone, were formed by placing thin deposits of previously unused light colored walnut shells. The lines were used as a horizontal reference for evaluation of the erosion pattern. The marking process is shown in picture 4.

After the channel bank was reformed, the selected hard point spacing interval was measured off and prepared for rock placement. Hard point structures require two types of rock placement, the root and the nose. A rectangular root trench was cut into the bank lines with the dimensions dictated by the preselected quantity of rock to be used. The trench was cut about a foot back and 0.2 foot deep and 0.4 foot wide. The trench was then filled with the specified quantity of rock per foot. The rock nose was formed by dumping the rock directly onto the channel bank and tied into the rock root. The process is shown in pictures 5 and 6. The gradation for the rock used in modeling the hard point structure was scaled down from the rock gradation currently being specified for hard points on the Missouri River. The gradation comparison is shown on plate 2.

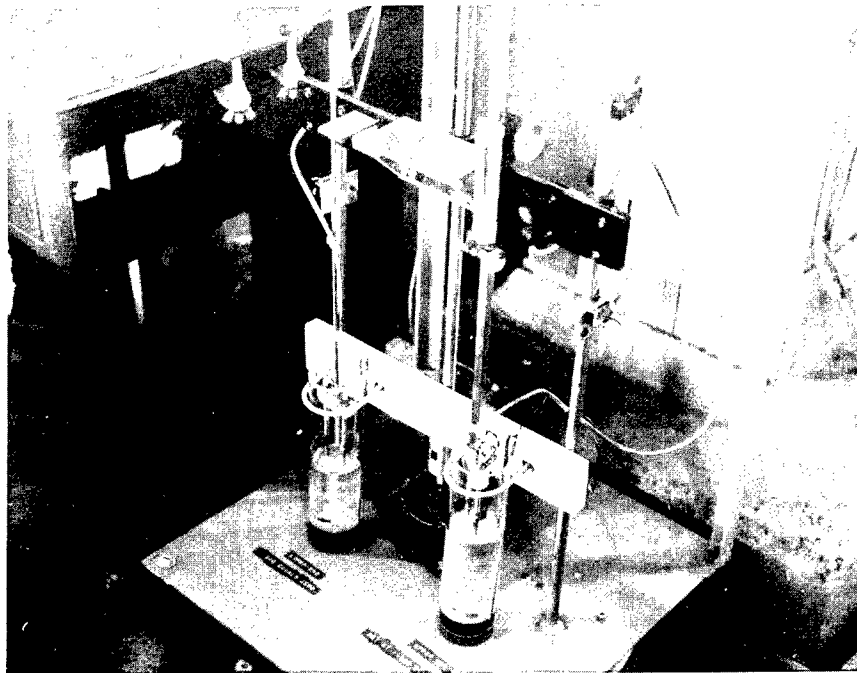

Picture 3: A view of the slope control device showing the stilling wells and electronic monitoring components

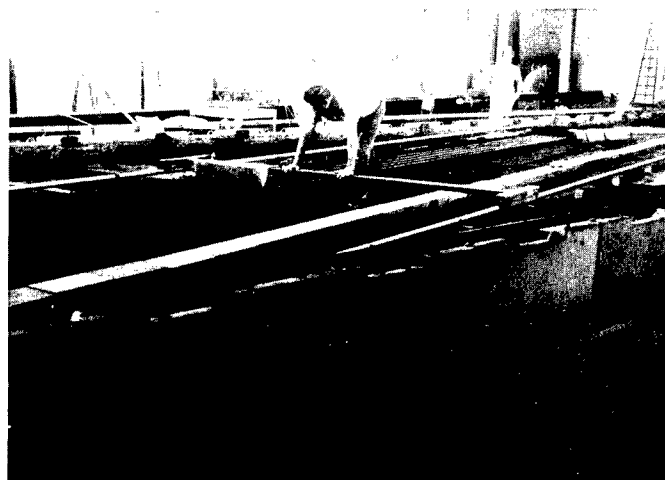

Picture 4. Marking procedure for the horizontal reference lines on the test bank.

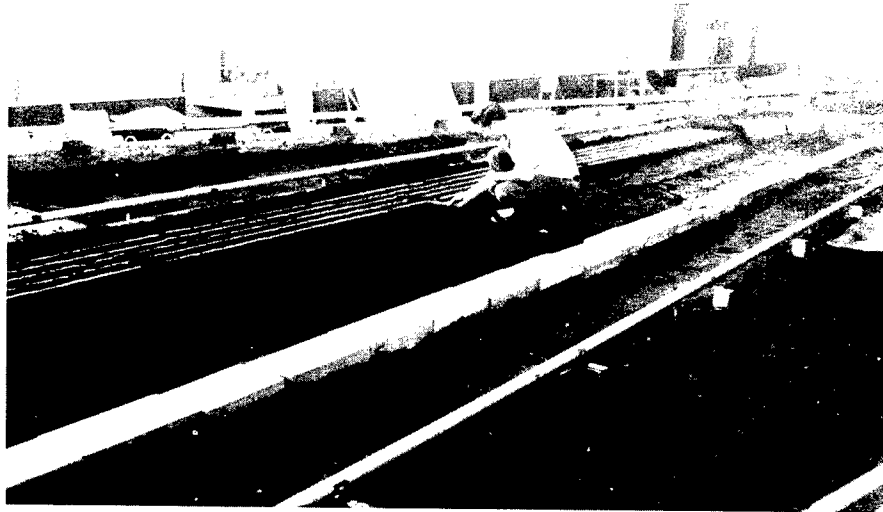

Picture 5: Excavation of the root trench into the right bank.



Picture 6: Placement of the rock used for the hard point structure formation.

After the rock placement, the basin was filled slowly to inhibit bank sloughing and the test run was started. Each run was made at a predetermined discharge, slope, and spacing interval. The channel flow velocity and depth were allowed to develop subject to the constraints imposed by preselected parameters. The model normally reached equilibrium conditions after about 8 hours of running. The maximum extent of erosion usually occurred after about 10 hours of running. After completion of the model test, usually after about 24 hours, the channel was drained and the remaining data were accumulated.

#### Data Accumulation

During the 24-hour duration of each run, data accumulation was as follows:

1. At the beginning of the test, photographs were taken of the initial model setup from positions directly above the basin. All pictures for each of the tests were taken from the same overhead location and height so that the photographic scale would be constant. These pictures were used to show the bank areas before erosion.

2. In the morning after the erosion process had reached an apparent equilibrium condition, point velocity readings were taken at a control section. The location of the control section is shown on plate 1. The data obtained was used for a check on the selected control parameters.

3. Next, point velocities were obtained at 1-foot intervals across the channel at each structure. These point velocities were used to obtain the average depth and velocity for the section. This data was then used to obtain the respective averages for the test zone.

4. At the end of the run, photographs were taken of the final bank erosion pattern with water flowing past the structures. These photos included a series of time exposures showing the typical channel streamflow lines and eddy action around the hard points. White beads scattered throughout the channel reach were used to accent the flow pattern in the channel. The timed exposure was taken for a period of 2 seconds. The beads showed up in the photos as white streaks depicting the direction of the streamline flows in the channel. These photos were used for erosion comparisons with the photos of the channel taken prior to erosion, and for comparisons with other test patterns.

5. Finally the basin was drained and pictures were taken of the bed formation for channel configuration comparisons.

Time lapse movies were taken through the duration of each test for later examination of the erosion process.

The analysis of each run involved reviews of both the time lapse movies and photographs along with measurements of the erosion patterns from the still photographs. The 4"x5" photos taken of each run were enlarged to a workable size of 14"x11" for obtaining the desired data measurements. The amount of area eroded between structures, the spacing length, the average maximum lateral extent of erosion into the bank, and the angle of the erosion expansion were parameters needed for the analysis. The measurements were taken directly from the enlarged photos and adjusted to the proper scale. The accumulated data are shown on Table 1.

### Study Analysis

The model study proceeded in two phases. In the first phase, tests were run at a constant slope of .0008 ft/ft and discharge of 0.65 c.f.s. with various hard point structure configurations. Tests were run to obtain critical design effects for situations involving various channel alignments, flood stage overtopping, and structural alignment to the channel banks.

Initially, the tests involved the placing of hard point structures in the upstream curve and the straight reach at 5 and 7.5-foot intervals. For the initial tests, 4 lbs of rock were used in the nose and 3.5 lb/ft of rock were used in the root of each structure. This quantity of rock for the indicated discharge resulted in failure of the structures in both regions. The volume of rock was apparently insufficient to protect against the resulting scour which caused it to migrate to the bottom of the channel. Typical structure failures are shown in pictures 7 and 8.

The structures were then redesigned using 8 lbs of rock in each nose with the root remaining at 3.5 lb/ft and tested again under the same conditions. The nose portion of the structures in this case was stable in the straight reach. However, because of the angle of attack in the curved region, there was complete deterioration of the structures indicating that the hard points should not be recommended for use in sharp bends. It is, however, possible to build hard point structures in a curved reach; but, the quantity of rock needed for stability of the nose is considered excessive. In order to make it economically feasible, the required quantity of rock should be such that it would not exceed that required for revetment of the total curve. The nose was found to be the critical component of the structure system. It must be designed to remain intact or the protective system fails. The root cannot be exposed to the direct attack of the channel discharges. The 8 lb quantity of rock for the nose proved to be adequate for the remainder of the study which was run only in a straight reach as indicated on plate 1.

The root is the principal component for erosion protection during flood periods when stages overtop the hard points. Observation of the hard point structures in flood stages revealed that the root prevents leaching of the bank material from behind the nose structure. Small amounts of erosion were

Table 1  
 Summary of the Hydraulic and Erosion Computations

| Run Number | Spacing Length (ft) | Slope ( $10^{-2}$ ) | Discharge (cfs) | Test Reach Data |            | Average Maximum Lateral Extent of Erosion (ft) | Angle of Erosion Expansion (degrees) |
|------------|---------------------|---------------------|-----------------|-----------------|------------|--|--------------------------------------|
|            |                     |                     |                 | Velocity (cfs)  | Depth (ft) |  |                                      |
| 1 00 a/    | $\infty$            |                     | 0.587           |                 |            |  |                                      |
| 1 01 a/    | $\infty$            |                     | 0.457           |                 |            |  |                                      |
| 1 02 b/    | 5.0                 | 0.068               | 0.498           |                 |            |  |                                      |
| 1 03 b/    | 5.0                 | 0.120               | 0.692           |                 |            |  |                                      |
| 1 04 b/    | 5.0                 | 0.149               | 0.493           |                 |            |  |                                      |
| 1 05 b/    | 5.0                 | 0.118               | 0.479           |                 |            |  |                                      |
| 1 06 b/    | 7.5                 | 0.151               | 0.480           |                 |            |  |                                      |
| 1 07 a/    | 10.0                | 0.189               | 0.440           |                 |            |  |                                      |
| 1 08 a/    | 2.5                 | 0.149               | 0.475           |                 |            |  |                                      |
| 1 08B a/   |                     | 0.170               |                 |                 |            |  |                                      |
| 1 09 a/    |                     | 0.154               |                 |                 |            |  |                                      |
| 1 10 a/    | $\infty$            |                     | 0.652           |                 |            |  |                                      |
| 1 11 a/    | $\infty$            | 0.080               | 0.653           | 0.540*          | 0.225*     | 0.200  | 2.120                                |
| 1 12 b/    | 7.5                 | 0.080               | 0.648           |                 |            |  |                                      |
| 1 13 b/    | 5.0                 | 0.080               | 0.652           |                 |            |  |                                      |
| 1 14 c/    | 5.0                 | 0.080               | 0.653           | 0.620*          | 0.233*     | 0.226  | 0.918                                |
| 1 15 c/    | 7.5                 | 0.080               | 0.642           | 0.590*          | 0.255*     | 0.206  | 1.683                                |
| 1 16 c/    | 10.0                | 0.080               | 0.649           | 0.555*          | 0.271*     | 0.188  | 22.8                                 |
| 1 17 c/    | 5.0                 | 0.080               | 0.644           | 0.635*          | 0.226*     | 0.235  | 20.4                                 |
| 1 18 c/    | 7.5                 | 0.080               | 0.642           | 0.545*          | 0.261*     | 0.188  | 18.8                                 |

Table 1 (cont'd)

## Summary of the Hydraulic and Erosion Computations

| Run Number | Spacing Length (ft) | Slope ( $10^{-2}$ ) | Discharge (cfs) | Test Reach Data |            | Froude Number | Average Maximum Lateral Extent of Erosion (ft) | Angle of Erosion Expansion (degrees) |
|------------|---------------------|---------------------|-----------------|-----------------|------------|---------------|--|--------------------------------------|
|            |                     |                     |                 | Velocity (cfs)  | Depth (ft) |               |  |                                      |
| 1 19 c/    | 10.0                | 0.080               | 0.651           | 0.555*          | 0.260*     | 0.192         | 1.445  | 20.8                                 |
| 1 20 d/    | 7.5 30°             | 0.080               | 0.650           | 0.605*          | 0.260*     | 0.209         | 1.693  |                                      |
| 1 21 d/    | 7.5 60°             | 0.080               | 0.658           | 0.610*          | 0.256*     | 0.212         | 1.355  |                                      |
| 1 22 d/    | 7.5 30°             | 0.080               | 0.653           | 0.598*          | 0.261*     | 0.206         | 1.738  |                                      |
| 1 23 d/    | 7.5 60°             | 0.080               | 0.650           | 0.550*          | 0.285*     | 0.182         | 1.129  |                                      |
| 1 24 c/    | 2.5                 | 0.080               | 0.652           | 0.585*          | 0.253*     | 0.213         | 0.328  | 0.0                                  |
| 1 25 c/    | 3.0                 | 0.080               | 0.644           | 0.660*          | 0.226*     | 0.245         | 0.487  | 0.0                                  |
| 1 26 c/    | 4.0                 | 0.080               | 0.646           | 0.645*          | 0.234*     | 0.235         | 0.595  | 20.4                                 |
| 1 27 c/    | ∞                   | 0.080               | 0.646           | 0.590*          | 0.215*     | 0.224         | 2.468  |                                      |
| 1 28 c/    | 7.5                 | 0.080               | 0.508           | 0.531*          | 0.248*     | 0.188         | 1.038  |                                      |
| 1 28B a/   | 7.5                 | 0.080               | 0.502           |                 |            |               |  |                                      |
| 1 29 a/    | 7.5                 | 0.080               | 0.763           |                 |            |               |  |                                      |
| 1 30 c/    | 7.5                 | 0.080               | 0.650           | 0.532           | 0.277      | 0.178         | 1.242  | 17.0                                 |
| 1 31 c/    | 7.5                 | 0.068               | 0.404           | 0.398           | 0.228      | 0.147         | 0.554  | 7.6                                  |
| 1 32 c/    | 7.5                 | 0.068               | 0.550           | 0.491           | 0.259      | 0.170         | 0.689  | 9.2                                  |
| 1 33 c/    | 7.5                 | 0.068               | 0.650           | 0.482           | 0.307      | 0.153         | 1.242  | 18.8                                 |
| 1 34 c/    | 7.5                 | 0.090               | 1.004           | 0.765           | 0.291      | 0.250         | 2.122  | 24.0                                 |
| 1 35 c/    | 7.5                 | 0.090               | 0.448           | 0.478           | 0.245      | 0.170         | 0.847  | 14.3                                 |
| 1 36       | void run            |                     |                 |                 |            |               |  |                                      |
| 1 37 c/    | 7.5                 | 0.095               | 0.799           | 0.755           | 0.239      | 0.272         | 2.089  | 20.8                                 |

Table 1 (cont'd)

## Summary of the Hydraulic and Erosion Computations

| Run Number     | Spacing Length (ft) | Slope ( $10^{-2}$ ) | Discharge (cfs) | Test Reach Data |            | Average Maximum Lateral Extent of Erosion (ft) | Angle of Erosion Expansion (degrees) |
|----------------|---------------------|---------------------|-----------------|-----------------|------------|--|--------------------------------------|
|                |                     |                     |                 | Velocity (cfs)  | Depth (ft) |  |                                      |
| 1 38 <u>c/</u> | $\infty$            | 0.068               | 0.396           | 0.403           | 0.207      | 1.023  |                                      |
| 1 39 <u>c/</u> | 4.0                 | 0.068               | 0.397           | 0.430           | 0.226      | 0.572  | 15.5                                 |
| 1 40 <u>c/</u> | 4.0                 | 0.068               | 0.649           | 0.516           | 0.285      | 0.819  | 23.3                                 |
| 1 41 <u>c/</u> | $\infty$            | 0.068               | 0.641           | 0.488           | 0.234      | 1.972  |                                      |
| 1 42 <u>c/</u> | $\infty$            | 0.095               | 0.809           | 0.660           | 0.204      | 2.709  |                                      |
| 1 43 <u>c/</u> | 4.0                 | 0.095               | 0.790           | 0.785           | 0.226      | 0.933  | 17.7                                 |
| 1 44 <u>c/</u> | 4.0                 | 0.095               | 0.503           | 0.587           | 0.211      | 0.783  | 17.4                                 |
| 1 45 <u>c/</u> | $\infty$            | 0.095               | 0.493           | 0.483           | 0.188      | 1.723  |                                      |
| 1 46 <u>c/</u> | 2.5                 | 0.095               | 0.801           | 0.850           | 0.206      | 0.482  | 0.0                                  |
| 1 47 <u>c/</u> | 2.5                 | 0.068               | 0.403           | 0.434           | 0.222      | 0.162  | 0.0                                  |
| 1 48 <u>a/</u> | $\infty$            | 0.095               | 0.807           | 0.698           | 0.197      | 0.277  |                                      |
| 1 49 <u>a/</u> | $\infty$            | 0.093               | 0.804           | 0.593           | 0.183      | 0.244  |                                      |

\* Data values were translated from depth and velocity at the upstream control section.

a/ Trial test observing erosion characteristics in basin.

b/ Test of hard points in curved and straight reaches

c/ Test data used for analysis of various spacing, depth, and velocity.

d/ Test for changes in root alignment to channel.



Picture 7: Failure of the hard points in the curve due to insufficient quantity of rock in the nose. The rock migrates to the bottom of the channel.

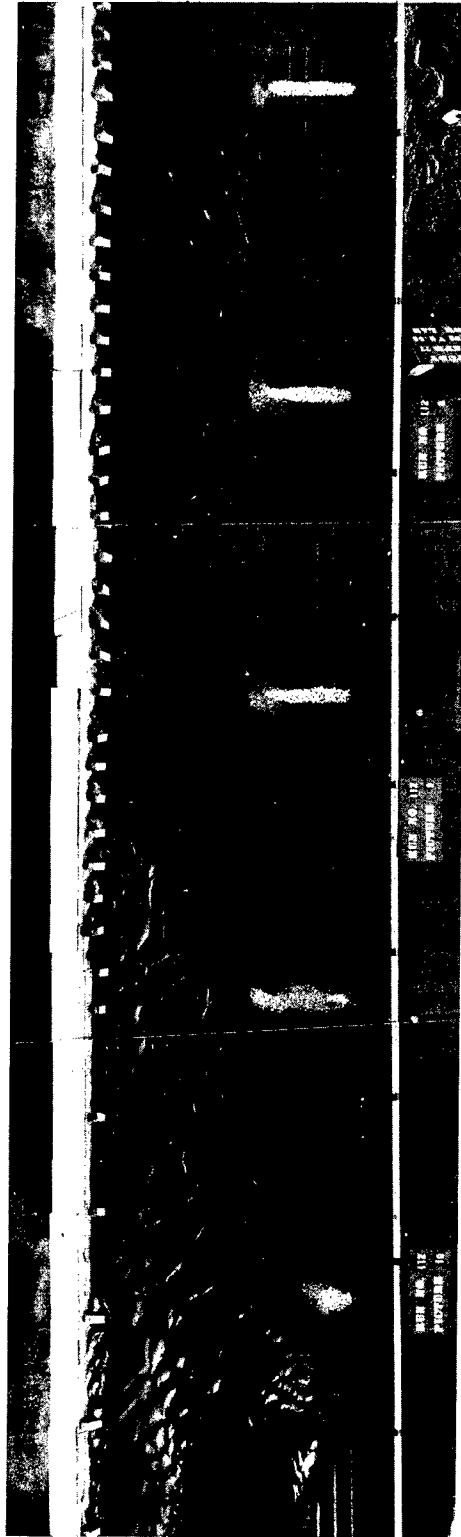

Picture 8: Failure of the hard points along a straight reach due to insufficient quantity of rock in the nose. Notice the crossing of the flow with little effect resulting on the downstream structures.

observed, however, off the end of the root due to turbulence created at that location. The root remained stable during these flood conditions with some rock migrating down into the scoured areas to provide minor erosion protection.

The effects on the erosion pattern resulting from root alignment changes were observed with a 7.5 foot spacing and alignment angles of  $60^{\circ}$  and  $30^{\circ}$ . The angles were measured upstream from a line perpendicular to the channel. The erosion patterns for the tests are shown on pictures 9, 10, and 11. A comparison of the pictures shows the erosion patterns to be essentially the same. However, the erosion in the  $60^{\circ}$  alignment is less than that for both the  $30^{\circ}$  and the perpendicular alignment. The reason for this is that in the  $60^{\circ}$  alignment much of the root is, in effect, used for bank erosion protection. Unless the root is designed for this windrow type of protection there is no need for, nor particular benefit from, angular root alignment to the channel.

Analyses of the root indicate that the root should be designed for protection against flanking of the nose during flood stages as well as for protection of minor erosion scallops on the upstream side of the structure.

Initially, Phase II of the study involved the observation of the lateral erosion patterns developed around various spacings of the revetment structures under conditions of constant discharge of 0.65 c.f.s. and slope of 0.0008 ft/ft. Spacings used were 2.5, 3.0, 4.0, 5.0, 7.5, and 10.0 feet. Tests with no structures were made to indicate the maximum probable erosion. Structure spacing for these runs were considered to be infinite.

Investigations revealed that for this homogeneous bed material there was a semilogarithmic relationship between the structure spacing and the amount of bank erosion. This relationship is shown on plate 3. Bank erosion "Y" was expressed as the average maximum lateral extent of erosion scallop into the bank for a particular spacing, and "L" was the spacing length. A plate showing these typical measurements is shown on plate 4. From the tests it was determined that there was no evident optimum structure spacing.

It was noted that structure spacing at close intervals did have a smaller degree of erosion than those of at greater intervals. To achieve this lesser degree of erosion, however, it takes many more structures per unit length of test reach.

In conjunction with the lateral erosion measurements the erosion expansion angle was measured from each structure and averaged for each test interval. The angle of expansion was measured as shown on Plate 4. For most spacing lengths the expansion angle was consistently measured at approximately 20.0 degrees, equivalent to a length ratio of 2.6



Picture 9: Development of erosion pattern with hard point roots aligned perpendicular to the channel bank.



Picture 10: Development of erosion pattern with hard point root alignment at 30 degrees upstream from the perpendicular position. (Note the deterioration of the root.)

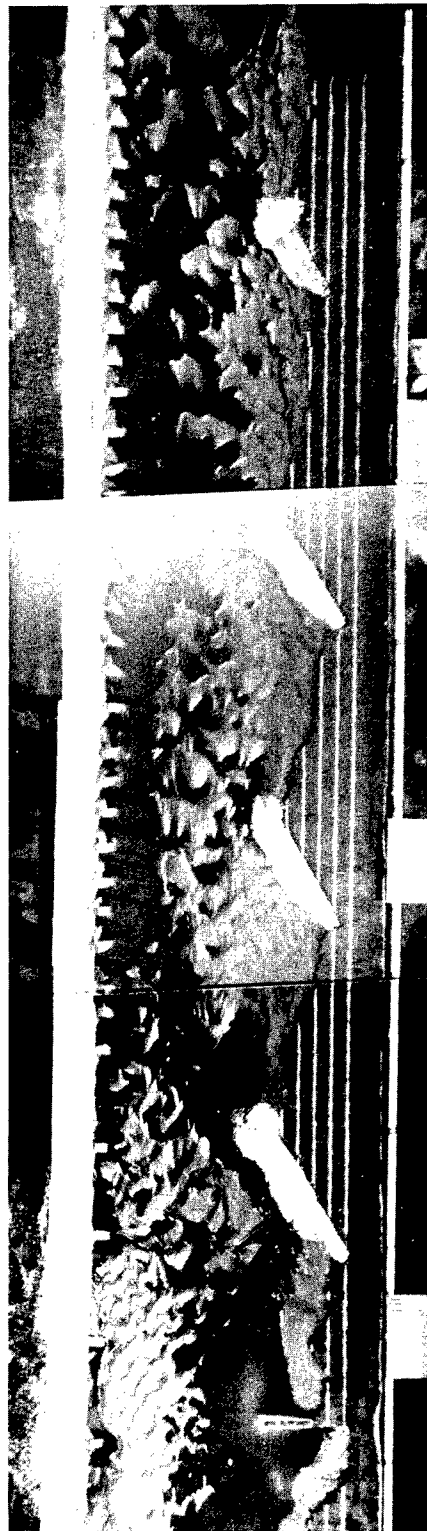

Picture 11: Development of erosion pattern with hard point root alignment at 60 degrees upstream from the perpendicular position. (Note the deterioration of the root.)

horizontal to 1.0 lateral. However, for spacing lengths less than 4.0 foot, full development of the angle involving the formation of back eddy scallop directly downstream of the structure along with the lateral erosion scallop was not evident. For this situation the extent of erosion was due to the interacting turbulence created from the existing structures. A zero expansion angle was determined for these spacing lengths.

The relationship developed from conditions of relatively constant depth and velocity in the reach aroused curiosity regarding the effects of different velocities and depths on the semilogarithmic erosion relationship. With this in mind, the testing was continued.

Continuation of Phase II testing involved changes of depth and velocity for spacing of 2.5, 4.0, and 7.5 feet, as well as the infinite spacing condition. The investigation again revealed semilogarithmic lines; however, these lines formed different slopes and orientations giving different  $\bar{Y}$  values for the same spacing. The resulting investigation concluded that the erosion scallop was related to the spacing by the Froude Number,

$$F = \frac{V}{\sqrt{g D}}$$

The relationship is as follows:

$$\text{Log } \frac{\bar{Y}}{D} \text{ Versus } \text{Log } F \text{ and } \frac{D}{L}$$

- where: D = average depth of the reach determined from cross sections taken at each structure in the test reach
- $\bar{Y}$  = average maximum lateral extent of erosion between structures
- V = average velocity in the test reach
- L = spacing length between hard point structures

A graph for the relationship is shown on Plate 5. The final analysis of the relationship shows that the degree of erosion in the test basin is dependent on the average velocity, average depth, and spacing.

Further analysis of the expansion angle again resulted in measurements consistently around 20.0 degrees. Complete development of the expansion angle did not occur for spacing less than 4.0 feet. Spacing less than 4.0 feet is so close together that the structures interfere with one another's erosion development. Also, for some spacing lengths greater than 4 feet the velocities in the channel were not enough to develop the full expansion angle, and thus, expansion angles varied

between zero and 20 degrees. The angle of expansion from these particular rock hard points was determined to be 20.0 degrees for a fully developed erosion pattern and characteristic of the homogeneous material in the test basin. The relationship between the average velocities of the test reach and angle of erosion expansion is shown on Plate 6. From the graph it appears that the velocities must be greater than approximately 0.50 f.p.s. for the angle of erosion expansion to be fully developed for any spacing 4.0 feet or more.

### Conclusions

In line with the objectives as stated in the introduction portion of this report, the following principles represent the findings of the conducted model studies.

1. The nose of the hard point is the principal design component for protection against failure of the system. The quantity of rock used in the nose of the hard point is critical to the stability of the system. The nose structure must have enough rock to remain intact or the structure integrity is lost. If the nose of the hard point fails, the quantity of rock in the root will likely not be adequate to protect against the erosive forces of direct flows.
2. For the provision of protection in the case of overtopping the structure during flood stages, the root is the principal design component. Flanking of the nose structure should be a major concern during the passage of flood flows. The design of the root should be sufficient to inhibit leaching of the soil from behind the nose section. The root should be designed to protect against flanking or back eddy erosion.
3. Placement of hard points in various situations from acute curves to straight alignments can be accomplished and can be effective. Placement of rock hard points along an acute channel curve, however, is not recommended because of the extreme attack angle of the flow upon the nose and root. Excessive amount of rock must be utilized for protection against failures from extreme velocities and turbulence caused by concentrated flows. In those cases it would probably be more advantageous to design continuous bank revetment or windrow revetment.
4. Alignment of the hard points involves only the root portion of the structures. Orienting the root upstream at an angle to the flow serves no apparent useful purpose. When the angle of the root is small, the erosion characteristics are similar to those with a perpendicular root. When the angle is large, the root tends to parallel the eroded bank and direct flow attack occurs on the root. The root is then utilized in a windrow type of situation. Since the roots are usually not designed for that purpose they would be apt to fail.

5. Various spacings for hard point structure placement had definable effects on the erosion pattern for the various tests. There was no detectable optimum structure interval indicated from the erosion patterns in the model. The greater the spacing between structures, the more extensive the degree of bank erosion. The amount of bank protection provided would then depend upon the relationship between the cost of the project and the value of the property protected.

6. There is a definite relationship involving velocity and average channel depth on the erosion pattern. A semilogarithmic plot relates the amount of lateral bank erosion to the spacing and the Froude number. An increase in the Froude number and the spacing length apparently results in increases in the extent of lateral erosion.

The study indicated that the expansion angle of the erosion scallop was a parameter characteristic of the basin material and the turbulent action created by the existing hard point structures. The expansion angle for the study consistently remained around a maximum of 20.0 degrees.

Angles of erosion expansion from zero to 20.0 degrees were typical for study situations in which there was a minimum amount of turbulent action off the structure nose or the spacing was so close that the erosion scallop could not develop.

It is apparent that for spacing less than 4.0 feet, there is no angle of erosion expansion developed for any velocity. At velocities around 0.40 to 0.50 f.p.s. the angle of erosion expansion varies from zero to approximately 20 degrees for all spacing. Velocities from 0.50 to the test maximum of 0.85 f.p.s. form a fully developed erosion pattern for all spacing.

The model tests are considered to be reliable because many of the model runs were repeated as a check of the model consistency. Comparisons of the repeated runs showed results with only minor differences, if any.

Further studies on hard point structures could be made to provide design criteria for the root and nose designs under various angles of flow attack.

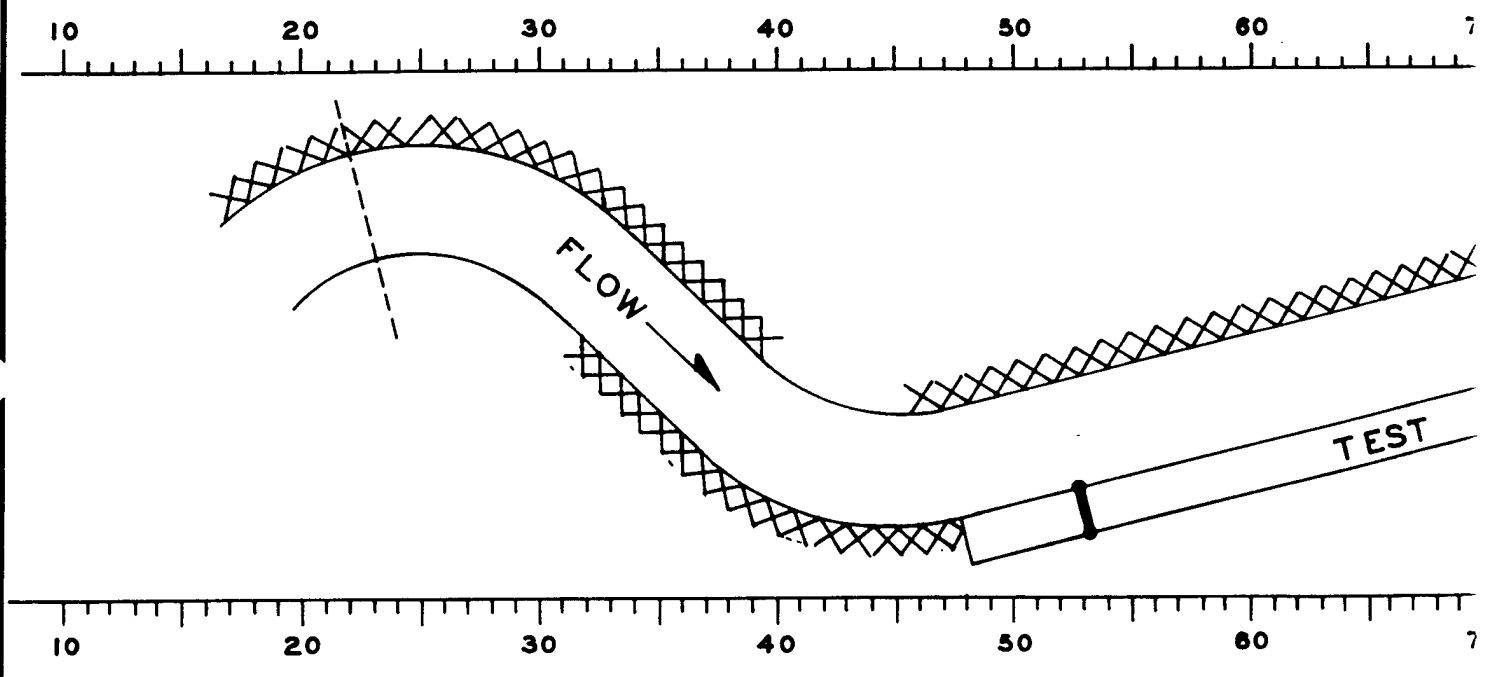

SCALE: 1 INCH = 8 FEET

| LEGE          |
|---------------|
| CONTROL X-SEC |
| CONTROL HARD  |
| FIXED REVETM  |

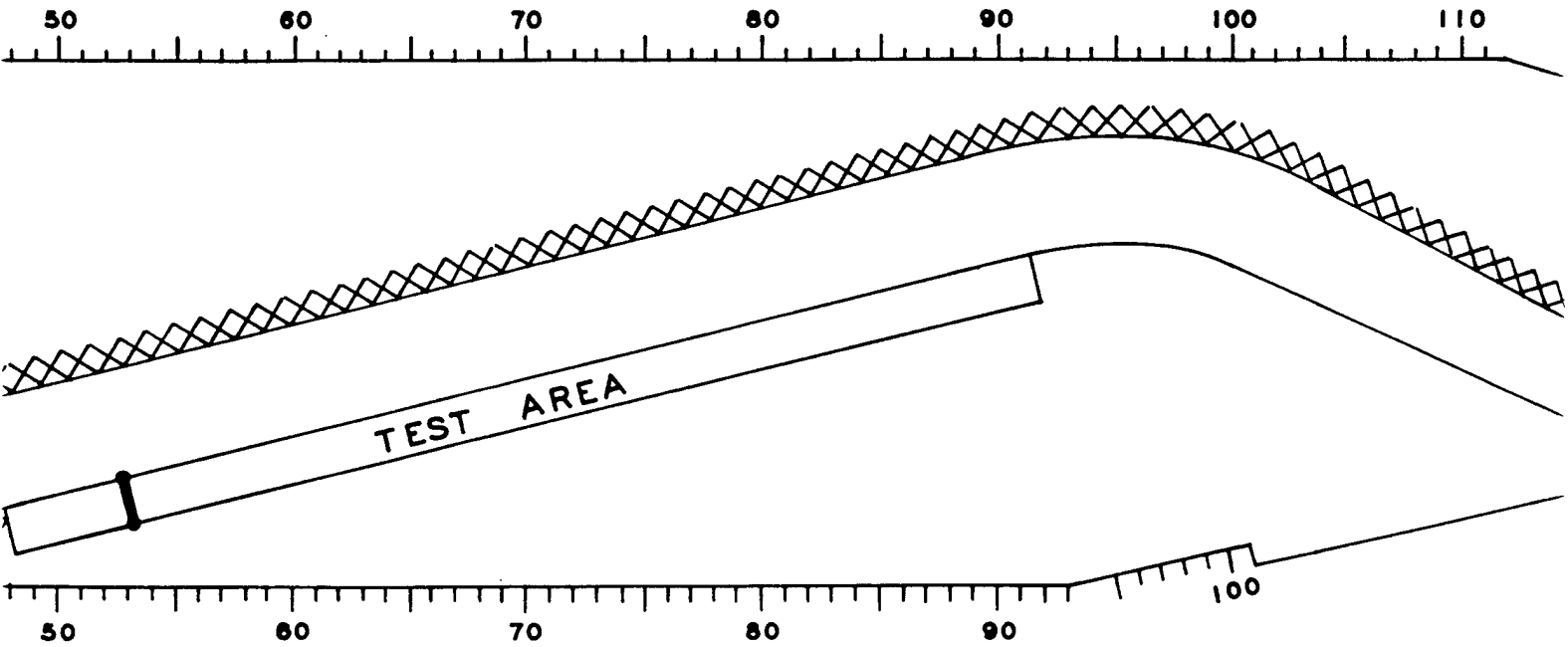

SCALE: 1 INCH = 8 FEET

| LEGEND            |        |
|-------------------|--------|
| CONTROL X-SECTION | -----  |
| CONTROL HARDPOINT | —————  |
| FIXED REVETMENT   | XXXXXX |

SECTION 3  
EROSION CONTROL  
BASIN  
U. S. ARMY ENGINEER  
CORPS OF ENGINEERS  
NO.

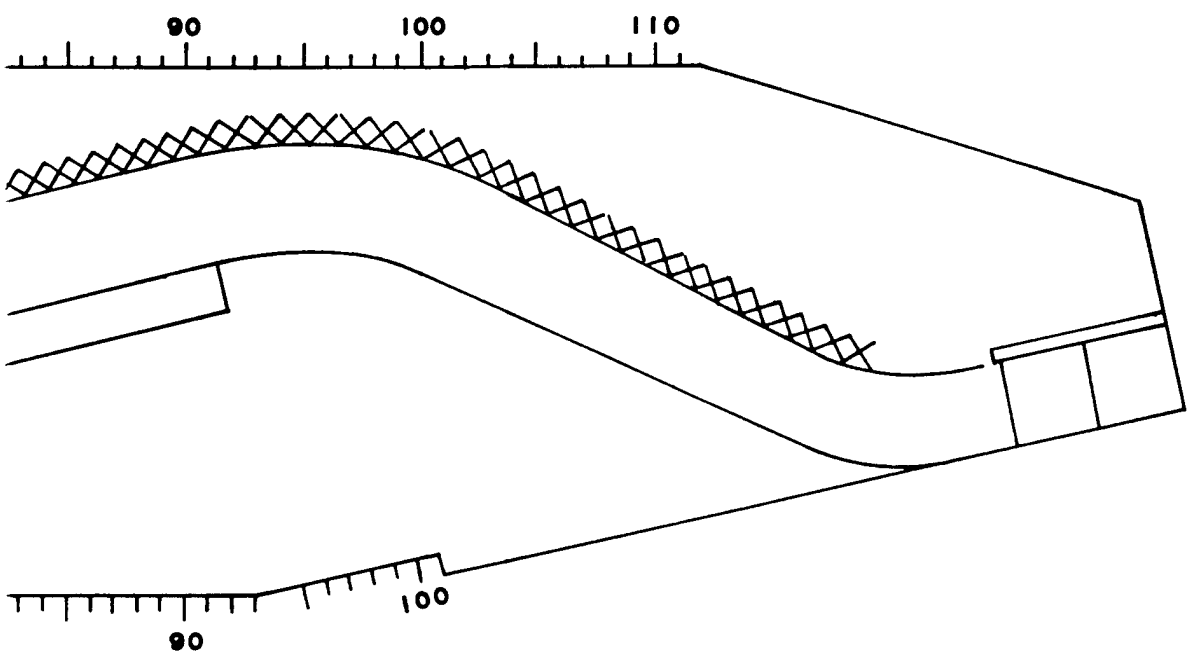
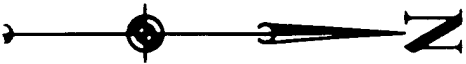

SECTION 32 DESIGN STUDY  
**EROSION CONTROL USING HARD POINTS**  
BASIN LAYOUT  
U. S. ARMY ENGINEER DISTRICT, OMAHA  
CORPS OF ENGINEERS OMAHA, NEBRASKA  
NOV. 1977

PLATE NO. I