



DMSTTIAC

*Defense Modeling, Simulation and Tactical Technology
Information Analysis Center*

DMSTTIAC TA-97-02

An Assessment on Modeling & Simulation of Infrared Sensor Systems

A Modeling and Simulation Assessment

Mitchell W. Douglas
Associate Engineer
IIT Research Institute

Published by:
DMSTTIAC
IIT Research Institute
7501 South Memorial Parkway, Suite 104
Huntsville, Alabama 35802

Approved for Public Release;
Distribution is Unlimited

June 1997

DTIC QUALITY INSPECTED 4

19990604 030

INTRODUCTION

Modern military systems being fielded are becoming increasingly more complex and expensive, and challenge traditional training, analysis, and test & evaluation methodologies. As a result, there is more and more pressure to use modeling and simulation throughout the development cycle of these military programs. The need for modeling and simulation, especially Distributed Interactive Simulation (DIS), is becoming more apparent for operational test and evaluation as well as for defining military training requirements. In the process of system design and development, we depend more on the high-fidelity deterministic and statistical modeling and simulation approaches.

One thing that needs to be kept in mind is the fact these simulations are just what they are, mathematical models of systems interacting to play out a scenario and provide results. These results are analyzed and decisions are made. Therefore in order to interpret the results, it is imperative that the mathematical models represent the system and that the input data is understood. As we become more dependent on modeling and simulation, the approaches taken in generating the "synthetic real world" must take into consideration the anticipated advancements in the system being modeled. The objective of this assessment is to look at some of the methodologies used in modeling and simulation of infrared (IR) search-and-target acquisition systems, to address the generation of synthetic IR imagery, and to identify issues associated with modeling and simulating IR imagery in real time as 3rd generation IR technology matures.

PROGRESSION OF IR SENSORS AND PERFORMANCE MODELING

Over the past 30 years, IR sensor technology has advanced tremendously in the areas of night vision, target acquisition, and missile seeker applications, from single element detectors with a dedicated preamp performing a sequence of horizontal scans to multiple detectors performing a parallel scan. Soon after, integrated circuit technology along with advances in thin films have allowed for the development of linear detector arrays with charge coupled device (CCD) multiplexer and preamp performing parallel scan. In more recent years, 2nd generation sensor technology has advanced the development into high-density two-dimensional focal plane arrays (FPA). *Figure 1* shows this evolution of IR sensor technology.

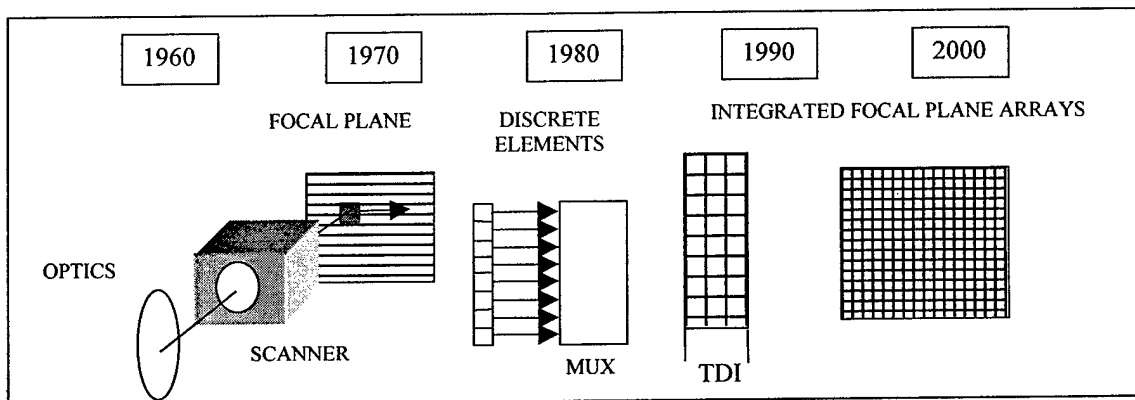

Figure 1. Evolution of Imaging IR Sensor Technology

With the complexities of improved IR sensors/seekers came the complexities in modeling to describe the performance of those systems. In general, the modeling has progressed from the non-imaging to the imaging types of IR sensor/seeker. Of significant importance to the modeler is the characterization of the background clutter. Therefore, as technology and modeling/simulation capability improve, advances in the characterization of the background clutter have been required.

Early IR System Modeling

The earliest weapon systems implementing IR target acquisition and guidance were designed for anti-aircraft missiles. These systems were typically a single element detector utilizing a reticle with a nutating scan to generate guidance signals. They were lock-on-before-launch systems, which depended on a high enough signal-to-noise ratio for target lock. The reticle extent and the scan pattern resulted in rather large fields of view (2-3 degrees) and even though reticle design attempted to suppress clutter effects, the background clutter (both terrain and cloud) could produce a signal which was significantly higher than the signal from a point source target. The contribution of clutter to the overall signal was, in large part, ignored and the target acquisition modeling process normally assumed a "blue sky" background situation. The important variables in modeling (equation 1) these systems were the system sensitivity (Noise Equivalent Irradiance (NEI)), "effective" target radiant intensity (J_{eff}), range (R) and atmospheric transmission (τ_a). If clutter was considered at all, it was introduced as a multiplier to the seeker signal-to-noise (S/N) required for tracking.

$$\frac{J_{eff} \cdot \tau_a}{R^2} = \frac{S}{N} \cdot NEI \quad (1)$$

The next generation of IR sensor/seeker systems was considered "pseudo" imaging. By scanning the system field of view with one or more detectors, an image of the scene can be created. By storing the signal response of each detector during each dwell time of the scan cycle, the scene can be processed as an image. By interrogating the stored image, guidance control commands can be initiated autonomously or by man in the loop. Now, the complexity of modeling the sensor/seeker performance is growing. Background clutter now becomes a variable in the model equation and must be represented as accurately as possible.

$$\frac{J_{eff} \cdot \tau_a}{R^2} = \frac{S}{N} \cdot \sqrt{NEI^2 + NEC^2} \quad (2)$$

Equation 2 represents the case where the target is no longer against a "blue sky." NEC represents the background equivalent irradiance. This process assumes normal distribution of the background clutter; therefore, it can be root summed with the sensor internal noise. There is much data available which characterizes the background in terms of the RMS level in °C. Although it is recognized that this is a simplistic

characterization of the very complex background, its use is easily adapted to modeling with results comparable to test data.¹ Modeling has evolved from the statistical efforts of test and data collection to a more deterministic higher fidelity modeling approach, which includes specific sensor system parameters, spatial filters, and acquisition and tracking algorithms. The clutter input for these models can utilize actual or simulated imagery developed from statistical parameters.

The next generation of sensor developments was full imaging utilizing staring focal plane arrays (FPA). These sensor systems have created the most controversy regarding the different methods to model performance against targets in a variety of backgrounds (i.e., deterministically or statistically). The modeling approach, as shown in *Figure 2*, is based on that initially configured for man-in-the-loop (MIL) target detection and acquisition systems. For MIL systems the performance is based on minimum resolvable temperatures (MRT) and minimum detectable temperatures (MDT). These can be derived from models which characterize the target as a delta temperature through the optics, FPA, electronics, signal processor, display, and observer. Ultimately it is the observer's capability of distinguishing the target from the background based on the

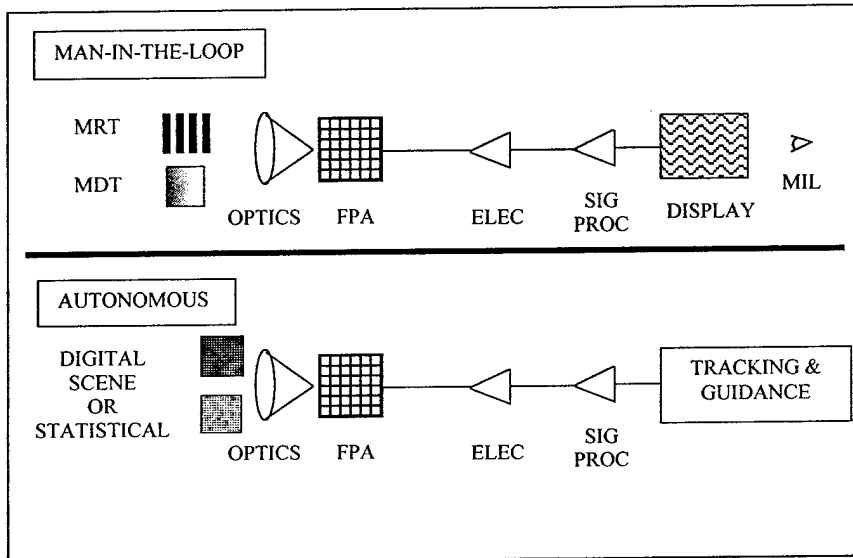

characteristics of the IR sensor that characterizes performance. The display and observer aspects are unique to MIL modeling and are not generally considered for autonomous performance modeling.

Figure 2. Modeling of Imaging IR Sensor Systems

Autonomous modeling can be explicitly scene based, with either real or synthetically generated imagery, or statistically based using parameters which represent clutter scenes. The most accurate method of modeling clutter is using actual scene imagery. Synthetically generated scenes can also provide accurate clutter data for modeling but synthetically generated scenes are only as good as their input data or the fidelity of the scene generator. The disadvantage of this method is that it is computationally intensive and requires elaborate scene data collection, which cannot realistically cover all regions. An alternate type of modeling incorporates statistical models of clutter. This allows for faster execution times and a wider variety of clutter categories. The disadvantage with statistical clutter modeling is that it is often too general and does not consider the detail of background clutter that would be utilized in a scene-based imaging simulation.

Progression of Clutter Modeling

Statistical background clutter modeling has evolved from the simple subjective to the more complex. Initially, clutter was characterized as “high” or “low” and modeled with an appropriate gain applied to the signal-to-noise ratio. As the technology moved toward imaging systems clutter became an important element in modeling performance. At that time (70’s – 80’s) an adequate methodology was not developed to quantify its effect. During the 80’s the methodology adopted to model clutter made use of a background temperature with an associated standard deviation. The standard deviation of the background would be converted to an equivalent rms power density and statistically summed with the internal noise of the sensor system as a noise equivalent clutter (equation 3).

$$NEC = \omega \cdot f_{cl} \cdot \sigma_o \cdot \frac{dL}{dT_{BKG}} \quad (3)$$

$$\frac{J_{eff} \cdot \tau_a}{R^2} = \frac{S}{N} \cdot \sqrt{NEI^2 + NEC^2}$$

This methodology was an improvement over the subjective type of clutter characterization; however, there were still several notable inadequacies. For instance, the critical spatial elements of clutter were not being modeled directly, and there was no traceability to the actual spatial content of the scenes. There were also discrepancies between modeled performance and field-tested performance. Presently, statistical clutter modeling techniques have grown out of efforts to include both the power and spatial effects of IR clutter.

Two-dimensional power spectral density (PSD) representations have been traditionally utilized in various forms for characterizing clutter. Of these various representations, one (Model A shown in *Figure 3*) has become a popular statistical model of IR backgrounds and has been found to be a more accurate characterization of the power and spatial effects of IR backgrounds.²

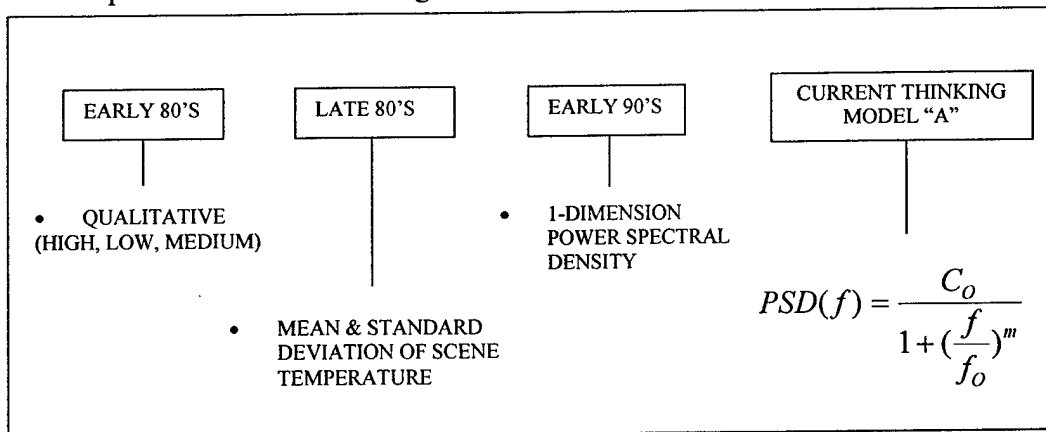

Figure 3. Evolution of Characterizing Clutter

Through analysis of these several forms of PSD representations of clutter, Model A appears to most closely fit the PSD curve of actual clutter imagery, particularly in the higher spatial frequencies important for small target detection.³ Model A includes spatial characteristics of clutter, unlike previous statistical models that consider only the mean and standard deviation of background temperature. Model A is computed in the frequency domain and approximates the PSD of the scene. The parameters that characterize this type of model include standard deviation of background temperature (σ_o), correlation length (R_o), and the power rolloff exponent (m). An example of these parameters defined for several environment types is shown in *Table 1*. In general, σ_o represents the deviations of scene temperature, or the background uniformity. R_o describes the spatial characteristics, or size of the background clutter components, and m indicates the quantity of high spatial frequency clutter relative to the low spatial frequency clutter.

$$f = \text{spatial frequency (fx, fy)} \quad C_o = km \sin(k\pi/m) R_o^2 \sigma_o^2 \quad PSD(f) = \frac{C_o}{1 + (\frac{f}{f_o})^m}$$

$$f_o = 1/2\pi R_o \quad k = 1.75 \text{ for } m < 2.5$$

$$k = 2.0 \text{ for } 2.5 < m < 3.5$$

Table 1. Initial Model A Library

BACKGROUND TYPE	ROLL OFF	CORRELATION LENGTH	STD. DEVIATION
	m	Ro (M)	σ_o (°K)
Open Ocean	2.9	5.3	0.86
Overcast Clouds	2.6	8.0	2.8
Snow Covered	3.2	16	1.5
Forest			
Plowed Field	2.5	23	3.1
Forest	2.8	5.3	2.8
Semi Arid	2.4	8.0	7.3
Shrubs/Hills			
Urban	2.2	3.2	4.9

LEVELS IN MODELING IR SYSTEMS

The modeling of IR sensor systems in realistic scenarios has become extremely complex. This is due to the high resolution nature of modern sensors, the complex nature of filtering and signal processing algorithms, and the interrelated nature of the large number of parameters that affect the target signature, the background's clutter signature, the engagement scenario and the intervening environments. Deterministic models are useful and necessary for detailed analysis of IR sensor system development and refinement. However, limitations exist for broad and early comparative analyses. Empirical or statistical models are attractive and needed for trade-off assessments as well as test and evaluation. But, these models require additional sophistication in accommodating the effects of background clutter and need an extensive verification/validation process with actual IR sensor test data.

Simplistic models may or may not be sufficient for predicting the performance of full imaging systems. Some would agree that full imaging IR systems should be evaluated

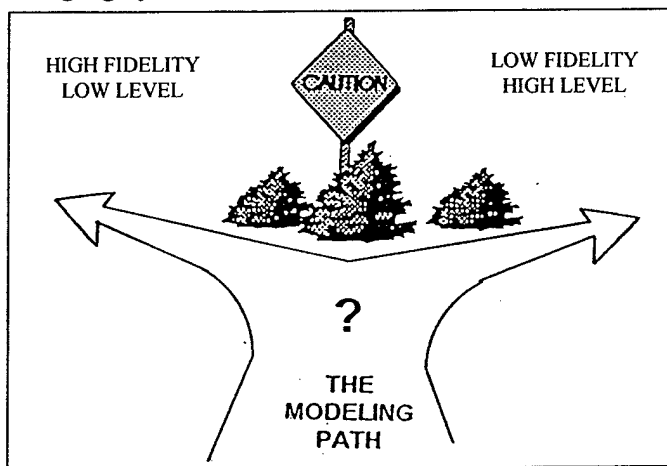

using a high fidelity model that includes the exact representation of the optics, FPA, non-uniformity correction and signal processing algorithms. Others may claim that a less detailed generic model is sufficient for system evaluation. Both are correct. The dilemma of choosing a modeling approach is in understanding the merits of the model. *Figure 4* illustrates this dilemma.²

Figure 4. The Modeling Path

High Fidelity Modeling and Simulation

The high fidelity, thorough, point-to-point model process is well understood and useful. In general, it requires a very extensive input data requirement, a long run time (even with current computing technology), and can produce differing results with small input data changes. This process is extremely valuable in developing the exact system figures of merit and signal processing algorithms. High fidelity models are component-level, physics-based, and are typically used to generate the performance statistics for input to lower fidelity models. An example of a generic high fidelity model of a submunition implementing an IR sensor/seeker is shown below in *Figure 5*.

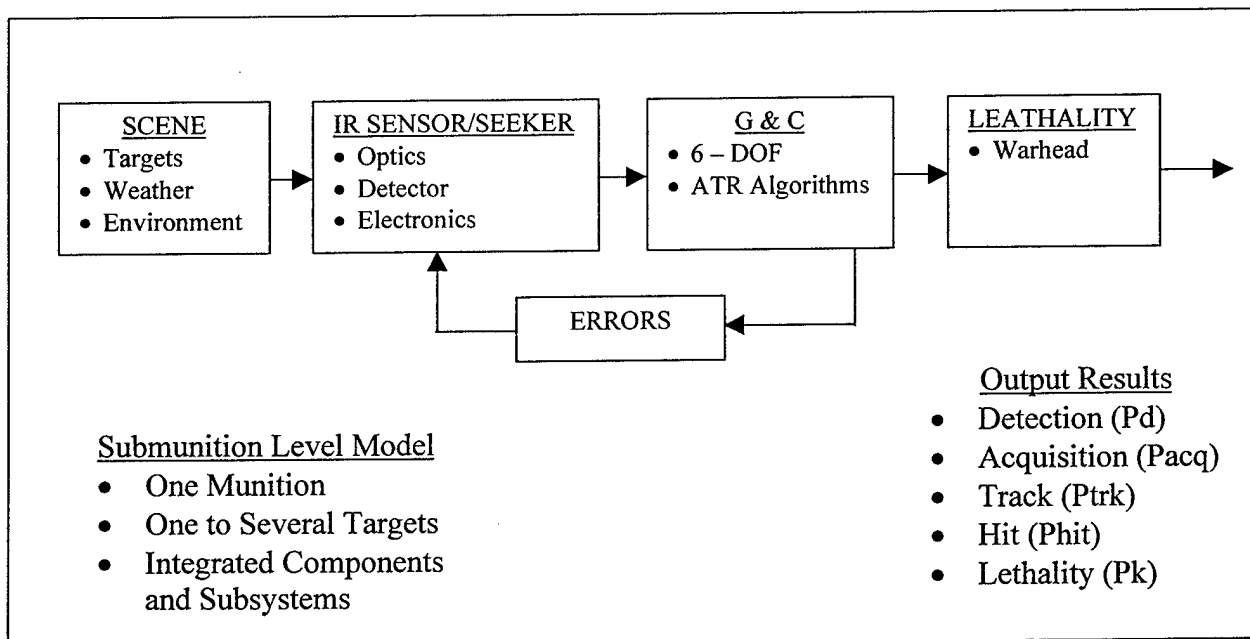

Figure 5. Generic High Fidelity Weapon System Model

This is a general representation of the submunition level model. It is one system consisting of integrated components and subsystems. The input into this system model is an IR scene with one or multiple targets, weather and environmental conditions. The results of modeling end-to-end (simulation) are typically a list of statistics, such as probability of detection (Pd), probability of acquisition (Pacq), probability of track (Ptrk), probability of hit (Phit), and probability of kill (Pk). However, each subsystem and integrated component has an output serving as input into the next model. For example, the IR sensor model consists of optics, detector, and electronics models. The sensor model takes scene radiance data, with spatial variation, as input and outputs analog voltage levels. The analog signals are converted into digital intensity levels and stored in an indexed array for input into the guidance and control model, which may contain the automatic target recognition algorithms. The important thing to keep in mind is that confidence in the output data is based on the fidelity of the models and the representation of the synthetic input scene.

The U.S. Army Night Vision and Electronic Sensors Directorate (NVESD) has focused much attention on the appropriate characterization of IR sensors in simulation, and the synthetic IR scenes that drive them. Different IR sensors have distinctly different levels of search and target acquisition performance (different sensitivity, resolution, etc.) NVESD's research has shown that the realistic simulation of IR search and target acquisition (STA) systems requires two things: appropriately-characterized sensor effects, and physically reasonable target and clutter background scenes synthesized to at least the resolution limit of the sensor. For some modeling techniques, the sensor is characterized by a unique modulation transfer function (MTF) and noise phenomenon that defines just how much spatial and amplitude detail it can present to the viewer. There is a concern that less simulated scene fidelity than the sensor can actually resolve frequently results in a mischaracterization of simulated sensor performance. This will result in a false assessment of performance.

NVESD presented a paper at the 1997 Spring Simulation Interoperability Workshop addressing the fidelity requirements for IR simulation.⁴ In this paper, fidelity is defined as the amount of spatial and amplitude signature resolution in the synthesis of the IR scene. Spatial resolution can be increased in real-time computer graphics by increasing the number of object model facets or by increasing the resolution of the applied texture. Amplitude resolution refers to the number of bits representing pixel intensity in the output frame buffer where the scene geometry is rendered, and is typically 8, 10, or 12 bits. Since increasing fidelity, usually spatial resolution, generally reduces the sustainable frame rate, it is very useful to define an objective measure of the fidelity specifying a minimum resolution required to support IR sensor simulation to some acceptable level.

NVESD has proposed just such a minimum resolution model, referred to as the MRT/MRC and MDT - Based Fidelity model.⁵ Since all computer image generators have finite resources (texture memory, CPU processing power, raster managers, graphics, pipelines, etc.), this model can be used to put an upper bound on how much fidelity to apply as a function of range. The basis of this model is that the atmosphere and sensor combine to form a filter that places an upper limit on the amount of spatial resolution a simulated imaging IR sensor system can resolve. MRT and MTF limited curves are generated by attenuating the background contrast detail through the atmosphere as a

function of range to produce an apparent contrast. These apparent contrasts are then used to find their corresponding spatial frequency "cutoffs" from the sensor MRT and MTF curves (f_c). These f_c 's are then mapped to an associated resolution by assuming worst-case normal-presented background to the sensor field of view (FOV), and applying the Nyquist sampling criteria:

$$R_{\max/\min} = \text{Range} / 2f_c \quad (4)$$

Resolution in excess of R_{\max} will be completely attenuated, while resolution in excess of R_{\min} will not be resolvable.

In cases where the resolution requirements are high, all of the resolution need not necessarily be implemented by increasing facets (polygon count). Polygon vertex emission may be used to represent the mean radiant emittance, while high-resolution texture representative of the surface thermal variation might be used in addition to vary this mean emittance. The standard deviation of this variation would be representative of the surface optical and thermophysical property distribution. Application of texture is a practical way to meet the MRT-Based resolution requirements and enhance realism in most cases. However, texture cannot always make up for lack of geometric detail. Such terrain detail is obviously important in representing lines-of-sight (LOS) correctly, and in representing hill-lines and skylines appropriately. Meter and sub-meter detail is often required to represent terrain realistically; however, it results in terrain databases of millions of facets. Clearly, to render all of these terrain facets and update them with appropriate emissive components for every frame time requires some innovative techniques. This is the main issue with implementing synthetic IR scenes in a DIS environment where the simulation is playing out in real time.

Distributed Modeling and Interactive Simulation

Distributed modeling and interactive simulation are becoming more and more complex and are requiring detailed modeling of the various systems and subsystems aboard an entity. Currently, the state of an entity in DIS is represented by the Entity State Protocol Data Unit (ESPDU) and does not provide enough physical state parameters for proper representation in a dynamic situation, specifically IR signature and background scenes. Typically, an IR signature of an entity, such as an aircraft, may be represented under a steady state condition by which the IR signature is derived from a database using two parameters, airspeed and altitude. Consider the aircraft in a dynamic state, such as a dogfight. The aircraft is pulling higher G's in a tight turn at a lower altitude and slower airspeed. One would expect to see the engines at full throttle, thus presenting a different IR signature than would be expected under a steady state condition with the same parameters. To provide a more realistic model of an entity, more physical state information is necessary.

Several concepts of providing entity signature data within DIS are being pursued. The concepts have included:

- Sending the signature data continuously over the network with the ESPDU.

- Issuing a Data Request to the system where the requested entity is hosted, then returning the necessary data to the requester.
- Inclusion of a representation index in the ESPDU to access a database of signature representations of the entity of interest.

There are some drawbacks to each of these concepts. The first and second concept involving transmission of data over the network pose significant bandwidth issues since some signature representation files can be quite large, and with rapid changes in the signature overloading the network is probable. Latency issues also arise, especially in the case of having to request the data, and then waiting to receive the data before any calculation can be performed. This is unacceptable for high performance aircraft or weapons systems demonstrating search, target acquisition and/or hit to kill. The drawback to the representation index is that the signature data to be used during the exercise will have to be disseminated to participating sites before the exercise begins. This limits the opportunity for another simulation to "jump" on the network to participate.

It has been the goal at the U.S. Army Test and Experimentation Command (TEXCOM) at Ft. Hunter Liggett, CA to develop realistic real-time simulation of the tactical battlefield as seen through weapons systems sensors. These efforts are supported by the creation of a high-resolution signature database and perspective view generation research administered under the TELLUS program by TRADOC and conducted at the Naval Postgraduate School in Monterey, California.⁶ The following discussion is from reference 6.

From a technical point of view, realistic real-time digital simulation of the tactical battlefield presents a challenge. This is because the objective of distributed modeling and interactive simulation is to allow real-time virtual weapons substitution into live force-on-force engagements with sufficient sensor fidelity to allow analytical evaluation of weapon effectiveness. The challenge is the rapid generation of metrically accurate battlefield views, which are as identical as possible to actual sensor displays for search and target acquisition from an autonomous weapon and/or man-in-the-loop point of view. What's more, in order for systems simulating different sensors (visual and IR, for example) to interoperate, accurate sensor response calculations must be performed from a common objective representation of the battlefield and its environment.

Real-time rendering for simulation of realistic target signatures in high-resolution terrain requires the solution of atmospheric transmission and surface state calculations in real time. This problem has been solved through the use of rendering look-up tables in the TELLUS simulator. This approach divides the rendering problem into the off-line calculation of quantized rendering solutions and a real time look-up table calculation of sensor spectral response in a high speed simulator.

By dividing the permanent terrain and target material properties from the rapidly varying view geometry encountered during realistic real-time scene rendering, realistic rendering speed can be maintained in operator-controlled joystick vision simulations. This problem division allows for the exchange of sensor response information between distributed simulators using non-real-time data communications capabilities within the

High Level Architecture (HLA). To accomplish this task within the HLA environment minimum data structures must be defined which must be communicated to calculate realistic real-time sensor signatures of the same battlefield using simulators of different sensors. This is shown in *Figure 6*.

Three layers are shown in the figure. The bottom layer is the Real-Time Interface (RTI), which represents a communications layer between the two simulators. The middle layer represents Federation specific code, which automates the facilities, formats, and services within a Federation. The top layer contains the simulators, which interoperate. The area between the two indicates a common data definition reference frame. It is in this common data reference frame where the data structures reside that perform the necessary calculations for real-time signature rendering. This design provides the mechanism for implementing major first order effects and represents a next step over other rendering techniques performed in most simulators.

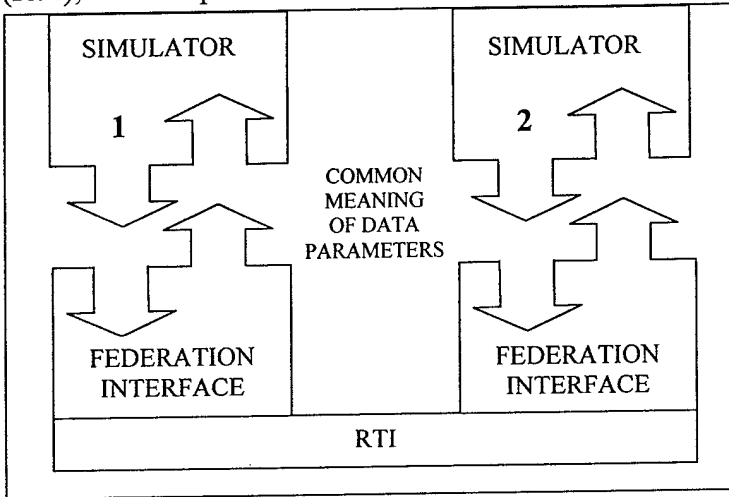

Figure 6. HLA Context

provides the mechanism for implementing major first order effects and represents a next step over other rendering techniques performed in most simulators.

The common data reference frame (see *Figure 7*) shows five levels of interrelated data, which if exchanged, will allow interacting simulators to calculate consistent images. The first layer is the terrain or objects database. This contains the material index (M) and

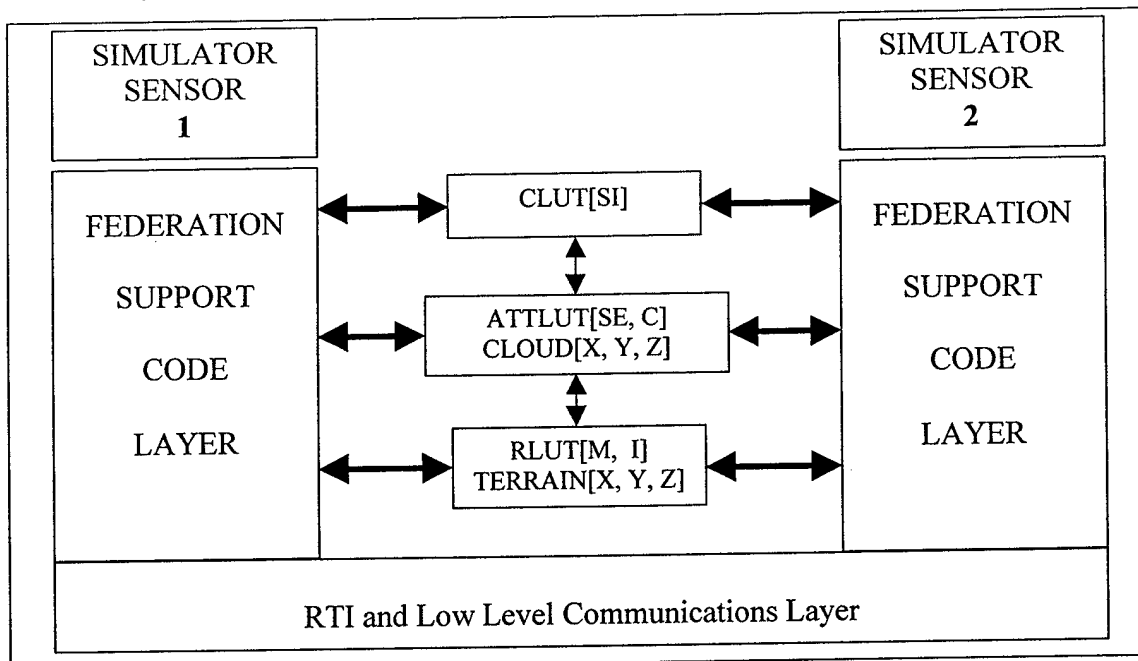

Figure 7. HLA Sensor Federation Data Interface Diagram

incident energy (I) as a function of geometric location X, Y, Z. The indices M and I are interpreted by the rendering table (RLUT) in the second layer to produce a surface emitted energy index (SE). This layer also requires a geometric volume grid containing atmospheric attenuation and radiation index (C) and a corresponding attenuation table ATTLUT. This table translates the emitted surface energy index into the sensor input energy index SI. The color lookup table is required to translate the sensor input into R, G, B display intensities. R, G, B colormaps can easily be indexed into intensity maps for a true IR sensor display.

This approach seems to be headed in the right direction for solving the problems of real-time IR scene rendering. Even with advances in computer technology and speed, it's likely some level of off-line calculation of quantized rendering solutions and look-up tables will be needed. This becomes more apparent as IR sensor technology matures into higher density, higher resolution, and more sensitive FPAs implementing special signal processing techniques.

THIRD GENERATION IR SENSOR TECHNOLOGY

As we move into the 21st century IR sensor technology will continue to grow and modeling and simulation of these new systems will become more complex. Efforts are ongoing to develop 3rd generation IR sensor technology in order to satisfy the requirements of future search and target acquisition systems. Basically, 3rd generation IR sensor technology will consist of large staring multispectral focal plane arrays and hyperspectral sensors with smart read-out electronics using feedback control from weapons system processors to optimize target acquisition. Justification for this development is to:

- Improve range performance
- Improve human/ATR interfaces
- Minimize performance degradation from weather and countermeasures
- Reduce cost/weight versus the current technology

The U.S. Army NVESD is currently developing large staring FPA on the order of 1280 x 960 pixels, with 18 μm pitch monolithically integrated with smart silicon readout.⁷ In comparison to 2nd generation technology, a 256 x 256 pixel FPA with 25 μm pitch is considered "state-of-the-art". Assuming F1 optics and an aperture diameter of 10 cm, this type FPA has an instantaneous field of view of about 0.25 mr, which results in approximately 0.25 meters of resolution at 1 km. Total field of view is approximately 3.7 degrees. A 1280 x 960 pixel array with 18 μm pitch can achieve 0.18 mr, resulting in 0.18 meters resolution at 1 km range. Total field of view is approximately 13 degrees x 10 degrees. With respect to modeling and simulation of these 3rd generation IR sensor systems, fidelity requirements are going to become a challenge.

In addition to the larger higher resolution sensors, these FPAs will be monolithically integrated with smart signal processing capable of temporal, polarization, and multispectral processing. Temporal processing is a technique used to sample an image as a function of time and extract the frequency components of fluctuating radiance. To do this a high sample frame rate on the order of hundreds of cycles per second is required.

This technique allows for characterization of objects with unique cyclic components, such as the main and tail rotor of a helicopter or the prop of an unmanned aerial vehicle (UAV). Another example of temporal processing is frame subtraction or moving target indication (MTI). This will allow detection of objects which are moving with respect to a stabilized background image.

Polarization signal processing allows for the suppression of background clutter. The approach is based on the difference in the polarization characteristics in the thermal IR from targets and from backgrounds. The phenomenology is different but the signal processing is very similar to the multispectral processing for two or three bands. Many man-made target surfaces are smooth relative to 5 or 10 μm , whereas many natural materials are correspondingly rough. Most paints are smooth in the IR band and are dielectric. Metals also tend to be smooth. They tend to be specular reflectors with polarized reflectances well described by the Fresnel equations. Polarization is a function of target surface geometry and view angle from the sensor to the target. Shallow view angles to horizontal target surfaces provide maximum polarization, so polarization is a likely candidate processing technique for clutter suppression in IR search and track systems.

Multispectral signal processing allows for the collection of data in several spectral bands nearly simultaneously and in near spatial registration. The emphasis of multispectral signal processing is somewhat different in the reflective (0.4 to 2.6 μm) and the thermal multispectral regions (3 to 5 and 8 to 12 μm). In the reflective region there is considerable variability because of the variable solar illumination, sun and view angle effects, atmospheric scattering, etc. In the thermal IR it is temperature variations caused by emissivity differences that are of interest in discriminating targets from background or targets from targets.

SUMMARY

As IR sensor development has progressed, so has modeling and simulation of these systems. It has been argued whether the detailed, deterministic approach or the more general statistical approach of modeling lends the most merit in the development of sensor systems. However, with the development of advanced IR systems, it's not hard to see the complexity and the challenges we face with modeling and simulation. Future system test and evaluation, analysis, and training will depend more and more on modeling and simulation; therefore, it is imperative we develop synthetic IR scenes with as much fidelity as possible in order to accurately model these advanced 3rd generation systems.

As we move from DIS and into the HLA world, the approaches taken in generating synthetic IR imagery must take into consideration the anticipated capabilities of 3rd generation systems. These systems will be able to perform autonomous target acquisition and recognition in addition to, or assisting the man-in-the-loop. It all boils down to being able to create the realistic "synthetic battlefield" for input into the sensor models in order to support real-time simulation with meaningful results.

REFERENCES

- 1) Passmore, R., et. al., Probability of Acquisition Analysis for an IRTGSM Seeker, U.S. Army Missile Command, technical report RE-82-15, 1982.
- 2) Passmore, R., et. al., Improvements in Infrared Seeker and Sensor Performance Modeling, U.S. Army Missile Command, technical paper, 1993.
- 3) Passmore, R., et. al., Incorporation of Background Clutter Effects into Performance Modeling, U.S. Army Missile Command, technical paper, 1993.
- 4) Lorenzo, M., et. al., Fidelity Requirements for EO Sensor Simulations, 1997 Spring Simulation Interoperability Workshop, Orlando, FL, 1997.
- 5) Lorenzo, M., et. al., DIS IR Simulation Models for Fidelity, Signatures, and Sensor – Atmosphere Effects, SPIE Proceedings of the DIS Systems Applications Conference, Orlando, FL, April 1995.
- 6) Baer, W., Real Time Scientific Rendering for General Sensor, 1997 Spring Simulation Interoperability Workshop, Orlando, FL, 1997.
- 7) Notes from discussions with DR. Pollard, Director of Technology, U.S. Army Night Vision and Electronic Sensors Directorate, Ft. Belvoir, VA, April 1997.