

AD_____

GRANT NUMBER DAMD17-97-1-7299

TITLE: Cataloging Differentially Expressed Sequence Tags from
Human Breast Cancer

PRINCIPAL INVESTIGATOR: Mark A. Watson, M.D.

CONTRACTING ORGANIZATION: Washington University
St. Louis, Missouri 63110-1076

REPORT DATE: September 1998

TYPE OF REPORT: Annual

PREPARED FOR: U.S. Army Medical Research and Materiel Command
Fort Detrick, Maryland 21702-5012

DISTRIBUTION STATEMENT: Approved for public release;
distribution unlimited

The views, opinions and/or findings contained in this report are those of the author(s) and should not be construed as an official Department of the Army position, policy or decision unless so designated by other documentation.

DTIC QUALITY INSPECTED 4

REPORT DOCUMENTATION PAGE

Form Approved
OMB No. 0704-0188

Public reporting burden for this collection of information is estimated to average 1 hour per response, including the time for reviewing instructions, searching existing data sources, gathering and maintaining the data needed, and completing and reviewing the collection of information. Send comments regarding this burden estimate or any other aspect of this collection of information, including suggestions for reducing this burden, to Washington Headquarters Services, Directorate for Information Operations and Reports, 1215 Jefferson Davis Highway, Suite 1204, Arlington, VA 22202-4302, and to the Office of Management and Budget, Paperwork Reduction Project (0704-0188), Washington, DC 20503.

| | | | | | |
|---|--|---|--|---|--|
| 1. AGENCY USE ONLY <i>(Leave blank)</i> | | 2. REPORT DATE September 1998 | | 3. REPORT TYPE AND DATES COVERED Annual (1 Sep 97 - 31 Aug 98) | |
| 4. TITLE AND SUBTITLE Cataloging Differentially Expressed Sequence Tags from Human Breast Cancer | | | | 5. FUNDING NUMBERS DAMD17-97-1-7299 | |
| 6. AUTHOR(S) Mark A. Watson, M.D. | | | | 8. PERFORMING ORGANIZATION REPORT NUMBER | |
| 7. PERFORMING ORGANIZATION NAME(S) AND ADDRESS(ES) Washington University St. Louis, Missouri 63110-1076 | | | | | |
| 9. SPONSORING / MONITORING AGENCY NAME(S) AND ADDRESS(ES) U.S. Army Medical Research and Materiel Command Fort Detrick, Maryland 21702-5012 | | | | 10. SPONSORING / MONITORING AGENCY REPORT NUMBER | |
| 11. SUPPLEMENTARY NOTES | | | | | |
| 12a. DISTRIBUTION / AVAILABILITY STATEMENT Approved for public release; distribution unlimited | | | | 12b. DISTRIBUTION CODE | |
| 13. ABSTRACT <i>(Maximum 200 words)</i> Using substantial modifications of the differential display polymerase chain reaction technique, we have successfully implemented a moderate-throughput method for isolating and directly sequencing novel cDNA fragments. An initial set of these cDNA fragments correspond to mRNAs that are differentially expressed among five different human breast tumor cell lines. In this report, we summarize the strategy used to create a 'catalog' of approximately 150 of these Differentially Expressed Sequence Tags (DESTs). An outline for work to continue in the second year of this award includes expression analysis of already isolated tags via the creation of a cDNA array and further identification of additional, novel sequence tags from microdissected human breast tumor specimens. | | | | | |
| 14. SUBJECT TERMS Breast Cancer Gene Expression, Gene Discovery, Expressed Sequence Tag, Tumor Marker | | | | 15. NUMBER OF PAGES 16 | |
| 17. SECURITY CLASSIFICATION OF REPORT Unclassified | | | | 16. PRICE CODE | |
| | | | | 20. LIMITATION OF ABSTRACT Unlimited | |
| 18. SECURITY CLASSIFICATION OF THIS PAGE Unclassified | | 19. SECURITY CLASSIFICATION OF ABSTRACT Unclassified | | | |

19990614 079

Table of Contents

| | |
|---------------------------------|----|
| Front Cover | 1 |
| Standard Form 298 | 2 |
| Foreword | 3 |
| Table of Contents | 4 |
| Introduction | 5 |
| Experimental Methods | 6 |
| Results and Discussion | 8 |
| Recommendations | 8 |
| Conclusions | 9 |
| References | 10 |
| Appendix A - Figures and Tables | 12 |

Introduction

The clinical course of breast cancer is highly variable between patients, particularly when it is discovered at its earliest stage. For example, of patients with newly diagnosed Stage I breast cancer, approximately 20% will subsequently develop metastatic disease within five years while 80% will remain disease free after resection alone (1). Because of the controversial cost and morbidity to total benefit ratio of treating all Stage I breast cancer patients with aggressive chemotherapy, an enormous emphasis has been placed on the development of biological markers to better assist in treatment planning and prognosticating the clinical course of breast cancer patients (2). In addition to traditional analyses of tumor size, lymph node involvement, hormone receptor function, and nuclear grade, a plethora of molecular markers have been proposed as prognostic tools (3-7). The biological rationale supporting the clinical utility of many of these markers is that the evolution of breast cancer is accompanied by multiple changes in gene expression and that quantification of these changes can provide predictive information about the clinical course of individual tumors. However, while analysis of individual gene expression has been shown to have predictive value within single studies, there is no clear consensus to suggest that analysis of any one gene or gene product has independent predictive power (8).

As our understanding of both the human genome and the molecular genetic basis of cancer has expanded over the past five years, it is now believed that a broader examination of global patterns of gene expression may be a more sensitive and specific method for characterizing tumors at the molecular level. A number of technical advances have made such an approach possible. Catalogs of thousands of expressed genes in the form of Expressed Sequence Tags (ESTs) are now available for analysis (9-11). Many of these catalogs are derived from tumor tissue sources, including breast cancer. The availability of this sequence information enables investigators to identify potential genes that contribute to the pathogenesis of cancer and that may ultimately serve as prognostic markers. A second technical advance is the ability to simultaneously and quantitatively measure expression of multiple genes using cDNA arrays (12-14). This experimental approach allows for the analysis of global patterns of gene expression rather than traditional methods that examine expression 'one gene at a time' (15).

While both of these strategies represent important technical advances, neither has been specifically directed toward addressing clinical problems. For example, EST catalogs from tumor sources (such as breast cancer) contain sequences that are neither tumor-specific nor cell-specific. Therefore, identification of clinically relevant gene sequences will require considerable filtering of this sequence information. Furthermore, the EST sequences obtained from tumor specimens contain no accompanying information with regard to the tumor or patient from which they were obtained. For this reason, it will be impossible to use this sequence information to correlate patterns of gene expression with any clinically or pathologically significant parameters. While still in its infancy, the development of cDNA arrays for the multiplex analysis of gene expression has emphasized the placement of large numbers of randomly chosen cDNAs in an array to build a comprehensive screen of gene expression. Without a rationale-based approach for selecting gene sequences to place in the probe array, a very large array will be needed and the majority of patterns of expression detected will be irrelevant to individual tumor phenotypes.

Our interest is in identifying quantitative changes in gene expression that correlate with significant clinical parameters of human breast cancer. By identifying a finite set of these changes, we believe that the patterns of gene expression ('expression fingerprints') of individual tumors will be a sensitive and specific diagnostic tools for assisting in prognosis and therapeutic management of breast cancer patients. We have previously demonstrated that, using several

modifications of the differential display polymerase chain reaction technique (DDPCR), we are able to create a high throughput system that can rapidly identify Differentially Expressed Sequence Tags (DESTs) from primary human breast tumors (16). These DESTs are cDNA fragments corresponding to mRNAs that are differentially expressed in breast tumors as compared to patient-matched normal breast tissue. A catalog of these sequences would provide a potential list of new molecular markers for phenotyping breast tumors, particularly if they are correlated with clinical information about the tumor and patient from which they were derived (16). In fact, we have already demonstrated that one DEST obtained in this manner is a potentially useful new molecular marker for breast cancer (17).

In this report, we describe our progress in adopting our preliminary work toward the creation of a breast tumor DEST library, similar in scope to EST libraries that are now in existence, but with added clinical relevance to human breast cancer. Thus far, we have optimized protocols using five different human breast tumor cell lines to isolate 150 DEST fragments. Having demonstrated the feasibility of this approach using human breast tumor cell lines, we are now in the process of analyzing a small set of well defined, microdissected, primary human breast tumors. We believe the results of this work will ultimately define a set of gene sequences whose pattern of expression could collectively define a breast tumor with regard to its metastatic potential, therapeutic vulnerability, and prognostic significance to the patient.

Experimental Methods

The differential display polymerase chain reaction (DDPCR) and RNA fingerprinting have been used extensively to isolate genes that are differentially expressed between different cell and tissue types (18, 19). In the DDPCR technique, messenger RNA (mRNA) is isolated from multiple cell sources and reverse transcribed to produce a set of cell-specific complementary DNAs (cDNAs). These cDNAs are then used as template for a polymerase chain reaction (PCR) at low stringency annealing conditions. Polymerization is primed with one oligonucleotide of an arbitrarily defined sequence, ten nucleotides in length (10mer), and a T₁₁MN oligonucleotide (M=A,G,C; N=A,C,G,T). In the presence of radiolabeled nucleotides, the resulting randomly primed polymerization products theoretically represent a subset of expressed mRNAs from each cell population. Each PCR reaction is run side by side on an acrylamide sequencing gel and products unique to one cell type are identified, isolated, and subcloned for further study. We have made a number of innovative modifications to this technique to increase the yield of truly differentially expressed sequences that are isolated, and to allow for the rapid, high-throughput analysis of these sequences without the time- and labor-intensive process of subcloning. Using this improved method, we have identified differences in gene transcription among five different human breast tumor cell lines (**Table I**). **Figure 1** outlines this procedure.

Indicated cell lines were obtained from the American Type Culture Collection and grown in media formulations as recommended by the supplier. Approximately 1×10^6 cells from each cell line were isolated in duplicate. From each pair of cell samples, 5 μ g of total RNA was purified, treated with RNase-free DNase, reverse transcribed, degraded with RNaseH and DNase-free RNase, and purified by spin chromatography. After considerable experimentation with different cDNA synthesis and purification schemes, we found that these steps of first strand cDNA preparation were absolutely necessary to produce reliable and reproducible DDPCR displays.

Synthesized cDNA pools from each cell line were subjected to the DDPCR technique as described above and previously (18, 19) except for several notable changes. First, we investigated the use of several different ³²P radiolabeled 'Tmer' oligonucleotides to generate labeled PCR products. We compared a set of four degenerate T₁₁VN oligonucleotides (where V is a mix of A, G, and C bases and N is either A, C, G, or T), a set of three specific T₁₁N oligonucleotides, and a set of six (of a total possible of 12) specific T₁₁NN oligonucleotides. After optimizing annealing temperatures and cycling conditions for each primer set, we concluded that the set of four degenerate T₁₁VN oligonucleotides produced the most specific and reliable display pattern. Each of the T₁₁VN oligonucleotides also contained a 10 nucleotide 5' 'anchor' sequence corresponding to the T7 RNA polymerase promoter for the purposes of secondary amplification of isolated PCR fragments. End-labeling oligonucleotides with T4 polynucleotide kinase (as opposed to incorporation of ³²P-labeled dCTP) produced superior results in terms of pattern reproducibility and theoretically ensured that all labeled (and hence visualized) PCR products were the result of priming from mRNA polyA tails. The second (10mer) primer employed in the PCR reaction was an arbitrary, ten nucleotide sequence with an additional ten nucleotide 5' 'anchor' sequence corresponding to the M13 origin of replication sequence. A number of different arbitrary sequences were incorporated in the '10mer' primer, all of which were devoid of palindromic sequences and maintained a G/C content of 60%. Although the pattern of amplified fragments differed using each '10mer' primer (see **figure 2**), the overall performance of the reactions were not significantly affected by primer sequence composition. After considerable trial, a set of four degenerate 'Tmer' and seven '10mer' primers were established for all future work (**Table II**). Finally, conditions were optimized such that reactions could be reliably performed in a 10 µl volume and loaded directly on a 4% denaturing acrylamide sequencing gel for preparative analysis.

For one given experiment, duplicate first strand cDNA reactions were performed with each human breast tumor cell line as described above. A single display experiment involved amplification and electrophoresis of 10 duplicated pairs of cDNA samples using a single 'Tmer' primer in combination with three different '10mer' oligonucleotides (10x1x3=30 total samples). Each experiment was repeated in triplicate to verify the reproducibility of the display pattern. A representative display is shown in **figure 2**. Experiments were then repeated for each of the seven '10mer' primers permuted with each of the four 'Tmer' sequences described above. Unlike other studies described to date, potentially relevant DEST fragments were selected for reamplification, sequencing, and entry into the DEST database using a set of strict criteria. These criteria were: i) Fragment absent (loss of expression) in duplicate cDNA reactions from at least two different cell lines or ii) Fragment present (gain of expression) in duplicate cDNA reactions from at least one different cell line. In addition, fragments chosen for further analysis could not be present in the same cell line cDNA reactions that employed two different '10mer' primers. This criteria ensured that the amplified band was synthesized by the priming of both the specific '10mer' primer and specific 'Tmer', rather than the 'Tmer' alone. Bands resulting from 'Tmer'-only priming events are not candidates for direct PCR sequencing since their ends are symmetrical.

Candidate bands were excised from their acrylamide sequencing gel, eluted, and reamplified in a standard polymerase chain reaction using the original '10mer' and 'Tmer' oligonucleotide primers employed for DDPCR. We examined several other strategies that employed nested primer approaches to affect secondary amplification, but found that this was unnecessary. Reamplified bands were quantitated and qualitatively assessed by agarose gel

electrophoresis (**figure 3**). Approximately 20 ng of each secondarily amplified PCR product was subjected to cycle sequencing using a ³²P end-labeled oligonucleotide corresponding to the '10mer' used for the original DDPCR reaction. We again examined the use of nested sequencing primers to enhance sequencing read, but found that this strategy did not improve results.

Isolated sequence information was compared to the NCBI Genbank database (20, 21) to determine whether a DEST fragment represented a previously characterized gene, and was then entered into a computer database designed in Microsoft *Access* format (**figure 4**).

Results and Discussion

Using the methodology described above, we have attempted to isolate gene sequences that are differentially expressed among five different human breast tumor cell lines. **Figure 2** demonstrates a sample result from the numerous differential display experiments that we have performed over the past year. We have identified 148 PCR fragments that are reproducibly and differentially present among the cell lines tested. **Figure 3** demonstrates a sample result from isolation and secondary amplification of a small set of these fragments. Overall, approximately 90% of bands identified and isolated resulted in secondary amplification products. We have used a direct cycle sequencing approach to sequence and identify the first set of these secondarily amplified products. Thus far, approximately 70% of products are amenable to direct sequencing. **Figure 5** demonstrates sample sequencing reads from several of these PCR products. Although the overall quality of the sequence is poor, we can routinely read 50-100 nucleotides of sequence with ~95% accuracy. This is sufficient sequence information to uniquely identify the expressed gene and to design tertiary, gene-specific primers for future use. Each sequenced DEST has been entered into a database that, upon further maturation, will be made available to the public realm via internet access. **Figure 4** demonstrates a sample data entry form in this database. Although we are still only beginning to analyze sequence data, **Table III** list several differentially expressed genes that we have identified thus far. The fact that at least three of these sequences have already been identified in independent experimental runs suggests that the sequences that we are isolating are not artifacts of the DDPCR assay.

Recommendations

In the original proposed plan of research, the first six months of work were to be devoted to creating a library of Differentially Expressed Sequence Tags (DESTs) from 12 initial cases of human breast tumor/normal pairs. To simplify the system in which we intended to identify and correct technical problems, we have chosen to focus on human tumor cell lines that can provide a more abundant and controlled source of RNA. Furthermore, despite our familiarity with the DDPCR approach, we encountered a number of technical difficulties that required re-optimization of protocols. As such, Task 1 has been extended through month 12 of the proposal. Also in the original plan, months 7-12 were to be devoted to establishing an initial cDNA array of DEST sequences and developing protocols to quantitate gene expression using radiolabeled cDNAs from 2-5 sets of human tumor/normal tissue pairs. Because of the delay in establish a set of candidate probe sequences, this task has not been initiated.

In view of our current progress and stated aims in the original proposal, we propose the revised time line for this study:

Task 1: Months 13-14: Complete sequence analysis and identification of 148 sequences derived from human breast tumor cell lines. Optimize remainder of direct cycle sequencing protocol for secondarily amplified PCR products.

Task 3: Months 15-24: Prepare duplicate RNAs and first strand cDNAs from 15 cases of histopathologically matched breast tumors using laser-mediated microdissection. Use these cDNAs to isolate at least 200 different DEST sequences with 40 combinations of primer pairs. Enter DEST sequences, clinical data, and pathology data into DEST database. The objective will be to use the now established experimental approach to identify molecular variability among otherwise histologically indistinguishable breast tumors and correlate these differences to other significant clinical variables.

Task 4: Months 15-20: Synthesize RNA standards. Create preliminary array of 44 DEST sequences identified in **Task 1**. Test hybridization conditions and quantification of gene expression using radiolabeled cDNAs from the original five breast cell lines used in **Task 1**. Identify technical problems and modify protocol. *Evaluate alternate approaches to quantitate DEST expression levels in tumor samples such as multiplex PCR assays using semi-quantitative or quantitative (real-time) assay formats.*

Task 5: Months 21-24: Use assay format established in **Task 4** to quantitate DEST gene expression in 20 sets of primary human breast tumors. Enter patterns of expression, clinical data, and pathology data into DEST database.

Conclusions:

Although progress has been slower than anticipated due to a number of technical difficulties, we believe that the current study may still result in a much larger effort directed at defining a complete set of diagnostic expressed sequence tags. For example, if the results of these experiments continue to be encouraging, we would consider using even newer technical advances to display a more complete set of expressed sequences and to create larger arrays of DEST probes (22). We would also expand our catalog of DEST sequences to include tumor specimens with accompanying patient data describing treatment response, disease-free survival, and overall survival. Just as we are attempting to correlate DEST expression with basic clinical and pathological data in this proposal, we could eventually correlate expression of these sequences with this more clinically pertinent data. Ultimately, we believe that this approach can be used to create a nearly complete set of genetic markers whose pattern of expression would define the clinical course and therapeutic vulnerability of individual patient tumors. Obviously, such a diagnostic tool would have tremendous impact on the diagnosis and treatment of breast cancer patients.

References

- 1) Elledge, R.M., McGuire, W.L. Prognostic Factors and Therapeutic Decisions in Axillary Node-Negative Breast Cancer. *Ann. Rev. Med.* **44**:201-210 (1993).
- 2) Gasparini, G., Pazza, F., Harris, A.L. Evaluating the Potential Usefulness of New Prognostic and Predictive Indicators in Node-Negative Breast Cancer Patients. *J. Natl. Cancer Inst.* **85**:1206-1219 (1993).
- 3) Lippman, M.E., Porter-Jordan, K. Overview of the Biologic Markers of Breast Cancer. *Hem. Onc. Clin. N. Am.* **8**:73-100 (1994).
- 4) Mansour, E.G., Ravdin, P.M., Dressler, L. Prognostic Factors in Early Breast Carcinoma. *Cancer* **74**:381-400 (1994).
- 5) Paik, S., Burkhard, E., Lippman, M.E. Clinical Significance of *erbB2* Protein Overexpression. *Cancer Treat. Res.* **61**: 181-191 (1992).
- 6) Harris, A.L. p53 expression in human breast cancer. *Advances in Cancer Research.* **59**: 69-88 (1992).
- 7) Weinstat-Saslow, D., *et. al.* Overexpression of Cyclin D mRNA Distinguishes Invasive and In Situ Breast Carcinomas from Non-Malignant Lesions. *Nature Medicine* **1**: 1257-1260 (1995).
- 8) Ravdin, P.M., Chamness, G.C. The *c-ErbB-2* Proto-Oncogene as a Prognostic and Predictive Marker in Breast Cancer: a Paradigm for the Development of Other Macromolecular Markers - a Review. *Gene* **159**: 19-27 (1995).
- 9) Adams, M.D., *at. al.* Initial Assessment of Human Gene Diversity and Expression Patterns Based Upon 83 Million Nucleotides of cDNA Sequence. *Nature* **377S**: 3-174 (1995).
- 10) Weinstock, K.G., *et. al.* cDNA Sequencing: A Means of Understanding Cell Physiology. *Curr. Opin. Biotech.* **5**: 599-603 (1994).
- 11) Matsubara, K., and Okubo, K. Identification of New Genes by Systematic Analysis of cDNAs and Database Construction. *Curr. Opin. Biotech.* **4**: 672-677 (1993).
- 12) Schena, M., Shalon, D., Davis, R.W., Brown, P.O. Quantitative Monitoring of Gene Expression Patterns with a Complementary DNA Microarray. *Science* **270**: 467-470 (1995).
- 13) Nguyen, C., *et. al.* Differential Gene Expression in the Murine Thymus Assayed by Quantitative Hybridization of Arrayed cDNA Clones. *Genomics.* **29**: 207-216 (1995).

- 14) Bernard, K., *et. al.* Multiplex Messenger Assay: Simultaneous, Quantitative Measurement of Expression of Many Genes in the Context of T Cell Activation. *Nucleic Acids Res.* **24**: 1435-1442 (1996).
- 15) Pennisi, E. From Genes to Genome Biology (Research News) *Science* **272**: 1736-1738 (1996).
- 16) Watson, M.A., Fleming, T.P. Isolation of Differentially Expressed Sequence Tags from Human Breast Cancer. *Cancer Research* **54**: 4598-4602 (1994).
- 17) Watson, M.A., Fleming, T.P. Mammaglobin, A Mammary-Specific Member of the Uteroglobin Gene Family, is Overexpressed in Human Breast Cancer *Cancer Research* **56**: 860-865 (1996).
- 18) Liang, P., Pardee, A.B. Recent advances in differential display. *Curr. Opin. Imm.* **7**: 274-280 (1995).
- 19) McClelland, M., Mathieu-Daude, F., Welsh, J. RNA fingerprinting and differential display using arbitrarily primed PCR. *Trends in Genetics.* **11**: 242-246 (1995).
- 20) Benson, D.A., Boguski, M., Lipman, D.J., Ostell J. GenBank. *Nucleic Acids Res.* **24**: 1-5 (1996).
- 21) Altschul, S.F., Gish, W., Miller, W., Myers, E.W., Lipman, D.J. Basic local alignment search tool. *J. Mol. Biol.* **215**: 403-410 (1990).
- 22) Jacobs, J.W., Fodor, S.P.A. Combinatorial Chemistry - Applications of Light-Directed Chemical Synthesis. *Trends Biotech.* **12**: 19-25 (1994).

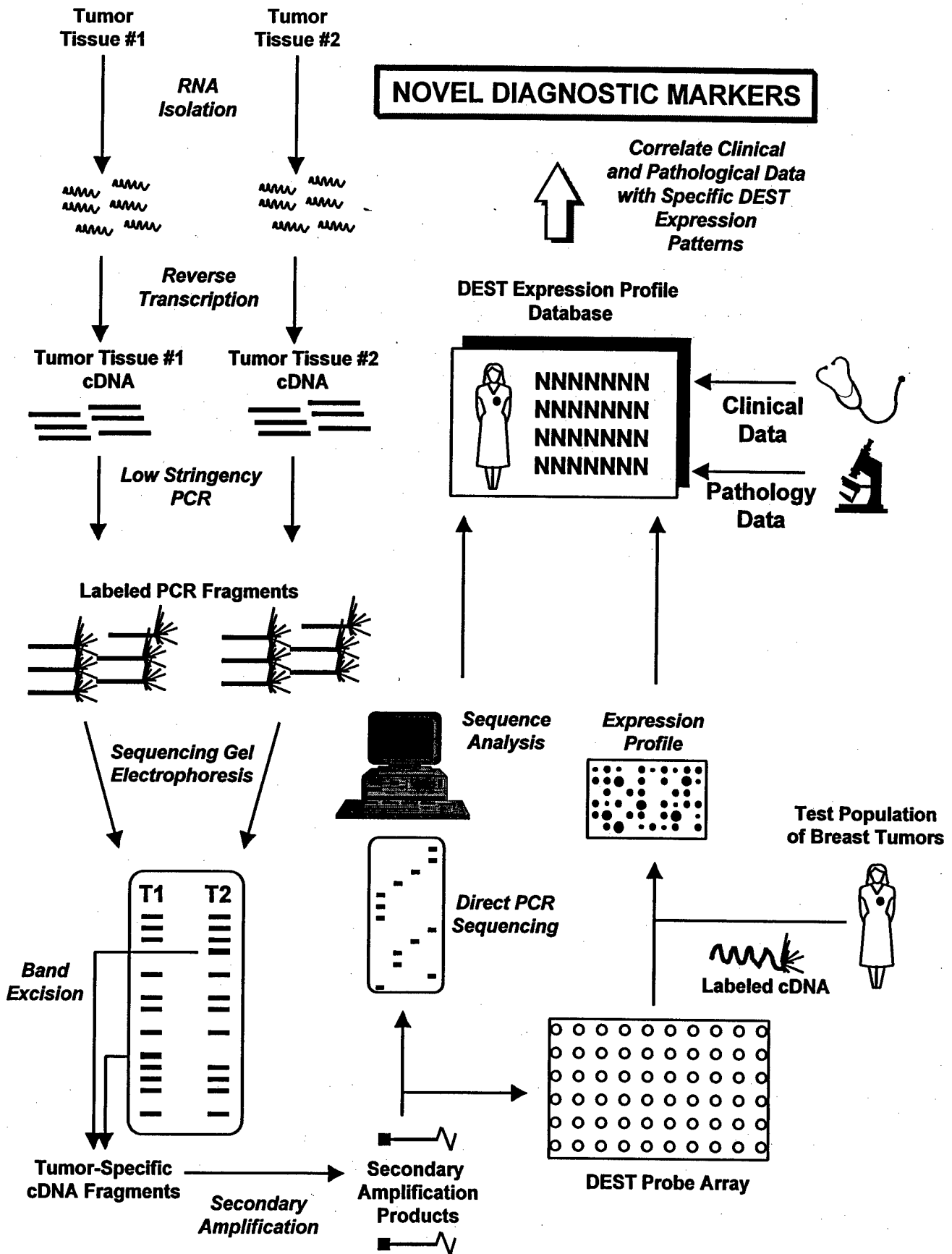

FIGURE 1: Scheme for Cataloging DEST Expression Patterns from Human Breast Cancer

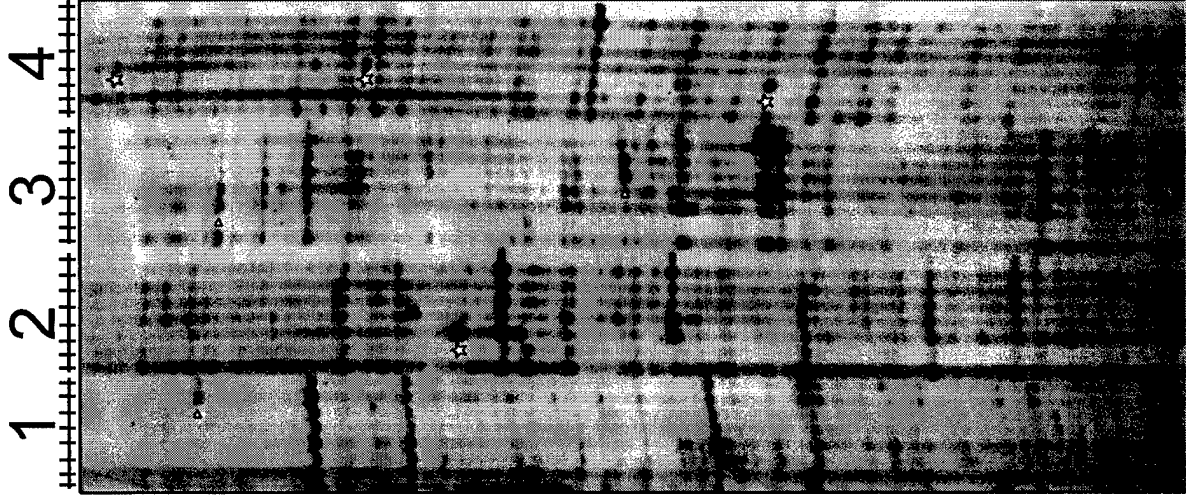
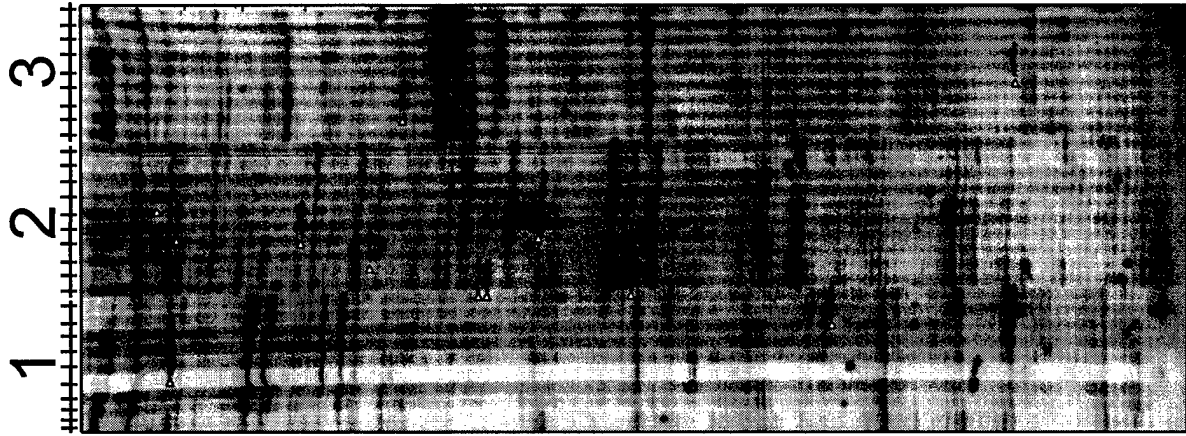

FIGURE 2: Representative Differential Display from Human Breast Carcinoma Cell Lines. cDNAs were prepared from four or five different cell lines (Table I) in duplicate and subjected to differential display analysis using a single T₁₁MN labeled primer and different 10mer primers (1-3 and 1-4) as described in the text. Several fragments that were isolated for further analysis are indicated by arrowheads. Note that in earlier experiments (*right panel*), technical difficulties produced many more artifactual bands that were not reproduced in duplicate cDNAs (*stars*).

1 2 3 4 5 6 7 8 9 0 1 2 3 4 5 6 7 8 9 0
 1 1 1 1 1 1 1 1 1 1 1 1 1 1 1 2

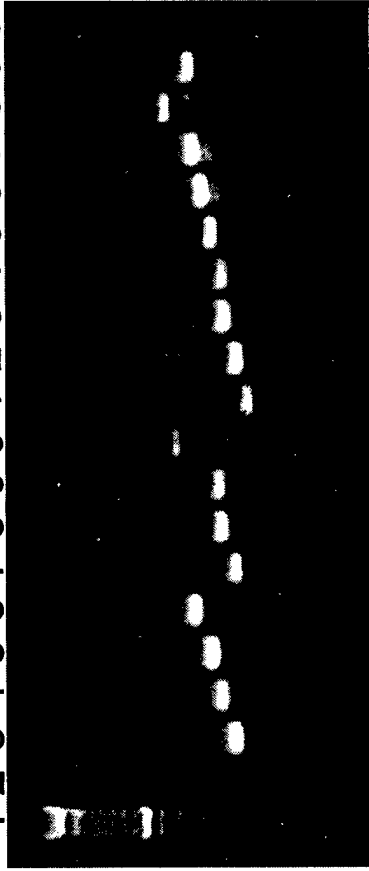

FIGURE 3: Representative Reamplification Result from Isolated DEST fragments. A 2% agarose gel electrophoresis analysis of 100 bp molecular weight marker (*lane 1*) and 18 reamplification products (*lane 3-20*). Note that 17 of 18 fragments (94%) in this experiment were successfully reamplified. Also note that the size of each fragment corresponds to the size of the original DEST band isolated from the display gel.

DESTS Form

DEST Number: 1 Sequence Gel #: 40-S3

Date Entered: 5/26/98

DDPCR Gel #: 40-8

Forward Primer: MF2

Reverse Primer: TTT11G

Size (bp): 400

Sequence ID: Human mRNA ATP Synthetase B-subunit

Sequence: TAAATCTCAGCCATTCCAGGTGGCTGAGGTCTTCACAGGTGATA
TGGGGAAAGCTGGTAACCCCT

Expression Pattern: Baseline Down-Regulated Up-Regulated Ambiguous

cDNA #: 5

Comments:

Record: 1 of 10

FIGURE 4: Sample Data Entry Form from DEST database. This figure shows the data entry form for each DEST sequence identified. Other forms are accessible for entering information about each cDNA pool used for display experiments.

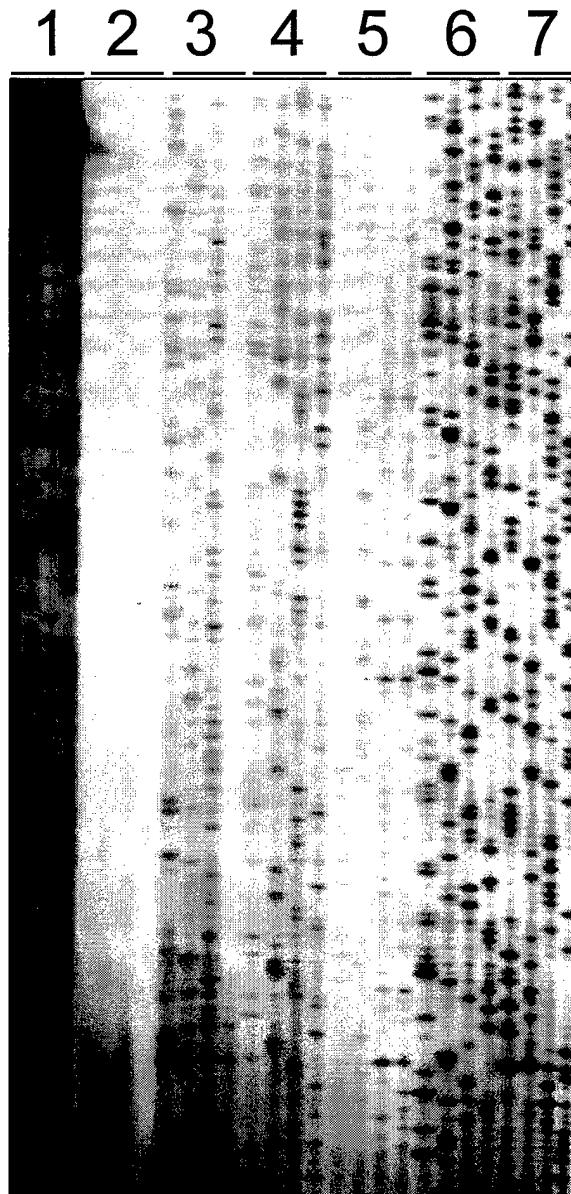

FIGURE 5: Representative Sequence Analysis of Reamplified DEST fragments. Seven secondarily amplified DEST fragments were subjected to direct cycle sequencing as described in the text. Note that some fragments yielded very good sequence (1, 6, and 7), others produced poor sequencing reads (3, 4), and others produced no readable sequence at all (2, 5). Thus far, approximately 70% of isolated fragments have provided sufficient sequencing information to positively identify fragments as either previously characterized or novel gene products.

T47D
MCF-7
MDA-MB361
MDA-MB415
MDA-MB468

Table I. Human Breast Carcinoma Cell Lines Used for Generating a DEST catalog for Human Breast Cancer.

| Primer Name | Sequence |
|----------------------|-------------------------------|
| T7T ₁₁ VA | 5'-CACTATAGGGTTTTTTTTTTTVA-3' |
| T7T ₁₁ VC | 5'-CACTATAGGGTTTTTTTTTTTVC-3' |
| T7T ₁₁ VG | 5'-CACTATAGGGTTTTTTTTTTTVG-3' |
| T7T ₁₁ VT | 5'-CACTATAGGGTTTTTTTTTTT-3' |
| MF1 | 5'-CAGTCACGACGACCGCTTGT-3' |
| MF2 | 5'-CAGTCACGACAGGTGACCGT-3' |
| MF3 | 5'-CAGTCACGACTCCGGCTGAA-3' |
| MF4 | 5'-CAGTCACGACGCTGCGTGAT-3' |
| MF5 | 5'-CAGTCACGACGGTGCCTGAA-3' |
| MF6 | 5'-CAGTCACGACCTGCGGTGAT-3' |
| MF7 | 5'-CAGTCACGACCGGCTGTGAA-3' |

Table II. Primer Sequences Used for Differential Display PCR.

| DEST # | Sequence ID | Cell Line Expression Pattern | | | | |
|--------|--------------------------------|------------------------------|------|-------|-------|-------|
| | | T47D | MCF7 | MB415 | MB468 | MB361 |
| 1 | ATP Synthetase β Subunit | - | - | +++ | - | - |
| 2 | ATP Synthetase β Subunit | + | + | +++ | + | + |
| 3 | AA505271 | - | - | +++ | - | - |
| 4 | Ferritin | - | - | +++ | - | - |
| 5 | AA992438 | +++ | +++ | +++ | - | +++ |
| 6 | AA406625 | +++ | - | - | - | - |
| 7 | Ribosomal Protein L22 | +++ | - | - | - | - |
| 8 | ATP Synthetase β Subunit | - | - | +++ | - | - |
| 9 | Amplaxin | + | + | +++ | + | + |
| 10 | Amplaxin | + | + | +++ | + | + |

Table III. Representative Selection of DEST Sequences Isolated that Correspond to Previously Known Sequences. Qualitative expression of each DEST in five different human breast tumor cell lines is also indicated.