

AD

TECHNICAL REPORT ARCCB-TR-99007

COMPUTERIZED ULTRASONIC GAUGING

ROBERT W. REED
A. ABBATE
J. FRANKEL

19990615 014

MAY 1999



US ARMY ARMAMENT RESEARCH,
DEVELOPMENT AND ENGINEERING CENTER
CLOSE COMBAT ARMAMENTS CENTER
BENÉT LABORATORIES
WATERVLIET, N.Y. 12189-4050



APPROVED FOR PUBLIC RELEASE; DISTRIBUTION UNLIMITED

STIC QUALITY INSPECTED 1

DISCLAIMER

The findings in this report are not to be construed as an official Department of the Army position unless so designated by other authorized documents.

The use of trade name(s) and/or manufacturer(s) does not constitute an official endorsement or approval.

DESTRUCTION NOTICE

For classified documents, follow the procedures in DoD 5200.22-M, Industrial Security Manual, Section II-19, or DoD 5200.1-R, Information Security Program Regulation, Chapter IX.

For unclassified, limited documents, destroy by any method that will prevent disclosure of contents or reconstruction of the document.

For unclassified, unlimited documents, destroy when the report is no longer needed. Do not return it to the originator.

REPORT DOCUMENTATION PAGE

Form Approved
OMB No. 0704-0188

Public reporting burden for this collection of information is estimated to average 1 hour per response, including the time for reviewing instructions, searching existing data sources, gathering and maintaining the data needed, and completing and reviewing the collection of information. Send comments regarding this burden estimate or any other aspect of this collection of information, including suggestions for reducing this burden, to Washington Headquarters Services, Directorate for Information Operations and Reports, 1215 Jefferson Davis Highway, Suite 1204, Arlington, VA 22202-4302, and to the Office of Management and Budget, Paperwork Reduction Project (0704-0188), Washington, DC 20503.

1. AGENCY USE ONLY (Leave blank)	2. REPORT DATE May 1999	3. REPORT TYPE AND DATES COVERED Final	
4. TITLE AND SUBTITLE COMPUTERIZED ULTRASONIC GAUGING		5. FUNDING NUMBERS AMCMS No. 6111.01.91A1.1	
6. AUTHOR(S) Robert W. Reed (East Stroudsburg University, East Stroudsburg, PA), A. Abbate*, and J. Frankel			
7. PERFORMING ORGANIZATION NAME(S) AND ADDRESS(ES) U.S. Army ARDEC Benet Laboratories, AMSTA-AR-CCB-O Watervliet, NY 12189-4050		8. PERFORMING ORGANIZATION REPORT NUMBER ARCCB-TR-99007	
9. SPONSORING / MONITORING AGENCY NAME(S) AND ADDRESS(ES) U.S. Army ARDEC Close Combat Armaments Center Picatinny Arsenal, NJ 07806-5000		10. SPONSORING / MONITORING AGENCY REPORT NUMBER	
11. SUPPLEMENTARY NOTES Submitted to <i>Research in Nondestructive Evaluation</i> , A Journal of the American Society for Nondestructive Testing. *Current Address: Textron Systems Division, 201 Lowell Street, Wilmington, MA 01887.			
12a. DISTRIBUTION / AVAILABILITY STATEMENT Approved for public release; distribution unlimited.		12b. DISTRIBUTION CODE	
13. ABSTRACT (Maximum 200 words) A high-precision ultrasonic gauging system has been designed and implemented for use on a CNC lathe. The system uses a PC along with a number of plug-in cards to generate, receive, and process ultrasonic signals. The system has been reliably used both during and after machining operations. It is capable of simultaneous measurement of wall thickness, runout, outer diameter radius, inner diameter radius, and concentricity of the inner diameter and outer diameter. Data densities of 2000 measurements per revolution of all parameters can be achieved. Data can be acquired at lathe spindle speeds that keep the outside part surface moving at less than about 2000 surface feet per minute. A real-time, pseudo-color, image of the wall thickness is provided during operation. The system can receive setup and operational instructions from the lathe CNC so that operation can be accomplished with very little operator involvement.			
14. SUBJECT TERMS Ultrasonics, Gauging, Thickness Measurements, Wall Thickness, Gun Tubes			15. NUMBER OF PAGES 20
			16. PRICE CODE
17. SECURITY CLASSIFICATION OF REPORT UNCLASSIFIED	18. SECURITY CLASSIFICATION OF THIS PAGE UNCLASSIFIED	19. SECURITY CLASSIFICATION OF ABSTRACT UNCLASSIFIED	20. LIMITATION OF ABSTRACT LIT

TABLE OF CONTENTS

	<u>Page</u>
ACKNOWLEDGEMENTS	ii
INTRODUCTION.....	1
GAUGING SETUP ON A LATHE	1
Practical Considerations.....	1
Ultrasonic Measurement Issues.....	5
ULTRASONIC INSTRUMENTATION.....	6
TRANSDUCER AND SQUIRTER CONSIDERATIONS.....	10
FLUID COUPLANT	11
GAUGING ACCURACY	11
Limitations Due to Ultrasonic System	11
Limitations Due to Transducer Mounting.....	12
RESULTS.....	13
CONCLUSIONS	17
REFERENCES.....	18

LIST OF ILLUSTRATIONS

1. Transducer/squitter positioned on lathe relative to part.....	2
2. Part-transducer arrangement with relevant dimensions	2
3. Times between echoes from part surfaces shown in Figure 2.....	3
4. Basic gauging system schematic diagram	6
5. Shaded image of the ID radii.....	14
6. Data from one of the many scans comprising Figure 5.....	15
7. Lands and grooves from an uneroded tube.....	16
8. Lands and grooves from an eroded tube.....	17

ACKNOWLEDGEMENTS

We express our appreciation to Bryon Knight, Jeffrey Braunstein, Fred Pfindel, and William C. Korman for their help in the course of this work.

INTRODUCTION

Our technique for making rapid and accurate dimensional measurements (with computerization) of tubes in a lathe is described herein. The results include accumulation, processing, and real-time presentation of data for gauging on a lathe during or after cutting operations. This requires a measure of sophistication and presents challenges, but the rewards are greater than those encountered when using ultrasonic thickness gauges employing hand-held contact transducers. Even though the machining environment is often dirty, it can be adapted to provide appropriate transducer mounts with calibrated motion capability and methods for reliably coupling the ultrasonic beam to the part of interest. We describe here an ultrasonic system that was developed to overcome the limitations of many ultrasonic thickness measuring units. Much of the work to date has not required that data be taken simultaneously with cutting operations. However, data taken during cutting operations has been successfully demonstrated with no observable detriment to the ultrasonic measurement accuracy (ref 1).

Several quantities are of interest, including wall thickness and radius of the tube for the inside and outside surfaces (ID and OD) and concentricity of the inside and outside cylindrical surfaces. High data density allows realistic mapping of all of these, as needed. Wall thickness measurements are the most readily obtained with high accuracy. The accuracy of the other parameters depends on knowledge of the precise location of the ultrasonic transducer with respect to the lathe centerline. The ultrasonic measurements of wall thickness require measurement of the time delay between echoes reflected from outside and inside surfaces and knowledge of the speed of sound in the material being gauged. Measurements of OD radius (or runout) require measurement of the time for round-trip travel of an ultrasonic pulse from the transducer to the part and back through a coupling fluid, and the velocity of sound in the fluid. The issues involved in obtaining the desired information on a part running in a lathe and the methods used are discussed below.

GAUGING SETUP ON A LATHE

Practical Considerations

Since a majority of lathe cutting operations employ cutting fluid as a lubricant and coolant, a stream of cutting fluid is used as the medium for conducting the ultrasound aimed at the part. A squirter assembly houses the transducer and shapes the stream of fluid to the tube. In the present applications, the squirter/transducer assembly has been mounted in the tool turret in place of a cutting tool. Figure 1 shows this arrangement.

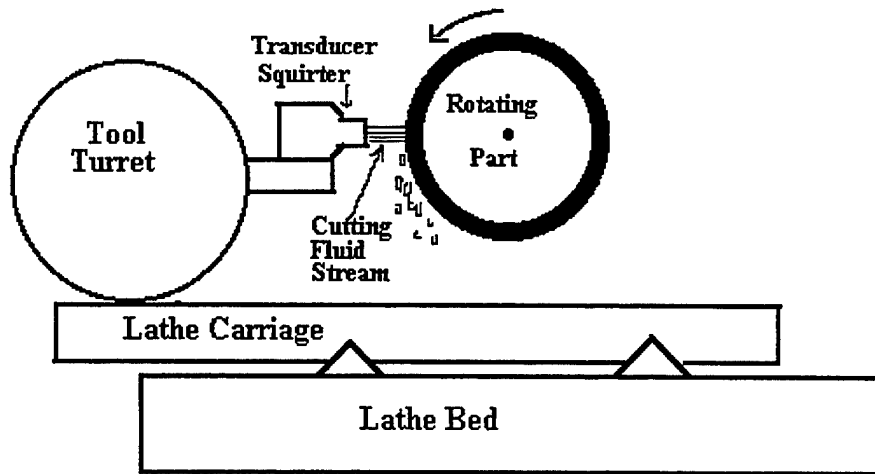

Figure 1. Transducer/squirter positioned on lathe relative to part.

Ultrasonic spike pulse excitation of the transducer sends a short pulse of ultrasound along the fluid stream to the tube. A portion of the ultrasonic pulse reflects back to the transducer from the outside surface of the tube, and some is transmitted through to the inside surface from which it reflects back to the transducer. The same transducer is used for both excitation and reception of reflected echoes.

The wall thickness and outside surface location for all points on the tube are determined by measuring the ultrasonic echo delay times and using calibrated speeds of sound in the cutting fluid and part material to calculate distance and thickness. Figure 2 shows the relevant dimensions and locations of the transducer relative to the part to be gauged.

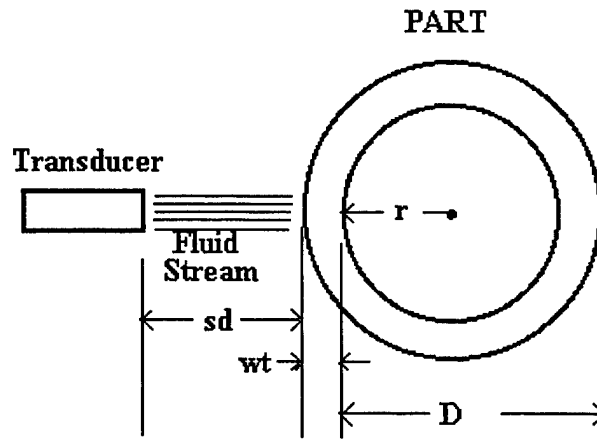

Figure 2. Part-transducer arrangement with relevant dimensions.

Figure 3 depicts the ultrasonic echo signals seen on an oscilloscope screen, along with the relevant time intervals.

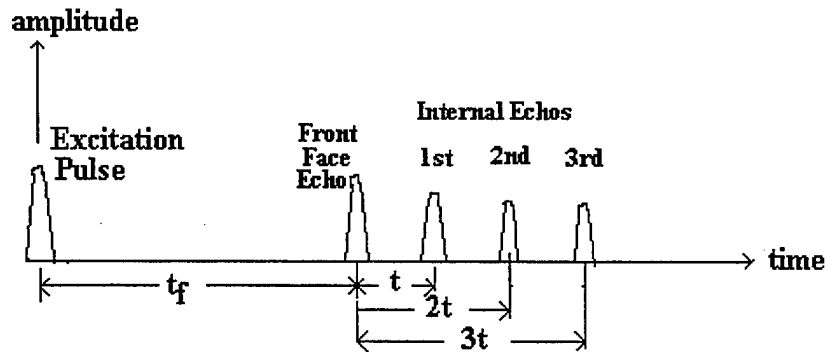

Figure 3. Times between echoes from part surfaces shown in Figure 2.

The distance between the transducer and outside surface of the part is

$$sd = t_f \cdot v_f / 2 \quad (1)$$

where sd and t_f are shown in Figures 2 and 3, respectively, and v_f is the speed of sound in the fluid couplant. A factor of 2 arises because the sound pulse travels to and back from the part in the process of generating Figure 3.

The wall thickness of the part is

$$wt = t \cdot v / 2 \quad (2)$$

where v is the sound velocity in the part. The wall thickness size can also be obtained by using the time delays between the front face and second or third internal echoes, i.e.,

$$wt = 2t \cdot v / 4 \text{ or } wt = 3t \cdot v / 6 \quad (3)$$

where the time interval $2t$ or $3t$ would be measured instead of t .

If the location of the transducer with respect to the lathe centerline is known, then the part runout and diameter can be obtained from a measurement of t_f . If the part is perfectly round, then the runout as a function of angle is

$$ro(\theta) = (t_f(\text{ave}) - t_f(\theta)) \cdot v_f / 2 \quad (4)$$

where $t_f(\text{ave})$ is the average value of t_f over a complete revolution. (This presumes that all of the runout is caused by the part not being perfectly centered on the lathe centerline.)

The procedure for measurement of the part radius is as follows. The lathe is set up so that the x position of the lathe cross slide is calibrated with the transducer/squirter in a known position. This is typically done by bringing the nozzle of the squirter in contact with a part having a precisely known diameter in the chuck. The lathe CNC controller is then zero set so that the x-axis readout gives the part diameter just as if the nozzle were a cutting tool. The lathe CNC controller is used to position the nozzle first at 0.125 in. (3.175 mm) away and t_{f1} is measured. The nozzle is next positioned at 0.375 in. (9.525 mm) away and t_{f2} is measured. The calibrated velocity of sound in the coupling fluid is then

$$v_f = 0.250/((t_{f2} - t_{f1})/2) \quad (5)$$

The nozzle is subsequently repositioned at a standoff distance of 0.250 in. (6.35 mm), which is the operational distance for gauging operations. The part is spun for a revolution while t_f readings as a function of angle are obtained. (Typically 2000 values of t_f are obtained.) The average of these values is then $t_f(\text{ave})$, which becomes a reference value representative of the location of the transducer when the nozzle is located 0.250 in. (6.35 mm) away from a part surface. This information can be interpreted by noting that if a value of $t_f(\text{ave})$ is observed, then the part radius, r_p , is equal to $(x/2) - 0.250$, where x is the value obtained from the lathe CNC controller indicating the diameter of a part. (The lathe CNC assumes that the part is being cut by a tool, now the squirter nozzle, with the x position being appropriately calibrated.) The radius as a function of angle is then obtained from the equation

$$r(\theta) = \frac{x}{2} + \left(t(\text{ave}) - t_f(\theta) \right) \cdot \frac{v_f}{2} - 0.250 \quad (6)$$

It is noted that $\left(t(\text{ave}) - t_f(\theta) \right) \cdot \frac{v_f}{2}$ is the runout, $r(\theta)$, for the part.

The 0.250 accounts for the fact that the lathe is set up to have the nozzle precisely 0.250 in. (6.35 mm) from the part while data are acquired. Once the lathe x-axis is calibrated for the transducer/squirter mounted as if it were a tool, equation (6) remains valid with the accuracy of the value of x representative of the lathe and its CNC controller.

By programming the lathe CNC to move the transducer/squirter along the length of the part as if it were a tool with a 0.250 in. (6.35 mm) standoff and acquiring $t(\theta)$ and $t_f(\theta)$ data with the part spinning, a detailed map of the wall thickness and runout can be provided as a function of angle and position along the length of the part. Once wall thickness and runout are known, the other parameters, including OD radius, ID radius, and concentricity, can be computed for all locations where the former have been measured. The position along the length of the part is typically called the z direction (along the bed) on a lathe. The lathe z and x position data are typically supplied to the ultrasonic gauging system via an RS232 link from the lathe CNC controller. This same kind of information can also be supplied in this fashion during the calibration operations described above. To date, we have only used one-way communications between the CNC and the ultrasonic gauging system computer. The CNC controllers used have not been able to accept commands from the ultrasonic system computer. If this were possible,

completely automated operation from calibration to data collection would be possible. With one-way communication, only completely automated data acquisition has been fully implemented.

Ultrasonic Measurement Issues

The connection between the ultrasonic echo time-delay data and part dimensions appears to be straightforward. Early attempts to use commercially available ultrasonic gauging instrumentation failed to yield sufficiently accurate results. When this instrumentation was used, uncertainties of several mils (0.001 in. (25.4 μm)) were common in spite of the fact that the instrumentation was capable of an order of magnitude better accuracy. Much of the loss of accuracy was traced to amplitude variations of the ultrasonic echoes. Since the video-detected signals have rise times on the order of 0.1 μs , typical variations of up to 10 dB easily resulted in time-interval uncertainties of 0.01 μs . This error is on the order of 0.001 in. (25.4 μm) in steel.

Errors caused by amplitude variations result from the use of voltage comparator circuits that trigger start and stop signals to a time-interval counter. The automatic gain control circuits typically used to maintain a fixed echo height (and thereby eliminate this problem) will not work in the lathe environment, since all measurements are single-shot opportunities when the part is spinning. Because each echo is individually affected by random signal fluctuations, it is not possible for the auto gain circuitry to adjust, in advance, the gain for an upcoming echo. Also, the amplitude of an echo that previously occurred and was used for a measurement cannot be corrected.

An additional issue arises from the requirement to operate in the face of possible substantial runout. This situation is best handled using a tracking trigger mode of operation where the ultrasonic instrumentation is synchronized with the reflected echo from the outside of the part. The synchronization permits an accurate setting of all subsequent echo gates with delays set from the front face echo instead of the excitation pulse. However, it is also necessary to use the front face echo to measure t_f . Commercial instrumentation is typically unable to both use a tracking trigger mode and make time-interval measurements from the same echo.

The setting of gates for all of the expected internal reflections used to measure wall thickness is done by selecting gate widths and time delays consistent with the range of wall thicknesses to be encountered and the echo number to be used. This setting is accomplished in the present system by data sent from the lathe CNC or a software setup program that dynamically sets the gate timing according to the z location of the tool holder on the lathe bed. Gate delay and width settings for the back face echo used for wall thickness measurement are necessary in order to make certain that the echo number used for the measurement is the one intended. If the gate is set inappropriately, multiple echoes could be in a gate or a different echo than desired could be in a gate.

Another difficulty encountered was the unexpected absence of one or both echoes due to reflecting surface imperfections or even holes through the thickness of the part. The absence of echoes leads to missing time-interval data, which in turn results in data arrays that are no longer aligned with the angular position in the part. (The ultrasonic excitation pulses are synchronized to part angular location by use of an encoder attached to the main shaft of the lathe to trigger the ultrasonic pulse firing. A 2000-line per revolution encoder is used.)

ULTRASONIC INSTRUMENTATION

An earlier version of the ultrasonic instrumentation is described in Reference 1. Figure 4 shows the basic schematic diagram for the current system.

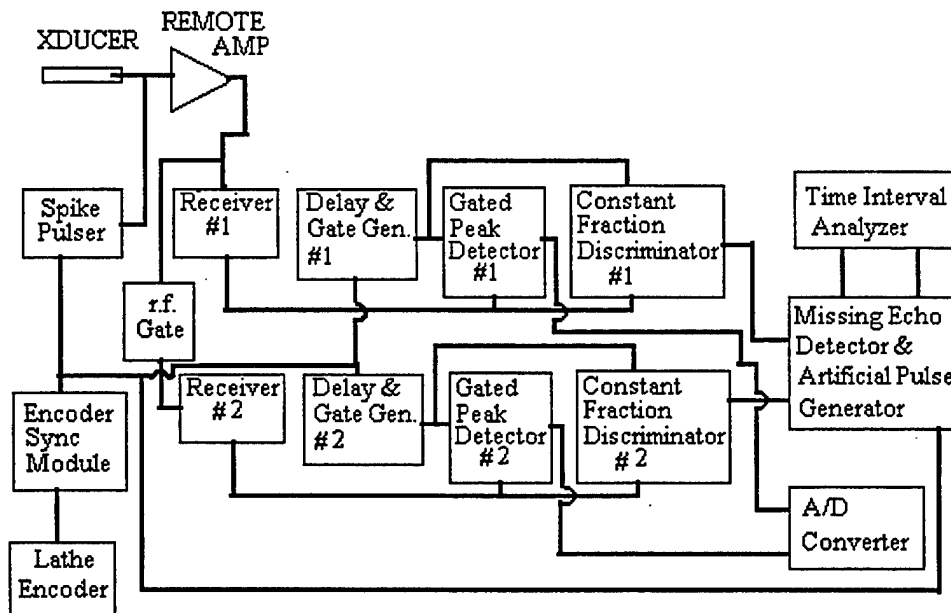

Figure 4. Basic gauging system schematic diagram.

The ultrasonic instrumentation shown in Figure 4 includes five plug-in cards that interface to an industrial PC through the ISA computer bus. The spike pulser and receiver #1 are contained in a Matec Instruments SR9000 pulser/receiver plug-in card. A Matec Instruments PD2000 dual-channel gated peak detector includes the delay and gate generators #1 and #2, as well as gated peak detectors #1 and #2. Receiver #2 is a custom card with a computer-controlled gain range of 80 dB. The A/D converter card is a 16-channel, 200 kHz, National Instruments AT-MIO 16F-5 plug-in card. The time-interval analyzer card is a Guide Technology GT654 plug-in card. The encoder synchronizer card is a custom card, which supplies either divided down encoder pulses or a free-running 1 kHz pulser to synchronize the entire system. Housed in a separate chassis and requiring no computer interface are the two constant fraction discriminator circuits, r.f. gate, and missing echo detector and artificial pulse generator circuits.

The lathe encoder is typically a 2000-line encoder and is attached to the lathe spindle. In the data collection mode, the encoder pulses are used to fire the ultrasonic pulser unit so that all data are completely synchronized with angular position on the part chucked in the lathe. A remote amplifier mounted directly on the transducer/squirter assembly on the lathe amplifies echoes returning from the transducer. This arrangement is important for two reasons. The shop environment is typically electrically noisy so that remote amplification boosts the signals well above the pick-up noise in the 30 to 50-foot cable from the transducer to the equipment rack. In addition, the amplifier and its input protection circuitry can be arranged to provide an appropriate 50-ohm cable termination for the spike pulser, while at the same time providing a high impedance load to the transducer when it is in the receiver mode of operation. This impedance matching provides a very substantial improvement in pulse fidelity so that very wideband transducer properties are not degraded and minimal transducer ringing contributes to very narrow video-detected ultrasonic echoes. The high fidelity, narrow time width echoes that result contribute substantially to the time-interval accuracy achieved.

The PD2000 gated peak detector card was modified to enable the tracking trigger circuitry to work on the echo reflected from the outside surface of the part (front face echo) and simultaneously allow that same echo to be used for making timing measurements for OD radius and wall thickness determination. The front face echo used for the tracking trigger, which becomes time zero for all gate delay and width functions in the system, is internally delayed by 600 ns so that it can be fully within a gate set to look at that signal amplitude. The units, called constant fraction discriminators (CFD), provide an output reference pulse that is referenced to the time of the peak location of the ultrasonic echoes. The reference pulse has a very fast rise time and is about 50 ns in duration. The CFDs provide very good immunity to variations in echo amplitude-caused errors in the time location of the echo. The CFDs are gate-enabled so that only echoes within a selected time location can cause an output pulse. CFD #1 is set to look at the front face echo, while CFD #2 is set to look at the echo reflected from the inside surface of the part.

Receiver #1 is automatically gain-controlled via computer instructions. Before automated data collection begins, the echo amplitude is set about 25 percent below the maximum signal for which amplifier saturation begins. (The CFDs only work well for non-saturated, high fidelity signals the shape of which do not change substantially with attenuation.) The r.f. gate passes the selected inside surface echo to receiver #2, which is also auto-gained to set an appropriate echo amplitude for it. The use of this gate is important because it blocks passage of the front face echo signal to the second receiver that would be highly overdriven when its gain is set high enough for the inside surface echoes. These echoes are typically from 15 to 40 dB smaller in amplitude. The amplifier recovery time so avoided is particularly important when gauging thin-walled parts.

The missing echo detector circuit senses a missing timing pulse (within an expected time interval) for either the front or inside surface echoes. This could happen for cases of localized surface damage or for holes drilled through the part wall. If either one or both echoes are missing, the circuit outputs replacement pulses with an out-of-range time interval that is then trapped in the software. This feature allows the time-interval data to be stored in data arrays so

that each row of the array contains data for each encoder pulse location in one revolution of the part. By putting artificial data in the array location where echoes are missing, the column location in each row continues to be exactly slaved with angle location on the part. Successive rows of data are for successive turns of the part. Then if the lathe carriage is moving with known speed-per-revolution of the part, the successive rows of data are slaved to known locations along the length of the part. It is noted that the system described in Reference 1 only replaced missing inside surface echoes. Subsequent experience showed that it was possible to have situations where front face echoes were absent, but not back face echoes.

The time-interval analyzer is used to make the timing measurements between the various ultrasonic echoes. It is capable of making up to 2×10^6 time-interval measurements per second and storing them in on-board memory until transferred to computer memory. The GT654 time-interval analyzer is capable of 75 ps resolution on a single-shot, time-interval measurement. The accuracy and flexibility of the GT654 is key to the high accuracy achieved with the gauging system. It has significantly more capabilities than a time-interval counter such as the Hewlett Packard 5370B that was used in the gauging system described in Reference 1. The GT654 has two input channels. It time tags each pulse that arrives in each channel. It can provide arrays of these time-tagged pulses each with 75 ps of resolution. Time intervals are obtained by subtraction of the appropriate time-tag values. Successive pulses for the system sync pulse and front face echo (from CFD #1) are sent to channel 1 of the GT654. Pulses for the back face echo (from CFD #2) are sent to channel 2. The calculated time interval between the system sync pulse, which fires the pulser, and the front face echo yield the value t_f of Figure 2. The calculated time interval between the front face echo and the back face echo yields the value of t in Figure 2.

The encoder sync module is used to select the density of measurements per revolution of the encoder. It can divide the number of pulses per revolution from the encoder by 2, 4, or 8 to lower the number of measurements made per revolution. A 2000-line encoder is typically used, but units up to 4000 lines per revolution have been employed. The number of encoder pulses per second cannot be so great that ultrasonic excitation pulses are initiated before all of the returning echoes initiated by the previous excitation pulse are acquired. This can limit the lathe spindle speed when large numbers of samples are recorded for a single revolution of the part.

A 133 MHz Pentium-based industrial PC running under TransErra HT Basic controls the ultrasonic system shown in Figure 4. This Basic is essentially identical to Hewlett Packard HP Basic. It allowed us to port a great amount of code developed for the system described in Reference 1 directly into the system described herein. The computer controls all of the setup and operational parameters of the system. It collects time-interval data from the GT654 and processes it in real time. The computer also contains the AT-MIO 16F-5 analog-to-digital converter card, two channels of which record the amplitudes of the front and back face echoes as read from the analog outputs of the gated peak detectors on the PD2000 gated peak detector card. This card is used for this purpose rather than the A/D converters on the PD2000 so that the data can be accessed via DMA channels by the computer.

The computer's color monitor gives a real-time color image of wall thickness during data collection operations. The image on the monitor is color coded so that each color (16 colors are used) represents a range of wall thicknesses. Each horizontal line across the image corresponds to a single revolution of the lathe, and successive lines show the changes in wall thickness as the lathe carriage traverses along the length of the part. For every revolution of the lathe, the monitor also displays a continuously updated numerical value for the average wall thickness and runout, along with the standard deviations in each parameter. All other parameters, ID radius, OD radius, etc., are available after completion of a data-taking operation. These other data may be displayed either in a color image format or on a line-by-line basis in a graphical format with a resolution of 0.0001 in. (2.54 μm). The echo amplitude data may also be displayed as a color image and can be very useful for observing blemishes in the surface finish or for observing surface-finish patterns such as those due to tool vibration (chatter).

The ultrasonic system is calibrated along with the velocity of sound calibrations. The above discussion concerning measurement of part OD radius indicates how the fluid couplant velocity of sound is calibrated. The velocity of sound in the material (usually a metal) being gauged is calibrated by using a precisely machined cylinder of the metal with at least four different wall thicknesses. These thicknesses are calibrated with a coordinate measuring machine with an accuracy of 0.00001 in. (0.254 μm). By measuring with multiple wall thicknesses, two parameters are calibrated; they are material velocity of sound and time-delay differences inherent in the differences in the electronic paths the echoes take through the system. (Recall that the front face echo has a built-in delay of 600 ns to permit the desired tracking trigger operation.) The time-delay calibration also accounts for the fact that the front face and back face echoes are reflected differently in phase by 180 degrees because the front face echo reflects from a "hard" interface and the back echo from a "soft" interface. It has been found that this calibration is good for at least a factor of three increase in wall thickness outside of the original calibration thickness range. This is due to the inherent linearity of the system.

In addition to the calibration just described, a secondary calibration of the amplitude changes on the time-interval measurements is made. Here, the part remains stationary and the front face and back face echoes are individually attenuated in 0.5 dB steps from a level of receiver saturation to where the amplitude is too low to get a measurement. A time-interval value is obtained for each echo amplitude value. A look-up table of correction values is then created so that each time-interval value measured can be corrected by using the corresponding amplitude value simultaneously recorded. These corrections are typically from 0 to 0.0005 in. (13.0 μm) in equivalent thickness or runout values. If the constant fraction discriminators worked perfectly, these amplitude correction data would all be zero. Without the constant fraction discriminators, these corrections would be two orders of magnitude larger.

During data-taking operations, the computer accumulates the time-interval and amplitude data and computes the relevant thickness and runout information using the calibration data just described. The computer also checks to see if any amplitude seen on a given revolution is getting too close to saturation and adjusts the gain accordingly for the next revolution of the part. Depending on the lathe on which the data are being acquired, the computer may also be receiving data on squirter/transducer location from the lathe CNC controller via an RS 232 data link. These data are used to update delay and gate information to be consistent with expected nominal part dimensional information.

TRANSDUCER AND SQUIRTER CONSIDERATIONS

A squirter is used to generate a stream of fluid (typically cutting fluid) to conduct the ultrasonic beam to the part. Care is taken with the squirter design to minimize swirl in the fluid stream. Greater flow smoothness and stability in the stream results in less noise in the ultrasonic signals and better gauging results. For our situation, a stream diameter of about 3/16 in. (4.8 mm) gives an optimal compromise between signal strength and pulse broadening due to part curvature. It was found experimentally that the transducer must be operated with a standoff length that puts the part in the very far field of the transducer beam pattern. If this requirement is not satisfied, it is found that small changes in transducer standoff length on the order of several mils (0.001 in. (25.4 μm)) can cause thickness measurement errors of about 1 mil. When operated in the far field, this does not occur. For instance, we typically use a 10 MHz unfocused transducer with a 1/8 in. (3.18 mm) diameter element. This transducer has a nearfield length in water of 0.66 in. (16.8 mm). We use a standoff distance of about 2.5 in. (63.5 mm) to eliminate this effect. (This gives a round-trip delay time of about 90 μs .) If the transducer could be moved closer, a better signal-to-noise signal would be obtained, but at the expense of wall thickness accuracy. For very thick parts, over about 1.5 in. (38.1 mm), it is sometimes necessary to work with a lower frequency transducer. In this case, a 5 MHz unfocussed transducer with a 1/4 in. (6.35 mm) diameter element is used with a slight loss in wall thickness accuracy due to the resulting slower rise and fall times of the video-detected echoes.

We have the best success using Panametrics videoscanner series of transducers, which offer very wideband, highly damped, performance with a reasonable output energy. Since the fluid stream would droop considerably with a 2.5 in. (63.5 mm) standoff, the squirter nozzle is designed with a very long inside water path of about 2 in. (51 mm). In this way, the transducer element can be located back from the part by 2.5 in. (63.5 mm), while the distance of the squirter tip to the part surface is only 1/4 in. (6.35 mm). The nozzle has an entrance diameter of 1/2 in. (13 mm) and is tapered to leave the last 1/4 in. (6.35 mm) with an exit diameter of 3/16 in. (4.8 mm). The fluid exit flow rate affects signal noise especially if cavitation starts. However, at slow, but quiet flow rates, the fluid does not effectively couple the ultrasound to a part turning at high rpm. The flow rate is adjusted as a compromise in this regard. Good success has been achieved with little signal degradation at part speeds such that the surface feet per minute is kept under about 2000 surface feet/min. (600 m/min.). In other words, a 1-foot (31-cm) diameter part can be run at 200 to 250 rpm maximum. With a 1000-line shaft encoder synchronizing the ultrasonic system, these speeds result in 3000 to 3500 ultrasonic pulses per second.

During the setup and calibration operations, it is very important that the transducer/squitter be precisely aimed so that the central axis of the beam is aligned along a diameter through the part and the center of rotation of the lathe axis. This ensures that the beam front reflects with maximum amplitude from the curved inside and outside surfaces of a hollow workpiece. Because these surfaces are curved, only the very central portion of the acoustic beam across the fluid beam width truly reflects back to the transducer. Requiring that the beam is aimed along a diameter ensures that the wall thickness and OD radius measured are really what are expected. To ensure precise aim, the transducer/squitter assembly is mounted in such a way as to facilitate small adjustments in the vertical height and in the horizontal aim angle. The operator adjusts these mounting "screws" while viewing the computer monitor, which is displaying a continually updated bar graph aiming tool that measures the sum of the front face and inside echo amplitudes. When the signal amplitude is maximized, the beam is precisely aimed along a part diameter. The aiming accuracy required is typically a few tenths of a degree, and needs to be best for the smallest diameter parts.

FLUID COUPLANT

The normally used fluid couplant has been the cutting fluid used on the lathe. In order to keep a relatively clean stream of fluid for coupling the ultrasound to the part, the fluid is pumped from the lathe sump through a filter to remove typical cutting debris. The best results have been achieved by pumping the fluid into a five-gallon settling tank located about 8 feet (2.4 m) above the squitter. This settling tank provides a steady pressure head to ensure a smooth couplant flow through the squitter. It also allows bubbles to rise to the surface. It was found that micro-bubbles can cause very substantial attenuation of the ultrasonic signals. Some cutting fluids (which are water soluble cutting oils diluted by water) can entrap extremely small bubbles and completely eliminate the ultrasonic signals. One particular cutting oil must be kept below about 3 percent in order to maintain good signal quality. Others are less demanding in composition. On one machine a large amount of "tramp" lubricating oil was seen to be floating on the cutting fluid in the lathe sump. If the fluid level became low enough to allow this tramp oil to get into the pump used to provide cutting fluid to the settling tank, all ultrasonic signals would be lost.

GAUGING ACCURACY

Limitations Due to Ultrasonic System

For typical operations, the ultrasonic system is capable of making time-interval measurements with a standard deviation of 0.5 to 1.0 ns when a 10 MHz unfocused wideband transducer with a 0.125 in. (3.18 mm) element is used. In commercial steels that have been measured, the speed of sound is about 2.3×10^5 in./sec (6.0×10^5 cm/sec). Since the time-interval measurement is for round-trip of an echo, which passes through the part twice, the time-interval measurement accuracy translates into a thickness accuracy of 0.0001 in. (2.5 μ m) standard deviation. This number would be appropriate for thickness measurements made using the first echo reflected from the inside surface (back face echo). The use of the second or third reflected echo has the potential for reducing the measurement standard deviation by a factor of 2 or 3. This is only true, however, if the time-interval measurements can be made with the same

standard deviation. For a steel part with a thickness exceeding about 0.5 to 0.75 in. (13 to 19 mm), using the second echo reduces the reflected echo signal-to-noise ratio in such a way that the net result is that no gain in accuracy is achieved. Typically, for wall thicknesses between about 0.2 and 0.6 in. (5 to 15 mm), the best results are obtained using the second reflected internal echo. For wall thicknesses between about 0.08 (2 mm) and 0.2 in. (5 mm), the third echo yields better results, and often the fourth echo is used for thinner walls than this. For wall thicknesses below about 0.07 in. (1.8 mm), the echo widths (in time) start to make the echoes merge together and make measurements difficult. For wall thicknesses thinner than 0.08 in. (2 mm), a higher frequency transducer is required to achieve good results. Transducers up to 25 MHz have been successfully employed to measure wall thicknesses down to 0.05-in. (1.3-mm) thick. For further information, Blessing et al. (ref 2) describe various material properties and their effect on the sound velocity in metals, along with the potential effects on ultrasonic thickness measurements.

A number of measurements were made to study the accuracy achieved with the system described. In the steels studied, the accuracy achieved is typically 0.0002 in. (5.0 μm) \pm 0.01 percent. The 0.01 percent term is due to velocity of sound variations in a typical material. In 6061-T6 aluminum alloys, the accuracy achieved was only 0.0002 in. (5.0 μm) \pm 0.1 percent, which was attributed to larger variations in the local sound velocities in the material. This was particularly true for extruded aluminum tubes. The sound velocity is affected by variations in alloy composition, internal stresses, and grain size. Having calibration samples from the same batch of material is particularly important to achieve good results. As noted above, calibrations are carried out with a minimum of four thicknesses spanning the range of interest. Once a careful calibration is accomplished, a system timing parameter that yields a time-correction constant due only to electronic path differences in the ultrasonic electronics is established. After this parameter is established, a simple velocity of sound recalibration is possible by making a single measurement of wall thickness on a spot on the part where the wall thickness has been accurately measured by other means. If recalibrations are made using a single calibration spot on the part, a full system calibration every few months is all that is needed to achieve the stated wall thickness accuracy.

A series of measurements have been made whereby the part was measured with the apparatus described here and the results compared to coordinate measurement machine (CMM) data. The results of these comparisons confirm the above-stated accuracies. The results also show that part rotation rates up to about 2000 surface feet per minute do not affect the accuracy, as long as the squirter flow can be adjusted to maintain good signal-to-noise. Measurements on parts gauged during cutting operations also show no observable loss of accuracy due to the cutting operations.

Limitations Due to Transducer Mounting

The accuracy achieved for OD radius and runout measurements is almost entirely limited by the accuracy of establishing the position of the transducer with respect to the lathe axes. If it is mounted in the lathe tool holder, and the lathe and its CNC controller have been calibrated, the x-axis location of the tool holder should be known with the same established accuracy. The x-axis readings provided by the CNC controller are, in many cases, given to 0.0001-in. (2.5- μm)

resolution. It is, however, unlikely that this is the accuracy that is maintained in a typical shop where temperature fluctuations of 10°F over a 24-hour period are not uncommon. The ultrasonic system resolution for distance between the transducer and the part is better than 0.0001 in. (2.5 μm). This resolution is in principle easier to achieve than for wall thickness measurements, since the velocity of sound in the fluid couplant is about one-fourth that of metal parts being gauged. Hence, the same timing resolution translates into one-fourth the uncertainty in the length of material traversed by the sound pulses. This accuracy is good only if the cutting fluid temperature has not changed significantly since the last calibration of the cutting fluid velocity of sound.

For a water couplant, the sound velocity changes about 0.1 percent per degree Fahrenheit. Hence, thermal drifts have a potential for causing significant uncertainties in the OD measurements. Fortunately, on a lathe the thermal time constants will be long for a large volume of cutting fluid in contact with a large metal lathe structure. Our attempts to calibrate the velocity of sound in the cutting fluid as a function of temperature did not meet with complete success. The major problem encountered was hysteresis that was caused by heat capacities of the transducer mount and lathe parts. A thermister thermometer was placed in the fluid path in the transducer/squirter unit to minimize thermal lag between the thermometer and cutting fluid. However, the actual position of the transducer with respect to the lathe axes was thought to be affected by thermal lags larger than the times used to change the cutting fluid temperature during the calibration efforts. This is an area that needs further study.

RESULTS

All results obtained using this system were for tubes supported in a lathe as described above. In order to evaluate the accuracy of measurements obtained, we had a portion of a tube machined to produce steps half an inch in length, with measured step heights of 0.0980 to 0.1060 in. (2.489 to 2.692 mm). The thicknesses of the tube wall obtained for each location were within the accuracy of mechanical measurements in light of the criteria given earlier. The accuracies of the thickness or radii results depend on the velocity of sound in the steel being measured with sufficient accuracy. In addition, the sound velocity must be uniform over the whole specimen. Time is the variable, which can be measured with great accuracy. An accuracy of about one nanosecond is achieved for echo transit times of approximately 10 microseconds, which yields an uncertainty of one part in 10^4 . What follows is a depiction and discussion of some of the results that were obtained with steel tubes. It is noted that the thickness can be depicted with color or with three- (or two-) dimensional plots, or with both. For color (or gray scale) images, each color (level of gray) represents a range of values of the distance measured and displayed.

The first example is provided in Figure 5, which shows the depth and extent of gouging on a tube with smooth inside and outside surfaces.

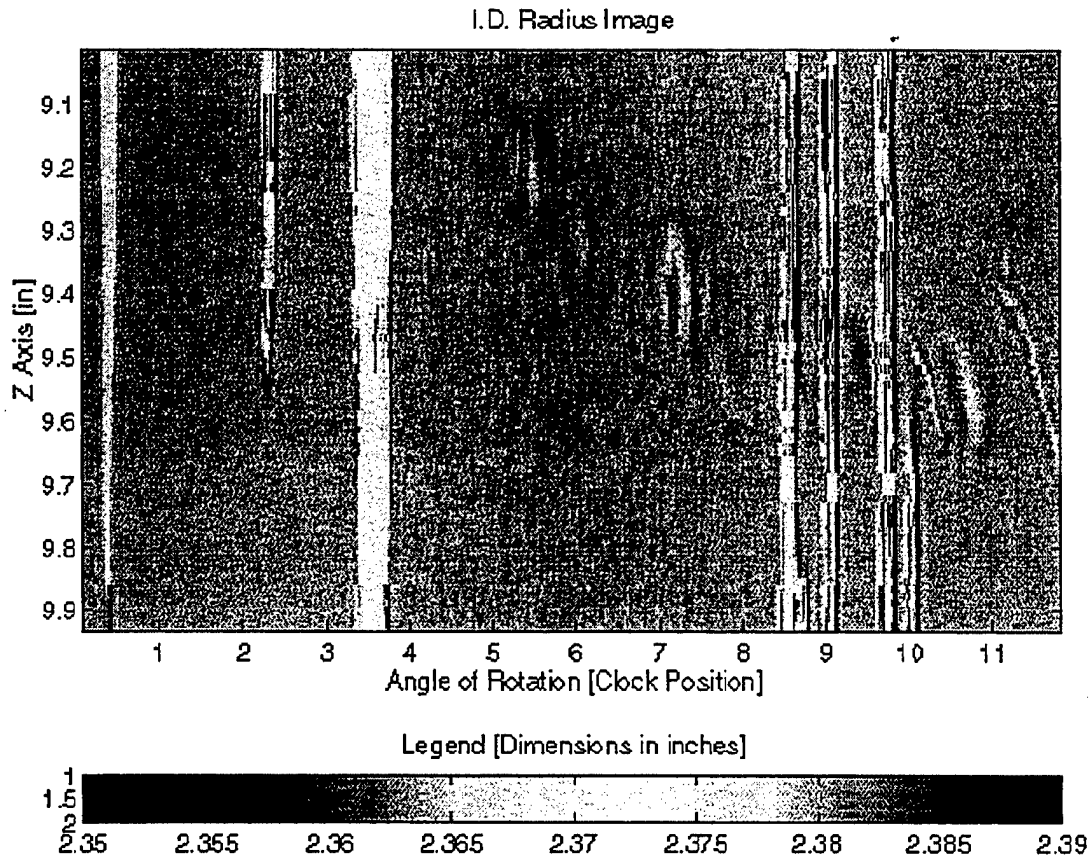

Figure 5. Shaded image of the ID radii, giving the topology of the bore of a chromium smooth bore tube, where some of the chromium is missing (here indicated by the lighter shaded streaks).

The shaded scale bar at the bottom of the image gives the ID radii of the tube. The horizontal scale is indicated by clock angle so that 0 and 12 o'clock are at the same angular position on the tube. The single-shot data shown in Figure 5 includes the radius of the hollow cylindrical tube with constant wall thickness. The tube has an OD of about seven inches. Although the tube had been chromium plated on the interior, the plating had suffered some damage due to use. The shaded picture shown here gives indications of localized wear damage. The image was obtained by making continuous scans, where 500 measurements were made per rotation. The distance between scans was fixed by the feed rate of the lathe (the distance that the transducer advanced along the bed for each rotation of the tube in the lathe).

Figure 6 shows a circular plot of a single horizontal scan line of the many that make up Figure 5. The data in this plot are offset by 2.36 in. (59.9 mm) in order to emphasize the changes in the ID radius. (Each scan line contains data for a single revolution of the tube.) In this figure, successive circles around the center represent 0.004-in. (0.1-mm) steps in the radius. From the figure, the extent and depth of each gouge can be clearly seen for the scan chosen.

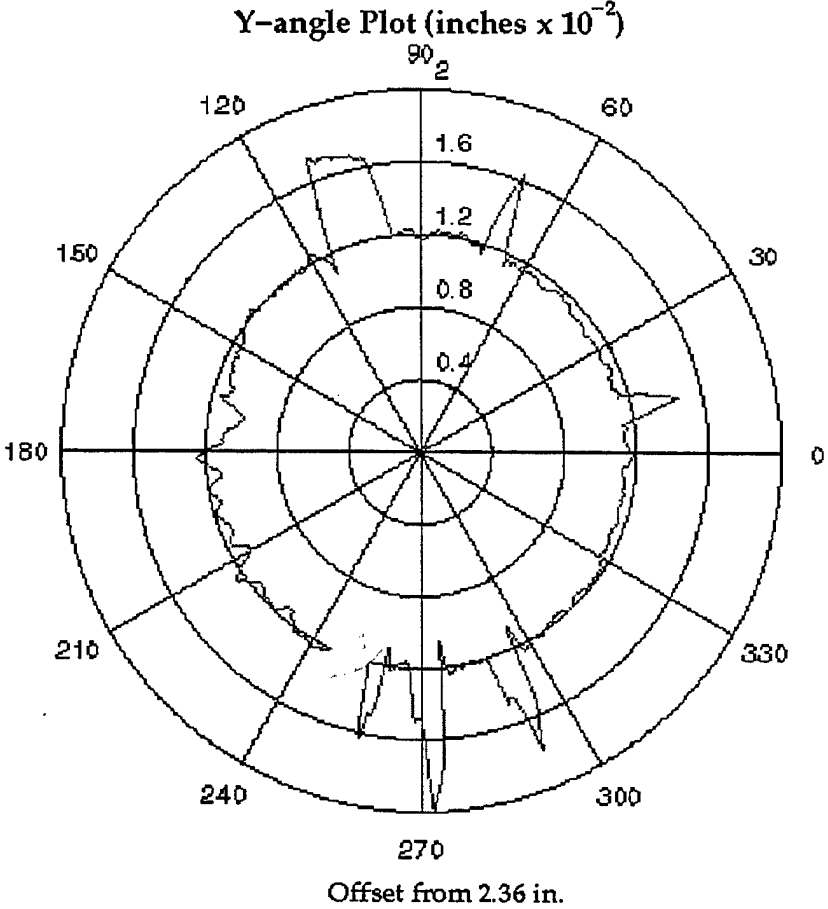

Figure 6. Data from one of the many scans comprising Figure 5. Tube ID radii (offset by 2.36 in.) are plotted with angular position. The amount and position of the gouging from the surface can be evaluated quantitatively.

Figure 7 is a three-dimensional depiction of a series of scans from a relatively uneroded tube. What is shown is the diameter of the ID, offset by a constant, for the tube, which had a series of lands and grooves.

Difference in Thickness between Lands and Grooves

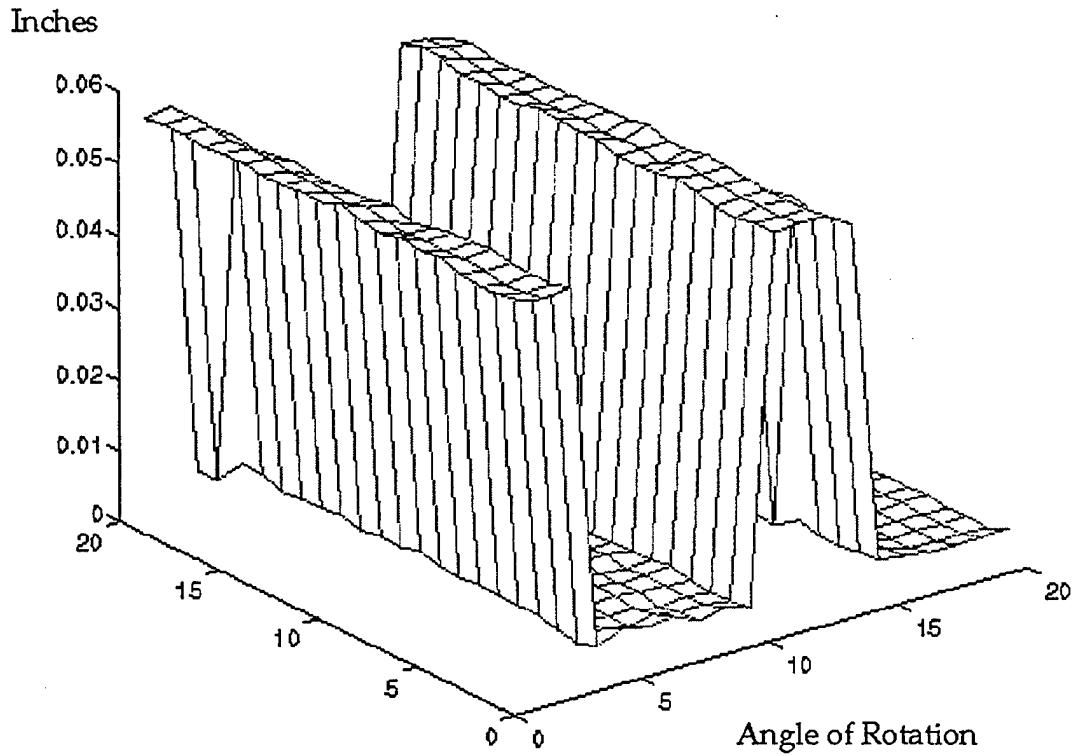

Figure 7. Lands and grooves from an uneroded tube.

Figure 8 shows data for lands and grooves for an eroded tube. These data were recorded at 500 measurements/revolution.

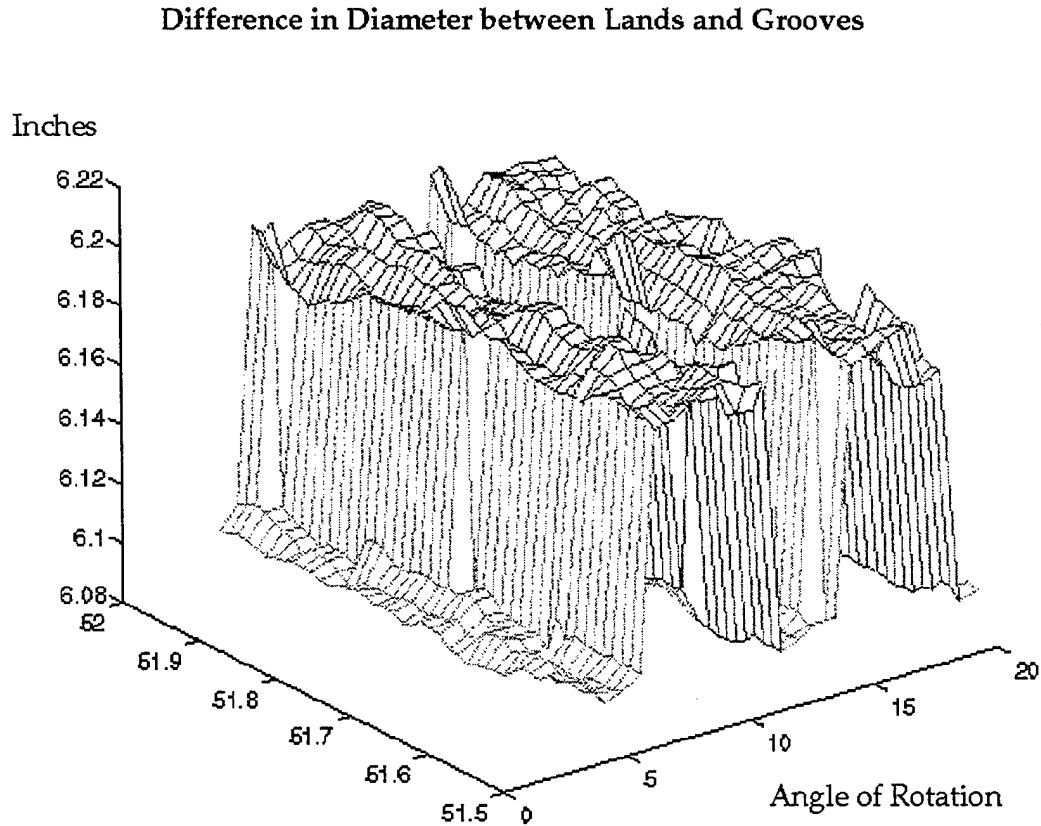

Figure 8. Lands and grooves from an eroded tube.

CONCLUSIONS

A computerized ultrasonic gauging technique for determining thickness or various dimensional parameters of rotating tubes in a lathe has been demonstrated. Up to 2000 measurements/rotation-of-wall thickness, OD radius, and inside and outside surface reflected echo amplitudes are routinely acquired. Examples have been given for applications to hollow cylindrical tubes with smooth inside and outside surfaces and to tubes with inside surfaces that have lands and grooves. For steel, the wall thickness measurement accuracy is 0.0002 in. (5.8 μm) ± 0.01 percent of the thickness. Small thickness changes due to corrosion, gouging, wear, or erosion can be known with unusually high accuracy from an automated measurement.

REFERENCES

1. Reed, R.W., "On-Machine Ultrasonic Gauging and Flaw Detection," *Review of Progress in Nondestructive Evaluation*, (D.O. Thompson and D. E. Chimenti, Eds.), Vol. 9, 1990, pp. 1949-1956.
2. Blessing, G.V., et al., "Precision Ultrasonic Thickness Measurements on Thin Steel Parts," *Materials Evaluation*, Vol. 49, 1991, pp. 982-986.

TECHNICAL REPORT INTERNAL DISTRIBUTION LIST

	<u>NO. OF COPIES</u>
CHIEF, DEVELOPMENT ENGINEERING DIVISION	
ATTN: AMSTA-AR-CCB-DA	1
-DB	1
-DC	1
-DD	1
-DE	1
CHIEF, ENGINEERING DIVISION	
ATTN: AMSTA-AR-CCB-E	1
-EA	1
-EB	1
-EC	1
CHIEF, TECHNOLOGY DIVISION	
ATTN: AMSTA-AR-CCB-T	2
-TA	1
-TB	1
-TC	1
TECHNICAL LIBRARY	
ATTN: AMSTA-AR-CCB-O	5
TECHNICAL PUBLICATIONS & EDITING SECTION	
ATTN: AMSTA-AR-CCB-O	3
OPERATIONS DIRECTORATE	
ATTN: SIOVV-ODP-P	1
DIRECTOR, PROCUREMENT & CONTRACTING DIRECTORATE	
ATTN: SIOVV-PP	1
DIRECTOR, PRODUCT ASSURANCE & TEST DIRECTORATE	
ATTN: SIOVV-QA	1

NOTE: PLEASE NOTIFY DIRECTOR, BENÉT LABORATORIES, ATTN: AMSTA-AR-CCB-O OF ADDRESS CHANGES.

TECHNICAL REPORT EXTERNAL DISTRIBUTION LIST

	<u>NO. OF COPIES</u>		<u>NO. OF COPIES</u>
DEFENSE TECHNICAL INFO CENTER ATTN: DTIC-OCA (ACQUISITIONS) 8725 JOHN J. KINGMAN ROAD STE 0944 FT. BELVOIR, VA 22060-6218	2	COMMANDER ROCK ISLAND ARSENAL ATTN: SIORI-SEM-L ROCK ISLAND, IL 61299-5001	1
COMMANDER U.S. ARMY ARDEC ATTN: AMSTA-AR-WEE, BLDG. 3022 AMSTA-AR-AET-O, BLDG. 183 AMSTA-AR-FSA, BLDG. 61 AMSTA-AR-FSX AMSTA-AR-FSA-M, BLDG. 61 SO AMSTA-AR-WEL-TL, BLDG. 59 PICATINNY ARSENAL, NJ 07806-5000	1 1 1 1 1 2	COMMANDER U.S. ARMY TANK-AUTMV R&D COMMAND ATTN: AMSTA-DDL (TECH LIBRARY) WARREN, MI 48397-5000 COMMANDER U.S. MILITARY ACADEMY ATTN: DEPT OF CIVIL & MECH ENGR WEST POINT, NY 10966-1792	1
DIRECTOR U.S. ARMY RESEARCH LABORATORY ATTN: AMSRL-DD-T, BLDG. 305 ABERDEEN PROVING GROUND, MD 21005-5066	1	U.S. ARMY AVIATION AND MISSILE COM REDSTONE SCIENTIFIC INFO CENTER ATTN: AMSAM-RD-OB-R (DOCUMENTS) REDSTONE ARSENAL, AL 35898-5000	2
DIRECTOR U.S. ARMY RESEARCH LABORATORY ATTN: AMSRL-WM-MB (DR. B. BURNS) ABERDEEN PROVING GROUND, MD 21005-5066	1	COMMANDER U.S. ARMY FOREIGN SCI & TECH CENTER ATTN: DRXST-SD 220 7TH STREET, N.E. CHARLOTTESVILLE, VA 22901	1
COMMANDER U.S. ARMY RESEARCH OFFICE ATTN: TECHNICAL LIBRARIAN P.O. BOX 12211 4300 S. MIAMI BOULEVARD RESEARCH TRIANGLE PARK, NC 27709-2211	1		

NOTE: PLEASE NOTIFY COMMANDER, ARMAMENT RESEARCH, DEVELOPMENT, AND ENGINEERING CENTER,
BENÉ LABORATORIES, CCAC, U.S. ARMY TANK-AUTOMOTIVE AND ARMAMENTS COMMAND,
AMSTA-AR-CCB-O, WATERVLIT, NY 12189-4050 OF ADDRESS CHANGES.
