

ARMY RESEARCH LABORATORY



Registered Frequency-Stepped Radar Data Collected on a Maneuvering Pickup Truck at K_a -Band

Geoffrey H. Goldman

ARL-TR-1936

May 1999

19990615 001

Approved for public release; distribution unlimited.

DTIC QUALITY INSPECTED 1

The findings in this report are not to be construed as an official Department of the Army position unless so designated by other authorized documents.

Citation of manufacturer's or trade names does not constitute an official endorsement or approval of the use thereof.

Destroy this report when it is no longer needed. Do not return it to the originator.

Abstract

Two-dimensional inverse synthetic aperture radar (ISAR) imagery can be generated with a stationary radar illuminating a moving target. Data were collected on a 1994 Chevy Cheyenne 1500 series pickup as it was slowly pulled through a stationary radar beam to help analyze noncooperative ISAR algorithms. The speed of the vehicle varied from constant velocity to constant acceleration and the turning angle of the wheels was constant. The radar was a frequency-agile, coherent, pulsed K_a -band instrumentation radar built by the U.S. Army Research Laboratory (ARL). The data were registered optically and with stationary and rotating reflectors.

Contents

Introduction	1
Measurement	2
Radar Characteristics	3
Registration	4
Target Motion	7
Results	9
Conclusions	11
Acknowledgments	12
References	12
Appendix. Visualization Software Code	13
Distribution	15
Report Documentation Page	17

Figures

1. Setup for noncooperative ISAR measurements	2
2. Registration of pickup truck	5
3. Mobile radar registration reflector	6
4. Optical image of target obtained from video camera tape	6
5. Uncalibrated bandwidth-averaged RCS of data file nciah	10
6. Uncalibrated HRR profiles of data file nciah	10

Tables

1. Radar characteristics at K_a -band	3
2. Approximate target motion parameters	7
3. Description of data runs	8

Introduction

Real-beam radars have been used for many years to detect and track moving targets, but they have had limited success with the identification of targets. Typically, the input to a target identification algorithm from a real-beam radar has been one-dimensional (1-D) high-range-resolution (HRR) profiles. Two-dimensional high-resolution imagery from a real-beam radar is more difficult to generate, but it has the potential to greatly improve automatic target recognition (ATR) algorithm performance.

Synthetic aperture radar (SAR) techniques have been extensively studied, and many SAR systems have been successfully implemented that generate high-resolution 2-D imagery. The synthetic aperture is typically generated by a side-looking radar within an airplane that is flying in a straight trajectory. The basic scenario that describes noncooperative inverse synthetic aperture radar (ISAR) data collection consists of a stationary radar that illuminates a moving target. The radar could be tracking the target or the radar could be pointed at a fixed location with a target driving through the radar beam. In either case, the processing techniques are very similar. A basic processing technique for SAR/ISAR is range-Doppler imaging [1,2]. This technique does not generate optimally focused imagery, but at high frequencies, focusing errors are small and it is computationally efficient. In general, a high ratio of crossrange to downrange motion is desirable.

ISAR images generated with a radar operating at millimeter-wave (MMW) frequencies have advantages and disadvantages over images generated with longer wavelengths. The image resolution in the crossrange direction is proportional to frequency, so higher resolution images can be generated with a higher frequency radar. At higher frequencies, a larger frequency bandwidth is usually available, so higher downrange resolution can also be achieved. The major disadvantages of operating at higher frequencies are increased cost and reduced power. Also, high-frequency radar returns are more sensitive to small changes in the aspect angle of the target.

Measurement

Radar data were collected for testing noncooperative ISAR algorithms at range 8 at Aberdeen Proving Ground, MD, on 24 September 1998. Figure 1 shows the setup of the radar, target, and registration reflectors. A John Deere tractor was used to slowly pull a 1994 Chevy Cheyenne 1500 series pickup truck on a paved road through the radar beam. (We used a tractor because it could maintain a slow speed easier than the pickup.) A 50-ft rope was attached between the tractor and the pickup truck. The radar illuminated a fixed volume and did not track the target.

Figure 1. Setup for noncooperative ISAR measurements.

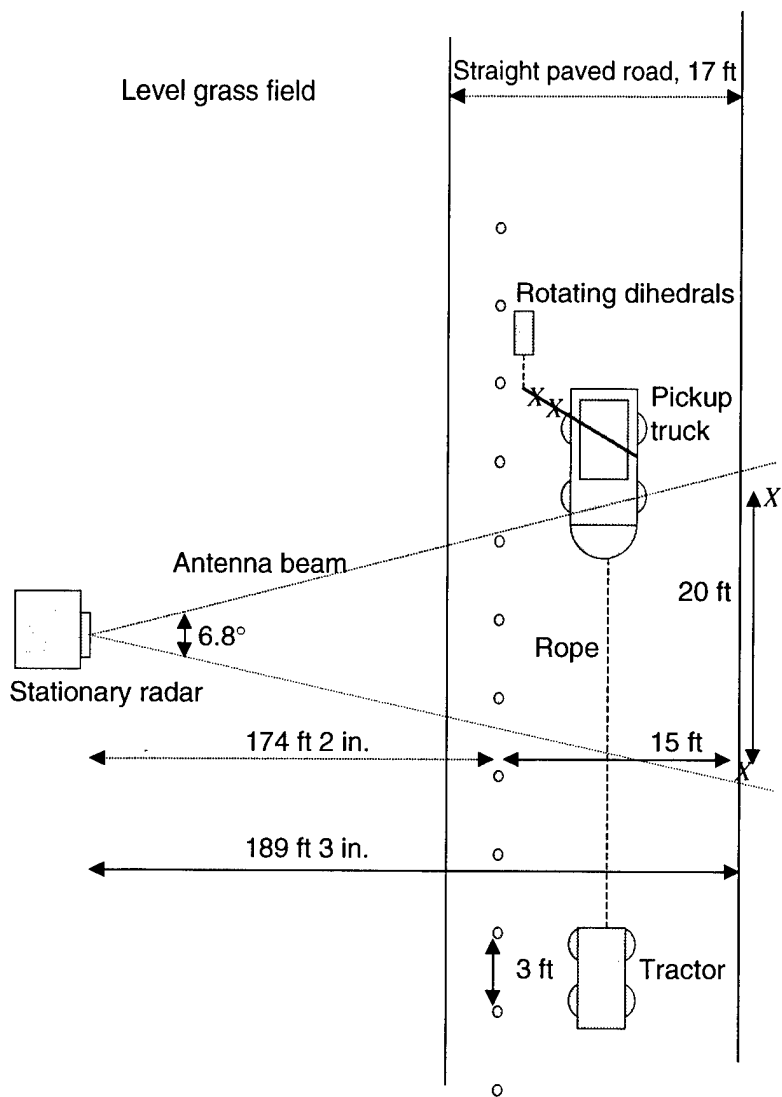

Note: X denotes trihedral reflector;
o denotes styrofoam cup.

Radar Characteristics

The U.S. Army Research Laboratory (ARL) has a coherent fully polarimetric radar system capable of operation at X-band, K_a -band, or W-band [3]. Table 1 lists the characteristics of the K_a -band radar system that was used to measure the test target.

The in-phase and quadrature (I&Q) outputs of the system are sampled with a 12-bit analog-to-digital (A/D) converter for each pulse. Four A/D converters sample the vertical and horizontal I&Q returns from vertically (V) and horizontally (H) transmitted pulses for 256 stepped frequencies. Data are averaged over pulse groups and stored as 256 I&Q pairs for both the vertical and horizontal receive channels.

For this measurement, data were collected synchronously, but not uniformly. Conceptually, two streams of data were collected at sample intervals of 50 ms. The streams were separated in time by 16.6 ms. The radar is fully polarimetric, but only transmit vertical, receive vertical (VV) polarization was recorded due to field test requirements. The data were calibrated using software developed by the Millimeter-Wave Branch at Aberdeen Proving Ground, MD [4].

Table 1. Radar characteristics at K_a -band.

Characteristic	Value
Maximum frequency	34.8 GHz
Minimum frequency	33.2 GHz
rf bandwidth	1.6 GHz
Frequency step	6.3 MHz
Peak transmitted power	+20 dBm
Pulsewidth	100 ns
Pulse repetition frequency (PRF)	1.0 MHz
Transmitted polarization	V or H
Received polarization	V and H
3-dB beamwidth (one way)	8.6°
System noise figure	9 dB (single sideband)
Polarization isolation	25 dB

Registration

The measurements were registered using an optical video camera with a zoom lens and several radar reflectors. The video camera was mounted on the radar. Styrofoam cups visible to the camera were placed at 3-ft intervals along the road. The cups were approximately 18 in. from the edge of the road that was closest to the radar. Trihedral reflectors were placed slightly beyond the road and 20 ft apart. The two-way 3-dB beamwidth of the radar at this range was approximately 21 ft. The radar cross section (RCS) of the trihedrals were 14.6 and 16.5 dBsm at 34 GHz; however, they were only visually aligned with the radar. The heights of the reflectors were slightly lower than the height of the hood of the pickup truck.

Radar reflectors and masking tape were used to register the location of the pickup truck. Their relative positions, described in units of feet and inches, are shown in figure 2. The pickup truck was marked with 4-ft vertical strips of tape at the center of each wheel. The tape was broken, so the wheels could turn freely. A reflector array mounted on a 2 × 4 in. board was placed across the bed of the truck. The array consisted of two trihedral reflectors mounted at the positions indicated in figure 2 and a mobile radar registration reflector (MRRR) attached with a string to the end of the 2 × 4 in. board. The RCS of the trihedral reflectors was approximately 1.3 dBsm at 34 GHz. The reflector array was positioned so that it could easily be cropped out of the image. Measurements of the target were made with and without the reflector array.

The MRRR is a skateboard with a small dihedral reflector mounted on each rear wheel. Figure 3 is a picture of the reflector. Radar absorbing material was glued to the skateboard to reduce returns from the support structure for the wheels. The RCS of the dihedrals was approximately -4 dBsm at 34 GHz. The radius of the wheels was approximately 0.979 in. The rotating dihedrals will produce a modulated radar return that can be fit to determine the position of the MRRR. The position of the MRRR can be used to help estimate the position of the pickup truck.

Figure 4 is a picture of the target with optical registration and radar reflectors taken from the video camera that was mounted on the radar. In the run selected, a speed bump was placed on the road. The speed bump can be seen directly below the intersection of the pickup truck cab and the bed. Time was also recorded, but it is cropped out of the image.

Figure 2. Registration of pickup truck.

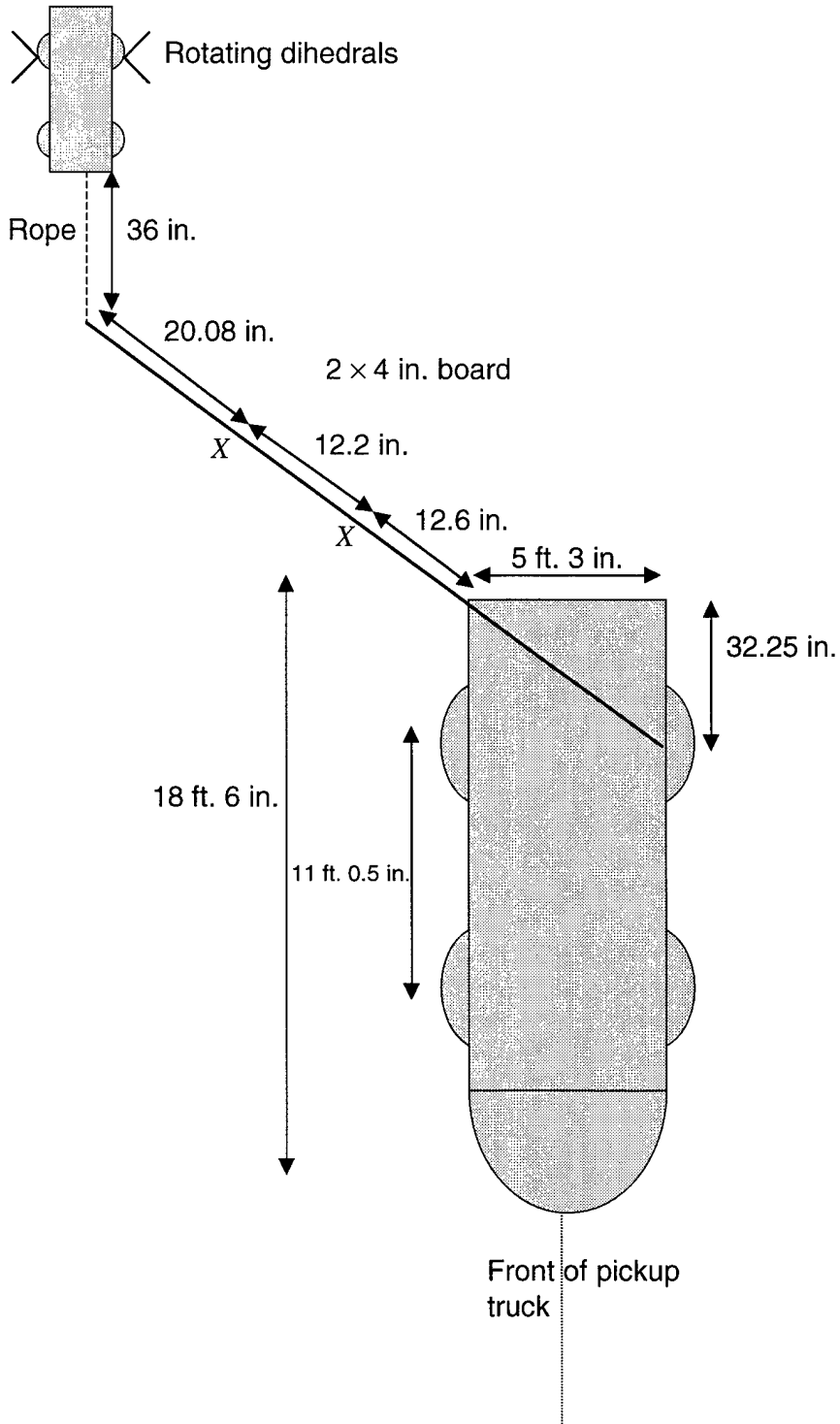

Notes: X denotes trihedral reflector.

Figure 3. Mobile radar registration reflector.

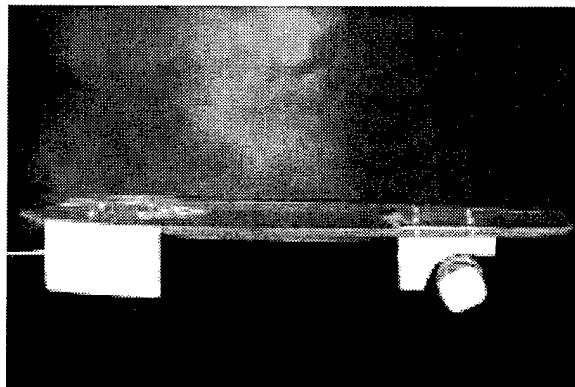
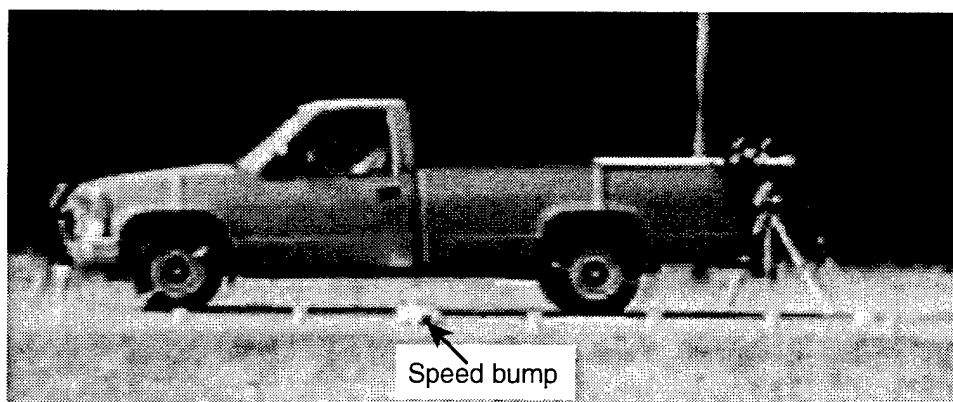

Figure 4. Optical image of target obtained from video camera tape.



Target Motion

Radar data were collected for various target trajectories. The speed of the pickup truck was controlled by the person driving the tractor. The goal of the tractor driver was to maintain a speed with either constant velocity or constant acceleration, depending on the selected scenario. The steering wheel of the pickup was controlled by a person. The goal of this person was to keep the angle of the front wheels constant while keeping the vehicle on the road. Turns were initiated when the front of the vehicle crossed the leading 3-dB beamwidth of the radar and stopped when the end of the vehicle crossed the trailing 3-dB beamwidth of the radar. Table 2 contains some approximations of the motion parameters of the target.

Two runs were made with the target going over a speed bump. The speed bump was used to introduce a controlled 3-D perturbation to the motion of the target. The speed bump was 8 in. long and 3-1/2 in. high. The motion of the target was dramatically changed by the bumps. It slowed down while attempting to go over the bump, and it sped up after it cleared the top of the bump. While most of the runs were made with the registration reflector array on the target, several runs were made without it. Table 3 describes the target motion, registration, and potential problems for each run. The data files were stored in ASCII format. The first column of the data file is the time in milliseconds. The second and third columns are I&Q values, which are associated with a specific radar frequency. There are 256 frequencies that were monotonically stepped and recorded. The registration field indicates whether the reflector array was secured to the pickup. The time that the video was started, the time that the tractor started pulling the pickup, and the time that the data file was recorded are shown in table 3.

Table 2.
Approximate target motion parameters.

Motion parameter	Approximate value
Velocity	1 ± 0.5 m/s
Acceleration	0.5 ± 0.5 m/s
Maximum angle of wheel	$15^\circ \pm 5^\circ$

Table 3. Description of data runs.

Filename	Description	Registration	Start time on video	Start time of tractor	Time stamp of data file
nciAf	Constant velocity	Yes	1:10	15:23	15:30
Removed trihedral from grass near the edge of the road closest to the radar. Moved trihedral on far edge of road 1 m farther downrange.					
nciAg	Constant velocity	Yes	1:00 (reset)	15:53	15:58
nciAh	Turning from far side to near side of road	Yes	8:48	16:00	16:06
nciAi	Turning from near side to far side of road	Yes	15:40	16:07	16:12
nciAj	Speed bump VHS tape broke during run	Yes	22:55	16:15	16:20
nciAk	Speed bump	Yes	29:50	16:22	16:26
ncial	Constant velocity	No	36:40	16:28	16:33
nciam	Constant acceleration, no turning	No	43:20	16:34	16:40
ncian	Turning from far side to near side of road with acceleration	No	50:10	16:42	16:47

Results

A total of nine frequency-stepped radar data files and video records were collected for various scenarios. Plots of the data were generated for file nciah. Figures 5 and 6 show plots of the bandwidth-average RCS and HRR profiles as a function of ramp number or, equivalently, time. Data of the target are plotted for ramps that were collected within the 3-dB beamwidth of the radar. Figures 5 and 6 show uncalibrated data that were not significantly different from the calibrated data. The code to generate these plots is included in the appendix.

Figure 6 shows that under certain circumstances, a mirror image of the target was formed in the HRR profiles with 10 to 15 dB of attenuation for both calibrated and uncalibrated data. This phenomenon was associated with large radar returns from the target and with a frequency response that was bell-shaped rather than flat. We are investigating this problem to determine whether it is a radar or a calibration problem.

Initial analysis of the HRR profiles indicated that the MRRR produced a modulated RCS signal that could be dynamically fit to estimate the motion of the target. The signal peak-to-trough ratio was approximately 10 dB, which is high enough to identify a half rotation of the wheel. Estimating the motion of the MRRR reflector was complicated by the lack of lateral stability of the skateboard. The MRRR had a tendency to oscillate from side to side, particularly during runs that involved turns. After the second run, the stability was improved by reducing the length of the string that attached the MRRR to the 2×4 in. board. If the target motion and measurement noise models are known, then Kalman filter techniques can be used to estimate the target position. If some of the model parameters are unknown, then techniques such as differentiated Kalman filter scoring can be applied. These techniques have not yet been applied to the data. Future tests should either use a better supporting structure, or a dihedral reflector should be mounted on the wheels of the vehicle.

Figure 5.
Uncalibrated
bandwidth-averaged
RCS of data file
nciah.

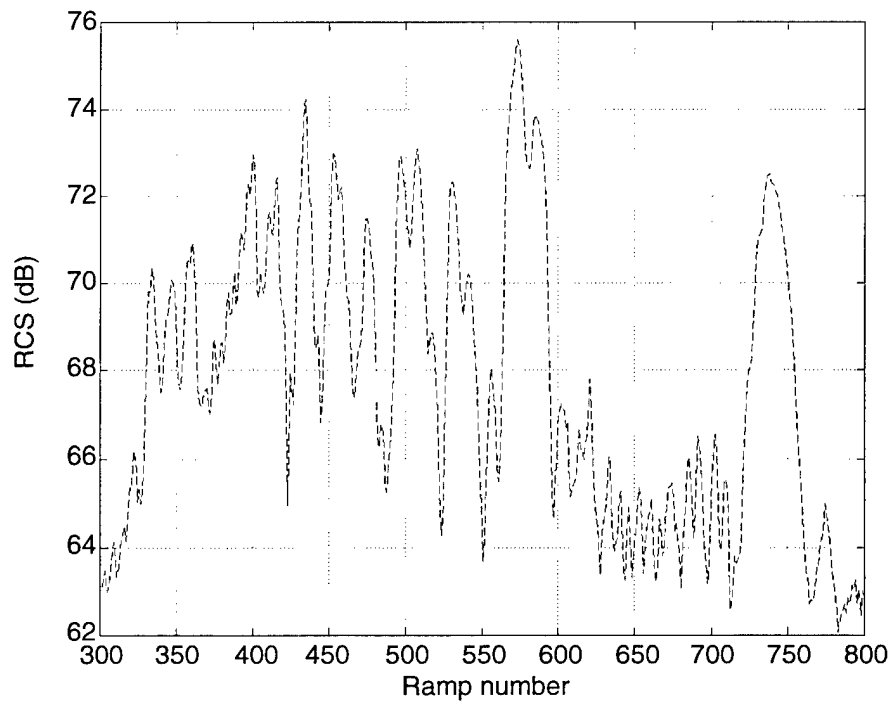
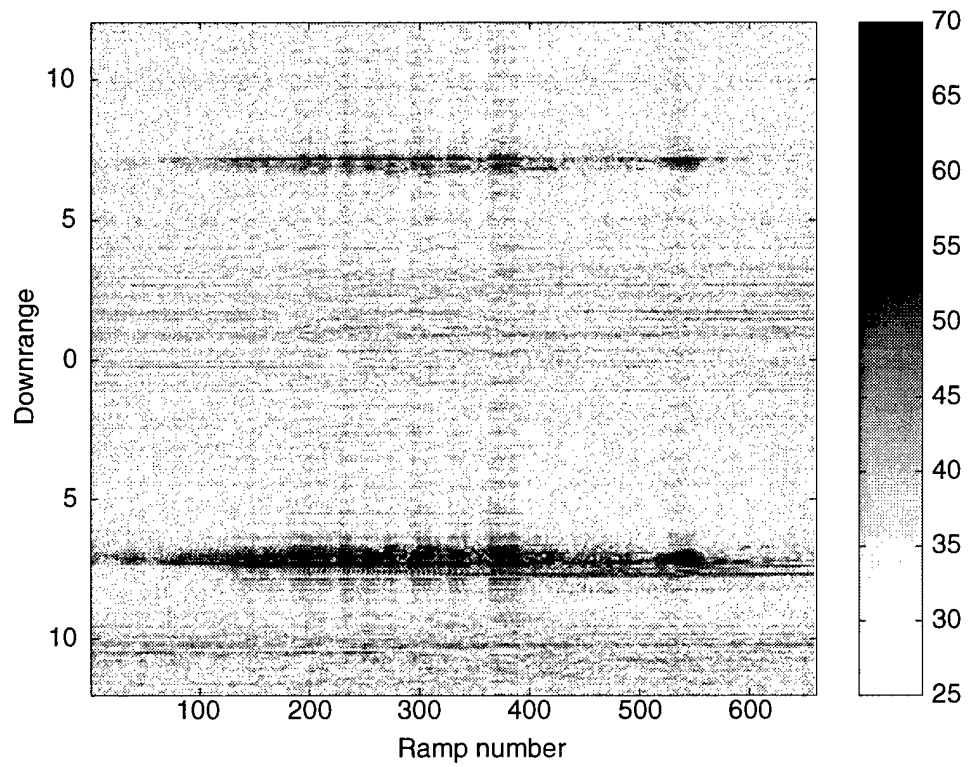

Figure 6.
Uncalibrated HRR
profiles of data file
nciah.



Conclusions

Frequency-stepped radar data were collected on a slowly moving 1994 Chevy Cheyenne 1500 series pickup truck at K_a -band for VV polarization. Extensive radar and optical registration measurements were made. An initial analysis of the data was performed. The stationary and mobile registration reflectors were visible and sharply imaged. HRR profiles of the target looked good for most of the runs. On a few runs, false or ghost images of the target were seen in HRR profiles. This problem is being investigated.

A new MRRR reflector was designed and built to help register the radar data. The reflector modulated a radar signal that could be analyzed to estimate the target motion. However, there were lateral oscillations in the motion of the reflector that complicated the estimations of the motion of the target. Future tests should develop techniques to eliminate the problem.

Currently, ARL and the Naval Research Laboratory (NRL) are developing algorithms that can be tested using these data [5]. Testing these and other algorithms developed by industry and academia on real data should provide further insight into the development of improved ATR algorithms for weapon systems that use a real-beam radar.

Acknowledgments

I would like to thank Suzanne R. Stratton, Robert L. Bender, and Tim Burcham of ARL, who built and maintain the instrumentation radar system and who collected the data. I also would like to thank Art Harrison and Bill Potter of ARL, who helped me construct the MRRR.

References

1. J. L. Walker, "Range Doppler Imaging of Rotating Objects," *IEEE Trans. Aerosp. & Electron. Syst.* **AES-16**, 1 (1980).
2. D. A. Ausherman, A. Kozma, J. L. Walker, H. M. Jones, and E. C. Poggio, "Developments in Radar Imaging," *IEEE Trans. Aerosp. & Electron. Syst.* **AES-20**, 4 (July 1984).
3. S. R. Stratton, H. B. Wallace, R. L. Bender, and A.E.M. Broden, *A Comparison of Radar Cross-Section Measurements of 11 T72M1 Tanks at 35 GHz*, U.S. Army Research Laboratory, ARL-TR-1421 (July 1997).
4. R. L. Bender, *Use of a Remotely Controlled Dihedral for Calibrating a Polarimetric Radar*, U.S. Army Research Laboratory, ARL-MR-318 (June 1996).
5. G. H. Goldman and H. Dropkin, *High-Frequency Autofocus Algorithm for Noncooperative ISAR*, U.S. Army Research Laboratory, ARL-TR-1890 (May 1999).

Appendix. Visualization Software Code

```
function nci_data_report(fname,cal_flag)
% nci_data_report: quick visualization script for non-cooperative ISAR data
% collected on Sept 24, 1998, at Aberdeen Proving Ground.
% written by Jeff Goldman

if (nargin ~= 2)
    error('input: filename in single quotes, calflag 0=uncalibrated data, 1=calibrated')
end

eval(['load ' fname])
data=eval([fname]);
[num_ele,three]=size(data);

num_freq=256;
num_ramps=fix(num_ele/num_freq);

iq=zeros(num_freq,num_ramps);
times=zeros(1,num_ramps);

for ir=1:num_ramps
    times(1,ir)=data((ir-1)*num_freq +1,1);
    iq(:,ir)=data((ir-1)*num_freq +1:ir*num_freq,2) -i*data((ir-1)*num_freq +1:ir*num_freq,3);
end

if (1) % high range resolution profiles

    hrr = fft(iq,num_freq)/(num_freq); % hrr profiles, but use same data structure

    for iaz=1:num_ramps
        hrr(:,iaz) = fftshift(hrr(:,iaz));
    end

    hrr_power=10*log10(hrr.*conj(hrr));

    bw= 1.6e9; % radar bandwidth
    c=3e8; % speed of light

    figure
    dr=((1:num_freq) - num_freq/2)*c/(2*bw);
```

```

cr=1:num_ramps;
imagesc(hrr_power,[25,70])
colorbar('vert')

figure
dr_offset=0;
num_dr=256;
cr_offset=200;
num_cr=660;

if (cal_flag==0)
    dr=(-num_dr-dr_offset:-dr_offset) + num_freq/2)*c/(2*bw);
    cr=1:num_cr;
    cs=[25,70]; % color scale in dB
    imagesc(cr,dr,hrr_power(1+dr_offset:dr_offset+num_dr,1+cr_offset:cr_offset + num_cr),cs)
    colorbar('vert')
else
    imagesc(cr,dr,hrr_power,[-25,-5])
    colorbar('vert')
end
ylabel('down range')
xlabel('ramp number')
title(fname)
end

```

Distribution

Admnstr
Defns Techl Info Ctr
Attn DTIC-OCP
8725 John J Kingman Rd Ste 0944
FT Belvoir VA 22060-6218

OSD
Attn OUSD(A&T)/ODDR&E(R) R J Trew
Washington DC 20301-7100

AMCOM MRDEC
Attn AMSMI-RD W C McCorkle
Redstone Arsenal AL 35898-5240

CECOM
Attn PM GPS COL S Young
FT Monmouth NJ 07703

Dir for MANPRINT
Ofc of the Deputy Chief of Staff for Prsnl
Attn J Hiller
The Pentagon Rm 2C733
Washington DC 20301-0300

US Army Armament Rsrch Dev & Engrg Ctr
Attn AMSTA-AR-TD M Fisette
Bldg 1
Picatinny Arsenal NJ 07806-5000

US Army Edgewood RDEC
Attn SCBRD-TD G Resnick
Aberdeen Proving Ground MD 21010-5423

US Army Info Sys Engrg Cmnd
Attn ASQB-OTD F Jenia
FT Huachuca AZ 85613-5300

US Army Natick RDEC Acting Techl Dir
Attn SSCNC-T P Brandler
Natick MA 01760-5002

Director
US Army Rsrch Ofc
4300 S Miami Blvd
Research Triangle Park NC 27709

US Army Simulation, Train, & Instrmntn
Cmnd
Attn J Stahl
12350 Research Parkway
Orlando FL 32826-3726

US Army Tank-Automtv Cmnd Rsrch, Dev, &
Engrg Ctr
Attn AMSTA-TA J Chapin
Warren MI 48397-5000

US Army Train & Doctrine Cmnd
Battle Lab Integration & Techl Dirctr
Attn ATCD-B J A Klevecz
FT Monroe VA 23651-5850

US Military Academy
Mathematical Sci Ctr of Excellence
Attn MDN-A MAJ M D Phillips
Dept of Mathematical Sci Thayer Hall
West Point NY 10996-1786

Nav Surface Warfare Ctr
Attn Code B07 J Pennella
17320 Dahlgren Rd Bldg 1470 Rm 1101
Dahlgren VA 22448-5100

DARPA
Attn B Kaspar
3701 N Fairfax Dr
Arlington VA 22203-1714

Hicks & Associates, Inc
Attn G Singley III
1710 Goodrich Dr Ste 1300
McLean VA 22102

Palisades Inst for Rsrch Svc Inc
Attn E Carr
1745 Jefferson Davis Hwy Ste 500
Arlington VA 22202-3402

US Army Rsrch Lab
Attn AMSRL-SE-RM R Bender
Attn AMSRL-SE-RM T Burcham
Attn AMSRL-SE-RM S Stratton
Aberdeen Proving Ground MD 21005

US Army Rsrch Lab
Attn AMSRL-CI-LL Techl Lib (3 copies)
Attn AMSRL-CS-AS Mail & Records Mgmt
Attn AMSRL-CS-EA-TP Techl Pub (3 copies)
Attn AMSRL-DD J Rocchio
Attn AMSRL-SE-EE W Potter
Attn AMSRL-SE-R B Wallace
Attn AMSRL-SE-RM E Addler

Distribution (cont'd)

US Army Rsrch Lab (cont'd)
Attn AMSRL-SE-RM E Burke
Attn AMSRL-SE-RM G Goldman (10 copies)
Attn AMSRL-SE-RM H Dropkin
Attn AMSRL-SE-RM J Silvious
Attn AMSRL-SE-RM R Wellman

US Army Rsrch Lab (cont'd)
Attn AMSRL-SE-RM T Pizzillo
Attn AMSRL-SE-RU A Harrison
Attn AMSRL-SE-RU B Scheiner
Attn AMSRL-SE-SE T Kipp
Adelphi MD 20783-1197

REPORT DOCUMENTATION PAGE			<i>Form Approved</i> <i>OMB No. 0704-0188</i>	
Public reporting burden for this collection of information is estimated to average 1 hour per response, including the time for reviewing instructions, searching existing data sources, gathering and maintaining the data needed, and completing and reviewing the collection of information. Send comments regarding this burden estimate or any other aspect of this collection of information, including suggestions for reducing this burden, to Washington Headquarters Services, Directorate for Information Operations and Reports, 1215 Jefferson Davis Highway, Suite 1204, Arlington, VA 22202-4302, and to the Office of Management and Budget, Paperwork Reduction Project (0704-0188), Washington, DC 20503.				
1. AGENCY USE ONLY (Leave blank)		2. REPORT DATE May 1999	3. REPORT TYPE AND DATES COVERED Final, Jan 1998 to Dec 1998	
4. TITLE AND SUBTITLE Registered Frequency-Stepped Radar Data Collected on a Maneuvering Pickup Truck at K _s -Band			5. FUNDING NUMBERS DA PR: AH16 PE: 612120A	
6. AUTHOR(S) Geoffrey H. Goldman				
7. PERFORMING ORGANIZATION NAME(S) AND ADDRESS(ES) U.S. Army Research Laboratory Attn: AMSRL-SE-RM email: ggoldman@arl.mil 2800 Powder Mill Road Adelphi, MD 20783-1197			8. PERFORMING ORGANIZATION REPORT NUMBER ARL-TR-1936	
9. SPONSORING/MONITORING AGENCY NAME(S) AND ADDRESS(ES) U.S. Army Rsrch Laboratory 2800 Powder Mill Road Adelphi, DM 20783-1197			10. SPONSORING/MONITORING AGENCY REPORT NUMBER	
11. SUPPLEMENTARY NOTES ARL PR: 8NE4TD AMS code: 622120.H16				
12a. DISTRIBUTION/AVAILABILITY STATEMENT Approved for public release; distribution unlimited.			12b. DISTRIBUTION CODE	
13. ABSTRACT (Maximum 200 words) Two-dimensional inverse synthetic aperture radar (ISAR) imagery can be generated with a stationary radar illuminating a moving target. Data were collected on a 1994 Chevy Cheyenne 1500 series pickup as it was slowly pulled through a stationary radar beam to help analyze noncooperative ISAR algorithms. The speed of the vehicle varied from constant velocity to constant acceleration and the turning angle of the wheels was constant. The radar was a frequency-agile, coherent, pulsed K _s -band instrumentation radar built by the U.S. Army Research Laboratory (ARL). The data were registered optically and with stationary and rotating reflectors.				
14. SUBJECT TERMS Noncooperative, ISAR, data measurement			15. NUMBER OF PAGES 23	
			16. PRICE CODE	
17. SECURITY CLASSIFICATION OF REPORT Unclassified	18. SECURITY CLASSIFICATION OF THIS PAGE Unclassified	19. SECURITY CLASSIFICATION OF ABSTRACT Unclassified	20. LIMITATION OF ABSTRACT UL	