

JPRS 84810

25 November 1983

# USSR Report

MATERIALS SCIENCE AND METALLURGY

No. 93

**DISTRIBUTION STATEMENT A**  
Approved for Public Release  
Distribution Unlimited

19990617 179

**FBIS**

**FOREIGN BROADCAST INFORMATION SERVICE**

REPRODUCED BY  
NATIONAL TECHNICAL  
INFORMATION SERVICE  
U.S. DEPARTMENT OF COMMERCE  
SPRINGFIELD, VA. 22161

63

## NOTE

JPRS publications contain information primarily from foreign newspapers, periodicals and books, but also from news agency transmissions and broadcasts. Materials from foreign-language sources are translated; those from English-language sources are transcribed or reprinted, with the original phrasing and other characteristics retained.

Headlines, editorial reports, and material enclosed in brackets [] are supplied by JPRS. Processing indicators such as [Text] or [Excerpt] in the first line of each item, or following the last line of a brief, indicate how the original information was processed. Where no processing indicator is given, the information was summarized or extracted.

Unfamiliar names rendered phonetically or transliterated are enclosed in parentheses. Words or names preceded by a question mark and enclosed in parentheses were not clear in the original but have been supplied as appropriate in context. Other unattributed parenthetical notes within the body of an item originate with the source. Times within items are as given by source.

The contents of this publication in no way represent the policies, views or attitudes of the U.S. Government.

## PROCUREMENT OF PUBLICATIONS

JPRS publications may be ordered from the National Technical Information Service (NTIS), Springfield, Virginia 22161. In ordering, it is recommended that the JPRS number, title, date and author, if applicable, of publication be cited.

Current JPRS publications are announced in Government Reports Announcements issued semimonthly by the NTIS, and are listed in the Monthly Catalog of U.S. Government Publications issued by the Superintendent of Documents, U.S. Government Printing Office, Washington, D.C. 20402.

Correspondence pertaining to matters other than procurement may be addressed to Joint Publications Research Service, 1000 North Glebe Road, Arlington, Virginia 22201.

Soviet books and journal articles displaying a copyright notice are reproduced and sold by NTIS with permission of the copyright agency of the Soviet Union. Permission for further reproduction must be obtained from copyright owner.

4

JPRS REPORTS

Japan Report  
Korean Affairs Report  
Southeast Asia Report  
Mongolia Report

Near East/South Asia Report  
Sub-Saharan Africa Report  
West Europe Report  
West Europe Report: Science and Technology  
Latin America Report

USSR

Political and Sociological Affairs  
Problems of the Far East  
Science and Technology Policy  
Sociological Studies  
Translations from KOMMUNIST  
USA: Economics, Politics, Ideology  
World Economy and International Relations  
Agriculture  
Construction and Related Industries  
Consumer Goods and Domestic Trade  
Economic Affairs  
Energy  
Human Resources  
International Economic Relations  
Transportation

Physics and Mathematics  
Space  
Space Biology and Aerospace Medicine  
Military Affairs  
Chemistry  
Cybernetics, Computers and Automation Technology  
Earth Sciences  
Electronics and Electrical Engineering  
Engineering and Equipment  
Machine Tools and Metal-Working Equipment  
Life Sciences: Biomedical and Behavioral Sciences  
Life Sciences: Effects of Nonionizing Electromagnetic  
Radiation  
Materials Science and Metallurgy  
Meteorology and Hydrology

EASTERN EUROPE

Political, Sociological and Military Affairs  
Scientific Affairs

Economic and Industrial Affairs

CHINA

Political, Sociological and Military Affairs  
Economic Affairs  
Science and Technology

RED FLAG  
Agriculture  
Plant and Installation Data

WORLDWIDE

Telecommunications Policy; Research and  
Development  
Nuclear Development and Proliferation

Epidemiology

FBIS DAILY REPORT

China  
Soviet Union  
South Asia  
Asia and Pacific

Eastern Europe  
Western Europe  
Latin America  
Middle East and Africa

To order, see inside front cover

25 November 1983

USSR REPORT  
MATERIALS SCIENCE AND METALLURGY

No. 93

CONTENTS

ALUMINUM AND ITS ALLOYS

- Effect of Scandium on the Structure and Properties of Al-Zn-Mg Alloys  
(V. I. Yelagin, et al.; IZVESTIYA AKADEMII NAUK SSSR: METALLY, No 4, Jul-Aug 83)..... 1

COATINGS

- Initial Phases of Development of Thin Vacuum Condensates of Certain Metals  
(O. F. Gusareva, A. I. Faynshteyn; IZVESTIYA AKADEMII NAUK SSSR: METALLY, No 4, Jul-Aug 83)..... 2

CORROSION

- Influence of Atmospheric Moisture on Iron Oxidation Rate Beneath Enamel Melt Layer  
(P. I. Buler, et al.; ZASHCHITA METALLOV, No 4, Jul-Aug 83)..... 3
- Influence of Nickel Alloying on Oxidation of Titanium in Sulfur-Containing Atmospheres  
(N. V. Suntsov, et al.; ZASHCHITA METALLOV, No 4, Jul-Aug 83)..... 3
- Influence of Rarefaction of Air on Interference-Stained Oxide Film Growth Rate on VT-1 Titanium  
(V. V. Peshkov, et al.; ZASHCHITA METALLOV, No 4, Jul-Aug 83)..... 4
- Variation of Inhibiting Effect of Bipyridines and Their Hydrogen Derivatives as a Function of Configuration  
(Yu. N. Forostyan; ZASHCHITA METALLOV, No 4, Jul-Aug 83).. 5

Influence of Aluminum Metallization Coatings on Corrosion Fatigue Properties of Steel (I. N. Katkov, et al.; ZASHCHITA METALLOV, No 4, Jul-Aug 83).....	5
Influence of Parameters of Aluminum Alloy Anodizing Process on Oxide Coating Thickness (A. V. Karlashov, et al.; ZASHCHITA METALLOV, No 4, Jul-Aug 83).....	6
<b>FERROUS METALLURGY</b>	
New Ferrous Metallurgy Technology (EKONOMICHESKAYA GAZETA, No 34, Aug 83).....	7
<b>FORMING</b>	
Attempt at Manufacturing Large-Scale Stamped Forgings From Aluminum Alloys (Ye. B. Shaykevich, V. M. Mednitskiy; KUZNECHNO-SHTAMPOVOCHNOYE PROIZVODSTVO, No 8, Aug 82).....	12
Temperature Changes in Forgings of Aluminum Alloys During Their Trimming in Heated Dies (A. A. Shadskiy, V. K. Orlov; KUZNECHNO-SHTAMPOVOCHNOYE PROIZVODSTVO, No 8, Aug 83).....	12
Localization of Deformation in Hot Processing of Titanium Alloys (N. F. Anoshkin, et al.; KUZNECHNO-SHTAMPOVOCHNOYE PROIZVODSTVO, No 8, Aug 83).....	13
Certain Features of the Technology of Isothermal Stamping of Large-Scale Blanks From Titanium Alloys (F. V. Tulyankin, et al.; KUZNECHNO-SHTAMPOVOCHNOYE PROIZVODSTVO, No 8, Aug 83).....	14
Comprehensive Model Research of Kinematics of the Flow of Refractory Materials in Open Stamping of Axisymmetric Forgings (A. I. Baturin; KUZNECHNO-SHTAMPOVOCHNOYE PROIZVODSTVO, No 8, Aug 83).....	14
Pressure Gauges for Automated Control Systems for Production of Hot Pressed, Large Diameter Tubes (V. I. Pechuk, et al.; KUZNECHNO-SHTAMPOVOCHNOYE PROIZVODSTVO, No 8, Aug 83).....	15
Structure of Amorphous Powder Material $Fe_{40}Ni_{40}P_{14}B_6$ Thickened by Explosion Pressing (O. V. Roman, et al.; FIZIKA I KHIMIYA OBRABOTKI MATERIALOV, No 4, Jul-Aug 83).....	15

## GLASS AND CERAMICS

- Thermal Fatigue of Gas Turbine Engine Blades Made of Material  
Based on Silicon Nitride and Silicon Carbide  
(G. N. Tret'yachenko, et al.; PROBLEMY PROCHNOSTI, No 7,  
Jul 83)..... 16

## POWDER METALLURGY

- Development of Powder Metallurgy in Various Sections of USSR  
(P. Koblikov; SOVETSKAYA MOLODEZH', 16 Jul 83)..... 17
- Levitation Method of Obtaining Ultradisperse Metal Powders  
(M. Ya. Gen, A. V. Miller; POVERKHNOST': FIZIKA, KHIMIYA,  
MEKHANIKA, No 2, Feb 83)..... 19
- Optical Properties of Powders of Certain Refractory Compounds  
(L. A. Iyanchenko; POROSHKOVAYA METALLURGIYA, No 8,  
Aug 83)..... 19
- Influence of Boron Carbide Hot Pressing Conditions on Structure  
and Mechanical Properties  
(N. D. Rybal'chenko, et al.; POROSHKOVAYA METALLURGIYA,  
No 8, Aug 83)..... 20
- Thermophysical Properties of Various Modifications of Boron  
Nitride  
(V. L. Primachuk, et al.; POROSHKOVAYA METALLURGIYA,  
No 8, Aug 83)..... 21
- Structure, Phase Composition and Failure Character of TiC-NiTi  
Sintered Composite Materials  
(T. M. Poletika, et al.; POROSHKOVAYA METALLURGIYA,  
No 7, Jul 83)..... 21
- Research and Development of Bimetal Material by Extrusion  
(I. D. Radomysel'skiy, et al.; POROSHKOVAYA METALLURGIYA,  
No 7, 1983)..... 22
- Assemblies for Hot Isostatic Pressing of Powder Metals  
(V. A. Pavlov, B. V. Popov; POROSHKOVAYA METALLURGIYA,  
No 7, Jul 83)..... 22
- Study of Wear Resistance of Detonation Coatings Based on  
Plentiful Composite Materials  
(I. G. Nosovskiy, et al.; POROSHKOVAYA METALLURGIYA, No 8,  
Aug 83)..... 23

## REFRACTORY MATERIALS

- Serious Deficiencies Noted in Development of Refractories Industry  
(N. Mokrishchev, et al.; TRUD, 2 Aug 83)..... 24

## STEELS

- Study of the Effects of Hardening by Surface Plastic Deformation on the Development of Fatigue Fractures in 30XGCHA Steel  
(B. V. Boytsov, G. N. Kravchenko; PROBLEMY PROCHNOSTI, No 7, Jul 83)..... 27

## THIN FILMS

- Broad Range Infrared Absorption Spectra of Surface Electromagnetic Waves of Thin Films on Smooth Metal Surfaces  
(G. N. Zhizhin, et al.; POVERKHNOST'; FIZIKA, KHIMIYA, MEKHANIKA, No 2, Feb 83)..... 28
- Domain Peak Structure in Thin Ferromagnetic Films  
(A. V. Gavril'yuk, et al.; FIZIKA METALLOV I METALLOVEDENIYE, No 6, Jun 83)..... 28
- Structure and Properties of Atomized Amorphous Films of Transition Metal-Metalloid Alloys  
(N. I. Recheshter, et al.; FIZIKA METALLOV I METALLOVEDENIYE, No 6, Jun 83)..... 29

## TITANIUM

- Granular Boundary Segregation in Low-Alloyed Titanium-Vanadium Alloys  
(G. I. Kolodkina, et al.; FIZIKA METALLOV I METALLOVEDENIYE, No 1, Jul 83)..... 30
- Effect of Plastic Deformation on Phase Conversion in Age Hardening of VTZ-1 Titanium Alloy  
(M. V. Mal'tsev, N. I. Kashnikov; FIZIKA METALLOV I METALLOVEDENIYE, No 1, Jul 83)..... 31

## WELDING

- Influence of Annealing on Properties of AT3 Alloy Welded Joints  
(G. M. Shel'kov, et al.; AVTOMATICHESKAYA SVARKA, No 6, Jun 83)..... 32
- Heat Treatment of Welded Joints in OT4 and VT20 Titanium Alloys  
(M. A. Khorev, et al.; AVTOMATICHESKAYA SVARKA, No 7, Jul 83)..... 33

Strength of Welded Joints in VT23 Alloy Upon Repeated Static Loading (V. F. Topol'skiy, et al.; AVTOMATICHESKAYA SVARKA, No 7, Jul 83).....	33
Fracture Toughness Characteristics of Welded Joints in VT6S and AT6 Titanium Alloys (S. I. Yesina, et al.; AVTOMATICHESKAYA SVARKA, No 6, Jun 83).....	34
Three-Arc Welding of Straight-Seam Large Diameter Pipe With Reduced Heat Input (S. L. Mandel'berg, et al.; AVTOMATICHESKAYA SVARKA, No 6, Jun 83).....	35
Features of Laser Welding of Medium Carbon Steel Through a Cadmium Coating (A. A. Uglov, V. I. Ofer; FIZIKA I KHIMIYA OBRABOTKI MATERIALOV, No 4, Jul-Aug 83).....	35
Suppressing Porosity in Weld Joints of 1420 Aluminum Alloy (M. A. Abralov, et al.; SVAROCHNOYE PROIZVODSTVO, No 7, Jul 83).....	36
Effect of Welding Method on Corrosion Resistance of Welded Compositions Made of 1201 Alloy (N. A. Pashina, et al.; SVAROCHNOYE PROIZVODSTVO, No 7, Jul 83).....	36
Effect of Rolling Texture on Compound Formation in Diffusion Welding of Titanium Alloys (E. S. Karakazov, et al.; SVAROCHNOYE PROIZVODSTVO, No 7, Jul 83).....	37
Weldability of Aged Heat Resistant Nickel Alloys (L. I. Sorokin; AVTOMATICHESKAYA SVARKA, No 7, Jul 83)....	37
Plasma Surfacing of Bronze in Marine Machine Building (L. A. Chkalov, et al.; AVTOMATICHESKAYA SVARKA, No 7, Jul 83).....	38

MISCELLANEOUS

New Metallurgical Processes Based on High-Speed Crystallization and Diffusion of Metals (A. F. Belov; IZVESTIYA AKADEMII NAUK SSSR: METALLY, No 6, Nov-Dec 1982).....	39
--	----

Inheritance of Twin Boundaries as a Shape Memory Mechanism (G. I. Braunin, et al.; FIZIKA METALLOV I METALLOVEDENIYE, No 6, Jun 83).....	52
Stabilization of Oxide Film Growth Instability on Metal Surfaces Heated by Powerful Infrared Radiation (O. G. Buzykin, et al.; POVERKHNOST': FIZIKA, KHIMIYA, MEKHANIKA, No 10, Oct 82).....	53
Laser Alloying of U10 Steel With Chromium (V. M. Andriyakhin, et al.; POVERKHNOST': FIZIKA, KHIMIYA, MEKHANIKA, No 10, Oct 82).....	53
Effect of Deformation Rate on Deformation Reaction of Components of a Laminate (V. N. Mukhin, et al.; FIZIKA I KHIMIYA OBRABOTKI MATERIALOV, No 4, Jul-Aug 83).....	54
Diffusion of Copper in Explosively Deformed Metals (A. N. Bekrenev; FIZIKA METALLOV I METALLOVEDENIYE, No 1, Jul 83).....	54
Carbon Diffusion in an Amorphous Alloy: $Co_{70}Fe_{5}Si_{15}B_{10}$ (S. G. Urytu, P. L. Gruzin; FIZIKA METALLOV I METALLOVEDENIYE, No 1, Jul 83).....	55
Evaluation of the Role of Diffusion Creep in Superplastic Deformation (R. Z. Valiyev, V. I. Sergeyev; IZVESTIYA VYSSHIKH UCHEBNYKH ZAVEDENIY; TSVETNAYA METALLURGIYA, No 3, May-Jun 83).....	55

UDC 669'71'5'721'793

EFFECT OF SCANDIUM ON THE STRUCTURE AND PROPERTIES OF Al-Zn-Mg ALLOYS

Moscow IZVESTIYA AKADEMII NAUK SSSR: METALLY in Russian No 4, Jul-Aug 83  
(manuscript received 20 Feb 81) pp 180-183

YELAGIN, V. I., ZAKHAROV, V. V., PETROVA, A. A. and VYSHEGORODTSEVA, Ye. V.,  
Moscow

[Abstract] The durability of industrial Al-Zn-Mg alloys does not exceed 40-45 kg/mm<sup>2</sup>, and attempts to increase it by increasing zinc and magnesium content lead to increased corrosive fracturing. The present study presents results of adding scandium at the eutectic conversion temperature of 655°C. Samples of the new alloy produced by semicontinuous casting and homogenization at 460, 500, 550 and 600°C, followed by tempering in water, were examined for secondary particles containing scandium. Subsequent analysis of mechanical properties showed that scandium, especially in combination with manganese as an alloying agent, had superior durability to those alloyed using manganese as an alloying agent, had superior durability to those alloyed using manganese and zirconium. The original Al-Zn-Mg alloy showed a fully recrystallized structure which was not found with either scandium or scandium-manganese additives; the manganese-zirconium variant had a mixed structure. Thus scandium was judged to be a promising additive for production of more durable, corrosion-resistant and thermally stable Al-Zn-Mg alloys. Figures 5, references 8: 7 Russian, 1 Western.  
[168-12131]

INITIAL PHASES OF DEVELOPMENT OF THIN VACUUM CONDENSATES OF CERTAIN METALS

Moscow IZVESTIYA AKADEMII NAUK SSSR: METALLY in Russian No 4, Jul-Aug 83  
(manuscript received 2 Jun 81) pp 157-160

GUSAREVA, O. F. and FAYNSHTEYN, A. I., Odessa

[Abstract] Vaporization and condensation of metals in a vacuum to form anti-corrosion, anti-friction and heat-resistant coatings are markedly affected by residual pressure in the vacuum chamber and the degree of preheating of components that are to receive the coating. The present study reports on vaporization of titanium, chromium, copper and aluminum following a procedure to prevent impurities such as oxides from being deposited by using a semispherical metal to catch the initial, impure deposits. A photometric procedure was used to measure the thickness of the deposited coatings. Nonetheless, the coatings of 200-300 Å were found to consist of metal oxides, such as imperfect  $TiO_{0.65}$ . A "pure" metallic coating could be obtained only at 500 Å. These results were found for titanium, chromium and copper; no oxides were formed with aluminum. The results correlated with the significant difference in bonding temperatures, which was 500-550°C for the first three metals and only 200°C for aluminum. Figures 2; references 14; all Russian.  
[168-12131]

CORROSION

UDC; 620,193,2

INFLUENCE OF ATMOSPHERIC MOISTURE ON IRON OXIDATION RATE BENEATH ENAMEL MELT LAYER

Moscow ZASHCHITA METALLOV in Russian Vol 19, No 4, Jul-Aug 83  
(manuscript received 31 Mar 82) pp 654-657

BULER, P. I., IVANOVA, O. R. and ZARINA, G. R., Urals Polytechnic  
Institute imeni S. M. Kirov

[Abstract] A study is made of the influence of partial water vapor pressure in argon-water vapor and air-water vapor mixtures on the rate of oxidation of low carbon type 08kp steel beneath a layer of melted glass with the composition  $\text{Na}_2\text{O}\cdot 2\text{SiO}_2$  and  $\text{Na}_2\text{O}\cdot 2\text{B}_2\text{O}_3$ . Experiments were performed at 973-1073°K for the borate glass, 1173-1373°K for the silicate glass. Iron covered with a thin film of melted sodium silicate or sodium borate glass in an atmosphere of argon containing water vapor was found to be oxidized by the hydroxyl dissolved in the glass. The rate of oxidation increases with partial water vapor pressure from 100 to 1000 gPa. In air plus water vapor there are maxima and minima at certain values of water vapor partial pressure on the curves of oxidation rate as a function of water vapor partial pressure. This is explained by the fact that oxygen also participates in the oxidation process. Figures 3; references 5: all Russian.  
[167-6508]

UDC: 620.193.01

INFLUENCE OF NICKEL ALLOYING ON OXIDATION OF TITANIUM IN SULFUR-CONTAINING ATMOSPHERES

Moscow ZASHCHITA METALLOV in Russian Vol 19, No 4, Jul-Aug 83  
(manuscript received 11 Jun 82; after revision 10 Feb 83) pp 644-646

SUNTSOV, N. V., MILOSLAVSKIY, A. G. and ZHURAVLEV, N. L., Donetsk State  
University

[Abstract] The study was performed in mixtures of  $\text{O}_2+\text{CO}_2+\text{SO}_2$ . The oxygen partial pressure was tested by means of an electrochemical cell. X-ray and

metallographic analysis showed that when Ti+2% Ni and Ti+5% are oxidized in an atmosphere of oxygen, TiO<sub>2</sub> scale is formed. Under the present experimental conditions with CO<sub>2</sub> and SO<sub>2</sub> present, doubly ionized anion vacancies predominate in the defect structure of the TiO<sub>2</sub> and the diffusion rate of oxygen anions through these vacancies limits the oxidation process. The presence of nickel cations at low oxygen partial pressure causes an increase in  $\sigma$ , a decrease at higher partial pressures. The qualitative agreement between changes in  $\sigma$  and kinetics of oxidation of titanium alloys with nickel apparently results from the fact that in oxidation a single phase scale is formed, TiO<sub>2</sub> alloyed with nickel and sulfur. Nickel cations thus influence the electron and ion transfer in TiO<sub>2</sub> alloyed with sulfur. This creates additional capabilities for expedient modification of the rate of parabolic oxidation of titanium and its alloys, not only by changing oxygen and SO<sub>2</sub> partial pressure, but also by adding nickel cations to the scale. Figures 2; references 10: 8 Russian, 2 Western.  
[167-6508]

UDC: 669.691.2:549.943

#### INFLUENCE OF RAREFACTION OF AIR ON INTERFERENCE-STAINED OXIDE FILM GROWTH RATE ON VT-1 TITANIUM

Moscow ZASHCHITA METALLOV in Russian Vol 19, No 4, Jul-Aug 83  
(manuscript received 9 Dec 81) pp 642-644

PESHKOV, V. V., PODOPRIKHIN, M. N. and VORONTSOV, Ye. S., Voronezh Polytechnical Institute

[Abstract] A method of interference indication is used to study the influence of rarefaction of air on oxide film growth rate on technically pure type VT-1 titanium at 500-625°C, oxygen partial pressure  $3 \cdot 10^3$ - $3 \cdot 10^{-3}$  Pa. Polished, degreased specimens 15 mm in diameter and 2 mm thick were used. A furnace with an inspection window allowed continuous observation of changes in the interference coloration of the films and comparison with standard color samples. A system of vacuum pumps and a needle valve were used to maintain the assigned pressure constant during the course of the experiments. Decreasing the partial pressure of oxygen significantly decreased the rate of oxidation of titanium and the growth of oxide films, by a factor of 50 at 550°C, 75 at 625°C. In the upper area of pressures the rate of film growth is proportional to oxygen partial pressure to the 0.15 power, in the lower area--0.65 power. This indicates that the protective function of a vacuum during heating of titanium increases greatly as the partial pressure of oxygen is decreased to below  $10^{-2}$  Pa. Figures 1; references 5: 3 Russian, 2 Western.  
[167-6508]

## VARIATION OF INHIBITING EFFECT OF BIPYRIDINES AND THEIR HYDROGEN DERIVATIVES AS A FUNCTION OF CONFIGURATION

Moscow ZASHCHITA METALLOV in Russian Vol 19, No 4, Jul-Aug 83  
(manuscript received 31 Aug 82; after revision 18 Nov 82) pp 612-614

FOROSTYAN, Yu. N., Central Scientific Research and Planning-Technological Institute of Mechanization and Electrification of Animal Husbandry in the Southern USSR

[Abstract] A study is made of the influence of configuration, position of adsorption centers and ionization constants on the inhibiting effect of bipyridines and their hydroderivatives. The influence of the substances on corrosion of St3 steel in 15% sulfuric acid at 22°C with constant agitation was studied at inhibitor concentration 0.1%. Corrosion rate, inhibition factor and degree of protection were all determined from the mass loss of specimens. The inhibiting effect of bipyridines varies directly with configuration. In hydroderivatives the value of  $pK_a$  differs significantly as a function of mutual placement of amino groups in the molecules. The greater the separation of the amino groups in the molecule, the stronger the basicity of the compound and the greater the value of  $pK_a$ , inhibition factor and protection. References 12: 10 Russian, 2 Western.  
[167-6508]

## INFLUENCE OF ALUMINUM METALLIZATION COATINGS ON CORROSION FATIGUE PROPERTIES OF STEEL

Moscow ZASHCHITA METALLOV in Russian Vol 19, No 4, Jul-Aug 83  
(manuscript received 12 Apr 82; after revision 2 Aug 82) pp 596-598

KATKOV, I. N., PISTUN, I. P., KUSLITSKIY, A. B., GLEBOVA, M. A. and KOVLENKO, V. N., L'vov Agricultural Institute

[Abstract] Cylindrical specimens of OKh18N10T steel with gage section diameter 10 mm were studied for multicycle fatigue in pure flexure and bending of the specimens at 3000 cycles per minute in air and in 3.5% NaCl. The test base was  $10^7$  cycles in air,  $2 \cdot 10^7$  cycles in the corrosive medium. Short cycle endurance testing of type 45G17Yu3 steel was performed with specimens 5 mm thick, 12 KhNZA steel 25 mm thick under severe loading in the same media. Load application frequency was 10 cycles per minute, relative deformation 0.6%. The results of the testing showed that metallization with aluminum increases the corrosion fatigue strength of OKh18N10T steel. Shot peening with cast iron shot slightly increased the fatigue limit of the steel both in air and in the corrosive medium. Metallization decreased the harmful

influence of the corrosive medium in long-term fatigue testing. The short-term fatigue testing indicated that metallization with aluminum increased the durability of a specimen with stress concentrators, decreasing the negative influence of the salt solution on steel specimens. References 5: all Russian.

[167-6508]

UDC: 621.794:624.357.8

#### INFLUENCE OF PARAMETERS OF ALUMINUM ALLOY ANODIZING PROCESS ON OXIDE COATING THICKNESS

Moscow ZASHCHITA METALLOV in Russian Vol 19, No 4, Jul-Aug 83  
(manuscript received 23 Jul 82) pp 570-573

KARLASHOV, A. V., KOSINSKAYA, L. N., MASYUK, Yu. P. and GNATYUK, A. D.,  
Kiev Institute of Civil Aviation Engineering

[Abstract] The influence of technological parameters in the process of anodizing type 1420 alloy in a sulfuric acid solution on the thickness of the coating produced was analyzed by means of a second order regression model. A quasi-D-optimal rotatable box plan on a sphere was used to construct the basic model. The independent variables used included concentration of electrolyte, current density, electrolyte temperature and anodizing time. The anodizing process was performed with constant current density in a 44 dm<sup>3</sup> bath. The cathodes were lead plates. The solution was mixed by a mechanical stirrer in the center of the bath. The results showed that under the experimental conditions the influence of the primary technological parameters on thickness of the coating produced can be described by a second order equation with a high degree of accuracy over a broad range of change. Maximum effectiveness is achieved at electrolyte temperature 18°C, concentration 190 g/l. Figures 3; references 4: all Russian.

[167-6508]

## FERROUS METALLURGY

### NEW FERROUS METALLURGY TECHNOLOGY

Moscow EKONOMICHESKAYA GAZETA in Russian No 34, Aug 83 p 2

[Survey by the State Committee on Science and Technology USSR: "New Developments in Metallurgy"]

[Text] The USSR produces 28% of the world's iron ore, 21% of its pig iron and steel and 18% of its rolled products. The Ministry of Ferrous Metallurgy USSR is the main supplier of structural materials for the country's economy.

Although the volume of metal production is constantly increasing, the demand generated by machine construction and other sectors cannot be fully satisfied. One of the reasons for this situation is the imperfect structure and, in several cases, the insufficient technological level of the steel industry.

The 26th Party Congress specified that steel production is to be increased by developing oxygen process conversion and electric furnace methods, and expanding steel production through special smelting and out-of-furnace processing. These objectives form part of the scientific and technical program in the 11th five-year plan entitled "Development and assimilation of new and effective technological processes and equipment for steelmaking and out-of-furnace processing and casting."

#### EFFECTIVE PROCESSES

Research and pilot conversion carried out by scientific research institutes showed the high level of technical efficiency attained by the conversion processes with combined blow-through. While in the conventional design oxygen enters only from above, in the new method process gases are introduced from below and also from the top through tuyeres. Inert gases or oxygen can also be introduced from below, with oxygen supplied from above for blow-through and mixture with natural gas for furnace preheating. Combined blow-through makes it possible to adjust the flow rates of the molten pig iron. In addition, when the open-hearth method is replaced, it is possible to retain the proportion of molten pig iron to scrap utilized in the plant.

The program specifies that combined blow-through methods are to be introduced into the new converters shop of the Dzerzhinskiy Metallurgical Plant in 1983-84 in two variants: oxygen supply from above and below, and also oxygen

supply from below and an oxygen-fuel mixture from an upper tuyere. It is expected that the proportion of metal scrap in the charge will be raised to 35% in the first case and to 45% in the second. This indicator amounts to 25-27% for the current technology.

At the same time, at the West Siberian metallurgical combine experimental conversion is to be carried out with combined blow-through and inert gas supply entering through an upper tuyere. In this way, it is hoped to increase the proportion of metal scrap in the charge to 30%.

Scientists in this sector have also developed continuous and non-continuous conversion-type processes for steelmaking which do not use molten pig iron.

Substitution of the open-hearth method by oxygen conversion provides favorable conditions for the introduction of continuous casting and out-of-furnace steel processing, significantly improves work conditions while raising productivity, improves environmental protection against harmful discharges and eliminates manual work in difficult and injurious processes. In addition, the consumption of refractories is two times less while that of ferroalloys is one third less. Use of fuel for fusing and heating the steel bath is either eliminated or significantly reduced.

All the advantages of systematic replacement of the open-hearth method are especially apparent when out-of-furnace processing and continuous casting are introduced. In addition to economies in the steelmaking processing itself, there is an improvement in production quality with a resulting decrease in user metal consumption.

Continuous casting of steel is one of the most efficient and resource-effective technological processes in the iron and steel industry. By this means, the useful billet output from molten steel increases by 12-15%. Irreversible losses of iron as waste are reduced (45 kilograms per ton of production), the cost of pig iron casting in molds is eliminated (10-20 kilograms per ton of production), energy costs for heating casting pits are reduced, and difficult and injurious manual labor is eliminated. At the present time, about 12% of the USSR's cast steel is produced by continuous casting. During the five-year period it is intended to double this percentage.

The scientific and technical program specifies that the continuous casting process is to be introduced in 1984-85 in the Donetsk Metallurgical Plant and at Oskol Electrometallurgical Plant for alloyed structural steels for high quality pipe and section castings and for ball bearings. Systems and processes will be established for the treatment of crystallized metal by electromagnetic and electrovibratory action which, according to preliminary data, improve the macro- and microstructure of the ingots, reduce heterogeneity and raise metal density. The solution of these problems will make it possible later to pass on the experience obtained in continuous casting of alloyed steels to other electric furnace complexes.

The switch to the new method is especially important for low capacity open-hearth plants with difficult work conditions for the casting of steel in

molds with stationary channels. Here the most suitable units are horizontal-type continuous casting machines, which are easily set up in plant buildings and require significantly less capital investment. The program specifies that they are to be introduced in the Karaganda Combine and in the Uzbek, Petrovsk-Zabaykal, Sulinskiy and Omutninskiy plants.

Analysis shows that maximum productivity for the converters as well as the electric furnaces can be attained if they are used only for preparing the molten semifinished product. The finishing and adjusting for composition and temperature can be carried out expeditiously in the ladle by means of treatment with inert and active gases, by vacuum, powder-metallurgical reagents and synthetic slags with special preheating or cooling (in accordance with the purpose of the product).

In addition to raising the productivity of the units by 15-20%, out-of-furnace steel processing makes it possible to raise the output of usable metal by 8-10% by reducing rejects due to chemical composition. The metal has more homogeneous properties so that working characteristics are improved and the specific quantity of metal per product is reduced. The input of alloy falls together with that of deoxidizing agents, electric energy and fuel. The special advantage of out-of-furnace processing is in the quality and durability of metal characteristics, since the steel is free from gases and harmful impurities.

The scientific and technical program specifies, in particular, that pilots models of out-of-furnace processing of electrosteel be set up in the Donetsk Plant and that pilots for converter steel be created in the Azovstal' plant and plant imeni Dzerzhinskiy. Subsequently, it is planned to set up similar complexes in the Kuznetsk and Orsk-Khailovskiy combines now under construction, and also in converter plants which are to be brought into service to replace the open-hearth process.

A complex of this type based on domestic equipment has already been brought into production at the Azovstal' plant. Planned capacity will be attained in 1984-5. Work on two other plants is at the design or, in part, at the construction stage.

It is estimated that the satisfaction of national economic demand for metal production through the replacement of the open-hearth process by converters and electric furnaces with extensive application of continuous casting and out-of-furnace steel processing will require 20-30% less capital investment than an increase of production with the older methods.

#### INTEGRATION OF NEW METHODS

In accord with the scientific and technical program, an oxygen conversion plant with equipment allowing operation without generation of gas wastes has been brought into production at the Cherepovets Metallurgical Combine. The technology utilized here is the first in domestic and world industry for conversion of low-manganese pig iron with subsequent continuous casting and temperature and composition stabilization in the ladle. This process makes

it possible to save 35 thousand tons of manganese and 30 thousand tons of coke. Furnace productivity rose by 2.4%. The annual economic effect on the real production volume amounts to 11,7 million rubles.

In accordance with the program, and two years ahead of schedule, a continuous technological process for oxygen conversion and continuous casting of low-carbon nonageing steel and production of cold-rolled sheet steel was developed, for the first time, at the Novolipetsk Metallurgical Combine. There is a saving of 300 tons of metallic manganese and 400 tons of aluminum when comparison is made with the production of these steel qualities by the open-hearth method. The output of useful rolled products increased by 13%.

Consumers were able to replace imported metals. The annual economic effect on real production volume amounted to 48,7 million rubles.

More than one year ahead of schedule, it was possible to supply oxygen converter tuyeres with cast rather than welded heads. Five operational-industrial batches have been made and will be tested at the Yenakievskiy, Il'ich, and Azovstal' Plants. The durability of the new type of tuyere is twice as great.

#### A SOLUTION MUST BE FOUND

In spite of important successes in carrying out part of the assigned tasks, there is serious concern because of the failure to meet deadlines for specific items of great significance.

In 1984, the first horizontal-type continuous casting machines are to be brought into production; but up to the present time the Ministry of Ferrous Metallurgy USSR has not provided the necessary means for this work. Under these circumstances, it seems advisable to concentrate on the construction of a machine for one of the plants so that the acquired operational experience can be utilized at other plants.

In accordance with the program, steelmaking by electric furnace using metallized pellets on an industrial scale will be carried out at the Oskol Electrometallurgical Combine, where, in 1983, it is planned to introduce an electric furnace plant with continuous casting machines producing billets and out-of-furnace vacuum processing of molten steel. The Ministry of Heavy Engineering USSR is lagging in the planned work toward this important objective.

Introduction of continuous steel casting will take place gradually. The casting of a significant volume of ingots is reserved for the 12th and 13th five-year plans. Therefore, it is very urgent to develop the technology for casting steel in molds by means of the application of heat-insulating bearings, exothermal mixes and modernized construction of molds and casting equipment.

The plan for the 11th five-year period provided for the production of heat-insulating bearings and efficient exothermal mixes so that in 1985 twice as

much steel is to be made with these means. However, 2.5 years of the five-year plan have elapsed but the work of the Ministry of Ferrous Metallurgy USSR has not significantly advanced. An important opportunity is being lost. The available possibilities can only be realized by increasing the volume of steel made with heat-insulating bearings and efficient exothermal mixes so as to reduce the metal consumption coefficient for rolled products from 1.27 to 1.24-1.22, thus producing a saving of around 2,5 million tons of metal per year with minimal capital expenditure.

In the USSR, an original technological process for argon-oxygen refining has been developed; and a series of indicators shows that it is superior to similar systems abroad. The process makes it possible to improve chromium extraction, eliminate the use of noncarbonaceous ferrochromium when making stainless steels with low carbon contents, raise the productivity of steelmaking units by 25%, economize electricity, and substantially increase the corrosion resistance of articles and construction.

The program specifies that in 1985, the argon-oxygen refining technology is to be integrated into the Dneprospetsstal Electrometallurgical Plant at Zaporozh'ye. However, the work is progressing extremely slowly and this hinders the large-scale introduction of this highly effective process.

The Ministry of Ferrous Metallurgy USSR and the Ministry of Heavy Engineering USSR must take energetic measures in order to complete unfinished work in accordance with the program,

12497

CSO: 1842/170

FORMING

UDC 621.73.043.669.71.715

ATTEMPT AT MANUFACTURING LARGE-SCALE STAMPED FORGINGS FROM ALUMINUM ALLOYS

Moscow KUZNECHNO-SHTAMPOVOCHNOYE PROIZVODSTVO in Russian No 8, Aug 82 pp 8-10

SHAYKEVICH, Ye. B. and MEDNITSKIY, V. M.

[Abstract] The small runs of large-scale forgings lead to a number of problems that the authors address in the present study. Most of the operations are performed on relatively small hydraulic presses, resulting in part in crude distribution of metal during cutting and low productivity. Requirements for blanks include even metal distribution and good approximation of final shape. Increased thickness, permitting greater width coefficient, and control of distortions during hardening and high-speed milling, require hand correction on large-scale forgings. Technical difficulties result in the fact that less than 30% of all forgings can be delivered without corrective mechanical procedures. These operations often result in additional distortions that must be corrected before use. Plastic deformation from compression and stretching are further factors involved in producing a final product. Compression is performed at 600-800 MPa, while stretching requires much lesser force, 200-250 MPa. Examples illustrating the factors discussed are diagrammed. Figures 3, references 4; 2 Russian, 2 Western.  
[179-12131]

UDC 621.73.043.669.71.715

TEMPERATURE CHANGES IN FORGINGS OF ALUMINUM ALLOYS DURING THEIR TRIMMING IN HEATED DIES

Moscow KUZNECHNO-SHTAMPOVOCHNOYE PROIZVODSTVO in Russian No 8, Aug 83 pp 18-20

SHADSKIY, A. A. and ORLOV, V. K.

[Abstract] Production of stamped forgings from thermally hardened aluminum alloys requires corrective procedures after hardening to reduce residual tension and warping. Both temperature and deformation must be controlled

during such procedures. To determine the proper temperature, the authors developed a nomogram based on nonstationary heat exchange for a number of materials and including input of thickness, duration of heating during correction and initial temperature of forging and dies. With a cold forging, the forging stays cooler than the dies throughout the correction process. The calculations presented do not take account of thermal resistance in the layer of lubricant between the forging and the dies, so an additional formula is developed for this factor. Gradual loss of die temperature during corrective processing of several forgings is also taken into account. The calculations and confirming experimental data indicate an initial temperature need of about 200°C for thin forgings (up to 5mm), and this temperature drops to about .7 of the initial temperature by the end of corrective operations, Figures 2; references 4; all Russian.  
[179-12131]

UDC 621.73.043.295.5

#### LOCALIZATION OF DEFORMATION IN HOT PROCESSING OF TITANIUM ALLOYS

Moscow KUZNECHNO-SHTAMPOVOCHNOYE PROIZVODSTVO in Russian No 8, Aug 83 pp 24-26

ANOSHKIN, N. F., KATAYA, V. K. and KATAYA, G. K.

[Abstract] The authors hypothesized that localization of plastic deformation depends on yield limit and deformation rate. They sought to apply D. Drakker's postulate on the positive nature of constant load to define durable materials to hammer stamped forgings of titanium alloys. Increased temperature was found to correspond to reduced resistance to deformation. At lower temperature the alpha-phase quantity grew, and internal energy accumulated and contributed to loss of durability after the maximum was reached. The lower the precipitation temperature relative to the temperature of alpha+beta to beta transfer, the greater the inequality of deformation and the sharper the structural discontinuity. Deformation localizations in a two-phase titanium alloy were accompanied by deformational conversions that changed the character of the microstructure. Conditions are suggested that can prevent the occurrence of localized deformations. Figures 4; references 13; 12 Russian, 1 Russian translation from English.  
[179-12131]

CERTAIN FEATURES OF THE TECHNOLOGY OF ISOTHERMAL STAMPING OF LARGE-SCALE  
BLANKS FROM TITANIUM ALLOYS

Moscow KUZNECHNO-SHTAMPOVOCHNOYE PROIZVODSTVO in Russian No 8, Aug 83  
pp 11-13

TULYANKIN, F. V., RODINA, I. B. and PILIPENKO, A. L.

[Abstract] The authors discuss certain aspects of isothermal stamping of titanium alloys that affect the choice of thermomechanical parameters and technology for producing large-scale semimanufactured details. The requirement of heating stampings to a temperature near that of the blanks and the deviation of die temperatures by 25-35°C from nominal values will have no adverse effects if other parameters are controlled. Low speed stamping will limit deformation, and force can most easily be varied by changing deformation rate. Calculations show that higher-speed deformation can be achieved with a given force input on hydraulic presses when constant load can be maintained. The conclusions are considered to be valid for stampings of 900-2000 cm<sup>2</sup>. Figures 4; references 6: 4 Russian, 2 Western.  
[179-12131]

COMPREHENSIVE MODEL RESEARCH OF KINEMATICS OF THE FLOW OF REFRACTORY MATERIALS  
IN OPEN STAMPING OF AXISYMMETRIC FORGINGS

Moscow KUZNECHNO-SHTAMPOVOCHNOYE PROIZVODSTVO in Russian No 8, Aug 83  
pp 20-23

BATURIN, A. I.

[Abstract] The author describes production of nickel stamped axisymmetric forgings based on a model using AMG6 aluminum alloy to simulate a nickel alloy. Several marked differences between the behavior of nickel and aluminum are described and taken into account during the experiments. For example, the rate of deformation was increased in ratio to the divergence between the coefficient of temperature conductivity of the test and the production alloys. The course of stamping and shaping was followed by a method relying on deformation coordinates. Data were processed using FORTRAN on an ES-1033 computer. Components of deformation rate were found to have the greatest magnitude at the disc blade, and decreased toward the rim. While all surfaces underwent stretching, values were uneven. Stages in processing are diagrammed and summarized. Figures 5; references 5: all Russian.  
[179-12131]

PRESSURE GAUGES FOR AUTOMATED CONTROL SYSTEMS FOR PRODUCTION OF HOT PRESSED,  
LARGE DIAMETER TUBES

Moscow KUZNECHNO-SHTAMPOVOCHNOYE PROIZVODSTVO in Russian No 8, Aug 83 pp 33-35

PECHUK, V. I., ZAKHARENKOV, V. M. and GOLOVCHENKO, Yu, A.

[Abstract] Expansion of hot pressed tube production has brought with it numerous problems of automatic production control, which require precise monitoring gauges that have not been produced domestically. The speed of measuring is generally found to be insufficient for the tasks to be accomplished. In recent years Soviet instrument builders have turned to electrotransducers with tensoresistor transformers, but instability causes these gauges to lose significant amounts of the initial signal and to lack sensitivity. The authors have designed a piston-operated gauge to replace the domestic "Kristal" and "Sapfir" [Crystal and Sapphire]. Design requirements included avoidance of short-supply steels and alloys in the gauge's construction. Hermetic sealing and moisture protection permit the gauge to be used in a wide range of environments. Its accuracy was within permissible limits, and it was stable and durable in operation. Figures 2; references 8: all Russian.  
[179-12131]

STRUCTURE OF AMORPHOUS POWDER MATERIAL  $Fe_{40}Ni_{40}P_{14}B_6$  THICKENED BY EXPLOSION  
PRESSINGMoscow FIZIKA I KHIMIYA OBRABOTKI MATERIALOV in Russian No 4, Jul-Aug 83  
(manuscript received 12 Jul 82) pp 43-47ROMAN, O. V., BOGDANOV, A. P. (deceased), PIKUS, I. M., SUDNIK, L. V.,  
KRUMHOLDT, R. (of the Institute of Solid State Physics, GDR Academy of  
Sciences, Dresden), VOLOSHIN, Yu. N. and GOROBTSOV, V. G., Minsk

[Abstract] The authors investigated the possibility of using metallic glass as thin ribbons, fibers, scales and powders, as well as other applications, despite their low level of thermal stability. The effects of impact loading was tested on  $Fe_{40}Ni_{40}P_{14}B_6$  produced in Dresden by hardening from a liquid state. The samples were tested by X-ray diffractometry, differential scan calorimetry, metallography and measurement of microhardness. Temperatures produced during the impact loading by explosion were calculated to be in the broad range of 600-1400°K. Results showed that in all processes the material remained amorphous in X-rays and showed a basic heat emission peak in subsequent heating. No significant loss of amorphous state due to crystallization was noted below 800°K, but at higher loads some structural ordering took place. Explosive impact forming was judged to be an effective way to produce amorphous pressed objects. Figures 3; references 19: 14 Russian, 5 Western.  
[173-12131]

THERMAL FATIGUE OF GAS TURBINE ENGINE BLADES MADE OF MATERIAL BASED ON SILICON NITRIDE AND SILICON CARBIDE

Kiev PROBLEMY PROCHNOSTI in Russian No 7, Jul 83  
(manuscript received 24 May 82) pp 9-12

TRET'YACHENKO, G. N., KARPINOS, B. S. and KOSOV, B. D., Institute of Problems of Strength, UkSSR Academy of Sciences, Kiev

[Abstract] A study was made of the strength of ceramic turbine engine blades in relation to thermal stress and static strength features of the materials used,  $\text{Si}_3\text{N}_4$  (59.1%)+ $\text{SiC}$  (39.4%)+ $\text{MgO}$  (1.47%), at 140, 180 and 220 MPa. Effects of various temperatures up to 1373°K were registered on chrome-aluminum thermocouple meters and on tungsten-rhenium meters at 1373-1773°K, with the meters attached at diamond-cut grooves in key locations of the blades. Results showed a regular dependence of strength on temperature of operation. The heaviest loads were found at the output edges, where failure fractures consistently began. The time of thermal stress extremes was greater than the time of maximum temperature drop, and absolute values for temperature stress were basically proportional to the difference between maximum and minimum average temperature. Measurements during the cooling segment of the operational cycle showed that changes in the durability limits of the blade material simply changed the multiplier of the longevity dependence in relation to the magnitude of thermal stress at the output blade edge. The hypotheses generated were confirmed by statistical analysis. Figures 7; references 3: all Russian.  
[160-12131]

## POWDER METALLURGY

### DEVELOPMENT OF POWDER METALLURGY IN VARIOUS SECTIONS OF USSR

Riga SOVETSKAYA MOLODEZH' in Russian 16 Jul 83 p 2

[Article by P. Koblikov: "Metallurgy of the Future"]

[Text] A thematic exhibition, "The Development of Powder Metallurgy in Regions of the Country," has been on display in the Chemistry pavillion at the Exhibition of USSR National Economic Achievements (VDNKh). Its exposition clearly illustrates the successes in the work of Soviet scientists on the All-Union Joint program, "Powder Metallurgy, Composite Materials and Coatings." Academic institutes and over 200 scientific-research, planning-design organizations, and enterprises from all the union republics have cooperated in it.

In the opinion of specialists, our country currently occupies a leading place in the world in powder metallurgy. The production of components made of powder has expanded considerably. The production of specialized equipment, means of automation, presses, roasting furnaces, and monitoring and testing equipment has also increased. In the current Five-Year Plan alone, great production capacities for producing iron powder have been introduced in the plant in Brovary near Kiev, which is the largest in Europe, in a number of enterprises of the Dnepropetrovsk and Donetsk Oblasts, in the Krasnyy Sulin Plant of the Rostov Oblast, in the Tula Ferrous Metallurgical Association, and in Belorussia.

Approximately 15 types of technological processes for producing products from powders of iron, copper, other metals and their alloys have been developed and approved. They are used more often in the production of construction and electrotechnical products, hard alloy instruments and anti-friction materials. Models of them are displayed at the exhibition.

It is significant that plans with widespread direct collaboration of specialists with collectives where the scientists' newest developments are introduced, such as the Moscow Powder Metallurgical Plant and enterprises which produce instruments using powders in a number of other cities in the country, are being carried out more actively.

Specifically, industry is more willing to use the new superhard material, hexanite-R, which was developed by Ukrainian specialists. It is used for the

production of an instrument which, without exaggeration, cuts everything. The cutter's hexanite part, which was successfully joined firmly to the basic part of the cutting instrument, works so actively that, as a result of sharpening, it is almost unnecessary to polish. Labor productivity is increased tenfold.

The output of hexanite cutters is increasing in the 11th Five-Year Plan. Collectives producing hard alloy instruments in the Ukraine, Armenia and other regions have already made a great contribution to increasing its output volume. In addition, this novelty alone has saved the country tens of millions of rubles and freed thousands of machines for other operations.

The above-mentioned joint program opens up great prospects for mass introduction of coatings which protect metal products from corrosion and protect machine parts from deterioration. The following facts attest to the great effectiveness of such technological operations: the fatigue life of the protected surfaces has increased 5 to 10-fold; costs have dropped sharply; the weight of machines and equipment has decreased, and their dependability has increased.

A special division of the thematic exhibition is devoted to the advances of the Belorussian Scientific-Industrial Association of Powder Metallurgy. Its special feature is the fact that it is built on an intersectorial basis. The association serves the enterprises of Belorussia and the Baltic republics. In just the past year, the economic effect from the developments of the Belorussian Scientific-Industrial Association of Powder Metallurgy exceeded 10 million rubles. It will become considerably larger in 1984, when the Molodechnenskiy Metallurgical Plant will go into operation.

As the exposition indicates, today it is impossible to do without powder metallurgy in the production of diamond instruments. For example, a method developed at the Institute of Problems of Material Science of the Ukrainian SSR Academy of Sciences and organized in Armenia makes it possible to produce diamond cutting wheels without a steel frame. And this means that they are able to work until they deteriorate completely; in addition, steel alloys are economized. As a result, labor productivity is sharply increased, and material costs are decreased.

In recent years, fruitful contacts have been made between Armenian scientists and designers and the Institute of Solid State Physics of the USSR Academy of Sciences. As a result of creative collaboration, a design for outfitting a high-pressure device to produce hexanite-R blanks with diameters up to 15 millimeters has been developed. A model of this device is on display at one of the stands.

The exhibition also tells in detail about the successes of scientists and specialists of the Electric Welding Institute imeni Ye. O. Paton of the Ukrainian SSR Academy of Sciences, the Moscow Higher Technical School imeni N. Ye. Bauman, the Remdetal' Scientific Industrial Association, the State Committee of Agricultural Equipment, VUZ's and plants of the country in developing powder metallurgy.

12478

CSO: 1842/172

UDC 541.182.024

LEVITATION METHOD OF OBTAINING ULTRADISPERSE METAL POWDERS

Moscow POVERKHNOST': FIZIKA, KHIMIYA, MEKHANIKA in Russian No 2, Feb 83  
(manuscript received 19 Apr 82) pp 150-154

GEN, M. Ya. and MILLER, A. V. (deceased), Institute of Chemical Physics,  
USSR Academy of Sciences, Moscow

[Abstract] One of the main drawbacks to producing ultradisperse metal powders by a continuous process is the need for a vaporizing device that will hold up during high-temperature operations (1000-3000°C). The present study seeks to solve that problem by using a heated high-frequency electromagnetic field to suspend metal droplets in inductors. An experimental dependency was established between the temperature of a drop of aluminum and its diameter with constant high-frequency generator operation. An inert gas and atmospheric pressure or below prevented metal adhesion to the walls of the vaporizing chamber; minimum gas flow rate was determined by Einstein's formula  $\bar{x}^2 = 2Dt$ . Combined control of pressure, gas type and gas flow made it possible to change the average dimensions of metal particles from tens to thousands of angstroms. The method described has been used to obtain such particles of lithium, tin, aluminum, cobalt, gadolinium and various systems such as Fe-Co, Fe-Ni and Cu-Ag. Figures 5; references 17: 15 Russian, 2 Western.  
[162-12131]

UDC: 621.762

OPTICAL PROPERTIES OF POWDERS OF CERTAIN REFRACTORY COMPOUNDS

Kiev POROSHKOVAYA METALLURGIYA in Russian No 8, Aug 83  
(manuscript received 25 Aug 82) pp 66-73

IVANCHENKO, L. A., Institute of Material Science Problems, Ukrainian  
Academy of Sciences

[Abstract] The parameters which must be known concerning the component powders used to manufacture materials for electronics and other areas by

powder metallurgy can be determined comparatively easily and rapidly by analysis of the reflectivity of the materials. This article describes investigation of powders in the area of the edge of fundamental absorption and the area of interaction of light with the crystalline lattice as well as with free charge carriers for BN, ZrC, NBC, TaC and WC, as well as zirconium borides of two compositions in the 0.2-25  $\mu\text{m}$  spectral area. BN powders of various structural types are used to show that the results of measurement of reflectivity at the edge of natural absorption (UV) and in the area of interaction of light at the lattice (IR) allows judgements to be made concerning the presence of impurities in the specimens, the type of crystalline structure and several crystal parameters. The study of the optical reflectivity of powders can be considered a method of testing the phase composition and a rapid method of preliminary determination of certain physical parameters such as the width of the forbidden zone, conductivity, dielectric permeability, free charge carrier concentration, etc. Figures 6; references 16: 14 Russian, 2 Western,  
[180-6508]

UDC: 539.4.0155,661,665.3;621.762.5

#### INFLUENCE OF BORON CARBIDE HOT PRESSING CONDITIONS ON STRUCTURE AND MECHANICAL PROPERTIES

Kiev POROSHKOVAYA METALLURGIYA in Russian No 8, Aug 83  
(manuscript received 24 Aug 82) pp 39-43

RYBAL'CHENKO, N. D., MORONOVA, A. G., PODTYKAN, V. P., OSTAPENKO, I. T., OSIPOV, A. D. and TARASOV, R. V., Khar'kov Institute of Physics and Technology, Ukrainian Academy of Sciences

[Abstract] The purpose of this work was to study the influence of hot pressing conditions (temperature and pressure) on the formation of the microstructure (porosity, grain size) and mechanical properties (hardness, bending and compressive strength) of boron carbide. The initial  $\text{B}_4\text{C}$  powder was obtained by synthesis from its elements with a specific surface of 5.5-7.5  $\text{m}^2/\text{g}$ , mean particle diameter 0.3-0.4  $\mu\text{m}$ . The microstructure of the specimens was studied by electron microscopy. Pressure was found to influence grain size significantly in the 2373-2473°K temperature interval, a pressure of 37.5 MPa producing grains not over 3  $\mu\text{m}$  in diameter. As temperature increases, increasing pressure yields approximately constant increases in density due to reduced porosity up to 2373°K. Above this temperature porosity does not vary with pressure. The hardness of specimens obtained at over 30 MPa depends little on temperature. Compressive strength increases monotonically with increasing temperature up to 2373°K and is proportional to increasing pressure up to 37.5 MPa. Increasing temperature to 2473°K produces a decrease in specimen strength. Figures 4; references 4: 3 Russian, 1 Western.  
[180-6508]

## THERMOPHYSICAL PROPERTIES OF VARIOUS MODIFICATIONS OF BORON NITRIDE

Kiev POROSHKOVAYA METALLURGIYA in Russian No 8, Aug 83  
(manuscript received 16 Sep 82) pp 80-82

PRIMACHUK, V. L., BOCHKO, A. V. and AVETISYAN, A. O., Institute of Material Science Problems, Ukrainian Academy of Sciences

[Abstract] A study is made of the heat conductivity of polycrystalline materials based on boron nitride in the area of their thermal stability at 400 to 1000°K. Experiments were performed on compact polycrystalline specimens of elbor-R and hexanite-R with various ratios of sphalerite, wurzite-like and graphite-like phases. The heat conductivity coefficient was determined on an installation designed to study the heat conductivity of materials with metallic conductivity, modified to allow measurement by a stationary comparative method of the dielectric specimens studied. The difference in heat conductivity coefficients of polycrystalline elbor and hexanite specimens is explained by the difference in grain size of BN<sub>sph</sub>. Electron photomicrographs are presented of the specimens, indicating that the BN<sub>sph</sub> grain size is several times larger in elbor than in hexanite. It is concluded that the main reason for the difference in heat conductivity coefficient is the crystal size, which depends on the technology and synthesis conditions and may vary over broad limits. Figures 3; references 8: all Russian.  
[180-6508]

UDC 621.762:669.018.95

## STRUCTURE, PHASE COMPOSITION AND FAILURE CHARACTER OF TiC-NiTi SINTERED COMPOSITE MATERIALS

Kiev POROSHKOVAYA METALLURGIYA in Russian No 7, Jul 83  
(manuscript received 21 Jun 82) pp 54-59

POLETIKA, T. M., KUL'KOV, S. N. and PANIN, V. Ye., Institute of Atmospheric Optics, Tomsk Branch, Siberian Division, USSR Academy of Sciences

[Abstract] To test possibilities of reducing the brittleness of compositions of refractory compounds and transitional metals, as well as improving other parameters, the authors studied the intermetallic compound NiTi, which features a martensite conversion, good plasticity and high impact resistance and creep limits. The sintering process, phase composition and failure features of TiC-NiTi materials were studied through a wide range of solid phase-bonding phase ratios using metallography and electron fractography. With 10-40% NiTi, solid phase baking was the key factor, while with 40% NiTi the carbide granules (averaging 2-3 mkm) were quite irregular in distribution. With 40-70% NiTi trans-crystallization by a dissolution-precipitation mechanism was common. In this mechanism there was constant

redistribution of Ti atoms in the direction of carbide. Electron microscopic examination of surface fragments showed that failure was largely dependent on the amount of NiTi in the alloy. With 40% or less NiTi, failure occurred mainly at carbide granule boundaries and in transcrystalline locations. With 40-60% NiTi, fractures came at the boundaries between small carbide and large-grain facets. The desired damping effect was found only in alloys with 30% or less NiTi. Figures 5; references 4: 3 Russian, 1 Western.  
[175-12131]

UDC 621.762

#### RESEARCH AND DEVELOPMENT OF BIMETAL MATERIAL BY EXTRUSION

Kiev POROSHKOVAYA METALLURGIYA in Russian No 7, 1983 pp 47-50

RADOMYSEL'SKIY, I. D., KEMURDZHIAN, A. L., MANUKYAN, N. V.,  
ROZENTSVEYG, I. I. PETROSYAN, Kh. L., SHEPEL', S. A. and AKOPOV, N. L.,  
Institute of Problems of Material Science, UkSSR Academy of Sciences;  
Yerevan Polytechnical Institute

[Abstract] Procedures for producing a durable bimetallic iron-silicon extrusion with an inner titanium alloy layer are described. An important factor in determining composition was selection of the barrier material between titanium and iron; of several tested, vanadium and molybdenum were most practical, and the final selection was Mo because of its superior plastic qualities. Procedures for carbonizing the steel and establishing the steel matrix are summarized. Alpha-gamma conversion in the iron, and the need to provide rapid graphite dissolution and prevent burning of the jaws determined the annealing temperature of 600°C, which provided the greatest durability. High-frequency annealing was selected instead of conventional heat treatment. Figures 1; references 4: all Russian.  
[175-12131]

UDC 621.762.4

#### ASSEMBLIES FOR HOT ISOSTATIC PRESSING OF POWDER METALS

Kiev POROSHKOVAYA METALLURGIYA in Russian No 7, Jul 83  
(manuscript received 12 Apr 83) pp 47-50

PAVLOV, V. A. and POPOV, B. V., Zaporozh'ye Machinebuilding Institute

[Abstract] Methods and assemblies for hot isostatic pressing use either inert gases, such as helium, argon or nitrogen, or liquids, including water, oil, melted metals, glass or salts, as pressure media. The present study describes various types of isostats and methods of heating charges. Both pressure and threaded closures are used. Charges generally are heated outside

the isostat to conserve machine time and increase process productivity. Chamber pressure is established either by the drive device or in several stages, including drive and heating. The assemblies are described and calculations of effectiveness presented. Required wall thicknesses and bushing design are diagrammed. Figures 5; references 7: all Russian.  
[175-12131]

UDC: 621.762

#### STUDY OF WEAR RESISTANCE OF DETONATION COATINGS BASED ON PLENTIFUL COMPOSITE MATERIALS

Kiev POROSHKOVAYA METALLURGIYA in Russian No 8, Aug 83  
(manuscript received 24 Aug 82) pp 85-87

NOSOVSKIY, I. G., KADYROV, V. Kh., KOTLYARENKO, L. A. and SHCHEPETOV, V. V.,  
Institute of Material Science Problems, Ukrainian Academy of Sciences

[Abstract] The authors studied the properties of powder compositions, type PKh23N15 stainless steel and PKh20N80 nichrome, as replacements for tungsten-containing hard alloys such as tungsten carbide traditionally used for atomization of wear resistant coatings. The materials tested were alloyed with boron and aluminum by combined diffusion saturation, and detonation-gas atomization was performed using the equipment and technology developed at the Institute of Material Science Problems, Ukrainian Academy of Sciences. The process produced coatings 0.18-0.20 mm thick after grinding, surface roughness 0.63-0.32, bond strength with substrate 80-100 MPa. The results showed that the composite coatings based on alloyed nichrome powder had higher wear resistance under dry friction conditions in air. These studies showed that detonation coatings of stainless steel and nichrome alloy powders are practically equal in wear resistance to tungsten-containing VK15 powders and can be successfully used in dry friction couples. Figures 4; references 3: all Russian.  
[180-6508]

## REFRACTORY MATERIALS

### SERIOUS DEFICIENCIES NOTED IN DEVELOPMENT OF REFRACTORIES INDUSTRY

Moscow TRUD in Russian 2 Aug 83 p 2

[Article by N. Mokrishchev, I. Ostrovskiy, correspondents for Trud, and S. Prokopchuk: "The Time Factor: What Is Slowing the Development of the Refractories Industry"]

[Text] Metal is the bread of industry, the foundation of the economy. Today the Soviet people are proud of the fact that the USSR is first in the world in the smelting of steel. This is a point of historical importance. Resolving this task has meant solving a multitude of highly complex problems connected with the development of metallurgy. These include setting up mines and quarries, building batteries of coking ovens, and developing the refractories industry and erecting blast furnaces and open-hearth furnaces, etc.

In essence, each of these areas is a complete and independent branch of industry. But they are all interrelated, and the development of metallurgy depends on each of them. Let us take, for example, the refractories industry. Without these materials, which can withstand incandescent gases and molten metal, it is impossible to produce steel. Dozens of specialized plants produce many millions of tons of refractories. Our country is first in the world in their production as well. During the past five-year plan the production of high-quality refractory materials increased.

The successes, as they say, are there for all to see, and yet serious deficiencies are discernible in the refractories industry. A shortage of these materials is being felt. Every metallurgical plant should have a strictly defined minimum of refractories, a so-called "non-reducible reserve." By the middle of April this reserve had fallen in Ukrainian enterprises, for example, to a very low level--there was not even half the quantity specified by the norm.

Now we come to one of the most important and crucial problems--rates of technological retooling. These are lagging behind the requirements of the time and are significantly lower than in other branches of industry, or, to be more precise, sub-branches of ferrous metallurgy. In many refractory plants along with new technology there is a great amount of unproductive and obsolete equipment. According to data from the All-Union Refractories Institute, about half of the basic technical equipment does not meet modern scientific and technological standards, and more than 20% of products are roasted in outdated furnaces.

This also explains the slow reduction in the percentage of workers involved in heavy manual labor. The proportion of these in the refractories industry is higher than the branch average. The amount of manual labor used in repair work is especially great.

Other examples could be adduced as well, but already this much is clear: the technological retooling of the refractories industry is one of the most crucial problems. Its solution should be given primary attention by metallurgists themselves, mechanical engineers, planning agencies, and, of course, builders. All, to one degree or another, bear the responsibility for the condition of the refractories industry. Capital investments for its development, unfortunately, are being made without regard for its needs, but even these investments are generally not well used. This can be seen from examples from both the past five-year plan and the first two years of the present one.

Fifteen years ago, for example, the Borovich Refractories Combine began construction of a shop for steel-casting supplies. But the construction has not been finished in this period; not all efforts have been applied. The Kazakh Alumino-Silicate Refractories Plant in the town of Rudnyi, Kustanay Oblast, has been under construction for seven years, and completion is not in sight.

Meanwhile, much also depends on the metallurgists themselves. Let us return to questions of construction. As we know, everything begins here with a plan. But the quality of many plans leaves a great deal to be desired. For example, serious deficiencies were overlooked by the All-Union Refractories Institute of the USSR Ministry of Ferrous Metallurgy in the planning of one of the shops at the Zaporozh Refractories Plant. The equipment designed by this institute proved to be nonfunctional. It took one and a half years after the introduction of this equipment to correct the designers' errors and start production...

A no less serious reproach could be given the institutes and industrial associations for the slow development in the production of new kinds of refractories. We are speaking in particular of such advanced materials as refractory concrete,

As early as 1978 the board of the USSR Ministry of Ferrous Metallurgy passed a resolution to raise the level of the use of refractory concrete to 25% in the years immediately ahead. Today we have reached a level of only 4.6%--much less than in some industrially developed countries. What is hindering the widespread application of this advanced innovation?

First of all there are no designs for furnaces made of such concrete, although there has been quite sufficient time for their development. Also, much specialized machinery has not been built. As a result, brick continues to be widely used, while the quality of some varieties of brick is not improving but deteriorating. Let us state that the average durability of the roofs of 96 to 67 melts; for walls the figure has dropped from 165 to 156. It is clear that this situation demands more and more refractories of various types. It is a vicious circle. Improving product quality and introducing new materials--this is the way out of that circle.

The problem is exacerbated by the absence of modern equipment. Not one plant in the country produces equipment for the refractories industry. Many items, right down to bucket wheel excavators, are built by metallurgists in their primitive workshops,

It appeared that things were taking a turn for the better in 1977. After long negotiations, threatening orders and resolutions the Ministry of Ferrous Metallurgy and the Ministry of the Machine Tool Industry set a timetable for the production of new presses in the period 1978-1982.

"But our excitement was premature," says V. Chegonenko, chief maintenance engineer at the "Ukrogneupornerud" Association. "There are ten checkpoints in the timetable; nine have not been reached."

In conclusion we would like to name one more very important reserve which is at present poorly utilized--careful use of refractory goods. Heavy losses have been occurring during storage and transportation. About a third of them are shipped in bulk rather than in packages or containers; as a result, much of this valuable and expensive material is damaged and has to be repaired or simply thrown out. The loss is no less serious at warehouses, where approximately 30% of refractories are stored outdoors. In one year alone the Magnitogorsk Metallurgical Combine had to write off more than 2,500 tons of refractory goods, the "Azovstals" Plant, 1,500 tons. Every year almost 8% of hard-to-produce siphon goods are damaged and written off in the metallurgical plants of the Ukraine. The total loss of refractories enroute from the manufacturing plant to the furnaces where they are used comes to a truly astronomical figure--a half million tons a year.

How can we interest transport workers and metallurgical enterprises in being more careful and zealous in their treatment of such valuable and essential materials? Obviously, first of all through the use of economic levers. Perhaps it would be worthwhile to raise the price of refractories and develop a system of compensation of losses in cases where refractories are damaged--whether it is a brigade of loaders, transport workers, warehouse or metallurgical shop workers. Perhaps there are some other means. But we can no longer put up with the annual loss of so much refractory material that is so necessary for metallurgists.

As we can see, only a composite approach to these pressing problems will permit a significant acceleration in the development of the refractories industry. The central planning organs have recently determined a number of serious measures for the development of the refractories industry and the replacement of obsolete equipment with equipment that is more advanced and more highly productive. It is a matter of honor for machine builders to fulfill these tasks in a complete and timely fashion. We must stress that the time factor here is especially important. In the final analysis we are dealing with the progress of our entire ferrous metals industry.

12488

CSO: 1842/164

STEELS

UDC 539.4:621.787

STUDY OF THE EFFECTS OF HARDENING BY SURFACE PLASTIC DEFORMATION ON THE DEVELOPMENT OF FATIGUE FRACTURES IN 30XGCHA STEEL

Kiev PROBLEMY PROCHNOSTI in Russian No 7, Jul 83  
(manuscript received 16 Jun 83) pp 24-27

BOYTSOV, B. V. and KRAVCHENKO, G. N., Moscow Aviation Institute

[Abstract] Citing modern design needs for steel that will undergo fatigue fractures during operation without sudden failure, tests were made of 30KhGSNA steel samples 7.5 mm in diameter that were heat-tempered to HRC 44...45. The samples were subjected to cyclic loads at about 70 Hz in a range of 650-950 MPa. The automatic oscillation of the input device made it possible to fix the moment of initial fracture formation both on the surface and at some depth in the metal. Polishing, vibration-hardening, rolling and several hammering processes were used to harden the samples. Fatigue results were processed statistically using the Paris equation. Figures 2; references 8: all Russian.  
[160-12131]

THIN FILMS

UDC 535.34;539.211

BROAD RANGE INFRARED ABSORPTION SPECTRA OF SURFACE ELECTROMAGNETIC WAVES OF THIN FILMS ON SMOOTH METAL SURFACES

Moscow POVERKHNOST': FIZIKA, KHIMIYA, MEKHANIKA in Russian No 2, Feb 83 (manuscript received 1 Jun 82) pp 44-50

ZHIZHIN, G. N., MOSKALEVA, M. A., SIGAREV, A. A. and YAKOVLEV, V. A.,  
Institute of Spectroscopy, USSR Academy of Sciences

[Abstract] Molecular oscillation spectroscopy, despite its effectiveness in studying diverse materials, is limited by its small optical signal and poor signal-noise ratio. The current study presents results of surface electromagnetic wave- and reflective absorption spectroscopy as an alternative to the above method, based on tests of dimethyldichlorosiloxane on (DMDCS) and 4-n-octadecylphenol (ODP), both applied as thin films on copper, with monolayers of molecules of 1 to 17. The two spectroscopic methods examined a three-ply system of air, the dielectric film and the semicontinuous metal. The surface electromagnetic wave (SEW) method was found to increase in sensitivity as the distance between transformational elements grew, while both methods became more sensitive with increasing film thickness. The optical density of absorption bands differed markedly, and it was judged that SEW spectroscopy was 10 times more sensitive than reflective absorption (RA) spectroscopy. Figures 4; references 16: 8 Russian, 8 Western.  
[162-12131]

UDC: 539.216.2;538.221;620.187.3

DOMAIN PEAK STRUCTURE IN THIN FERROMAGNETIC FILMS

Sverdlovsk FIZIKA METALLOV I METALLOVEDENIYE in Russian Vol 55, No 6, Jun 83 (manuscript received 31 Aug 82) pp 1221-1223

GAVRILYUK, A. V., KARABANOVA, V. P., PANAETOV, V. P., POPOV, V. I. and POPOV, V. N., Irkutsk Pedagogic Institute

[Abstract] The results of a study of the structure of the peaks of flat magnetic domains are discussed. The structure largely determines the quasi-static and dynamic properties of the domains. Studies were performed by

electron microscope and powder methods on magnetic films with a composition of 20% Fe- 80% Ni. The equilibrium magnetic state was studied, influence of quasistatic fields on domain restructuring processes considered and the variation of the structure of the apex as a function of equiaxial anisotropic constants, magnetic saturation of the magnetic medium and film thickness was determined. Figures 1; references 5: all Russian.  
[159-6508]

UDC: 669.018.54:539,216.2:539.213

STRUCTURE AND PROPERTIES OF ATOMIZED AMORPHOUS FILMS OF TRANSITION METAL-METALLOID ALLOYS

Sverdlovsk FIZIKA METALLOV I METALLOVEDENIYE in Russian Vol 55, No 6, Jun 83  
(manuscript received 27 Jul 82) pp 1213-1215

RECHESHTER, N. I., BADINTER, Ye. Ya., YAKUNIN, A. A., BASHEV, V. F. and MIROSHCHNICHENKO, I. S., Dnepropetrovsk State University imeni the 300th Anniversary of Joining of the Ukraine with Russia

[Abstract] The purpose of this work was to determine the composition and conditions of atomization required to produce thin films of transition metal-metalloid alloys with amorphous structure and to compare the structure and electric properties of atomized films with foils hardened from the liquid state with amorphous structure. Rapidly cooled specimens were produced by spraying droplets of the melt in a jet of compressed inert gas onto the inner surface of a rapidly spinning copper cylinder and by ion-plasma atomization. The thermal stability and kinetics of decomposition of the amorphous phase were determined by recording electrical resistance polytherms. The stability of atomized amorphous films over time was determined by measuring the surface resistance before and after 100 hours' holding at 125°C. It was found that the relative change in surface resistance depends on the value of surface resistance. After low temperature holding the surface resistance is increased. This results primarily from surface oxidation of the atomized films. Figures 1; references 3: all Russian.  
[159-6508]

## TITANIUM

UDC 669.295'292:620.186.2

### GRANULAR BOUNDARY SEGREGATION IN LOW-ALLOYED TITANIUM-VANADIUM ALLOYS

Sverdlovsk FIZIKA METALLOV I METALLOVEDENIYE in Russian Vol 56, No 1,  
Jul 83 (manuscript received 10 Oct 82) pp 160-164

KOLODKINA, G. I., KRYUKOVA, I. I., RYBNIKOV, A. I. and USHKOV, S. S.,  
Scientific Production Association for Research and Planning Energy  
Production Equipment imeni I. I. Polzunov

[Abstract] Previous problems with brittleness of titanium-aluminum alloys were attributed to segregation of impurities such as nickel and iron on granular boundaries at high temperatures. The present study sought to test the hypothesis that this phenomenon is related to polymorphic conversion of the titanium. The test alloy contained up to 2.0% (by weight) vanadium. Formed into 15 mm diameter rods, it was annealed at various temperatures for 500 hours, then tested for brittleness. At nearly 500°C and 1-2% vanadium, brittleness was eliminated. After annealing at 850°C, impact strength declined markedly in comparison with that in the initial state and after processing at 700 and 900°C. Embrittlement was found where the solubility of vanadium in alpha-titanium was minimal, while "500° embrittlement" disappeared. Alloying and impurity elements were well distributed in all tested alloys. Particles found included iron alone, iron and vanadium, and iron, vanadium and nickel combinations. At higher temperatures, the bonds between metals were found to be unstable. The key factor in segregation was judged to be the energy suitability for a dissolved element in an alpha-solid solution. Temperature ranges for formation of granular boundary segregation were determined by the possibility of thermodynamically suitable phase presence in the range and approached the temperatures of alpha-beta or eutectoid conversions. Figures 4; references 10: all Russian.  
[174-12131]

EFFECT OF PLASTIC DEFORMATION ON PHASE CONVERSION IN AGE HARDENING OF VTZ-1  
TITANIUM ALLOY

Sverdlovsk FIZIKA METALLOV I METALLOVEDENIYE in Russian Vol 56, No 1,  
Jul 83 (manuscript received 23 Jul 81) pp 110-114

MAL'TSEV, M. V. and KASHNIKOV, N. I., Gor'ky Polytechnical Institute  
imeni A. A. Zhdanov

[Abstract] The authors compare processes taking place during deformation and subsequent heating for VTZ-1 alloy tempered in the mechanically unstable beta-phase, with those of undeformed samples. A martensite beta $\leftrightarrow$ alpha" conversion and the direction of beta-phase lines are discussed. With heating both alpha" and beta phases decomposed, and a reverse conversion of alpha" into beta occurred. Further heating led to the decomposition of the beta phase as well. Where small degrees of deformation were applied, phase conversions during constant heating were analogous to those in the undeformed alloy, but with increased deformation, low-temperature reverse martensite conversion was suppressed. This prevented the stage of beta-phase delamination and subsequent beta-alpha" conversion in depleted portions of the beta-phase. Figures 3; references 3: all Russian.  
[174-12131]

## INFLUENCE OF ANNEALING ON PROPERTIES OF AT3 ALLOY WELDED JOINTS

Kiev AVTOMATICHESKAYA SVARKA in Russian No 6, Jun 83  
(manuscript received 15 Sep 82; in final form 7 Dec 82) pp 53-55, 66

SHELENKOV, G. M., candidate of technical sciences, TROYANOVSKIY, V. E., engineer, Sum. Machine Building Production Association imeni M. V. Frunze, BLASHUK, V. Ye., candidate of technical sciences, ONOPRIYENKO, L. M., and BOYEVA, G. Ye., engineers, Institute of Electric Welding imeni Ye. O. Paton, Ukrainian Academy of Sciences, MELEKHOV, R. K., candidate of technical sciences, Institute of Physics and Mechanics, imeni G. V. Karpenko, Ukrainian Academy of Sciences

[Abstract] Residual stresses can add with operating stresses and decrease the resistance of seams to delayed fracture. Heat treatment, decreasing residual stresses in welded joints of titanium alloys, decreases the total stress level and danger of cold cracking. The major structural material for the manufacture of hydrolytic apparatus operating in sulfuric acid is AT3 pseudo  $\alpha$  alloy, alloyed with aluminum and small quantities of  $\beta$  stabilizing elements such as chromium, iron and silicon. To maintain good welded joint properties in hydrolytic apparatus, a technology of welding and heat treatment must be developed. The interaction of titanium with oxygen increases at 700°C and higher, hydrogenation beginning at 500 to 600°C and increasing with increasing temperature and humidity. The purpose of this work was to establish the influence of annealing temperature in the 500 to 900°C temperature range on properties of AT3 alloy and its welded joints and determine heat treatment conditions providing optimal combinations of properties. Tests were performed on specimens made of hot rolled sheets of AT3 alloy 25 mm thick. Joints were butt welded in argon with lanthanum treated tungsten electrodes manually with X-shaped finishing of edges following mechanical working of the edges, washing with gasoline and ethyl alcohol. Annealing at 650°C provides the best combination of strength and ductility while practically not changing the content of gases in the alloy. The impact toughness decreases from 95 to 72 J/cm<sup>2</sup> under these conditions, fatigue strength from 330 MPa to 180 MPa. The best combination of strength and ductility properties is thus produced by annealing at 650°C, which reduces residual welding stresses and decreases the danger of corrosion cracking. Figures 3; references 3: all Russian. [152-6508]

## HEAT TREATMENT OF WELDED JOINTS IN OT4 AND VT20 TITANIUM ALLOYS

Kiev AVTOMATICHESKAYA SVARKA in Russian No 7, Jul 83  
(manuscript received 10 Nov 82; in final version 4 Feb 83) pp 19-23

KHOREV, M. A., engineer, GUSEV, Yu. V. and GRIBOVA, N. K., candidates of technical sciences, Moscow

[Abstract] The purpose of this work was to determine the influence of heat treatment conditions over a broad range of heating temperatures on the mechanical properties of welded joints in pseudo- $\alpha$  alloys and to estimate the possibility of increasing their strength. An attempt was also made to analyze the thermal instability of pseudo- $\alpha$  alloys in the process of low temperature heating up to the aging temperature after rapid quenching in water. The mechanical properties of welded joints in specimens 3 mm thick made by mechanized argon-arc welding without additive wire were studied. Heat treatment was performed in furnaces in air with cooling in air, in water and in a vacuum furnace. The change in mechanical properties upon quenching in water with subsequent aging was estimated. Heat treatment conditions are suggested to provide good ductility of joints with moderate strength or increased strength with moderate ductility. It is noted that it is possible to strengthen welded joints in OT4 alloy by hardening from 850 to 900°C and aging at 400°C, 4 hours, in VT20 alloy by hardening from 900°C and aging at 400°C, 4 hours. Hardening of welded joints in pseudo- $\alpha$  alloys by hardening and aging is, however, ineffective, since strength increases by only 10% to 18%, while ductility is reduced. Quenching of welded structures causes significant warping as well, producing great difficulties in industrial performance of the process. Figures 4; references 9: all Russian.  
[176-6508]

## STRENGTH OF WELDED JOINTS IN VT23 ALLOY UPON REPEATED STATIC LOADING

Kiev AVTOMATICHESKAYA SVARKA in Russian No 7, Jul 83  
(manuscript received 25 Jan 83) pp 42-44

TOPOL'SKIY, V. F., engineer, Kiev, KISHKINA, S. I., doctor of technical sciences, STRONINA, L. A., engineer, KHOREV, A. I., doctor of technical sciences, MIKHALEV, Yu. D., LEONT'YEV, V. Ya., engineers, Moscow

[Abstract] Alloy VT23, 30 mm thick, was welded by two arcs using infusible tungsten electrodes in argon. Mechanical testing indicates that the SP14 and SP15 welding wires used in this study can provide a joint strength of 1000-1100 MPa. Short-term fatigue testing was performed with repeated pulsating load at 20 to 30 cycles per minute. The stress level of the test

was 50 to 64% of the short-term strength of the material. The optimal heat treatment for these joints is annealing at 750°C in combination with two-stage aging. SP15 wire yields the best joint characteristics under these conditions. Figures 1; references 5: all Russian.  
[176-6508]

UDC: 621.791.754'293.052:669.295:620.17

#### FRACTURE TOUGHNESS CHARACTERISTICS OF WELDED JOINTS IN VT6S AND AT6 TITANIUM ALLOYS

Kiev AVTOMATICHESKAYA SVARKA in Russian No 6, Jun 83  
(manuscript received 3 Aug 82; in final form 3 Nov 82) pp 43-45

YESINA, S. I., engineer, KUTEPOV, S. M., SKOROKHODOV, V. N., candidates of technical sciences, Scientific Research Institute of Chemical Machine Building

[Abstract] VT6S and AT6 high strength titanium alloys are used as corrosion resistant structural materials for the manufacture of high pressure vessels and other equipment. Increasing the strength of these alloys is accompanied by a decrease in their ductility. The problem of estimating the resistance of welded joints to brittle fracture is therefore an important one. The purpose of this work is to determine the critical stress intensity factor  $K_{Ic}$  for various sectors of the welded joint of hot rolled sheet AT6 and VT6S products 20 and 50 mm thick. When 2V welded wire is used in manual argon-arc welding, fracture toughness is equal to that of the base metal. AT6 rolled products are generally preferable to VT6S in terms of fracture toughness. Annealing in air at 820 to 830°C for one hour has practically no influence on crack resistance of welded joints in the two metals. References 10: all Russian.  
[152-6508]

## THREE-ARC WELDING OF STRAIGHT-SEAM LARGE DIAMETER PIPE WITH REDUCED HEAT INPUT

Kiev AVTOMATICHESKAYA SVARKA in Russian No 6, Jun 83  
(manuscript received 28 Jul 82; in final form 24 Feb 83) pp 50-52

MANDEL'BERG, S. L., doctor of technical sciences, SIDORENKO, B. G., LOPATA, V. Ye., engineers, BOGACHEK, Yu. L., candidate of technical sciences, KOBAL'EVSKIY, V. A., engineer, Institute of Electric Welding imeni Ye. O. Paton, Ukrainian Academy of Sciences, SERGEYEV, I. I., candidate of technical sciences, KALININ, S. A., engineer, Chelyabinsk Pipe Rolling Plant, KOTENZHI, Yu. V. and ZAVIDOV, S. V., engineers, Khartsyzsk Pipe Plant

[Abstract] In the manufacture of large diameter pipe multiple arc welding under flux is used. Attempts to assure failure-free operations of pipelines with increased throughput capacity, particularly in the far north, have required the use of special steels manufactured with controlled rolling. These steels are highly resistant to brittle fracture. The creation of new steels and successful improvement of technology and equipment for pipe manufacture have required development of multiple arc welding techniques with low heat input. It is desirable for this purpose to simultaneously reduce arc voltage and electrode span. The current and voltage across the arc are determined by the point of intersection of the volt-ampere characteristic with the power supply characteristic. Spans dropped from 50 or 60 to 25 or 30 mm in three-arc welding under laboratory conditions, while preserving the same productivity. The voltage across the arc dropped from 50-60 to 30-35 V, reducing the energy per unit length by 25 to 35%. Data on the energy per unit length achieved in welding of gas pipelines 120 and 1420 mm in diameter by the improved technology are presented in tabular form. Consumption of electric welding wire and flux decreased by 20 or 25%. Figures 4; references 5: all Russian. [152-6508]

UDC 621.791.85:669.14

## FEATURES OF LASER WELDING OF MEDIUM CARBON STEEL THROUGH A CADMIUM COATING

Moscow FIZIKA I KHIMIYA OBRABOTKI MATERIALOV in Russian No 4, Jul-Aug 83  
(manuscript received 13 Jan 82) pp 17-21

UGLOV, A. A. and OFER, V. I., Moscow

[Abstract] The effect of cadmium as an easily melted coating on formation of melting zones during laser welding of steel 35 was determined on a "Kvant-10" device with 4 ms impulse focussed on the material surface. Impulse energy was varied from 1 to 20 joules with a light filter. After welding, the metal structure was measured by etching in  $\text{HNO}_3$ , and microhardness

was measured within 5%. The thermal effect zone was greatly increased with energy of 5-10 joules regardless of coating thickness. A series of tests was also run on laser welding of rings with a set clearance. Results showed that the depth of the thermal effect zone remained the same as for welds with no clearance. Crater formation that occurred was attributed to the fact that cadmium vaporizes at a temperature half that of the melting temperature for steel 35. The cadmium served as an effective energy absorbent, bringing a reduced density to the required flow of laser energy. Figures 3; references 3; all Russian.  
[173-12131]

UDC 621.791.753.5

#### SUPPRESSING POROSITY IN WELD JOINTS OF 1420 ALUMINUM ALLOY

Moscow SVAROCHNOYE PROIZVODSTVO in Russian No 7, Jul 83 pp 36-38

ABRALOV, M. A., ABDURAKHMANOV, R. U. and KARTYSHOV, N. G., candidates of technical sciences and ABDURAKHIMOV, A. A., SAIDOV, R. M., POLEZHAYEV, M. A. and KULIKOV, F. R., engineers

[Abstract] In melting welds of 1420 aluminum alloy the greatest problem is the tendency to form pores, and many approaches have been used to eliminate it. The present study reports on a procedure that sought to minimize surface metal loss that results in processes involving mechanical scouring or chemical milling. A flux labelled TFA-8 was developed that contained fluorine compounds of calcium, barium, lithium and lanthanum, as well as lithium chloride and metallic nickel. The flux prevented reaction with the atmosphere that would produce hydrogen, created favorable conditions for "surfacing" and elimination of gas bubbles, lengthened the melt time of the weld seam, thus permitting gas bubbles to escape, and provided a microalloying effect that resulted in a denser seam metal structure. The resulting welded joints were found to have high corrosion resistance under conditions involving maritime mists and aqueous saline solutions in other applications. Figures 3; references 14; all Russian.  
[166-12131]

UDC 621.791.025:620.193

#### EFFECT OF WELDING METHOD ON CORROSION RESISTANCE OF WELDED COMPOSITIONS MADE OF 1201 ALLOY

Moscow SVAROCHNOYE PROIZVODSTVO in Russian No 7, Jul 83 pp 34-35

PASHINA, N. A., IVANOVA, L. Ye. and USTINOVA, G. S., engineers

[Abstract] The aluminum alloy 1201 in stressed and thermally-treated forms is promising for products that are subjected to cold and heat extremes. The

present article reports on argon-arc and electron-beam variants for welding joints, which were then subjected to artificial aging at 180°C after annealing. The resulting samples were measured for corrosion at seams, thermal effect zones and in the basic metal, in solutions containing varying amounts of NaCl, H<sub>2</sub>O<sub>2</sub>, HCl and K<sub>2</sub>CrO<sub>4</sub>. Results showed that the electron-beam welds provided better corrosion resistance as evidenced in part by their higher positive electrical potential. Figures 2; references 3: all Russian.  
[166-12131]

UDC 621.791.4:539.378.3

#### EFFECT OF ROLLING TEXTURE ON COMPOUND FORMATION IN DIFFUSION WELDING OF TITANIUM ALLOYS

Moscow SVAROCHNOYE PROIZVODSTVO in Russian No 7, Jul 83 pp 29-31

KARAKAZOV, E. S., doctor of technical sciences and TERNOVSKIY, A. P. and LAVROV, B. A., candidates of technical sciences, Moscow Evening Metallurgical Institute

[Abstract] Since structural elements affect the kinetics of compound formation in diffusion welding of titanium alloys, the present study was devoted to consideration of the axial orientation of structure on creep, physical contact and durability growth kinetics in VT6 alloy samples when welded with radiation heating and lever-controlled stress in a  $2.66 \cdot 10^{-3}$  Pa vacuum at temperatures of 900-1000°C. Results showed that the effect of structure on the deformation capacity of microprojections and on macrodeformation was the same. Microrelief warping at 900°C amounted to 63, 33 and 48% with varying orientations of welded samples. Thus crystalline orientation of rolled alloys must be considered in determining welding procedures and applications of the VT6 products. Figures 5; references 5: 4 Russian, 1 Western.  
[166-12131]

UDC: 621.791.011:669.245.018.44:539.4

#### WELDABILITY OF AGED HEAT RESISTANT NICKEL ALLOYS

Kiev AVTOMATICHESKAYA SVARKA in Russian No 7, Jul 83  
(manuscript received 15 Sep 82; in final version 1 Dec 82) pp 12-16

SOROKIN, L. I., candidate of technical sciences, Moscow

[Abstract] It is suggested that the decrease in strength of welded joints in dispersion hardened alloys after aging is caused by a rise in the rate of increase of tensile deformations in the seam due to an increase in heat resistance of the alloys in the aged state, as well as the degree of strength loss in welded joints made after aging as a function of the composition of the

metal, the welding wire and the welding method. Studies were performed on nickel alloys with high iron content. Mechanical properties were determined in specimens cut across seams made in alloy samples 2, 12, 15 and 20 mm thick by argon-arc and electron beam welding. Argon arc welding was performed manually with a tungsten electrode and various welding wires. Electron beam welding was performed on an ELU-4 welding machine with a U-530A welding gun at 0.008 m/s. It was found that the alloys EP693, EP914 and EP718 when aged have 1/2 to 2/3 the resistance to hot crack formation that they have in the hardened state. Strength of EP437 alloy is the same in the hardened and aged states. Both methods of welding of all four alloys in the aged state using welding wire consisting of the base metal plus EP533 alloy produce joints with less heat resistance than that of joints aged after welding. When EP367 welding wire is used this is also true at 20°C for metal 2 mm thick. At greater thicknesses or higher temperature the strength of the joints is lower, approximating that of metal surfaced with EP533 and EP367 wire. Figures 5; references 8: 7 Russian, 1 Western.  
[176-6508]

UDC: 621.791.927.55"669.35'6:629.12-2

#### PLASMA SURFACING OF BRONZE IN MARINE MACHINE BUILDING

Kiev AVTOMATICHESKAYA SVARKA in Russian No 7, Jul 83  
(manuscript received 9 Dec 82) pp 49-51

CHKALOV, L. A., engineer, FRIMIN, I. I., doctor of technical sciences, GLADKIY, P. V., candidate of technical sciences, Kiev, KUZNETSOV, V. A., ZASEDATELEV, G. F. and SHMELEV, Yu. V., engineers, Gor'kiy

[Abstract] Plasma surfacing of copper alloys with reverse polarity current is superior to manual surfacing. The process is used at the Krasnoye Sormovo plant imeni A. A. Zhdanov for mechanized surfacing of type Br AZhNMTs 8.5-4-5-1.5 bronze, using bronze powder of the same type. The use of reverse polarity breaks up the oxide film on the surface of the base metal and the welding bath. This achieves good wetting of the steel surface with the bronze, facilitating good surfacing quality. It has been found that there is a broad range of values of current, powder feed rate and surfacing speed for which process parameters remain practically unchanged. The new process has increased the productivity of labor by a factor of 3 to 8, halving the consumption of surfacing materials and significantly improving the quality of the surfaced metal. Figures 5; references 4: all Russian.  
[176-6508]

NEW METALLURGICAL PROCESSES BASED ON HIGH-SPEED CRYSTALLIZATION AND DIFFUSION OF METALS

Moscow IZVESTIYA AKADEMII NAUK SSSR: METALLY in Russian No 6, Nov-Dec 1982 (manuscript received 3 Jul 82) pp 11-20

[Article by A.F. Belov, Moscow]

[Text] In the second half of the 60's domestic and foreign investigators began to develop fundamentally new methods of influencing a metal, whose main difference consisted in a rate of crystallization of melts higher by several orders of magnitude. These conditions made it possible to eliminate a number of metallurgical defects and imperfections and at the same time to produce a metal with a considerably improved combination of properties.

The required high rates of crystallization could be made possible with very rapid removal of heat from the molten metal, and this proved to be possible only if its volume is quite small--as demonstrated by calculations and then by experiments--in the form of a minute drop which solidifies into a pellet measuring a few dozen to a few hundred microns in diameter. Finished parts are produced from these pellets by compacting: A great number of pellets, as the result of the occurrence of diffusion processes under high pressures and temperatures under conditions of hot isostatic compaction, are united into a monolith having 100-percent density.

The use of high-speed crystallization processes for metals (VKM processes) and diffusion processes, including under hot isostatic compaction (GIP), has opened up the possibility of creating new technological processes for producing high-quality metallic materials from nickel, titanium and aluminum alloys with a homogeneous structure and new properties not achieved previously, including enhanced strength and failure toughness and short-time and long-time fatigue, higher high-temperature strength and corrosion resistance and a lower specific quantity of metal and labor intensiveness in fabrication of finished parts.

Some aspects of the development and application of new metallurgical processes based on VKM and diffusion processes are discussed below in concise form.

#### Pellet Metallurgy of Heat-Resistant Nickel and Titanium Alloys

The new metallurgical process turned out to be advantageous to use primarily for fabricating parts from heat-resistant nickel alloys. As of the moment studies began,

the high-temperature strength level of nickel alloys for turbine disks both here at home and abroad was not higher than  $\sigma_{100}^{750} = 42 \text{ kg/mm}^2$ .

The flowchart for fabricating products based on methods of pellet metallurgy can be implemented in several variants, depending on their nature and purpose [1]. The most economical variant contains a minimum number of operations: production of pellets, degassing and sealing capsules, and compacting and heat treating of products. A study of pellets of alloys ZhS6U and EP741 for two methods of sputtering the melt by means of an inert gas and the rotating electrode method has demonstrated that the range of particle dimensions of the dendritic structure and carbide phases is determined basically by the rate of cooling of the drops during crystallization [2], which varies over a wide range—from  $10^2$  to  $5 \cdot 10^4$  deg/s. The dimensions of the pellets and the type of cooling medium exert the greatest influence on the cooling rate.

The conditions for the production of pellets determine the distinctive features of the structure of pellets, their shape, and level saturation with oxygen gas. As demonstrated in practice, large particles of carbides from a rotating electrode can change into pellets in sputtering of ingots of large sizes. Considerable dendritic liquation is observed within pellets [2]. In nickel alloys, titanium, niobium, chromium and aluminum are placed in interaxial sections of dendrites, and cobalt and tungsten on the axes.

In production-process heating, practically total equalization of intercrystallite inhomogeneity is achieved in pellets, unlike in ingots. Elements are distributed sufficiently uniformly within the limits of each pellet on scales comparable with the size of its radius. The chemical composition of pellets within the range of a sputtering batch practically does not depend on their size.

It has been established that the decisive mechanism responsible for formation of contact between pellets in free sintering is diffusion mass transfer. The influence of other sintering mechanisms (motion of dislocations, boundary slip) is not great; therefore, the size of pores is reduced at a quite insignificant rate and one which diminishes with time. Plastic deformation of sintered billets, which causes the appearance of additional grain boundaries, accelerates the process of diffusion dissolution of pores and at the same time results in rapid disappearance of porosity.

An optimal method of producing a compact material from pellets is the GIP method, while carrying out the process according to two process flowcharts—heating pellets in degassed capsules followed by compaction under isostatic conditions, and compaction with a simultaneous increase in temperature and pressure in a gasostat [3]. Mechanical properties have a tendency to improve with a rise in the compacting temperature from 1100 to 1200 °C and higher. Mechanical properties are more uniform in products made of pellets as compared with the cast and formed state regardless of the direction in which specimens are notched (lengthwise or depthwise), i.e., the material is characterized by total isotropy.

Studies which have been conducted have demonstrated that the compositions of alloys designed for producing products by the pellet metallurgy method must be

chosen by taking into account the specifics of the behavior of carbides--the tendency to separate secondary carbides from the supersaturated solid solution. Intelligent alloying with carbon and carbide-forming elements, which provides for a reduction in the concentration of carbon with a simultaneous increase in the content of alloying elements forming stable carbides of the MeC type, in combination with heat treating, which gives rise to the absence of a network of carbides along grain and pellet boundaries and a reduction in the dimensions of particles of the  $\gamma'$  phase, open up possibilities for further improving the mechanical properties of nickel alloys by the additional introduction of principal alloying elements (aluminum, titanium, niobium, etc.) responsible for formation of a hardening  $\gamma'$  phase. In keeping with these alloying principles, the alloy EP741N has been created, which as compared with alloy EP741 has a higher level of high-temperature strength in the compacted state ( $\sigma_{1000}^{750} \geq 700$  MPa (table 1)) with the absence of sensitivity to stress concentrators.

Table 1. Guaranteed Mechanical Properties of Heat-Resistant Alloys Produced by Various Processes

<u>Alloy and method of production</u>	<u>Properties at 20 °C</u>				<u>Longterm strength</u>	
	$\sigma_{0.2}$ , MPa	$\sigma_0$ , MPa	$\delta$ , %	$\psi$ , %	$\sigma_{1000}^{650}$ , MPa	$\sigma_{1000}^{760}$ , MPa
EI698, open melting + vacuum remelting + deformation	1150	720	14	16	740	400-420
EP742, double vacuum melting + deformation	1200	750	14	14	810	520
EP741, pellet metallurgy	1250	800	13	15	900	600
EP741N, ditto	1300	850	13	15	1000	700

Effective for new alloy EP741N is the employment of shortened holding (10 min instead of 4 h) and accelerated cooling (300 instead of 30 deg/min) in hardening for the purpose of preventing separation of carbides along grain and pellet boundaries. The use of each of these effects separately does not produce this result. The mechanical properties of products with this type of heat treating are characterized by maximum-achieved indicators for strength properties at 20 °C and long-term strength at elevated temperatures (table 1).

Based on the studies conducted, effective technological processes have been developed for producing products from alloys of the EP741 type by the hot isostatic compaction method, making it possible to produce a highly dispersed homogeneous structure and high and uniform mechanical properties.

Pellet metallurgy makes it possible to produce parts with a nonuniform chemical composition and properties over their cross section--e.g., the center part can have

high strength properties at 20 °C and the periphery high heat resistance strength. In principle it is possible to produce by pellet metallurgy methods parts with a very complex configuration, since the pellets in filling the mold have the same mobility as a liquid. For example, it is possible to produce a disk as a single whole with blades, including with different mechanical properties for the disk's hub and blades.

Pellet metallurgy has proved to be even more effective and promising for titanium than for nickel alloys because of the ability of titanium to dissolve oxygen, which facilitates the process of consolidation of individual pellets during treatment in a gasostat. However, the production of parts from pellets of titanium alloys has, as demonstrated in practice, its own difficulties as the consequence of the high activity of titanium.

The possibility has been revealed of producing rolled products from titanium alloys with a large cross section with an ideally uniform structure, which it is not possible to produce by existing methods. For the purpose of making a slab of the required shape, titanium alloy pellets are poured into a capsule, degassed, sealed and treated in a gasostat. Slabs rolled from this stock surpass in quality slabs produced by traditional methods. It has proven even more effective to fabricate from titanium pellets stock with a round cross section about 120 mm in diameter for the purpose of extrusion and section rolling instead of traditional casting of ingots 800 mm in diameter and subsequent intermediate heating and repeated forging to the required dimensions. When stock produced by pellet metallurgy methods is used, the direct possibility is opened up of utilizing the effect of superductility, which makes it possible to make the technology of producing rolled titanium products considerably more efficient.

#### Aluminum Alloys Crystallized at Cooling Rates of $10^3$ to $10^4$ deg/s

As a result of investigation of mechanisms of modification of the structure and properties of ingots as a function of the crystallization rate, the fundamental principles have been developed for alloying of aluminum alloys produced under conditions of rapid crystallization [4].

Based on the alloying principles developed, a new group of aluminum alloys has been created whose existence is possible at all only because of high cooling rates in crystallization. These are heat-resistant alloys alloyed with transition metals (Mn, Cr, Zr, etc.), high-strength alloys of the Al-Zn-Mg-Cu system alloyed in addition with transition metals in an amount of 1.2 to 1.5 percent by weight, and alloys with special physical properties alloyed with transition metals (Fe-Co-Ni) practically insoluble under conditions of equilibrium, with rare earth and some other metals (Si, Pb, Sn).

For example, high-strength alloys (table 2) display longterm strength after 100 h at a temperature of 350 °C equal to 60 MPa, whereas for the standard heat-resistant aluminum alloys D20 and AK4-1 it equals 30 to 35 MPa. Heat-resistant pelletized alloys are typical age-hardening alloys in which the hardening process takes place in the casting of pellets and the ageing process during production-process heating and pressure treating. The size of the range of particle dimensions of particles

of intermetallide phases will determine the strength properties of the prepared semifinished items, and the tendency of intermetallide phases to coagulate, the longterm strength under elevated temperatures. The high adaptability to streamlined manufacture of pelletized aluminum alloys makes it possible to make from them both large-dimension forgings and thin-walled products--capillary tubes measuring 2 X 0,2 mm, foil, etc.

Pelletized materials have passed tests in many industries of the national economy and everywhere have been displaying higher utilization, technological and corrosion-resistance characteristics. For example, the high-strength pelletized alloy 01419"U" has been recommended successfully for use instead of stainless steel and titanium for prolonged working at temperatures of 300 to 400 °C. In addition to this, the heat-resistant alloy is brazed well in salt baths. The strength of brazed joints is two times higher than that of a joint of the AMts material used at the present time.

The pelletizing method makes it possible to create also alloys which possess a number of special properties. For example, alloys with high electrical conductivity for prolonged working at temperatures of 250 to 300 °C; x-ray contrast materials for checking the quality of spot-welded and seam-welded aluminum alloys; highly corrosion-resistant alloys for desalination of sea water; and alloys with low and high neutron capture.

#### Aluminum Alloys Crystallized at Cooling Rates Greater Than or Equal to $10^6$ deg/s

Increasing the cooling rate during crystallization to superhigh values of about  $10^6$  deg/s results in formation of materials with unique properties. With this, not only are the above-discussed rules for the influence of the crystallization rate on the structure evidenced more clearly, but new structural effects are also revealed. Here it is possible to mention the following features of the change in structure and phase composition.

1. Comminution of branches of dendrites and second-phase particles, resulting from increasing noncorrespondence of rates of heat release and mass transfer. Here the degree of comminution of second-phase particles increases to such an extent that in pellets these particles can be an effective hardener.
2. Expansion of the region of hypoeutectic crystallization becomes especially noticeable, as well as an increase in the concentration of the second component in the solid solution with which primary crystals of intermetallic phases are formed in eutectic and peritectic systems. At the same time the actual distribution factor shifts to one, and the degree of intracrystallite liquation is accordingly reduced.
3. A subdendrite structure is formed for the cast metal. The cooling rates achievable under industrial conditions for aluminum alloys are insufficient for the purpose of producing a metallic glass, but the structure of the pellet is changed considerably by the additional increase in the cooling rate on account of the supercooling effect.

Table 2. Composition and Properties of Pelletized Aluminum Alloys

Grade of alloy	System	Purpose	Semifinished items	Mechanical properties			Note
				$\sigma_y$ , MPa	$\sigma_{0.2}$ , MPa	$\delta$ , %	
<u>Alloys Mastered in Industrial Production</u>							
01996	Al-Zn-Mg-Cu with add. of Cr and Zr	High-strength	Sections	>750	>700	>5	For riveted structures
01995	Al-Zn-Mg with add. of Cr and Zr	High-strength	Sheets	>600	>500	>6	For welded structures
01419U	Al-Mn-Cr-Zr	Heat-resistant	Sheets	360	300	10	For welded structures
01209	Al-Cu-Mn with add. of Cr and Zr	High-strength	Sections	500	400	10	For cryogenic temperatures
01379	Al-Si with add. of Mg; Cu	With low coefficient of linear expansion	Forgings	400	350	4	For pistons
01417	Al - rare earth metal	Conductor	Wire	260	200	≥12	For working at 250 °C
01415	Al - rare earth metal with add. of Cr	X-ray contrast	Foil	280	220	>5	For controlling quality of welded joints
<u>Experimental Alloys</u>							
01439	Al - rare earth metal with add. of Cr, Zr	X-ray shielding	Sheets	360	320	8	Structural

[Continued on following page]

Experi- mental	Al-Ti with add. of Zr, V	Highly corrosion- resistant	Pipes	280	220	16	-	-	For desali- nation plants
Experi- mental	Al-Nb-Zr	With low neutron capture coeffi- cient	Pipes	260	200	12	-	-	For nuclear reactors

All this makes it possible to produce a previously unattainable level of properties in aluminum alloys cast in the form of pellets with superhigh cooling rates. As the results of tests have shown (table 3) an aluminum alloy of the 01996 type has strength two times greater than the strength of ornamental steel.

Table 3. Mechanical Properties of Pelletized Alloys Produced Under Superfast Crystallization ( $10^6$  deg/s)

<u>Alloy</u>	<u><math>\sigma_v</math>, MPa</u>	<u><math>\sigma_{0.2}</math>, MPa</u>	<u><math>\delta</math>, %</u>
01996	850	750	4
01419U	450	420	10

Superhigh crystallization rates make it possible under industrial conditions to achieve in aluminum alloys considerably greater supersaturation with refractory metals than takes place with a cooling rate of  $10^3$  to  $10^4$  deg/s. For example, with a cooling rate of  $10^3$  to  $10^4$  deg/s, up to 5 percent by weight Mn or up to 3 percent by weight (Cr + Zr) are introduced into the solid solution, whereas with a cooling rate of  $10^6$  deg/s supersaturation constitutes 11 percent by weight Mn and up to 7 percent by weight (Cr + Zr).

An increase in the content of refractory metals provides an additional hardening effect in pelletized alloys and an improvement in properties in prepared semi-finished items (table 3). For example, whereas the microhardness of pellets of an Al + 1.5% Cr + 1.5% Zr alloy in the original state equals 55 kg/mm<sup>2</sup>, the microhardness of pellets of an Al + 2.5% Cr + 2.5% Zr alloy is 92 kg/mm<sup>2</sup> and the microhardness of an Al + 3.5% Cr + 3.5% Zr alloy is 112 kg/mm<sup>2</sup>.

The microhardness increases in heating, as the result of decomposition of the anomalously supersaturated solid solution. The microhardness maximum in the Al + 1.5% Cr + 1.5% Zr alloy is 115 kg/mm<sup>2</sup>, and 155 kg/mm<sup>2</sup> in the Al + 2.5% Cr + 2.5% Zr alloy. The higher hardening effect in the decomposition of an anomalously supersaturated solid solution of refractory metals in aluminum also provides higher strength characteristics (cf. alloys 01996 and 01419U in tables 2 and 3).

#### Hot Isostatic Compaction as a Means of Healing Defects in Metals

With the appearance of gasostats used in pellet metallurgy for nickel and titanium alloys, the real possibility arose of eliminating defects in cast, deformed and welded metallic semifinished items. For substantial improvement of properties, we conducted an extensive set of scientific research studies on investigating conditions for GIP [hot isostatic compaction] castings. As of the present time a technology has been developed for hot isostatic compaction of cast parts made of heat-resistant nickel alloys and steel, which includes applying a protective enamel to the surface of the castings, GIP, removal of the enamel, and heat-and-vacuum treating.

Two basic processes take part schematically in the mechanism of the compaction of castings in GIP: creep and diffusion. The compaction sequence is as follows:

1) mechanical closing of pores and micropores on account of creep; 2) formation of metallic bonds by diffusion welding; and 3) diffusion annealing.

An ideal case is the sealing of shrinkage pores, since the surfaces to be connected are clean. Inside these pores is a vacuum and only low-melting phases can be on the surface.

The comparative mechanical properties of cast parts and parts after GIP are presented in table 4. It follows from these data that as the result of GIP the strength is increased to 60 MPa, ductility is increased 1.5-fold and longterm strength more than 1.5- to 2-fold. Treatment with GIP of castings made of titanium alloys produces an even more considerable effect.

Table 4. Properties of Nickel Alloy Heat-Treated in Cast State (I) and After Hot Isostatic Compaction (II)

<u>State of metal</u>	<u><math>\sigma_v</math>, MPa</u>	<u><math>\delta</math>, %</u>	<u><math>\psi</math>, %</u>	<u><math>\tau_{lc}</math>, h at 975 °C under load of 200 MPa</u>	<u>Results of inspection after testing</u>
I	<u>843-1000</u> 922	<u>1.6-12.0</u> 6.8	<u>1.0-16.0</u> 8.5	20-70	Reject defects found in 85 percent of parts
II	<u>930-1045</u> 988	<u>6.8-11.6</u> 9.2	<u>12.3-19.6</u> 15.4	66-103	Defects not found in a single part

We know that slabs and panels made of aluminum alloys have quite considerable anisotropy, expressed primarily in poor properties along the direction of the depth of the cross section, including in terms of ultimate strength and especially in terms of elongation and reduction.

After treatment in a gasostat, the level of depthwise ductility of slabs and panels is improved considerably and a considerable increase is observed in the failure toughness coefficient,  $K_{Ic}$ : The value of  $K_{Ic}$  in high-strength aluminum alloys in the original state, i.e., not subjected to gasostat treatment, after heat treating is 72.0 kg/mm<sup>3/2</sup>, and after gasostating and heat treatment, 101.9 kg/mm<sup>3/2</sup>. But what is most important, the defects revealable by ultrasonic testing completely disappear (table 5). The value of GIP treatment of large-dimension slabs and panels for the purpose of extending their service life is difficult to overestimate.

Table 5. Elimination of Defects Revealable by Ultrasonic Testing, in Gasostat Treatment of Panels and Slabs

<u>Alloy</u>	<u>Semifinished items</u>	<u>Before GIP</u>		<u>After GIP</u>	
		<u>Testing reflector, mm</u>	<u>Total amount of defects</u>	<u>Testing reflector, mm</u>	<u>Total amount of defects</u>
D16chT	Panel	1.2-3.2	68	1.2 and more	None
V95pchT2	Slab	1.2-1.6	240	1.2 and more	None

### Hot Isostatic Compaction for Healing Welding Defects

Tests of welds of austenitic steel containing 18 to 20 percent Cr, 8 to 10 percent Ni, 0.08 percent C and 2.0 percent Si treated by GIP showed improvement of ductility in welds: 26 percent in slabs and 36 percent in pipes. And in welds into which defects were intentionally introduced: 173 percent in slabs and 140 percent in pipes at room temperature, and up to 233 percent at a temperature of 315 °C. Impact testing showed a 160-percent increase in impact energy, whereby failure toughness increases 67 percent.

### Hot Isostatic Compaction for Restoring Life to Worn Parts

The properties of castings and other parts of aircraft engines change gradually as the result of the influence of high temperatures and cyclic loads, and with time defects appear at grain boundaries which are like shrinkage defects and can be centers for the origin of cracks. Since these defects are internal they can be healed by hot isostatic compaction, whereby the mechanical properties and fatigue strength of parts which had been in use in the engine are restored to the level of properties at least equal to the properties of new parts.

All large stressed parts can be subjected to restoration by the GIP method in aircraft engine building; these include shafts, disks and also blades. Data are available on utilization of this process in the nuclear power industry.

### Diffusion Welding

Diffusion welding is one promising technological process making it possible to produce products of complex shape from like and unlike materials with high quality of the joint. The essence of the method consists in the fact that the part to be welded, assembled from simple elements, is heated under vacuum or in an inert medium to temperatures below the melting point, after which pressure is imparted to the surfaces to be joined (fig 1). At the initial stage of formation of the joint, the formation of physical contact takes place on account of the removal of surface microprotuberances and growth of the contact surface over time as the result of the action of the creep and sintering mechanisms. As the recrystallization process develops, the interface migrates, joint grains form in the welding zone and healing of internal microvoids takes place right up to their disappearance.

Various methods of joining are used, depending on the nature of the materials to be welded and the type of constructions. In titanium alloys the high rate of dissolution of surface oxides when they are heated under vacuum to welding temperatures makes it possible to produce fully adequate joints without the use of intermediate layers. Joints of high quality can be produced also in direct diffusion welding of heat-resistant nickel alloys, including for unlike combinations of them. Typical structures of welded joints of like and unlike titanium and nickel alloys are shown in fig 2 as an example [photograph not reproduced]. The fabrication of precision parts and products made of unlike compositions in the welding of which the formation of brittle intermetallide phases is possible requires the use of thin interlayers, as a rule, in foil form.

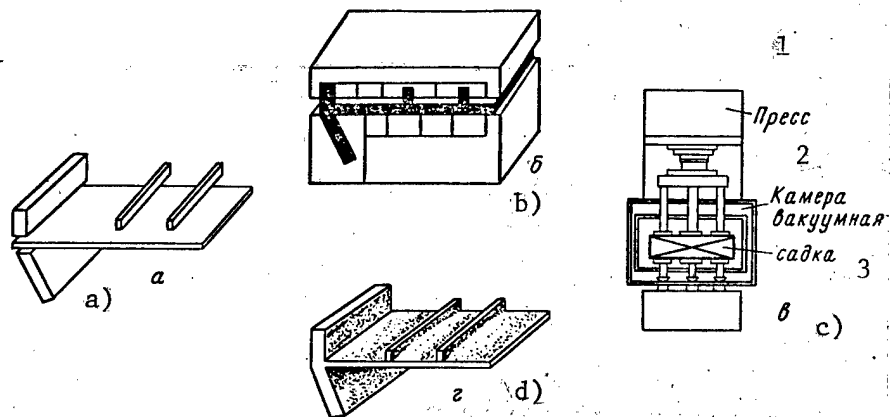

Figure 1. Diagram of Process of Diffusion Welding of Stock of Complex Shape: a--elements to be welded; b--assembly; c--welding; d--welded stock

Key:

- |                   |           |
|-------------------|-----------|
| 1. Press          | 3. Charge |
| 2. Vacuum chamber |           |

The principles of selection of the material for interlayers and of their structural state must be considered sufficiently developed at the present time. However, it is possible to point out the following criteria which are of first-level importance in selection of interlayers: closeness of the coefficients of thermal expansion and melting points of the interlayer and metals to be welded, and the existence of a wide region of intersolubility. For precision diffusion welding, where even slight plastic deformation is impermissible, high joint quality is made possible by the use of "soft" interlayers of the same composition (having an ultrafine-grain structure) or of "disappearing" interlayers (having a lower melting point than the metals to be welded). The data of an x-ray spectral microanalysis illustrating the achievement of a homogeneous joint after welding and subsequent annealing of heat-resistant nickel alloy ZhS6u utilizing an Ni-B disappearing interlayer are shown in fig 3.

The process of diffusion welding makes it possible to produce a combination of mechanical properties which is practically unachievable in fusion welding (table 6). As is obvious from table 6, welded joints of titanium and nickel alloys have properties equivalent to those of the base metal with respect to an entire series of characteristics, with some reduction of impact strength and close values of failure toughness.

Among the other technical advantages of the process over fusion welding must be listed provision of a homogeneous structure in the zone of the joint, absence of residual stresses, the possibility of welding unlike composites, and the production of a great number of welds in a single cycle. An important factor also is the considerable reduction in the power of the press equipment required as compared

with the traditional forging technology. For example, for the purpose of fabricating finned stock made of titanium measuring 0.5 X 1 m in the plane, welding units with a force of 250 tons are sufficient; whereas a press with a capacity of 30,000 tons would be required for producing them by stamping.

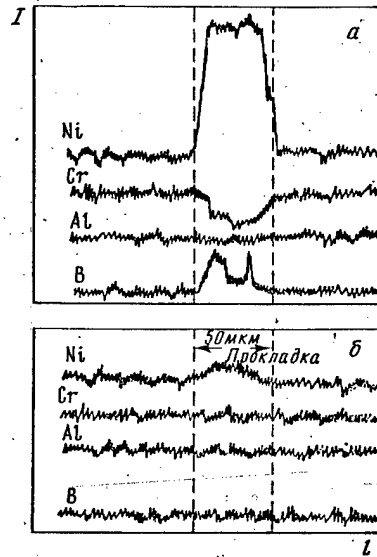

Figure 3. Distribution of Some Alloying Elements in ZhS6u Base Alloy and Ni-B Interlayer: a--directly after diffusion welding; b--after annealing at 1200 °C at 24 h

Key:

1. Interlayer

Table 6. Mechanical Properties of Welded Joints of Titanium and Nickel Alloys as Compared with Base Metal (I--welded joint; II--ratio to indicator for base metal)

Alloy	Indicator	Mechanical properties	
		I	II
VT6	$\sigma$ , MPa	910.0	1.0
	$\delta^V$ , %	14.0	1.0
	$\psi$ , %	30.0	1.0
	$K_{Ic}$ , MPa $\sqrt{m}$	840.0	0.92
	$\sigma_{100}^{450}$ , MPa	450	1.0
	$a_n$ , J/cm <sup>2</sup>	44	0.8
	$N^n$ cycles with $\sigma = 500$ MPa , $\psi = 40$ Hz , $r = 0.1$	55,700-	1.0
		145,100	

[Continued on following page]

ZhS6u	$\sigma$ , MPa	980	1.0
	$\delta^v$ , %	5.0	1.0
	$a_n$ , J/cm <sup>2</sup>	15.0	0.97
	$\tau_n$ , h, with	36	0.9
	$\sigma = 230$ MPa at 975 °C		

In evaluating the potential capabilities of the process it is necessary to indicate the two most promising areas of its application: 1) improving the economic efficiency of the production of large-dimension stock whose fabrication by traditional methods involves a great specific quantity of metal and labor intensiveness; 2) the production of a new class of materials and products which satisfy modern design requirements in terms of their properties and geometry.

The economic efficiency of the diffusion welding technology is graphically illustrated by its use for fabricating large-dimension structures made of titanium alloys in place of their production by machining from slabs or rough forgings. In this case a 2- to 4-fold increase in the metal utilization factor and a 3- to 10-fold reduction in labor intensiveness of machining are possible with a considerable saving of expensive metal.

In spite of the considerable technical and economic efficiency of the diffusion welding process, its introduction in the production of semifinished items and products requires the solution of a combination of complicated problems involving the creation of special-purpose equipment and the carrying out of extensive research for development of the technology and finding nondestructive methods of testing welded parts.

#### Bibliography

1. Belov, A.F., Anoshkin, N.F. and Fatkullin, O.Kh. "Formation of Structure and Properties of Nickel Alloys in Process of Production of Products from Pellets," STAL', No 11, 1981, p 78.
2. Fatkullin, O.Kh., Zvereva, Ye.A., Rabinovich, M.Kh. et al. "Dendritic Liquefaction in Powders of Heat-Resistant Alloys," TEKHOLOGIYA LEGKIKH SPLAVOV, No 5, 1976, p 47.
3. Belov, A.F. and Fatkullin, O.Kh. In "Konstruktsionnyye i zharoprochnyye materialy dlya novoy tekhniki" [Construction and Heat-Resistant Materials for New Equipment], Moscow, Nauka, 1978, p 17.
4. Dobatkin, V.I. and Yelagin, V.I. "Granuliruyemyye alyuminiyevyye splavy" [Pelletized Aluminum Alloys], Moscow, Metallurgiya, 1981, p 175.

COPYRIGHT: Izdatel'stvo "Nauka", "Izvestiya AN SSSR, Metally", 1982

8831

CSO: 8144/1758

## INHERITANCE OF TWIN BOUNDARIES AS A SHAPE MEMORY MECHANISM

Sverdlovsk FIZIKA METALLOV I METALLOVEDENIYE in Russian Vol 55, No 6, Jun 83  
(manuscript received 27 Jul 82) pp 1045-1050

BRAUNIN, G. E., VOLKOV, A. Ye. and KIKHACHEV, V. A., Leningrad State  
Universtiy imeni A. A. Zhdanov

[Abstract] It is demonstrated that shape memory and related phenomena can be explained by the crystallographic features of the martensite transformation in martensite with division boundaries. Deformations, stresses and work are calculated on the basis of the suggested crystallogometric mechanism. The authors propose that a crystal is deformed either due to the plasticity of direct transformation or by twinning of martensite, or by intramartensite reactions from martensite to another martensite. Macroscopic distortion causing austenite to martensite transformation or twinning is fully determined by the distortions of each of the transformations in the lattice and of the mechanism of plastic accommodation at the phase division boundary or twin boundary. It is considered that the reverse deformation upon heating of the material from martensite to austenite state involves distortions which are the reverse with respect to these initial distortions, but not necessarily preserving the same mechanism of accommodation. This idea serves as the basis for calculation of transformation plasticity deformation, martensite deformation and shape memory, including incomplete shape recovery. To explain why the reverse restructuring of the lattice occurs precisely back to the original shape the role of boundaries between twins or intramartensite boundaries in phenomena of the reverse martensite transformation are used. The article shows that when distortion upon heating is equal to reverse distortion of direct reactions the austenite formed does not contain division boundaries. If the reverse restructuring of the lattice is not precise, the twin boundaries are inherited by the austenite and act as sources of stress, greatly increasing crystalline energy. References 6; all Russian.  
[159-6508]

STABILIZATION OF OXIDE FILM GROWTH INSTABILITY ON METAL SURFACES HEATED BY POWERFUL INFRARED RADIATION

Moscow POVERKHNOST': FIZIKA, KHIMIYA, MEKHANIKA in Russian No 10, Oct 82 (manuscript received 1 Apr 82) pp 117-120

BUZYKIN, O. G., BURMISTROV, A. V., VOLOD'KINA, V. L., GOR'BERG, S. M., MATYUSHIN, G. A. and TRIBEL'SKIY, M. I.

[Abstract] It is demonstrated that instability in the growth of an oxide film on the surface of a metal can be stabilized by special time modulation of the intensity of powerful infrared radiation oxidizing the metal by the interaction of the metal with the radiation. A figure is presented illustrating the film thickness obtained by modulating laser radiation so that the surface temperature of the target remained below 1000°K during unstable stages of film growth. Film growth time is little influenced by the modulation, but film surface flatness is greatly improved. Figures 2; references 8; all Russian.

[163-6508]

UDC: 621.375.826:669.14.018.25

LASER ALLOYING OF U10 STEEL WITH CHROMIUM

Moscow POVERKHNOST': FIZIKA, KHIMIYA, MEKHANIKA in Russian No 10, Oct 82 (manuscript received 29 Dec 81) pp 134-139

ANDRIYAKHIN, V. M., YEDNERAL, N. V., MAZORRA, Kh. A. and SKAKOV, Yu. A., Moscow Institute of Steels and Alloys

[Abstract] The purpose of this work was to study the structure and phase state of the surface layer of U10 steel alloyed with chromium by the use of direct structural analysis methods (x-ray diffractometry and transmission electron microscopy) in order to determine the possibility of controlling the process. A layer 100 to 300  $\mu\text{m}$  thick consisting of a 50% mixture of chromium powder with a binder substance which burns off at a temperature of about 400°C (oxymethylcellulose) was applied to specimens. The surface was irradiated by a continuous CO<sub>2</sub> laser with power density 2 to  $7 \cdot 10^4$  W/cm<sup>2</sup>, producing a uniformly melted surface layer up to 1 mm thick with practically no evaporation, slight surface distortion and no defects through the depth of the layer itself. Focal spot diameter was 3 mm, rate of movement 0.5 to 1 m per minute. There was practically no redistribution of chromium among structural components as a result of the very high cooling rate. The process was found to be controllable within a certain range of change of laser parameters. Chromium was distributed uniformly throughout the 1 mm layer thickness, primarily by mixing of the liquid. The first phase to crystallize after laser action was always austenite. Figures 4; references 9: 7 Russian, 2 Western.

[163-6508]

## EFFECT OF DEFORMATION RATE ON DEFORMATION REACTION OF COMPONENTS OF A LAMINATE

Moscow FIZIKA I KHIMIYA OBRABOTKI MATERIALOV in Russian No 4, Jul-Aug 83  
(manuscript received 2 Mar 82) pp 120-123

MUKHIN, V. N., KOTOV, N. V. and CHAP, N. F., Volgograd

[Abstract] Stretching of laminated metallic materials with strong bonds in broad temperature and time intervals results in durability readings that surpass theoretical expectations, as well as accelerated deformation of the reinforced layer in the resilient zone. The present study considers the effect of deformation rate on the deformation reaction for a laminate composed of brass L62+niobium alloy VN2AE+brass L62 at 860°K in a vacuum, with various matrix thicknesses. Both positive and negative effects of deformation reaction were observed, with temperature and deformation rate as the determinants. The possibility that the durability parameter will invert during deformation makes it impossible to determine an optimum composition for laminated metal materials. Figures 2; references 14: all Russian.  
[173-12131]

UDC 669.3:539.378:539.219.3

## DIFFUSION OF COPPER IN EXPLOSIVELY DEFORMED METALS

Sverdlovsk FIZIKA METALLOV I METALLOVEDENIYE in Russian Vol 56, No 1, Jul 83  
(manuscript received 2 Nov 82) pp 206-208

BEKRENEV, A. N., Kuybyshev Polytechnical Institute imeni V. V. Kuybyshev

[Abstract] Study of the effect of preliminary plastic deformation has shown that so-called quasi-static methods are of little use in forming diffusion layers. The present study considers diffusion mobility of copper atoms in nickel, titanium and the VT9 titanium alloy after explosive deformation. All samples were carefully polished before being subjected to shock waves from various explosives. X-ray defraction curves were then drawn. Subsequent calculation showed first rising, then declining coefficients of mutual diffusion in nickel and titanium samples as pressure increased. Diffusion mobility decreased with pressure growth up to 50 GPa. Decreased diffusion speed was related to dislocational complexes that served as "snares" for diffusing atoms. Figures 3; references 6: 5 Russian, 1 Western.  
[174-12131]

CARBON DIFFUSION IN AN AMORPHOUS ALLOY:  $\text{Co}_{70}\text{Fe}_5\text{Si}_{15}\text{B}_{10}$ 

Sverdlovsk FIZIKA METALLOV I METALLOVEDENIYE in Russian Vol 56, No 1, Jul 83  
(manuscript received 23 Jun 82) pp 200-201

URYTU, S. G. and GRUZIN, P. L., Institute of Metal Studies and Metal Physics, Central Scientific Research Institute for Ferrous Metallurgy imeni I. P. Bardin

[Abstract] The present study seeks to explain the role of various components in amorphous alloys using a radiosotope spectrometric method to measure the diffusion of carbon in the alloy  $\text{Co}_{70}\text{Fe}_5\text{Si}_{15}\text{B}_{10}$ . The alloy was formed into a 30 mm ribbon by tempering from a liquid state in a rapidly revolving cylinder. Optimum saturation was at a temperature of 573°K for 600 seconds; no crystalline phase was noted after this processing. The absorption coefficient of the radiation was determined by applying thin layers of non-radioactive nickel on the surface of the alloy sample containing carbon 14. Results indicated that the diffusion mobility of non-metals in amorphous metallic alloys was many times lower than in crystalline alloys. Metallic atoms showed the opposite effect. Figures 2; references 8: 4 Russian, 4 Western.  
[174-12131]

## EVALUATION OF THE ROLE OF DIFFUSION CREEP IN SUPERPLASTIC DEFORMATION

Ordzhonikidze IZVESTIYA VYSSHIKH UCHEBNIKH ZAVEDENIY: TSVETNAYA METALLURGIYA in Russian No 3, May-Jun 83 (manuscript received 3 Jun 82)  
pp 81-84

VALIYEV, R. Z. and SERGEYEV, V. I., Ufa Aviation Institute, Department of General Technology and Metal Studies

[Abstract] Superplastic deformation of ultra-finegrained materials involves activation of diffusion processes that can lead to diffusion creep. This process can be studied by measuring separation-free zones only where deformation temperatures are stable. The present study presents results of measurement of deformation zones formed on a previously polished sample during the course of superplastic deformation. Differing results of related earlier investigations led the authors to compare variants of the method using the same MA-8 magnesium alloy ( $\text{Mg}+1.5\%\text{Mn}+0.3\%\text{Ce}$ ), which is superplastic at a granule size of approximately 10 mkm and a temperature of 400°C. Results of regular and electron microscope examination indicated the redistribution of disperse particles leading to formation of separation-free zones near transverse granule boundaries, and increased longitudinal density of particles.

Diffusion creep as well as granule-boundary slippage and granule migration were judged to be involved in the restructuring process, which was more pronounced in surface layers than in deeper zones. The method of evaluating the role of diffusion creep in superplastic deformation by the breadth of surface deformation zones was found to be incorrect for the tested alloy. Figures 2; references 13: 6 Russian, 7 Western.  
[161-12131]

- END -