

LOAN DOCUMENT

PHOTOGRAPH THIS SHEET

DTIC ACCESSION NUMBER



LEVEL

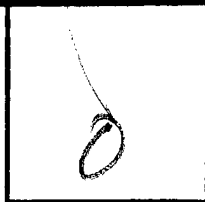

INVENTORY

AFRL-ML-TV-TR-1999-4525

DOCUMENT IDENTIFICATION

22 MAR 99

DISTRIBUTION STATEMENT A
Approved for Public Release
Distribution Unlimited

DISTRIBUTION STATEMENT

ACCESSION FOR	
NTIS	ORAM
DTIC	TRAC
UNANNOUNCED	
JUSTIFICATION	
BY	
DISTRIBUTION/	
AVAILABILITY CODES	
DISTRIBUTION	AVAILABILITY AND/OR SPECIAL
A-1	

DISTRIBUTION STAMP

--

DATE ACCESSIONED

--

DATE RETURNED

19990611 078

DATE RECEIVED IN DTIC

--

REGISTERED OR CERTIFIED NUMBER

PHOTOGRAPH THIS SHEET AND RETURN TO DTIC-FDAC

H
A
N
D
L
E

W
I
T
H

C
A
R
E

AFRL-ML-TY-TR-1999-4525



**EVALUATING ZETA POTENTIAL AND THE
CALCITE/ARAGONITE RATIO AS INDICATORS OF
SUCCESSFUL MAGNETIC WATER TREATMENT**

KEVIN M. LAMBERT

**DEPARTMENT OF CIVIL AND ENVIRONMENTAL ENGINEERING
BRIGHAM YOUNG UNIVERSITY
PROVO UT 84602**

Approved for Public Release; Distribution Unlimited

**AIR FORCE RESEARCH LABORATORY
MATERIALS & MANUFACTURING DIRECTORATE
AIRBASE & ENVIRONMENTAL TECHNOLOGY DIVISION
TYNDALL AFB FL 32403-5323**

NOTICES

WHEN GOVERNMENT DRAWINGS, SPECIFICATIONS, OR OTHER DATA INCLUDED IN THIS DOCUMENT FOR ANY PURPOSE OTHER THAN GOVERNMENT PROCUREMENT DOES NOT IN ANY WAY OBLIGATE THE US GOVERNMENT. THE FACT THAT THE GOVERNMENT FORMULATED OR SUPPLIED THE DRAWINGS, SPECIFICATIONS, OR OTHER DATA DOES NOT LICENSE THE HOLDER OR ANY OTHER PERSON OR CORPORATION, OR CONVEY ANY RIGHTS OR PERMISSION TO MANUFACTURE, USE, OR SELL ANY PATENTED INVENTION THAT MAY RELATE TO THEM.

THIS REPORT IS RELEASABLE TO THE NATIONAL TECHNICAL INFORMATION SERVICE (NTIS). AT NTIS, IT WILL BE AVAILABLE TO THE GENERAL PUBLIC, INCLUDING FOREIGN NATIONS.

THIS TECHNICAL REPORT HAS BEEN REVIEWED AND IS APPROVED FOR PUBLICATION.

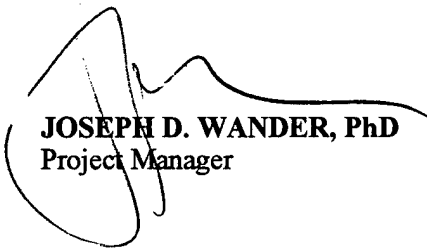

JOSEPH D. WANDER, PhD
Project Manager



CHRISTINE WAGENER-HULME, Lt Col, USAF, BSC
Chief, Environmental Technology Development Branch



ANDREW D. POULIS
Scientific & Technical
Information Program Manager

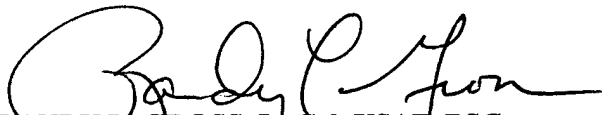

RANDY L. GROSS, Lt Col, USAF, BSC
Chief, Airbase & Environmental
Technology Division

IF YOUR ADDRESS HAS CHANGED, IF YOU WISH TO BE REMOVED FROM OUR MAILING LIST, OR IF THE ADDRESSEE IS NO LONGER EMPLOYED BY YOUR ORGANIZATION, PLEASE NOTIFY AFRL/MLQP, TYNDALL AFB, FLORIDA 32403-5323, TO HELP MAINTAIN A CURRENT MAILING LIST.

Do not return copies of this report unless contractual obligations or notice on a specific document requires its return.

REPORT DOCUMENTATION PAGE			Form Approved OMB No. 0704-0188	
Public reporting burden for this collection of information is estimated to average 1 hour per response, including the time for reviewing instructions, searching existing data sources, gathering and maintaining the data needed, and completing and reviewing the collection of information. Send comments regarding this burden estimate or any other aspect of this collection of information, including suggestions for reducing this burden, to Washington Headquarters Services, Directorate for Information Operations and Reports, 1215 Jefferson Davis Highway, Suite 1204, Arlington, VA 22202-4302, and to the Office of Management and Budget, Paperwork Reduction Project (0704-0188), Washington, DC 20503.				
1. AGENCY USE ONLY (Leave blank)	2. REPORT DATE 22 March 1999	3. REPORT TYPE AND DATES COVERED Final December 1998 - March 1999		
4. TITLE AND SUBTITLE Evaluating Zeta Potential and the Calcite/Aragonite Ratio as Potential Success Indicators for Magnetic Water Treatment			5. FUNDING NUMBERS F08637-98-M-6002	
6. AUTHOR(S) Lambert, Kevin				
7. PERFORMING ORGANIZATION NAME(S) AND ADDRESS(ES) Department of Civil and Environmental Engineering Brigham Young University Provo, UT 84602			8. PERFORMING ORGANIZATION REPORT NUMBER	
9. SPONSORING/MONITORING AGENCY NAME(S) AND ADDRESS(ES) AFRL/MLQE 139 Barnes Drive, Ste 2 Tyndall AFB FL 32403-5323			10. SPONSORING/MONITORING AGENCY REPORT NUMBER AFRL-ML-TY-TR-1999-4525	
11. SUPPLEMENTARY NOTES				
12a. DISTRIBUTION AVAILABILITY STATEMENT Approved for Public Release; Distribution Unlimited ASC-99-1225			12b. DISTRIBUTION CODE A	
13. ABSTRACT (Maximum 200 words) The potential benefits of anti-scale magnetic treatment (AMT) are not realized or reliably predicted because the factors measuring performance of magnetic treatment have either not been identified or are poorly defined. This report focuses on examination of certain measurable outcomes influencing the impact of AMT using magnetic treatment devices (MTDs). The outcomes analyzed in this research were: zeta potential of aqueous samples, relative proportion of calcium carbonate (CaCO ₃) crystal phase and iron content present in solid residue removed from the operating system. The results presented here build on previous research that examined the impact of numerous system operating parameters and four measurable outcomes. The zeta potential was measured at the start and end of each system test. It was believed that a decrease in this measure would indicate decreased charged particle repulsion, increasing potential for particle coagulation. It was supposed this might favor the transport of CaCO ₃ particles through the system rather than fostering scale formation on pipe walls. The data showed that the zeta potential increased from start to end of tests whether MTDs were installed or not. Many other factors, including chemistry, presence of contaminants, sample preparation and evaluation methodology can impact the measured quantities of calcite and aragonite in CaCO ₃ . It was concluded that this approach is not a good measure of whether AMT works successfully or not.				
14. SUBJECT TERMS anti-scale magnetic treatment, magnetic treatment devices, zeta potential, calcite, aragonite			15. NUMBER OF PAGES 60	
			16. PRICE CODE	
17. SECURITY CLASSIFICATION OF REPORT Unclassified	18. SECURITY CLASSIFICATION OF THIS PAGE Unclassified	19. SECURITY CLASSIFICATION OF ABSTRACT Unclassified	20. LIMITATION OF ABSTRACT UL	

UNCLASSIFIED

SECURITY CLASSIFICATION OF THIS PAGE

CLASSIFIED BY:

DECLASSIFY ON:

ACKNOWLEDGEMENTS

The following organizations are recognized for their financial support of this research:

- US Air Force Civil Engineer Support Agency (AFCESA), Tyndall AFB, FL
- Brigham Young University, Provo, UT

The following organizations provided equipment, laboratories and technical support:

- Geology Department, Brigham Young University
- Department of Civil and Environmental Engineering, Brigham Young University

US Air Force contacts providing technical and contract support:

- Dr. Joe Wander – US Air Force Research Laboratory, Materials and Manufacturing Directorate, Airbase and Environmental Technology Branch (AFRL/MLQ), Tyndall AFB, FL
- Mr. Sol Williams – US Air Force Civil Engineer Support Agency (AFCESA), Tyndall AFB, FL

EXECUTIVE SUMMARY

The potential benefits of anti-scale magnetic treatment (AMT) are not realized or reliably predicted because the factors determining success or failure of magnetic treatment have either not been identified or are poorly defined. This report focuses on examination of certain measurable outcomes that have been proposed by others as being indicators of or factors influencing the impact of AMT using magnetic treatment devices (MTDs). The outcomes analyzed in this research were: zeta potential of aqueous samples, relative proportion of calcium carbonate (CaCO_3) crystal phase and iron content present in solid residue removed from the operating system.

The results presented herein build on previous research that examined the impact of numerous system operating parameters and four measurable outcomes. All test system operating parameters were fixed except the number of MTDs installed. Elimination of one analytical outcome (particle size distribution) and the fixing of numerous system test parameters was based on the prior research. Testing, sampling and analyzing protocols were all improved with the intent of reducing data variation to strengthen conclusions.

Water measures (pH, alkalinity, hardness, temperature) established that the new protocols reduced chemistry and temperature fluctuations. Analysis of the system water at the start of testing showed that one factor significantly influenced total iron content in the water – that of the date of testing. This appeared to be tied to source water changes. This test date phenomenon was the only factor to show a significant impact on the iron content in the solid residue removed from test filters. This result did not confirm the trend of decreasing residue iron content with increasing number of MTDs installed, that was reported in the previous research. The magnitude of the test date related iron content change was larger than the previously noted trend, which may have influenced these results.

The zeta potential was measured at the start and end of each system test. It was believed that a decrease in this measure would indicate decreased charged particle repulsion, increasing potential for particle coagulation. It was supposed this might favor the transport of CaCO_3 particles through the system rather than fostering scale formation on pipe walls. The data showed that the zeta potential increased from start to end of tests whether MTDs were installed or not. One and three MTDs installed showed about the same magnitude effect as no AMT,

while the presence of six installed MTDs experienced about three times the change in zeta potential. Data variability in these measurements make conclusions based on this measure problematic in this instance.

The relative polymorphic phase composition (calcite versus aragonite) has been proposed as an indicator of the impact of AMT on scaling waters. The results found in the current testing show very little variation in the relative composition of calcite and aragonite in the CaCO_3 residue. This agrees with the previous test results found by this author. Many other factors, including chemistry, presence of contaminants, sample preparation and evaluation methodology can impact the measured quantities of calcite and aragonite in CaCO_3 . It was concluded that this approach is not a good measure of whether AMT works successfully or not.

TABLE OF CONTENTS

1.0 INTRODUCTION.....	1
2.0 SCOPE	3
3.0 MATERIALS, EQUIPMENT AND METHODOLOGY	4
3.1 Materials	
3.2 Test System Equipment	
3.3 Analytical Test Equipment	
3.4 Operation of Sample Production and Filtration Test System	
3.5 Sample Evaluation Techniques	
3.6 XRD: Calcite Estimation Technique Calibration	
4.0 RESULTS.....	8
4.1 System Test Parameters	
4.2 Water Chemistry	
4.3 Iron Content in Solid Residue (XRF)	
4.4 Zeta Potential	
4.5 Polymorphic Crystal Phase: Calcite vs. Aragonite (XRD)	
5.0 DISCUSSION OF RESULTS	17
5.1 Water Chemistry	
5.2 Iron Content in Solid Residue (XRF)	
5.3 Zeta-Potential	
5.4 Polymorphic Crystal Phase: Calcite vs. Aragonite (XRD)	
6.0 CONCLUSIONS AND RECOMMENDATIONS.....	21
7.0 REFERENCES.....	23
APPENDICES	
A. TEST SYSTEM SCHEMATIC, SYSTEM PHOTOGRAPH, MTD SKETCHES.....	25
B. DETAILED TEST AND SAMPLING PROCEDURES.....	28
C. TABULATED ANALYTICAL DATA	35

Zeta Potential Results For System Tests

Iron Content In Filter Residue By XRF
 Total Iron In Water Samples By FAA
 XRD Peak Areas – System Test Samples

D. XRD PEAK PLOTS FOR CALCIUM CARBONATE CRYSTAL PHASE 41

LIST OF FIGURES

Figure	Page
1. XRD Calibration Plot	8
2. Residue Iron Content Versus Number of Installed MTDs	14
3. Average Change in Zeta Potential From Start to End of System Tests	16
4. Calcite % in Residue vs. Number of MTDs.....	17
5. Test System Schematic.....	26
6. Overall View of Test System 1	26
7. Views of magnetic device attached to section of pipe.	27

LIST OF TABLES

Table	Page
I. XRD Calibration Plot Data For Calcite	7
II. System Test Parameter Summary.....	9
III. Water Chemistry - Hardness, Alkalinity, pH	10
IV..Comparison of Water Chemistry: Current vs. Thesis Research	11
V. Estimated Total Iron in Water Samples.....	11
VI. Iron Counts (XRF) For Different Test Result Groupings	13
VII. Zeta Potential Summary Of System Test Samples	15
VIII. Comparison of Calcite Percent in Residue for Different System Test Parameters	17
IX. Zeta Potential Results For System Tests	36
X. Total Iron in Water Samples by Flame Atomic Absorption	38
XI. Iron Content in Filter Residue Samples by XRF	39
XII. XRD Peak Areas (cpm) - December, 1998 System Test Samples	40

EVALUATING ZETA POTENTIAL AND THE CALCITE/ARAGONITE RATIO AS INDICATORS OF SUCCESS MAGNETIC WATER TREATMENT

1.0 INTRODUCTION

Chemical additives are often used to control hard water scaling of heat transfer surfaces. This imposes significant costs and maintenance. Where the chemicals do not completely solve the problem, acid cleaning, physical scraping or replacement of equipment is required, at additional financial and environmental costs. A number of benefits may accrue from the non-chemical suppression of scaling: decreased chemical use, reduced energy consumption, lower labor requirements, decreased undesirable discharges, reduced water use and extended service lifetimes of equipment. These environmental and economic benefits are not reliably predicted because the factors determining success or failure of non-chemical means such as magnetic treatment have either not been identified or are poorly defined.

A small sampling of the literature on the subject shows examples of successful field applications (MacGarva, 1993; Simpson, 1980; Raisen 1984) and measured effects due to magnetic treatment in the laboratory (Duncan, 1995; Busch and Busch, 1996). Other researchers have shown no effect or inconclusive evidence for the commercial magnetic devices tested (Lawrence, 1984; Limpert and Raber, 1985; Hasson and Bramson, 1985). For a larger discussion of the literature see Baker and Judd (1996). Broad conclusions that may be drawn from reading the literature is that the commercial devices do not work equally well and that there may be numerous situations where none will work due to inappropriate application. Several problems exist with the use of magnetic treatment devices (MTDs) for anti-scale magnetic treatment (AMT) including: lack of successful replication of many experiments, poor field trial controls, lack of definitive causal mechanisms and clear cut success in all claimed applications. However, there is sufficient evidence of well-defined changes in laboratory experiments and successful field applications to merit further research. The second international symposium held in England in 1996 (Cranfield University, 1996) attended principally by university researchers demonstrates recent international research interest in the subject.

The "Study of Factors Related to Magnetic Treatment of Calcium Carbonate Saturated Water" (Lambert, 1998) (hereinafter referred to as the Thesis) contains a brief history of the research and field work on this topic. It summarizes the various test parameters evaluated and the experimental outputs measured. The Thesis provides examples of both "successful" and "unsuccessful" magnetic device testing and discusses reasons for the conflicting results reported. The Thesis mentions some of the classifications of mechanisms proposed for the anti-scaling properties attributed to the magnetic treatment devices (MTDs) and discusses selected proposed mechanisms.

This report covers the results of additional testing beyond the scope of the originally funded research reported in the Thesis (Lambert, 1998). This additional work focused on tightening procedural controls to improve data reliability. It repeated tests (performed during the previous research) only for those system test parameters most likely to provide contrast between magnetically and non-magnetically treated waters over-saturated with calcium carbonate. Resulting aqueous and solid, residue samples were analyzed for particle surface charge, iron content and calcium carbonate polymorphic crystal phase (calcite vs. aragonite).

Reduction of surface charge on colloidal particles to foster flocculation and coagulation is an accepted phenomenon in water treatment. Some AMT field applications have reported that reduced scaling on heat transfer surfaces was accompanied by increased deposition of calcium carbonate crystal sludge in slow flow regions of the industrial system. This may be explained if reduced surface charge leads to microscopic particle coagulation. Larger crystals in suspension (in the bulk fluid flow) favors crystal growth at the expense of smaller crystals (which may be forming on solid-liquid interfaces). This sequence of events is briefly proposed in Lambert (1998). However, the author is unaware of any theoretical mechanism for surface charge reduction by magnetic field exposure currently published. Several researchers have found reductions in zeta potential (a measure of surface potential) with application of AMT (Parsons, et al, 1997 and Higashitani, 1996).

Calcium carbonate is frequently found in two polymorphic forms - calcite and aragonite - which are identical in chemical composition, but differ in density and crystal structure and shape. Several researchers have reported significant changes in the relative composition of the calcium carbonate crystal phase (Baker and Judd, 1996; Pandolfo, 1987),

which they attributed to anti-scale magnetic treatment (AMT) of water. The changes most commonly reported in the literature for precipitated calcium carbonate crystals are noted below.

Crystals precipitated from aqueous solutions without AMT are composed principally of calcite (Duffy, 1977), 70 – 80% being the most commonly reported range (Deren, 1985; Donaldson, 1990), and the remainder being aragonite. After solutions flow through MTDs the precipitated crystals are found to be primarily aragonite (Higashitani, et al., 1993) (70 – 80% has been reported by several publications) with the balance composed of calcite. Adherent scale removed from pipe and heat exchanger surfaces has generally been determined to be composed mostly of the calcite phase. However, Cowan and Weintritt (1976) indicate that it is principally composed of aragonite. Precipitated crystals removed from the bulk fluid (by filtration or settling in quiescent zones) generally have been shown to be mostly aragonite. With different crystalline shapes, densities, and ions that can substitute into the respective crystal lattices for calcite and aragonite, there are some significant differences between these two phases. Some researchers believe that this noticeable effect is tied to the scale reduction phenomenon.

A method for observing changes in iron concentration with the presence of MTDs was sought since iron content can significantly influence calcium carbonate crystal formation or growth (Hasson and Bramson, 1985; Meyer, 1984).

2.0 SCOPE

The current research effort was intentionally focused on a much more limited test approach than the original research reported in the Thesis. Greater emphasis was placed on increased control of test procedures and sample analyses with an attendant decrease in the number of system operating parameters examined. The focus was on the test parameters most likely to confirm the most promising conclusions reached in the Thesis research.

The only system operating parameters varied in the current effort was the presence and number of MTDs installed on the pipes. Effectiveness of the magnetic treatment was evaluated by examination of aqueous samples by measurement of the zeta potential and examination of crystal residue by X-ray diffraction (XRD) and X-ray fluorescence (XRF). Zeta potential provides a measure of the charged particles' surface potential. XRD evaluation provides the

relative amounts of the CaCO_3 polymorphic crystal phase (calcite vs. aragonite) present in the filter residue. XRF provides the quantity (or relative concentration) of iron in the filter residue.

3.0 MATERIALS, EQUIPMENT AND METHODOLOGY

3.1 Materials

Calcium carbonate, CaCO_3 , ACS reagent, chelometric standard, supplier: Aldrich (CaCO_3 supplier for the Thesis research was Mallinckrodt)

Hydrogen peroxide (H_2O_2), 50% solution (to minimize microbiological growth in the tanks)

Concentrated nitric acid, reagent grade (for acid preservation of samples for iron determination by fluorinated atomic absorption.)

Concentrated hydrochloric acid, reagent grade (for acid rinse of glass sample bottles)

R601 Min-U-Sil Test Colloid, Zeta-Meter, Inc. (used to verify equipment and technique for zeta potential)

Hach Alkalinity test kit (5-400 mg/L) Model - AL-AP MG-L

Hach Total and Calcium Hardness test kit (10-4000 mg/L) Model HAC-DT

Isopropyl alcohol (for buffering and rinsing filter residue in Micronizing grinder sample containers)

3.2 Test System Equipment (significant components only)

Wilden air-operated, double-diaphragm pump, designation: M.025/PPPD/WF/WF/PWF

The Equalizer™, Wilden automatic surge dampener, Wilden Pump & Engineering Co.

Mini-Trol Model 500 shock suppressor, Amtrol, Inc.

filter membrane: Nuclepore polycarbonate, 10.0- μm pore, track etched, 47-mm diameter

depth filter (for upstream pre-screening): Osmonics polyester drain disc, 42-mm diameter

fused quartz, Red Hot Immersion Heater, 300- and 400- watt BD series, Electrothermal Engineering Ltd.

Robotemp, heat controller Model No. 315, George Ulanet Co.

Barnant Series 10 variable-speed mixer motor

Magnetic device model number M1-C, The Magnetizer Group, Inc.
handheld pH meter: pH Tester BNC, ordered through Cole-Parmer
Fluke 51 K/J digital thermometer

3.3 Analytical Test Equipment

X-ray Fluorescence (XRF): Siemens SRS 303

X-ray Diffraction (XRD): XDS 2000, Scintag Inc., USA

Zeta Meter 3.0, Zeta-Meter, Inc.

Flame Atomic Absorption (FAA): Thermo Jarrell Ash model number 11

3.4 Operation Of Sample Production And Filtration Test System

Two identical design test systems were built and operated to perform several functions: 1) to provide a water circulation path through magnetic treatment devices (MTDs); 2) to simulate industrial pipe flow through typical flow-disturbing fittings (valves, tees, reducers, meters, bends, etc.); 3) to provide a water storage tank for chemical mixing, and water heating; 4) measurement capability for flow, pressure, temperature and pH; 5) to allow filtration and removal of suspended CaCO_3 crystals; 6) to afford easy access for taking water samples; 7) to eliminate metal contact with the flowing water.

A test system schematic, an overall system photograph and sketches of the MTD are found in Appendix A. Detailed assembly drawings and additional system photographs are found in Appendix A of the Thesis (Lambert, 1998). System operation is described in great detail in Appendix B of this report. System operation was essentially the same as used for the Thesis research, although it has been described in greater detail here than in the Thesis. The only improvement in system operation over the Thesis research was in reducing the water temperature variation by better temperature and heat controller monitoring. The water source used for the testing was considered moderately hard water.

3.5 Sample Evaluation Techniques

In the quest to improve data quality, the sampling procedures were made more specific and detailed than were previously used in the Thesis research. This included tighter specification of the water sampling depth and lateral locations within the tank; acidic preservation of the water samples for iron content; allowing all water chemistry and zeta potential samples to approach room temperature prior to analysis; better sample concentration procedures for the iron/water samples; better sample bottle cleaning techniques, and better water sample swirling prior to measuring zeta potential and alkalinity or hardness. All of this effort was intended to reduce data variation and strengthen conclusions from analytical results. Detailed sampling procedures, sample preparation and sample bottle cleaning techniques are described in Appendix A of this report.

Some detailed comments are also included in Appendix A regarding the XRF and XRD examinations that were slightly different from what was conducted previously. These operational details should not affect data comparisons between the current results and those previously obtained in the research reported in the Thesis. Descriptions of the different analytical techniques used here are described in the Thesis (Lambert, 1998). Zeta Meter: Thesis section 5.5.4, page 24. X-ray diffraction: Thesis section 5.5.5, page 27. X-ray fluorescence: Thesis section 5.5.7 page 32. Flame atomic absorption: Thesis section 5.5.2, page 21.

3.6 XRD: Calibration of Technique for Calcite Estimation

What is called the calibration function in the Thesis (Lambert, 1998, section 5.5.5.4) is a way of combining the measured diffraction peak areas to produce an estimate of the amount of calcite in the residue as a percentage of the total calcium carbonate. A way was needed to compare this mathematical technique against samples of known composition of calcite and aragonite to confirm its accuracy. The previously used calibration technique and data were reevaluated during the current effort to see if any accuracy improvement could be achieved. The calibration data are presented in Table I and plotted in Figure 1. Two areas were affected. First, the raw XRD data plots for all the known composition sample powders were reexamined. The diffraction patterns for all but one of the calibration samples showed very little presence of

extraneous, foreign substances. The plot of the nominally 20% calcite and 80% aragonite calibration sample showed significant presence of unknown substances which were not apparent in the tabulated data (because only calcite and aragonite peaks were selected). It was the only calibration point that deviated a large amount from a best-fit line of the remaining data. The foreign substance likely affected the diffraction pattern. For this reason this calibration point was ignored. Second, the minimum resolvable peak area was fairly accurately estimated from minimum values of actual measured peaks. The average value of the minimum peak that should be measurable with this particular data is approximately 0.5%, which is lower than what was originally, roughly estimated. This change affects the two end points in the calibration curve, causing it to be a straight, continuous line over the full range of calcite content. The calibration plot is somewhat different from what was previously used.

TABLE I XRD Calibration Plot Data For Calcite

Calcite ratio - calculated from XRD diffraction data	% estimated calcite - based on powder sample preparation
0.98	99%
0.75	80%
0.64	60%
0.46	40%
0.40	20%
0.00	0%

Note: "% estimated calcite" called "corrected calcite %" in Thesis Table D1

Figure 1 shows a very good correlation between the prepared, known composition XRD diffraction samples and the method for estimating the percent calcite from the measured XRD peak areas. Since the correlation is so good, the calculated calcite percentage will not be corrected but used as calculated. These modifications to the calibration were reapplied to the % estimated calcite presented in the Thesis. These changes lowered the "% estimated calcite" presented in the Thesis by 0 – 2%. This small impact on estimated values has no impact on the conclusions previously reached.

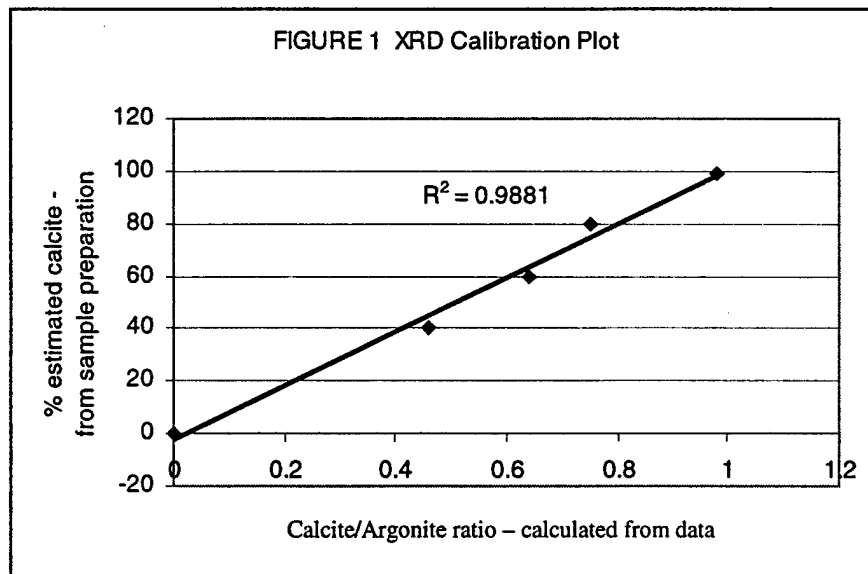

4.0 RESULTS

4.1 System Test Parameters

Table II lists the system test parameters used. Only the number of MTDs installed was varied (other than the use of both test systems). The flow rate of 3 gpm corresponds to an average cross-sectional velocity of 146 ft/min through the PVC pipe the MTDs were mounted on. Table II also lists the mass of the crystalline residue (principally CaCO_3) recovered from the filter membranes after each system test. About 5% more mass was recovered from System 1 filters than from System 2 filters on average, indicating minimal differences in crystal recovery between the two systems.

4.2 Water Chemistry

Table III lists the CaCO_3 added to the system reservoirs (15 gallons of water) prior to heating and circulating to increase the water hardness. This table also lists the alkalinity and calcium and total hardness measured for water sampled just after circulation began for each system test. The water temperature listed was measured just prior to titration for each indicated chemistry test. The pH of the water in each tank is listed for each test. The pH was sampled at the beginning and end of each test and showed no measurement change from beginning to end of each test. The measurement accuracy of the pH meter was listed at +/- 0.1 units.

TABLE II System Test Parameter Summary

Test date	System No.	Test time(hrs)	Number of MTDs	Added CaCO ₃ (mg/L)	Water temperature(F)	Pump rate(gpm)	Mass residue recovered from filter (g)
12/1/98	1	9	3	75	102.6–105.4	3.0	2.418
12/1/98	2	9	3	75	99.4–105.4	3.0	2.686
12/3/98	1	9	1	75	103.8–110	3.0	2.449
12/3/98	2	9	1	75	102.6–114	3.0	2.573
12/5/98	1	9	6	75	104.0–106.8	3.0	3.266
12/5/98	2	9	0	75	105.0–106.2	3.0	2.390
12/8/98	1	9	3	75	104.8–105.8	3.0	2.735
12/8/98	2	9	1	75	104.2–106.8	3.0	2.540
12/10/98	1	9	1	75	104.4–107.6	3.0	2.838
12/10/98	2	9	3	75	102.4–108.2	3.0	2.517
12/12/98	1	9	0	75	103.6–105.6	3.0	2.674
12/12/98	2	9	6	75	105.2–105.8	3.0	2.785
12/17/98	1	9	6	75	103.6–104.6	3.0	3.240
12/17/98	2	9	0	75	101.6–104.8	3.0	3.031
12/19/98	1	9	0	75	103.2–106.6	3.0	2.698
12/19/98	2	9	6	75	104.6–105.2	3.0	2.812
12/30/98	1	9	0	75	103.4–105.4	3.0	3.118
12/30/98	2	9	3	75	104.4–106.2	3.0	2.817

Note: All these tests used Fluids Lab. hose/tap water

The total hardness for System 1 test data for 12/8/98 lists two values: 124/175. The lower value was obtained with a 100-mL sample titrated with 0.8 M EDTA, which was the titration method used on all the other total hardness values presented. This value seemed conspicuously low relative to the other total hardness values obtained from what should have been the same source water. So the chemical measure was repeated using a 25 mL sample titrated with 0.08 Molar EDTA (a slightly different methodology available with the Hach test kit used) which yielded the higher value. The second value (175) produced a higher ratio relative to the calcium hardness than did almost all the other data. Due to the data uncertainty, this particular total hardness was ignored in calculating average values and standard deviations.

TABLE III Water Chemistry - Hardness, Alkalinity, pH

Test date	System No.	No. of MTDs	CaCO ₃ added to tank(g)	Sample Temperatures (F)			Alkalinity (mg/L as CaCO ₃)	Calcium hardness	Total hardness	pH
				Alkalinity	Calcium Hardness	Total hardness				
12/1/98	1	3	4.273	82.5	80	80	158	97	154	8.2
12/1/98	2	3	4.261	82	81	79.5	158	103	158	8.2
12/3/98	1	1	4.269	82	80	79	160	112	164	8.2
12/3/98	2	1	4.268	84	79.5	79	165	106	163	8.2
12/5/98	1	6	4.268	76.5	76	76	155	94	187	8.2
12/5/98	2	0	4.270	78	76	77	145	99	163	8.2
12/8/98	1	3	4.279	78	77	76	150	91	124/175*	8.2
12/8/98	2	1	4.269	76	76	76	148	95	154	8.2
12/10/98	1	1	4.265	80	77	76	143	96	161	8.2
12/10/98	2	3	4.265	80	76	75	155	93	151	8.2
12/12/98	1	0	4.265	84	78	76.5	155	106	179	8.2
12/12/98	2	6	4.273	81	78	76	148	91	147	8.2
12/17/98	1	6	4.274	82	80	78	155	99	196	8.2
12/17/98	2	0	4.276	79.5	78	78	145	95	155	8.2
12/19/98	1	0	4.270	79	76	74	148	101	167	8.1
12/19/98	2	6	4.274	78	75	73	148	103	157	8.1
12/30/98	1	0	4.267	74	75	72	150	95	187	8.2
12/30/98	2	3	4.277	76	73	73	145	96	155	8.2

Note* - Total hardness:124 mg/L obtained with 100 mL sample titrated with 0.8 M EDTA
175 mg/L obtained with 25 mL sample titrated with 0.08 M EDTA

Table IV compares the water chemistry for the most recent system testing against that previously performed by this author and reported in the Thesis (Lambert, 1998). The most recent data show significantly higher values (40–70%) of alkalinity and hardness with lower values of pH. In all cases, the standard deviation of the data most recently obtained is far less than that previously obtained and reported.

Table V lists the estimated range of total iron concentration, and the average of these values for water samples taken at the very start of each system test. This represents the iron content of the tap water used along with any iron derived from the addition of CaCO₃ to the water as it is heated and stirred in the reservoirs. The estimated total iron range represents some changes to the raw data presented in Table X in Appendix C.

TABLE IV Comparison of Water Chemistry: Current vs. Thesis Research

Test data grouping	Value calculated	Alkalinity	Calcium hardness	Total Hardness	pH
		(mg/L as CaCO ₃)			
Current test data	average =	152	98	165	8.19
	standard deviation =	6.1	5.7	14.2	0.03
Thesis test data	average =	99	58	115	8.92
	standard deviation =	34.8	25.4	36.6	0.20

Note: Average values and standard deviations of alkalinity, hardness, pH for system tests using data from tests with 75 mg/L of added calcium carbonate.

TABLE V Estimated Total Iron in Water Samples

System Test date	System Number	Number of MTDs	Estimated Total iron Range (ppm)	Average estimated total iron (ppm)
12/1/98	1	3	.068-.100	0.084
12/1/98	2	3	.051-.080	0.066
12/3/98	1	1	.027-.060	0.044
12/3/98	2	1	.070-.100	0.085
12/5/98	1	6	.026-.050	0.038
12/5/98	2	0	.025-.060	0.042
12/8/98	1	3	.027-.030	0.028
12/8/98	2	1	.026-.050	0.038
12/10/98	1	1	.039-.060	0.050
12/10/98	2	3	.025-.070	0.048
12/12/98	1	0	.040-.072	0.056
12/12/98	2	6	.019-.030	0.024
12/17/98	1	6	.042-.060	0.051
12/17/98	2	0	.021-.030	0.026
12/19/98	1	0	.014-.020	0.017
12/19/98	2	6	.020-.050	0.035
12/30/98	1	0	.035-.050	0.042
12/30/98	2	3	.014-.020	0.017

Notes:
 Average of all 'average estimated total iron' values = 44 ppb
 Average standard deviation from raw data = 36 ppb
 Maximum value from 'estimated total iron range' = 100 ppb
 Mimimum value from 'estimated total iron range' = 14 ppb
 Samples taken from tanks at start of system tests.

The procedure called for Flame Atomic Absorption (FAA) analysis of two water samples from each system test. One was to be from an unconcentrated water sample while the second sample was to be concentrated in the desired range of 15 to 30 times as a confirmation of concentration values nearing the Method Detection Limit (MDL). In some instances there was insufficient water sample remaining after the concentration procedure to provide for accurate FAA analysis, so these data are missing from the raw data table. The majority of system tests have two measured values to provide a range of expected iron concentration. From this set of data it was learned that the concentrated sample iron levels averaged 0.70 times the iron levels measured for the unconcentrated water samples. This ratio was used (where necessary in Table V) to estimate iron levels in samples for which there was no accurate, measured concentration. In two cases, the measured iron concentration fell below 0.030 ppm. In these two cases the concentrations were assumed to be 0.020 ppm (since some iron is known to exist in all the water samples) for purposes of Table V. Considering the low value, the absolute error in this estimate will be small.

The estimated or measured total iron in the system test water varied from a minimum of 14 ppb to a maximum of 100 ppb, with an average of 44 ppb. The average standard deviation of measured data was 36 ppb.

The standard deviation may be high relative to the mean because the mean is so close to the MDL. Evaluation of this data against variation in system test parameters shows no systematic variation. However, there is a date related variation in the data. The average iron content for the tests conducted 1 and 3 December 1998 was 70 ppb while the average for the rest of the tests show an average iron concentration of 36 ppb. This may be explained by the relative amounts of water supplied from the two sources (ground versus surface) that Provo city mixes in their water supply. These values compare with 10–23 ppb iron measured in Provo's city water supply in previous years (closer to the water sources) as reported in the Thesis (Lambert, 1998).

Additional iron is known to come from the added CaCO_3 and potentially from additional supply line piping.

4.3 Iron Content in Solid Residue (XRF)

Table XI in Appendix C lists the measured peak counts (principal K alpha 1 peak) for the individual test samples removed from each system filter. The counts represent individual iron atoms counted in each sample. As each residue sample was very nearly the same mass (+/- 0.8% of the mean) these counts essentially represent a comparative iron concentration in these samples. Comparisons of data groupings is more useful than looking at the raw data. Table VI lists the average value and standard deviation for different groupings of the iron content data obtained by XRF analysis. The first comparative grouping is for System 1 data versus System 2 data. This is indicative of the impact of data variability and differences in the test systems. These System 2 average iron counts run nearly 12% higher than System 1 averages. System 2 data also experiences a 55% higher data standard deviation. The second data grouping is split by system test date along the same date lines where noticeable differences were observed in the water iron content. The earliest December test data have 43% higher iron counts in the residue than do the later December data.

TABLE VI Iron Counts (XRF) For Different Test Result Groupings

Test Result Grouping	Counts for K alpha 1 peak height (kcps)	
	Average Value	Standard Deviation
Test system 1	0.378	0.083
Test system 2	0.422	0.129
Dec. 1 & 3 tests	0.519	0.108
Dec. 5 – 30 tests	0.363	0.074
System 1, 0 MTDs	0.314	0.004
System 1, 1 MTDs	0.397	0.054
System 1, 3 MTDs	0.486	0.070
System 1, 6 MTDs	0.318	0.033
System 2, 0 MTDs	0.437	0.058
System 2, 1 MTDs	0.509	0.218
System 2, 3 MTDs	0.439	0.105
System 2, 6 MTDs	0.304	0.020

The last test result grouping in Table VI splits the data up by test system and the number of MTDs installed. The data for each test system and for the average of the two systems are plotted against the number of

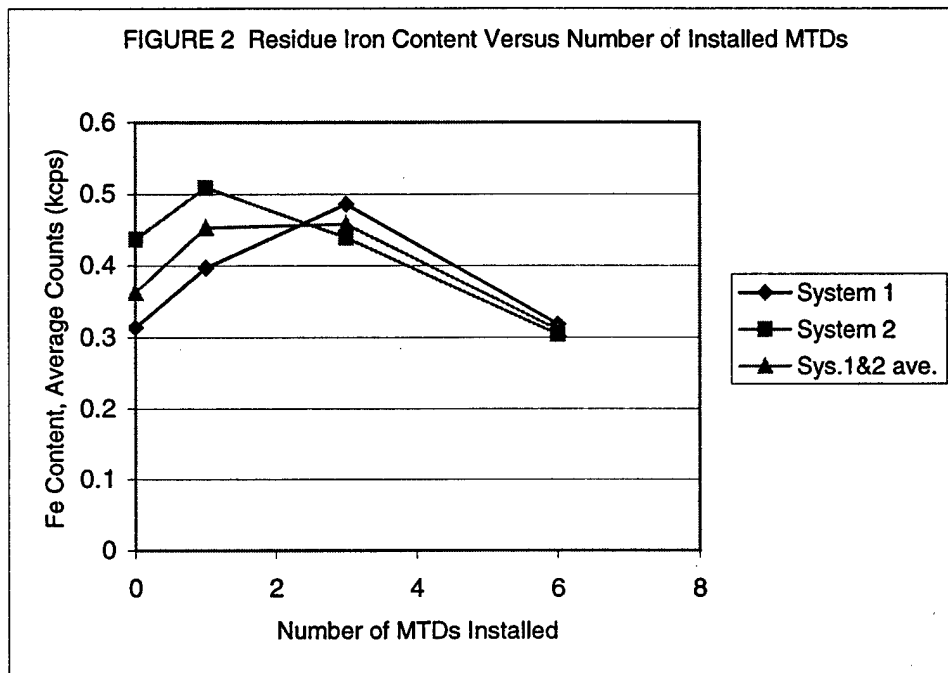

installed MTDs in Figure 2. While there are some differences between the two systems, they exhibit similar trends. The residue iron content increases with one or three MTDs installed and then drops for six installed MTDs.

4.4 Zeta Potential

The zeta potential of water samples taken at the start and end of each system test was measured for 50 separate particles to achieve more reliable results. Still there was significant variation in the measured values as demonstrated by the zeta potential standard deviation listed in the complete data table (Table IX in Appendix C). With one exception (at 63%), the standard deviation in the measured zeta potential from a single system test sample ranged from 15 to 40 % of the average value listed in Table IX. The measured values were averaged for all tests with the same number of MTDs installed and listed in Table VII. Along with these average values are the standard deviations for the four or five values averaged for the start or end sample for each

system test. Table VII also lists the delta magnitude zeta potential between the end and start of each system test. The change in magnitude from start to end is plotted in Figure 3 for each group of tests with the same number of installed MTDs.

TABLE VII Zeta Potential Summary Of System Test Samples

Average zeta potential values listed are corrected to 22.5 C (millivolts)								
	6 MTDs installed		3 MTDs Installed		1 MTD installed		0 MTDs installed	
	Average	Standard Deviation	Average	Standard Deviation	Average	Standard Deviation	Average	Standard Deviation
Sampled at start of test	-16.7	2.39	-17.7	2.31	-16.6	1.10	-18.2	0.75
Sampled at end of test	-20.4	3.05	-18.8	1.78	-17.9	0.51	-19.3	2.70
Delta magnitude* end z.pot.- start z.pot.	3.7	1.55	1.1	2.34	1.2	1.17	1.1	3.16
No. of sample events for start & end of test	4	NA	5	NA	4	NA	5	NA
Notes: NA = not applicable								
*The "Delta magnitude" values are listed as absolute values.								

Figure 3 shows that the magnitude of the average zeta potential increased from start to end of the system tests. With 0 to 3 MTDs installed the zeta potential increased about 6–7 %, but with 6 MTDs installed the potential increased about 20%.

The zeta potential data in Table IX (Appendix C) were examined for impacts due to variations in other system parameters. It was noted that the average System 2 zeta potential was 1.8 times the System 1 zeta potential. No explanation was found for the magnitude of this variation. Water chemistry measurements showed little difference between the two systems, and no other measured output showed a large difference between the systems.

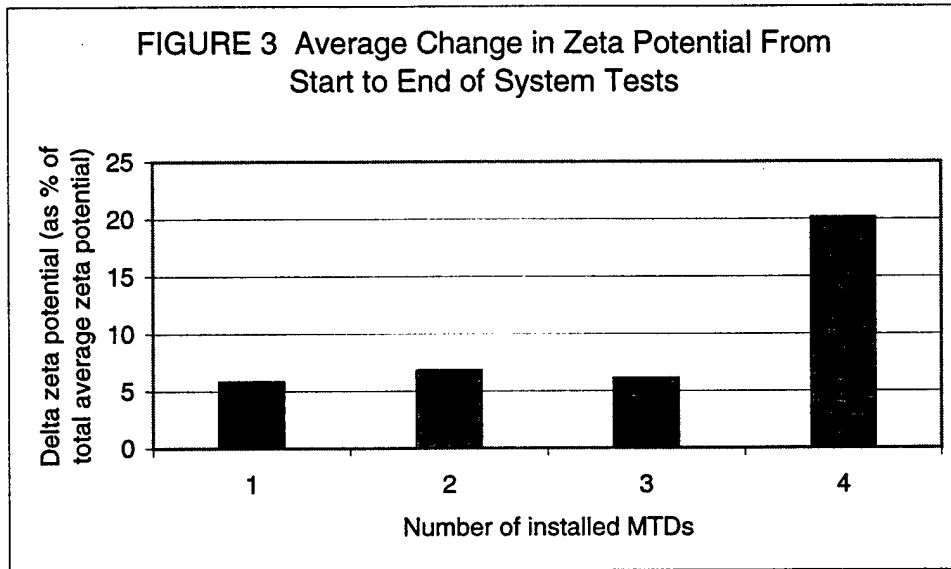

4.5 Polymorphic Crystal Phase: Calcite vs. Aragonite (XRD)

The XRD results indicated that there were few extraneous substances in the residue removed from the test system filters. For purposes of examining the relative proportions of calcite and aragonite, the assumption was made that 100% of the residue was calcium carbonate in one of these two phases. This assumption simplifies but does not affect the accuracy of the examination of these two crystal phases. Table VIII compares the calcite content in the solid residue as a percent of the total CaCO_3 present versus changes in different test parameters. The comparison of the test system showed nearly identical results. The system test dates were split up at the same point that the iron content data was split up. This was done to look for possible impacts due to the significant change in iron concentrations in the water (and solid residue) observed with this same split in test dates. However, the calcite percent showed no significant change. The calcite percentage versus the number of installed MTDs is plotted in Figure 4. Again, there is no significant variation in the calcite percentage.

TABLE VIII Comparison of Calcite Percent in Residue for Different System Test Parameters

Parameter used for comparison	Parameter designation	Percent calcite in residue	
		Mean	Standard deviation
System number	1	98.2	1.1
	2	97.1	1.8
System test date	Dec. 1 – 3	99.0	1.4
	Dec. 5 – 30	97.3	1.4
Number of MTDs installed	0	97.2	0.8
	1	98.0	1.8
	3	97.6	1.8
	6	98.0	2.2

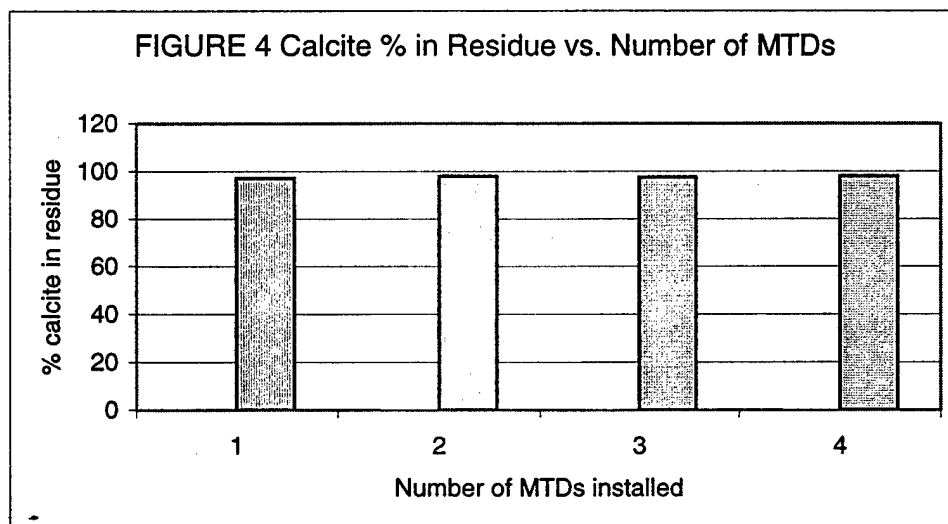

5.0 DISCUSSION OF RESULTS

5.1 Water Chemistry

Comparison of the water chemistry for the currently reported results and that previously obtained (Table IV) indicate that the newly incorporated test and analytical methodology improvements reduced variation in water chemistry. Several other factors likely affected data

variation between the two groups of test data. 1) The much larger set of data previously obtained may include larger swings in values. 2) The previous data (in Table IV) was taken from a four-month test period (January – April, 1998) while the most recent system testing was all conducted during December, 1998. It is known that the city of Provo water supply is supplied from two sources (ground and surface) that vary in their chemical properties. The properties vary slightly with the season, and the split between the two sources also varies seasonally. The longer season provides opportunity for greater source water property variation. 3) The previously measured water chemistry was determined based on titrations done at more varied sample temperatures. This is really part of the analytical protocol. It is believed that the large majority of the reduction in water chemistry variation is due to improvements in test system, water sampling and analytical protocols. The higher values of alkalinity and hardness may be in part due to the above mentioned seasonal variations in water supply and in part due to slightly lower average sample temperatures. Calcium carbonate has a higher saturation concentration at lower temperatures. The greater values of alkalinity and hardness in the most recent testing may also be due in part to another change in the analytical protocol. The sample bottles were swirled more vigorously, suspending undissolved CaCO_3 in the bottom of the bottle that was then poured into the flask for the titration operation. The undissolved CaCO_3 may provide additional carbonate ions as they are taken up in the chemical titration process. Both alkalinity and hardness are affected by the concentration of carbonate ions in solution.

The minimum iron content fell within one standard deviation of the mean value while the maximum fell within one and one half standard deviations. Considering how close the lower values were to the MDL and that the mix of water sources varied somewhat, this is considered a reasonable range of iron concentration. Evaluation of Table V data eliminated system test parameter changes as a cause for any potential variation in the iron content in the solid filter residue. Therefore, any systematic variation in solid residue iron content with the number of MTDs installed would be tied to the presence of the MTDs and not to background variations in the water.

5.2 Iron Content in Solid Residue (XRF)

Table VI shows there is data variation, in part due to unknown causes. It may simply be data variation inherent in the combination of testing, sampling and XRF analysis. The iron content in the early December (1, 3) test solid residues was higher by 43% than the average iron content found in the rest of December's (5–30) test residues. The FAA measured total iron in the water for early December tests was 94% higher than the iron content in the water during the rest of December's tests. The large change in solid residue iron content appears to correspond better with this date phenomenon (likely due to source water variations) than to any other system parameter variation. The trend of decreasing iron content with increasing number of installed MTDs reported in the Thesis (Lambert, 1998) research is not confirmed here. However, there may be a strong influence from source water variation that may (or may not) mask the trend. All the higher iron content data for early December comprises one half of the data for one and three MTDs installed. Removing the early December data from consideration significantly reduces the iron counts (0.357 kcps – average for both systems) for one installed MTD while having practically no impact on the iron content (0.462 kcps – average for both systems) for three installed MTDs. It was thought that the presence of additional installed MTDs (with sufficiently strong magnetic fields) might retain additional colloidal iron, thereby reducing the retention of some iron in the solid filter residue. The data do not support this thought.

5.3 Zeta Potential

Figure 3 shows approximately the same magnitude change in zeta potential (6–7% increase from start to end of system tests) for zero, one or three installed MTDs. With six MTDs in place, the zeta potential increase was approximately 20%, or three times the magnitude change for any other number of MTDs installed. Does this mean that there was insufficient magnetic field strength to achieve significant change in the potential until over three magnetic devices were installed? Possibly. However, examination of the data raises two significant questions. First, why would the same change in the potential be experienced with no MTDs attached as with one or three MTDs attached? Any explanation in the literature for this possible phenomenon point to a continuously changing phenomenon rather than an incremental one.

Previous experimental results for the Thesis (and conversations with the zeta meter vendor) indicated that water samples left standing in plastic containers experienced a slight decline in the magnitude of the potential with time not an increase as seen in these results. Just the fact of the water circulating in plastic tanks for nine hours (plus 10–15 hours heating and temperature stabilization time) would seem to favor no change or a slight decrease in zeta potential during the course of the system tests. Perhaps some unknown phenomenon occurs during the system test that causes this slight increase in zeta potential magnitude. This question remains unresolved since little information was found in a search for parameters affecting zeta potential that applies to this specific test situation. Second, a review of the standard deviations of the average “Delta magnitudes” in Table VII reveal that they are of the same magnitude or much larger than the “Delta magnitude” in three of the four cases. This indicates that other, uncontrolled, or at least unrecognized effects, are having large impacts on the measured potential.

5.4 Polymorphic Crystal Phase: Calcite vs. Aragonite (XRD)

No statistically significant change in the relative proportions of calcite and aragonite were found for any system test parameter variation for either the current test results or the previous results obtained in the Thesis research.

A review of the prominent peak areas, c1–c4 and a1–a4, (see Table XII, Appendix C) from the raw XRD data for the CaCO_3 chelometric standards used in the system tests shows two facts. First, no measurable aragonite peaks were found for either standard powder taken untainted from the original containers. Second, the sum of the calcite peak areas for the Aldrich-supplied chemical (22,066 cpm) was 6.5% higher than the sum of the peak areas for the Mallinckrodt-supplied chemical (20,728 cpm). The issues these two facts raise are discussed in the subsequent two paragraphs.

The first fact is important in that the presence of one polymorphic crystal phase favors the growth of larger crystals of the same phase or of new crystals of the same phase. This is one of the principal reasons that calcite is so predominant in the final residue product. The starting chemicals used, the procedures, and the processing time and temperature govern which polymorphic form of calcium carbonate predominates in the final dried powder. This is illustrated in the Thesis (Lambert, 1998) by the use of different procedures and starting

chemicals to produce relatively pure batches of calcite and aragonite XRD calibration sample powders. No commercially available CaCO_3 powder was identified with the calcite or aragonite content mentioned. This may indicate the potential for preferential development of calcite or aragonite due to its dominant presence in the starting chemical (if added to test waters). There are three known ways to eliminate this question of influencing development of calcite versus aragonite in the final product: 1) Consistently use the same supplier and grade of calcium carbonate. 2) Test the unused powders in each case to verify consistent powder diffraction characteristics. 3) Review supplier processing methods to determine whether calcite or aragonite will be favored. The information may not be obtainable for this final approach.

Secondly, the average calcite content for the current test results was 97.7% while for the previous Thesis research it was 90.7%. The most recent results showed an increase of 7.7% in the calcite content relative to the previous results. This is probably largely due to the 6.5% increase in XRD calcite peak areas in the CaCO_3 powder used most recently versus that used in the previous research. With the calculation technique used to estimate the percent calcite present, the higher peak areas (for the starting powders) would raise the estimated calcite percentage even if the same amount of aragonite were present in each sample. The XRD peak areas are influenced by the nature of the powder examined. Apparently the two CaCO_3 powders used had somewhat different diffraction characteristics. While this would affect any comparisons made between the two sets of data, it does not affect comparisons made within the same set of test data using chemical from the same supplier.

Several experienced XRD users expressed their opinion to me that with care they felt I could get within 20% of the actual calcium carbonate phase composition of the solid residue, but doubted I could get closer than 10% of the actual value. Some published sources had claimed XRD results of within 5% of actual values, probably under more limited conditions, and apparently with far more XRD analytical technique development.

6.0 CONCLUSIONS AND RECOMMENDATIONS

The improvement of test, sampling and analytical protocols reduced water chemistry (alkalinity, hardness, pH) variations. However, iron content in the source water did vary significantly during part of the system testing and was shown to have a significant impact on the

iron content in the solid residue retained on the filters. The trend of decreasing solid residue iron content with increasing number of installed MTDs observed in the Thesis research (Lambert, 1998) was not confirmed in the present test results. However, the source water iron concentration variation clouded the interpretation of the residue iron content data, potentially confusing the issue. The variation in residue iron content seemingly attributable to the source water variation was considerably larger than the variation attributed to the presence of the MTDs as reported in the Thesis. There is insufficient data from this author's research to be able to separate these two effects to determine whether the presence of the MTDs has a small but real impact on iron content in the filter residue.

The zeta potential increased from start to end of system tests for both magnetically treated and untreated water. This does not support the proposed assumption that magnetic treatment reduces zeta potential, thereby increasing the probability of particle coalescence and coagulation in the bulk fluid flow. The similar response of treated and untreated waters could indicate that the magnetic treatment in this case had no impact on this measured output. Or the similar response for untreated and treated waters coupled with the large data deviations relative to changes in zeta potential could implicate unknown factors that have significant impact on zeta potential thereby obscuring interpretation of results. It appears that any useful conclusions to be achieved in this area in the future will require more knowledge about what affects surface potential and its accurate measurement and potentially different equipment. Reduced data variability is required before conclusions can be reached on this potential mechanism.

The particular MTD device used, under the system test parameters tested, did not change the relative percent of calcite and aragonite present in filtered residue. This is in agreement with the conclusions reached in the Thesis research. The variation in source water iron concentration had no noted impact on the polymorphic phase of calcium carbonate crystals captured during system tests.

This author concludes that pursuit of this line of research (relative phase composition) is not a worthwhile expenditure of resources based on 1) the lack of evidence demonstrated in my experimental work; 2) the lack of an explanation for why magnetic treatment would affect the polymorphic phase of calcium carbonate or why any effect (if it occurred) could reduce scaling; 3) the existence of many factors that favor the formation of either calcite or aragonite that may

cause a change in the relative composition of these two phases independent of magnetic treatment; and 4) the imprecision inherent in all but the very best XRD methods.

7.0 REFERENCES

- Baker, J. S., and Judd, S. J. (1996). "Magnetic amelioration of scale formation." *Water Research*. 30(2) 247-260.
- Busch, K. W., and Busch, M. A. (1996). "Laboratory studies on magnetic water treatment and their relationship to a possible mechanism for scale reduction." *Proc. of the Second International Meeting on Antiscale Magnetic Treatment* hosted by the School of Water Sciences, Cranfield University, Shrivenham, Wilts, England, March 14, 1996.
- Cranfield University (1996). *Proc. of the Second International Meeting on Antiscale Magnetic Treatment* hosted by the School of Water Sciences, Cranfield University, Shrivenham, Wilts, England, March 14, 1996.
- Duncan, S. L. (1995). "Phase and morphological control of calcium carbonate," Master's thesis, Pennsylvania State University.
- Hasson, D., and Bramson, D. (1985). "Effectiveness of magnetic water treatment in suppressing CaCO₃ scale deposition." *Ind. Eng. Chem. Process Des. Dev.* 24(3)588-592.
- Higashitani, K. (1996). "Effects of magnetic field on stability of nonmagnetic colloidal particles", *Proc. of the Second International Meeting on Antiscale Magnetic Treatment* hosted by the School of Water Sciences, Cranfield University, Shrivenham, Wilts, England, March 14, 1996.
- Lambert, K. M. (1998). "Study of factors related to magnetic treatment of calcium carbonate saturated water," Master's thesis, Brigham Young University.
- Lawrence, D. J. (1984). "Evaluation of commercial magnetic descalers." *CERL Technical Report M-342*, US Army Corp of Engineers. May.
- Limpert, G. J. C., and Raber, J. L. (1985). "Tests of nonchemical scale control devices in a once-through system." *Materials Performance*. (October) 40-45.
- MacGarva, G. J. (1993). "Naval engineers evaluate magnetic boiler feedwater treatment as an alternative to chemicals." *The Coast Guard Engineer's Digest*. 31(253, Spring) 29-36.
- Meyer, H. J. (1984). "The influence of impurities on the growth rate of calcite." *Journal of Crystal Growth*. 66: 639-646.

Parsons, S.A., Judd, S.J., Stephenson, T., Udol, S., and Wang, B-L. (1997). "Magnetically augmented water treatment." *Process Safety and Environmental Protection*. 75(B2 May), 98-104.

Raisen, E. (1984). "The control of scale and corrosion in water systems using magnetic fields." *Paper No.117, Corrosion 84 - N.A.C.E. Conference*, April 2-6, New Orleans, LA., 1-20.

Simpson, L.G. (1980). "Control scale and save energy." *The Coast Guard Engineer's Digest*. 20(No. 205; Winter), 32-34.

APPENDIX A

TEST SYSTEM SCHEMATIC, SYSTEM PHOTOGRAPH, MTD SKETCHES

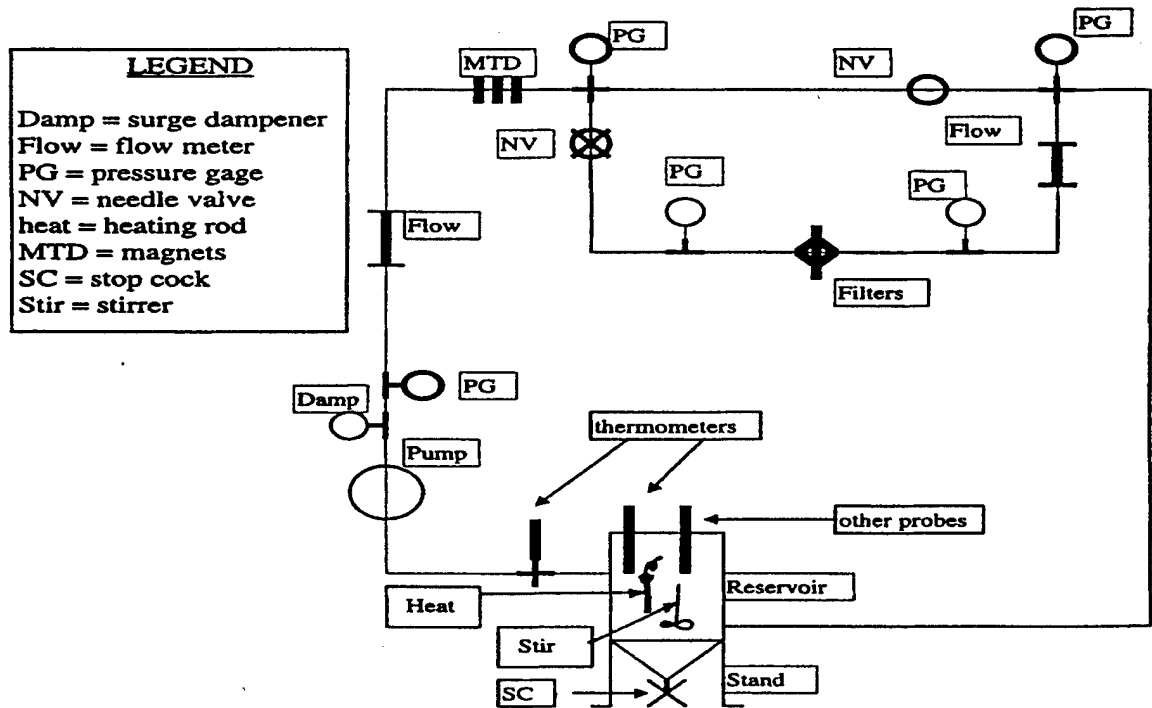

Figure 5. Test System Schematic

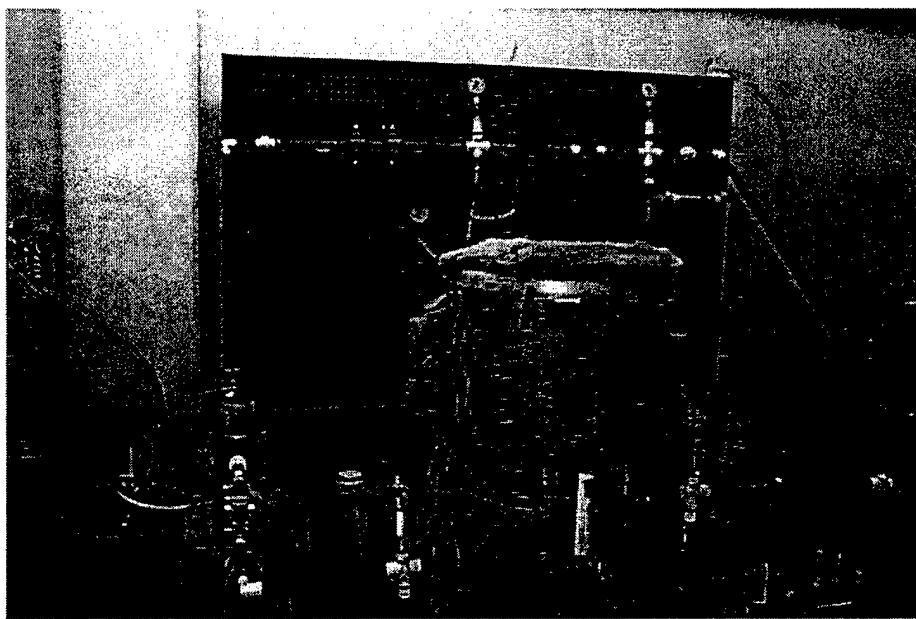
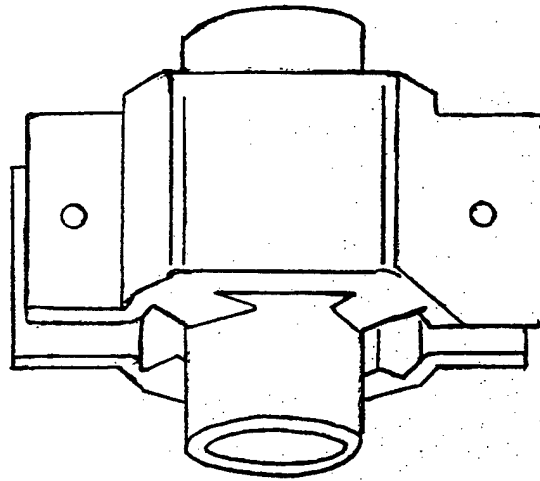
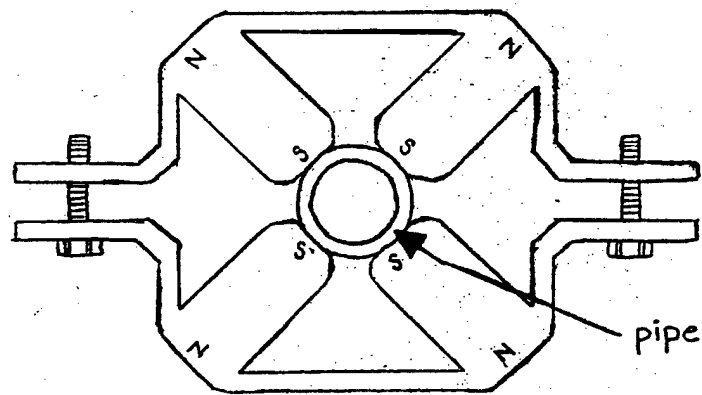

FIGURE 6 Overall view of test system 1. Insulation covers the tank. Digital thermometer on right



a) Side view of magnetic device mounted on pipe



b) Cross-sectional view of magnetic device mounted on pipe

FIGURE 7. Views of magnetic device attached to section of pipe.

APPENDIX B

DETAILED TEST

AND

SAMPLING PROCEDURES

TEST SYSTEM OPERATING PROCEDURE
(MAGNETIC WATER TREATMENT)

A. Prior to the test:

1. Close the hose spigot and tubing valves at the bottom of each tank. Fill both water tanks with 15 gallons each of water from the hose in the Fluids Lab. Let the hose run 2–4 minutes into the sub-floor level water catch basin to flush out residual water in pipe and hose.
2. Add 4.26–4.27 grams CaCO_3 A.C.S. reagent, chelometric standard powder (supplier: Aldrich) to the water in each tank. Record mass of CaCO_3 .
3. Add 1.1 –1.2 mL of 50% hydrogen peroxide solution to the water in each tank.
4. Turn on both immersion heater rods the night before testing is to begin. The immersion heaters should be plugged into the variable voltage controllers overnight. Set knob adjustment based on time and experience.
5. Provide sufficient sample bottles for iron determination (One 300 mL bottle per system test) and for alkalinity, hardness and zeta potential evaluation (two 300 mL bottles per system test).

B. First thing morning of the test:

6. Turn on the tank stirrers to a setting of 4 on the dial.
7. Let stirrers operate 2–5 minutes, then check water temperature in the tanks using the digital thermometer. Let each digital reading stabilize (about 30 – 60 seconds) before recording. Set the digital thermometer to “J” reading mode. (Do this by depressing the top and bottom buttons simultaneously and holding for about 3 seconds. This turns on the digital thermometer.) Adjust variable voltage controllers to achieve 105° F water temperature.

C. While tank water temperatures are stabilizing (this may be done the night before):

8. Make sure the number of magnetic treatment devices (MTDs) attached to each piping system matches the test plan. If not, remove or attach MTDs as required.
9. Close tubing clamps and valves in bypass lines of both systems.
10. Install Osmonics/Poretics polyester drain discs in each of the two blue filter holders.
11. Install Costar/Nucleopore 10 μm pore, track etched filters in the two white filter holders.
12. Release tubing clamps and open the valves in the bypass lines of the two systems.
13. Make sure the oil reservoirs for each pump are full. If not, refill them.

D. Soon after tank water temperature is stabilized:

14. Remove water samples for iron content (One 300-mL bottle) and alkalinity, hardness and zeta potential (one 300-mL bottle).
15. Preserve iron determination water samples by adding nitric acid to $\text{pH} \leq 2$.
16. Open all air supply valves for each test system pump. Pumps begin operation.
17. Check air lines, water pipes and tubing for leaks.
18. On test system data sheets, record date, time, flows, pressures, temperature, etc.
19. Measure and record pH for each water tank.
20. Set water samples for alkalinity, hardness and zeta potential to cool to room temperature.

E. During the test:

21. Using the digital thermometer, check the tank water temperatures. If more than $\pm 1-2^\circ \text{F}$ different from 105°F adjust variable voltage controllers appropriately. Check every 1-2 hours during the first part of the test. If the water temperature remains stable, one need check the temperature only every 2-3 hours.
22. While checking the temperature, record other system operating parameters on the data sheets, at the start and end of the test. Visually check other parameters every time the temperature is checked and recorded. If operating close to the starting values, one need not record these parameters. If these values have changed much from the starting values, then record them.
23. Run test for 9 hours ± 10 minutes. Record start time when pump turned on and end time when pump turned off.

F. At end of the test (with pumps still operating):

24. Collect water samples in 300-mL glass bottles (the third bottle prepared for each experiment) to measure alkalinity, hardness and zeta potential.
25. Record system operating parameters: pressures, temperatures and flows.
26. Measure and record pH.
27. Set water samples to cool to room temperature.

G. After test is completed (pumps shut off):

28. Close tubing clamps and valves in bypass lines.
29. Remove filter and residue from white filter holder and place in plastic petri dish. Check upper portion of filter holder for retained solid residue. If present, remove upper half of filter holder. Put filter (in petri dish – opened to air) and filter holder (if it has residue in it) in dessicator in environmental lab for 24 hours or until dry. Place or identify parts from each system (1 or 2) so that they can be distinguished from one another.
30. Check blue filter holder for solid residue. If there is no noticeable solid residue, or only a minimal amount, rinse the filter in the sink in the Fluids Lab and let dry on a paper towel. If there is significant residue in the filter or filter holder, identify these parts and place in the dessicator for 24 hours or until dry.

31. Drain tanks. Wipe excess CaCO_3 from tank walls/bottom; from stirrer shaft and heater.
32. Close tank drains. Put in sufficient fresh water to cover lower pipe inlet by about 2 in.
33. Start pumps to circulate fresh water through system for about 5 minutes to flush clean, then drain.

TEST SYSTEM SAMPLING and MEASURING PROCEDURES
and SAMPLE PREPARATION
(MAGNETIC WATER TREATMENT)

1. Measure tank water temperature using the digital thermometer plugged into the T/C plug at start and end of each test and at about 2-hour intervals. Record temperatures on data sheet. Before recording temperature let the reading stabilize for 30–60 seconds after plugging in the T/C plug. Set the digital thermometer to “J” reading mode. (Do this by depressing the top [1st] and bottom [3rd] buttons simultaneously and holding for about 3 seconds while turning on the digital thermometer.)
2. Pressures and flow rates. Record on the data sheet only at the start (after pump starts) and end (just before pump is turned off) of each test. Visually verify correct, overall system operation every time the temperature is checked. If values are very different from their starting values then record these values on the data sheet. Use this to avoid filter plugging, blocked bypass lines or other unusual problems.
3. pH measurement. Check pH in both tanks at the start and end of each test and record on the data sheet. Use handheld pH meter. Place probe tip ½–2 inches below water surface. Wait until pH measurement stabilizes prior to recording the pH.
4. Water samples for alkalinity, hardness and zeta potential. A. Use one plastic sampler bottle in one water tank (always use the same sampler bottle for same test system). B. Using the bottle holder, quickly plunge the sampler bottle (with open mouth) about 6 inches below the water surface. C. Pour water into acid-rinsed, 300-mL, glass bottle. D. Sample from three locations within the tank: on each side of the suspended instrument rack (near the heater rod and near the stirrer shaft) and at the end of the suspended rack where there is the largest gap between the tank wall and the rack. E. Cap, label and set aside the glass bottles to cool while sampling for iron. F. For these samples taken at the end of the system tests, only ½ the sampler volumes need be taken. After sampling at all three locations in the tank, spill out about ½ of the sampler bottle contents. This yields about 150 mL total sample.
5. Water samples for iron (Fe). Steps A. – D. perform the same tasks as for the previously described water sampling. E. Add concentrated nitric acid (HNO₃) until the pH in the glass sample bottle falls just below 2 (usually requires 2–4 mL). Store sample at 4 ° C in walk-in refrigerated room in the Environmental Lab. F. Cap, label and set aside the glass bottles to cool to near room temperature while performing the titrations for alkalinity and hardness.
6. Titrations for alkalinity and hardness. A. When the sample water temperature drops to 74–86° F, begin titrations using the Hach test kits in the Fluids Lab. Use the “Low Range” instructions in the alkalinity test kit instructions to measure alkalinity. For hardness titrations use the Hach Company Manual “Digital Titrator Model 16900.” For calcium hardness, use Method 8204, page 101. For total hardness use Method 8213, page 109. B. Record the sample temperature measured just prior to pouring water into beaker or vial for titration. C. Record titration information on data sheet. NOTE: Swirl water in 300-mL bottle before pouring sample into titration container (small, square-cross section bottle - alkalinity, 250-

mL erlenmeyer flask – hardness). Swirl until any solid, undissolved particles on the bottom are suspended in the water, then pour sample into titration container.

7. Solid filter residue samples. A. Remove moist filter and solid residue from filter holders. Place in plastic petri dishes. If solid residue is building up in crevices of the filter holders, remove the appropriate parts of the filter holders. B. Label petri dishes. Keep filter housings associated with matching filters in petri dish (or label filter holder parts). C. Place all above components in dessicator for 24 hours or until dry. D. Cap all petri dishes to protect samples for use in XRD and XRF analyses.

8. Zeta Potential measurements. A. Get water to near room temperature before using the Zeta Meter. The walk-in refrigerated rooms in the Environmental Lab may be used to speed cooling. B. Verify that electrodes are relatively free of oxidation, or clean them. C. Warm up Zeta Meter for a few minutes prior to use. D. Measure and record sample water temperature. E. Swirl water sample in 300-mL bottle until any solid, undissolved particles on the bottom are suspended in the bulk fluid. Then pour water into Zeta Meter sample holder. E. Install electrodes. F. Install and position sample holder under Zeta Meter microscope. G. Measure and record conductivity. Using conductivity, use the table in the Zeta Meter manual to select the applied voltage to use. H. Track 20–30 particles on the 6.3x scale (in view of microscope eyepiece), using the “Full Scale” setting, stop. Set control knob on left to “standby,” record the number of particles tracked, and the average and standard deviation of the zeta potential (mV). I. Remove the sample holder, empty out the water, rinse the holder with deionized or distilled water, measure and record the sample water temperature, swirl the 300-mL sample bottle to suspend solid particles and then refill the sample holder. J. Without clearing the counter numbers, continue to track particles until 50 are reached (instrument beeps when 50 counts are reached).

9. Labeling of samples. A. Labels on bottles for water samples should include: test sampling date, approximate time (military), test system number (1 or 2), sample type (Iron-“Fe” or “alk., hard., z. pot.”), other pertinent information such as “acid rinsed” or “preserved, pH ≤ 2”. B. Labels on petri dishes with solid residue should include: test sampling date, approximate time and test system number.

10. Preparation of aqueous sample bottles. A. Sample bottles for alkalinity, hardness and zeta potential samples are to be washed with tap water and soap, then triple rinsed with deionized water. Allow to dry, upside down, then cap with glass stopper until use. B. Bottles for water samples for FAA iron analysis are to be well washed with tap water and soap, triple rinsed with deionized water, then well rinsed multiple times, with concentrated hydrochloric acid (HCl). Then rinse again with deionized water and suspend on rack for drying. Cap bottles with glass stoppers when dry.

11. Grinding of solid filter residue for XRD, XRF. Using the Micronizing grinder (Geology Dept.) grind the filter residue for three to four minutes. Use isopropyl alcohol as a grinding buffer and rinsing agent to carry the ground residue as detailed in Section 5.5.5 of the Thesis. Evaporate under hood on heater plate until dry.

12. Sample packing for XRD and XRF. A. Pack powder in circular depression of metal sample holders for the XRD batch run fixture until well packed. Surface should be smooth and even with top wall surface of sample holder. B. Weigh out 0.505–0.515 grams of residue and place in plastic petri dish. This amount of powdered residue is loosely placed in each XRF sample holders.

13. XRF operational parameters. A. Perform scans for a two-theta angular range to include peaks for iron, strontium and zinc utilizing a lithium fluoride (LiF) 200 crystal for the X-ray window. B. After scans are complete, use the following plotting routines on-screen to evaluate the peaks: “Overline” comparisons for quick comparisons of several traces at once. “Match” to select specific elements to match against the peaks. “Identify,” using the cursor, to identify individual peak heights. These peak heights are recorded manually as there is no known, available printer currently capable of printing from this computer routine at BYU. It is an old computer routine that was “hard” programmed to print on a specific printer (part of the system hardware) that no longer functions.

APPENDIX C

TABULATED ANALYTICAL DATA

TABLES

IX - ZETA POTENTIAL RESULTS FOR SYSTEM TESTS

X - IRON IN WATER SAMPLES BY FAA

XI - IRON CONTENT IN FILTER RESIDUE BY XRF

XII - XRD PEAK AREAS – SYSTEM TEST SAMPLES

TABLE IX Zeta Potential Results For System Tests

System Test date	System number	Number MTDs installed	Start or End of Test	Corrected to 25 C			Measured			Temp. correction factor Ct	Zeta Potential corrected to: 22.5 C (mv) Comments
				Specific Conductivity micromhos/cm	Voltage used (V)	Zeta Potential ave.(mV)	Zeta Potential dev.(mV)	Pot.-std. dev.(mV)	sample temp (F)		
12/1/98	1	3	start	317	300	-20.4	5.06	77	0.96	-19.6	
12/1/98	2	3	start	326	300	-21.4	5.21	75.75	0.96	-20.6 ave. of 2 samples	
12/1/98	1	3	end	286	300	-20.3	4.03	77.5	0.97	-19.7	
12/1/98	2	3	end	317	200	-19.5	3.98	76	0.97	-18.9	
12/3/98	1	1	start	346	200	-17.7	3.78	76	0.97	-17.2	
12/3/98	2	1	start	357	200	-15.6	3.08	76	0.97	-15.1	
12/3/98	1	1	end	304	300	-18.3	2.76	76	0.97	-17.8	
12/3/98	2	1	end	339	200	-18.7	3.76	76	0.97	-18.1	
12/5/98	1	6	start	353	200	-17.7	5.22	76	0.97	-17.2	
12/5/98	2	0	start	350	200	-19.1	4.87	76	0.97	-18.5	
12/5/98	1	6	end	294	300	-19.6	7.19	77	0.96	-18.8 ave. of 2 samples	
12/5/98	2	0	end	338	300	-22.1	8.87	76	0.97	-21.4	
12/8/98	1	3	start	338	200	-16.9	4.09	75.3	0.97	-16.4	
12/8/98	2	1	start	333	200	-17.1	6.06	75	0.97	-16.6	
12/8/98	1	3	end	296	300	-19.5	5.97	76.5	0.96	-18.7	
12/8/98	2	1	end	311	200	-17.9	4.22	76.5	0.96	-17.2	
12/10/98	1	1	start	325	200	-18.1	4.91	75	0.97	-17.6	
12/10/98	2	3	start	338	200	-16.9	3.8	75.5	0.97	-16.4	
12/10/98	1	1	end	285	300	-19.0	5	76	0.97	-18.4	
12/10/98	2	3	end	308	200	-21.4	4.84	76	0.97	-20.8	
12/12/98	1	0	start	338	200	-19.7	12.49	76	0.97	-19.1	
12/12/98	2	6	start	325	200	-14.0	3.97	76	0.97	-13.6	
12/12/98	1	0	end	293	300	-16.0	3.95	75.5	0.97	-15.5	
12/12/98	2	6	end	329	200	-18.4	5.19	75	0.97	-17.8	
12/17/98	1	6	start	347	200	-17.0	4.12	75	0.97	-16.5	
12/17/98	2	0	start	342	200	-17.8	4.66	75.5	0.97	-17.3	
12/17/98	1	6	end	296	300	-20.3	4.5	74	0.99	-20.1	
12/17/98	2	0	end	321	200	-22.8	5.97	75.5	0.97	-22.1	

TABLE IX Zeta Potential Results For System Tests (cont.)

System Test date	Sys. No.	# of Mag-nets	Start or End of Test	Corrected to 25 C		Measured		Zeta Pot. dev.(mV)	Zeta sample temp. (F)	Temp. correction factor Ct	Zeta Potential corrected to: 22.5 C (mv)	Comments
				Specific Conductivity micromhos/cm	Voltage (V) used	Zeta Potent. ave.(mV)	Zeta Pot.-std.					
12/19/98	1	0	start	351	200	-17.8	3.56	74	0.99	-17.6		
12/19/98	2	6	start	352	200	-19.6	4.84	74	0.99	-19.4		
12/19/98	1	0	end	286	300	-18.4	5.19	75	0.97	-17.8		
12/19/98	2	6	end	320	200	-25.5	8.25	75	0.97	-24.7		
12/30/98	1	0	start	307	200	-18.8	5.16	73.5	0.99	-18.6		
12/30/98	2	3	start	314	200	-15.9	3.81	74.5	0.97	-15.4		
12/30/98	1	0	end	291	200	-20.5	5.37	77	0.96	-19.7		
12/30/98	2	3	end	289	300	-16.5	4.66	74.5	0.97	-16.0		

NOTES:

- 1) The 6x scale was used on the ocular (eyepiece) scale.
- 2) K factor tested at 66-67 at start of December
- 3) Tracking time for good results should be > or = 2.5 sec
- 4) Water source for all these tests was the hose in the fluids lab.
- 5) Zeta potential corrected to 22.5 degree C
- 6) Ct= temperature correction factor interpolated from Zeta-Meter manual.
- 8) Particle counts are 50 unless otherwise noted.

TABLE X Total Iron in Water Samples by Flame Atomic Absorption

Test date	Sys-tem No.	No. of MTDs	Unconcentrated Samples			Concentrated Samples - Raw Data			Concentrated Samples - Calculated***	
			Sample ID	Total Fe (ppm)	(ppm)Std. Deviation	Sample ID	Total Fe (ppm)	(ppm)Std. Deviation	Concentration Factor	Total Fe(ppm)
12/1/98	1	3	AU	0.1	0.049	AC	2.03	0.037	29.8	0.068
12/1/98	2	3	BU	0.08	0.032	BC	1.06	0.026	20.8	0.051
12/3/98	1	1	CU	0.06	0.038	CC	2.63	0.042	98.6	0.027
12/3/98	2	1	DU	0.1	0.044	DC	-	-	-	-
12/5/98	1	6	EU	0.05	0.029	EC	0.59	0.031	23.1	0.026
12/5/98	2	0	FU	0.06	0.045	FC	2.35	0.319	95.3	0.025
12/8/98	1	3	GU	0.03	0.031	GC	0.54	0.029	19.7	0.027
12/8/98	2	1	HU	0.05	0.028	HC	0.68	0.033	26.6	0.026
12/10/98	1	1	IU	1.77**	0.034	IC	0.66	0.034	17.1	0.039
12/10/98	2	3	JU	0.07	0.034	JC	0.55	0.040	22.2	0.025
12/12/98	1	0	KU	0.04	0.038	KC	1.26	0.028	17.4	0.072
12/12/98	2	6	LU	0.03	0.037	LC	0.41	0.044	22.1	0.019
12/17/98	1	6	MU	0.06	0.022	MC	-	-	-	-
12/17/98	2	0	NU	0.03	0.038	NC	-	-	-	-
12/19/98	1	0	OU	<0.025	0.058	OC	-	-	-	-
12/19/98	2	6	PU	0.05	0.043	PC	0.53	0.031	25.9	0.02
12/30/98	1	0	QU	0.05	0.036	QC	-	-	-	-
12/30/98	2	3	RU	<0.025	0.035	RC	-	-	-	-
1/19/99	*	*	SU	0.11	0.039	SC	2.22	0.034	17.1	0.13

Notes: Flame Atomic Absorption (FAA) Method Detection Limit (MDL) = 0.025 ppm iron.

Concentrations < 0.03 ppm reported as below MDL (<0.025)

* = tap water. FAA method sample blank was not run through the test system.

- = Insufficient aqueous sample remaining after concentration procedure for FAA analysis.

** = FAA analyst suspected a mislabelling since this sample measured so far out of range.

*** = Calculated Total Fe = (Raw Data Total Fe / concentration factor).

Average ratio of concentrated to unconcentrated Total Fe for 12 samples = .043/.061 = .70

FAA analysis done at Provo Water Resources Laboratory by Michael Scheetz 1/23/99.

TABLE XI Iron Content in Filter Residue Samples by XRF

Data File Name	System Test Date	System Number	No. of MTD's Installed	Counts = Relative Concentration K alpha 1 Peak Height (kcps)		
				Fe	Sr	Zn
LAM 12-A	12/8/98	2	1	0.355	2.381	1.317
LAM 12-B	12/12/98	2	6	0.318	2.272	0.855
LAM 12-C	12/19/98	2	6	0.29	2.057	2.13
LAM 12-D	12/17/98	2	0	0.396	2.228	2.154
LAM 12-E	12/8/98	1	3	0.535	1.386	1.045
LAM 12-F	12/10/98	2	3	0.332	2.063	1.375
LAM 12-G	12/10/98	1	1	0.358	2.096	0.818
LAM 12-H	12/19/98	1	0	0.31	1.67	1.049
LAM 12-I	12/30/98	1	0	0.315	2.035	1.235
LAM 12-J	12/30/98	2	3	0.444	2.119	1.823
LAM 12-L	12/5/98	2	0	0.478	1.939	2.443
LAM 12-M	12/12/98	1	0	0.317	1.706	1.097
LAM 12-N	12/1/98	2	3	0.541	1.363	2.444
LAM 12-O	12/3/98	1	1	0.435	1.403	1.451
LAM 12-P	12/3/98	2	1	0.663	1.277	0.909
LAM 12-Q	12/17/98	1	6	0.295	1.772	1.009
LAM 12-R	12/5/98	1	6	0.341	1.461	1.534
LAM 12-S	12/1/98	1	3	0.436	2.062	2.193

TABLE XII XRD Peak Areas (cpm) - December, 1998 System Test Samples

2-Theta-->	approximate 2-theta angle and corresponding calcite or aragonite peak no.												% estimated calcite	System test date	System number	Number MTDs installed	
	29.4	39.4	43.2	47.5	26.2	45.9	27.2	33.1	a1	a2	a3	a4					
File name	c1	c2	c3	c4	a1	a2	a3	a4									
kl1211a.ni	9377	1915	1781	2287	204	187	123	0						97%	12/1/98	1	3
kl1212a.ni	13599	1951	2378	2463	0	0	0	0						100%	12/1/98	2	3
kl1231a.ni	13708	2168	1745	2831	147	78	0	0						99%	12/3/98	1	1
kl1232a.ni	14186	2091	2053	2857	90	0	0	0						100%	12/3/98	2	1
kl1251a.ni	13746	2173	2360	2991	93	0	0	0						100%	12/5/98	1	6
kl1252a.ni	13305	1832	2020	2852	266	247	180	0						97%	12/5/98	2	0
kl1281a.ni	11936	1867	1909	2283	172	0	0	0						99%	12/8/98	1	3
kl1282a.ni	12803	1797	1917	2696	350	308	170	0						96%	12/8/98	2	1
kl12101a.ni	10289	1645	1674	2717	195	270	113	0						97%	12/10/98	1	1
kl12102a.ni	12213	1843	1822	2520	315	235	162	0						96%	12/10/98	2	3
kl12121a.ni	13575	2161	1910	2864	150	110	74	0						98%	12/12/98	1	0
kl12122a.ni	12941	2091	1960	2647	443	319	239	0						95%	12/12/98	2	6
kl12171b.ni	13543	2112	1848	2791	0	122	0	0						99%	12/17/98	1	6
kl12172b.ni	12359	1987	1813	2767	361	282	235	0						96%	12/17/98	2	0
kl12191b.ni	13384	1883	1844	2864	180	139	129	0						98%	12/19/98	1	0
kl12192b.ni	12558	1812	1926	2394	209	207	0	0						98%	12/19/98	2	6
kl12301b.ni	12650	1904	1989	2580	285	213	0	0						97%	12/30/98	1	0
kl12302b.ni	12771	1961	1789	2441	276	237	197	0						96%	12/30/98	2	3
klmalin.ni*	13946	2002	1997	2783	0	0	0	0						100%	NA	NA	NA
klaldric.ni**	14430	2409	2207	3020	0	0	0	0						100%	NA	NA	NA

Notes: NA = not applicable

c1-c4 & a1-a4 are the 4 most prominent calcite and aragonite peaks respectively; 2-theta is the angle between source & detector

* = Mallinckrodt, calcium carbonate chelometric standard used in Thesis research

** = Aldrich, calcium carbonate chelometric standard used in Dec. 1998 system tests

APPENDIX D

XRD PEAK PLOTS FOR CALCIUM CARBONATE CRYSTAL PHASE

NOTE: The system test samples for these plots may be identified by matching the file name "FN" (in the upper left corner of the page when held in landscape format) with the "File name" in Table XII of Appendix C. Table XII then lists all appropriate system test parameters and dates for each data file.

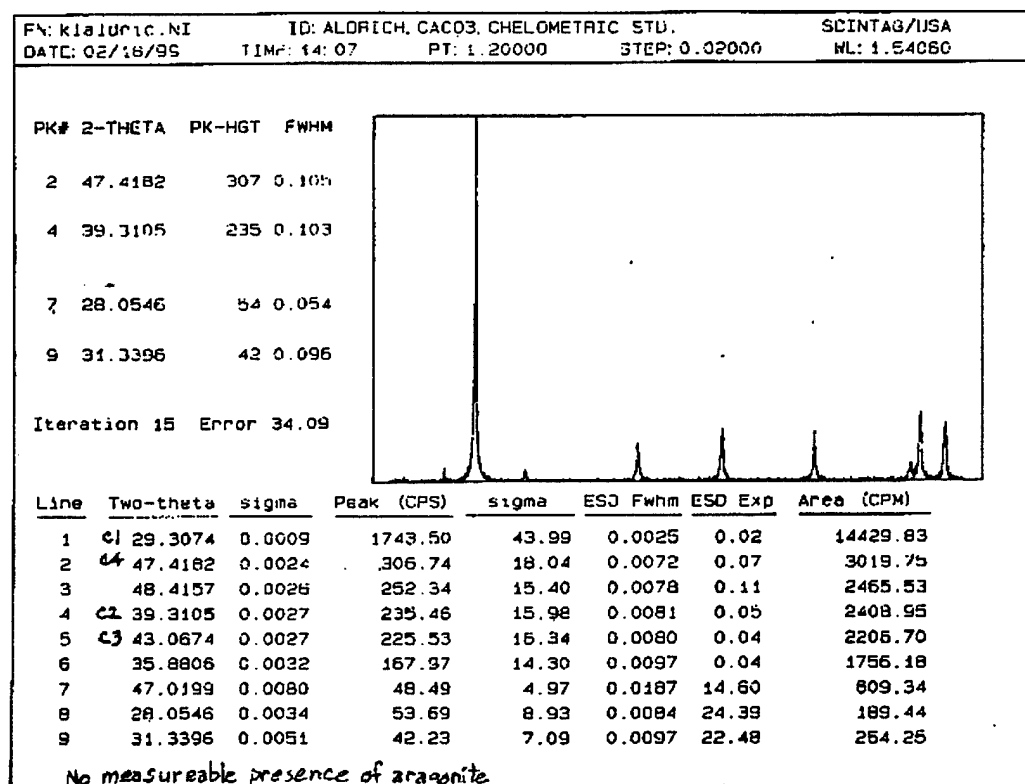
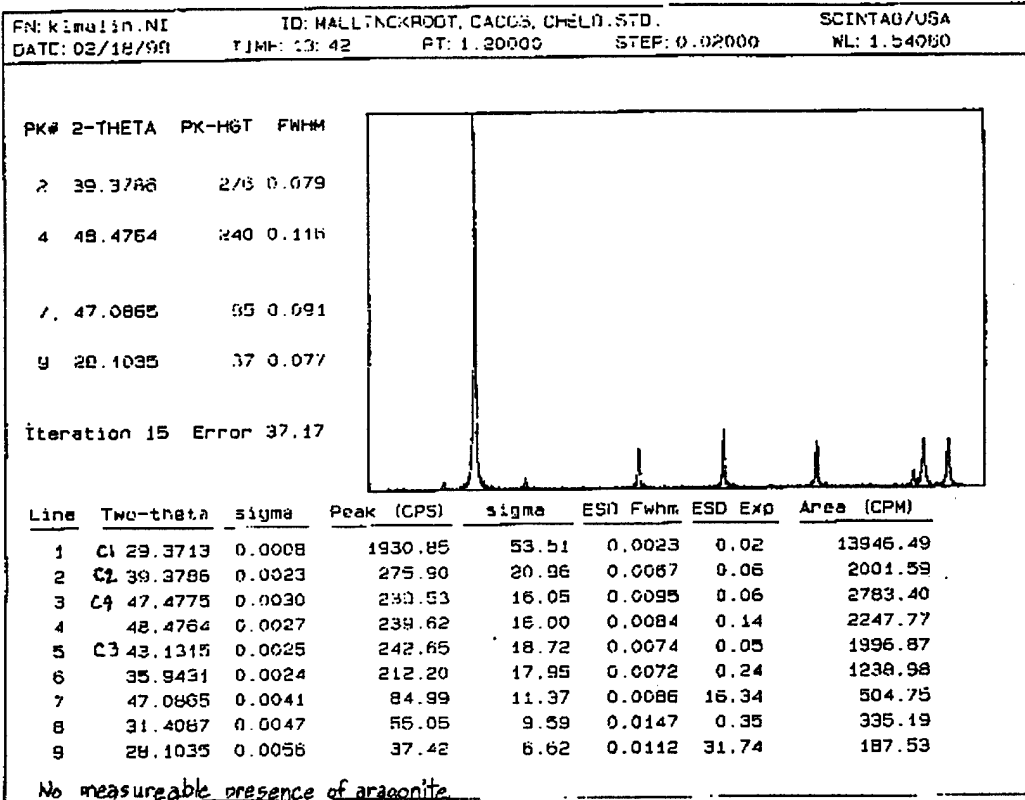

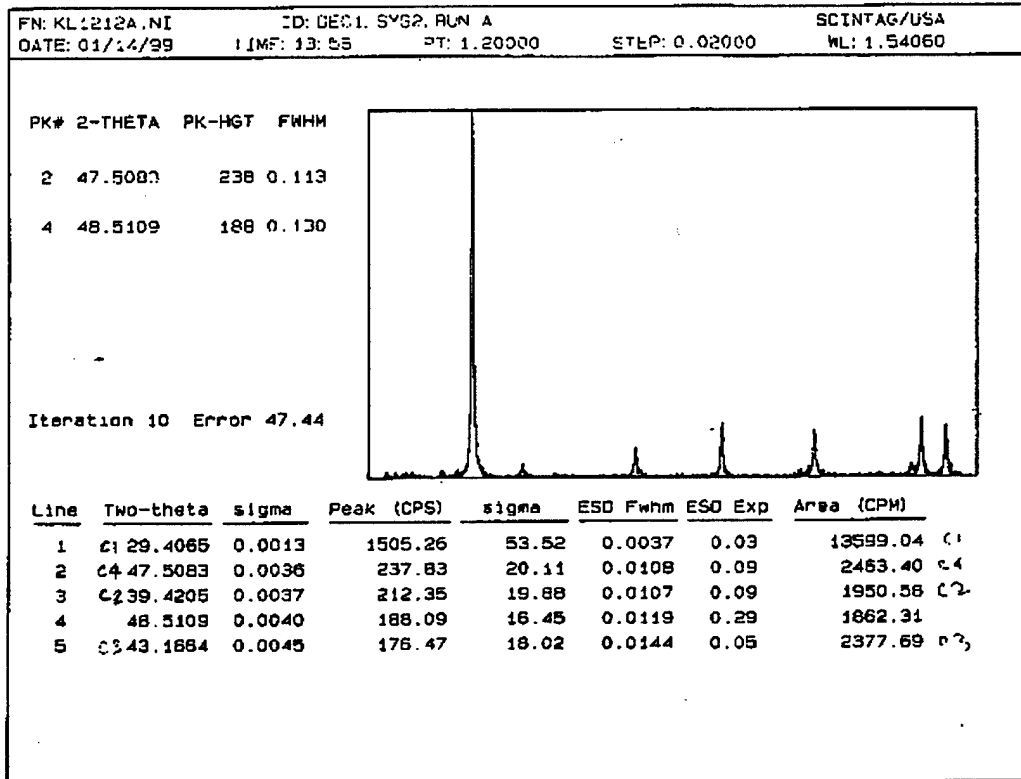
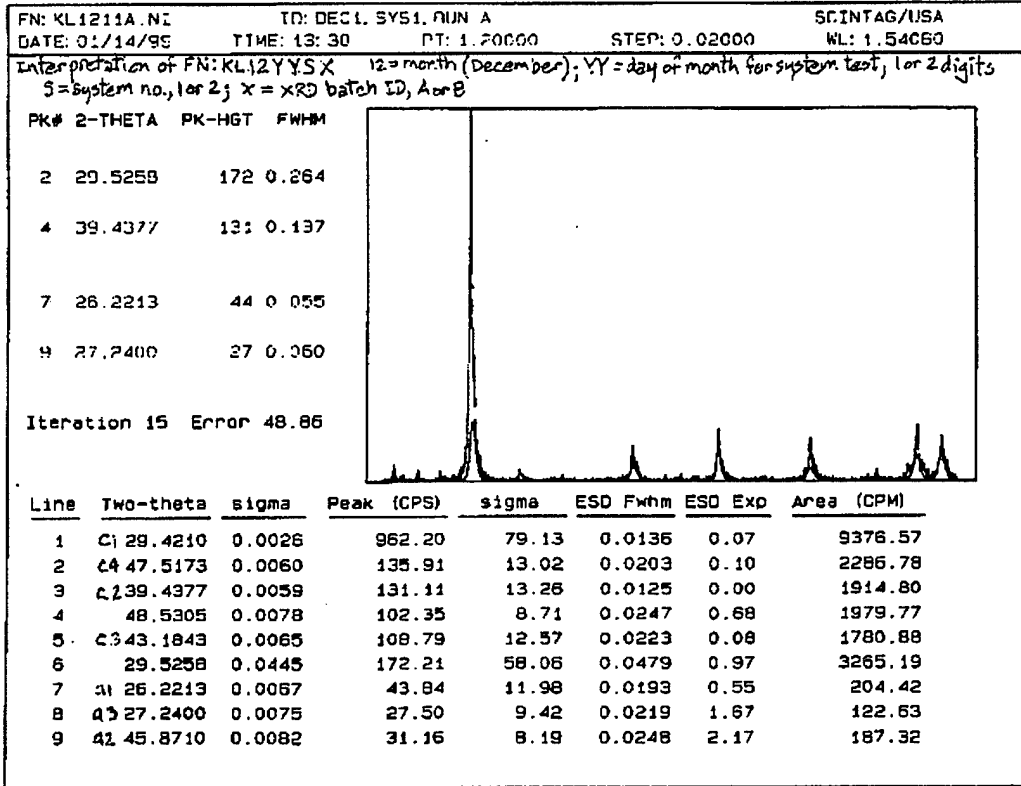

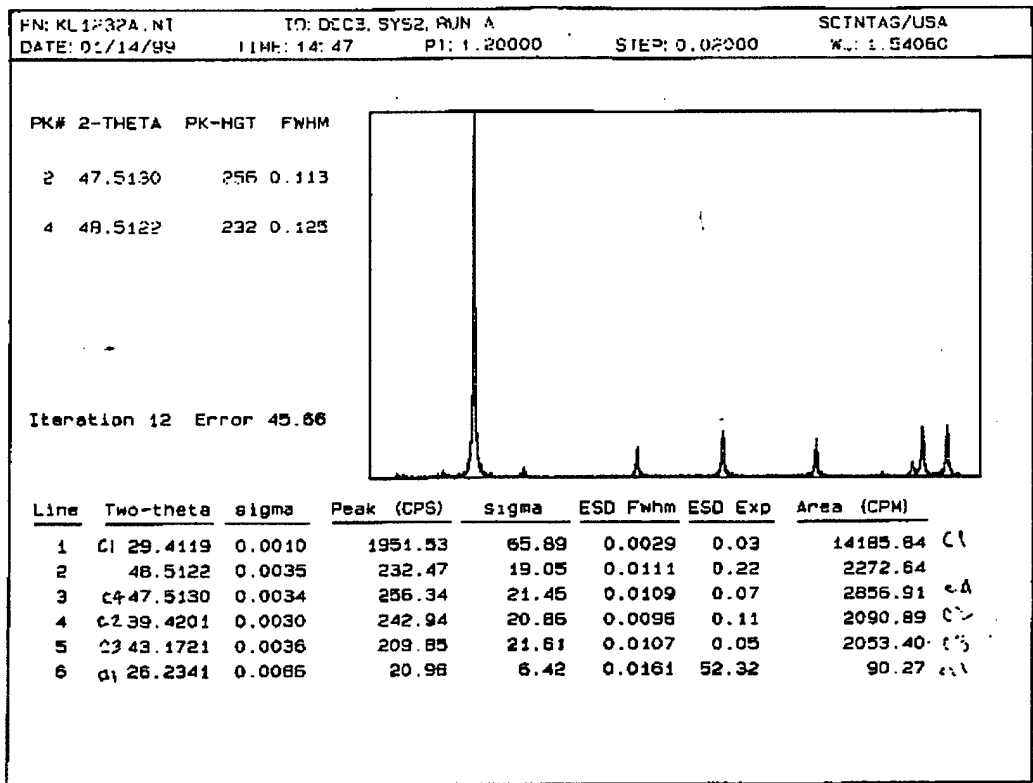
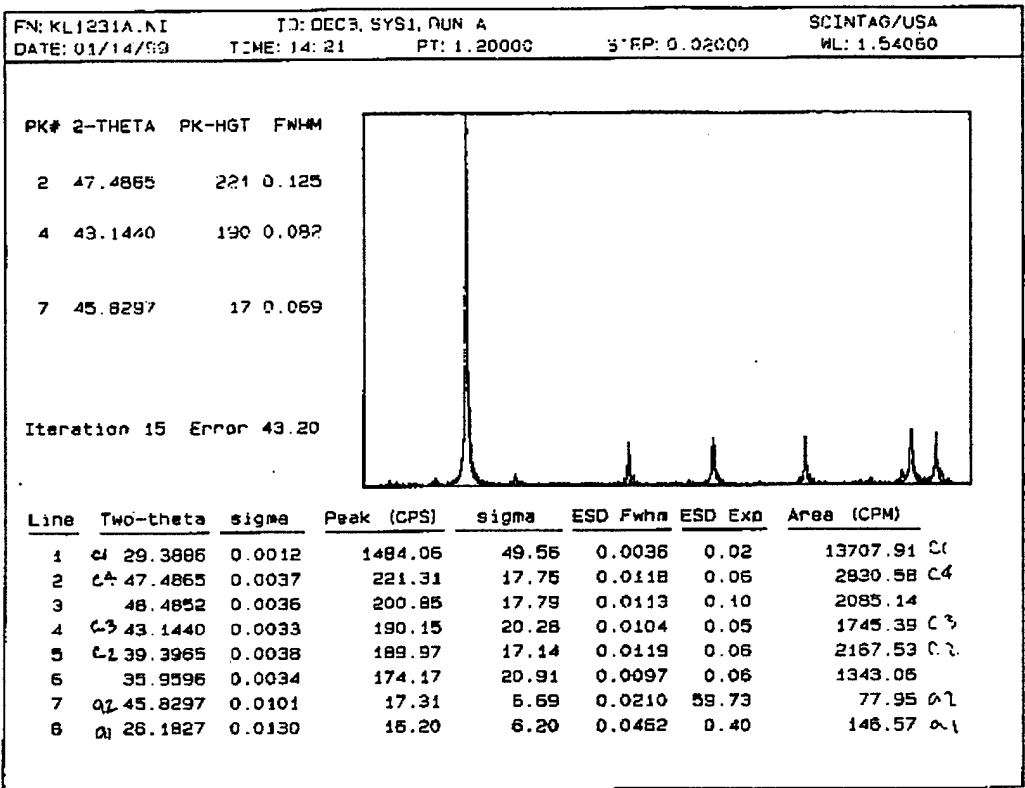

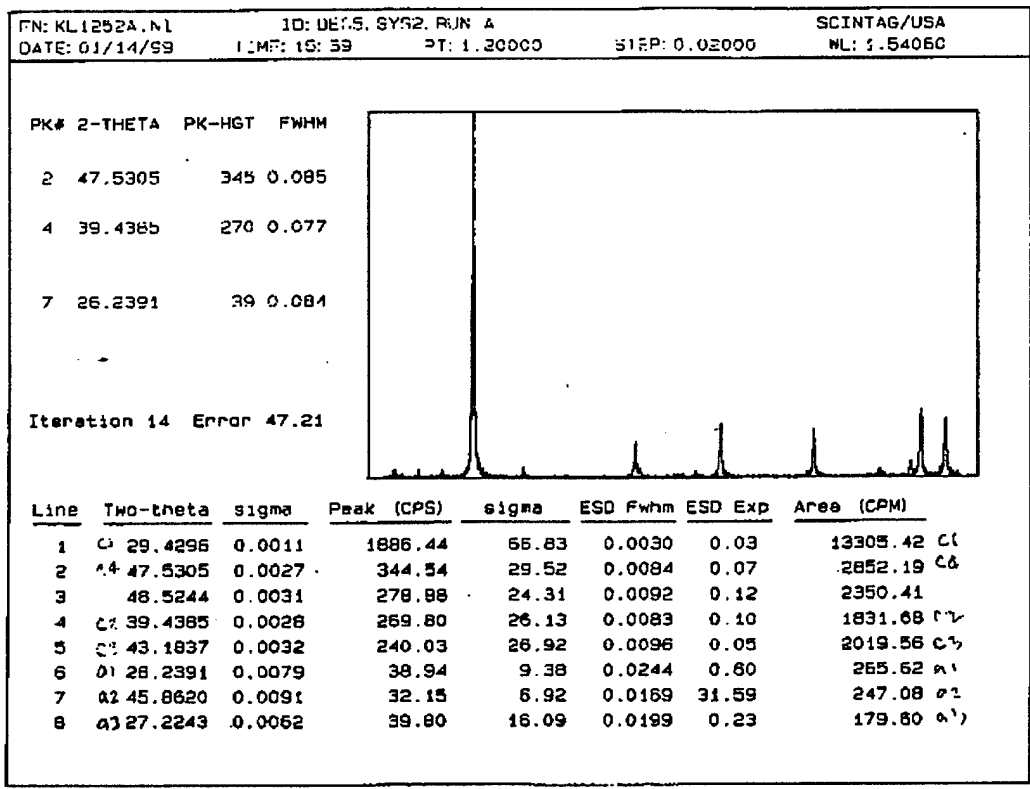
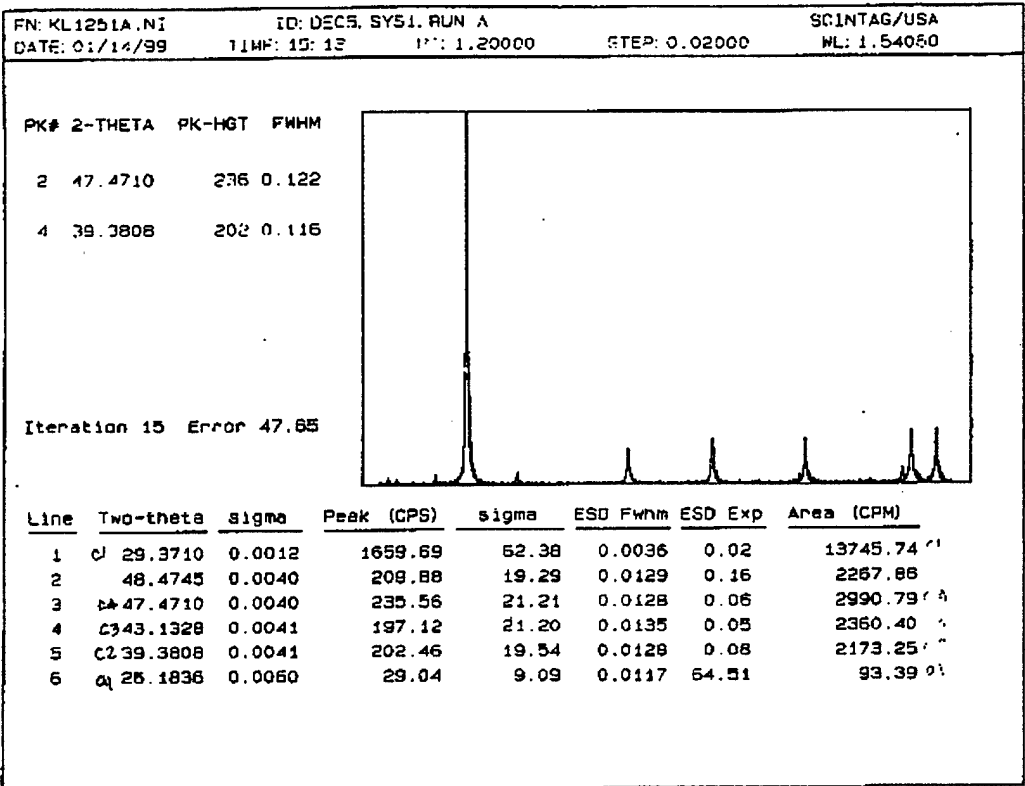

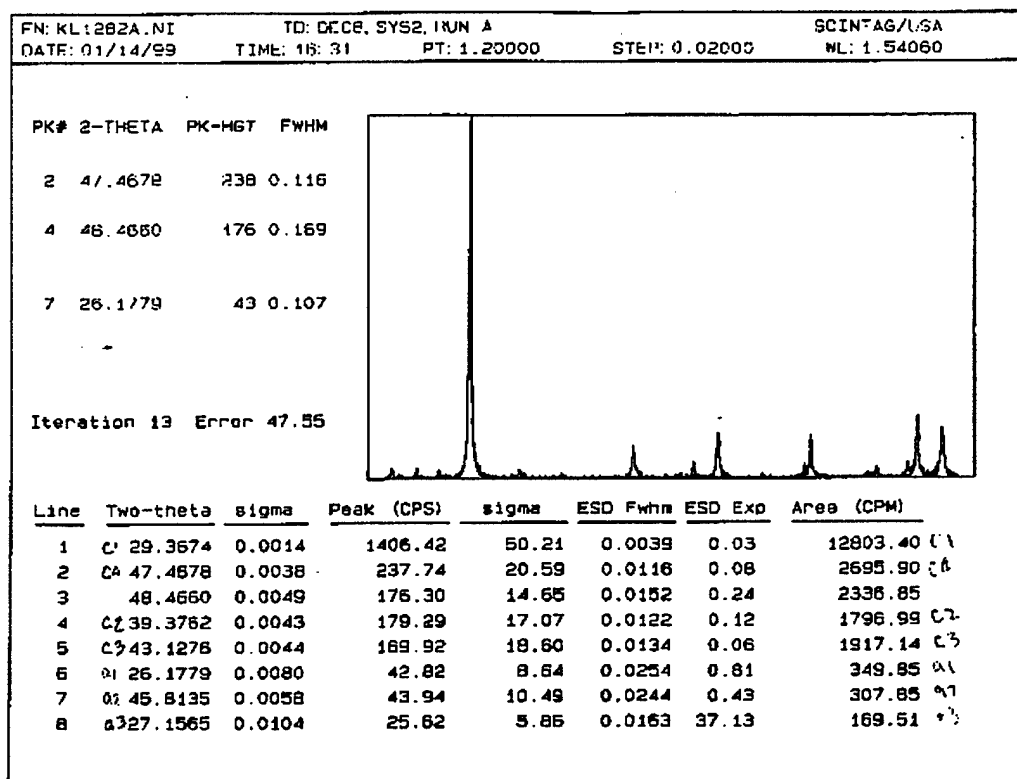
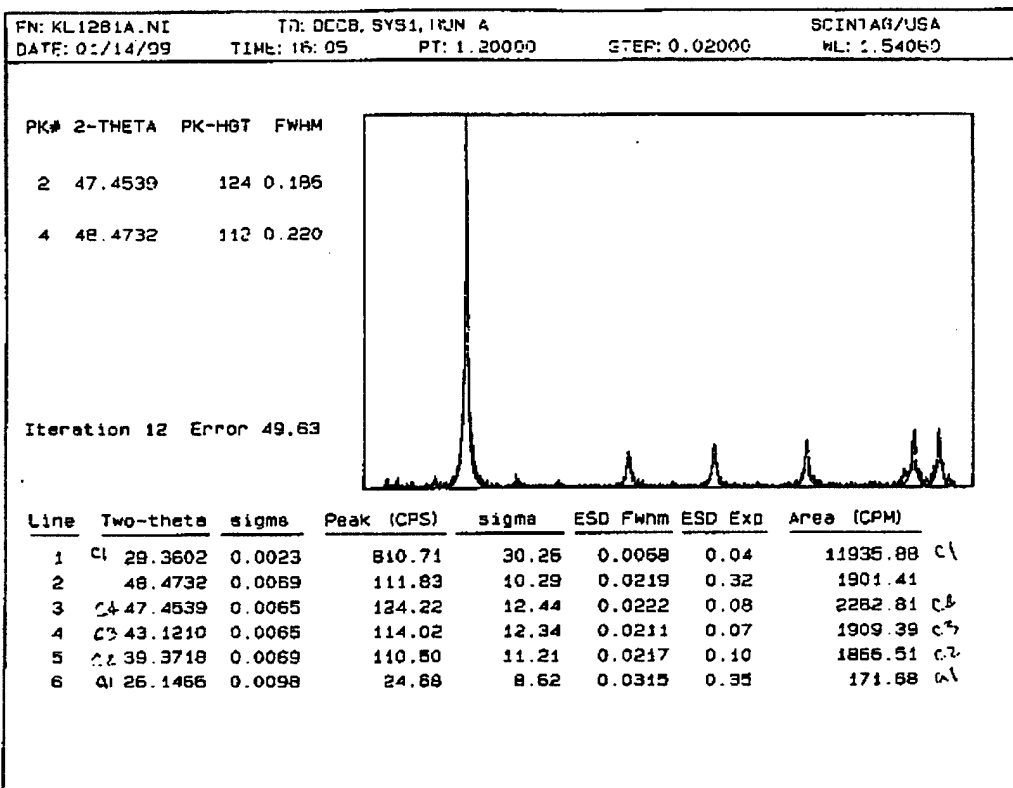

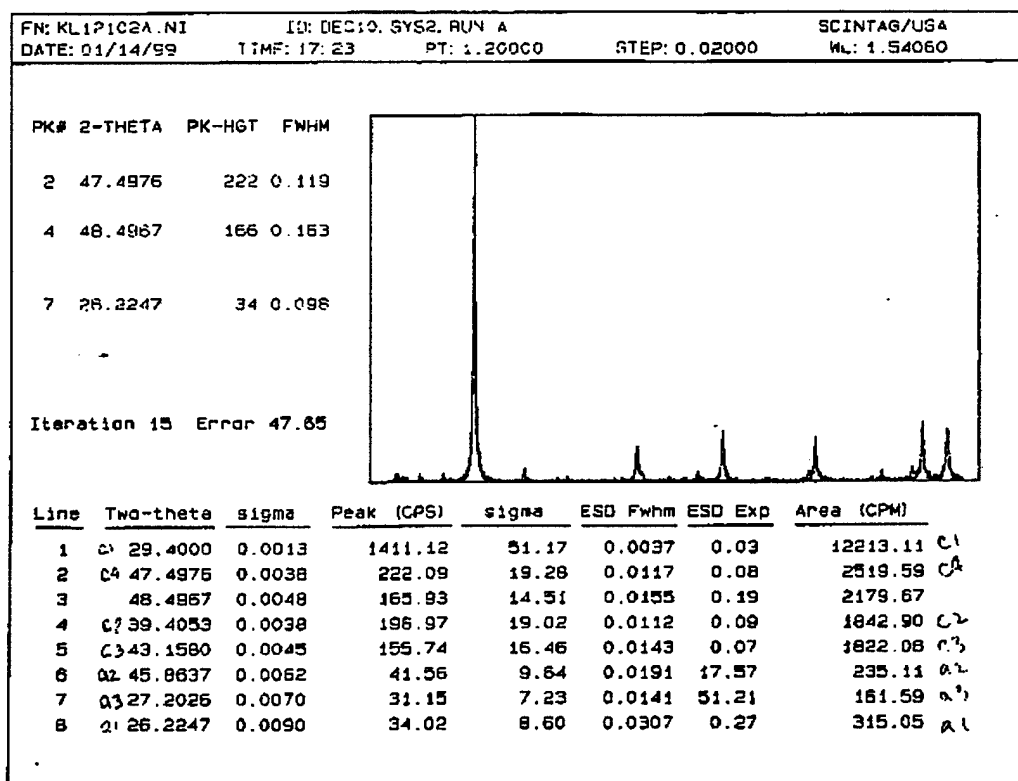
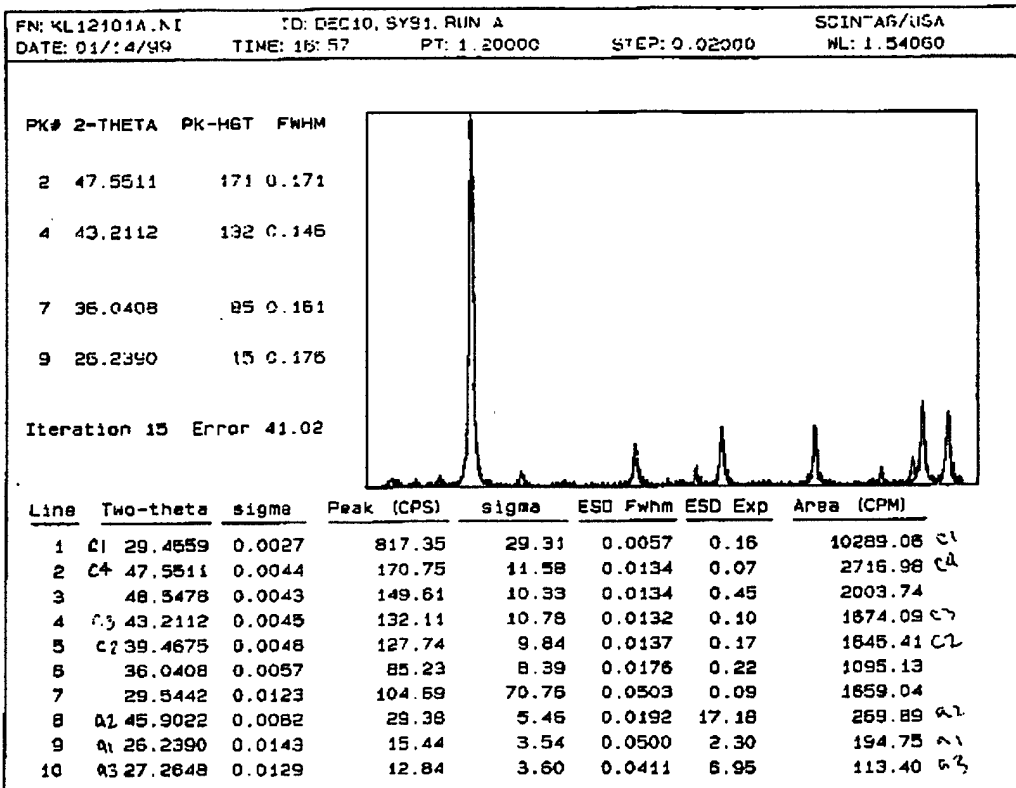

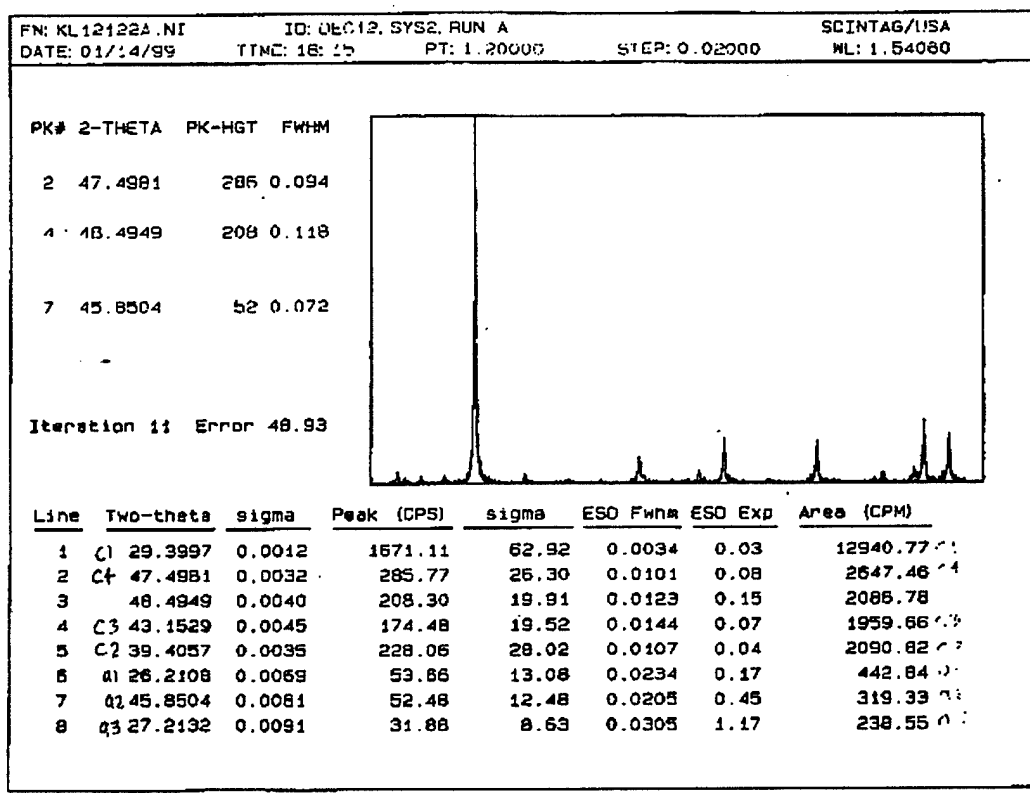
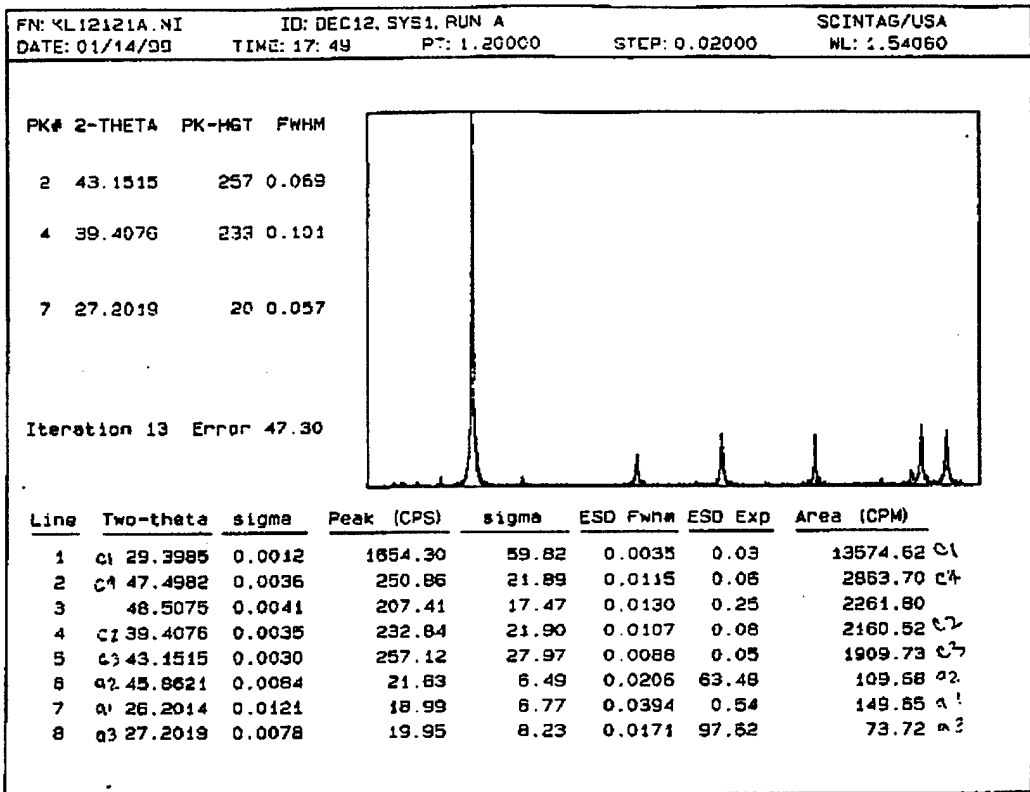

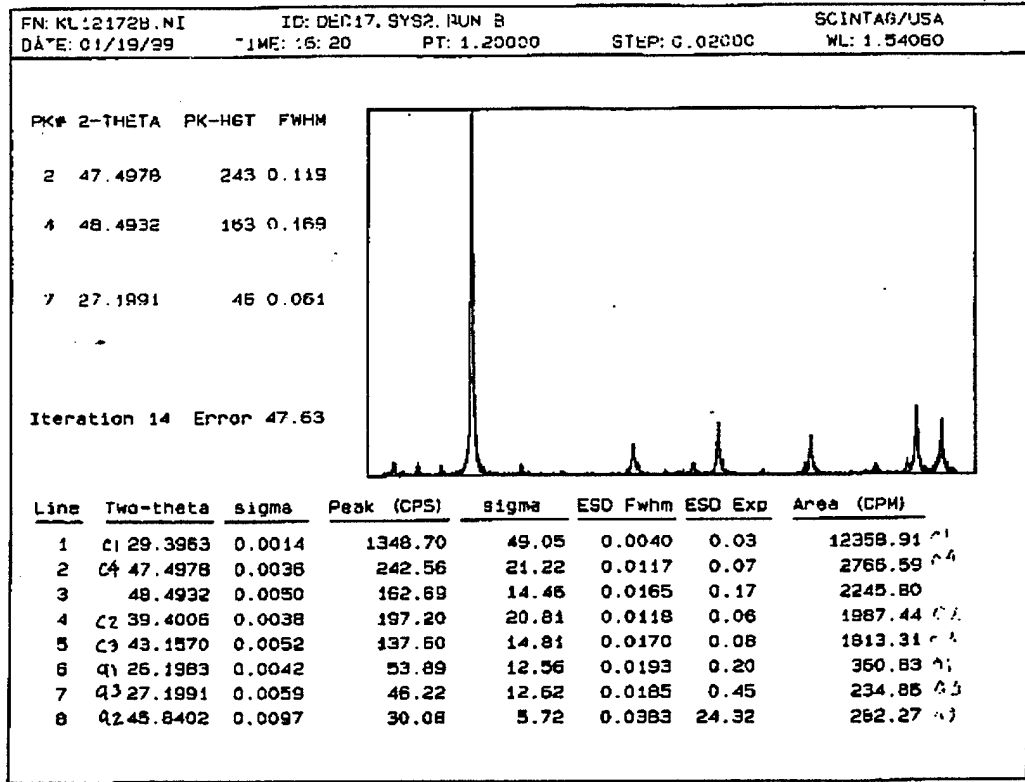
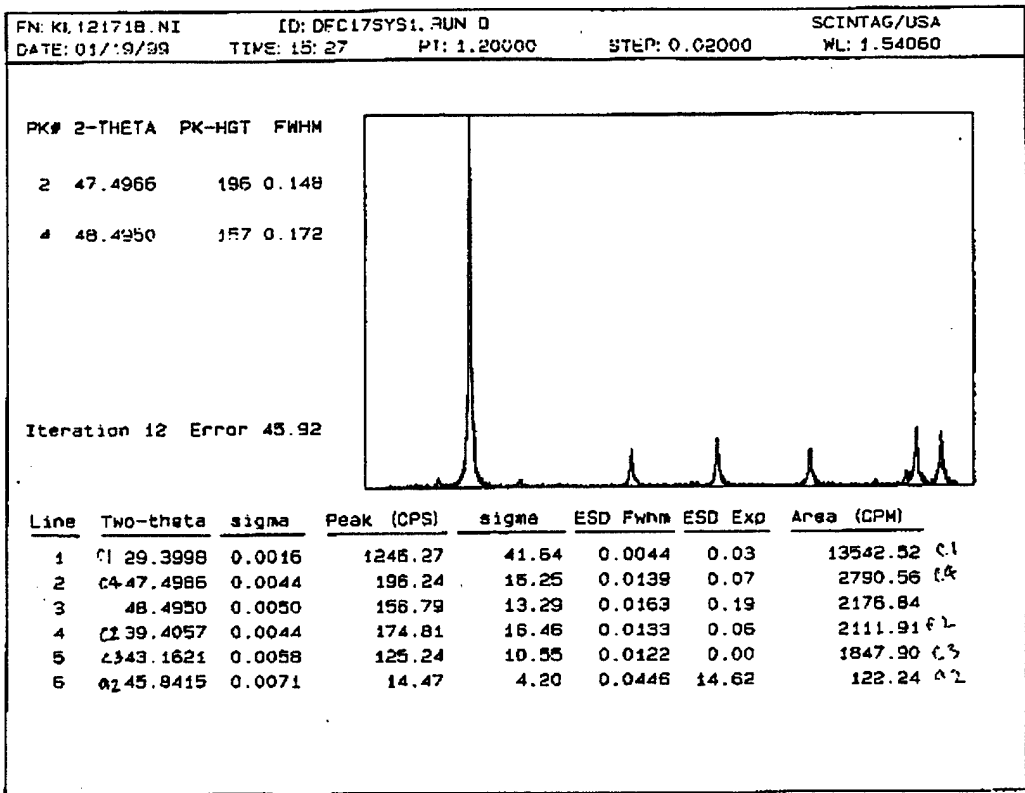

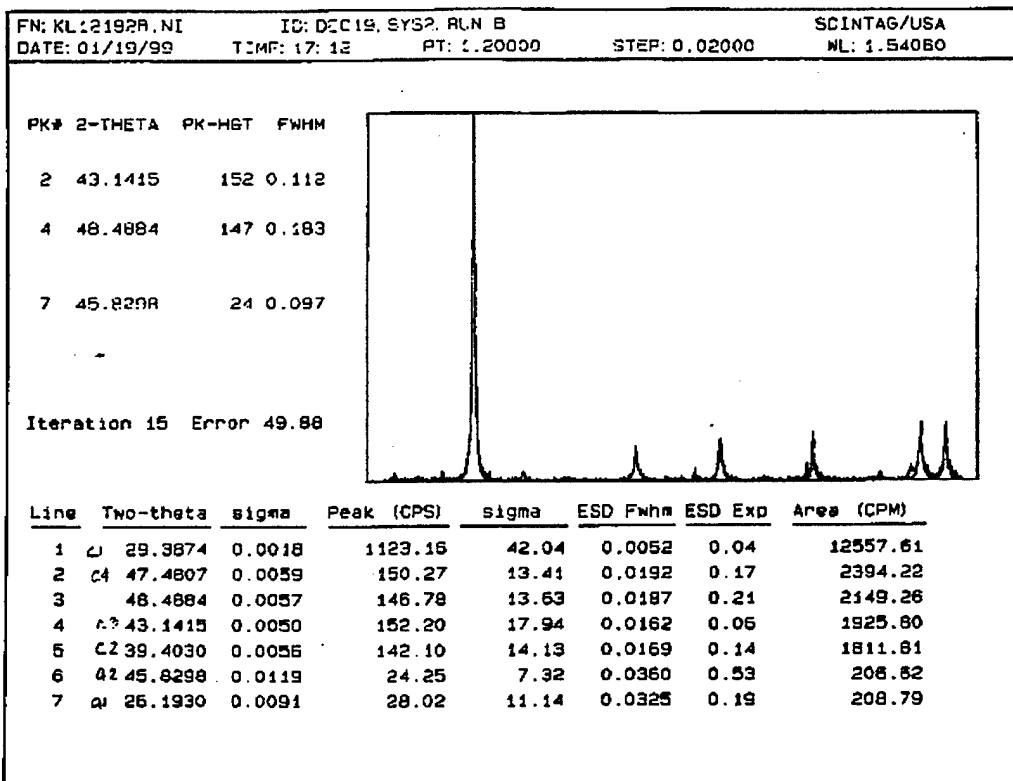
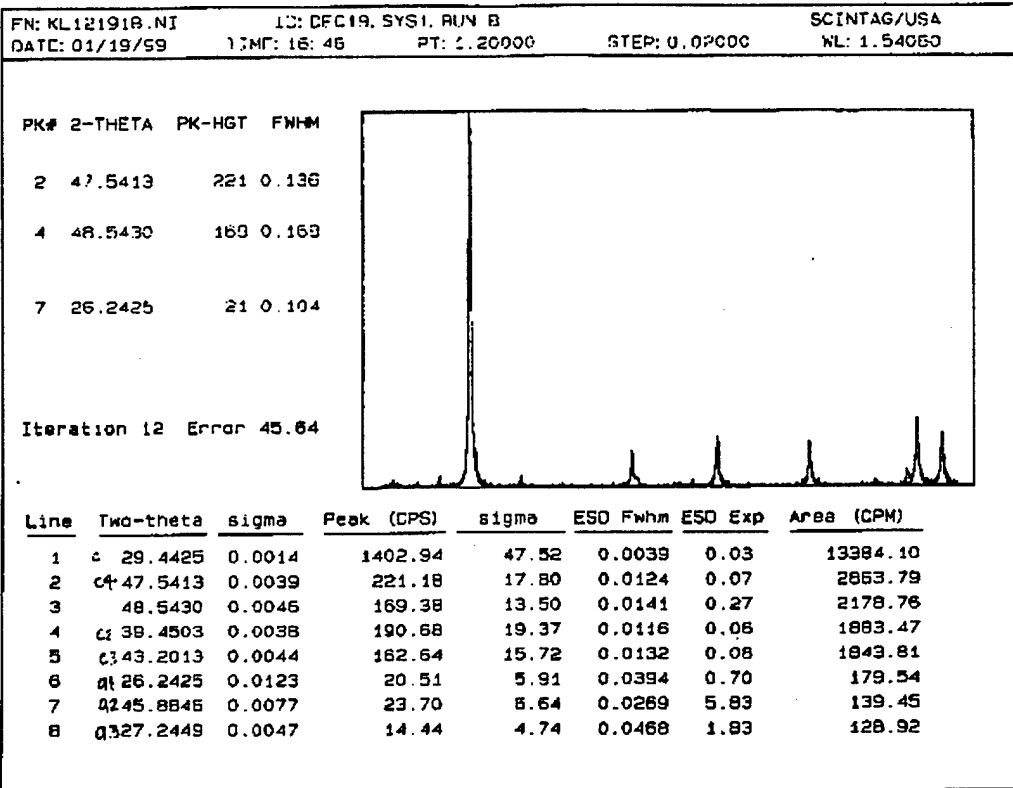

FN: KL123018.NI IJ: DFC30.SYS1.RUN 6 SCINTAG/USA
 DATE: 01/19/99 TIME: 17: 38 PT: 1.20000 STEP: 0.02000 WL: 1.54080

PK# 2-THETA PK-HGT FWHM
 2 47.4893 196 0.139
 4 46.4994 160 0.176
 7 26.2004 38 0.046



Iteration 11 Error 41.79

Line	Two-theta	sigma	Peak (CPS)	sigma	ESD Fwhm	ESD Exp	Area (CPM)
1	C1 29.3924	0.0014	1223.21	38.09	0.0040	0.03	12550.12
2	C4 47.4893	0.0038	195.97	15.06	0.0120	0.07	2580.41
3	48.4994	0.0045	159.76	11.74	0.0138	0.21	2177.88
4	C2 39.3972	0.0037	180.49	15.88	0.0112	0.07	1904.29
5	C3 43.1505	0.0042	156.90	14.27	0.0131	0.05	1989.46
6	35.9714	0.0052	113.26	11.47	0.0160	0.08	1448.53
7	Q2 45.8542	0.0084	38.91	9.45	0.0112	29.63	213.30
8	Q1 26.2004	0.0069	38.33	10.71	0.0178	0.10	285.19

FN: KL123028.NI IJ: DFC30.SYS2.RUN 6 SCINTAG/USA
 DATE: 01/19/99 TIME: 18: 04 PT: 1.20000 STEP: 0.02000 WL: 1.54080

PK# 2-THETA PK-HGT FWHM
 2 47.4894 188 0.160
 4 39.4045 165 0.193
 7 45.8360 37 0.093



Iteration 12 Error 48.16

Line	Two-theta	sigma	Peak (CPS)	sigma	ESD Fwhm	ESD Exp	Area (CPM)
1	C1 29.3896	0.0015	1368.69	49.89	0.0041	0.03	12770.96
2	48.4880	0.0053	159.90	13.82	0.0173	0.20	2317.87
3	C4 47.4894	0.0047	188.23	15.59	0.0148	0.16	2441.37
4	C2 39.4045	0.0048	165.37	16.12	0.0148	0.10	1960.53
5	C3 43.1451	0.0043	167.90	19.45	0.0132	0.06	1788.55
6	Q1 26.1952	0.0076	40.47	10.84	0.0230	0.26	278.29
7	Q2 45.8360	0.0077	35.75	8.77	0.0238	4.05	237.40
8	Q3 27.1931	0.0103	23.72	6.59	0.0415	26.18	197.16