

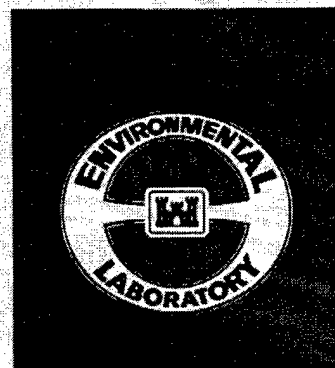

US Army Corps
of Engineers



**FIELD VERIFICATION PROGRAM
(UPLAND DISPOSAL)**

TECHNICAL REPORT D-88-7

**SYNTHESIS OF THE RESULTS OF THE FIELD
VERIFICATION PROGRAM UPLAND
DISPOSAL ALTERNATIVE**

by

Bobby L. Folsom, Jr., John G. Skogerboe, Michael R. Palermo
John W. Simmers, Stephen A. Pranger, Robert A. Shafer

Environmental Laboratory

DEPARTMENT OF THE ARMY
Waterways Experiment Station, Corps of Engineers
PO Box 631, Vicksburg, Mississippi 39181-0631

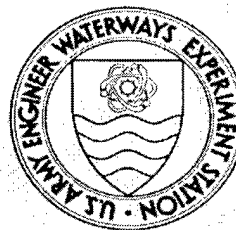

October 1988
Final Report

Approved For Public Release; Distribution Unlimited

19990618 184

Prepared for DEPARTMENT OF THE ARMY
US Army Corps of Engineers
Washington, DC 20314-1000

DTIC QUALITY INSPECTED 4

AQI 99-09-1642

**Destroy this report when no longer needed. Do not return
it to the originator.**

**The findings in this report are not to be construed as an official
Department of the Army position unless so designated
by other authorized documents.**

**The contents of this report are not to be used for
advertising, publication, or promotional purposes.
Citation of trade names does not constitute an
official endorsement or approval of the use of
such commercial products.**

**The D-series of reports includes publications of the
Environmental Effects of Dredging Programs:
Dredging Operations Technical Support
Long-Term Effects of Dredging Operations
Interagency Field Verification of Methodologies for
Evaluating Dredged Material Disposal Alternatives
(Field Verification Program)**

Unclassified
SECURITY CLASSIFICATION OF THIS PAGE

REPORT DOCUMENTATION PAGE				Form Approved OMB No. 0704-0188	
1a. REPORT SECURITY CLASSIFICATION Unclassified			1b. RESTRICTIVE MARKINGS		
2a. SECURITY CLASSIFICATION AUTHORITY		3. DISTRIBUTION / AVAILABILITY OF REPORT Approved for public release; distribution unlimited.			
2b. DECLASSIFICATION / DOWNGRADING SCHEDULE					
4. PERFORMING ORGANIZATION REPORT NUMBER(S) Technical Report D-88-7			5. MONITORING ORGANIZATION REPORT NUMBER(S)		
6a. NAME OF PERFORMING ORGANIZATION USAEWES Environmental Laboratory		6b. OFFICE SYMBOL (if applicable)	7a. NAME OF MONITORING ORGANIZATION		
6c. ADDRESS (City, State, and ZIP Code) PO Box 631 Vicksburg, MS 39181-0631			7b. ADDRESS (City, State, and ZIP Code)		
8a. NAME OF FUNDING / SPONSORING ORGANIZATION US Army Corps of Engineers		8b. OFFICE SYMBOL (if applicable)	9. PROCUREMENT INSTRUMENT IDENTIFICATION NUMBER		
8c. ADDRESS (City, State, and ZIP Code) Washington, DC 20314-1000			10. SOURCE OF FUNDING NUMBERS		
			PROGRAM ELEMENT NO.	PROJECT NO.	TASK NO.
10. SOURCE OF FUNDING NUMBERS WORK UNIT ACCESSION NO.					
11. TITLE (Include Security Classification) Synthesis of the Results of the Field Verification Program Upland Disposal Alternative					
12. PERSONAL AUTHOR(S) Folsom, B. L., Jr.; Skogerboe, J. G.; Palermo, M. R.; Simmers, J. W.; Pranger, S. A.; Shafer, R. A.					
13a. TYPE OF REPORT Final report		13b. TIME COVERED FROM _____ TO _____		14. DATE OF REPORT (Year, Month, Day) October 1988	15. PAGE COUNT 89
16. SUPPLEMENTARY NOTATION Available from National Technical Information Service, 5285 Port Royal Road, Springfield, VA 22161.					
17. COSATI CODES			18. SUBJECT TERMS (Continue on reverse if necessary and identify by block number)		
FIELD	GROUP	SUB-GROUP	Black Rock Harbor (BRH) Upland disposal		
			Contaminated dredged material		
			Field Verification Program (FVP)		
19. ABSTRACT (Continue on reverse if necessary and identify by block number)					
<p>Contaminated dredged material from the Black Rock Harbor (BRH) maintenance dredging project in the US Army Corps of Engineers New England Division was used to field verify: (a) procedures for predicting the quality of effluent discharged from the upland site during filling operations, (b) procedures for predicting the quality of upland surface runoff resulting from rainfall following disposal, (c) possible changes in ground-water quality following disposal, (d) procedures for predicting potential contaminant mobility into plants, and (e) procedures for predicting potential contaminant mobility into animals.</p> <p>The upland disposal site was constructed within a protected area using conventional construction techniques and was hydraulically filled from barges. The filling operation provided conditions typical of confined dredged material disposal operations. Following filling, a weir allowed free drainage of surface water (as with most disposal sites) as</p> <p style="text-align: right;">(Continued)</p>					
20. DISTRIBUTION / AVAILABILITY OF ABSTRACT <input checked="" type="checkbox"/> UNCLASSIFIED / UNLIMITED <input type="checkbox"/> SAME AS RPT. <input type="checkbox"/> DTIC USERS			21. ABSTRACT SECURITY CLASSIFICATION Unclassified		
22a. NAME OF RESPONSIBLE INDIVIDUAL			22b. TELEPHONE (Include Area Code)	22c. OFFICE SYMBOL	

19. ABSTRACT (Continued).

the fill stabilized through consolidation. Within approximately 9 months, the upland substrate had stabilized at the desired surface elevation.

The modified elutriate test adequately predicted the dissolved concentration of contaminants and the contaminant fractions of the total suspended solids (SS) in the effluent. Comparison of laboratory results with field data indicated that the modified elutriate test was a generally conservative predictor. The column settling analysis and corresponding prediction of effluent SS concentration compared favorably with field data and yielded a conservative estimate of the effluent SS. Dissolved oxygen levels showed marked increases due to turbulence, mixing, and atmospheric reaeration, confirming that oxidizing conditions were present in the disposal area ponded water. Total metal concentrations reflected a high removal due to sedimentation in the disposal area, with an average retention of 98.3 percent. Results for total phosphorus, total organic carbon, and polychlorinated biphenyl (PCB) removal were generally similar to those for metal removal. The US Environmental Protection Agency (USEPA) Maximum Water Quality Criteria for Protection of Aquatic Life were exceeded for copper, nickel, and PCBs.

Results of the surface runoff water quality test procedure conducted on composited, wet dredged material in the laboratory showed that contaminants would be poorly soluble and tightly bound to the particulates. However, when the wet dredged material was allowed to dry and oxidize, significant physicochemical changes occurred in the material that increased soluble contaminants in resulting runoff. Dissolved concentrations of cadmium, copper, nickel, zinc, and manganese in surface runoff from the dry, oxidized material were not significantly different from unfiltered or total concentrations, indicating that all of the observed metals in runoff were in a soluble form.

The surface runoff water quality test procedure was conducted on the upland site. Results verified the laboratory predictions; zinc, cadmium, copper, manganese, and nickel were in the dissolved fraction of runoff water in concentrations that exceeded the USEPA Water Quality Criteria. Based on these data, control measures or restrictions are required for dissolved contaminants in surface runoff from the Field Verification Program upland site.

Results of the ground-water monitoring at the upland site indicated that an initial plume of PCBs may have migrated into the ground water after placement of the BRH sediment into the site. However, after 14 months, PCB levels had decreased to below detectable limits, which indicated that any migration from the site had ceased. Analysis of ground water for heavy metals revealed that only cadmium may have migrated from the site into the ground water. Arsenic, manganese, and cadmium concentrations were above Connecticut State standards both in unfiltered and filtered ground-water samples; however, arsenic and manganese concentrations were above standards prior to disposal operations. Only cadmium appeared to continue to migrate from the site after 14 months.

The estuarine plant bioassay procedure was used in the laboratory to evaluate heavy metal uptake by plants from composited BRH sediment. Conduct of the laboratory portion of the bioassay substantiated the chemical predictions. Death of *Spartina alterniflora* in the site was so clearly predicted by the laboratory tests and an in situ field plant bioassay that *S. alterniflora* was not tested further in the field. However, *Sporobolus virginicus* survived in limed dredged material, as predicted. Results from the laboratory test predicted *S. virginicus* grown in the amended dredged material would take up excessive amounts of some of the heavy metals and not take up others. Cadmium and zinc contents in the field-grown plants were relatively close to values observed in the greenhouse. Nickel, chromium, and copper were predicted to be elevated; field results showed, however, that they were not elevated. Lead contents were predicted to be low in greenhouse-grown plants; field-grown plants, however, had higher lead contents.

The US Army Engineer Waterways Experiment Station earthworm bioassay procedure was applied to composited BRH sediment in the laboratory. The initial earthworm bioassay indicated that the sediment was quite toxic. Tests using diluted substrates and substrates rinsed to remove salinity did not indicate elevated tissue levels of heavy metals or organic contaminants. Subsequent tests indicated that the toxicity was apparently due to extreme sediment salinity under upland oxidized conditions. Field verification of the earthworm test was accomplished and showed that the material was indeed toxic to earthworms under field disposal conditions.

SUMMARY

Introduction

The Field Verification Program (FVP) was designed as a cooperative effort between the US Army Corps of Engineers (CE) and the US Environmental Protection Agency (USEPA) to field verify testing procedures for implementing the evaluative requirements of Section 404 of PL 92-500 (Clean Water Act), and Section 103 of PL 92-502 (Ocean Dumping Act). Through the FVP, promising procedures developed by the CE and USEPA were applied to the Black Rock Harbor (BRH) maintenance dredging project in the CE New England Division. The dredged material from this project was placed in both an aquatic disposal site and confined disposal sites in upland and wetland environments. Use of a single highly contaminated dredged material afforded a unique opportunity to evaluate results of disposal under three different disposal alternatives: open water, intertidal, and upland. This report examines only the upland portion of the project.

The specific objectives of this report were to provide the results of field verification of several predictive techniques: (a) verification of procedures for predicting the quality of effluent discharge from the site during drilling operations, (b) verification of procedures for predicting the quality of upland surface runoff resulting from rainfall following disposal, (c) determination of possible changes in ground-water quality following disposal, (d) verification of procedures for predicting the potential for contaminant mobility into plants, and (e) verification of procedures for predicting the potential for contaminant mobility into soil-dwelling animals. Results of the FVP will provide both the CE and USEPA field elements with documented and verified state-of-the-art techniques and interpretative procedures for complying with regulatory requirements for evaluation of dredged material.

Site Description

Separate upland and intertidal disposal sites were designed to meet surface area, elevation, and operational requirements for FVP water quality and contaminant mobility studies. Designs for sedimentation and storage followed recently developed CE procedures.

Provisions were made to ensure that similar BRH dredged material was placed in the FVP open-water, upland, and intertidal sites. The upland and intertidal sites were constructed within a protected area using conventional construction techniques and were hydraulically filled from barges. The filling operation provided conditions typical of confined dredged material disposal operations. Following filling, the weirs at both sites allowed free drainage of surface water as the fill stabilized through consolidation. This is normal site management procedure. Within approximately 9 months, the upland and wetland substrates had stabilized at their desired surface elevations.

Effluent Quality

The prediction of the quality of effluent from confined dredged material disposal areas must account for both the dissolved concentration of contaminants and that fraction associated with the total suspended solids (SS). A modified elutriate procedure was used for laboratory predictions of effluent water quality. This test determined dissolved concentrations and particle-associated contaminants under quiescent settling conditions and accounted for the typical geochemical changes that occurred in the site during disposal operations. A column settling test procedure was also used to predict SS concentration of the effluent for the given operational conditions.

The modified elutriate test adequately predicted the dissolved and particle-associated concentration of contaminants. Comparisons of laboratory test results with field data indicated that the modified elutriate test was a generally conservative predictor leading to a slight overprediction of field effluent concentrations. The column settling analysis and corresponding prediction of effluent SS concentration compared favorably with field data and yielded a conservative estimate of the effluent SS. Effluent SS data collected during disposal indicated that the site was efficient in retaining SS. The relative retention of contaminants within the site also followed this trend, since most contaminants were directly associated with particles. The effect of retention and ponding on physicochemical parameters was varied. Dissolved oxygen levels in the effluent showed marked increases as compared with the influent due to turbulence, mixing, and atmospheric reaeration. These increases confirmed that oxidizing conditions were present in disposal

area ponded waters. Total metal concentrations reflected a high removal due to sedimentation in the disposal area, with an average retention of 98.3 percent. Results for total phosphorus, total organic carbon, and polychlorinated biphenyl (PCB) removal were generally similar to those for metal removal. The USEPA Maximum Water Quality Criteria for Protection of Aquatic Life were, however, exceeded for dissolved copper, nickel, and PCBs.

Surface Runoff

Results of the surface runoff water quality test procedure conducted on wet, BRH sediment in the laboratory showed that contaminants were poorly soluble and tightly bound to the particulates. Total or unfiltered concentrations of heavy metals in surface runoff from the site were predicted to be excessive, but may be easily controlled by allowing the SS to settle out of the surface runoff before being discharged from the disposal site. However, when the BRH sediment was allowed to dry and oxidize, significant physicochemical changes occurred in the material that increased the solubility of some of the contaminants. Dissolved concentrations of cadmium, copper, nickel, zinc, and manganese in surface runoff from the dry, oxidized BRH sediment included all of the unfiltered or total concentrations. This indicated that all of the metals in runoff from the site were in the dissolved form.

The surface runoff water quality test procedure was conducted on BRH dredged material in the site. Results verified the laboratory predictions; cadmium, copper, nickel, zinc, and manganese were in the dissolved fraction of runoff water in concentrations that exceeded the USEPA Water Quality Criteria for both the laboratory and field tests.

Ground-Water Quality

Results of the ground-water monitoring indicated that an initial plume of PCBs had migrated into the ground water after placement of the BRH sediment into the site. However, after 14 months, PCB levels had decreased to below detectable limits, which indicated that continued migration of PCBs from the site had ceased. Analysis of ground water for heavy metals revealed that only cadmium may have migrated from the site into the ground water. Arsenic, manganese, and cadmium concentrations were above Connecticut State standards

both in unfiltered and filtered ground-water samples; however, arsenic and manganese concentrations were above standards prior to disposal operations. Only cadmium appeared to continue to migrate from the site after 14 months. However, because of a lack of predredging background data and possible effects of seasonal fluctuations in the ground water at the site, ground-water monitoring should be continued to evaluate longer term impacts on ground water.

Plant Uptake

The estuarine plant bioassay procedure was used in the laboratory to evaluate heavy metal uptake by plants from composited and homogenized BRH sediment. Chemical analysis of the composited BRH sediment was conducted as part of the plant bioassay procedure and indicated that the BRH sediment at the disposal site would eventually become extremely acidic and highly saline upon air drying. Lime addition and rinsing with fresh water were necessary for growth of the estuarine index plants *Spartina alterniflora* and *Sporobolus virginicus* and subsequent evaluation of plant uptake of heavy metals in the laboratory.

Conduct of the laboratory portion of the plant bioassay procedure substantiated the chemical predictions. Neither index plant species grew in unamended, unrinsed composited BRH sediment. Death of *S. alterniflora* in the site was so clearly predicted by the laboratory tests and an in situ field plant bioassay that it was not tested further in the field. Results from the laboratory test predicted that *S. virginicus* would grow in the amended dredged material and would take up excessive amounts of some of the heavy metals and not take up others. Laboratory test results predicted that concentrations of cadmium in *S. virginicus* would be elevated; field results showed that they appeared to be elevated, but the difference was not statistically significant. Zinc, nickel, chromium, and copper were predicted to be elevated in *S. virginicus*; field results showed, however, that they were not elevated. Lead contents were predicted to be low in laboratory grown *S. virginicus*; field-grown plants, however, had higher lead contents.

Animal Uptake

The FVP and other projects have clearly indicated that many changes relative to toxicity may occur when a sediment is placed in an upland (oxidized) disposal environment. The initial earthworm bioassay indicated that the BRH sediment was quite toxic. Earthworm bioassays using diluted substrates and substrates rinsed to remove salinity were not toxic and did not indicate elevated levels of heavy metals or organic contaminants in the earthworm tissue. Analysis of washed materials indicated that levels of heavy metals and organic contaminants had not changed. These tests with washed sediment have indicated that the toxicity was due primarily to excessive salinity. Field tests verified laboratory test results and indicated that the dredged material at the site was quite toxic, apparently due to excessive salinity. Based on these results, a more realistic field verification of the earthworm test will be accomplished only after the salinity decreases.

PREFACE

This study was conducted by the Environmental Laboratory (EL) of the US Army Engineer Waterways Experiment Station (WES), Vicksburg, Miss., during 1982-1986. The study was part of the Interagency Field Verification of Testing and Predictive Methodologies for Dredged Material Disposal Alternatives Program (Field Verification Program (FVP)). This Program was sponsored by the Office, Chief of Engineers (OCE), US Army, and was assigned to the WES under the auspices of the Environmental Effects of Dredging Program. The OCE Technical Monitors for FVP were Drs. William L. Klesch, Robert J. Pierce, and John Hall. The objectives of this interagency program were to field verify existing predictive techniques for evaluating the environmental consequences of dredged material disposal under aquatic, wetland, and upland conditions. The aquatic portion of the FVP study was conducted by the US Environmental Protection Agency Environmental Research Laboratory, Narragansett, R. I., with the wetland and upland portions conducted by WES.

The study was conducted by personnel of the Plant Bioassay Team, the Ecosystem Biomonitoring Team, the Surface Runoff and Restoration Team, and the Data Management Team of the Contaminant Mobility and Regulatory Criteria Group (CMRCG), Ecosystem Research and Simulation Division (ERSD), and by the Water Resources Engineering Group (WREG) and the Water Supply and Waste Treatment Group (WSWTG) of the Environmental Engineering Division (EED), WES. The Plant Bioassay Team was composed of: Dr. Bobby L. Folsom, Jr., Team Leader; Ms. Judith C. Pennington; CAPT Todd R. Higgins; the late Ms Karen M. Garner (Preston); Ms. Cynthia L. Teeter; and Ms. Joycie R. Bright. The Ecosystem Biomonitoring Team was composed of: Dr. John W. Simmers, Team Leader; Dr. Henry E. Tatem; Ms. Carole P. Brown; Mr. Peter J. Pikul; Mr. R. Morris Richards; Mr. R. Glenn Rhett; Ms. Susan A. Portzer; and Ms. Maryann Tweedle. The Surface Runoff and Restoration Team was composed of: Mr. John G. Skogerboe, Team Leader; Mr. Richard A. Price; Mr. George Hollins; LT Kurt Eskew; and Mr. Hugh McKenzie. Statistical analysis was provided by Mr. Dennis L. Brandon of the Data Management Team. Dr. Michael R. Palermo, Mr. Stephen A. Pranger, Ms. Marian Poindexter, Ms. Katherine M. Smart, and Mr. Donald L. Hayes, WREG, were responsible for the effluent water quality studies. Mr. Richard A. Shafer, WSWTG, was responsible for the ground-water studies. The study was under the general supervision of Dr. Charles R. Lee,

Chief, CMRCG; Mr. Donald L. Robey, Chief, ERSD; Dr. Raymond L. Montgomery, Chief, EED; and Dr. John Harrison, Chief, EL. Dr. Robert M. Engler was the Environmental Effects of Dredging Program Manager at the completion of the study, and Mr. Charles C. Calhoun, Jr., was the previous Program Manager. The FVP Coordinator was Mr. Robert L. Lazor. Dr. Thomas D. Wright was the Technical Coordinator for the FVP reports.

This report was written by Dr. Folsom, Mr. Skogerboe, Dr. Palermo, Dr. Simmers, Mr. Pranger, and Mr. Shafer and was edited by Ms. Lee T. Byrne of the WES Information Products Division, Information Technology Laboratory.

Appreciation is expressed to Ms. Martha R. Barton, Mr. Horace C. Allen, Mr. James R. Kemp, and Mr. Gary Emerson of the Plant Bioassay Team for their help in conducting some of the experimentation during the course of this study.

COL Dwayne G. Lee, EN, was the Commander and Director of WES.
Dr. Robert W. Whalin was Technical Director.

This report should be cited as follows:

Folsom, B. L., Jr., Skogerboe, J. G., Palermo, M. R., Simmers, J. W., Pranger, S. A., and Shafer, R. A. 1988. "Synthesis of the Results of the Field Verification Program Upland Disposal Alternative," Technical Report D-88-7, US Army Engineer Waterways Experiment Station, Vicksburg, Miss.

CONTENTS

	<u>Page</u>
SUMMARY.....	1
Introduction.....	1
Site Description.....	1
Effluent Quality.....	2
Surface Runoff.....	3
Ground-Water Quality.....	3
Plant Uptake.....	4
Animal Uptake.....	5
PREFACE.....	6
LIST OF TABLES.....	10
LIST OF FIGURES.....	10
PART I: INTRODUCTION.....	12
Background.....	12
Objectives.....	12
Approach.....	13
PART II: SITE CONSTRUCTION.....	18
Field Study Requirements.....	18
Site Selection and Design.....	18
Site Construction.....	21
Weir Structures.....	22
Instrumentation.....	23
Dredging and Filling Operations.....	23
Site Management and Fill Stabilization.....	25
PART III: LABORATORY AND FIELD PROCEDURES.....	27
Ground-Water Monitoring.....	27
Sediment Collection and Mixing.....	29
Laboratory Procedures.....	30
Field Procedures.....	40
Site Management for Controlling Surface Runoff Water Quality.....	45
PART IV: LABORATORY AND FIELD TEST RESULTS.....	48
Effluent Water Quality.....	48
Surface Runoff Water Quality.....	53
Site Management for Controlling Surface Runoff Water Quality.....	55
Ground-Water Monitoring.....	57
Plant Response.....	60
Animal Response.....	64
PART V: DISCUSSION.....	67
Effluent Water Quality.....	67
Surface Runoff Water Quality.....	71
Site Management for Controlling Surface Runoff Water Quality.....	72
Ground-Water Monitoring.....	73
Plant Response.....	74

CONTENTS (Continued)

	<u>Page</u>
Animal Response.....	75
Field Verification of Laboratory Methods Placed Under Field Conditions.....	75
PART VI: CONCLUSIONS.....	76
Effluent Water Quality.....	76
Surface Runoff Water Quality.....	76
Ground Water.....	77
Plant Bioassay.....	77
Animal Bioassay.....	77
PART VII: RECOMMENDATIONS.....	79
Effluent Water Quality.....	79
Surface Runoff Water Quality.....	79
Ground Water.....	80
Plant Bioassay.....	80
Animal Bioassay.....	80
REFERENCES.....	81
BIBLIOGRAPHY.....	84

LIST OF TABLES

<u>No.</u>		<u>Page</u>
1	Summary of Results from Modified Elutriate Test and Predicted Total Concentrations of Contaminants.....	34
2	Summary of Field Results.....	49
3	Surface Runoff Water Quality from Wet Sediment and Dredged Material.....	54
4	Surface Runoff Water Quality from Dry, Oxidized Sediment and Dredged Material.....	55
5	Effects of Drying and Oxidation on Surface Runoff Water Quality from the BRH Field Site.....	56
6	Effect of Soil Amendments on Filtered and Unfiltered Heavy Metal Concentrations.....	57
7	Percent Soluble Heavy Metals in Surface Runoff from Field Plots Treated with Different Soil Amendments.....	58
8	PCB Ground-Water Analysis at the FVP Field Site.....	58
9	Metal Analysis of Ground Water at the FVP Field Site.....	59
10	Selected Physical and Chemical Parameters of BRH Sediment.....	61
11	Total Acid Digestible and DTPA Extractable Concentrations ($\mu\text{g/g}$) of Selected Metals in BRH Sediment.....	61
12	Plant Content ($\mu\text{g/g}$) of Selected Metals in Leaf Tissue of <i>S. alterniflora</i> Grown in Sediment from BRH.....	63
13	Plant Content ($\mu\text{g/g}$) of Selected Metals in Leaf Tissue of <i>S. virginicus</i> Grown in Sediment from BRH.....	63
14	Weight Changes of Earthworms After 7-Day Exposure to Various Substrates (BRH).....	65
15	Contaminant Concentrations in Earthworms After a 7-Day Laboratory Exposure to Various Substrates.....	66
16	Ratios of Predicted Effluent Concentrations to Field Mean Effluent Concentrations.....	70

LIST OF FIGURES

<u>No.</u>		<u>Page</u>
1	Locations of BRH dredging area and disposal sites.....	13
2	Site plan for Tongue Point study area.....	20
3	FVP wetland site on the day following cessation of disposal operations.....	22
4	FVP upland site midway through disposal operations.....	23
5	Water jet and pump intake used for filling operations.....	25

<u>No.</u>		<u>Page</u>
6	Plot of dredged material surface elevation versus time following completion of filling for FVP upland and wetland sites.....	26
7	Location of monitoring wells at FVP upland site.....	28
8	Schematic diagram of monitoring wells.....	28
9	Location of the 25 sample collection points located along the BRH Channel.....	29
10	Box corer used to collect BRH sediment samples.....	30
11	Modified elutriate test procedure.....	31
12	Schematic of apparatus for column settling test.....	35
13	Schematic of the WES rainfall simulator-lysimeter system.....	37
14	Schematic diagram of the plant bioassay apparatus used in the study.....	38
15	Schematic diagram of the animal bioassay apparatus used in the study.....	40
16	Dye tracer curve for FVP upland site.....	41
17	Influent pipe.....	42
18	Effluent pipe.....	42
19	Construction of field rainfall simulator plots.....	44
20	Influent and effluent TSS concentrations.....	50
21	Influent and effluent DO concentrations.....	51
22	Influent and effluent copper concentrations.....	52
23	Plots of means and standard deviations of modified elutriate laboratory test and measured field data, BRH.....	68
24	Plots of means and standard deviations of laboratory predicted and measured field data for total concentrations of contaminants.....	69

SYNTHESIS OF THE RESULTS OF THE FIELD VERIFICATION PROGRAM
UPLAND DISPOSAL ALTERNATIVE

PART I: INTRODUCTION

Background

1. Evaluation of proposed dredged material discharge, under Section 103 of the Ocean Dumping Act (PL 92-502) and Section 404 and the Clean Water Act (PL 92-500), requires field verified, state-of-the-art procedures for prediction and assessment of environmental effects. Potential bioaccumulation and biomagnification of contaminants in organisms and degradation of water quality must be addressed as part of these evaluations. Furthermore, a weighing and balancing of potential environmental impact of all disposal alternatives must be considered.

2. The Field Verification Program (FVP) was designed as a cooperative effort between the US Army Corps of Engineers (CE) and the US Environmental Protection Agency (USEPA) to field verify testing procedures for implementing the requirements of Sections 404 and 103. Through the FVP, promising procedures developed by the CE and USEPA were applied to contaminated dredged material from the Black Rock Harbor (BRH) maintenance dredging project in the CE New England Division (Figure 1). The dredged material from this project was placed in both an aquatic disposal site and confined disposal sites in upland and wetland environments. Use of a single highly contaminated dredged material afforded a unique opportunity to evaluate results of disposal under three different disposal alternatives: open water, intertidal (wetland), and upland. This report examines only the upland portion of the project. Results of the FVP will provide both the CE and USEPA field elements with documented and verified state-of-the-art techniques and interpretative procedures for complying with the regulatory requirements for evaluation of dredged material.

Objectives

3. The specific objectives of this report were to provide the results of field verification of several predictive techniques:

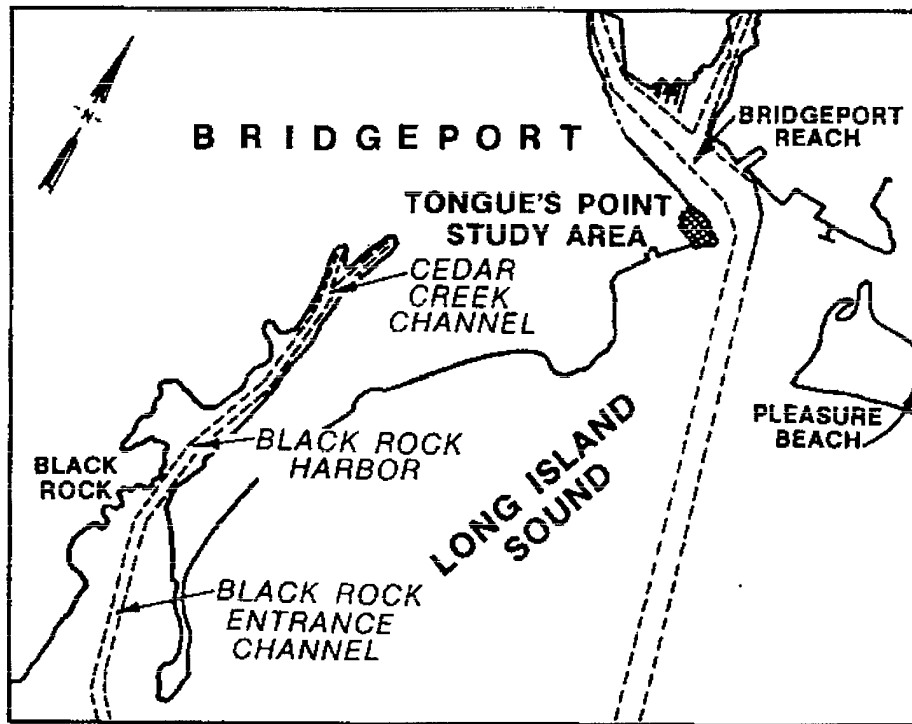

Figure 1. Locations of BRH dredging area and disposal sites

- a. Verification of procedures for predicting the quality of effluent discharge from the upland site during filling operations.
- b. Verification of procedures for predicting the quality of upland surface runoff resulting from rainfall following disposal.
- c. Determination of possible changes in ground-water quality following disposal.
- d. Verification of procedures for predicting the potential for contaminant mobility into plants under upland conditions.
- e. Verification of procedures for predicting the potential for contaminant mobility into soil-dwelling animals under upland conditions.

Approach

Prediction of effluent water quality

4. Confined dredged material disposal has increased in recent years, primarily because of environmental constraints on open-water disposal of dredged material classified as unacceptable for unconfined disposal. Release

of contaminants from dredged material in the effluent from confined disposal areas* is dependent upon a number of factors relating to the physical, geochemical, and physicochemical characteristics of the dredged material in relation to the confined disposal. The term "effluent" is defined for purposes of this report as water that is discharged on a continuous or intermittent basis from confined disposal areas as they are being hydraulically filled during active disposal operations.

5. The effluent from confined disposal areas is considered a dredged material discharge under Section 404 of the Clean Water Act. Regulatory guidance and evaluation procedures have recently been developed to predict contaminant release in effluent from confined disposal operations (Palermo 1985, 1986a, and 1986b). The field evaluations described in this report were conducted to field verify these procedures.

6. Dredged material placed in a confined disposal area undergoes settling and consolidation resulting in a "thickened" deposit of settled material overlaid by the clarified supernatant. The supernatant waters are normally discharged from the site as effluent during active dredging operations. The effluent may contain both dissolved and particle-associated (adsorbed, coprecipitated, ion exchanged, etc.) contaminants. The majority of the total concentration of contaminants is commonly associated with particles.

7. Release of supernatant waters as effluent from confined disposal areas occurs after a retention time that ranges from hours to weeks. Furthermore, actual discharge of supernatant is governed by the design and operation of the disposal area and location and operation of the discharge weir or structure.

8. Several factors influence the concentration of suspended particles and contaminants present in supernatant waters. A dredged material slurry enters the ponded water as a density flow. Fine particles remain suspended in the disposal area water column at the point of entry due to turbulence mixing. The suspended particles are partially removed from the water column by gravity settling. However, some of the settled particles may reenter the water column because of the upward flow of water through the slurry mass during compaction

* The terms "confined disposal area," "confined disposal site," "diked disposal area," "containment area," and "confined disposal facility" are used interchangeably in the literature. In this report, "confined disposal area" is the term of choice.

(or thickening). Wind and/or surface wave action will also resuspend settled particles. If carrier water is released during active phases of disposal, all solids cannot be retained, and adsorbed and associated contaminants are transported with the particles in the effluent to the receiving water outside the containment area.

9. The prediction of the quality of effluent from confined dredged material disposal areas must account for both the dissolved concentration of contaminants and for that fraction associated with the total suspended solids (TSS) that are released. A modified elutriate procedure recently developed for this purpose was used to make laboratory predictions of effluent water quality for this study (Palermo 1985, 1986a, and 1986b). This test determines dissolved concentrations and particle-associated contaminants under quiescent settling conditions and considers the geochemical changes occurring in the disposal area during active disposal operations.

10. A column settling test procedure (Montgomery 1979; Palermo, Montgomery, and Poindexter 1978; Palermo 1985 and 1986b) was also used to predict water quality of the effluent for the given operational conditions present at the FVP field site. Based on results from these procedures, total concentration of contaminants in the effluent was predicted.

Prediction of surface runoff water quality

11. The US Army Engineer Waterways Experiment Station (WES) Surface Runoff Water Quality Test procedure (Westerdahl and Skogerboe 1982) was used in the laboratory to predict surface runoff water quality. Rainfall simulations were conducted on BRH sediment using the WES rainfall simulator during the early wet, anaerobic stage of the drying process. After the sediment had completely dried and oxidized (a process that required more than 6 months), rainfall simulations were again conducted, and runoff samples were collected and analyzed. This series of tests represented the laboratory prediction of effects in the field.

12. After filling of the FVP upland disposal site, field plots were established to conduct field rainfall simulations on the dredged material. Additional dredged material was collected from the field site soon after disposal and transported to the WES to conduct additional laboratory surface runoff water quality tests. Rainfall simulations were conducted on the field plots and on the dredged material taken to the WES. Surface runoff water

quality predicted in laboratory tests was compared with the field surface runoff water quality. Both laboratory-predicted surface runoff water quality and field surface runoff water quality were compared with the USEPA Maximum Allowable Criteria for the Protection of Aquatic Life to predict potential adverse environmental impacts due to surface runoff water quality.

Site management for controlling surface runoff water quality

13. The results of the surface runoff water quality tests conducted on the original BRH sediment predicted that the actual upland field site should be managed so as to prevent unrestricted surface runoff from being discharged from the site. Within the FVP upland field site, a series of tests and demonstrations were conducted to determine the feasibility of using soil amendments and adapted plant species to control surface runoff water quality. Soil amendments and plant species were selected from a recently developed Instruction Report (Lee et al. 1985). The soil amendments and plant species were selected to establish vegetation and to reduce heavy metals in surface runoff. The WES Rainfall Simulator was then used to quantify the surface runoff water quality from several of the treatments.

Ground-water monitoring

14. Wells were installed to detect the potential for movement of leachate from the site into the ground water. Analysis of ground-water samples was intended to give only a qualitative indication of the potential for contaminants to leach out of the dredged material and migrate into ground water. It is realized that the ground-water aquifer potentially receives impacts from other sources in addition to the BRH site.

Prediction of potential contaminant mobility and toxicity into plants

15. A plant bioassay procedure was developed to evaluate the potential for mobility from sediments of contaminants that are phytotoxic and/or are bioaccumulated by plants (Folsom and Lee 1981a and 1981b). The plant bioassay procedure was shown to be an excellent tool for predicting whether or not heavy metals (e.g., zinc and cadmium) were potentially bioaccumulated from freshwater sediments. The plant bioassay procedure used *Cyperus esculentus* as the freshwater index plant. The freshwater plant bioassay procedure was modified and applied to an estuarine environment (Folsom and Lee 1985). The estuarine index plants were *Spartina alterniflora* and *Sporobolus virginicus*.

Folsom and Lee (1985) and Lee et al. (1985) demonstrated that diethylenetriaminepentaacetic acid (DTPA) extraction data indicated that plant uptake from air-dried oxidized estuarine sediments would be substantially greater than that from the same estuarine sediments under flooded reduced conditions. They suspected that potentially greater plant uptake from sediment under air-dried oxidized conditions should be enhanced after excess salt had been leached from the dredged material. The estuarine plant bioassay procedure of Folsom and Lee (1985) was used in the laboratory to evaluate contaminant uptake by plants from BRH sediment. Results of the plant bioassay are described in a later section.

Prediction of potential toxicity
and/or contaminant mobility into animals

16. The WES earthworm bioassay procedure (Rhett, Simmers, and Lee 1986) was applied to predict potential biological effects of upland (oxidized) disposal of the BRH sediment. BRH sediment was collected and transported to the WES for bioassay tests. Previous research (Simmers et al. 1986) has shown that removal of excess salt is necessary for earthworm survival. However, the salt leaching and drying process could enhance contaminant uptake. Results of the earthworm bioassay procedure are described later.

PART II: SITE CONSTRUCTION

Field Study Requirements

17. This section of the report describes the design, construction, operation, and management of the FVP upland and wetland sites.* This section of the report also describes how the sites, as constructed and operated, fulfilled the various field study requirements for the FVP upland and wetland studies. The FVP upland and wetland sites had to meet specific design, construction, operation, and management requirements necessary for the various portions of the study. These requirements included the following:

- a. Dredged material placed in the upland and wetland sites must be similar to material placed at the FVP open-water disposal study site to ensure valid comparison of results.
- b. Dredged material must be hydraulically placed within the sites in a manner normally used for confined disposal.
- c. A minimum thickness of dredged material of 0.762 m must be achieved in both upland and wetland sites following sedimentation and consolidation.
- d. A minimum required surface area (inside dike toes) of 2,415 sq m for the upland and 743.2 sq m for the wetland must be provided to allow for the placement of study plots.
- e. Surface elevations following sedimentation and initial consolidation must be at least 0.914 m above mean-high-water (mhw) elevation for the upland and within the intertidal range for the wetland.

Site Selection and Design

Site selection

18. The FVP used contaminated dredged material from a project located in a highly industrialized coastal area. Therefore, potential sites for upland disposal and for wetland creation were difficult to locate. Several sites were extensively studied, and preliminary designs and cost estimates were prepared. Both the enclosure of small embayments immediately adjacent

* M. R. Palermo and S. A. Pranger. 1984. "Field Verification Program: Upland/Wetland Site Design, Construction and Operation," Engineer Technical Letter, Department of the Army, Office of the Chief of Engineers, Washington, DC.

to the BRH channel and upland sites in the immediate vicinity were considered. All such sites were ultimately rejected because of real estate problems or cost constraints. The site holding the best potential from a real estate and cost standpoint, and the site ultimately selected, was located at Tongue Point, Conn., about 4.5 nautical miles (8.3 km) from the BRH Channel (Figure 1). Although use of this site presented some constraints regarding the transportation and placement of dredged material, its preconstruction setting and availability of required surface area presented significant technical and cost advantages.

19. The Tongue Point site is located on property owned by United Illuminating Company, a local electric utility. The test site location was originally constructed 20 to 25 years ago by diking an area of approximately 2.025 ha adjacent to the Bridgeport Harbor Channel and filling with random fill material and construction debris. An access road was constructed atop the dike, and a 38.1-cm culvert was placed through the dike roadway to allow site drainage. Over the subsequent years, tidal flow through the culvert resulted in the establishment of a saltwater intertidal wetland. Upland areas were also established within the roadway enclosure.

20. The mean-high-tide (mht) elevation at Tongue Point is +2.073-m mean low water (mlw). During the site surveys, it was noted that the culvert acted as a constriction to the tidal flow, causing a time lag for high and low tide and a difference in the tidal elevations within and outside the roadway enclosure. High tide within the enclosure was observed to be +1.737-m mlw, 0.335 m lower than high tide in Bridgeport Harbor.

21. Areas within the roadway enclosure for the FVP upland and wetland sites were chosen in consultation with interested State and Federal agencies and the property owner. Separated upland and wetland sites were chosen to ease construction and management. The final size and orientation of the sites were based on minimum study requirements, site designs, existing topography, and tidal flow conditions within the enclosed area. A site plan is shown in Figure 2.

Site design

22. For purposes of this report, site design refers to the evaluation of storage capacity and sedimentation capacity for the sites. Such evaluations were necessary for achieving effective settling during disposal and

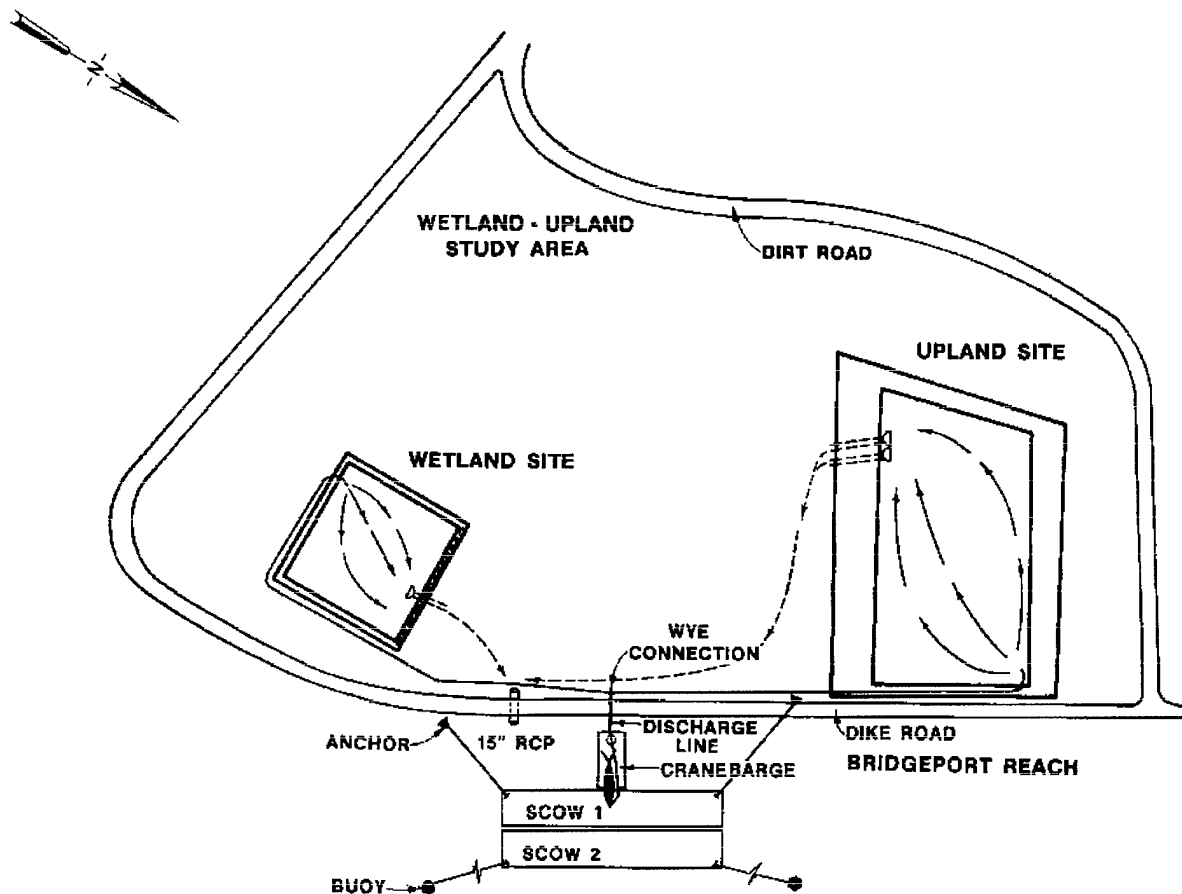

Figure 2. Site plan for Tongue Point Study area

desired ultimate configuration of the substrate for both the upland and wetland sites.

23. The available surface areas for the sites were limited; therefore, the major effort or concern of the sedimentation design was to match a maximum allowable filling rate to the available volume for ponding.

24. Procedures found in Palermo, Montgomery, and Poindexter (1978) and Palermo (1985) were followed for the designs. Sediments were sampled from the BRH and composited for testing (see Part III). Settling tests on sediment subsamples were performed in 20.3-cm-diam columns to determine sedimentation properties of the material and the requirements for the storage during dredging. Consolidation tests were also performed to determine the time rates of settlement for the dredged material.

25. Results from the sedimentation tests indicated that the available ponding for the sites could maintain effective settling for a maximum flow rate of approximately 28.3 l/sec. Data on nomograms (Palermo, Montgomery, and Poindexter 1978) were used to select required weir crest lengths to pass the

flow during filling without resuspending settled material. A weir length of 1.219 m was selected for the wetland site, and two 1.219-m weirs were selected for the upland site.

26. Settling test results were used to determine the required volume for initial storage (during dredging). Minimum freeboard and ponding requirements and available surface areas were then considered in setting required dike crown elevations and bottom grades for both the upland and wetland sites. These elevation were +4.267- and 2.134-m mlw for the upland and +2.743- and 0.914-m mlw for wetland, respectively.

27. The final desired substrate elevation for the upland was +2.652-m mlw or greater, or at least 0.914 m above the mht elevation (+1.737-m mlw) within the roadway enclosure. The final desired substrate elevation for the wetland was +1.676-m mlw, slightly below the mht elevation. Results from the consolidation tests indicated that approximately 3,058 cu m of in situ channel material must be placed in the sites to achieve final substrate elevations desired, or 2,294 cu m in the upland and 764.6 cu m in the wetland.

Site Construction

28. The upland and wetland sites were constructed by grading and dike construction along designated center lines. Both grade elevation and dike crown elevation were determined as part of the site design. All earthwork was performed by conventional construction equipment.

Wetland

29. In general, the wetland construction involved excavation of foundation material to the elevations required to achieve a lower bottom grade (accommodating the required dredged material thickness and still allowing the surface elevation to remain within the intertidal range). A sandbag dike along one side of the site was constructed so that it could be removed after filling, if desired, to provide easy tidal interchange. The final bottom grade for the wetland varied from +1.25 m through +0.914 m at the center to +0.701-m mlw, sloping downward from the inflow point toward the weir. Final wetland dike crown elevations were +2.743- to +2.896-m mlw, and total surface area was approximately 7,060 sq m. A photograph of the wetland site is shown in Figure 3.



Figure 3. FVP wetland site on the day following cessation of disposal operations

Upland

30. Only minimum bottom grading was required in the upland site. Final bottom grade varied from +2.134- to +1.524-m mlw, sloping downward from the inflow point toward the weir. An area immediately around the weir was sloped downward to elevation +1.524 m to ensure a drainage gradient toward the weir in order to ease later management of the site. Dikes for the upland site involved the greatest construction effort. Material excavated from the wetland site and material from an adjacent borrow area were used in the dike construction. Final upland dike crown elevations ranged from +4.267- to +4.572-m mlw with top widths of 1.219 to 1.828 m. Total surface area was approximately 25,826 sq m. A photograph of the upland site is shown in Figure 4.

Weir Structure

31. Weir structures consisted of 1.219-m-diam drop inlets welded to baseplates and ballasted to prevent uplifting during filling operations. The weirs had provisions for adjustable risers of various sizes to finely adjust overflow if required.

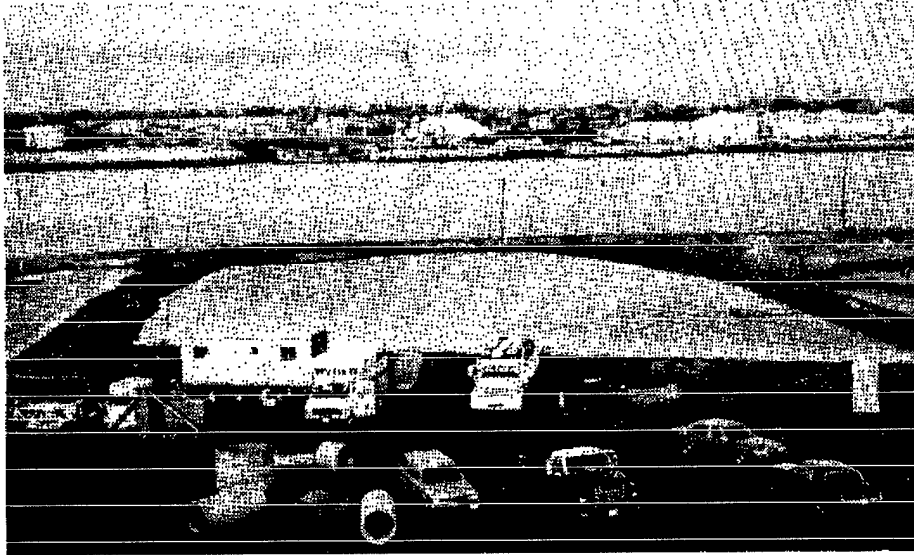

Figure 4. FVP upland site midway through disposal operations

Instrumentation

32. Instrumentation consisting of settlement plates and observation wells was installed during construction. Settlement plates consisting of vertical risers marked at 6-cm intervals were placed in both sites to monitor consolidation of the fills. Observation wells were installed in the center and along the outside toe of each dike segment in the upland site. The wells were used for ground-water sampling before and after filling.

Dredging and Filling Operations

Dredging

33. Since the available sites for upland and wetland studies were located at a distance from the BRH Channel, transportation and off-loading of the material from barges were required. Material was removed by clamshell dredge from the channel for the FVP open-water studies, leaving a strip of the channel extending throughout the undredged reach. This undredged strip was later used for acquiring the upland/wetland material, meeting the requirement that the same sediment be used for upland, wetland, and the open-water sites. As the upland/wetland sites were readied to receive the material, a 10-cu m clamshell dredge excavated approximately 4,588 cu m from the reach and placed

the material into two 3,058-cu m-capacity barges. The dredging operation was easily accomplished within 24 hr. During the dredging, the clamshell bucket easily penetrated the material, removing full cuts at their in situ density. Therefore, the material in the filled barges was essentially in its in-channel condition. The barges were then transported to a mooring barge located adjacent to the site.

Filling operation

34. The test sites were filled with BRH sediment during the last part of October 1983. A pumpout plan was developed to meet the study requirement that the material be hydraulically placed in the sites in a manner typical of confined dredged material disposal. During initial pumping, several intakes and equipment combinations were tried. A pump combination consisting of a 15.2-cm submersible pump, a 15.2-cm booster pump, and an attached 7.62-cm jet pump for adding slurry water was finally selected. Another 10.16-cm pump was used for additional slurry water as necessary. A crane was used to manipulate the intake within the barges. The pump intake is shown in Figure 5. A 15.2-cm dredge pipe, equipped with a wye-valve, split the dredged material inflow between the upland and wetland site. During filling, the flow was proportioned between the sites according to their respective surface areas and depths of filling. This assured that essentially similar dredged material was placed in both sites.

35. During the filling period, the inflow slurry solids concentration ranged from 50 to 100 g/l with a mean of approximately 61 g/l. Intermittent pumping was used to maintain the flow rate at the maximum allowable 28.32 l/sec. Filling was accomplished within a 13-day period. The mean effluent suspended solids (SS) concentration was approximately 173 mg/l. The site, therefore, had a high solids retention efficiency (99.7 percent) indicating that the minimum flow rate as determined from the sedimentation design was adequate for the ponding area available.

36. Measurements of solids concentration and accumulated depth of slurry were taken periodically during the filling operation to monitor the material volume and density. Filling was stopped when volumes and densities in both upland and wetland were such that, after consolidation, the substrate surfaces would be at the desired elevations.

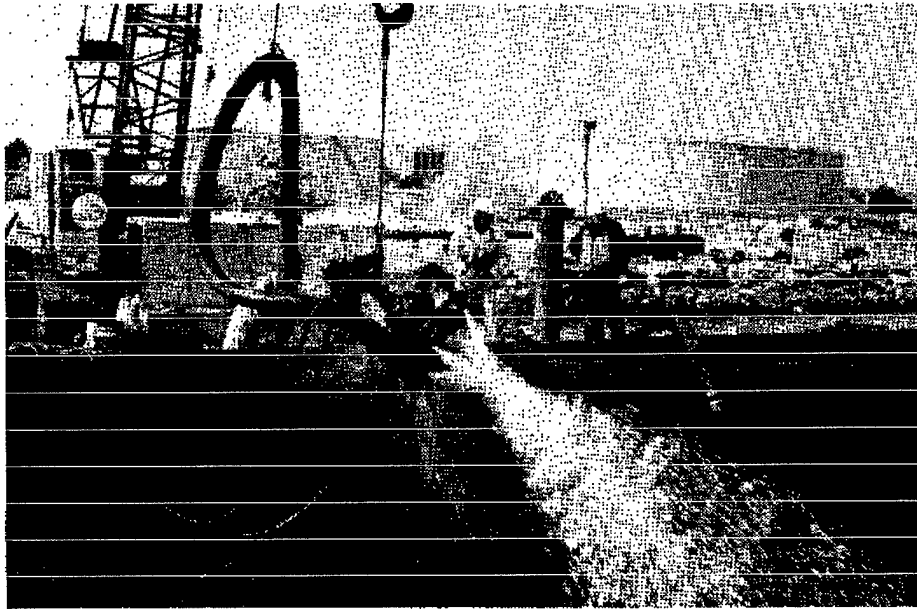

Figure 5. Water jet and pump intake used for filling operations

Site Management and Fill Stabilization

Wetland

37. Weir boards were lowered in the wetland site following the filling operation as consolidation of the fill progressed. This allowed an interchange of tidal flow through the weir structure. The sandbag dike was not breached during the initial stages of fill consolidation to ensure minimal erosion of the dredged material. The rate of consolidation is shown in Figure 6. By late August 1984, the average surface elevation had fallen to +1.676-m mlw due to consolidation, equal to the desired substrate elevation.

Upland

38. Following the filling in October 1983, the ponded water was decanted from the upland site by removing weir boards. A designed slight gradient downward toward the weir structure was observed. Ponded water was left standing in a small area immediately in front of the weir to prevent erosion of the freshly placed material through surface water runoff. Since the sites were filled in late October, only the initial stages of consolidation and stabilization took place prior to winter freezing of surface water. Following the thaw, ponded water was again able to drain from the surface, and weir boards were removed as consolidation progressed. By August 1984, in the

**BLACK ROCK HARBOR
ELEVATION OF CONSOLIDATED DREDGED MATERIAL AT SITE**

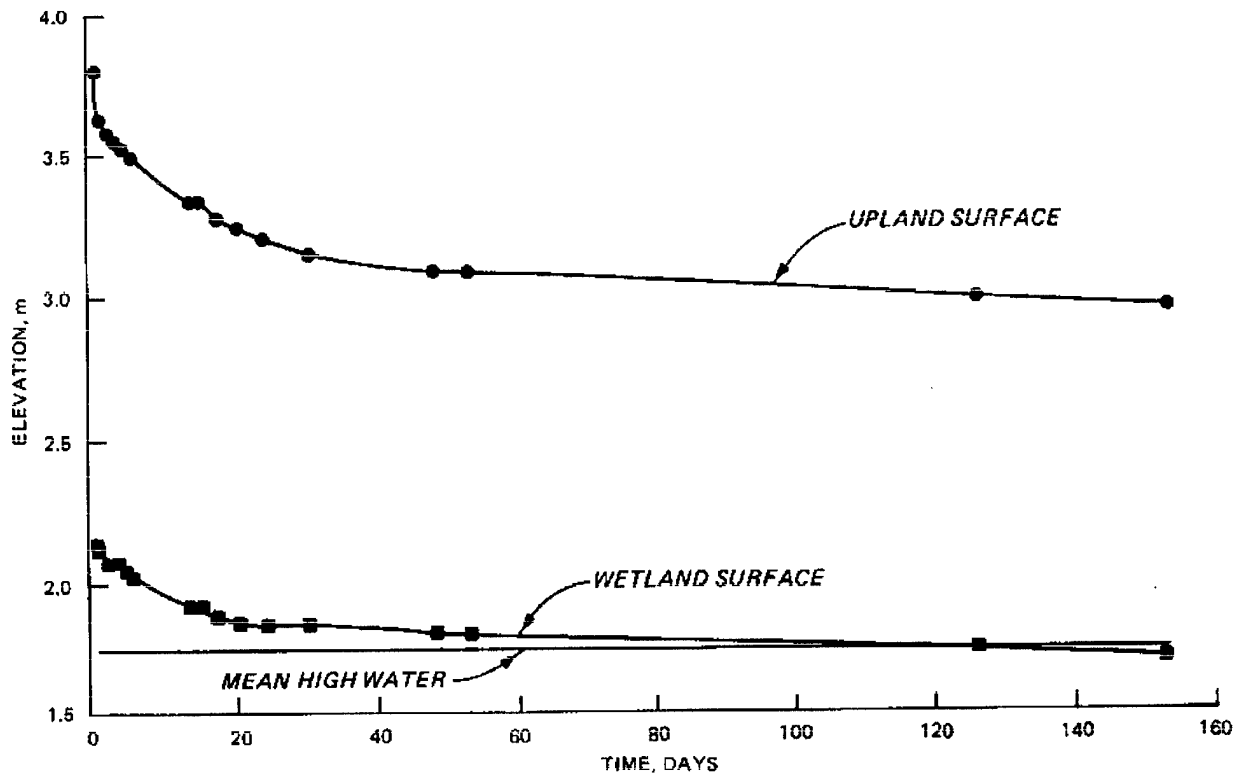

Figure 6. Plot of dredged material surface elevation versus time following completion of filling for FVP upland and wetland sites

upland site, a dried surface crust of approximately 20.32-cm thickness had developed in the area near where the inlet pipe had been located, and personnel could easily walk on the surface crust. The rate of consolidation determined from the settlement plate data is shown in Figure 6. By late August 1984, the average surface elevation had fallen to approximately +2.926-m mlw due to consolidation. This elevation was well above the minimum required elevation of +2.652-m mlw.

PART III: LABORATORY AND FIELD PROCEDURES

Ground-Water Monitoring

39. Ground-water samples were taken from four monitoring wells (Figure 7) prior to filling with BRH dredged material and from all six wells at 6-, 12-, and 14-month intervals after disposal (dredging schedule conflicts prevented sampling all wells prior to filling). Four of the wells were installed at the toe near the center of each side of the perimeter dike of the FVP upland site; the other two were installed inside the upland area. The wells were fabricated using 10.16-cm Schedule 40 polyvinyl chloride (PVC) pipe with screw-type fittings and 10.16-cm Schedule 40 PVC well screen (Figure 8). The slotted PVC well screen was inserted into the well boring, and washed sand was poured into the boring surrounding the well screen. Washed pit-run sand was packed around the PVC well screen and PVC pipe to within 0.6096 m of the surface as the drill casing was retracted. Bentonite pellets were then placed to within 0.3048 m of the surface to form an impervious plug. After installation, the wells were developed by pumping with a centrifugal pump. The suction hose to the pump was lowered into the well to a point that allowed the pump to discharge at a constant rate. A protective 15.2-cm steel casing with a locking cap was installed over each of the wells.

40. Ground-water samples were taken from four of the wells prior to disposal and at 6-, 12-, and 14-month intervals after disposal. The afternoon before sampling, the water level in each well was measured; then the well was bailed. The next morning, water levels were measured, and samples were taken with a Teflon bailer (USEPA 1982). Samples were collected from the six monitoring wells and analyzed for polychlorinated biphenyls (PCBs), heavy metals, ammonia nitrogen, nitrate nitrogen, total organic carbon, oil and grease (O&G), SS, pH, temperature, salinity, and electrical conductivity (EC) using appropriate preservation techniques for each parameter. Chemical analyses were performed on unfiltered samples for all but the 14-month sample collection. Both filtered (0.45- μ m) and unfiltered samples were analyzed for the 14-month samples.

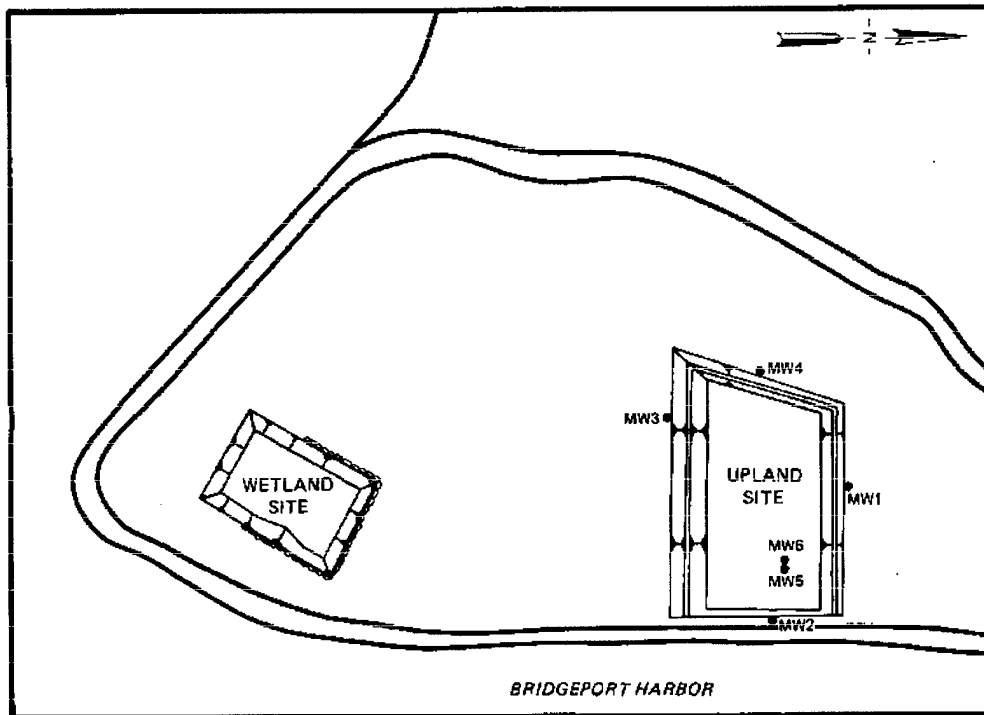

Figure 7. Location of monitoring wells at FVP upland site

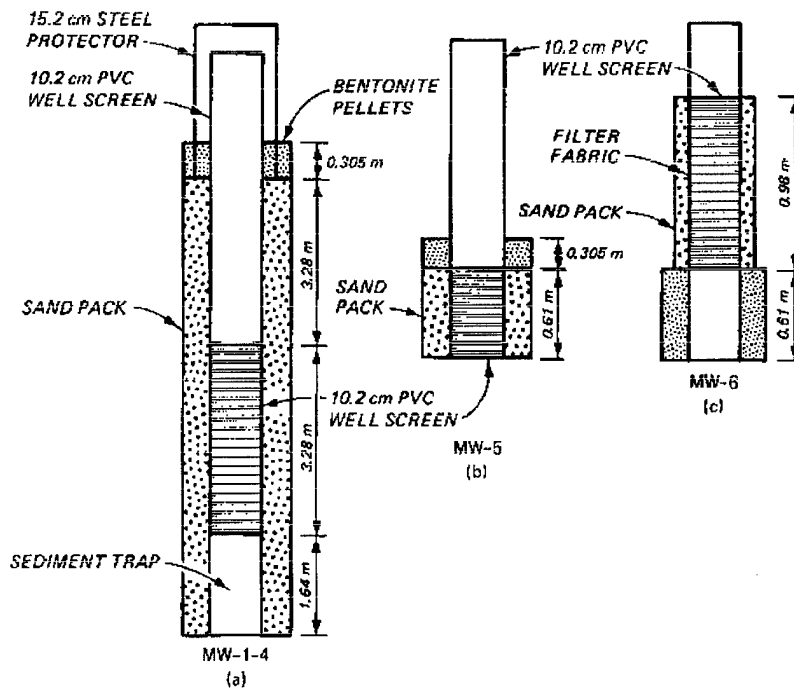

Figure 8. Schematic diagram of monitoring wells

Sediment Collection and Mixing

41. Prior to dredging, sediment samples were collected from 25 locations along the BRH Channel (Figure 9). The samples were collected using a box-corer sampler (Figure 10). Samples were taken using the box corer from the mouth of the harbor up to the point where Federal maintenance of the navigation channel stops. The boat was positioned above the desired location, and the box corer was lowered by cable and allowed to penetrate the sediment (generally 0.5 to 1.0 m). The box corer was lifted out of the water and positioned over a washed 208-l steel drum, the bottom of the corer opened, and the sediment in the corer allowed to drop into the drum. The drum was sealed with its included lid. The drums were off-loaded from the boat and placed into a refrigerated (4° C) truck. The drums were subsequently transported to the WES and composited (Folsom and Lee 1982). Upon arrival at the WES, the sediment in each drum was subsampled before being poured into a cement truck

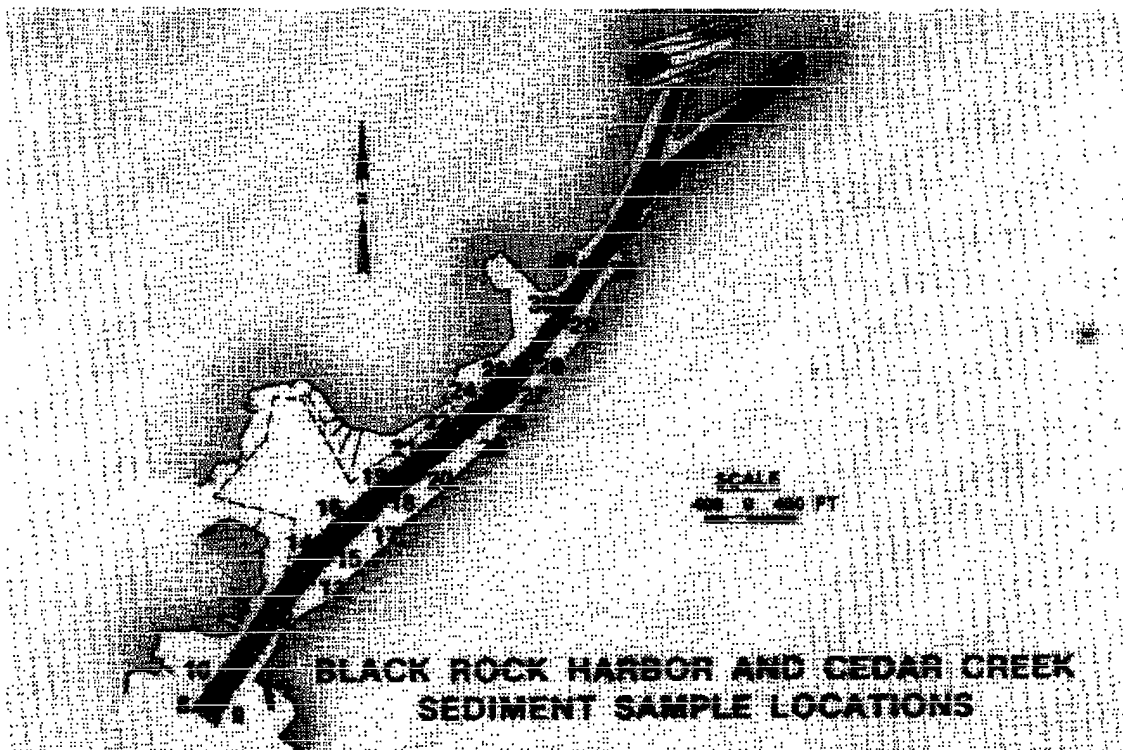

Figure 9. Location of the 25 sample collection points located along the BRH Channel*

* To convert feet into metres, multiply by 0.3048.

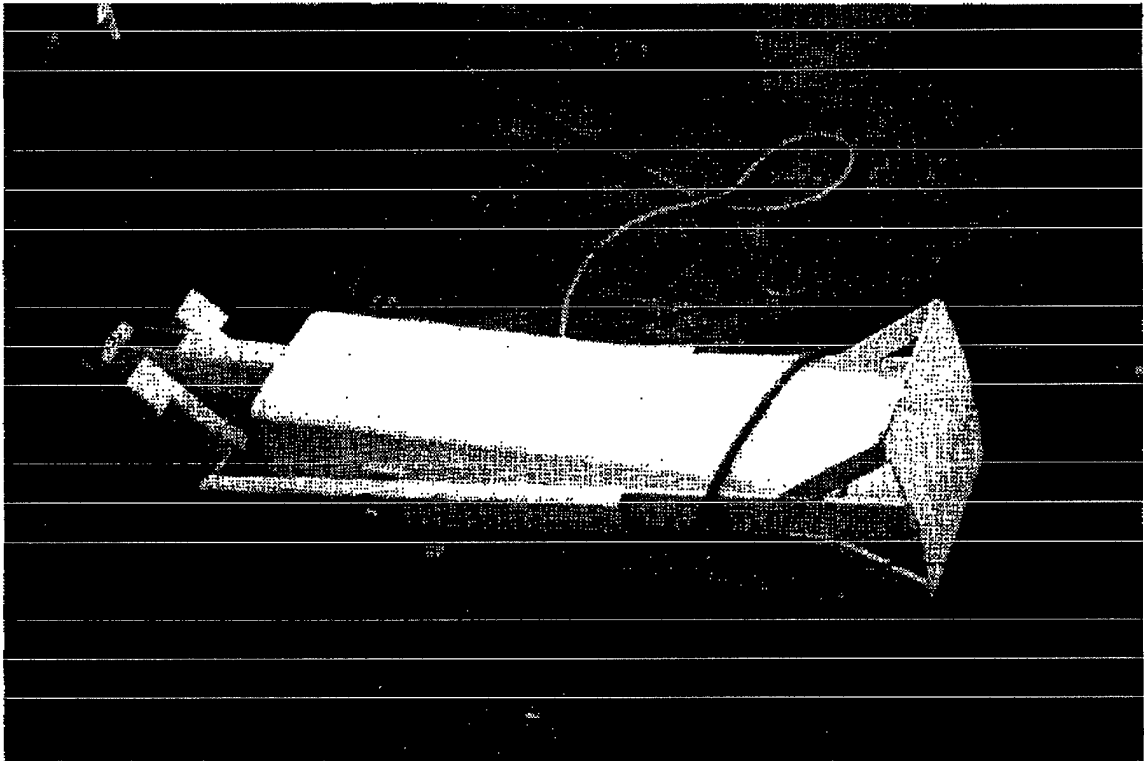

Figure 10. Box corer used to collect BRH sediment samples for preparation of a composite sample. The cement truck was steam cleaned, further cleaned by tumbling clean sand, and rinsed before mixing began. Immediately before sediment was to be placed into the cement truck, air was displaced from inside the mixer with nitrogen gas. All of the sediment from each of the 25 drums was then placed into the cement truck. The mixer was turned on, and the sediments were mixed for 30 min. The composite sample was subsequently poured back into washed drums and distributed to the various investigators for their studies.

Laboratory Procedures

Effluent water quality

42. Modified elutriate test procedure. The modified elutriate test procedure (Figure 11) was conducted on the sediment samples using the procedure described in Palermo (1985). The test procedure consisted of the following steps:

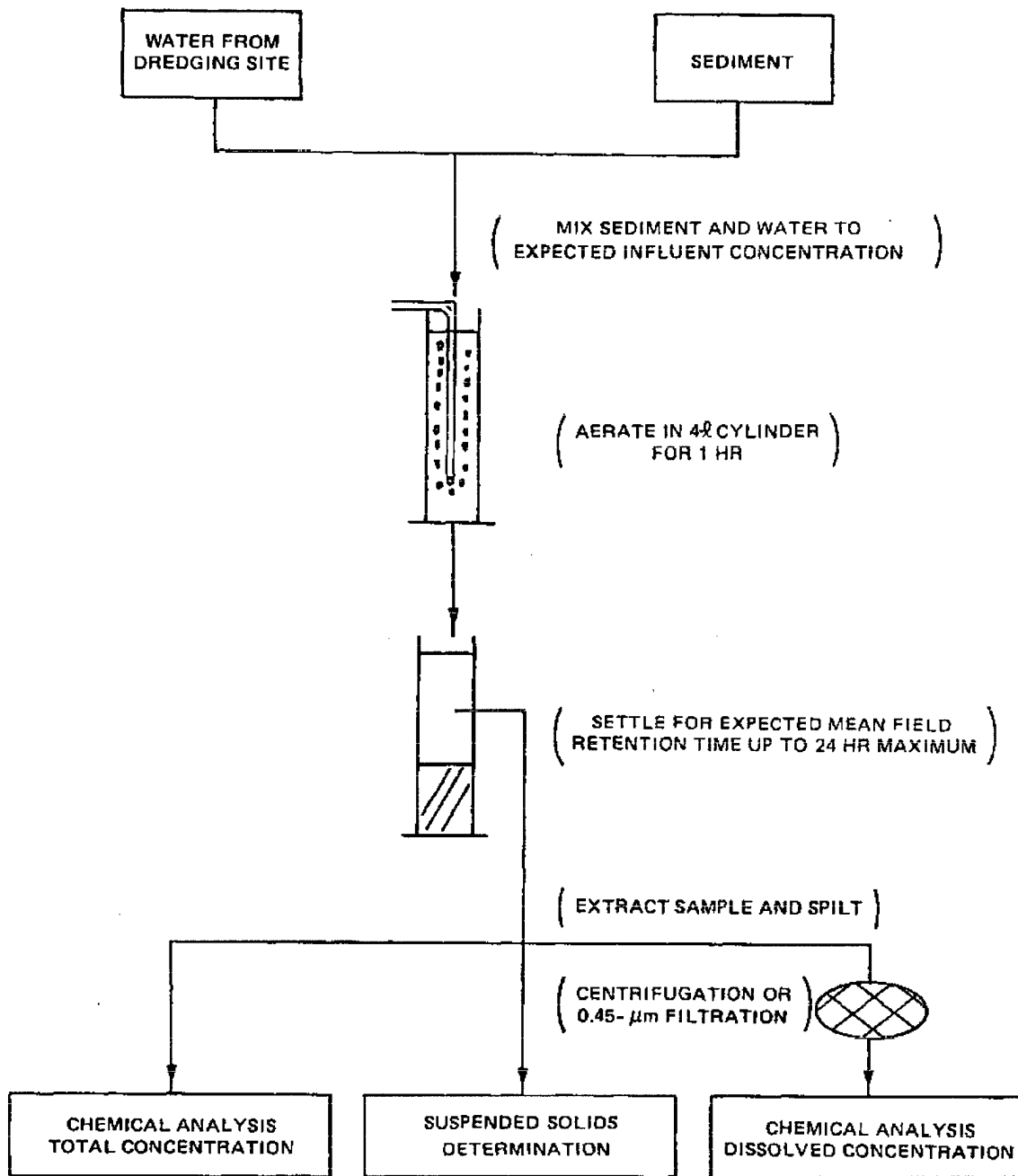

Figure 11. Modified elutriate test procedure

- a. Mixing dredging site sediment and water to a concentration to be expected in the influent.
- b. Aerating to simulate the oxidizing conditions present at the disposal site.
- c. Settling for a time equivalent to the mean retention time at the disposal site.

- d. Extracting a sample of the supernatant water for analysis of dissolved and total contaminant concentrations.

43. The influent solids concentration and field retention time must be known or assumed prior to conducting the modified elutriate tests. For the evaluations conducted for this study, the modified elutriate test procedure was performed after the field monitoring and sample collection at the site. In this way, field data on influent solids concentration and mean retention time were available prior to the test and were used in setting the test factors. Therefore, the comparisons of laboratory predictions and measured field data described in Part V were not biased due to a poor selection of test factors.

44. The field influent solids concentrations were determined from influent samples taken as described in the following paragraphs. The average influent concentration was used as a target concentration in making up the slurry for conducting the modified elutriate test procedure. Slurry concentrations in the laboratory can fluctuate with small variations in sediment sample water content. For this reason, the slurry concentration for the procedure varied somewhat from the target concentration. The field influent concentration (target concentration) was 61 g/l, and the influent laboratory slurry concentration for the modified elutriate tests was 60 g/l.

45. As described in Field Procedures (paragraphs 60-71), the mean field retention time was determined by dye tracer test to be 8 hr. This was the retention time used for the modified elutriate tests.

46. The modified elutriate test procedure was repeated 10 times for prediction of all parameters except PCBs, for which this test was replicated three times. EC, dissolved oxygen (DO) concentration, and pH were measured in the laboratory. All measurements were taken immediately after sample extraction.

47. All chemical analyses for the modified elutriate test procedure and field samples taken in this study were conducted according to standard procedures (American Public Health Association (APHA) 1981; USEPA 1974a and 1974b). The samples were analyzed for total phosphorus, ammonia and nitrate nitrogen, total organic carbon, total PCBs, chromium, copper, iron, lead, manganese, and nickel.

48. The chemical analysis of the modified elutriate samples provided dissolved and total concentrations of parameters in milligrams per litre, and

the TSS concentration was also determined. To predict the total concentration in the effluent, it was necessary to first calculate the fraction of the contaminants associated with the TSS in the elutriate sample. This fraction was calculated as follows:

$$F_{SS} = (1 \times 10^6) \frac{C_{total} - C_{diss}}{SS} \quad (1)$$

where

- F_{SS} = fraction of contaminant in the TSS, mg contaminant/kg of SS
 (1×10^6) = conversion factor, mg/mg to mg/kg
 C_{total} = total concentration, mg contaminant/l of sample
 C_{diss} = dissolved concentration, mg contaminant/l of sample

Results for the modified elutriate dissolved concentrations and calculated fractions in the TSS are summarized for each site in Table 1.

49. Column settling test procedure. The column settling test procedure (Palermo 1985) was used to predict the concentration of SS in the effluent. The test procedure basically consists of the following steps:

- a. Mixing sediment and water to a slurry concentration expected in the influent.
- b. Placing the slurry into a 20.32-cm-diam settling column (Figure 12) and allowing it to settle.
- c. Sampling at several times the supernatant water above the sediment water interface.
- d. Determining the concentration of SS in the supernatant water.

50. As with the modified elutriate test procedure, the field influent concentration of 61 mg/l was used as a target concentration. The actual test slurry concentration for the column test was 57 g/l.

51. Based on results of the column settling test procedure, the effluent SS concentrations could be predicted. The prediction was made using the following steps (Palermo 1985):

- a. Determine the relationship between SS concentration in the supernatant water and settling time from the column test procedure.
- b. From a, select the SS concentration that corresponds to the expected mean field retention time.

Table 1
Summary of Results from Modified Elutriate Test and
Predicted Total Concentrations of Contaminants

Variable*	Modified Elutriate Results		Predicted Total Concentration mg/l
	Dissolved Concentration mg/l	Fraction of TSS mg/kg SS	
Conductivity, mmhos/cm	28,800 ± 185	---	---
Dissolved oxygen	5.03 ± 0.998	---	---
pH	7.5 ± 0.34	---	---
Total phosphorus	0.23 ± 0.085	9,010 ± 3,710	2.18 ± 0.763
Ammonia nitrogen	31.6 ± 0.538	8,740 ± 11,600	33.5 ± 2.07
Nitrate nitrogen	0.034 ± 0.00557	---	---
Total organic carbon	20.5 ± 0.517	218,000 ± 8,480	67.7 ± 18.3
Chromium	0.0027 ± 0.0019	1,770 ± 327	0.386 ± 0.0715
Copper	0.006 ± 0.0040	2,830 ± 605	0.618 ± 0.139
Iron	0.034 ± 0.0083	66,000 ± 9,820	14.3 ± 2.12
Lead	0.0026 ± 0.0015	2,410 ± 1,910	0.524 ± 0.414
Manganese	0.25 ± 0.017	667 ± 490	0.390 ± 0.099
Nickel	0.051 ± 0.066	441 ± 699	0.146 ± 0.149
Total PCB	0.0013 ± 0.0004	56.1 ± 49.2	0.0134 ± 0.0105

* n = 10 for physicochemical variables, nutrients, and metals; n = 3 for PCB.

c. Determine the predicted SS concentration in the effluent by adjusting the column value for wind and turbulence under field settling conditions using a resuspension factor.

52. A predicted value of 216 mg/l for the effluent SS concentration was determined from the column settling test results. This value was used in conjunction with the elutriate data to predict total concentrations of contaminants in the effluent.

53. The total concentrations are the sum of the dissolved concentrations and the particle-associated concentrations. Dissolved concentrations were determined directly by the modified elutriate test procedure. Particle-associated concentrations were calculated using the contaminant fractions of

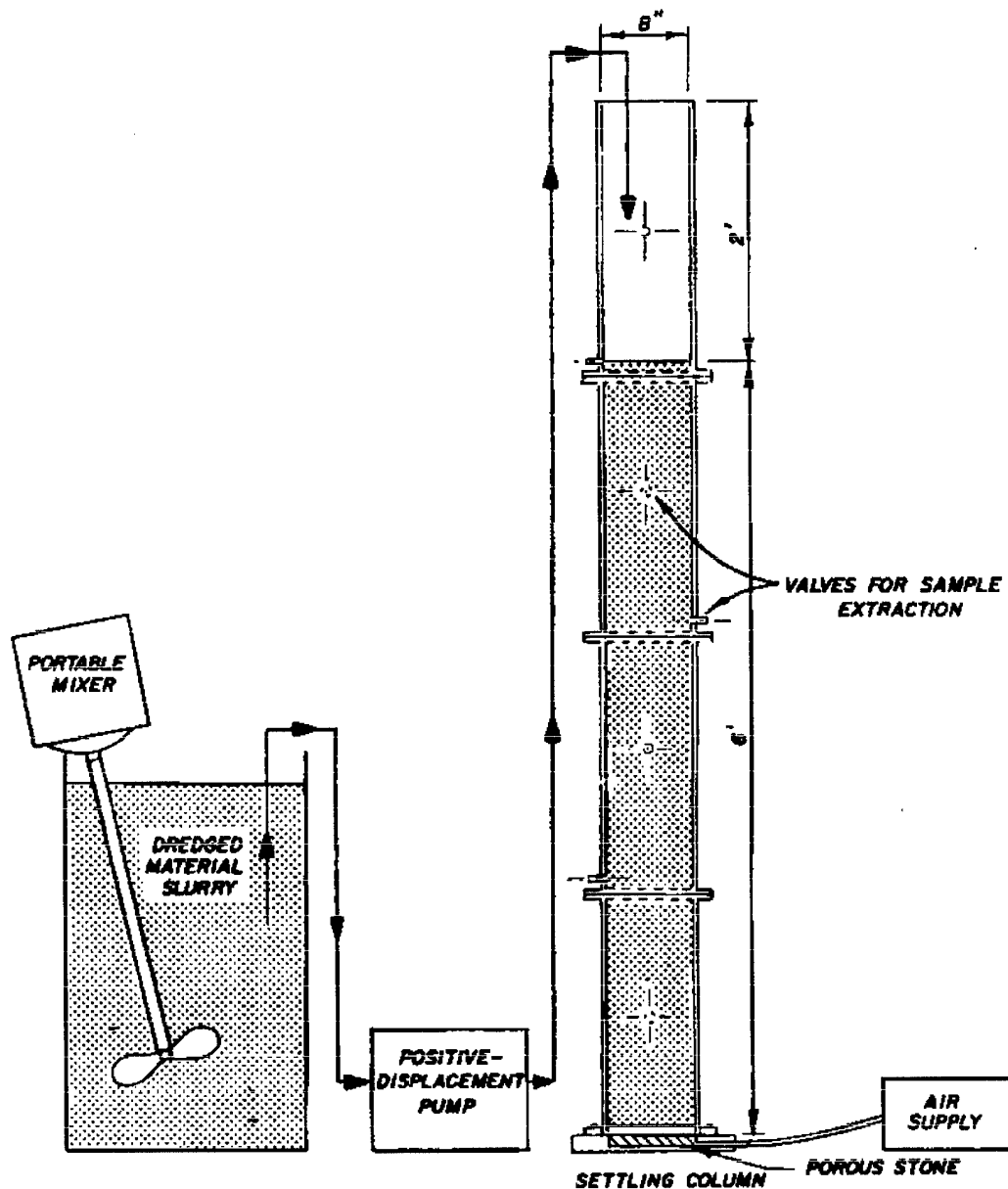

Figure 12. Schematic of apparatus for column settling test (Montgomery 1979)

the TSS (determined in the modified elutriate test procedure) and the predicted effluent SS concentrations (determined in the column settling test procedure). Based on these test results, the total contaminant concentration (milligrams per litre) in the effluent was predicted to be:

$$C(\text{total}) = C(\text{diss}) + \frac{F(\text{SS}) \text{ SS}(\text{eff})}{1,000,000} \quad (2)$$

where

C(total) = estimated total concentration in effluent, mg contaminant/ℓ of water

C(diss) = dissolved concentration determined by modified elutriate test procedure, mg contaminant/ℓ of sample

F(SS) = fraction of contaminant in the TSS calculated from modified elutriate results, mg contaminant/kg of SS

SS(eff) = predicted SS concentration of effluent estimated from evaluation of sedimentation performance, mg SS/ℓ of water

1,000,000 = conversion factor, mg/mg to mg/kg

The results are summarized in Table 1.

Surface runoff water quality

54. The surface runoff water quality test procedure was initiated immediately after placing the composited BRH sediment in laboratory lysimeters (Figure 13). A 5-cm/hr-intensity storm event was applied to each lysimeter for 30 min. This intensity was selected because it was the standard storm intensity used for calibrating the rainfall simulator (Westerdahl and Skogerboe 1982) and has been used as a standard storm event for comparison with natural storm events (Laws and Parsons 1943). Similar rainfall intensities were also used in rainfall simulations for development of the Universal Soil Loss Equation (Wischmeier and Mannering 1969) and soil erosivity nomograph (Wischmeier, Johnson, and Cross 1971).

55. While 5 cm/hr for 30 min may be uncommon in different areas of the country, an intensity of 5 cm/hr for brief periods is not. In addition, it is the less common, high-intensity, high-volume storm events that contribute most to excessive erosion and surface runoff water quality problems. A single intensity and duration storm event was also selected to provide standardization and continuity to facilitate data analysis and comparisons of other future sites.

56. Simulated rainfall was acidified with sulfuric acid to a pH of 4.0 to 4.5, which was the average pH of rainfall for the Bridgeport area (US Department of Energy 1983). One lysimeter was used for the initial BRH sediment, and two lysimeters were used for dredged material collected from the FVP upland disposal site.

57. Surface runoff from the laboratory lysimeter test procedure was collected in a graduated cylinder once every minute for a duration of 10 sec, and the hydrograph was calculated. Runoff samples were collected periodically

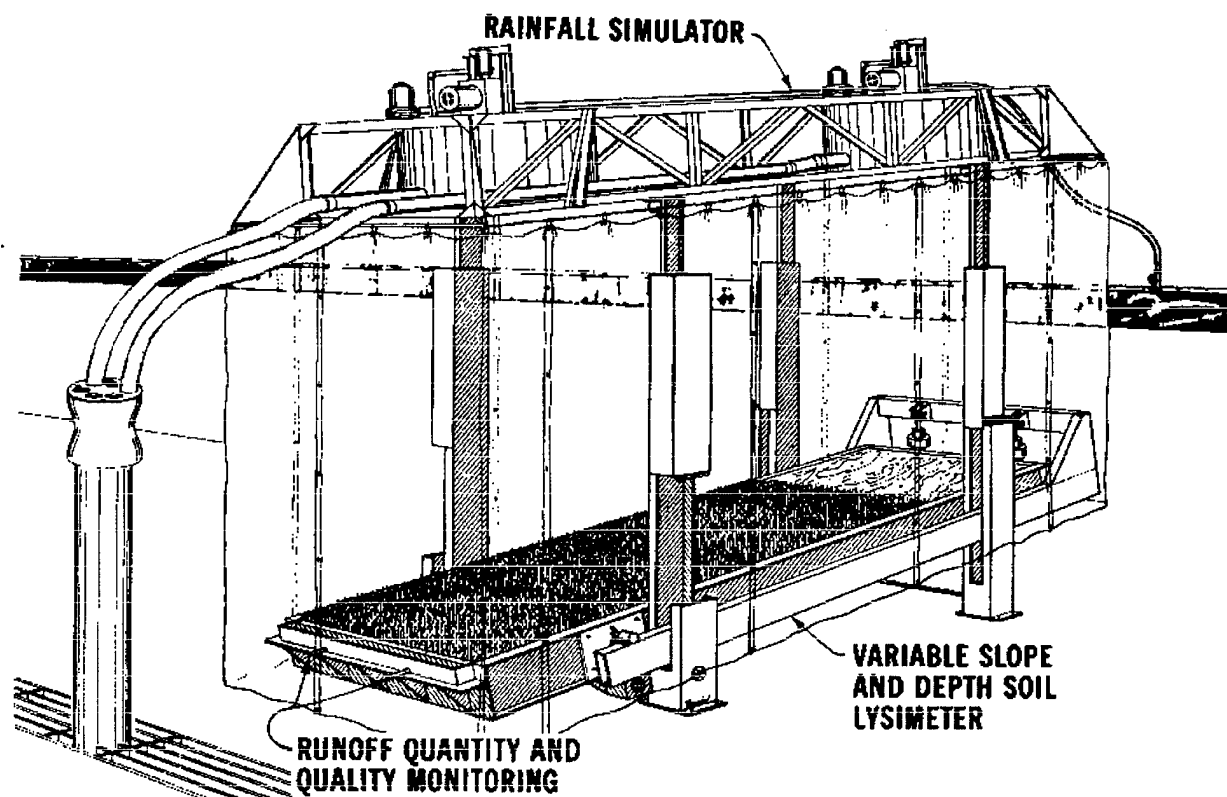

Figure 13. Schematic of the WES rainfall simulator-lysimeter system

in polyethylene bottles throughout the storm event. Samples to be analyzed for PCBs and polyaromatic hydrocarbons (PAHs) were collected once in glass bottles midway through the storm event. Samples were analyzed for EC, SS, cadmium, copper, chromium, manganese, zinc, nickel, lead, mercury, arsenic, O&G, PCBs, and PAHs.

Plant bioassay

58. The plant bioassay was conducted in an experimental unit (EU) similar to that by Folsom and Lee (1981b) (Figure 14). Previous studies (Folsom 1982a and 1982b) had indicated that removal of salt was necessary for plant survival and subsequent growth. Therefore, the upland condition was prepared by washing 1 vol (1 l) of subsamples of the flooded composited BRH sediment with 3 vol (3 l) of reverse osmosis (RO) purified water. An electric stirrer was used to mix the sediment with the water. The SS were allowed to settle (ca. 4 days), at which time the supernatant was removed by siphoning. The sediment was washed two additional times using the above procedure. The washed sediment was subsequently air-dried under greenhouse conditions

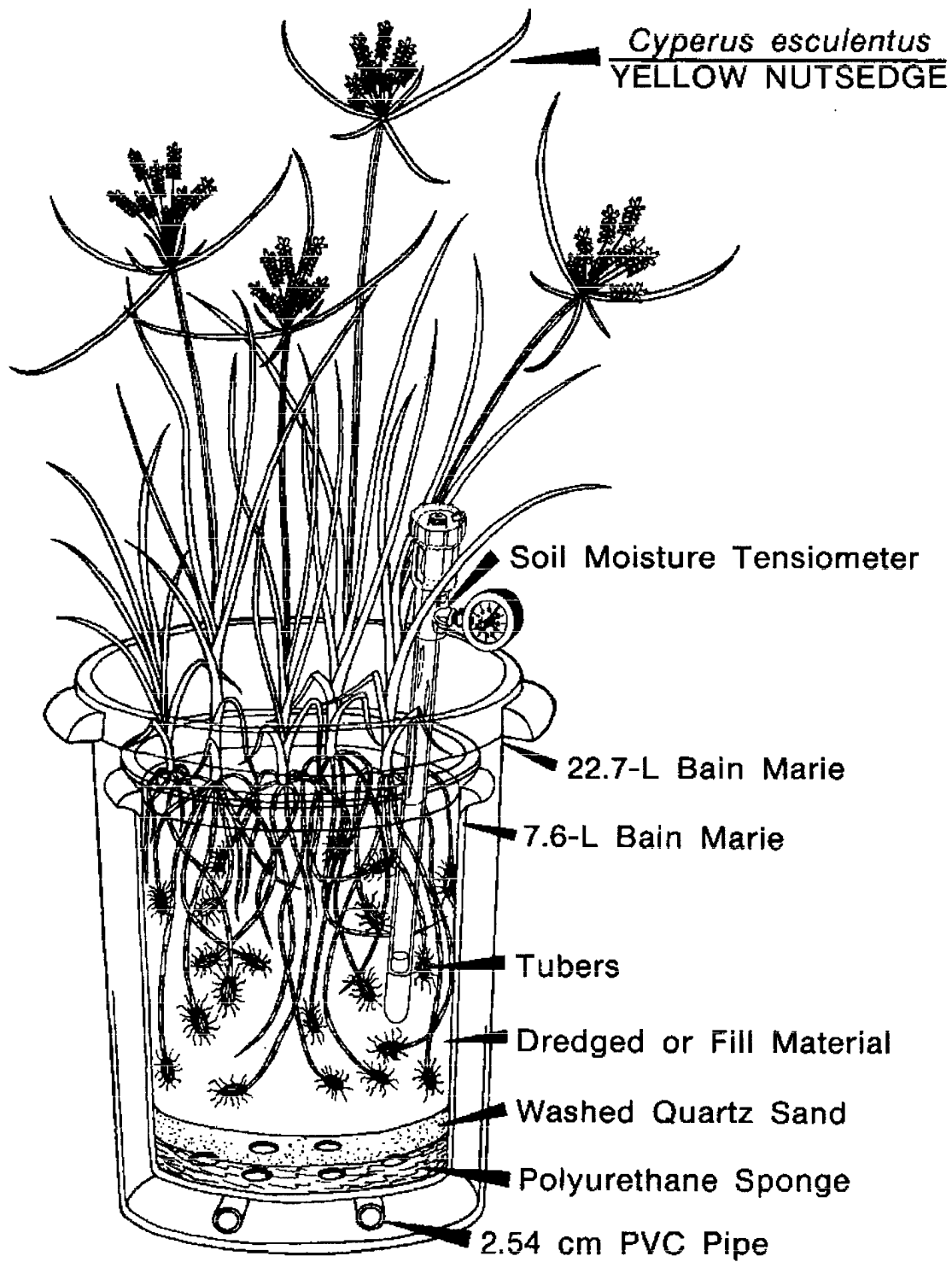

Figure 14. Schematic diagram of the plant bioassay apparatus used in the study

(32.2° C for 16 hr of daylight and at 21.1° C for 8 hr of darkness). Lime was added to achieve a pH of 7.0, and the washed, air-dried (upland) sediment to be tested was placed into the inner container of the EU. The air-dried sediment was initially watered to moisten the sediment and to promote seedling growth. The procedure of Folsom and Lee (1981b) was then followed with the exception that *S. alterniflora* and *S. virginicus* were grown as index plants. The sediment was analyzed for texture, organic matter (OM), EC, calcium carbonate equivalent (OCE), lime requirement, pH, total sulfur (TS), O&G, and heavy metals (total nitric acid digestible and DTPA extractable).

Animal bioassay

59. The WES earthworm bioassay procedure of Rhett, Simmers, and Lee (1986) was applied to subsamples of the composited BRH sediment. In the initial tests, in order to simulate salt leaching due to natural rainfall and to enhance earthworm survivability, the sediment was washed with RO water until the wash water indicated 0-ppt salt as measured by a temperature compensated refractometer (Model number 10419, American Optical, Buffalo, New York). The sediment was then air-dried, pulverized, and rewet with RO water to field capacity before the animals were added. As used here, field capacity is defined as the maximum amount of water that can be held within the pores of a soil after excess water has drained, usually for 24 hr. Initial screening tests indicated that the BRH sediment was quite toxic to the worms whereas a similarly prepared reference sediment collected at the mouth of BRH was not; BRH reference sediment was material collected from an area of lesser contamination at the mouth of BRH (Simmers et al., in preparation). A series of toxicity tests indicated that survival for 7 days could be obtained only if the BRH sediment was diluted with less contaminated material. A local woodland soil previously described as the WES reference soil (van Driel, Smilde, and van Luit 1985) was chosen as the dilution medium. Mixtures of 10-percent BRH sediment and WES reference soil were used for a 7-day test period. About 40 g (live weight) of earthworms was placed in approximately 1 kg each of the following substrates: 10-percent BRH sediment and 90-percent WES reference soil; 100-percent BRH reference sediment and 100-percent WES reference soil. The tests were conducted in a controlled-temperature growth chamber at 20° C. No supplemental food was provided during the 7-day test period. A schematic diagram of the EU is shown in Figure 15. Results of the test procedure are reported in Part IV of this report.

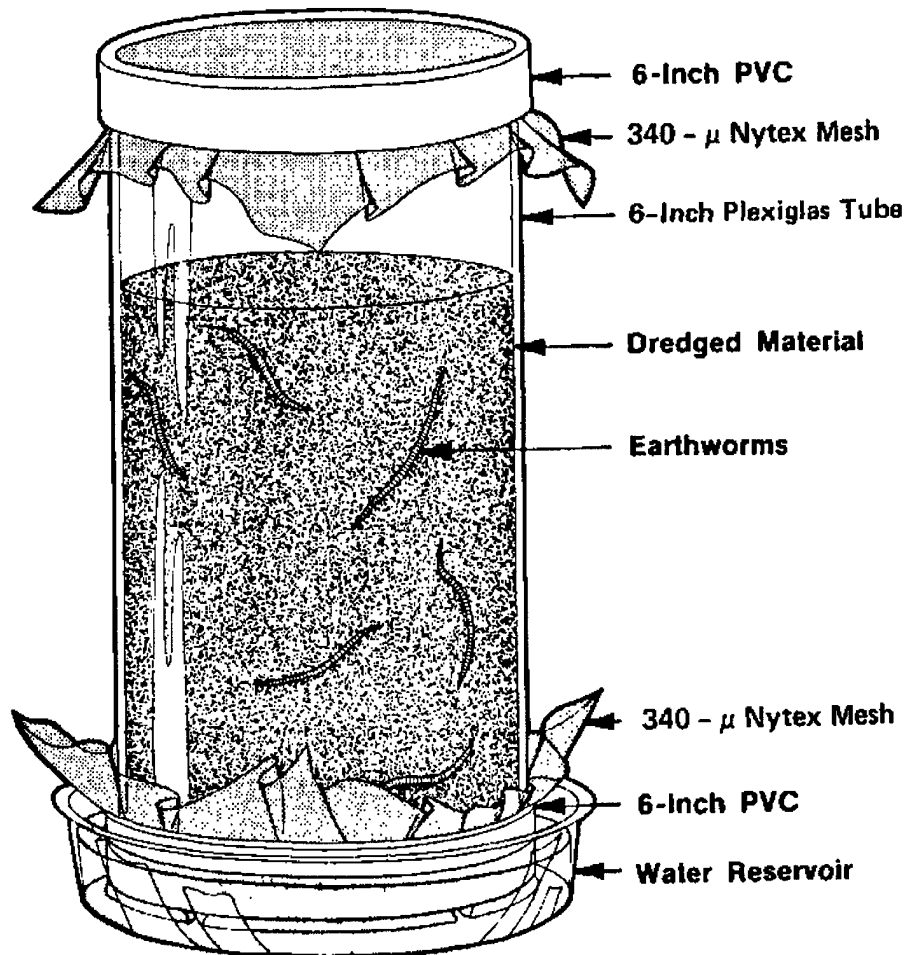

Figure 15. Schematic diagram of the animal bioassay apparatus used in the study*

Field Procedures

Effluent water quality

60. The mean retention or residence time for the containment areas was determined by conducting a dye study. Dye was injected at the point of inflow, and dye concentrations of the effluent were determined. Mean retention time was calculated as the centroid of the dye concentration versus time. The data were calculated prior to conducting the modified elutriate test procedure described previously so that the estimated retention time could be used in setting the laboratory retention time for the test procedure. The mean

* To convert inches into centimetres, multiply by 2.54.

retention time was also used with the column settling test results to estimate the concentration of SS in the effluent.

61. Measurements of the ponded water depth were taken to calculate the volume of the ponded water and the required dye volume prior to injecting the dye tracer. Rhodamine WT dye was used as a tracer. The measured mean retention time during the water quality sampling was approximately 8 hr, but the model value was only about 15 min. The retention time distribution curve is shown in Figure 16.

Influent/effluent sampling

62. Influent and effluent samplings were conducted during a 24-hr time period. Sampling intervals for influent and effluent were based on both operational and financial constraints. Influent samples were taken directly from the pipe discharging into the disposal area. The flow was allowed to fill sample containers. A photograph of the influent sampling point is shown in Figure 17. A total of 23 influent samples were taken on an approximately hourly basis during the 24-hr water quality sampling period.

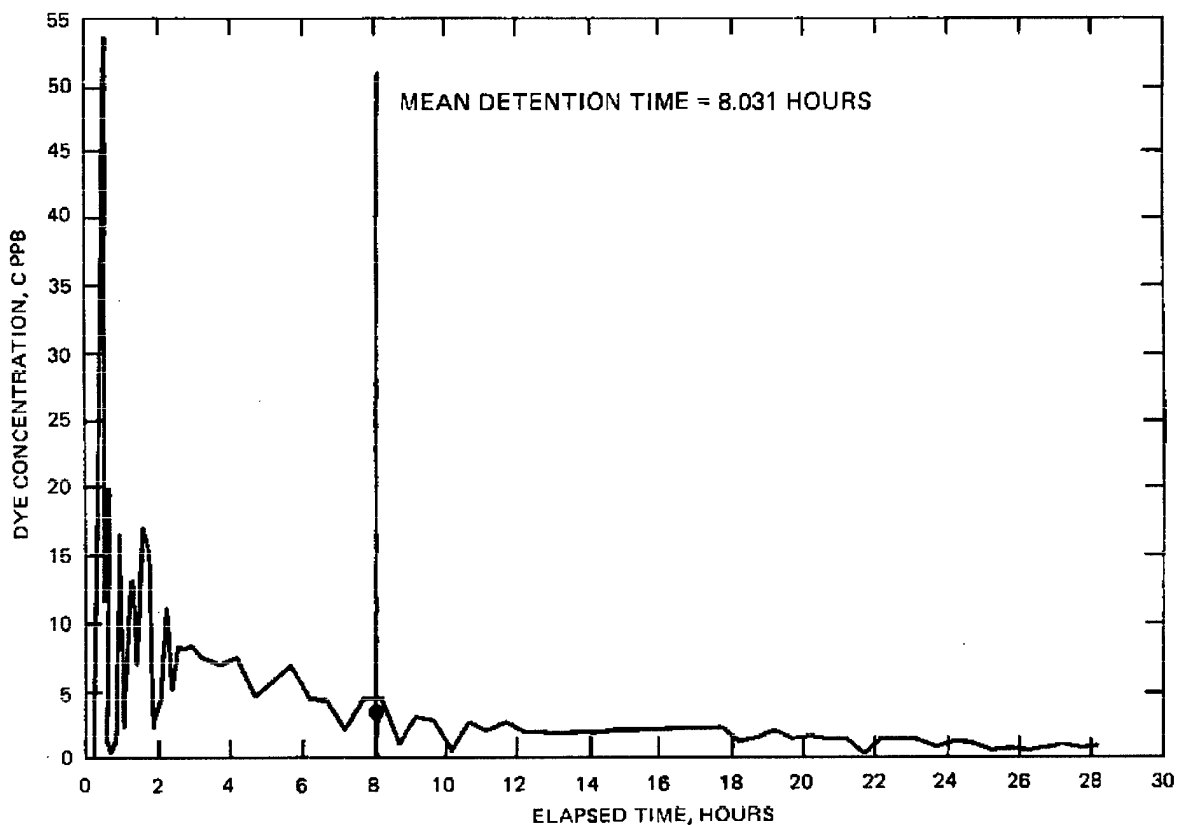

Figure 16. Dye tracer curve for FVP upland site



Figure 17. Influent pipe

63. Effluent samples were taken at the overflow weir. The effluent samples were taken by allowing the weir overflow to fill sample containers. A photograph of the effluent sampling point is shown in Figure 18. A total of 48 effluent samples were taken approximately every half hour during the 24-hr water quality sampling period.

64. The influent and effluent samples were immediately placed in ice chests and maintained at 4° C during transport to the WES for processing and analysis. DO, pH, and EC were determined on each sample while in the field.



Figure 18. Effluent pipe

65. The influent and effluent samples were analyzed for total organic carbon, ammonia and nitrate nitrogen, total phosphorus, arsenic, cadmium, chromium, copper, iron, lead, mercury, manganese, nickel, zinc, and total PCBs. Concentration of dissolved contaminants was obtained by analyzing the filtrate from a 0.45- μ m millipore filter or by equivalent centrifugation. Total concentration of contaminants was determined on unfiltered samples.

66. Since total concentrations of contaminants were determined in both influent and effluent at both sites, the retention percentage of contaminants could be calculated. Retention of contaminants within the disposal area was determined from the influent and effluent concentrations as follows:

$$R = \frac{[C(\text{in})] - [C(\text{eff})] (100)}{[C(\text{in})]} \quad (3)$$

where

R = retention in percent

[C(in)] = total concentration in influent, mg/l

[C(eff)] = total concentration in effluent, mg/l

Surface runoff water quality

67. The laboratory surface runoff water quality test procedure was field verified by establishing three plots in the FVP upland field site identical in size to the laboratory soil bed lysimeters (4.57 by 1.22 m). Aluminum boxes were constructed at the WES, assembled in the field, and placed over the plots (Figure 19). The sides were 1.83 m high and were constructed for easy removal of side plates in 15-cm increments as the dredged material consolidated. The boxes were constructed and lowered into the dredged material at or near the point where dredged material had been collected for the laboratory lysimeter tests.

68. Procedures for determining runoff rates and collecting samples in the field were identical to those used on the laboratory lysimeters. Field-collected samples, however, were analyzed for only SS, pH, conductivity, copper, cadmium, chromium, manganese, zinc, and nickel. Initial laboratory testing showed that other variables would be less than detectable limits in filtered samples and thus would provide very little useful information toward field verification of the laboratory lysimeter tests.

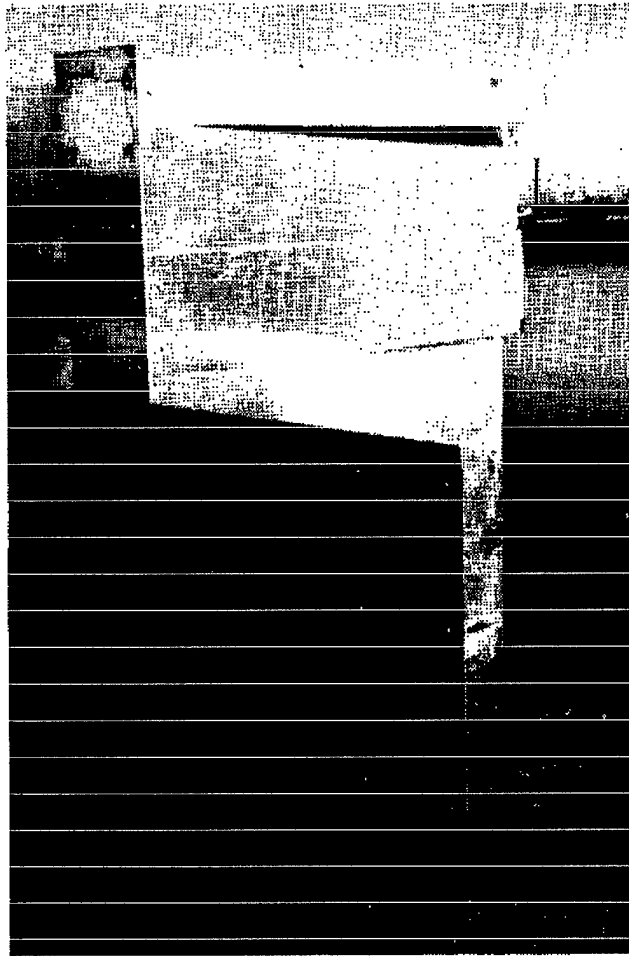

Figure 19. Construction of field rainfall simulator plots

Statistical analysis

69. The two sources of variation were treatment (lysimeter or field) and error. The null hypothesis was that lysimeter concentrations equaled field concentrations, and the alternate was that lysimeter concentrations were not equal to field concentrations. These hypotheses were separately applied to filtered and unfiltered samples. Rejection of the null hypothesis indicated that the lysimeter test did not accurately predict the field results.

70. One-sided T-tests* of significance were used to compare lysimeter runoff concentrations with USEPA Maximum Criteria for the Protection of

* The T-test and tests of significance have $P = 0.05$ of a type I error unless otherwise stated. Because the most likely receiving area for discharged surface runoff was some type of aquatic environment, the USEPA Maximum Criteria for the Protection of Aquatic Life were selected as the criteria for comparison with surface runoff (Lee et al. 1985).

Aquatic Life. The USEPA values were substituted for the specific comparison. The null hypothesis was that lysimeter runoff concentrations were greater than the USEPA Criteria. The alternate hypothesis was that lysimeter concentrations were less than the USEPA Criteria. In cases where the USEPA Criteria were a range, the lower limit was used. Rejection of the null hypothesis indicated that no restrictions should be placed on surface runoff.

Site Management for Controlling Surface Runoff Water Quality

Plot establishment

71. Several soil amendments were selected for testing at the site based on recommendations contained in an Instruction Report by Lee et al. (1985). They were: (a) control, no amendments; (b) agricultural lime at 28.2 Mt/ha; (c) agricultural lime at 28.2 Mt/ha plus a 13-cm surface layer of sand plus a 6.6-cm surface layer of limestone gravel; (d) agricultural lime at 28.2 Mt/ha plus horse manure at 112 Mt/ha; and (e) agricultural lime at 28.2 Mt/ha plus a 13-cm surface layer of sand plus a 6.6-cm surface layer of limestone gravel. The purpose of the agricultural lime was to raise the soil pH to between 6.0 and 7.0 to allow vegetation to grow and to reduce soluble heavy metals. Sand was collected from the upland disposal site near the influent point. The purpose of the sand and gravel was to provide a layer of relatively uncontaminated nonsaline material to allow plant rooting and growth before contacting the dredge material. Horse manure was also used to improve the rooting and growing medium for the vegetation and to reduce soluble heavy metals.

72. Three plant species selected (Lee et al. 1985) and the upland estuarine plant of the WES plant bioassay were tested on the field site. The plant species were selected on the basis of salt tolerance and included: *Agropyron elongatum* (tall wheatgrass, variant "Alkar"), *Festuca arundinacea* (tall fescue, var. "Alta"), *Puccinellia distans*, and *S. virginicus*.

73. The test plots were established on the FVP upland field site approximately 1 year after the dredged material had been placed in the site. A 10.16- to 15.2-cm crust had formed on the surface of the material, and extensive cracking had occurred. Dredged material under the crust layer was still very soft and gelatinous so that incorporating the soil amendments into the material was impossible. Therefore, the soil amendments were broadcast

over the surface of the dredged material and into the cracks. Each plot was subdivided into four sections, and each was planted with one of the plant species. *Agropyron elongatum*, *F. arundinacea*, and *P. distans* were planted by broadcast seeding while *S. virginicus* was transplanted using vegetative plugs.

Surface runoff water quality tests

74. Approximately 1 year after the vegetative plots were established, surface runoff water quality tests were conducted on three treatments and one plant species. The treatments were (a) the control, (b) agricultural lime plus sand plus limestone gravel, and (c) agricultural lime plus sand plus limestone gravel plus horse manure; the plant species was *A. elongatum*. These three treatments were selected from the total of five treatments because under time and budget constraints they would provide the most information on the effectiveness of soil amendments for controlling surface runoff water quality. Vegetation was established only on plots amended with horse manure. *Agropyron elongatum* was selected for the runoff water quality work because of its superior growth compared with the others.

75. Rainfall simulations and sampling were conducted in an identical manner as the greenhouse lysimeter and the field verification tests. Surface runoff water samples were analyzed for SS, pH, filtered (dissolved) and unfiltered (total) cadmium, copper, manganese, nickel, zinc, and chromium.

Plant bioassay

76. A plant bioassay was conducted in situ 8 months after filling of the site. The site had not yet completely physically stabilized. However, a drainage-drying gradient had developed from the upper end of the site near the inlet pipe (almost dry) to almost saturated in front of the weirs. The upper end of the site had drained sufficiently to allow a 4-cm crust to form; midway between the upper end and the weir, only a 1-cm crust had formed, and no crust existed in front of the weir. A series of in situ EUs were established in those three areas. The procedure was to excavate the dredged material, place the material from the excavation into the inner container of the EU, and then place the EU into the excavation. The upland site was also used to field verify rainfall-surface runoff studies. Research conducted under the Environmental Impact and Research Program (EIRP) indicated that a combination of four treatments would minimize contaminant mobility in runoff from the site. These treatments included addition of lime, manure, sand, and gravel to the dredged material before being planted with the index plants. Therefore, the in situ

treatments were prepared by mixing the appropriate material with the dredged material from each excavation before placement of the EU. In addition to the estuarine index plants, *S. alterniflora* and *S. virginicus*, two other species were planted in each EU. These species had been used in prior runoff studies conducted under the EIRP and had shown salt tolerance. They were *Puccinellia distans* and a *Puccinellia* spp. adapted to high-salinity environments along highways in northern Illinois, where salt is used to melt road ice. EUs containing the four species were also planted in situ in a controlled background area located near the site.

Animal bioassay

77. The initial approach employed in the field test of the animal bioassay procedure was the placement of laboratory EUs in the field along either side of the bridge (the bridge can be seen in Figure 4). The earthworms died during the test. So following recommendations from the Animal Bioassay Working Group* in 1984, 2.5- by 2.5- by 2.5-m Plexiglas containers with perforated-sides (0.5-cm) and open tops were embedded in selected field plots.

78. The field plots selected represented each of the restoration strategies described above. The earthworms also died in these containers. Therefore, further modifications were used to accelerate leaching of salt from the upper layers of the dredged material (i.e., a roto tiller to break up the dredged material). In spite of these modifications, earthworm survival was not increased within the remaining year of testing.

* J. W. Simmers. 1984. "FVP Wetland and Terrestrial Animal Bioassay Update," Information Exchange Bulletin No. D-84-3, US Army Engineer Waterways Experiment Station, Vicksburg, Miss., pp 6-9.

PART IV: LABORATORY AND FIELD TEST RESULTS

Effluent Water Quality

Laboratory

79. Results of the modified elutriate test procedure are summarized in Table 1. The mean DO concentration for the tests was 5.03 mg/l, indicating that oxidizing conditions were present in the supernatant water during the test. Of the 10 metals analyzed, the concentrations of total and dissolved arsenic and mercury and dissolved zinc were below detection limits. These same variables were also below detection in the field samples. The measured dissolved concentrations of cadmium were higher than the measured total concentrations, presumably due to analytical error. Consequently, no comparisons of predicted and field values for cadmium were possible.

80. A predicted value of 216 mg/l for the effluent SS concentration was determined from the column settling test results, and this value was used in conjunction with the elutriate data to predict total concentrations of contaminants in the effluent. These results are also summarized in Table 1.

Field

81. All field results for effluent water quality are summarized in Table 2. Plots of the influent and effluent SS concentrations are shown in Figure 20. The mean concentration of SS in the influent was approximately 61 g/l, while the mean concentration of SS in the effluent was approximately 173 mg/l (Table 2). The site therefore had a solids retention efficiency of approximately 99.7 percent. This high solids retention efficiency shows that the site, though small, was efficient as a settling basin.

82. Conductivity and pH were relatively unchanged (Table 1). Comparison of DO values in the influent and effluent indicates a dramatic rise in DO levels during retention in the pond (Figure 21). Mean influent DO was 0.63 mg/l while mean effluent DO was 5.57 mg/l during the same period. This increase is probably due to turbulence and mixing of influent with air and aerated ponded waters. Wind action can also aid in increasing DO levels in the ponded water. The high effluent DO concentrations indicated that oxidizing conditions were present in the ponded water.

83. Metal concentrations measured in the field samples included arsenic, cadmium, chromium, copper, iron, lead, mercury, manganese, nickel,

Table 2
Summary of Field Results

Variable	Total Concentration, mg/l		R	Dissolved Concentration, mg/l		Fraction of TSS, mg/kg SS†	
	Influent*	Effluent*		Influent*	Effluent*	Influent*	Effluent*
Total suspended solids	60,700 ± 40,000	173 ± 133	99.7	--	--	--	--
Conductivity, mmhos/cm	20,500 ± 1,270	20,300 ± 1,470	--	--	--	--	--
Dissolved oxygen	0.63 ± 0.91	5.57 ± 1.43	--	--	--	--	--
pH	7.2 ± 0.16	7.3 ± 0.065	--	--	--	--	--
Total phosphorus	80.3 ± 95.3	2.92 ± 0.507	--	2.88 ± 34.0	0.96 ± 0.377	1,700 ± 1,710	13,100 ± 4,870
Ammonia nitrogen	73.7 ± 39.4	63.6 ± 3.62	--	66.5 ± 0.119	60.4 ± 4.55	99.5 ± 51.5	23,600 ± 24,500
Nitrate nitrogen	---	--	--	0.104 ± 5.45	0.12 ± 0.133	--	--
Total organic carbon	1.310 ± 1.490	24.4 ± 7.45	--	11.7 ± 0.0016	2.71 ± 1.16	28,600 ± 29,400	96,700 ± 2,420
Arsenic	0.099 ± 0.05	BD	--	BD	BD	--	--
Cadmium	1.34 ± 1.04	0.0102 ± 0.0132	99.2	0.0015 ± 0.0045	0.0046 ± 0.0012	34.5 ± 23.8	21.3 ± 24.6
Chromium	58.4 ± 48.9	0.400 ± 0.393	99.3	0.0104 ± 0.0139	0.0079 ± 0.0047	1,290 ± 986	2,060 ± 703
Copper	38.5 ± 26.2	0.82 ± 0.826	97.9	0.0126 ± 0.618	0.074 ± 0.0362	1,000 ± 880	3,760 ± 1,600
Iron	755 ± 608	8.22 ± 5.55	98.9	2.36 ± 0.0034	0.042 ± 0.0315	6,800 ± 11,700	48,700 ± 14,700
Lead	14.0 ± 11.3	0.31 ± 0.959	97.8	0.007--	0.0100 ± 0.0127	341 ± 299	914 ± 1,880
Mercury	0.023 ± 0.013	BD	--	BD	BD	--	--
Manganese	7.52 ± 5.88	0.36 ± 0.088	95.0	0.36 ± 0.083	0.28 ± 0.0177	152 ± 107	536 ± 237
Nickel	5.01 ± 3.74	0.07 ± 0.063	98.6	0.016 ± 0.008	0.0329 ± 0.014	112 ± 75.4	219 ± 357
Zinc	52.2 ± 62.4	0.39 ± 0.358	99.3	BD	BD	1,020 ± 564	--
Total PCB	17.1** ± 5.97	0.0099 ± 0.0222	99	--	0.0017 ± 0.00094	--	64.2 ± 22.1

* n = 23 for influent and n = 48 for effluent for physicochemical variables, metals, and nutrients.

u = 12 for influent and n = 24 for effluent for PCB.

BD = below detection.

R = Retention efficiency defined as the ratio of total influent concentration minus total effluent concentration to the total influent concentration, expressed as a percentage.

** Total concentration for influent PCB determined on mg/kg basis.

† Fraction of contaminants in SS as defined on page 35.

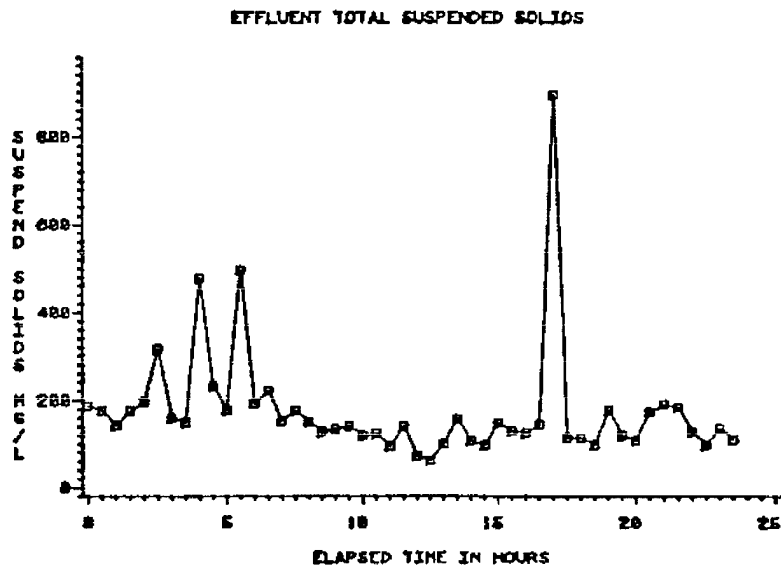
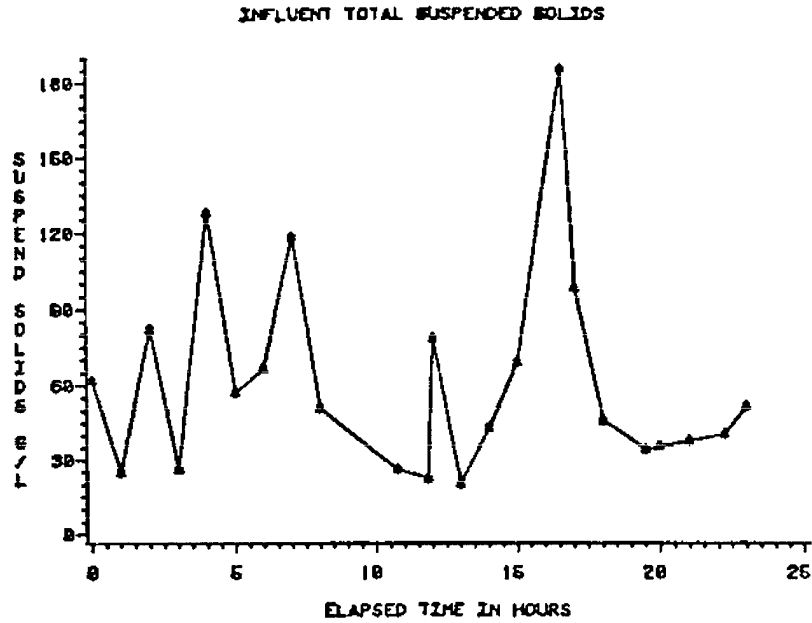

Figure 20. Influent and effluent TSS concentrations

and zinc. Dissolved concentrations of mercury, arsenic, and zinc were at or below detection limits. The trends for copper are shown in Figure 22. These data are typical of the metals results. The total concentration of all metals showed dramatic reductions for effluent concentrations as compared with influent concentrations, indicating a high retention of metals within the disposal area. The average retention of total metals was 98.3 percent. This would be

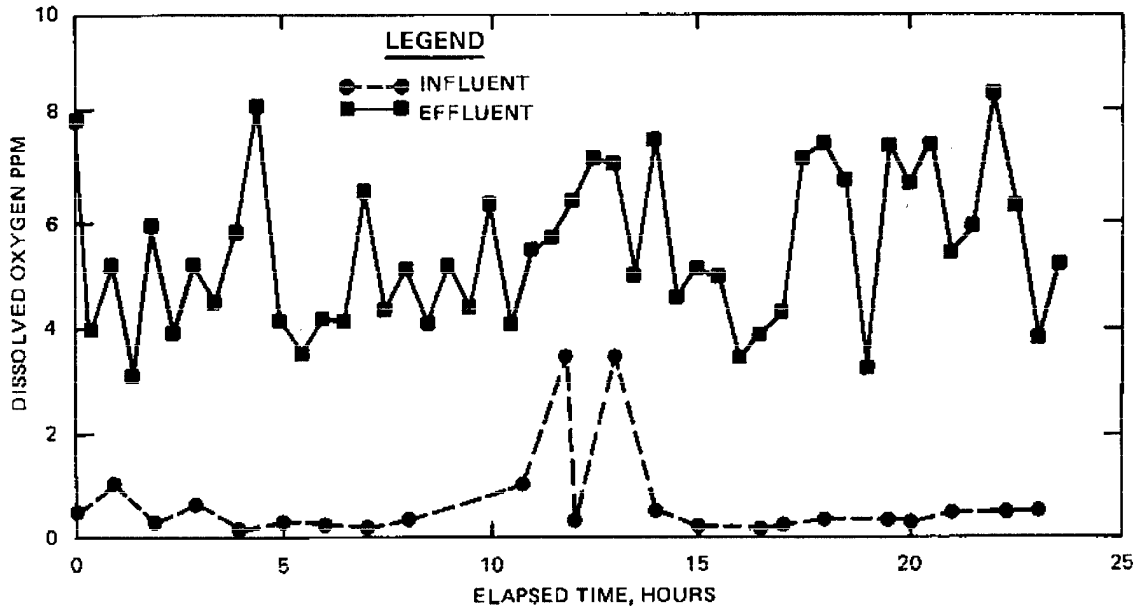

Figure 21. Influent and effluent DO concentrations

expected as heavy metals are strongly associated with suspended particles; excellent retention of particles removed metals through sedimentation. This retention behavior is typical of most confined disposal sites.

84. Metal fractions of the SS were higher in the effluent as compared with influent. This is due to the fact that the effluent particles are smaller in size on the average than influent particles and therefore have a higher retentive (more adsorptive) surface. Such particles have a higher affinity for absorbed contaminants; therefore, the contaminant fractions would be higher.

85. Results for total phosphorus and total organic carbon were generally similar to those for metals, with high retention reflecting retention of solids. Ammonia and nitrate nitrogen reflected little retention due to ponding and sedimentation as these compounds are not tightly bound to sediment particles.

86. The results for PCBs were similar to that of the metals. Total PCB concentrations showed a large net reduction in the effluent as compared with the influent, with a calculated retention in excess of 99 percent. These results were expected since organic contaminants such as PCB normally have a high affinity for suspended particles and there was a significant decrease in suspended particles.

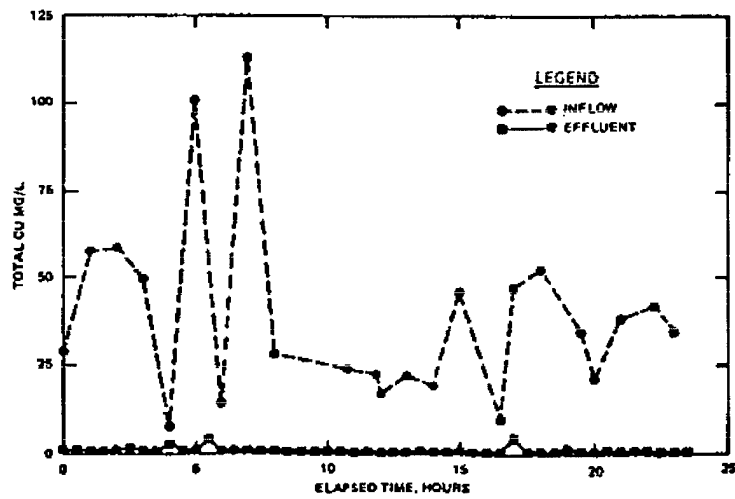
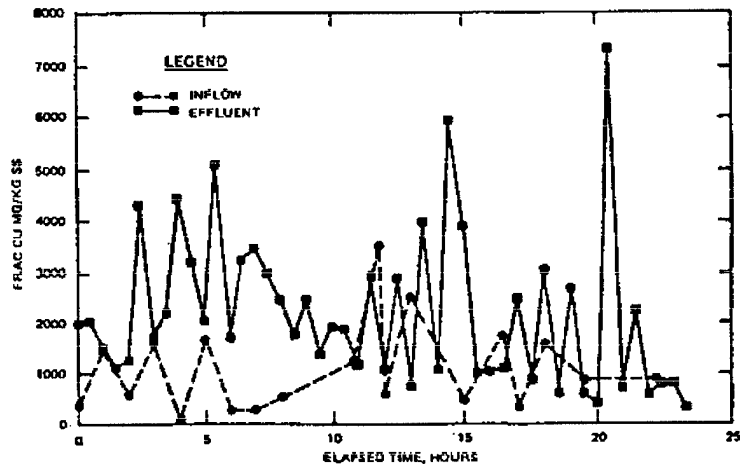
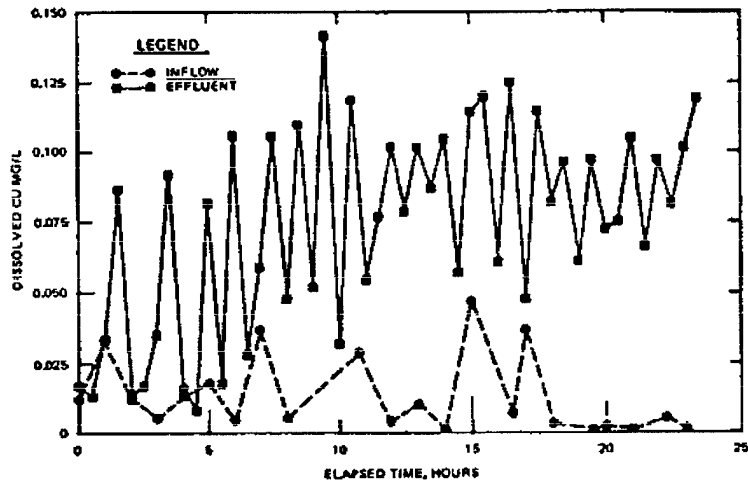

Figure 22. Influent and effluent copper concentrations

Surface Runoff Water Quality

Wet sediment and dredged material

87. Filtered heavy metal concentrations in surface runoff from composited BRH sediment laboratory lysimeters were equal to those of the filtered metal concentrations in surface runoff from the dredged material collected from the site (Table 3). Comparison of results from the laboratory lysimeter test immediately after disposal conducted on the composited sediment with results from field tests conducted at the site showed that the initial moisture content at disposal had no statistically significant effect on the filtered heavy metal concentrations (Table 3) except for chromium. The difference in filtered chromium concentrations, however, was small--less than an order of magnitude.

88. Unfiltered heavy metal concentrations from the composited BRH sediment used in the laboratory lysimeter tests were statistically greater than unfiltered concentrations from the laboratory lysimeter and field tests using dredged material from the FVP upland site. Unfiltered metal concentrations from the BRH upland field site were not statistically different from the laboratory lysimeter filled with the same dredged material. Differences in collection and disposal methods between the composited BRH sediment and the subsequent BRH dredged material therefore did have a significant effect on unfiltered (total heavy metal) concentrations. These differences, however, were small, less than an order of magnitude.

Dry sediment and dredged material

89. Comparison of surface runoff water quality results from the two lysimeter tests and the field test on dry, oxidized sediment and dredged material showed no statistical differences from either the unfiltered or filtered heavy metal data (Table 4). Small differences in total heavy metal concentrations that occurred in surface runoff from the wet, anaerobic condition were not observed after the materials had dried and oxidized. Both laboratory lysimeter tests predicted the physicochemical changes that occurred when the dredged material was placed in the actual confined upland disposal site. Filtered concentrations of copper, manganese, zinc, nickel, and chromium from both of the laboratory tests were not statistically different from concentrations in the field tests. Both laboratory lysimeter tests, however, overestimated the filtered concentration of cadmium. The laboratory lysimeter tests

Table 3
Surface Runoff Water Quality from Wet
Sediment and Dredged Material

Parameter	Initial Sediment Lysimeter	Dredged Material Lysimeter	Dredged Material Field
SS, mg/ℓ	2,296 a*	10,326 ± 5,040 a	9,247 ± 6,049 a
pH	7.6 a	7.8 ± 0.07 a	7.5 ± 0.18 a
Conductivity, mmhos/cm	7.3 a	10.5 ± 1.02 a	6.7 ± 0.98 a
<u>Unfiltered Heavy Metals, mg/ℓ</u>			
Cd	1.172 ± 0.210 a	0.328 ± 0.104 b	0.218 ± 0.173 b
Cu	102 ± 19.9 a	34.6 ± 15.2 b	24.5 ± 17.3 b
Mn	11.5 ± 2.30 a	3.83 ± 1.51 b	2.61 ± 1.73 b
Ni	6.48 ± 1.32 a	2.04 ± 0.965 b	1.63 ± 1.02 b
Zn	53.7 ± 10.6 a	16.0 ± 7.08 b	16.1 ± 11.4 b
Cr	61.2 ± 13.7 a	19.3 ± 8.87 b	15.7 ± 8.57 b
<u>Filtered Heavy Metals, mg/ℓ</u>			
Cd	0.005 ± 0.002 a	0.005 ± 0.002 a	0.0004 ± 0.0002 b
Cu	0.058 ± 0.010 a	0.011 ± 0.005 a	0.008 ± 0.012 a
Mn	0.022 ± 0.009 a	0.112 ± 0.026 a	0.102 ± 0.034 a
Ni	0.021 ± 0.005 a	0.013 ± 0.012 a	0.012 ± 0.005 a
Zn	0.05 ± 0.003 a	0.120 ± 0.087 a	0.081 ± 0.036 a
Cr	0.014 ± 0.004 a	0.004 ± 0.001 b	0.002 ± 0.002 b

* Concentrations from different tests followed by the same letter are not statistically different at P = 0.05 .

did predict the increased solubilities of cadmium, copper, manganese, zinc, and nickel as well as the continued poor solubility of chromium, which was verified at the FVP field site. Surface runoff pH was statistically lower in runoff samples from the field site than either of the two laboratory lysimeter tests.

90. Comparison of the filtered heavy metal concentrations from the dry, oxidized material with the USEPA Maximum Criteria for the Protection of Aquatic Life showed that the criteria were exceeded by cadmium, copper, and zinc (Table 5). Filtered concentrations of cadmium and zinc exceeded the criteria by an order of magnitude, and copper exceeded the criteria by two orders of magnitude.

Table 4
Surface Runoff Water Quality from Dry, Oxidized Sediment
and Dredged Material

<u>Parameter</u>	<u>Initial Sediment Lysimeter</u>	<u>Dredged Material Lysimeter</u>	<u>Dredged Material Field</u>
SS, mg/l	320 a*	167 ± 41 a	151 ± 25.4 a
pH	6.7 a	6.2 ± 0.07 a	4.7 ± 0.42 a
Conductivity µmhos/cm	4.9 a	5.3 ± 1.2 a	6.0 ± 1.47 a
<u>Unfiltered Heavy Metals, mg/l</u>			
Cd	0.110 ± 0.020 a	0.133 ± 0.109 a	<0.030
Cu	1.05 ± 0.232 a	0.970 ± 0.339 a	1.47 ± 2.1 a
Mn	0.295 ± 0.049 a	0.190 ± 0.085 a	<0.100
Ni	0.150 ± 0.072 a	0.183 ± 0.039 a	<0.520
Zn	1.10 ± 0.234 a	3.62 ± 1.40 a	2.98 ± 2.4 a
Cr	0.650 ± 0.101 a	0.255 ± 0.113 a	0.293 ± 0.15 a
<u>Filtered Heavy Metals, mg/l</u>			
Cd	0.08 ± 0.017 a	0.112 ± 0.111 a	0.016 ± 0.02 b
Cu	0.109 ± 0.016 a	0.622 ± 0.168 a	1.47 ± 2.02 a
Mn	0.158 ± 0.019 a	0.158 ± 0.080 a	0.740 ± 0.77 a
Ni	0.090 ± 0.012 a	0.128 ± 0.045 a	0.188 ± 0.19 a
Zn	0.43 ± 0.082 a	1.06 ± 0.463 a	3.07 ± 2.84 a
Cr	0.01 ± 0.002 a	0.008 ± 0.001 a	0.016 ± 0.01 a

* Concentrations from different tests followed by the same letter are not statistically different at P = 0.05 .

Site Management for Controlling Surface Runoff Water Quality

Vegetative establishment

91. Vegetation was successfully established only on plots amended with lime plus horse manure and lime plus sand plus gravel plus horse manure. Vegetation on these plots was sparse and occurred primarily in cracks where the soil amendments were considered. All other plots were completely void of vegetation.

Surface runoff water quality tests

92. Results of surface runoff water quality tests conducted on the site management test plots are presented in Table 6. Heavy metal concentrations in surface runoff from plots amended with lime, sand, and gravel were not

Table 5
Effects of Drying and Oxidation on Surface Runoff Water Quality
from the BRH Field Site

Field Parameter	Field		USEPA Maximum Criteria
	Unfiltered	Filtered	
	<u>Wet Dredged Material</u>		
SS, mg/l	9,247	N*	N
pH	7.5	N	N
EC, dS/m	6.7	N	N
Cd, mg/l	0.218	0.0004	0.0015 - 0.0024
Cu, mg/l	24.5	0.008**	0.012 - 0.043
Ni, mg/l	1.63	0.012	1.3 - 3.1
Zn, mg/l	16.1	0.081**	0.180 - 0.570
Mn, mg/l	2.61	0.102	N
Cr, mg/l	15.7	0.002	2.2 - 9.9
	<u>Dry, Oxidized Dredged Material</u>		
SS, mg/l	151	N	N
pH	4.7	N	N
EC, dS/m	6.0	N	N
Cd, mg/l	<0.030	0.016**†	0.0015 - 0.0024
Cu, mg/l	1.90	1.47**†	0.012 - 0.043
Ni, mg/l	<0.520	0.188†	1.3 - 3.1
Zn, mg/l	2.98	3.07**†	0.180 - 0.570
Mn, mg/l	<0.100	0.740†	N
Cr, mg/l	0.293	0.016	2.2 - 9.9

* N = no value available.

** Filtered concentrations were statistically equal to or greater than the USEPA Maximum Criteria for the Protection of Aquatic Life (P = 0.05).

† Filtered concentrations were not statistically different from unfiltered concentration (P = 0.05).

statistically lower than concentrations in surface runoff from the control plots. The addition of horse manure to lime, sand, and gravel did, however, significantly reduce both unfiltered and filtered concentrations of cadmium, copper, nickel, manganese, and zinc. Addition of horse manure also reduced the percent soluble cadmium, copper, nickel, and zinc in surface runoff (Table 7).

Table 6
Effect of Soil Amendments on Filtered and Unfiltered
Heavy Metal Concentrations, mg/l

<u>Parameter</u>	<u>Control</u>	<u>Lime, Sand, Gravel</u>	<u>Lime, Sand, Gravel Manure</u>
		<u>Unfiltered</u>	
Cd	0.55 ± 0.44 a*	0.40 ± 0.28 ab	0.06 ± 0.02 b
Cu	57 ± 38 a	38 ± 20 ab	10 ± 4.4 b
Cr	12 ± 7.3 a	7.9 ± 1.5 ab	3.9 ± 1.4 b
Ni	3.5 ± 2.2 a	2.7 ± 1.4 ab	0.95 ± 0.25 b
Mn	4.1 ± 2.3 a	3.4 ± 1.6 a	0.85 ± 0.29 b
Zn	40 ± 31 a	27 ± 17 ab	3.7 ± 1.2 b
		<u>Filtered</u>	
Cd	0.56 ± 0.44 a**	0.36 ± 0.25 ab**	0.02 ± 0.01 b**
Cu	47 ± 34 a**	31 ± 21 a**	2.0 ± 2.7 b**
Cr	0.49 ± 0.29 a	0.23 ± 0.20 ab	0.004 ± 0.004 b
Ni	3.1 ± 2.3 a	2.2 ± 1.4 a	0.21 ± 0.14 b
Mn	3.1 ± 2.2 a	2.6 ± 1.6 a	0.33 ± 0.21 b
Zn	40 ± 29 a**	27 ± 18 ab**	2.3 ± 1.7 b**

* Treatments with the same letters were not significantly different (P = 0.05).

** Value exceeded the USEPA Maximum Criteria for the Protection of Aquatic Life (P = 0.0).

Ground-Water Monitoring

93. Time constraints allowed only one sample collection from four of the six wells prior to dredged material placement into the site. The analysis of unfiltered ground-water samples for PCBs would represent a "worst case" for contaminant release. Contaminants bound to particles or those that are part of the mineral matter in the water are naturally filtered in an aquifer (Chen et al. 1978; Bower 1978). The unfiltered ground-water samples collected at 6 months showed PCB levels slightly above initial background. Concentrations of PCBs (Table 8) were slightly above background in ground water from monitoring wells adjacent to the site at 6 months after dredged material placement; after 12 months, only one well showed a slight increase above background; and after 14 months, no PCBs were detectable in filtered and unfiltered ground-water samples.

Table 7
Percent Soluble Heavy Metals* in Surface Runoff from
Field Plots Treated with Different Soil Amendments

<u>Parameter</u>	<u>Control</u>	<u>Lime, Sand, Gravel</u>	<u>Lime, Sand, Gravel, Manure</u>
Cd	104 a**	99 a	47 b
Cu	73 a	72 a	15 b
Cr	5 a	3 a	1 a
Ni	77 a	73 b	22 b
Mn	69 a	66 a	35 b
Zn	100 a	92 a	57 b

* Filtered or soluble concentrations divided by the unfiltered or total concentration.

** Treatments with the same letters were not significantly different (P = 0.05).

Table 8
PCB Ground-Water Analysis at the FVP Field Site

<u>Well*</u>	<u>Sampling Time/Type of Sample (Concentration = µg/l)</u>				
	<u>Predredging</u>	<u>6-month</u>	<u>12-month</u>	<u>14-month</u>	
	<u>Unfiltered</u>	<u>Unfiltered</u>	<u>Unfiltered</u>	<u>Unfiltered</u>	<u>Filtered</u>
MW1	<0.20	0.30	0.40	<0.20	<0.20
MW2	<0.20	0.30	<0.20	<0.20	<0.20
MW3	**	1.30	<0.20	<0.20	<0.20
MW4	<0.20	0.40	<0.20	<0.20	<0.20
MW5	<0.20	<0.20	3.40	<0.20	<0.20
MW6	**	8.7	16.0	<0.20	<0.20

* Wells MW1-MW4, located outside the disposal site, and MW5, located within the disposal site, were designed to monitor the ground water. Well MW6 was used to monitor interstitial water of the BRH dredged material in the disposal site.

** Dredging schedule conflicts prevented sample collection prior to filling.

94. Heavy metals in ground-water samples are presented in Table 9. Concentrations of arsenic, cadmium, chromium, iron, lead, and manganese in predredging ground-water samples were above the Connecticut ground-water standards. This indicated that the ground-water was already contaminated. Arsenic concentrations in ground-water samples from the wells around the site remained above the standard for only one well (MW4); arsenic in other wells

Table 9
Metal Analysis of Ground Water at the FVP Upland Site, Concentration, µg/l

Sample Well*	AS	Cd	Cr	Cu	Fe	Pb	Mn	Ni	Zn	Hg
Pre/Unfil										
MW1	0.056	0.0031	0.087	0.160	14.7	0.185	0.834	0.649	0.680	0.0006
MW2	0.056	0.0069	0.008	0.023	1.23	0.039	0.620	0.358	0.063	<0.0004
MW4	0.049	0.0029	0.056	0.095	9.32	0.126	0.697	0.946	0.187	<0.0004
MW5	0.680	0.0276	0.496	0.882	52.7	0.906	7.02	6.49	1.32	<0.0004
6-Non/Unf										
MW1	0.009	0.0049	0.004	0.012	2.25	0.006	0.449	0.067	<0.030	0.0007
MW2	0.031	0.0232	0.004	0.059	0.119	0.003	0.364	0.397	0.060	0.0005
MW3	<0.005	0.0012	0.003	0.036	9.45	0.042	1.11	0.031	<0.030	<0.0004
MW4	0.076	0.0028	0.004	0.024	0.383	<0.001	0.099	0.225	<0.030	0.0005
MW5	0.160	0.0068	0.012	0.036	15.3	0.033	0.502	0.202	0.063	0.0006
MW6	0.008	0.0777	0.517	1.27	7.48	0.102	1.02	0.579	5.92	0.0008
12-Non/Unf										
MW1	0.006	0.0120	0.006	0.045	4.81	0.028	0.206	0.128	0.092	<0.0004
MW2	0.033	0.0571	0.003	0.087	0.043	<0.001	0.466	0.381	0.043	<0.0004
MW3	0.004	0.0082	<0.001	0.011	6.91	0.011	1.01	0.040	<0.030	<0.0004
MW4	0.070	0.0012	<0.001	0.026	0.233	0.003	0.133	0.337	<0.030	<0.0004
MW5	0.120	0.0012	0.089	0.081	11.5	0.050	0.554	0.464	0.104	<0.0004
MW6	0.006	1.32	0.292	25.3	4.25	0.051	2.96	2.08	24.3	<0.0004
14-Non/Unf										
MW1	<0.005	0.0028	0.002	0.036	3.10	<0.001	0.316	0.103	0.068	<0.0004
MW2	0.032	0.0088	0.005	0.063	0.071	<0.001	0.426	0.329	0.042	<0.0004
MW3	<0.005	0.0007	0.004	0.003	6.79	<0.001	0.881	0.030	<0.030	<0.0004
MW4	0.069	0.0008	0.003	0.008	0.346	<0.001	0.095	0.185	<0.030	<0.0004
MW5	0.650	0.0057	0.307	0.677	76.5	<0.001	0.693	2.89	0.715	0.0006
MW6	0.038	1.32	2.07	79.4	28.3	<0.001	4.16	3.54	28.2	0.0030
14-Mon/Fil										
MW1	<0.005	0.0027	0.009	0.010	<0.030	<0.001	0.278	0.038	<0.030	<0.0004
MW2	0.032	0.0144	0.005	0.065	<0.030	<0.001	0.416	0.322	<0.030	<0.0004
MW3	<0.005	0.0005	0.005	0.022	<0.030	<0.001	1.36	0.029	<0.030	<0.0004
MW4	0.074	0.0011	0.003	0.010	<0.030	<0.001	0.086	0.170	<0.030	<0.0004
MW5	0.085	0.0022	0.003	0.011	<0.030	<0.001	0.693	0.480	<0.030	<0.0004
MW6	<0.005	1.26	0.029	47.5	0.053	<0.001	3.54	2.84	25.8	<0.0004
**	0.05	0.010	0.05	1.0	0.3	0.05	0.05	--	5.0	0.002

* Wells MW1-MW4, located outside the disposal site, and MW5, located within the disposal site, were designed to monitor the ground water. Well MW6 was used to monitor interstitial water of the dredged material in the disposal site.

** Connecticut ground-water standard (American Petroleum Institute 1983).

decreased over time. Wells MW2 at 6, 12, and 14 months and MW1 at 12 months contained cadmium above the standard; all other wells were below Connecticut standards and lower than the predredging concentration. Cadmium was still present in excess of the State standards in filtered ground-water samples from one of the wells (MW2) after 14 months. Iron and manganese exceeded Connecticut ground-water standards; however, iron and manganese concentrations decreased in all the wells outside the site when compared with predredging concentrations. Copper, nickel, zinc, and mercury did not exceed State standards in any of the ground-water samples taken from around the site and in most cases decreased when compared with predredging concentrations. Manganese decreased in concentration in all the wells compared with predredging levels, which indicated that manganese was present in the soils before disposal operations. After 14 months, arsenic was only slightly above State standards; it was also above State standards before disposal operations. Cadmium appears to be the only heavy metal migrating from the site; therefore, monitoring of ground water for cadmium should continue.

Plant Response

Laboratory

95. Chemical analysis of the BRH sediment (Table 10) indicated that the sediment would eventually become extremely acidic (dry pH < wet pH) and highly saline upon air-drying (high EC); thus, under upland disposal conditions, the dredged material would become a harsh environment for plants to survive. Previous investigations involving similarly acidic saline sediments (Folsom 1982a and 1982b) have shown that growth of the index plants on such sediments is possible only if the sediments are rinsed with freshwater to remove salt and are limed to increased pH.

96. Total metal content (Table 11) of the BRH sediment was relatively high; the copper content was extremely high (Folsom, Lee, and Bates 1981). The data show that air-drying resulted in increased DTPA extractable metals. Washing the sediment before air-drying slightly reduced DTPA metal extractability of cadmium, copper, and nickel; DTPA extractable chromium and lead were increased. Based on results of the DTPA extractions, one could predict that potential plant uptake of metals in the field would be significantly greater from the air-dried upland disposed sediment than from the flooded

Table 10
Selected Physical and Chemical Parameters
of BRH Sediment

<u>Parameter</u>	<u>Concentration</u>
Organic matter	19.5%
Salinity	28.0 ppt
Electrical conductivity	35.7 dS/m
CaCO ₃ equivalent	0.9%
pH wet	7.6
pH reconstituted* air-dried	6.6
Lime requirement**	4.8 mg/g
Oil and grease	17.5 mg/g
Total sulfur	1.3%

* Reconstituted air-dried pH is pH of a 1:2 sediment to solution suspension using air-dried sediment.

** Air-dried upland sediment limed to pH 7.0.

Table 11
Total Acid Digestible and DTPA Extractable Concentrations (µg/g)
of Selected Metals in BRH Sediment

<u>Heavy Metal</u>	<u>Total Acid Digestible Original Sediment</u>	<u>DTPA Extractable</u>		
		<u>Original Sediment</u>		<u>Washed Sediment</u>
		<u>Flooded</u>	<u>Upland</u>	<u>Upland</u>
Zn	1,370	3.33b*	962a	961a
Cd	23.3	0.047c	28.7a	26.6b
Cu	2,860	0.473c	387a	225b
Ni	203	7.59c	66.9a	53.0b
Cr	1,403	0.313c	0.828b	2.16a
Pb	399	0.175c	16.3b	28.6a

* Mean of four replicates. Means followed by the same letter in a row are not significantly different at P = 0.05 using Waller-Duncan K-Ratio T-Test.

wetland disposed sediment. Also, the chemical data from the laboratory portion of the plant bioassay indicated that *S. alterniflora* and *S. virginicus* would not grow especially well under upland conditions and would accumulate excessive levels of heavy metals.

97. As expected from the chemical analyses of composited BRH sediment (Tables 10 and 11), both *S. alterniflora* and *S. virginicus* did not grow well in the greenhouse in the composited unwashed air-dried (upland) BRH sediment: only one plant of one replicate of *S. alterniflora* survived. The elevated heavy metal content of the surviving plants could be explained by the reduced plant growth (*S. alterniflora*, Table 12; *S. virginicus*, Table 13 (Folsom and Lee 1985)). Plants grown in washed sediment under an upland condition grew better than those grown in the unwashed sediment under an upland condition. Analysis of variance conducted on the greenhouse-grown *S. alterniflora* data revealed that the heavy metal content of *S. alterniflora* grown in the oxidized washed sediment was not different from that of plants grown in sediment under original flooded conditions. The heavy metal content of the one surviving plant in the unwashed upland treatment was extremely high (Table 12). Heavy metal content of *S. virginicus* grown in the oxidized-washed sediment was statistically different from that of plants grown in sediment under original flooded conditions at $P = 0.10$, but not at $P = 0.05$ (Table 13). *Sporobolus virginicus* grown in washed-upland sediment overpredicted all the metals except cadmium. Apparently, in the case of *S. alterniflora*, removing excess salt allowed better plant growth compared with plant growth in the unwashed upland sediment. The increased growth of plants on the washed upland sediment diluted the metals within the greater plant biomass, which resulted in decreased heavy metal concentrations. In situations where plant growth does not increase (e.g., *S. virginicus*), then heavy metal concentrations appear to increase and plant uptake of heavy metals may appear to be greater from air-dried upland sediments than from the flooded sediment, resulting in overprediction of heavy metal uptake. This same effect has also been found for *S. alterniflora* grown in Wales* and was observed by Folsom and Lee (1981a and 1981b) when freshwater plants were grown in freshwater sediments under both flooded and upland disposal environments. Apparently, once estuarine

* Personal Communication, Dr. Brian E. Davies and Ms. Nicola J. Houghton, University College of Wales, Penglais, Aberystwyth, Great Britain.

Table 12
Plant Content ($\mu\text{g/g}$) of Selected Metals in Leaf Tissue of
S. alterniflora Grown in Sediment from BRH

Heavy Metal	Greenhouse			Field, 1986	
	Original Sediment		Washed Sediment	Wetland	Upland
	Flooded	Upland*	Upland	Flooded	Upland
Zn	12.1 \pm 1.26**	219	26.2 \pm 16.7	19.2 \pm 7.05	No survival
Cd	0.041 \pm 0.007	0.91	0.10 \pm 0.08	<0.0025	
Cu	4.02 \pm 1.39	18.7	2.81 \pm 2.35	7.48 \pm 5.55	
Ni	0.954 \pm 0.388	†	1.51 \pm 1.68	0.743 \pm 0.67	
Cr	0.274 \pm 0.322	0.93	10.3 \pm 12.3	6.17 \pm 5.49	
Pb	0.237 \pm 0.44	1.53	<0.013	0.945 \pm 0.89	

* Only one replicate supported plant growth.
 ** \pm 1 standard deviation.
 † Not analyzed.

Table 13
Plant Content ($\mu\text{g/g}$) of Selected Metals in Leaf Tissue of
S. virginicus Grown in Sediment from BRH

Heavy Metal	Greenhouse			Field	
	Original Sediment		Washed Sediment	Wetland	Upland
	Flooded	Upland	Upland	Flooded	Upland
Zn	26.2c*	40.1b	86.3	No survival	66.0ab
Cd	0.857b	0.684b	1.34ab		2.22a
Cu	10.7b	24.3ab	34.5a		19.8b
Ni	6.82bc	22.8a	13.4b		5.38c
Cr	<0.025c	8.64ac	0.506b		7.64a
Pb	<0.013b	<0.013b	<0.013b		1.56a

* Means within a row followed by the same letter are not significantly different at $P = 0.10$ using the Least Significant Difference method.

sediment is washed free of excess salt and the pH is adjusted by the addition of lime, good plant growth can occur. The air-drying process that results in increased availability of metals in combination with enhanced plant growth due to salt removal and pH adjustment may mask increased plant uptake of heavy metals (i.e. a dilution effect). Removing excess salt from sediment by washing is similar to natural salt leaching from rainfall so that washing may be used as part of the estuarine plant bioassay to estimate contaminant uptake by plants growing on estuarine dredged material in upland disposal sites.

Field

98. Plant death in the upland site was very convincingly predicted from the chemical data and results of the greenhouse portion of the plant bioassay. An in situ plant bioassay was attempted at the FVP upland site, but no plants survived. Since prediction of plant death was so strong, *S. alterniflora* was not planted in the upland site. However, *S. virginicus* should have survived, based on the greenhouse prediction using the washed upland sediment data, if the acidic condition was corrected by addition of lime. Analysis of field-grown *S. virginicus* revealed that uptake of some of the metals was over-predicted. Cadmium and zinc contents in the field-grown plants were relatively close to values observed in the greenhouse. Nickel and copper were predicted to be elevated; field results showed, however, that they were not elevated. Lead contents were predicted to be low in greenhouse-grown plants; field-grown plants, however, had higher lead contents.

99. Adjustments are needed in the estuarine plant bioassay procedure to improve prediction of plant uptake of the heavy metals (especially lead) from estuarine dredged material in upland disposal.

Animal Response

Laboratory

100. Total worm weights recovered from each of the three test substrates decreased during the test period (Table 14). Although the worms were not counted, the 56-percent decrease in animal weight recorded in the mixture of BRH sediment and WES reference soil was largely due to the reduction in the number of worms. The reduced weights from the other two substrates (16 and 12 percent of the beginning live weight) appeared to be due to starvation rather than mortality.

Table 14
Weight Changes of Earthworms After 7-Day Exposure to
Various Substrates (BRH)

Substrate	Weight of Worms, g (wet wt)		Weight Loss in 7 Days, %
	Initial	Final*	
10% BRH sediment + 90% WES reference soil	40	17.4 ± 5.4	56
BRH reference sediment	40	33.7 ± 1.8	16
WES reference soil	40	35.0 ± 1.5	12

* Mean of three replicates ±1 standard deviation.

101. Results of the analysis of the earthworm tissue for cadmium, chromium, copper, nickel, lead, zinc, and mercury in relation to substrate levels indicated that bioaccumulation was not demonstrated (Table 15). Some accumulation of chromium, copper, nickel, and lead was expected due to the high concentrations of these metals in the substrate material; however, the concentrations of these elements with the exception of copper in the worm tissues were quite low. In contrast, cadmium was found to be consistently higher in the worm tissue than in the substrate material, even in background tissue levels. This may have been due to a higher-than-desirable background level of cadmium (4.55 µg/g) in the worms prior to the test period or to the potential of the earthworm to accumulate cadmium from low levels in the media (Hartenstein, Neuhauser, and Collier 1980). The values reported in the literature for various earthworm species indicated that cadmium levels in earthworm tissues are generally greater than those of the substrate (Simmers et al. 1986). All PCBs and PAHs were below detection limits in the earthworm tissues.

Field

102. Field tests conducted at the site indicated that field verification of the laboratory earthworm bioassay was not possible. The salinity of the dredged material was too high for survival of soft-bodied soil invertebrates. The field tests attempted to exploit the alterations made through the site restoration/vegetation procedures. However, no earthworms survived in

Table 15
Contaminant Concentrations in Earthworms After a 7-Day
Laboratory Exposure to Various Substrates

Contam- inant	Type of Substrate - Contaminant Concentration,* $\mu\text{g/g}$ dry wt						
	10% BRH Sediment + 90% WES		BRH Reference Sediment		WES Reference Soil		Background Worm Tissue
	S**	T	S	T	S	T	T
Cd	2.9	5.83 \pm 0.80	2.9	4.26 \pm 0.55	0.2	3.80 \pm 0.34	4.55 \pm 0.21
Cr	191	4.73 \pm 1.55	314	6.96 \pm 0.28	8.07	2.53 \pm 0.06	1.90 \pm 0.20
Cu	330	34.1 \pm 1.4	438	33.8 \pm 1.3	9.86	12.0 \pm 0.60	11.25 \pm 0.52
Ni	29.6	6.03 \pm 2.97	45	3.07 \pm 0.84	15.0	3.33 \pm 1.18	0.49 \pm 0.46
Pb	63.5	7.6 \pm 0.13	135	5.13 \pm 0.63	10.3	4.7 \pm 0.10	5.23 \pm 0.40
Zn	176	110.5 \pm 2.3	329	112.3 \pm 1.5	29.5	102.6 \pm 0.6	118.5 \pm 2.9
Hg	0.19	<0.05	0.5	<0.05	<0.05	<0.05	<0.05

* Concentration is mean of three replications \pm 1 standard deviation.

** S = substrate.

T = tissue.

any of the treatments. None of the procedures tested allowed earthworm survival, and all earthworms were dead after 1 hr.

PART V: DISCUSSION

Effluent Water Quality

Comparison of the laboratory and field modified elutriate test procedure

103. Effluent water quality predicted in the laboratory was directly compared with the field data for purposes of verifying the accuracy of the overall predictive technique. Dissolved concentrations of contaminants and the contaminant fractions of the SS are compared with the corresponding field values as shown in Figure 23. Similar plots comparing the predicted total concentrations of contaminants, based on both the modified elutriate and column settling test data, with the total concentrations obtained in the field are shown in Figure 24. Ratios of predicted mean values to field mean values are summarized in Table 16.

104. Accuracy of the modified elutriate test procedure as a predictor varied among the parameters analyzed. In most cases, predicted results were within the range of the field results; however, the data were highly variable. Predicted results were on the conservative side for most of the contaminants that were a function of SS (i.e., the predicted fractions are higher than the observed field fractions). This can be explained by the fact that, under quiescent laboratory testing conditions, only the fine colloidal particles will remain in suspension. In the field, turbulence and resuspension by wind currents can cause coarser particles containing relatively low levels of adsorbed contaminants to be discharged in the effluent. Since finer particles have a greater affinity for contaminants, it is reasonable to expect the modified elutriate test procedure to predict a higher contaminant fraction of the TSS.

105. The predicted concentrations of most dissolved contaminants were lower than the observed field concentrations. This may be explained by the potential scavenging of dissolved contaminants by the settling of particles, which occurred more effectively under the quiescent laboratory condition.

106. Ratios of predicted to field values are summarized in Table 16. Predictions made by the modified elutriate test procedure were within a factor of 1.5 times the field value for 20 of 24 parameters measured. Accuracy within a factor of 1.5 compares favorably with similar predictive procedures

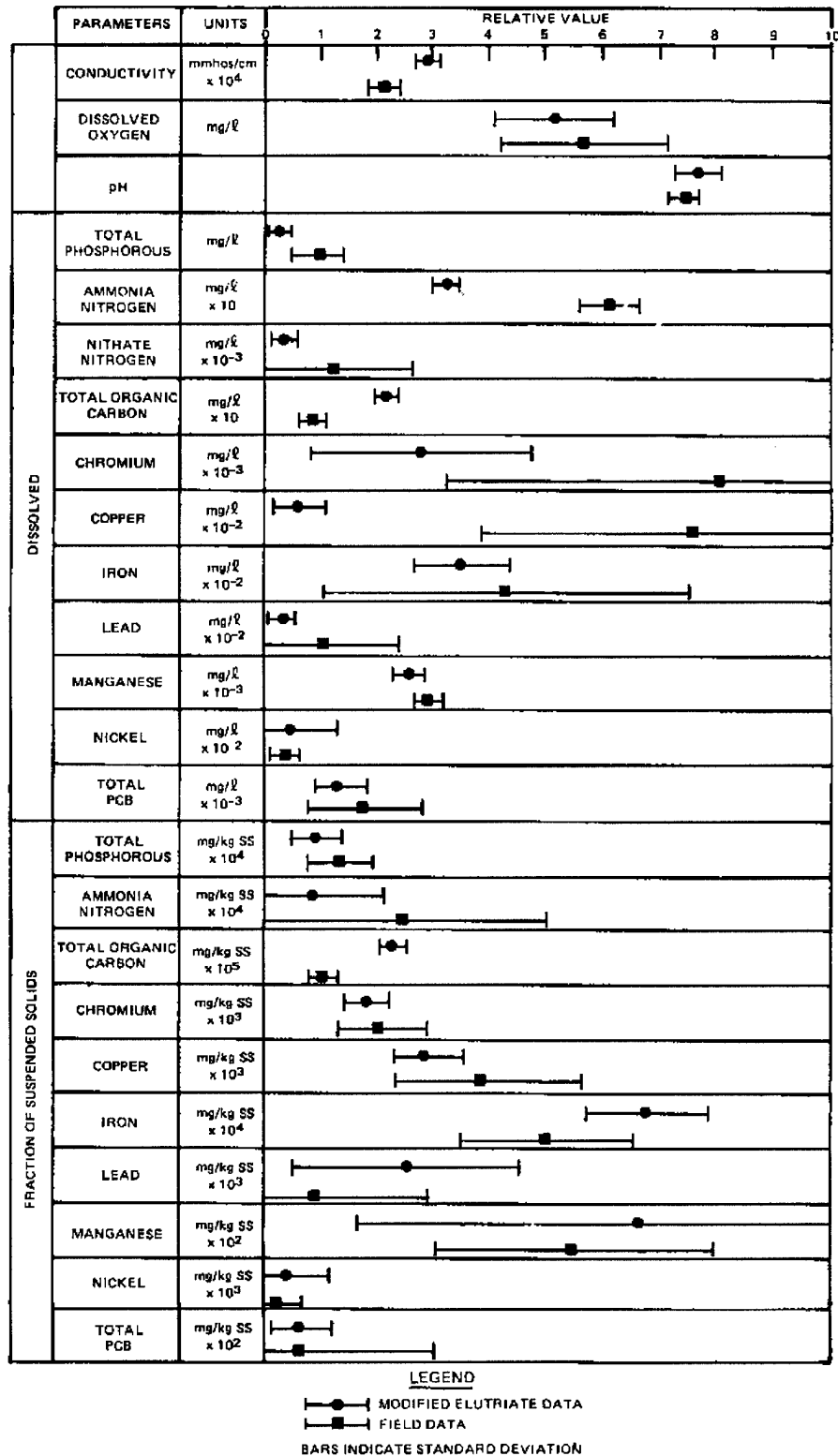

Figure 23. Plots of means and standard deviations of modified elutriate laboratory test and measured field data, BRH

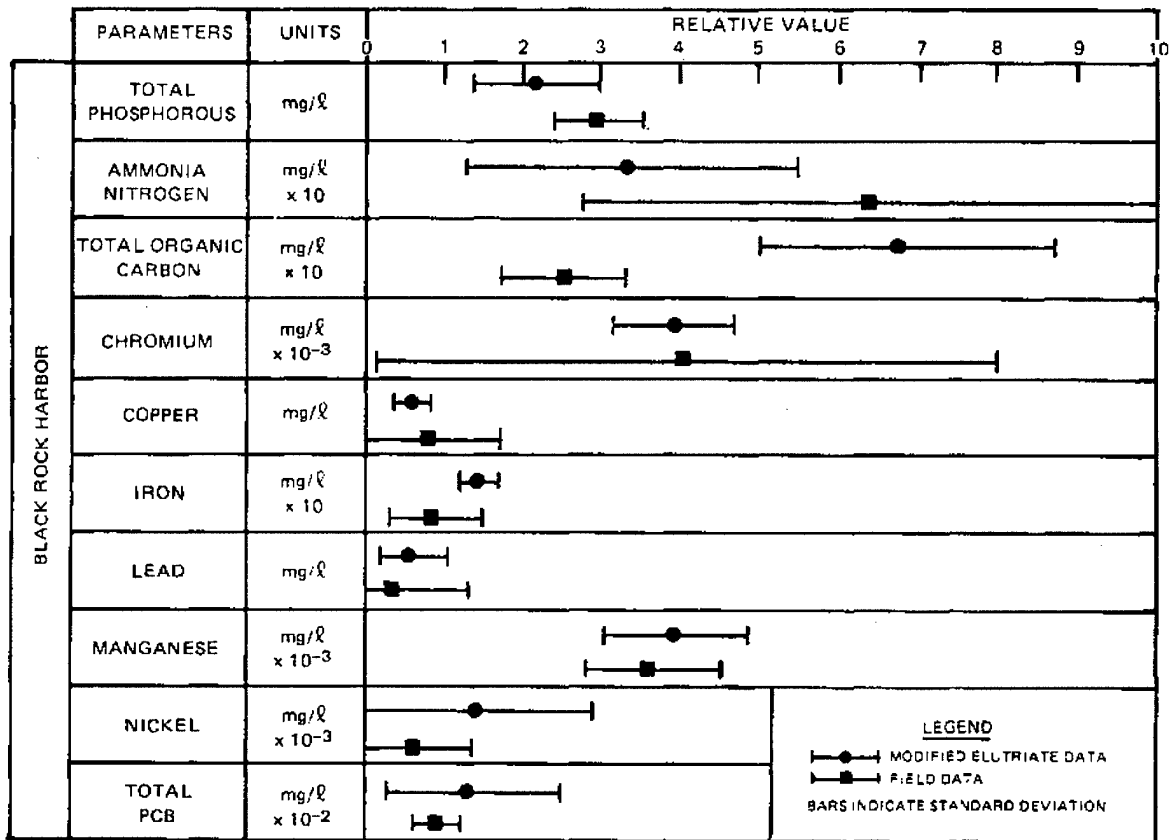

Figure 24. Plots of means and standard deviations of laboratory predicted and measured field data for total concentrations of contaminants

for evaluation of the suitability of dredged material for open-water disposal, such as standard elutriate tests.

Comparison of predicted total concentrations with field data

107. As with the modified elutriate test procedure, predicted values of total contaminant concentrations were generally on the conservative side (i.e., higher predictions than that obtained in the field). This behavior would be expected since both the predicted TSS concentration, as estimated by column settling data, and the associated contaminant fractions, as estimated by the modified elutriate data, are conservative.

Table 16
Ratios of Predicted Effluent Concentrations
to Field Mean Effluent Concentrations

<u>Parameter</u>	<u>Dissolved Concentration</u>	<u>Fraction of TSS</u>	<u>Total Parameter SS</u>
Conductivity	--	--	1.3
Dissolved oxygen	1.4	--	--
pH	0.9	--	--
Total phosphorus	1.0	--	--
Ammonia nitrogen	0.2	0.7	0.7
Nitrate nitrogen	0.5	0.4	0.5
Total organic carbon	0.3	--	--
Chromium	2.3	2.2	2.8
Copper	0.3	0.9	1.0
Iron	0.1	0.7	0.7
Lead	0.8	1.3	1.7
Manganese	0.3	2.6	1.7
Nickel	0.9	1.2	1.1
Total PCB	1.5	2.0	2.1
	0.8	0.9	1.3
Avg ratios for all parameters	0.8	1.3	1.4

108. The column settling analysis predicted 216 mg/l as the effluent SS concentration, which is 1.3 times the mean field effluent concentration of 173 mg/l. This degree of conservatism was reflected in the subsequent prediction of total contaminant concentrations. These predictions were within a factor of 1.5 times the field values for 7 of 11 parameters. Predictions for the remaining parameters ranged from 1.7 to 2.8 times the field value.

Surface Runoff Water Quality

109. Results of the surface runoff water quality test procedure conducted on wet, anaerobic sediment showed that contaminants were poorly soluble and tightly bound to the particulates. Total or unfiltered concentrations of heavy metals in surface runoff from the FVP upland site were excessive but easily controlled. Allowing the SS to settle out of the surface runoff would remove over 99 percent of the contaminants.

110. While dissolved or filtered contaminants in surface runoff from wet, anaerobic dredged material may be extremely low in comparison with the total or unfiltered concentrations, the USEPA Maximum Allowable Criteria for the Protection of Aquatic Life may still be exceeded. Filtered concentrations of copper and zinc in surface runoff from the wet, anaerobic BRH dredged material were equal to the criteria. Based on these results, no restriction or control measures were indicated for dissolved contaminants in surface runoff while the BRH dredged material remained wet, anaerobic.

111. When contaminated dredged material is allowed to dry and oxidize, significant physicochemical changes that occur in the material increase the solubility of some contaminants. Filtered or dissolved concentrations of cadmium, copper, nickel, zinc, and manganese in surface runoff from dry, oxidized BRH dredged material were not statistically different from unfiltered or total concentrations. Allowing the SS to settle out of the surface runoff would therefore only decrease chromium.

112. Comparison of filtered concentrations with the USEPA Maximum Criteria for the Protection of Aquatic Life showed that the criteria were significantly exceeded by cadmium, copper, and zinc by one to two orders of magnitude. Some form of control measures or restrictions were indicated for dissolved contaminants in surface runoff from an FVP upland site. Examples of possible restrictions or control measures include:

- a. Considering a mixing zone in the discharge receiving area.
- b. Capping the contaminated material with clean uncontaminated material.
- c. Containing all surface runoff on the disposal site.
- d. Treating the surface runoff before discharge.
- e. Treating the dredged material with soil amendments to reduce the solubility of the contaminants.

Site Management for Controlling Surface Runoff Water Quality

Vegetation establishment

113. Vegetation was extremely difficult to establish on the upland BRH disposal site primarily because of high salt concentrations (electrical conductivity 30 to 60 ds/m) and low soil pH (pH < 5.0). While many very salt-tolerant species of plants have been identified in the literature, none were able to tolerate the extremes found at the field site. The addition of large quantities of soil amendments including horse manure, lime, sand, and gravel did allow some species to exist on the site. However, growth was sparse and mainly in the cracks. As the upland disposal site ages, salt will be leached from the material, and plant survival and growth will improve on the site.

114. Low soil pH can severely inhibit plant survival and growth on a disposal site. However, this problem can be easily remedied through the use of lime as prescribed by standard lime requirement tests. Lime requirement tests were conducted on the BRH dredged material for these field tests and the plant bioassay tests. These tests indicated the need for high lime-application rates.

Surface runoff water quality tests

115. The site management test plots contained dredged material that had undergone considerable weathering beyond that of the dredged material tested in earlier laboratory lysimeters and field verification test plots. The field plots were established 2 years after the dredged material had been placed in the site, and the surface runoff tests were conducted 3 years after disposal. During these 3 years, the site was managed to prevent contaminants from being discharged from the site by controlling the discharge weir. This control measure had significant long-term effects on the dredged material by trapping salts, eroded particulates, surface runoff water, and soluble and insoluble heavy metals on the disposal site. For this reason, filtered and unfiltered heavy metal concentrations in surface runoff were greater from the site management test plots than from the earlier laboratory surface runoff predictions and field verification tests.

116. Soil amendments were effective in reducing filtered and unfiltered heavy metal concentrations in surface runoff from the FVP upland site. Filtered or dissolved concentrations of cadmium, copper, nickel, zinc, and

manganese were reduced by an order of magnitude with the addition of horse manure to the lime, sand, and gravel.

117. The combination of the large quantities of soil amendments on the surface of the plots along with the established vegetation reduced the erodability of the dredged material and thus the total or unfiltered concentrations of heavy metals in runoff. In addition, the horse manure did significantly reduce the percentage of soluble metals cadmium, copper, nickel, zinc, and manganese. The overall effect was to significantly reduce the unfiltered and filtered concentrations of heavy metals in surface runoff from plots amended with lime, sand, gravel, and manure.

118. Although filtered concentrations of heavy metals in surface runoff from the lime, sand, gravel, and manure plots were reduced by an order of magnitude, the filtered concentrations of cadmium, copper, and zinc still exceeded the USEPA Maximum Criteria for the Protection of Aquatic Life. Additional restrictions or control measures were needed for upland disposal of BRH dredged material. If a mixing zone in the receiving area outside the disposal site were considered, then the addition of the soil amendments might reduce the size of the required area by an order of magnitude. For other less contaminated dredged material, these soil amendments could reduce the filtered heavy metal concentrations to within the selected criteria.

Ground-Water Monitoring

119. Results of the ground-water monitoring at the FVP upland site indicated that an initial plume of PCBs may have migrated into the ground water after placement of the BRH sediment into the site. However, due to the lack of background data, it may not be accurate to state the PCBs migrated into the ground water, especially since concentrations were near or below detectable limits. Analysis of ground water for heavy metals indicated that cadmium might have been the only metal to have migrated from the site into the ground water. Iron was associated with particulate matter and would be retained within the upper reaches of the aquifer. Although manganese appeared to have migrated from the site, manganese concentration in all the wells decreased compared with predredging levels. Arsenic concentrations were above Connecticut State standards both in unfiltered and filtered ground-water samples, but arsenic was also above State standards before disposal operations

and is probably not migrating from the FVP site. Cadmium appears to be the only heavy metal that showed increased concentrations in ground water after disposal operations. Monitoring of the ground water in wells from around the upland site would be warranted in light of these findings to verify that migration of cadmium had occurred. Since the dredged material has drained and dried out, it may turn out that migration of cadmium has ceased and that its migration was only transient. Also, because of a lack of background data and the effect of possible seasonal fluctuations, cadmium too may not be migrating from the FVP upland disposal site. In any case, further monitoring of cadmium in the ground water at the FVP upland disposal site should be conducted.

Plant Response

120. Contaminated dredged material placed in confined upland disposal sites eventually becomes vegetated with a variety of natural plant species (Lee, Folsom, and Bates 1983). The availability or release of contaminants contained in dredged material has been shown to increase as the material undergoes oxidation (Gambrell et al. 1977). The plant bioassay procedure was developed to investigate potential mobility of contaminants into the environment through uptake of contaminants by plants grown on contaminated dredged material. Research results showed that plant uptake of heavy metals increased as the degree of oxidation increased in freshwater sediments (Folsom, Lee, and Bates 1981; Folsom and Lee 1981a and 1981b; Folsom and Lee 1985). The plant bioassay procedure developed for freshwater sediments was applied to an estuarine sediment in the laboratory/greenhouse, and heavy metal uptake by the plants was determined. The same plant species were grown in contaminated dredged material placed under field conditions. These plants were analyzed for heavy metals. The plant contents of field-grown plants were compared with those grown in the greenhouse.

121. The greenhouse study predicted that the plants would not grow in unamended dredged material in the field. Field results verified this prediction as no plants survived in the unamended material. The greenhouse data predicted that if the dredged material were amended to correct for low pH, a salinity-tolerant plant species might survive. Plants did survive in the amended dredged material in both the greenhouse and the field. Results from the greenhouse predicted that plants grown in the washed, amended material

would take up excessive amounts of some of the heavy metals and not take up others. Analysis of field-grown *S. virginicus* revealed that uptake of all the metals was not accurately predicted. Cadmium and zinc contents in the field-grown plants were relatively close to values observed in the greenhouse. Greenhouse test results indicated that plant contents of cadmium and zinc would be elevated; field results also showed that they were elevated. Nickel, chromium, and copper were predicted to be elevated; field results showed, however, that they were not elevated. Lead content was predicted to be low by greenhouse-grown plants; field-grown plants, however, had higher lead contents. Adjustments need to be made to the estuarine plant bioassay procedure to improve prediction of plant uptake of the heavy metals (especially lead, from estuarine dredged material to be placed in an upland disposal environment).

Animal Response

122. The earthworm bioassay procedure has proven to be a highly sensitive and reliable test procedure in the prediction of potential toxicity of freshwater sediments both at the time of dredging and after disposal (Simmers, Richards, and Pikul 1986; Simmers et al. 1986). Some difficulties are inherent in the utilization of this test procedure to predict the potential consequences of upland disposal of estuarine dredged material. Observations at several confined disposal facilities containing dredged material from estuarine projects have confirmed the relationship of salinity to earthworm toxicity or the inability of earthworms to be early colonizers of such sites. This appears to be an osmoregulatory problem as hard-boiled invertebrates with more conservative water regulation strategies can and do colonize such sites.

Field Verification of Laboratory Methods Placed Under Field Conditions

123. The laboratory predictions of the earthworm bioassay test procedure were confirmed in the field. It was predicted that earthworms would not survive in the undiluted BRH dredged material under oxidized, upland conditions; and through 1986, none did. This appears to be the result of osmoregulatory limitations of the earthworm and not contaminants.

PART VI: CONCLUSIONS

Effluent Water Quality

124. The modified elutriate test adequately predicted the dissolved concentration of contaminants and the contaminant fractions of the TSS in the effluent for the FVP site. Comparison of replicate test results with field data indicated that the modified elutriate test was generally a conservative predictor. The modified elutriate results were within 1.5 times the field values for DO, pH, and conductivity; dissolved ammonia nitrogen, nitrate nitrogen, total phosphorus, chromium, copper, iron, lead, manganese, nickel, and PCB; and particle-associated ammonia nitrogen, total phosphorus, chromium, copper, iron, manganese, and PCB. Values for particle-associated total organic carbon, lead, and nickel, and dissolved total organic carbon were within 2.0 to 2.6 times the field value. The column settling analysis and corresponding prediction of effluent SS concentration compared favorably with field data and yielded a conservative estimate of the effluent SS for the FVP site. The predicted value was 1.3 times the field value.

Surface Runoff Water Quality

125. Laboratory lysimeter and field surface runoff water quality test procedures conducted on the composited BRH sediment and the subsequent FVP upland dredged material showed that significant physicochemical changes did occur in the dredged material when it was allowed to dry and oxidize. These changes significantly modified the surface runoff water quality from the dredged material. Significant decreases in SS and unfiltered heavy metal concentrations were measured in surface runoff as the material dried and oxidized, whereas significant increases in filtered concentrations of copper, cadmium, nickel, manganese, and zinc were measured. Filtered concentrations of chromium, however, did not significantly change as the material dried and oxidized. These results were shown on the laboratory lysimeter tests conducted on both the composited BRH sediment and the subsequent upland dredged material, and then field verified.

Ground Water

126. Results of the ground-water monitoring at the site indicated that an initial plume of PCBs may have migrated into the ground water after placement of the BRH sediment into the site. However, after 14 months, PCB levels had decreased to below detectable limits, which indicated that any migration from the site had ceased. Analysis of ground water for heavy metals revealed that only cadmium may have migrated from the site into the ground water. Arsenic, manganese, and cadmium concentrations were above Connecticut State standards both in unfiltered and filtered ground-water samples, but arsenic and manganese concentrations were above standards prior to disposal operations.

Plant Bioassay

127. The estuarine plant bioassay procedure was used in the laboratory to evaluate heavy metal uptake by plants from composited BRH sediment. The laboratory study predicted that *S. alterniflora* would not grow in unamended dredged material in the field. This was verified as no *S. alterniflora* plants survived in the unamended material. The laboratory test predicted that amendment of the dredged material to raise the pH and washing to remove excess salinity might result in survival of a salinity-tolerant plant species such as *S. virginicus*. *Sporobolus virginicus* did survive in the amended material in both the laboratory and the field.

128. Laboratory test results indicated that plant contents of cadmium and zinc would be elevated; field results showed that they were elevated. Nickel, chromium, and copper were predicted to be elevated; field results showed, however, that they were not elevated. Lead content was predicted to be low in laboratory-grown plants; field-grown plants, however, had higher lead contents.

Animal Bioassay

129. The upland animal bioassay procedures applied to the composited BRH sediment predicted that the earthworms would not survive in undiluted BRH

dredged material under oxidized, upland conditions; and through 1986, none did.

PART VII: RECOMMENDATIONS

Effluent Water Quality

130. Additional comparisons of predictions with field data should be made under a wider variety of operating conditions. These additional comparisons should also include organic contaminants with varying tendencies for adsorption to particles. The testing procedures may then be modified if appropriate to improve accuracy and/or precision. This is currently an ongoing effort under the CE Long-Term Effects of Dredging Operations research program.

Surface Runoff Water Quality

131. The only significant difference between the laboratory lysimeter tests and the field tests was that surface runoff pH was lower in the field.

132. After the initial dewatering of the site, the outlet weir was controlled to prevent surface runoff from being discharged from the site. All surface runoff from the Laboratory lysimeters, however, was completely removed from the lysimeter. During the first 5 to 6 months of drying and oxidation, moisture contained in the dredged material was migrating to the surface by capillary along with acid-forming materials such as sulfides. As the moisture evaporated, the acid-forming materials were deposited at the surface and then redissolved during storm events, either simulated or natural.

133. Because the runoff was discharged from the laboratory lysimeter and not from the field site, acidity was removed from the laboratory lysimeter but trapped on the field site, resulting in a lower pH in the field. Heavy metals during the first 5 to 6 months were poorly soluble and would not have been leached from the material until later. The low pH that developed in the upland dredged material at the FVP field site was predicted using techniques developed to predict lime requirements on acid mine spoil material. It is recommended that the site be managed to prevent contaminants from being discharged.

Ground Water

134. Only cadmium appeared to have migrated from the site after 14 months. However, because of a lack of predredging background data and possible effects of seasonal fluctuations in the ground water at the FVP upland site, ground-water monitoring should be conducted. Since the dredged material has drained and dried out, it is possible that migration of cadmium has ceased and that its migration into the ground water was only transient and may not represent a major problem.

Plant Bioassay

135. Results of the estuarine plant bioassay indicated that adjustments are needed in the procedure to improve prediction of plant uptake of metals. One such adjustment should deal with simulating the natural "aging" of the saline dredged material. Even though excess salinity was removed in the laboratory through washing, there may not have been sufficient time during the drying process to adequately simulate oxidation of organic matter and sulfides. It is recommended that future implementation of the estuarine plant bioassay procedure consider this long-term oxidation process to improve laboratory prediction of contaminant mobility into the environment through plant uptake.

Animal Bioassay

136. After two years of drying and aging, the dredged material in the FVP upland site was still toxic. The short-term prediction of potential toxicity has been made in the laboratory and verified in the field. Long-term potential contaminant uptake by animals at the site cannot be accurate until the toxic effect of salinity is reduced through modifications of the laboratory procedures of the animal bioassay. Not only must salinity be removed, but, as in the plant bioassay, the long-term effect of oxidation of organic and sulfide materials must be addressed so that future applications of the animal bioassay will be able to predict potential contaminant uptake.

REFERENCES

- American Petroleum Institute (API). 1983. "Guide to Ground-Water Standards of the United States," API Publication 4366.
- American Public Health Association. 1981. Standard Methods for the Examination of Water and Wastewater, 15th ed., American Water Works Association, Water Pollution Control Federation, Washington, DC.
- Bower, H. 1978. Ground-Water Hydrology, McGraw-Hill, Inc., New York.
- Chen, K. Y., et al. 1978. "Confined Disposal Area Effluent and Leachate Control (Laboratory and Field Investigations)," Technical Report DS-78-7, US Army Engineer Waterways Experiment Station, Vicksburg, Miss.
- Folsom, B. L., Jr. 1982a. "Heavy Metal Content of *Spartina alterniflora* from Pawtuxet Cove, Rhode Island," Memorandum for Record, US Army Engineer Waterways Experiment Station, Vicksburg, Miss.
- _____. 1982b. "Heavy Metal Content of *Spartina alterniflora* from the Texas City Prototype Marsh on the Texas City Dike," Memorandum for Record, US Army Engineer Waterways Experiment Station, Vicksburg, Miss.
- Folsom, B. L., Jr., and Lee, C. R. 1981a. "Development of a Plant Bioassay for Determining Toxic Metal Uptake from Dredged and/or Fill Material," Proceedings--International Conference, Heavy Metals in the Environment, Amsterdam, The Netherlands, pp 417-420.
- _____. 1981b. "Zinc and Cadmium Uptake by the Freshwater Marsh Plant *Cyperus esculentus* Grown in Contaminated Sediments Under Reduced (Flooded) and Oxidized (Upland) Disposal Conditions," Journal of Plant Nutrition, Vol 3, pp 233-244.
- _____. 1982. "On the Adequacy of Mixing Large Volumes of Sediment," Agronomy Abstracts, 1982 Annual Meetings, Anaheim, Calif.
- _____. 1985. "Plant Bioassay of Dredged Material," Environmental Effects of Dredging Technical Note EEDP-02-1, US Army Engineer Waterways Experiment Station, Vicksburg, Miss.
- Folsom, B. L., Jr., Lee, C. R., and Bates, D. J. 1981. "Influence of Disposal Environment on Availability and Plant Uptake of Heavy Metals in Dredged Material," Technical Report EL-81-12, US Army Engineer Waterways Experiment Station, Vicksburg, Miss.
- Gambrell, R. P., et al. 1977. "Transformations of Heavy Metals and Plant Nutrients in Dredged Sediments as Affected by Oxidation Reduction Potential and pH, Vol II: Materials and Methods/Results and Discussion," Contract Report D-77-4, US Army Engineer Waterways Experiment Station, Vicksburg, Miss.
- Hartenstein, R., Neuhauser, E. F., and Collier, J. 1980. "Accumulation of Heavy Metals in the Earthworm *Eisenia foetida*," Journal of Environmental Quality, Vol 9, pp 23-26.
- Laws, J. O., and Parsons, D. A. 1943. "The Relation of Raindrop Size to Intensity," Transactions of the American Geophysical Union, Vol 24, p 452.

- Lee, C. R., Folsom, B. L., Jr., and Bates, D. J. 1983. "Prediction of Plant Uptake of Toxic Metals Using a Modified DTPA Extraction," The Science of the Total Environment, Vol 28, pp 191-202.
- Lee, C. R., et al. 1985. "Restoration of Problem Soil Materials at Corps of Engineer Construction Sites," Instruction Report EL-85-2, US Army Engineer Waterways Experiment Station, Vicksburg, Miss.
- Montgomery, R. L. 1979. "Development of a Methodology for Designing Fine-Grained Dredged Material Sedimentation Bases," Ph.D. Dissertation submitted to Vanderbilt University, Nashville, Tenn.
- Palermo, M. R. 1985. "Interim Guidance for Predicting the Quality of Effluent from Dredged Material Disposal Areas," Environmental Effects of Dredging Technical Notes EEDP-04-1 through 04-4, US Army Engineer Waterways Experiment Station, Vicksburg, Miss. Also published as Miscellaneous Paper D-86-1.
- _____. 1986a. "Development of a Modified Elutriate Test for Predicting the Quality of Effluent from Confined Dredged Material Disposal Areas," Technical Report D-86-4, US Army Engineer Waterways Experiment Station, Vicksburg, Miss.
- _____. 1986b. "Interim Guidance for Predicting the Quality of Effluent from Confined Dredged Material Disposal Areas," Miscellaneous Paper D-86-1, US Army Engineer Waterways Experiment Station, Vicksburg, Miss.
- Palermo, M. R., Montgomery, R. L., and Poindexter, M. 1978. "Guidelines for Designing, Operating, and Managing Dredged Material Containment Areas," Technical Report DS-78-10, US Army Engineer Waterways Experiment Station, Vicksburg, Miss.
- Rhett, R. G., Simmers, J. W., and Lee, C. R. 1986. "Upland Animal Bioassays of Dredged Material," Environmental Effects of Dredging Technical Note, EEDP-02-02, US Army Engineer Waterways Experiment Station, Vicksburg, Miss.
- Simmers, J. W., Rhett, R. G., Kay, S. H., and Folsom, B. L., Jr. "FVP Wetland Synthesis Report," Technical Report in preparation, US Army Engineer Waterways Experiment Station, Vicksburg, Miss.
- Simmers, J. W., Rhett, R. G., Kay, S. H., and Marquenie, J. M. 1986. "Bioassay and Biomonitoring Assessments of Contaminant Mobility from Dredged Material," Science of the Total Environment, Vol 58, pp 173-182.
- Simmers, J. W., Richards, J. M., and Pikul, P. J. 1986. "Consequences of Dredged Material Aging in Confined Disposal Facilities, Environmental Contamination," Proceedings of the 2d International Conference, DEP Consultants, Edinburgh, Scotland.
- US Department of Energy. 1983. Acid Rain Information Book, 2d ed., DOE/EP-0018/1, Office of Environmental Analysis, Washington, DC.
- US Environmental Protection Agency. 1974a. "Analysis of Pesticide Residues in Human and Environmental Samples," Environmental Toxicology Division, Research Triangle Park, N. C.
- _____. 1974b. "Methods for Chemical Analysis of Water and Wastes," EPA 600/4-79-020, Office of Technology Transfer, Washington, DC.

US Environmental Protection Agency. 1982. "Handbook for Sampling and Sample Preservation of Water and Wastewater," EPA-600/4-82-029, Environmental Monitoring and Support Lab, Cincinnati, Ohio.

van Driel, W. C., Smilde, K. W., and van Luit, B. 1985. "Comparison of the Heavy-Metal Uptake of *Cyperus esculentus* and of Agronomic Plants Grown on Contaminated Dutch Sediments," Miscellaneous Paper D-83-1, prepared by Institute for Soil Fertility, Haren, The Netherlands, for the US Army Engineer Waterways Experiment Station, Vicksburg, Miss.

Westerdahl, H. E., and Skogerboe, J. G. 1982. "Realistic Rainfall and Watershed Response Simulations for Assessing Water Quality Impacts of Land Use Management," Modeling Components of Hydrologic Cycle, International Symposium on Rainfall-Runoff Modeling, Mississippi State University, Mississippi State, Miss., pp 87-104.

Wischmeier, W. H., Johnson, C. B., and Cross, B. V. 1971(Sep-Oct). "A Soil Erodability Nomograph for Farmland and Construction Sites," Journal of Soil and Water Conservation, pp 189-193.

Wischmeier, W. H., and Mannering, J. V. 1969. "Soil and Water Management and Conservation," Soil Science Society of America Proceedings, Vol 33, pp 131-137.

BIBLIOGRAPHY

- Gambrell, R. P., Khalid, R. A., and Patrick, W. H., Jr. 1978. "Disposal Alternatives for Contaminated Dredged Material as a Management Tool To Minimize Adverse Environmental Effects," Technical Report DS-78-8, US Army Engineer Waterways Experiment Station, Vicksburg, Miss.
- Hoepfel, R. E., Myers, T. E., and Engler, R. M. 1978. "Physical and Chemical Characterization of Dredged Material Influent and Effluents in Confined Land Disposal Areas," Technical Report D-78-24, US Army Engineer Waterways Experiment Station, Vicksburg, Miss.
- James R. Reed and Associates. 1983. "Analysis of Organic and Heavy Metal Constituents of Samples Taken from Norfolk Harbor Craney Island Disposal Area, Portsmouth, Virginia," Report submitted under Contract DACW 65-83-0602, Norfolk District, Norfolk, Va.
- Krizek, R. J., Gallagher, B. J., and Karadi, G. N. 1976. "Water Quality Effects of a Dredging Disposal Area," Journal of the Environmental Engineering Division, American Society of Civil Engineers, Vol EE2.
- Lee, C. R., and Skogerboe, J. G. 1984. "Restoration of Pyritic Soils and the Quantification of Erosion Control," Miscellaneous Paper EL-84-2, US Army Engineer Waterways Experiment Station, Vicksburg, Miss.
- Lu, C. S., Eichenberger, B., Knezevic, M., and Chen, K. Y. 1978. "Characterization of Confined Disposal Area Influent and Effluent Particulate and Petroleum Fractions," Technical Report D-78-16, US Army Engineer Waterways Experiment Station, Vicksburg, Miss.
- Meyer, L. D. 1958. "An Investigation of Methods for Simulating Rainfall on Standard Runoff Plots and a Study of the Drop Size, Velocity, and Kinetic Energy of Selected Spray Nozzles," Special Report No. 81, Purdue University, West Lafayette, Ind.
- Morin, J., Cluff, D. B., and Powers, W. R. 1970. "Realistic Rainfall Simulation for Field Investigation," presented at the 51st Meeting of American Geophysical Union, Washington, DC.
- Morin, J., Goldberg, D., and Seginer, I. 1967. "A Rainfall Simulator with a Rotating Disk," Transactions of the American Society of Agricultural Engineers, Vol 10, No. 1, pp 74-79.
- Office, Chief of Engineers (OCE). 1970. "Laboratory Soils Testing," Engineer Manual EM-1110-2-1906, Department of the Army, Washington, DC.
- Peddicord, R. K., et al. "Decisionmaking Framework for Management of Dredged Material: Application to Commencement Bay, Washington," Miscellaneous Paper in preparation, US Army Engineer Waterways Experiment Station, Vicksburg, Miss.
- Peters, R. E., Lee, C. R., and Bates, D. J. 1981. "Field Investigations of Overland Flow Treatment of Municipal Lagoon Effluent," Technical Report EL-81-9, US Army Engineer Waterways Experiment Station, Vicksburg, Miss.

Plumb, R. H. 1981. "Procedures for Handling and Chemical Analysis of Sediment and Water Samples," Technical Report EPA/CE-81-1, Technical Committee on Criteria for Dredged and Fill Material, US Army Engineer Waterways Experiment Station, Vicksburg, Miss.

Simmers, J. W., Folsom, B. L., Jr., Lee, C. R., and Bates, D. J. 1981. "Field Survey of Heavy Metal Uptake by Naturally Occurring Saltwater and Freshwater Marsh Plants," Technical Report EL-81-5, US Army Engineer Waterways Experiment Station, Vicksburg, Miss.

Steel, R. G. G., and Torrie, J. H. 1980. Principles and Procedures of Statistics, 2d ed., McGraw-Hill, New York.

US Army Engineer Waterways Experiment Station. 1953. "The Unified Soil Classification System," Technical Memorandum No. 3-357, Vicksburg, Miss.