



A Simple Digital Method for Compensation of Baseline Drift in Low-Frequency Small-Signal Waveform Measurements

by Thomas Kottke, David M. Perry,
and George M. Thomson

ARL-MR-446

June 1999

19990709 046

Approved for public release; distribution is unlimited.

The findings in this report are not to be construed as an official Department of the Army position unless so designated by other authorized documents.

Citation of manufacturer's or trade names does not constitute an official endorsement or approval of the use thereof.

Destroy this report when it is no longer needed. Do not return it to the originator.

Abstract

The need to measure relatively small signals mixed with drifting background levels and random noise is a common requirement in the laboratory environment. This report presents a simple device that continuously compensates for drifting baseline levels in systems where the background can be measured independently. The resulting level of automation allows the effects of random noise to be diminished through extensive signal averaging. For added flexibility, parameters such as the input voltage range and background sampling rate can be set by the user. All required hardware and software are provided and explained in detail.

Acknowledgments

The authors would like to thank the National Research Council (NRC) for providing funding for Dr. David M. Perry while this work was performed. The authors would also like to thank Dr. Laszlo J. Kecskes for technically reviewing and improving this report and Sandra Fletcher and Gina Zajdel, LB&B Associates Inc., for editorially reviewing, word processing, and polishing the final manuscript.

INTENTIONALLY LEFT BLANK.

Table of Contents

	<u>Page</u>
Acknowledgments	iii
List of Figures	vii
1. Introduction	1
2. Baseline Adjustment Device Embodiment	5
2.1 Overview	5
2.2 Electronic Details	8
3. Baseline Adjustment Device Software	11
4. A Performance Example	13
5. Conclusions	14
6. References	15
Appendix: PIC16C55 Controller Software Listing	17
Distribution List	25
Report Documentation Page	27

INTENTIONALLY LEFT BLANK.

List of Figures

<u>Figure</u>		<u>Page</u>
1.	Schematic of the Differential Detection Process.....	3
2.	Manual Method for Generating External Background Signals.....	4
3.	Schematic Overview of Baseline Adjustment Device Hardware.....	6
4.	Schematic Diagram of Baseline Adjustment Device Electronics	9
5.	Flowchart of PIC16C55 Controller Software.....	12
6.	Example of Baseline Adjustment Device Performance	14

INTENTIONALLY LEFT BLANK.

1. Introduction

In many electronic measurements, low-level broadband signals must be extracted, which are superimposed on a slowly varying background that drifts over a range many times that of the signal amplitude. The problem is compounded when the background contains higher frequency components (i.e., noise). In this report, a technique is presented that was devised at the U. S. Army Research Laboratory (ARL) to mitigate the effects of long-term baseline drift and thus allow the application of additional techniques for noise removal, such as signal averaging.

This technique is a by-product of ARL's investigations of methods for the remote detection and identification of airborne gases in the battlefield environment. One proposed method, called infrared fluorescence (IRF), uses a high-power laser to selectively excite one of an aerosol's constituent gaseous species. A telescope is then used to collect and analyze the characteristic infrared radiation emitted during that component's subsequent de-excitation processes. It is the detection of these fluorescent emissions that motivated the present work. They are not only intrinsically weak, but also superimposed on a noisy, drifting background. In the current discussion, drift and noise are distinguished by their respective nonrandom and random natures. In the IRF apparatus, drift arises from a combination of variations in the inherent thermal background radiation that permeates a room temperature environment; of changes in the properties of electronic components such as batteries, detectors, and amplifiers; and of stray electric or magnetic fields. These sources tend to be nonrepetitive and do not average out to zero over time. On the other hand, all detection systems and amplifiers are subject to a variety of random noises, such as Johnson noise, shot noise, and $1/f$ noise (Moore 1983). Clearly, the ability to extract the desired IR emission from the profusion of background and noise signals is both an essential requirement and a challenging task.

The ability to recover useful information from a detected signal (i.e., a mixture of a pure signal and random noise) is not a function of the absolute value of the pure signal but rather the signal-to-noise (SNR) ratio.

$$\text{SNR} = S / N \quad (1)$$

S is the amplitude of the pure signal and N is the amplitude of the random noise. The larger the SNR, the smaller the minimum detectable pure signal that can be recovered. Random noise has an equal probability of having a positive or negative sense and therefore averages out to zero over a long period of time. For a repetitive pure signal, the SNR can be increased by averaging the detected signal over multiple cycles. The improvement in the SNR with signal averaging can be expressed as:

$$\text{SNR}_{\text{ave}} = \sqrt{n} \cdot \text{SNR}_0 \quad (2)$$

SNR_{ave} is the signal-to-noise ratio of multiple averaged signals, SNR_0 is the signal-to-noise ratio of a single detector signal measurement, and n is the number of repetitive signals that are averaged. Another signal recovery technique, lock-in amplification, may be superior to signal averaging for improving SNR when the waveform is well-defined. However, the availability of computer-assisted data acquisition systems has, in recent years, made simple signal averaging an attractive alternative to other hardware intensive methods.

As already mentioned, background drift, unlike random noise, does not have an equal probability of having a positive or negative sense. Therefore, background drift does not have to average out to zero, even over a very long period of time. As a result, signal averaging will not eliminate a drifting background from a repetitive signal. Often during signal averaging, drift deviations may accumulate to the point where they swamp the averaged signal. A differential detection technique can be utilized to eliminate the background in systems where the background can be measured separately. Figure 1 illustrates a schematic of this process. The *Signal + Background* and *Background* signals are supplied to the two inputs of a differential amplifier. The output from a differential amplifier is proportional to the difference between the two inputs. Thus, the output from the differential amplifier will be the desired pure signal with the background element removed.

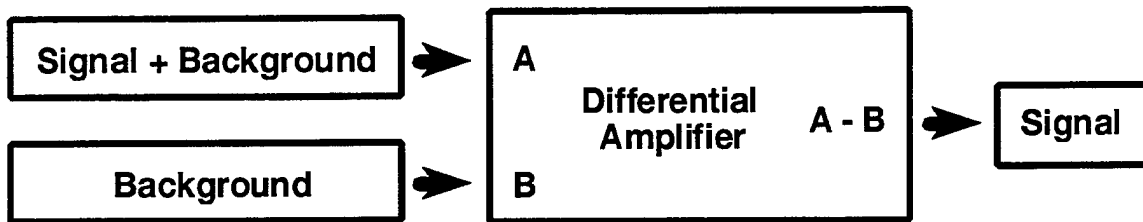

Figure 1. Schematic of the Differential Detection Process.

Clearly, the effort to recover a desired low-level signal immersed in a noisy drifting background, such as the present IR emission signal, can benefit from the application of both signal averaging and differential detection techniques—provided that the background signal can be independently measured. In the IRF scenario, the signal is the result of and temporally correlated with the pulsing of the high-power excitation laser. When the laser is off, the background signal can be measured; when the laser is on, the combined background and IR emission signal can be recorded.

With a known background signal, an external variable voltage source can be configured to mimic the measured background level. This external signal can be supplied to the background input of the differential amplifier to allow the pure IR emission signal to be separated from the background signal. An illustration of a manual method for performing this operation is presented in Figure 2. The operator, hereafter called Differential Person, observes the independently measured background signal level and adjusts the available potentiometer to a level that reproduces the current background level. This manually generated background reference signal is then subtracted from the combined IR emission and background signal via the differential amplifier.

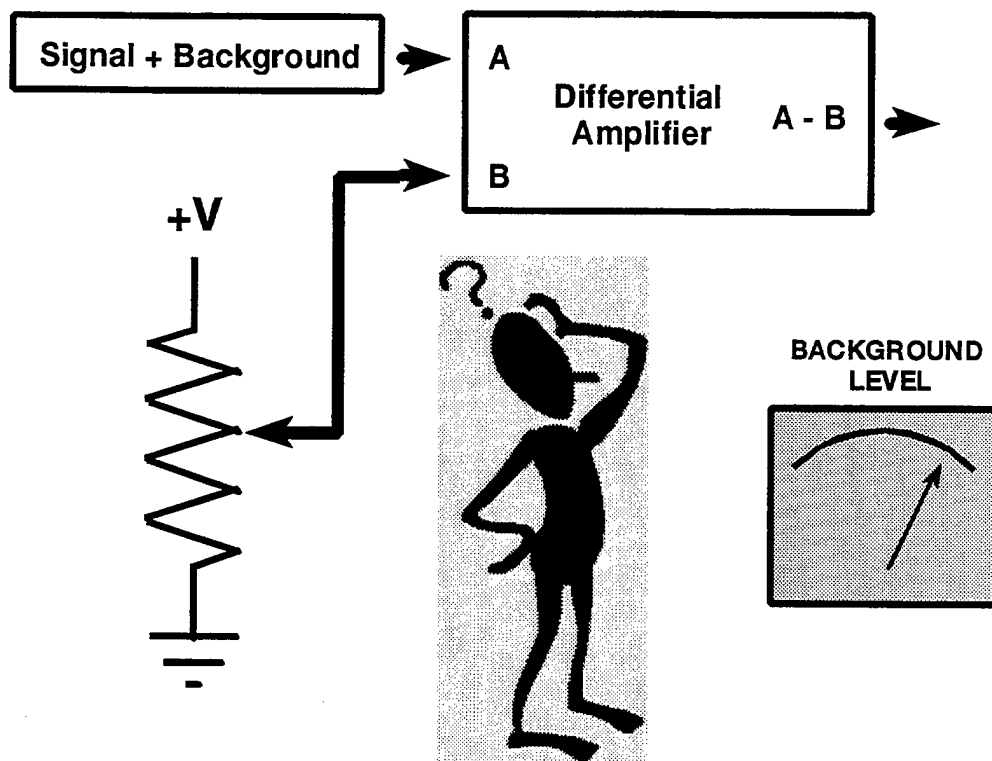

Figure 2. Manual Method for Generating External Background Signals.

Obviously, this manual method for generating the external background reference signal has a number of drawbacks. Background levels with even a moderate amount of drift may tax Differential Person's ability to manually recreate the background signal. Small signal measurements require sensitive measurement scales that span only a small fraction of the total signal's amplitudes. Under these conditions, even a minor deviation between the measured background level and the externally generated background reference signal may be sufficient to drive the differential amplifier's output signal beyond the available signal measurement range. Also, the desire to obtain a large number of repetitive measurements, so that the SNR can be reduced through averaging, may once again stress the operator's ability to consistently recreate the measured background signal level.

This report presents an automated baseline adjustment device (BAD) that can assist with the recovery of small signals that are mixed with a drifting background signal and random noise. The BAD monitors the output from the differential amplifier during periods when only the background signal is being detected. It then adjusts the potential applied to the background-only input of the differential amplifier to drive its output to a desirable baseline level. First, an overview will be presented of the hardware that performs this background subtraction process. The required electronic circuitry and its operation will then be considered in increasing detail. Included in these electronics is a controller that orchestrates the activities of the various components. The software that drives this controller will also be provided and discussed. While the apparatus described was designed for a specific application, its general operating principles, as well as many of its physical details, can be readily adapted to many signal recovery tasks.

2. Baseline Adjustment Device Embodiment

2.1 Overview. A schematic overview of the BAD hardware is illustrated in Figure 3. The ease with which this device can be implemented is due, in part, to the small number of external connections that need to be provided. A timing signal must be supplied to notify the BAD that the measurement system is currently recording only a background signal. It is during these intervals that adjustments to the baseline level are appropriate. For the IR emission measurement system this signal is synchronized with the pulsing of the high-power excitation laser. Specifically, baseline adjustments are performed while the laser is off and the detection system is recording only the ambient background level.

During the intervals that the laser is off, the BAD samples a feedback signal from the measurement system that indicates the amplitude of the present background level. In the case of the IR measurement system, this feedback is provided by the output of the differential amplifier. The actual background signal and the BAD-generated reproduction of the background level from the most recent sampling are fed into the differential amplifier's two inputs. Assuming that the background drift is not inordinately high, the differential amplifier's output can be expected to be

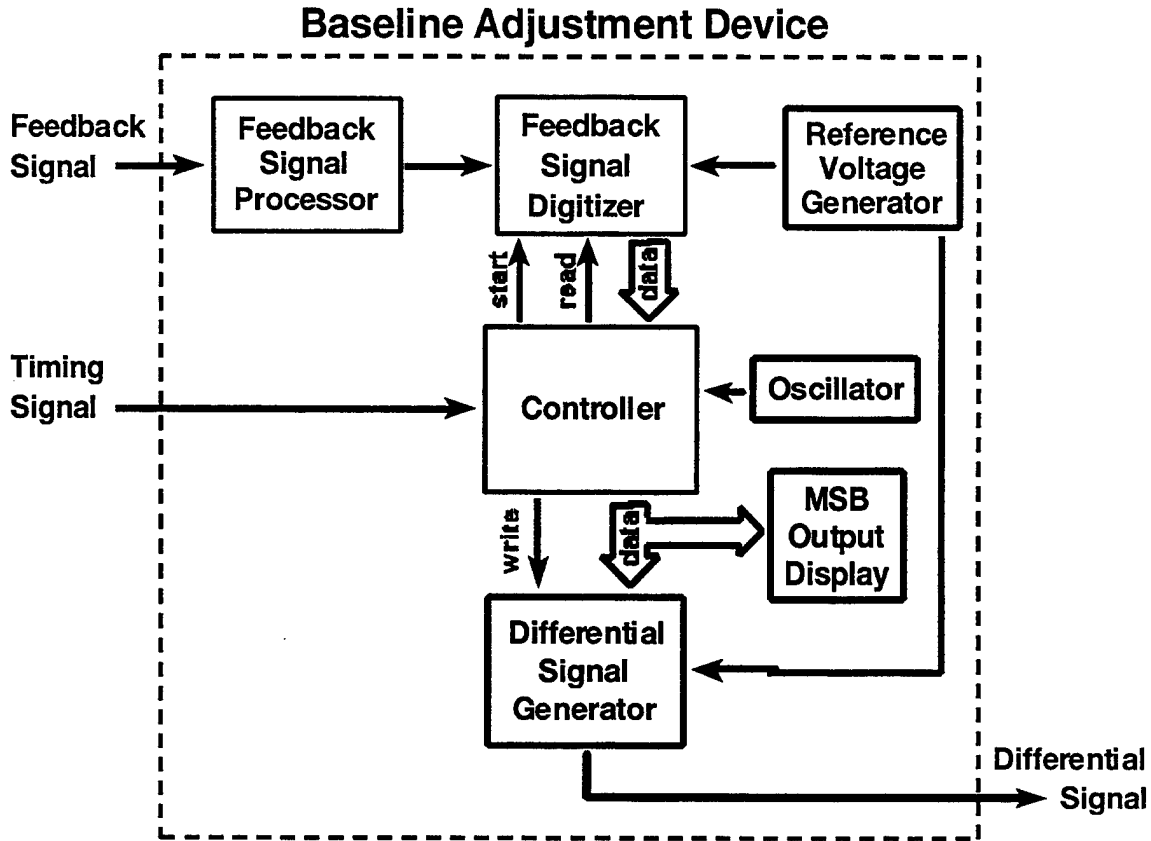

Figure 3. Schematic Overview of Baseline Adjustment Device Hardware.

near zero. This is in fact the very condition that allows small signals to be recorded on very sensitive scales. Depending on the sense in which the feedback signal deviates from the desired value, the BAD will either increase or decrease the magnitude of its output signal. This output signal provides the differential signal voltage that is looped back to the background-only input of the differential amplifier. Variations in this signal therefore alter the output from the differential amplifier. This closed-loop method has the effect of providing a signal to the background reference input of the differential amplifier that closely mimics the current background level. The BAD then resamples the feedback signal and adjusts the magnitude of the externally generated reference signal in an iterative fashion until the desired feedback signal level is obtained.

A brief overview of the electrical subsystems that make up the BAD is now provided. Input feedback signals are first scaled by a feedback signal processor. The function of this processor is to adjust the magnitude of the feedback signals to match the allowable input range of the subsequent feedback signal digitizer. This feedback signal processing is performed by an operational amplifier (op amp). The actual details of the characteristics of this op amp will depend on the constraints of the specific measurement problem. After being properly scaled, the feedback signal is digitized by an analog-to-digital convertor (ADC). This conversion from an analog to a digital signal is necessary to allow the inherently digital controller to read the current feedback signal value. The controller compares this current feedback signal level to the desired level and adjusts the value of a digital word that is output to the differential signal generator. The differential signal generator is a digital-to-analog convertor (DAC) that outputs an analog voltage that corresponds to the value of its digital input. Thus, the controller can adjust the magnitude of the analog differential signal by varying the value of the digital word that it writes to the differential signal generator.

The ADC and the DAC measure and produce analog voltages by comparing them to a reference voltage of known value. A reference voltage generator provides a constant, well-defined voltage that guarantees the accuracy of the convertor's performance. The controller's actions are paced by a crystal oscillator. Finally, the range of digital values that the controller can output to the differential signal generator is limited by the number of bits available for output. For this reason, it is desirable to operate the differential signal generator near the middle of its operating range. The most significant bits (MSB) of the digital word that the controller outputs to the differential signal generator are monitored by an MSB output display so that this condition can be maintained.

The problem described previously is also solvable by a number of analog circuits, which employ a looping process that is analogous to the method described previously. However, the utilization of digital elements of the type described in this report offer the advantages of enhanced precision, flexibility, and noise immunity. Moreover, the key components of this system are inexpensive, reliable, and widely available.

2.2 Electronic Details. The electronic circuitry and its operation are now presented in detail. A schematic diagram of this circuitry is illustrated in Figure 4. The two required inputs to the BAD are shown in the upper left-hand corner of this figure. For the IR emission measurements, the feedback signal is provided by the output from the differential amplifier, which is amplified and buffered through the vertical signal out port of a digital processing oscilloscope. This buffered output has a maximum range of ± 2 volts. As configured, the ADC0805 ADC that is used to digitize the feedback signal can convert analog signals over the range from 0 to 5 volts (National Semiconductor Company 1993). The feedback signal is matched to the measurement range of the ADC by the feedback signal processing circuitry consisting of the op amp IC1-A and the resistance dividing network of R8 and R9. The LM324 op amp is configured as a noninverting amplifier with a gain of 2.5. Thus, this op amp converts the ± 2 -volt feedback signal to a ± 5 -volt signal. This amplified signal is divided by the resistance network of R8 and R9 that is referenced to the +5-volt potential of V5REF. The function of this resistor network is to convert the bipolar ± 5 -volt output from the op amp to a 0–5-volt signal that matches the measurement range of the ADC.

The external timing signal is routed to the RA3 input line of the PIC16C55 controller. When the controller determines that the timing signal indicates that background adjustment is appropriate, the controller initiates an ADC by sending a negative pulse from its RA2 output to the WR bar input of the ADC0805. After waiting a period of time that exceeds the ADC's conversion time, the controller instructs the ADC to output the new conversion value on its DB# output lines by pulling its RD bar input low via output line RA1. The controller then reads in this value through its RB# inputs. The 8-bit size of this digital word and the 5-volt measurement range of the ADC offer conversion resolutions of approximately 19 mV.

The PIC16C55 controller compares the new ADC conversion value to a preprogrammed target value and determines the sense of the deviation. Depending on whether the conversion value is too high or too low, the controller will decrease or increase the value of the digital word

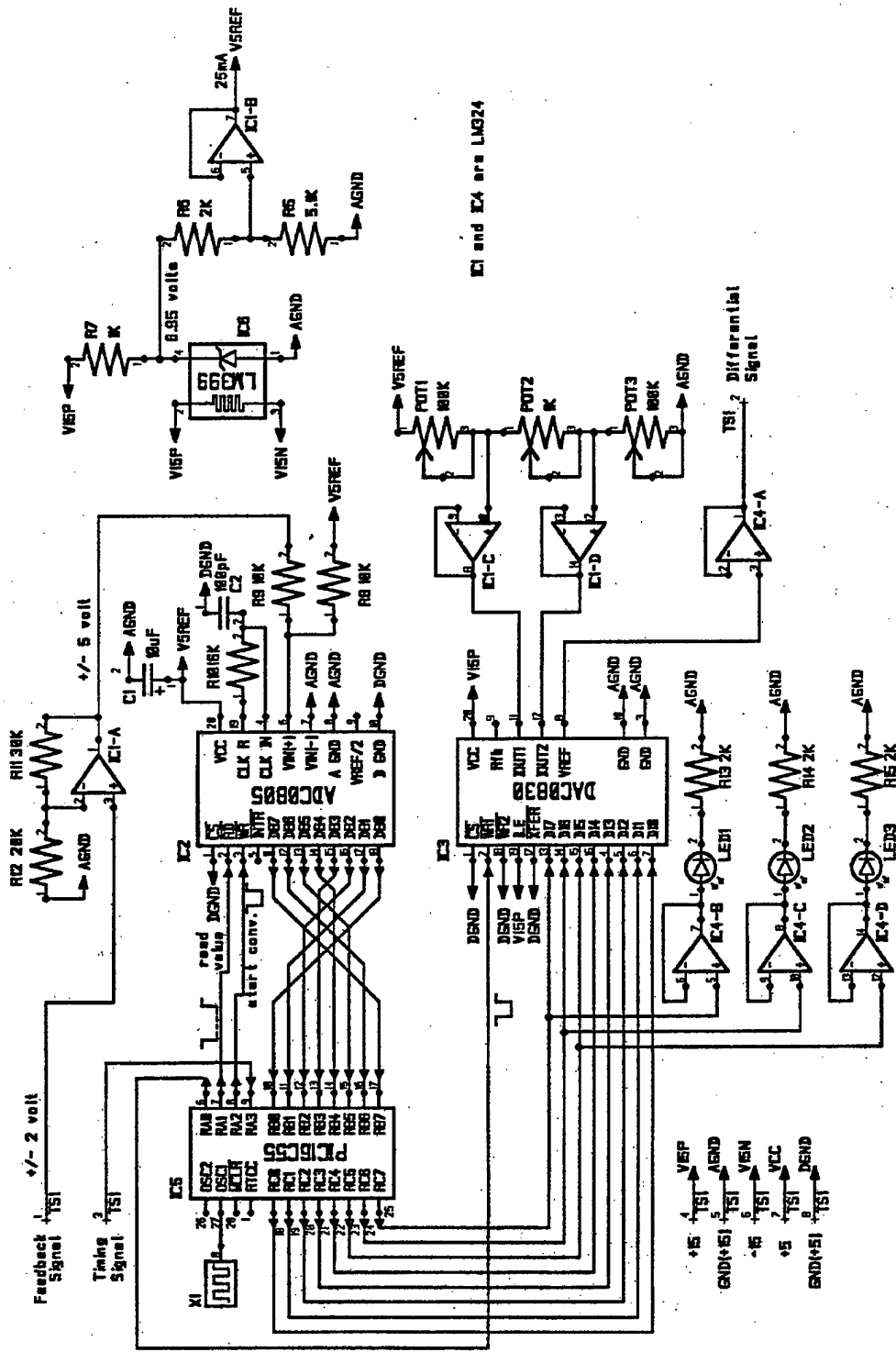

IC1 and IC4 are LM324

Figure 4. Schematic Diagram of Baseline Adjustment Device Electronics.

that it writes to the DI# inputs of the DAC0830 DAC via its RC# output lines. The controller forces the DAC to read in this new value by sending a low pulse from its RA0 output to the DAC's WR1 bar input.

The DAC0830 DAC uses an internal network of resistors to generate an output voltage that has a value between the potential supplied to input IOUT2 and the potential supplied at IOUT1. Specifically, the output voltage at VREF will be:

$$V_{VREF} = V_{IOUT2} + (D/256) \times (V_{IOUT1} - V_{IOUT2}). \quad (3)$$

V_{VREF} is the DAC output voltage at VREF, V_{IOUT2} is the potential supplied to input IOUT2, V_{IOUT1} is the potential supplied to input IOUT1, and D is the value of the digital word ($0 \leq D \leq 255$) supplied to the input's DI#. This ability to determine the range and span of DAC output values allows the required precision of the differential signal to be achieved. In combination, the potentiometers POT1 and POT3 determine the range of analog voltages that the DAC can produce. The magnitude of the setting of POT2, relative to the settings of POT1 and POT3, determines the span of the DAC's output range. By setting POT2 arbitrarily small, the output precision of the DAC can be made arbitrarily high over a very small range of voltages. Op amps IC1-C and IC1-D are used to buffer the input voltages from the potentiometer network to the DAC IOUT1 and IOUT2 inputs, while op amp IC4-A buffers the DAC's output voltage.

The BAD's ability to compensate for drifting background levels is maximized when the DAC is supplying a voltage that is near the middle of its range of output voltages. This condition is monitored by noting the value of the MSBs. The data lines of the DAC's three MSBs are buffered by op amps IC4-B, IC4-C, and IC4-D, and the corresponding data is displayed by LED1, LED2, and LED3. When operating, the potentiometer network is adjusted so that either LED1 is on while LED2 and LED3 are off or LED1 is off while LED2 and LED3 are on. Either of these conditions denote that the DAC is operating near the middle of its allowed range of output voltages.

A number of supply voltages must be provided to this electronic circuitry. For instrumentation that incorporates both analog and digital components, it is generally desirable to isolate the corresponding power supplies. This practice shields the analog components from the spikes that are commonly found on digital power lines. The digital power requirements are fulfilled by the 5-volt potential supplied across VCC and DGND. Analog power is provided via the +15-volt potential between V15P and AGND, and the -15-volt potential across V15N and AGND. These ± 15 -volt potentials are supplied directly to the op amps and the DAC. A +5-volt potential is also derived from the ± 15 -volt supply by an LM399 precision reference (National Semiconductor Company 1988). This monolithic device incorporates an active zener that is temperature stabilized by a heater to provide a stable, low-power reference voltage. An op amp scales this reference voltage to the required 5-volt potential and increases the available drive current to greater than 25 mA. This precision 5-volt potential between V5REF and AGND powers the potentiometer network and the analog portion of the ADC.

3. Baseline Adjustment Device Software

The internal processes of the BAD are orchestrated by a PIC16C55 controller. Specifically, the controller synchronizes the BAD's operation with the background-only phase of the measurement system, initiates the ADCs of the feedback signal, and adjusts the magnitude of the differential signal in an appropriate manner. The controller performs these operations by repeatedly executing the instructions contained in its erasable read-only memory (EPROM). A flowchart of this software is presented in Figure 5. For clarity, the macros that perform described functions are enclosed in square brackets in this figure. A listing of this code is presented in the Appendix.

When the PIC16C55 controller is powered up, a number of initializing procedures are executed. Upon power up, the input/output (I/O) pins default to a high-impedance input state. The macro SetTRIS defines the appropriate status of the I/O pins as either input or output. Even though the real-time clock/counter (RTCC) and watch-dog timer (WDT) capabilities of the PIC16C55 are not utilized in this application, the SetOPTION macro is used to define the associated option

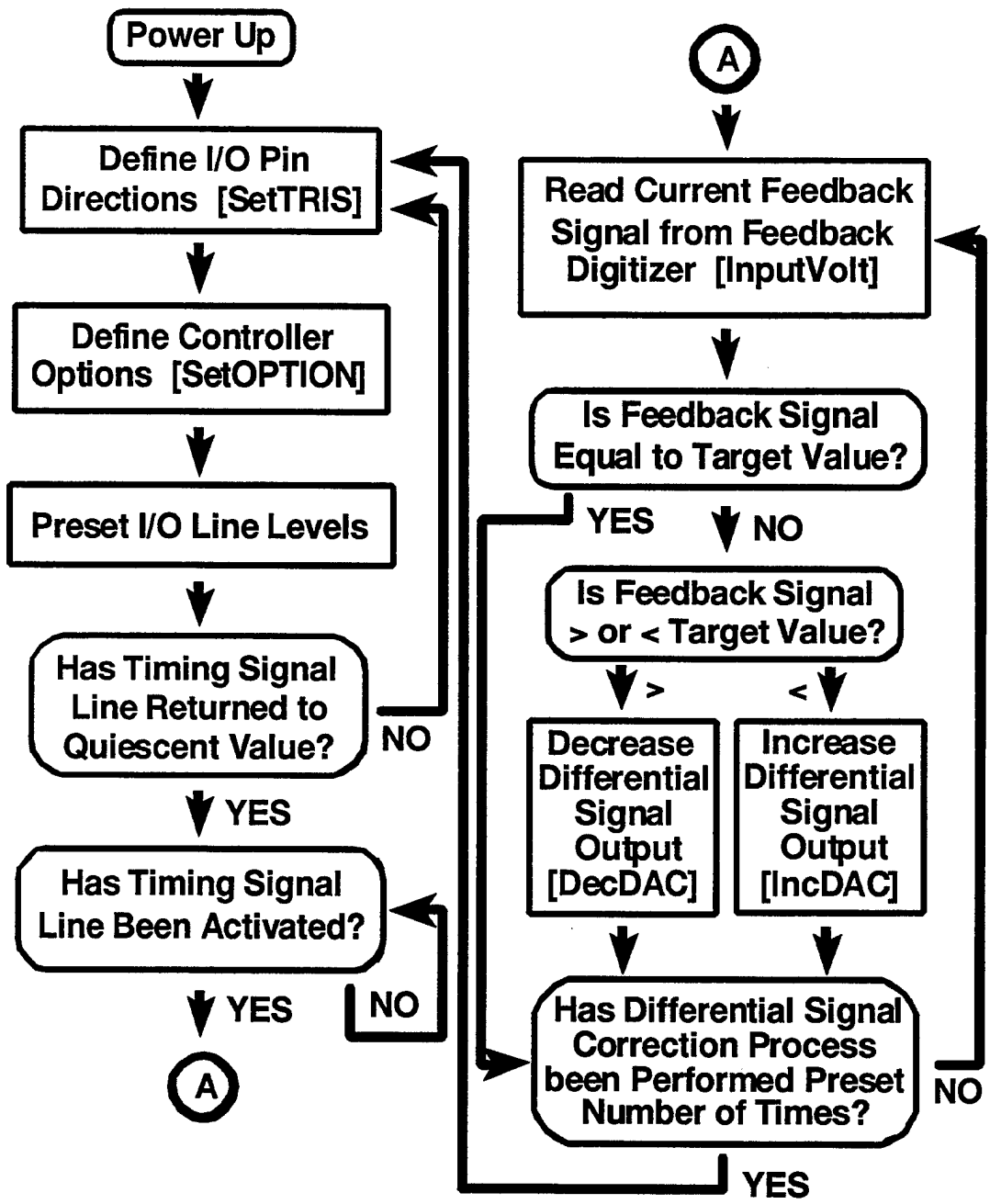

Figure 5. Flowchart of PIC16C55 Controller Software.

register to convenient, benign values. The I/O pins that were defined to be outputs are then set to an initial state that is compatible with the connected components. These initializing procedures are actually executed on a regular basis to avoid potential problems resulting from the corruption of register contents, which can occur in electrically noisy environments (Microchip Technology Inc. 1992).

Once the initiation process is completed, the controller monitors the timing signal input line to determine when baseline adjustment is appropriate. After the measurement system has entered a background-only phase, the controller initiates an ADC and reads in the current value of the feedback signal. If this feedback signal matches the preprogrammed target value, then background adjustment is not required. If the feedback signal is found to deviate from the target value, the controller then determines the sense of the deviation and increases or decreases the magnitude of the differential signal as appropriate. This differential signal adjustment process is repeated a preset number of times that depend on the time interval available and the estimated maximum background drift. The initialization routine is then reentered, and the entire process is repeated as a free running loop.

4. A Performance Example

Figure 6 illustrates an example of the BAD's performance. The upper oscilloscope trace displays a collection of repetitive, narrow rectangular pulses superimposed on a relatively low-frequency ramped-sawtooth waveform. For the purposes of this example, the narrow pulses represent the desired signal that is to be recovered and the broad sawtooth mimics a drifting background that is to be eliminated. The middle trace shows the independent measurement of this background signal as it is fed into the feedback signal input of the BAD. An appropriate timing signal is supplied to the BAD's timing input that triggers the BAD to update the magnitude of its differential output signal every 20 mS. This differential signal is routed to one input of a differential amplifier while the signal shown in the upper trace is routed to the other input. The output from the differential amplifier, which is the difference between its two inputs, is shown by the bottom trace. The low-frequency sawtooth background signal is effectively

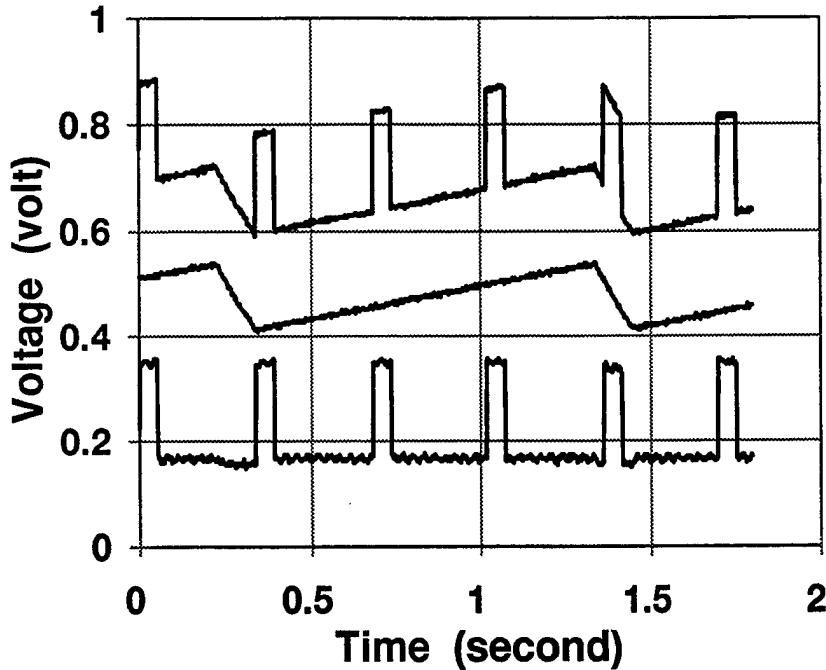

Figure 6. Example of Baseline Adjustment Device Performance.

eliminated. Signal averaging techniques could now be applied to this recovered signal to eliminate the presence of random noise.

5. Conclusions

An automated baseline adjustment device has been presented that can simplify the measurement of small signals that are combined with a drifting background signal and random noise. Although developed to assist with the measurement of IR emissions from gaseous media, this system can be applied generally to systems that offer an independent measurement of the background level. The required hardware has been presented in increasing complexity beginning with an overview of the instrument's functions and progressing through a complete description of the electronic circuitry and its logic. Similarly, the software that drives the embedded controller is presented as a flowchart, explained in detail, and listed in the Appendix.

6. References

Microchip Technology Inc. *Microchip Data Book*. Second edition, Chandler, AZ, 1992.

Moore, J. H., C. C. Davis, and M. A. Coplan. *Building Scientific Apparatus*. Reading, MA: Addison-Wesley Publishing Co., Inc., 1983.

National Semiconductor Company. *Linear Databook 2*. Santa Clara, CA, 1988 edition.

National Semiconductor Company. *Data Acquisition Databook*. Santa Clara, CA, 1993 edition.

INTENTIONALLY LEFT BLANK.

Appendix:
PIC16C55 Controller Software Listing

INTENTIONALLY LEFT BLANK.

```
; IR FLUORESCENCE BASELINE ADJUSTMENT DRIVER
; PROGRAM FOR PIC16C55 MICROCONTROLLER
```

```
; VERSION 3.0 JULY 1997
; WRITTEN FOR ASSEMBLY BY MICROCHIP TECHNOLOGY MPALC
; MACRO ASSEMBLER.
```

```
; IF YOU HAVE ANY QUESTIONS ABOUT THIS SOFTWARE CONTACT:
;   Dr. Thomas W. Kottke
;   AMSRL-WM-WD
;   Army Research Laboratory
;   Aberdeen Proving Ground, MD 21005
;   tel: (410) 278-2557
;   fax: (410) 278-9969
;   e-mail: kottke@arl.army.mil
```

```
;***** EQUATE VALUES *****
```

```
;----- CONSTANT DEFINITIONS -----
W          EQU          0x00          ;direct action result
; to W
F          EQU          0x01          ;direct action result
; to F##
Target     EQU          b'01100000'  ;target differential
; op amp output
NumCor     EQU          b'00011000'  ;# correction steps
```

```
;----- BIT DEFINITIONS -----
CarryBit   EQU          0x00          ;carr flag of
; Status regist
ZeroBit    EQU          0x02          ;zero flag of Status
; register
DACWrite   EQU          0x00          ;bit 0 of HandShake
ADCRead    EQU          0x01          ;bit 1 of HandShake
ADCWrite   EQU          0x02          ;bit 2 of HandShake
Trigger    EQU          0x03          ;bit 3 of HandShake
```

```
;----- REGISTER DEFINITIONS -----
Status     EQU          0x03          ;status register, R3
HandShake  EQU          0x05          ;handshaking reg, R5
ADCInput   EQU          0x06          ;ADC input reg, R6
DACOutput  EQU          0x07          ;DAC output reg, R7
Looper     EQU          0x08          ;interval delay
; counter reg, R8
ADCValue   EQU          0x09          ;ADC value reg, R9
DACValue   EQU          0x0A          ;DAC value reg, R10
```

```

LoopCor    EQU          0x0B          ;correction
; counter reg.      R11
PrevVal    EQU          0x0C          ;previous value    R12

```

```

;***** MACRO DIRECTORY *****

```

```

;SetTRIS   defines I/O pin directions
;SetOPTION set prescalar options
;Standby   place 16C55 in standby mode
;InputVolt reads in voltage via ADC
;OutputVolt sources voltage via DAC

```

```

;***** MACRO LISTINGS *****

```

```

SetTRIS    MACRO                                ;MACRO to set I/O
; directions
;0=output  1=input
            MOVLW      b'1000'                  ;define HandShake
; template
            TRIS       HandShake                ;load R5 TRIS reg
;
            MOVLW      b'11111111'             ;def ADCInput
; template
            TRIS       ADCInput                 ;load R6 TRIS reg
;
            MOVLW      b'00000000'             ;def DACOutput
; template
            TRIS       DACOutput                ;load R7 TRIS reg
;
            ENDM                                  ;end of MACRO

```

```

;-----
SetOPTION  MACRO                                ;MACRO to set
; prescalar options
            MOVLW      b'00111111'             ;def OPTION template
OPTION     ;load OPTION register
;
            ENDM                                  ;end of MACRO

```

```

;-----
Standby    MACRO                                ;MACRO to place 16C55
; in standby mode
            SetTRIS    ;set I/O directions
            SetOPTION  ;set prescalar
; options
            BSF        HandShake,DACWrite;set DACWrite high
            BSF        HandShake,ADCRead ;set ADCRead high

```

```

BSF          HandShake,ADCWrite;set ADCWrite
             ; high

CLRWDI      ;clear watch dog
; timer

ENDM        ;end of MACRO

;-----
InputVolt   MACRO                                ;MACRO to read in a
                                                ;voltage from ADC

LOCAL      InputVolt1                          ;define location
LOCAL      InputVolt2                          ;define location
BCF        HandShake,ADCWrite;pull ADCWrite low
MOVLW     b'00010000'                          ;load W with value
MOVWF     Looper                               ;transfer W to Looper
InputVolt1 DECFSZ   Looper,F                    ;decr Looper, =0 ?
GOTO      InputVolt1                          ;(no) go to In..Volt1
BSF       HandShake,ADCWrite;(yes)pull ADCWrite
             ; high
MOVLW     b'11111111'                          ;load W with value
MOVWF     Looper                               ;transfer W to Looper
InputVolt2 DECFSZ   Looper,F                    ;decr Looper, =0 ?
GOTO      InputVolt2                          ;(no) go to In..Volt2
BCF       HandShake,ADCRead ;(yes) pull ADCRead
             ; low
NOP       ;settling delay
NOP
NOP
MOVF      ADCInput,W                          ;move ADCInput to W
MOVWF     ADCValue                            ;move W to ADCValue
BSF       HandShake,ADCRead ;pull ADCRead high

ENDM      ;end of MACRO

;-----
OutputVolt  MACRO                                ;MACRO to source a
                                                ;voltage through DAC

LOCAL      OutVolt1                            ;define location
MOVF      DACValue,W                          ;move DACValue to W
MOVWF     DACOutput                            ;move W to DACOutput
BCF       HandShake,DACWrite;pull DACWrite low
MOVLW     b'00010000'                          ;load W with value
MOVWF     Looper                               ;move W to Looper
OutVolt1  DECFSZ   Looper,F                    ;decr Looper, =0 ?
GOTO      OutVolt1                            ;(no) go to OutVolt1
BSF       HandShake,DACWrite;pull DACWrite high

```

ENDM

;end of MACRO

***** SOURCE CODE *****

```
NotReady    Standby                ;MACRO
            BTFSC      HandShake,Trigger ;trigger line clear?
            GOTO      NotReady          ;(no) go to NotReady
Ready       BTFSS      HandShake, Trigger;(yes) trig line set?
            GOTO      Ready             ;(no) go to Ready
            MOVLW     NumCor            ;(yes) load W
            MOVWF     LoopCor           ;move W to Looper
Correct     InputVolt              ;MACRO
            MOVLW     Target            ;load W with Target
            ; value
            SUBWF     ADCValue,W        ;sub W from ADCValue
            BTFSC     Status,ZeroBit    ;result=0 ?
            GOTO      Check            ;(yes) go to Check
            BTFSS     Status,CarryBit    ;(no) result<0 ?
            GOTO      IncDAC            ;(yes) go to IncDAC
            GOTO      DecDAC            ;(no) go to DecDAC
IncDAC      MOVF       DACValue,W        ;move DACValue to W
            MOVWF     PrevVal           ;move W to PrevValue
            INCF      DACValue,F        ;increment DACValue
            BTFSC     Status,ZeroBit    ;DACValue=0 ?
            GOTO      DACOver           ;(yes) go to DACOver
            GOTO      DACNoOver        ;(no) go to DACNoOver
DACOver     MOVLW     b'11111111'       ;load W with 255
            MOVWF     DACValue          ;move W to DACValue
DACNoOver   OutputVolt              ;MACRO
            GOTO      Check            ;jump
DecDAC      MOVF       DACValue,W        ;move DACValue to W
            MOVWF     PrevVal           ;move W to PrevValue
            DECF      DACValue,F        ;decrement DACValue
            MOVLW     b'11111111'       ;load W with 255
            SUBWF     DACValue,W        ;sub W from DACValue
            BTFSC     Status,ZeroBit    ;DACValue=255 ?
            GOTO      DACUnder         ;(yes) go to DACUnder
            GOTO      DACNoUnder       ;(no) goto DACNoUnder
DACUnder    CLRF      DACValue          ;set DACValue=0
DACNoUnder  OutputVolt              ;MACRO
Check       DECFSZ    LoopCor           ;Dec LoopCor, =0 ???
```

```

GOTO      Correct          ;(no) go to Correct

MOVWF    PrevVal,W        ;(yes) move PrevVal
                        ; to W

SUBWF    DACValue,W       ;subt W from DACVal
BTFSS    Status,CarryBit  ;is carry bit set ??
GOTO     NotReady        ;(no) go to NotReady
MOVWF    PrevVal,W       ;(yes) move PrevVal
                        ; to W

MOVWF    DACValue        ;move W to DACValue
OutputVolt
GOTO     NotReady        ;go to NotReady
END      ;end of code

```

INTENTIONALLY LEFT BLANK.

<u>NO. OF COPIES</u>	<u>ORGANIZATION</u>
2	DEFENSE TECHNICAL INFORMATION CENTER DTIC DDA 8725 JOHN J KINGMAN RD STE 0944 FT BELVOIR VA 22060-6218
1	HQDA DAMO FDQ D SCHMIDT 400 ARMY PENTAGON WASHINGTON DC 20310-0460
1	OSD OUSD(A&T)/ODDDR&E(R) R J TREW THE PENTAGON WASHINGTON DC 20301-7100
1	DPTY CG FOR RDE HQ US ARMY MATERIEL CMD AMCRD MG CALDWELL 5001 EISENHOWER AVE ALEXANDRIA VA 22333-0001
1	INST FOR ADVNCD TCHNLGY THE UNIV OF TEXAS AT AUSTIN PO BOX 202797 AUSTIN TX 78720-2797
1	DARPA B KASPAR 3701 N FAIRFAX DR ARLINGTON VA 22203-1714
1	NAVAL SURFACE WARFARE CTR CODE B07 J PENNELLA 17320 DAHLGREN RD BLDG 1470 RM 1101 DAHLGREN VA 22448-5100
1	US MILITARY ACADEMY MATH SCI CTR OF EXCELLENCE DEPT OF MATHEMATICAL SCI MAJ M D PHILLIPS THAYER HALL WEST POINT NY 10996-1786

<u>NO. OF COPIES</u>	<u>ORGANIZATION</u>
1	DIRECTOR US ARMY RESEARCH LAB AMSRL DD J J ROCCHIO 2800 POWDER MILL RD ADELPHI MD 20783-1145
1	DIRECTOR US ARMY RESEARCH LAB AMSRL CS AS (RECORDS MGMT) 2800 POWDER MILL RD ADELPHI MD 20783-1145
3	DIRECTOR US ARMY RESEARCH LAB AMSRL CI LL 2800 POWDER MILL RD ADELPHI MD 20783-1145
	<u>ABERDEEN PROVING GROUND</u>
4	DIR USARL AMSRL CI LP (305)

NO. OF
COPIES ORGANIZATION

ABERDEEN PROVING GROUND

18 DIR USARL
AMSRL WM TE
A NIILER
D DANIEL
P BERNING
J CORRERI
W GARDINER
C HOLLANDSWORTH
C HUMMER
L KECSKES
T KOTTKE
K MAHAN
M MCNEIR
D PERRY
J POWELL
A PRAKASH
S ROGERS
H SINGH
C STUMPFEL
G THOMSON

REPORT DOCUMENTATION PAGE			Form Approved OMB No. 0704-0188	
Public reporting burden for this collection of information is estimated to average 1 hour per response, including the time for reviewing instructions, searching existing data sources, gathering and maintaining the data needed, and completing and reviewing the collection of information. Send comments regarding this burden estimate or any other aspect of this collection of information, including suggestions for reducing this burden, to Washington Headquarters Services, Directorate for Information Operations and Reports, 1215 Jefferson Davis Highway, Suite 1204, Arlington, VA 22202-4302, and to the Office of Management and Budget, Paperwork Reduction Project(0704-0188), Washington, DC 20503.				
1. AGENCY USE ONLY (Leave blank)	2. REPORT DATE June 1999	3. REPORT TYPE AND DATES COVERED Final, Jan 97 - May 98		
4. TITLE AND SUBTITLE A Simple Digital Method for Compensation of Baseline Drift in Low-Frequency Small-Signal Waveform Measurements		5. FUNDING NUMBERS 18AH80		
6. AUTHOR(S) Thomas Kottke, David M. Perry, and George M. Thomson				
7. PERFORMING ORGANIZATION NAME(S) AND ADDRESS(ES) U.S. Army Research Laboratory ATTN: AMSRL-WM-TE Aberdeen Proving Ground, MD 21005-5066		8. PERFORMING ORGANIZATION REPORT NUMBER ARL-MR-446		
9. SPONSORING/MONITORING AGENCY NAMES(S) AND ADDRESS(ES)		10. SPONSORING/MONITORING AGENCY REPORT NUMBER		
11. SUPPLEMENTARY NOTES				
12a. DISTRIBUTION/AVAILABILITY STATEMENT Approved for public release; distribution is unlimited.		12b. DISTRIBUTION CODE		
13. ABSTRACT (Maximum 200 words) The need to measure relatively small signals mixed with drifting background levels and random noise is a common requirement in the laboratory environment. This report presents a simple device that continuously compensates for drifting baseline levels in systems where the background can be measured independently. The resulting level of automation allows the effects of random noise to be diminished through extensive signal averaging. For added flexibility, parameters such as the input voltage range and background sampling rate can be set by the user. All required hardware and software are provided and explained in detail.				
14. SUBJECT TERMS small signal, baseline drift, random noise, signal averaging, differential measurement		15. NUMBER OF PAGES 29		16. PRICE CODE
17. SECURITY CLASSIFICATION OF REPORT UNCLASSIFIED	18. SECURITY CLASSIFICATION OF THIS PAGE UNCLASSIFIED	19. SECURITY CLASSIFICATION OF ABSTRACT UNCLASSIFIED	20. LIMITATION OF ABSTRACT UL	

INTENTIONALLY LEFT BLANK.

USER EVALUATION SHEET/CHANGE OF ADDRESS

This Laboratory undertakes a continuing effort to improve the quality of the reports it publishes. Your comments/answers to the items/questions below will aid us in our efforts.

1. ARL Report Number/Author ARL-MR-446 (Kottke) Date of Report June 1999
2. Date Report Received _____
3. Does this report satisfy a need? (Comment on purpose, related project, or other area of interest for which the report will be used.) _____

4. Specifically, how is the report being used? (Information source, design data, procedure, source of ideas, etc.) _____

5. Has the information in this report led to any quantitative savings as far as man-hours or dollars saved, operating costs avoided, or efficiencies achieved, etc? If so, please elaborate. _____

6. General Comments. What do you think should be changed to improve future reports? (Indicate changes to organization, technical content, format, etc.) _____

CURRENT ADDRESS	_____
	Organization

	Name E-mail Name

	Street or P.O. Box No.

	City, State, Zip Code

7. If indicating a Change of Address or Address Correction, please provide the Current or Correct address above and the Old or Incorrect address below.

OLD ADDRESS	_____
	Organization

	Name

	Street or P.O. Box No.

	City, State, Zip Code

(Remove this sheet, fold as indicated, tape closed, and mail.)
(DO NOT STAPLE)

DEPARTMENT OF THE ARMY

OFFICIAL BUSINESS

BUSINESS REPLY MAIL
FIRST CLASS PERMIT NO 0001,APG,MD

POSTAGE WILL BE PAID BY ADDRESSEE

DIRECTOR
US ARMY RESEARCH LABORATORY
ATTN AMSRL WM TE
ABERDEEN PROVING GROUND MD 21005-5066



NO POSTAGE
NECESSARY
IF MAILED
IN THE
UNITED STATES

