

NAVAL POSTGRADUATE SCHOOL MONTEREY, CALIFORNIA



THESIS

**AN OPTIMIZATION MODEL FOR SEA-BASED SUPPLY
OF BULK FUEL FOR A DEPLOYED MARINE
EXPEDITIONARY UNIT**

by

Harold A. Viado

June 1999

Thesis Advisor:
Second Reader:

R. Kevin Wood
Kevin J. Maher

Approved for public release; distribution is unlimited.

REPORT DOCUMENTATION PAGE

Form Approved
OMB No. 0704-0188

Public reporting burden for this collection of information is estimated to average 1 hour per response, including the time for reviewing instruction, searching existing data sources, gathering and maintaining the data needed, and completing and reviewing the collection of information. Send comments regarding this burden estimate or any other aspect of this collection of information, including suggestions for reducing this burden, to Washington headquarters Services, Directorate for Information Operations and Reports, 1215 Jefferson Davis Highway, Suite 1204, Arlington, VA 22202-4302, and to the Office of Management and Budget, Paperwork Reduction Project (0704-0188) Washington DC 20503.

1. AGENCY USE ONLY (Leave blank)	2. REPORT DATE June 1999	3. REPORT TYPE AND DATES COVERED Master's Thesis
----------------------------------	-----------------------------	---

4. TITLE AND SUBTITLE AN OPTIMIZATION MODEL FOR SEA-BASED SUPPLY OF BULK FUEL FOR A DEPLOYED MARINE EXPEDITIONARY UNIT	5. FUNDING NUMBERS
--	--------------------

6. AUTHOR(S) Harold A. Viado

7. PERFORMING ORGANIZATION NAME(S) AND ADDRESS(ES) Naval Postgraduate School Monterey, CA 93943-5000
--

8. PERFORMING ORGANIZATION REPORT NUMBER
--

9. SPONSORING / MONITORING AGENCY NAME(S) AND ADDRESS(ES)

10. SPONSORING / MONITORING AGENCY REPORT NUMBER
--

11. SUPPLEMENTARY NOTES The views expressed in this thesis are those of the author and do not reflect the official policy or position of the Department of Defense or the U.S. Government.

12a. DISTRIBUTION / AVAILABILITY STATEMENT Approved for public release; distribution is unlimited.

12b. DISTRIBUTION CODE

<p>13. ABSTRACT (maximum 200 words)</p> <p>Operational Maneuver From the Sea (OMFTS) is a Marine Corps concept that shifts the emphasis from blue-water superiority to power projection in the littorals. OMFTS treats the sea as maneuver space, and moves forces directly from ship to objectives ashore with little or no prior build-up of supplies ashore. This thesis develops the Sea-Based Logistic Optimization Model (SBLOM), an integer programming model that assesses the feasibility of conducting sea-based logistics in an OMFTS scenario based on capabilities of current and future assets, e.g., the Landing Craft Air Cushion and the MV-22 Osprey aircraft. SBLOM minimizes (when feasible) the initial fuel requirement of the Marine Expeditionary Unit (Special Operations Capable) (MEU(SOC)) ashore, and develops a fuel-delivery schedule from the sea using the lift assets available on a group of three or four ships known as an Amphibious Readiness Group (ARG). Using two OMFTS scenarios, SBLOM is run with the ARG at stand-off distances of 50, 70, and 100 nautical miles. The scenarios involve a humanitarian mission and an amphibious raid. In all cases, the use of sea-based logistics is feasible: An optimal delivery schedule is developed that meets the daily fuel requirements of the MEU(SOC) and maintains sufficient fuel levels throughout the mission's duration.</p>

14. SUBJECT TERMS Sea-Based Logistics, Operational Maneuver From the Sea, Ship to Objective Maneuver, Class III Supply

15. NUMBER OF PAGES 78

16. PRICE CODE

17. SECURITY CLASSIFICATION OF REPORT Unclassified

18. SECURITY CLASSIFICATION OF THIS PAGE Unclassified
--

19. SECURITY CLASSIFICATION OF Unclassified
--

20. LIMITATION OF ABSTRACT UL

Approved for public release; distribution is unlimited

**AN OPTIMIZATION MODEL FOR SEA-BASED SUPPLY OF BULK FUEL FOR
A DEPLOYED MARINE EXPEDITIONARY UNIT**

Harold A. Viado
Lieutenant, United States Navy
B.S., United States Naval Academy, 1992

Submitted in partial fulfillment of the
requirements for the degree of

MASTER OF SCIENCE IN OPERATIONS RESEARCH

from the

**NAVAL POSTGRADUATE SCHOOL
June 1999**

Author:



Harold A. Viado

Approved by:

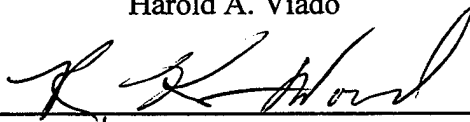

R. Kevin Wood, Thesis Advisor



Kevin J. Maher, Second Reader

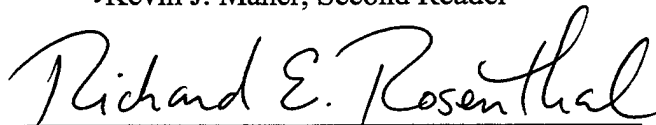

Richard Rosenthal, Chairman
Department of Operations Research

ABSTRACT

Operational Maneuver From the Sea (OMFTS) is a Marine Corps concept that shifts the emphasis from blue-water superiority to power projection in the littorals. OMFTS treats the sea as maneuver space, and moves forces directly from ship to objectives ashore with little or no prior build-up of supplies ashore. This thesis develops the Sea-Based Logistic Optimization Model (SBLOM), an integer programming model that assesses the feasibility of conducting sea-based logistics in an OMFTS scenario based on capabilities of current and future assets, e.g., the Landing Craft Air Cushion and the MV-22 Osprey aircraft. SBLOM minimizes (when feasible) the initial fuel requirement of the Marine Expeditionary Unit (Special Operations Capable) (MEU(SOC)) ashore, and develops a fuel-delivery schedule from the sea using the lift assets available on a group of three or four ships known as an Amphibious Readiness Group (ARG). Using two OMFTS scenarios, SBLOM is run with the ARG at stand-off distances of 50, 70, and 100 nautical miles. The scenarios involve a humanitarian mission and an amphibious raid. In all cases, the use of sea-based logistics is feasible: an optimal delivery schedule is developed that meets the daily fuel requirements of the MEU(SOC) and maintains sufficient fuel levels throughout the mission's duration.

THESIS DISCLAIMER

The reader is cautioned that computer programs developed in this research may not have been exercised for all cases of interest. While every effort has been made, within the time available, to ensure that the program is free of computational and logic errors, it cannot be considered validated. Any application of this program without additional verification is at the risk of the user.

TABLE OF CONTENTS

1.	INTRODUCTION	1
A.	PURPOSE	1
B.	BACKGROUND.....	2
C.	PROBLEM DESCRIPTION AND ASSUMPTIONS	5
D.	OUTLINE	8
II.	MODEL FORMULATION	9
A.	GENERAL DESCRIPTION	9
B.	FUEL NETWORK.....	10
C.	LIFT NETWORK	11
D.	FORMULATION.....	14
1.	Indices	14
2.	Subsets	14
3.	Data	14
4.	Variables	15
5.	Mathematical Formulation.....	16
E.	DESCRIPTION OF THE FORMULATION	17
F.	RELATED RESEARCH	19
III.	COMPUTATIONAL RESULTS.....	21
A.	FUEL DEMAND DATA	21
B.	LIFT NETWORK DATA	21
1.	MV-22 Osprey	21

2.	Landing Craft Air Cushion (LCAC).....	22
3.	LVS and 5-TON.....	23
C.	FIRST SCENARIO, A HUMANITARIAN MISSION.....	24
D.	RESULTS OF FIRST SCENARIO	27
E.	SECOND SCENARIO, AN AMPHIBIOUS RAID.....	30
F.	RESULTS OF SECOND SCENARIO.....	32
G.	ADDITIONAL MODEL RUNS.....	35
IV.	CONCLUSIONS	39
A.	OVERVIEW	39
B.	SUGGESTED MODEL IMPROVEMENTS.....	40
	LIST OF REFERENCES.....	43
	APPENDIX A. FIRST SCENARIO FUEL LEVELS	45
	APPENDIX B. SECOND SCENARIO FUEL LEVELS	51
	INITIAL DISTRIBUTION LIST	61

LIST OF ACRONYMS

AAAV	Advanced Amphibious Assault Vehicle
ACE	Air Combat Element
ARG	Amphibious Readiness Group
BLT	Battalion Landing Team
BSA	Beach Support Area
CSSD	Combat Service Support Detachment
CSSE	Combat Service Support Element
GAMS	General Algebraic Modeling System
GCE	Ground Combat Element
LAR	Light Armored Reconnaissance
LCAC	Landing Craft Air Cushion
LFSP	Landing Force Support Party
LHA	Amphibious Assault Ship (General Purpose)
LHD	Amphibious Assault Ship (Multipurpose)
LPD	Amphibious Transport Dock
LPH	Amphibious Assault Ship (Helicopter)
LSD	Dock Landing Ship
LST	Tank Landing Ship
LZST	Landing-Zone Support Team
LVS	Logistic Vehicle System
MAGTF	Marine Air Ground Task Force
MEU(SOC)	Marine Expeditionary Unit (Special Operations Capable)
OMFTS	Operational Maneuver From the Sea

SBL	Sea-Based Logistics
SBLOM	Sea-Based Logistics Optimization Model
STOM	Ship to Objective Maneuver

EXECUTIVE SUMMARY

With the coming of the 21st century, the United States military is developing new concepts that will allow combat forces to fight with more flexibility and effectiveness. The 20th-century strategy of conducting military operations with a large logistic infrastructure or “footprint” ashore has been abandoned for doctrine that reduces the footprint to make expeditionary forces more mobile and less vulnerable to the enemy. The Marine Corps development concept, *Operational Maneuver From the Sea* (OMFTS), is one example of the new doctrine.

A major issue of OMFTS is the required logistic support for Class III supply (bulk fuel). In past amphibious operations, the Marine Corps relied on the Navy’s tank landing ships (LSTs) to anchor offshore and pump fuel directly to shore. Once on shore, Marines from an engineer support battalion would receive the fuel and either store the fuel inland or make it available for tactical distribution. The recent decommissioning of all LSTs has raised the issue of how the Navy and Marine Corps team will provide fuel in support of the OMFTS concept. This thesis develops the Sea-Based Logistic Optimization Model (SBLOM), an integer programming model, to explore the feasibility of sea-based logistic support of Class III supply in an OMFTS scenario.

SBLOM is a mixed-integer program generated using GAMS (General Algebraic Modeling System) that determines the fuel inventory and delivery requirements for a Marine Expeditionary Unit (Special Operations Capable) (MEU(SOC)) unit deployed from a group of three or four ships known as an Amphibious Readiness Group (ARG). The objective of SBLOM is to minimize the initial fuel supply that must be established ashore prior to commencement of operations and to develop a just-in-time fuel-delivery

schedule to sustain the combat forces ashore. SBLOM models fuel delivery from the ARG to landing zones using air-cushion landing craft or MV-22 Osprey aircraft. Then, at the landing zones, SBLOM transfers fuel to inventory or sends it forward on transport vehicles to meet demands of forward-deployed units of the MEU(SOC).

SBLOM is tested under two hypothetical scenarios based on deterministic consumption rates developed by the Marine Corps. One scenario involves the MEU(SOC) in a humanitarian mission and the other has the MEU(SOC) conducting an amphibious raid. Three ARG stand-off distances (50, 70 and 100 nautical miles) are used for each scenario. In all cases, SBLOM achieves optimal solutions that meet all fuel requirements.

Additional model runs are performed in a sensitivity analysis to identify the limitations of SBLOM and OMFTS. When the ARG stand-off distance is increased to 200 nautical miles, SBLOM is able to achieve a solution when the standard fuel loads of the ship lift assets are increased. Even at 200 nautical miles, the OMFTS concept appears to work. However, this distance places a heavy reliance on the MV-22 Osprey aircraft whose number of sorties increases significantly.

Other areas of analyses include loss of ship-based lift assets and loss of land-based lift assets at the landing zones. Results indicate that the losses at the landing zones are more critical than losses of lift assets on the ships. The overall results from both scenarios and the additional model runs illustrate the flexibility of SBLOM. The model can be further enhanced to provide additional insight into other aspects of OMFTS.

ACKNOWLEDGEMENT

This research was possible due to the efforts of many people. Most notably is that of my wife Racquel for her patience, understanding, love, and support throughout this research and my studies. Sincere thanks go out to my thesis advisor, Professor R. Kevin Wood, and my second reader, Commander Kevin Maher, for their guidance and individual attention that provided me with the tools necessary to put ideas and concepts on paper. I want to thank MS Therese Bilodeau for editing and correcting all figures and tables in this document. I would also like to thank Professor Siriphong Lawphongpanich for a careful reading of this manuscript.

I would also like to thank my fellow classmates in the Operations Analysis/Logistics curriculum especially LT Jeff Jones, LT Karl Werenskjold, and LT Gary Morris for their friendship, laughter, and support. Lastly, I would like to thank my family whose encouragement and love have always inspired me to do my best. I dedicate this thesis to my father who I miss everyday and my son Nicholas who, along with his mother, has given me the most joy out of life.

I. INTRODUCTION

A. PURPOSE

With the coming of the 21st century, the United States military is developing new concepts that will allow combat forces to fight with more flexibility and effectiveness. The 20th-century strategy of conducting military operations with a large logistic infrastructure or “footprint” ashore has been abandoned for doctrine that reduces the footprint to make expeditionary forces more mobile and less vulnerable to the enemy. The Marine Corps’ development concept, *Operational Maneuver From the Sea* (OMFTS), is one example of this new doctrine (Krulak 1996).

The goal of OMFTS is to win battles by landing forces that maneuver from their ships directly to objectives ashore; a large build-up ashore is unnecessary. A key concept in OMFTS is the use of sea-based logistics (SBL) to sustain the combat forces ashore. Because the Marine Corps is currently developing doctrine to support OMFTS, the requirements necessary for executing OMFTS are still unclear.

The purpose of this thesis is to develop a computer-based optimization model to explore the feasibility of sea-based logistic support for bulk fuel, called “Class III Supply,” in an OMFTS scenario. While the Marine Corps’ supply system encompasses nine classes of supply, this thesis examines only Class III; however, the thesis does address the possibility of incorporating other classes of supply at a later date.

The model developed for analysis purposes is the Sea-Based Logistic Optimization Model (SBLOM), which is a mixed-integer program generated using GAMS (General Algebraic Modeling System) (Brooke *et al.* 1992). The objective of SBLOM is to minimize the initial fuel supply that must be established ashore prior to

commencement of operations, and to develop a fuel-delivery schedule to sustain the combat forces ashore. SBLOM is tested under hypothetical scenarios based on deterministic consumption rates developed by the Marine Corps. It allows study of the OMFTS logistic capabilities of new assets such as the Landing Craft Air Cushion (LCAC), the MV-22 Osprey tiltrotor aircraft, and current Marine Corps logistic equipment.

B. BACKGROUND

OMFTS was developed in response to Department of the Navy White Papers, *...From the Sea* (O'Keefe 1992) and *Forward ...From the Sea* (Dalton 1994), which are the governing documents on how U.S. Naval Forces will use command of the seas to gain access and freedom of action in the world's littoral areas. OMFTS describes the rapid maneuver of landing forces from U.S. Navy amphibious ships directly to the objective areas located well inland, with logistic support provided from sea-based logistic assets. This ship-to-objective maneuver (STOM) concept is a break from the traditional, two-phase concept of amphibious assault.

Current amphibious assault doctrine requires the establishment of a Beach Support Area (BSA); see Figure 1. The BSA is constructed by the Landing Force Support Party (LFSP) and serves as the central point for the receipt of supplies, fuel and landing-force equipment. From the BSA, assets of the LFSP carry supplies to the Combat Service Support Detachments (CSSDs) who carry the supplies for each fighting unit. Building and expanding a BSA is very time-consuming and labor-intensive. A BSA may cover hundreds of acres with ammunition dumps, fuel farms, supply depots

and hospitals for the combat forces. This tremendous area increases the vulnerability of the BSA and its logistics infrastructure (Bancroft 1996).

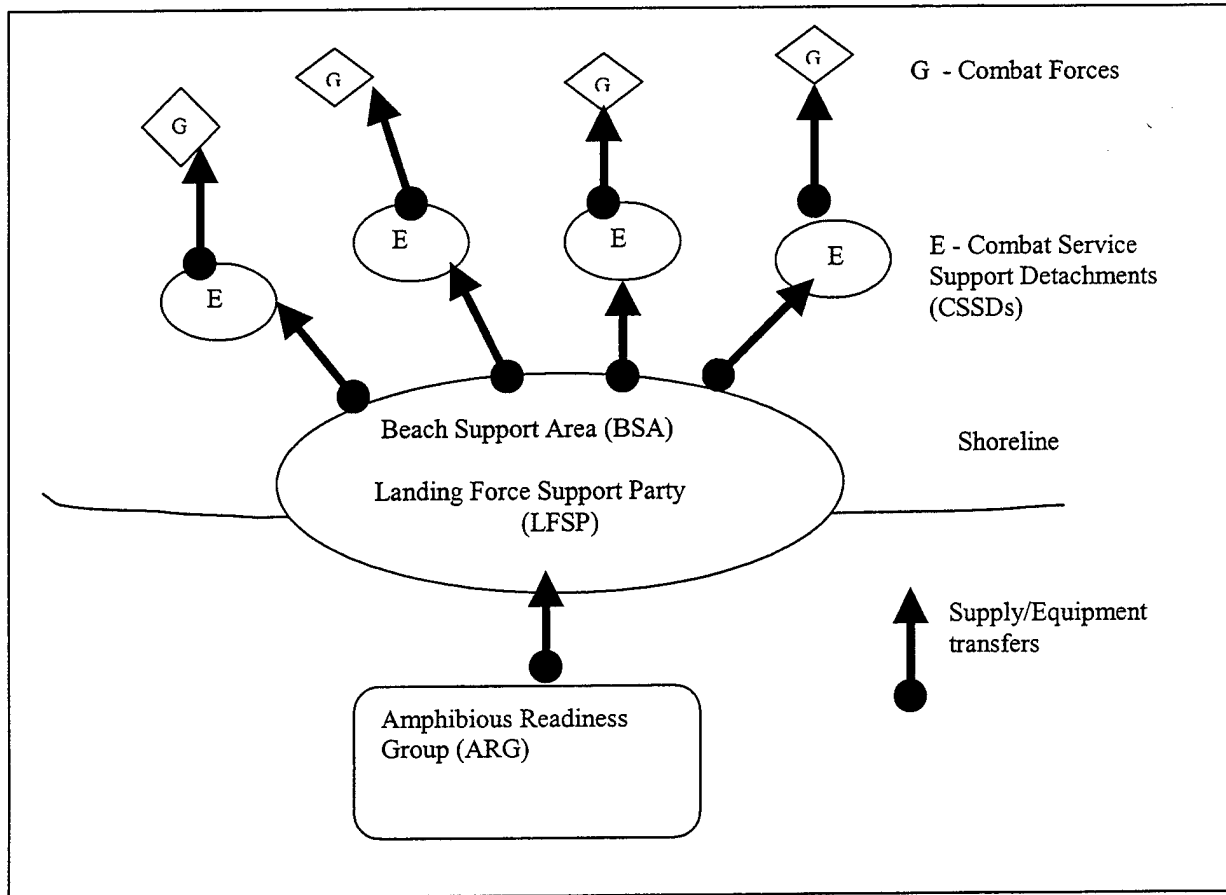

Figure 1. Traditional Amphibious Assault. The traditional amphibious assault requires the establishment of the Beach Support Area (BSA) prior to the landing of supplies and equipment from the Amphibious Readiness Group (ARG). The BSA serves as the drop-off point and delivery origin for all supplies entering theater. Combat Service Support Detachments (CSSDs) deliver the supplies to the forward-deployed units after receipt from the BSA.

OMFTS treats the sea as a means of gaining advantage over the enemy and as a barrier to the enemy. STOM is a vital concept of OMFTS that eliminates the BSA by sending landing forces directly from their ships to their objectives with little or no logistic infrastructure ashore. An essential component of STOM is the use of sea-based logistics. The sea-basing concept calls for ships of the amphibious readiness group (ARG) to serve

as floating combat-service support platforms to sustain the combat forces ashore; see Figure 2. Using sea-based supply sources and assets, landing-force vulnerability and footprint ashore are reduced, enabling the naval force to project ashore combat forces that are lighter, more mobile and more effective (Van Riper 1998).

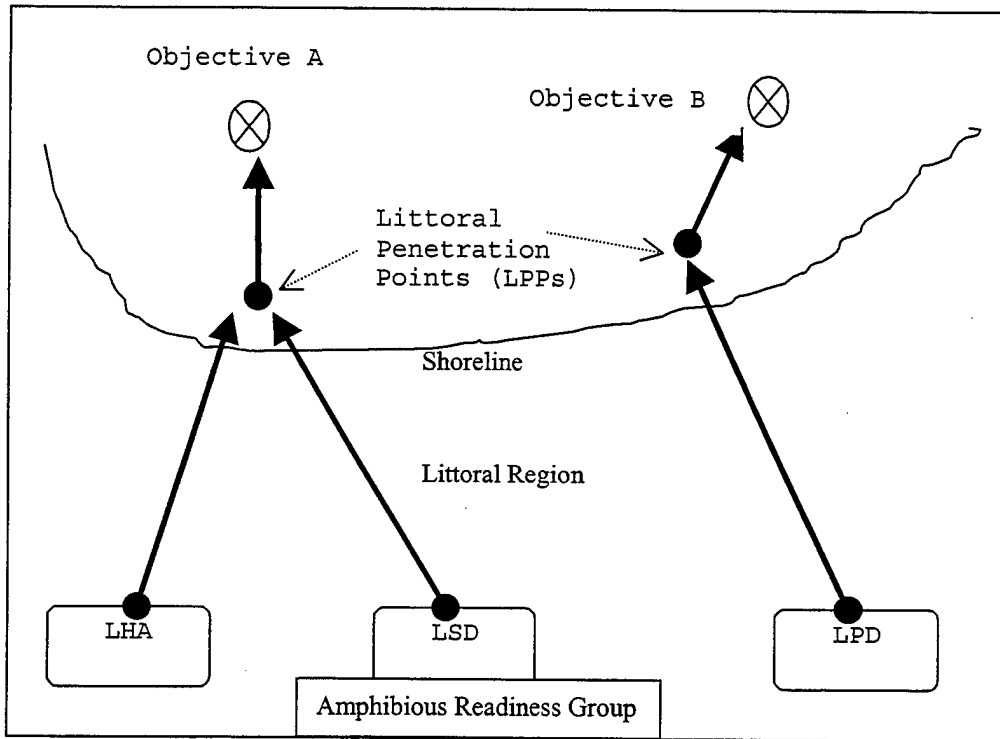

Figure 2. OMFTS Assault. Landing forces move from their ships to the objectives ashore via designated Littoral Penetration Points (LPPs). The large build-up of supplies ashore is unnecessary.

A major issue of OMFTS is the required logistic support for fuel, called “Class III supply.” In past amphibious operations, the Marine Corps relied on the Navy’s tank landing ships (LSTs) to anchor offshore and set up a floating fuel hose to pump fuel from the LST to shore. Once on shore, Marines from the engineering support battalion would receive the fuel and either store the fuel inland or make it available for tactical distribution. The recent decommissioning of all LSTs has raised the issue of how the Navy and Marine Corps team will provide fuel in support of the OMFTS concept

(Skipper 1997). This thesis investigates the feasibility of providing fuel through the use of sea-based logistic support and landing-zone support teams (LZSTs).

C. PROBLEM DESCRIPTION AND ASSUMPTIONS

This thesis is limited to a Marine Expeditionary Unit (Special Operations Capable) (MEU(SOC)) deployed from an amphibious readiness group conducting one of its 18 assigned missions or tasks (United States Marine Corps 1997). The possible amphibious ships within an ARG are:

- 1 = LHA-1 (Tarawa Class)
- 2 = LHD-1 (Wasp Class)
- 3 = LPH-2 (Iwo Jima Class)
- 4 = LPD-1 (Raleigh Class)
- 5 = LPD-4 (Austin Class)
- 6 = LSD-36 (Anchorage Class)
- 7 = LSD-41 (Whidbey Island Class)
- 8 = LSD-49 (Harpers Ferry Class)

A MEU(SOC) is one of three Marine Air Ground Task Forces (MAGTFs). The Marine Corps maintains seven MEU(SOC)s around the globe. A MEU(SOC) is the ideal MAGTF for analysis with SBLOM because it is the primary deploying force that will operate in an OMFTS environment. A MEU(SOC) consists of the following elements: Command Element (CE), Ground Combat Element (GCE), Air Combat Element (ACE), and a Combat Service Support Element (CSSE). This thesis focuses on the GCE of a MEU(SOC) known as the Battalion Landing Team (BLT). The BLT

represents forward-deployed forces in theater and is the primary component of the MEU.

The BLT performs a variety of missions, and its composition depends on the mission. For example, a BLT may be tasked to seize an airfield, assist with disaster relief, or evacuate personnel from an embassy under siege. Normally, a BLT consists of the following units:

- 1 = Infantry Battalion
- 2 = Artillery Battery
- 3 = Tank Platoon
- 4 = Rifle Company
- 5 = Combat Engineer Platoon
- 6 = Advanced Amphibious Assault Vehicle (AAAV) platoon
- 7 = Light Armored Reconnaissance (LAR) Platoon

A BLT receives fuel from nearby established landing zones. These landing zones are maintained by a Landing-Zone Support Team (LZST) and serve as throughput areas for incoming supplies. The LZST performs functions similar to those performed by a shore party team in the BSA. Each landing zone is manned by a small number of personnel and transport equipment to keep its footprint at a minimum. The LZST acts as a forward CSSE unit providing the necessary logistic services and goods to the units it supports (Ivancovich 1991). The importance of the LZST for this thesis is that it provides fuel to the BLT.

It is critical to note that the (indivisible) units of a BLT may be combined into two or more semi-independent “groups,” which operate at some distance from each other. Furthermore, each BLT group receives its fuel and other supplies in separate round-trip

deliveries from the landing zone(s). Complicated routing issues do not arise.

Because of the inherent complexities involved with an amphibious operation, the following assumptions make the problem and SBLOM more manageable:

- SBLOM only takes into account the Ground Combat Element (GCE) of the MEU(SOC). The Air Combat Element (ACE) of the MEU(SOC), is excluded because their assets are sea-based and refuel at sea.
- SBLOM does not directly allow for the uncertain effects of weather, enemy threat, etc., because incorporating these effects would lead to a very complicated model. These factors can be explored with SBLOM on a scenario-by-scenario basis by adjusting time delays and other parameters to reflect delays, loss of lift assets, etc.
- Each lift asset will use a fixed percentage of its lift capacity, on each roundtrip, to carry fuel. (In reality, tradeoffs can be made in the amount of fuel delivered versus the amount of other supplies that are delivered.) For example, an LCAC making a fuel delivery is assumed to carry and deliver exactly 40% of its lift capacity in fuel.
- Consumption rates are deterministic and based on usage rates and planning factors established by the Marine Corps.
- Each ship in the ARG has an unlimited supply of fuel. It is assumed that the ships receive adequate replenishment at sea to prevent fuel shortages.

D. OUTLINE

The thesis is divided into four chapters. In Chapter I the purpose and background are discussed. Chapter II provides a general description and the mathematical formulation of SBLOM. Chapter III describes the test scenarios and summarizes computational results. Chapter IV gives conclusions and recommends future enhancements to SBLOM.

II. MODEL FORMULATION

A. GENERAL DESCRIPTION

Bulk fuel issues for the MEU(SOC) are analyzed using the Sea-Based Logistic Optimization Model (SBLOM). This model is a mixed-integer program that determines the minimum initial level of fuel required at the landing zones and for the groups of the MEU(SOC)'s Battalion Landing Team (BLT). SBLOM also generates an optimal fuel-delivery schedule based on demand and on the composition of assets in the ARG and at the landing zones. The goal is to determine the minimum acceptable amount of fuel prior to the start of an operation to ensure that just-in-time deliveries of fuel can sustain that operation.

The starting points for fuel are the ships that make up the ARG. Fuel flows from the ARG to the landing zones to the BLT groups. Fuel can only be delivered if the amphibious ships and the landing zones have available lift assets. SBLOM allows different ship and lift-asset combinations within the ARG, and at the landing zones, since these can vary depending on scenario.

Conceptually, SBLOM is modeled using two interconnected networks, a fuel network and a lift network. Both networks are expanded by time; time is discretized into hours. Each time-expanded node represents the beginning of each hour during the planning horizon. Multiple copies of nodes in the two networks allow transport platforms to make multiple trips to deliver fuel. Variables linking the two networks ensure that fuel is transferred only if ships and landing zones have on-hand lift assets at appropriate times and sufficient capacity to carry out the transfers.

B. FUEL NETWORK

In the time-expanded fuel network, nodes represent both the landing zones and the BLT groups located onshore, replicated over time. Nodes, and thus flow-balance constraints, are not created to represent ships in the ARG because the ARG is assumed to have an infinite supply of fuel. Arcs in the fuel network are of two types, transportation arcs and inventory arcs. Transportation arcs represent potential shipments of fuel between nodes and the times that these shipments can occur. Inventory arcs represent on-hand fuel, at the landing zones and BLT, carried forward from one time period to the next. An example of the fuel network is shown in Figure 3.

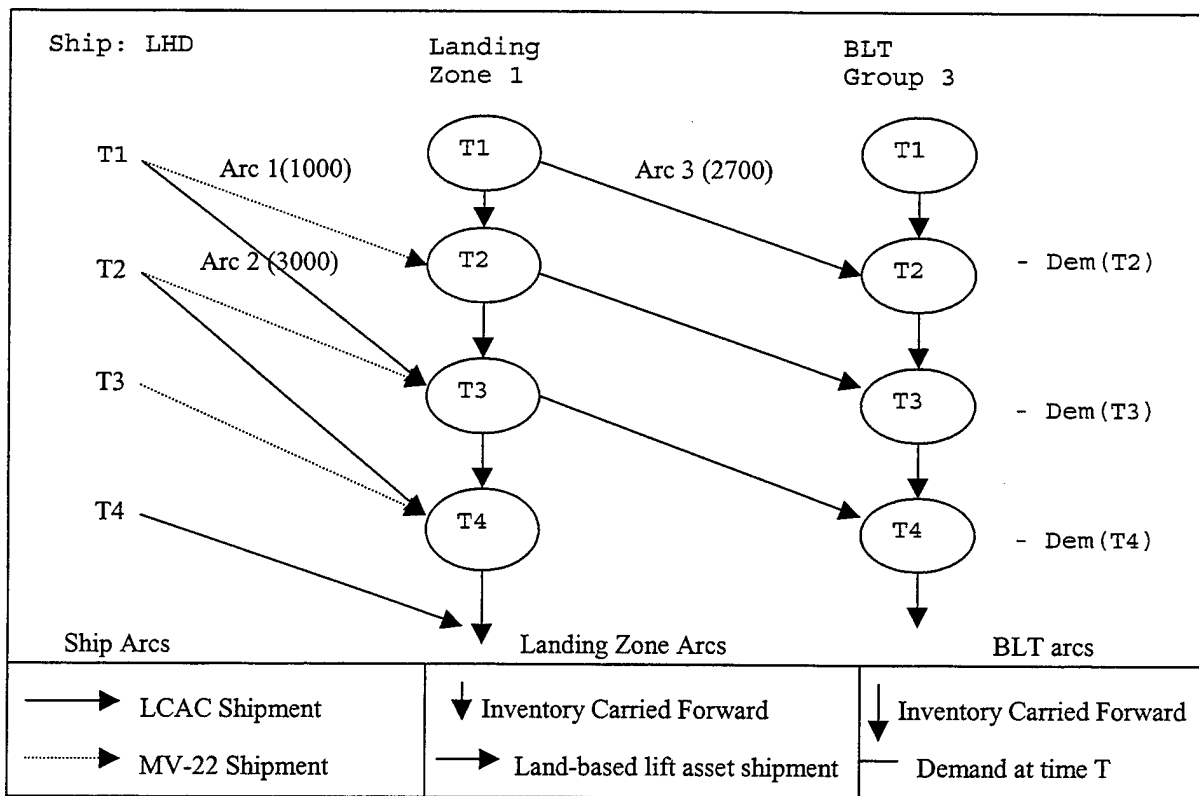

Figure 3 . Example of the Fuel Network. At time period 1, two different assets leave the LHD ship to deliver fuel to landing zone 1: An MV-22 with 1000 gallons of fuel arrives at landing zone 1 at time period 2 (Arc 1) and an LCAC with 3000 gallons of fuel arrives at time period 3 (Arc 2). Arcs 1 and 2 are one-ended and represent potential fuel shipments from the LHD, which is assumed to have an infinite supply of fuel. Arc 3 represents a land-based lift delivering fuel from the landing zone to BLT group 3.

In a standard network flow model, each fuel transportation arc would be represented by a separate variable. For instance, Y_{ijht} might represent the gallons of fuel moving from location i to location j , transported by asset type h , and starting at time t . (Note: The notation used in this paragraph for explanatory purposes is similar to, but not the same as the notation used to define SBLOM.) Since one or more lift assets are necessary to carry that fuel, there will be a one-to-one correspondence between Y_{ijht} and some lift-asset variable, say X_{ijht} . Here, X_{ijht} represents the number of lift assets of type h moving from i to j starting at time t . If the fuel capacity of the lift asset is F_h gallons, then we also need to add a constraint like $Y_{ijht} \leq F_h X_{ijht}$ because fuel cannot flow unless sufficient lift-asset capacity is available to transport it. In SBLOM, however, we assume that every lift asset of type h carries a “standard fuel load” of exactly F_h gallons, which corresponds to a fixed fraction of the asset’s maximum fuel-transporting capacity. With this assumption, $Y_{ijht} \leq F_h X_{ijht}$ may be replaced by $Y_{ijht} = F_h X_{ijht}$. In lieu of adding these equality constraints, the term $F_h X_{ijht}$ may be substituted for Y_{ijht} wherever that variable appears. This is, in essence, what we do in SBLOM. So, we say that the fuel transportation arcs are “implicit,” i.e., they are represented by lift-asset variables (which correspond to arcs in a “lift network”).

C. LIFT NETWORK

In the sense of a multi-commodity flow model, the lift network is actually a collection of networks, or “sub-networks,” representing flows of several different commodities. Nodes are location/asset-type pairs, expanded by time, which represent supply points. A commodity sub-network enables the flow of a specific lift-asset type over a particular round-trip route. For instance, there is one sub-network corresponding

to LCACs making round trips from a particular ship in the ARG and one sub-network corresponding to tanker vehicles making overland, round-trip deliveries of fuel from a landing zone to one or more BLT groups. Each sub-network also contains inventory arcs that can carry unused lift assets from one time period to the next. These inventories are assumed to exist at the ships for the sea-based lift assets and at the landing zones for the land-based lift assets. Figure 4 gives an example of two ship lift sub-networks; note how the roundtrip time for the LCAC is longer than for the MV-22 Osprey.

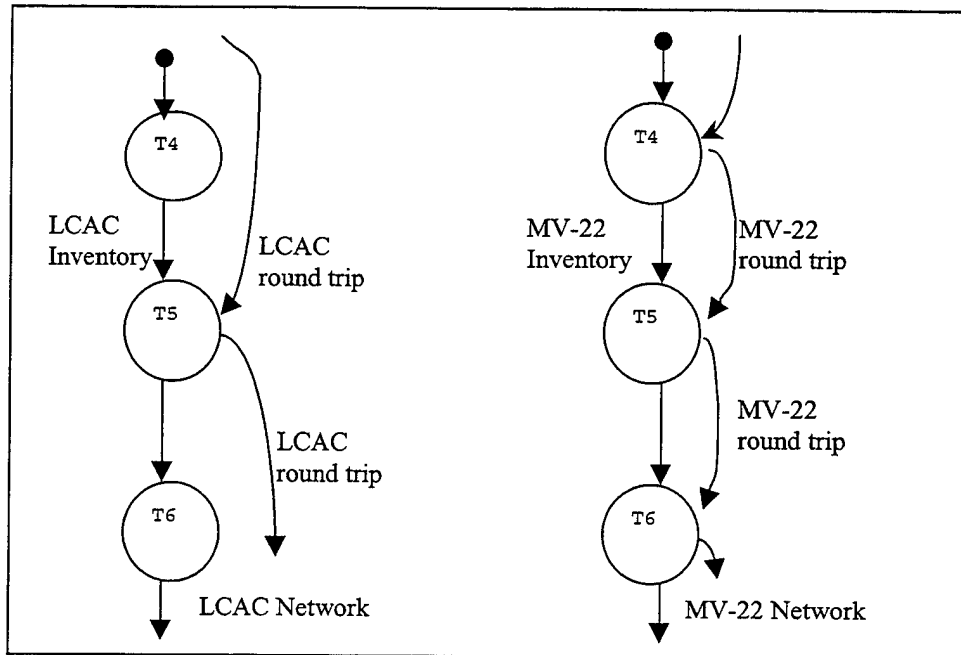

Figure 4. Ship Lift Sub-Networks. Ships control two sea-based lift-asset types, the LCAC (Landing Craft Air Cushion) and MV-22 Osprey, so there are two separate sub-networks. The round-trip time for an MV-22 is one time period here but is at least two time periods for an LCAC.

For the ship lift sub-networks, the following sea-based lift assets are assumed to be available to transport fuel from ship to landing zone:

- 1 = Landing Craft, Air Cushion (LCAC)
- 2 = MV-22 Osprey

Each amphibious ship type has a different sea-based lift-asset configuration. The datum Ml_{ah} represents the initial number of sea-based lift assets of type h loaded on ship a at time period one. The variable Xl_{ahzt} represents the number of assets of type h that begin their trips from ship a to landing zone z at time t . Because the sea-based lift assets make round trips, Xl_{ahzt} also represents the number of sea-based lift assets returning to ship a at a later time period.

At landing zone z , Xl_{ahzt} assets arrive at time $t + Tl_{ahz}$, where Tl_{ahz} represents ship-to-shore travel time plus the time to unload fuel. All travel times, loading times and unloading times are rounded to the nearest hour as required by SBLOM's time discretization. These same sea-based lift assets return to ship a at time $t + Tl_{ahz} + Rl_{ahz}$. The term Rl_{ahz} represents the time for asset type h to return to ship a , refuel, and be ready for another round trip.

For the landing-zone sub-networks, the following land-based lift assets are assumed available to transport fuel from landing zones to the BLT groups:

- 1 = Mk48/14 Logistic Vehicle System (LVS)
- 2 = M818 5-ton tractor

At time period one, it is assumed that landing zone z has $M2_{zs}$ assets on-hand and ready to transport (if fuel is available). The variable $X2_{zsb}$ represents the number of land-based lift assets of type s moving from landing zone z to BLT group b at time t and the number of assets returning at time $t + T2_{zsb} + R2_{zsb}$. $T2_{zsb}$ is the number of hours required to transit from landing zone z , reach group b and unload. $R2_{zsb}$ is the time required for the corresponding return trip.

The constants Tl_{ahz} and $T2_{zsb}$ are based on the average cruising speed of the relevant lift asset plus the average amount of time used to unload fuel. Also associated

with each lift asset is the constant Fl_{ah} or $F2_{zs}$. This represents the standard fuel load for the specified lift asset. For instance, an LCAC can deliver up to 8000 gallons of fuel, but for SBLOM, an LCAC is assumed to use only 37.5% of its maximum fuel-transporting capacity. (It will carry six 500-gallon bladders, although it could carry up to sixteen.) Therefore, Fl_{ah} is 3000 gallons for an LCAC.

D. FORMULATION

SBLOM is stated mathematically as follows:

1. Indices

$a \in A$	amphibious ships
$h \in H$	lift assets on amphibious ships
$z \in Z$	landing zones
$s \in S$	landing-zone lift assets
$b \in B$	battalion landing team groups
$t \in T$	time in hours

2. Subsets

$A_z \subseteq A$	amphibious ships that can send assets to landing zone z
$H_a \subseteq H$	lift assets associated with ship a
$Z_b \subseteq Z$	landing zones that can send lift assets to BLT group b
$S_z \subseteq S$	landing zone lift assets that are located at landing zone z

3. Data

Tl_{ahz}	time in hours for asset h to travel to and unload fuel at a landing zone z
------------	--

$T2_{zsb}$	time in hours for asset s to travel and unload fuel at BLT unit b
$R1_{ahz}$	time in hours for asset h to return from landing zone z , refuel, and reload for a return trip
$R2_{zsb}$	time in hours for asset s to return from BLT unit b , refuel, and reload for a return trip
$F1_{ah}$	standard fuel load (gallons) transported by asset h onboard ship a
$F2_{zs}$	standard fuel load (gallons) transported by asset s at landing zone z
N	fuel inventory requirement (gallons) at the beginning of each day at each landing zone and BLT ($N = 1000$ in all tests)
$M1_{ah}$	initial inventory of asset h onboard ship a
$M2_{zs}$	initial inventory of asset s at landing zone z
Dem_{bt}	demand for fuel by BLT group b at time t
G_s	operating fuel consumption of asset s in gallons per hour
L_b	total daily fuel requirement for BLT group b
β	constant applied to L_b to set maximum fuel inventory levels at all BLT groups and landing zones ($\beta = 3$)
α_t	small, artificial shipping cost per gallon of fuel at time t
Ω	“round-trip movement factor” for lift assets; this is twice the fraction of time that a lift asset is actually moving in making a one-way transit ($\Omega = 2(.8) = 1.6$ in all tests)

4. Variables

$I1_{ah}$	Inventory of asset type h onboard ship a at time t
$X1_{ahzt}$	number of asset type h from ship a sent to landing zone z at time t

$I2_{zst}$	Inventory of asset type s at landing zone z at time t
$X2_{zsb}$	number of asset type s from landing zone z sent to BLT group b at time t
DOS_z	initial supply of fuel, in gallons, at landing zone z
DOS_b	initial supply of fuel, in gallons, at BLT group b
$K1_{zt}$	inventory of fuel (gallons) at landing zone z at time t
$K2_{bt}$	inventory of fuel (gallons) at BLT group b at time t

5. Mathematical Formulation

$$\begin{aligned} \text{Min } & \sum_z DOS_z + \sum_b DOS_b + \sum_a \sum_h \sum_z \sum_t \alpha_t F1_{ah} X1_{ahzt} \\ & + \sum_z \sum_s \sum_b \sum_t \alpha_t F2_{zs} X2_{zsb} \end{aligned} \quad (1)$$

$$I1_{ah,t} - I1_{ah,t-1} + \sum_z X1_{ahzt} - \sum_z X1_{ahzt-T1_{ahz}-R1_{ahz}} = 0 \quad \forall a, h \in H_a, t$$

(Amphibious-ship lift-asset flow-balance constraints)

$$I2_{zst} - I2_{zst-1} + \sum_b X2_{zsb} - \sum_b X2_{zsb-T2_{zsb}-R2_{zsb}} = 0 \quad \forall z, s \in S_z, t$$

(Landing-zone lift-asset flow-balance constraints)

$$\begin{aligned} K1_{zt} - DOS_z + \sum_b \sum_s F2_{zs} X2_{zsb} \\ + \sum_b \sum_s \Omega T2_{zsb} G_s X2_{zsb} = 0 \end{aligned} \quad \forall z, t = 1$$

(Fuel flow-balance constraint for landing zones at $t = 1$)

$$\begin{aligned} K1_{zt} - K1_{zt-1} - \sum_{h \in H_a} F1_{ah} X1_{ahzt-T1_{ahz}} + \sum_s \sum_b F2_{zs} X2_{zsb} \\ + \sum_s \sum_b \Omega T2_{zsb} G_s X2_{zsb} = 0 \end{aligned} \quad \forall z, t > 1$$

(Fuel flow-balance equation for landing zones $t > 1$)

$$K2_{bt} - DOS_b = -Dem_{bt} \quad \forall b, t = 1$$

(Fuel flow-balance constraint for BLT groups at $t = 1$)

$$K2_{bt} - K2_{bt-1} - \sum_z \sum_s F2_{zs} X2_{zsb} - T2_{zsb} = -Dem_{bt} \quad \forall b, z \in Z_b, s \in S_z, t > 1 \quad (7)$$

(Fuel flow-balance constraint for BLT groups $t > 1$)

$$K2_{bt} \geq L_b \quad \forall b, t = 24, 48, 72, 96, 120 \quad (8)$$

$$K1_{zt}, K2_{bt} \leq N \quad \forall z, b, t \quad (9)$$

$$K1_{zt}, K2_{bt} \leq \beta L_b \quad \forall z, b, t \quad (10)$$

$$DOS_z, DOS_b \geq 1000 \quad \forall z, b \quad (11)$$

$$I1_{ah0} = M1_{ah} \quad \forall a, h \quad (12)$$

$$I2_{zs0} = M2_{zs} \quad \forall z, s \quad (13)$$

$$X1_{ahzt} \geq 0 \text{ and integer} \quad \forall a, h, z, t \quad (14)$$

$$X2_{zsb} \geq 0 \text{ and integer} \quad \forall z, s, b, t \quad (15)$$

E. DESCRIPTION OF THE FORMULATION

The purpose of SBLOM is to determine if sea-based logistic support can satisfy the demands of the BLT groups over a specific time horizon and, if it can, minimize the “footprint” of the required fuel, on land, at the start of the operation. We use total initial inventory of fuel as a surrogate for footprint.

Besides minimizing the initial footprint (roughly), SBLOM also keeps subsequent footprints small by constraining maximum fuel levels to a multiple of the daily fuel requirement of the BLT. If the ARG is unable to properly sustain the BLT, either large initial inventories are required, or the model becomes infeasible.

The objective function minimizes initial gallons of fuel at all landing zones and BLT groups, plus a small artificial shipping cost associated with lift-asset movements. The artificial shipping cost α_t encourages just-in-time fuel deliveries: α_t is a decreasing

linear function in t which starts at 0.05 for $t=0$ and decreases to nearly 0 at the end of the time horizon. With this definition, it is better for the model to wait until the last possible moment to ship needed fuel.

Constraints 2 and 3 are the flow-balance equations for the lift sub-networks. They ensure that, for each time period, assets returning from round trips and inventory from the previous period balance with outbound assets and asset inventory going into the next period. There is no inventory of sea-based lift assets at the landing zones or land-based lift assets at the BLT groups because lift assets conduct round trips from their respective bases.

Constraints 4 and 5 are the flow-balance equations for fuel at the landing zones for all t . They allow land-based lift assets to depart only if there is fuel available for delivery. They also account for fuel consumed by the lift assets during each round trip. The fuel consumption rate of each land-based lift asset, G_s , when multiplied by $\Omega T 2_{zsb}$, estimates the amount of fuel consumed by a land-based lift asset making one round trip. Constraints 6 and 7 are analogous to constraints 4 and 5 but are combined flow-balance/demand constraints for the BLT groups.

Constraints 2-7 contain linking variables between the fuel and lift networks. They allow fuel flow only if sea-based lift assets are available at the amphibious ships and fuel and land-based lift assets are available at the landing zones. Constraints 8 require each BLT group to end each day with an amount of fuel that meets or exceeds their total daily fuel requirement.

Constraints 9-11 ensure that fuel inventory levels at the BLT groups and the landing zones are within prescribed bounds. Constraints 12-13 initialize the starting inventories of assets in the lift network.

F. RELATED RESEARCH

The optimization model proposed in this thesis, SBLOM, is similar to the SUMIT model (Glaser 1991) and the PaMM model (Aviles 1995). SUMIT is a mixed-integer programming model that generates optimal schedules for transporting sea mines. SUMIT uses interconnected, time-expanded mine-movement and transportation-asset networks. Mines can be moved only if the appropriate air, land or sea transportation assets are available. PaMM is an integer-programming model that develops deployment schedules for U.S. Army divisions. PaMM uses a ship lift network and an Army unit network to move Army units for two simultaneous multi-regional contingencies. The networks are interconnected through constraints that allow army units to move only when ships are available to move them.

SBLOM also consists of two interrelated network models, a fuel network model, and a lift network model. Nodes in the fuel network represent ships, landing zones, and BLT groups. SBLOM allows different equipment combinations within the landing zones and ships. The landing-zone and BLT-group nodes are expanded by time. In this fashion, each node represents a specific location and point in time, and arcs may connect nodes that represent two different points in time and/or locations.

III. COMPUTATIONAL RESULTS

To illustrate the usefulness of SBLOM, this chapter analyzes the feasibility of sea-based logistics for Class III supply under two OMFTS scenarios. These scenarios are constructed to address three issues: (1) How far can the ARG station itself offshore? (2) Can ARG sea-based lift assets and LZ land-based lift assets sustain the BLT? (3) What is the fuel footprint during combat operations?

A. FUEL DEMAND DATA

Fuel demand data is compiled from data files used by the MAGTF II model described in the Center for Naval Analyses Research Memorandum 95-144, *Project Culebra: Sea-Based Combat Service Support for Ship-to-Objective Maneuver* (Magwood 1995). The daily fuel requirements for a BLT, by unit, are displayed in Table 1. The fuel demand for a BLT group is simply the sum of demands for the group's constituent units.

BLT Unit	Daily Fuel Requirement (Gallons)
Rifle Company	100
AAAV Platoon	2040
Artillery Battery	15100
Combat Engineer Platoon	200
Tank Company	1500
LAR Platoon	1800

Table 1. Daily Fuel Requirements for BLT

B. LIFT NETWORK DATA

1. MV-22 Osprey

The MV-22 Osprey tiltrotor aircraft represents the future Marine Corps' medium-lift aircraft platform. The MV-22 is scheduled to be operational in 2006 and will replace

the CH-46 Sea Knight helicopter. The MV-22 possesses greater speed, range and payload than its predecessor. System performance data for the MV-22 are extracted from the Center for Naval Analyses study *Medium-Lift Replacement Cost and Operational Effectiveness Analysis* (Barfoot 1995). The MV-22 transports fuel in two 500-gallon external bladders; cruising speed with an external load is 150 knots.

The constant Tl_{ahz} for $h = \text{"MV-22"}$ represents the time required to transit, arrive and unload fuel at a landing zone. At the landing zone, the MV-22 takes a total of 6 minutes: 2 minutes to drop fuel bladders, 2 minutes to pick up empty fuel bladders, and 2 minutes to transition to cruising speed. The constant Rl_{ahz} for $h = \text{"MV-22"}$ represents the time required by the MV-22 to leave landing zone z , transit back to ship a where it refuels and reloads for another round trip. Refueling and reloading are assumed to take a total of one hour. All travel times, loading times and unloading times are rounded to the nearest hour to fit SBLOM's time-discretization of hours. Tl_{ahz} will roughly equal the transit time plus an additional six minutes. Rl_{ahz} will roughly equal transit return time plus one additional hour.

2. Landing Craft Air Cushion (LCAC)

The LCAC is a high-speed, over-the-beach landing craft capable of carrying heavy payloads at speeds in excess of 35 knots. Already operational, the LCAC can reach more than 70 percent of the world's coastline, giving the Marines a tremendous advantage over conventional landing craft. The LCAC transports fuel using the same 500-gallon bladders carried externally by the MV-22. The LCAC can carry up to 8000 gallons when fully loaded. For this thesis, it is assumed that an LCAC carries six 500-gallon bladders for a total of 3000 gallons of fuel in addition to other supplies.

The constant $T1_{ahz}$ for $h = \text{"LCAC"}$ equals transit time to the landing zone plus unloading time. LCAC transit speed is 35 knots. For the LCAC, loading and unloading take 80 minutes each, while refueling takes 15 minutes (Magwood 1995). $R1_{ahz}$ for $h = \text{"LCAC"}$ takes into account return transit time and time to dock, refuel and reload. $R1_{ahz}$ for an LCAC will roughly equal the return transit time plus 3 hours.

3. LVS and 5-TON

To move fuel from the landing zones to the BLT groups, the MK48/14 logistic vehicle system (LVS) and the M818 5-ton tractor are used. The LVS is a combination of the front-powered MK48 unit and any one of five rear body units. To transport fuel, the LVS utilizes the MK14 container platform configuration. The MK14 uses a half-size international standards container (ISO) platform that carries 2,700 gallons of fuel in three, 900-gallon containers called "SIXCONs." A SIXCON is a containerized module consisting of a tank and a specially designed shipping frame, which allows six of these tanks to fit in a full-size, ISO 8-foot by 20-foot container (Tradeways 1999). The M818 5-ton tractor is also a combination of two units with a 5,000-gallon semi-trailer attached to the rear of the tractor. Both the LVS and 5-ton tractor travel at twenty-five miles per hour. Fuel demand for the LVS is 17 gallons/hour and 14 gallons/hour for the M818 5-ton tractor.

The constant $T2_{zst}$ for $s = \text{"LVS"}$ and $s = \text{"5-ton"}$ is calculated by adding transit time to the BLT group and total fuel pump time at the BLT group. It is assumed that fuel is pumped out using a 100 gallons per minute (GPM) pump. (The Marine Corps has 600 GPM pumps, but the 100 GPM pumps are used for a conservative estimate.) $R2_{zsb}$ for the LVS and 5-ton is based on return transit time plus one additional hour to refuel and

reload each vehicle. The constant Ω represents twice the fraction of time each land-based lift asset moves and consumes fuel during a one-way transit. It is assumed for the LVS and 5-ton that they are moving 80% of the time in a one-way transit, so $\Omega = 2(.8) = 1.6$.

The remainder of this chapter provides detailed analysis of two OMFTS scenarios receiving sea-based logistic support. The first scenario involves a MEU(SOC) in a humanitarian mission while the second scenario has the MEU(SOC) conducting an amphibious raid. The ability of the ARG and the landing-zone support teams to sustain bulk fuel to the BLT is discussed for both scenarios.

C. FIRST SCENARIO, A HUMANITARIAN MISSION

The first scenario has the 11th MEU(SOC) deployed out of San Diego and embarked on Amphibious Squadron Three. The ARG consists of the USS Tarawa (LHA-1), USS Denver (LPD-9), and USS Mount Vernon (LSD-39). The MEU(SOC) is to assist in the disaster relief effort on the island of Guam. Since the ARG is the nearest naval force, it is to provide equipment, personnel, and security for a duration of five days until a United Nations coalition force arrives.

Due to the tremendous damage to Guam's pier landings, ships are unable to pull into port and must remain stationed offshore. The scenario has six BLT units divided into two groups and two landing-zone support teams established ashore. The ARG is providing sea-based logistic support at 50 nautical miles offshore in the baseline scenario.

BLT group 1, consisting of three rifle companies, an AAV platoon, and a combat engineer platoon, is located twenty miles from landing zone Eagle. BLT group 2, consisting of a tank company and a Light Armor Reconnaissance (LAR) platoon, is

located twenty miles from landing zone Hawk. As part of the sensitivity analysis, the ARG is stationed at three different distances, 50, 70 and 100 nautical miles from shore.

Figure 5 illustrates the scenario and Tables 2-7 list the input data for the model runs. Table 2 makes the assignments for ships to landing zones and landing zones to BLT groups with their respective distances from each other. Tables 3-5 list the input data for the sea-based lift assets. Table 6 lists the input data for the land-based lift assets at the landing zones. Table 7 provides the daily fuel requirement for the BLT groups.

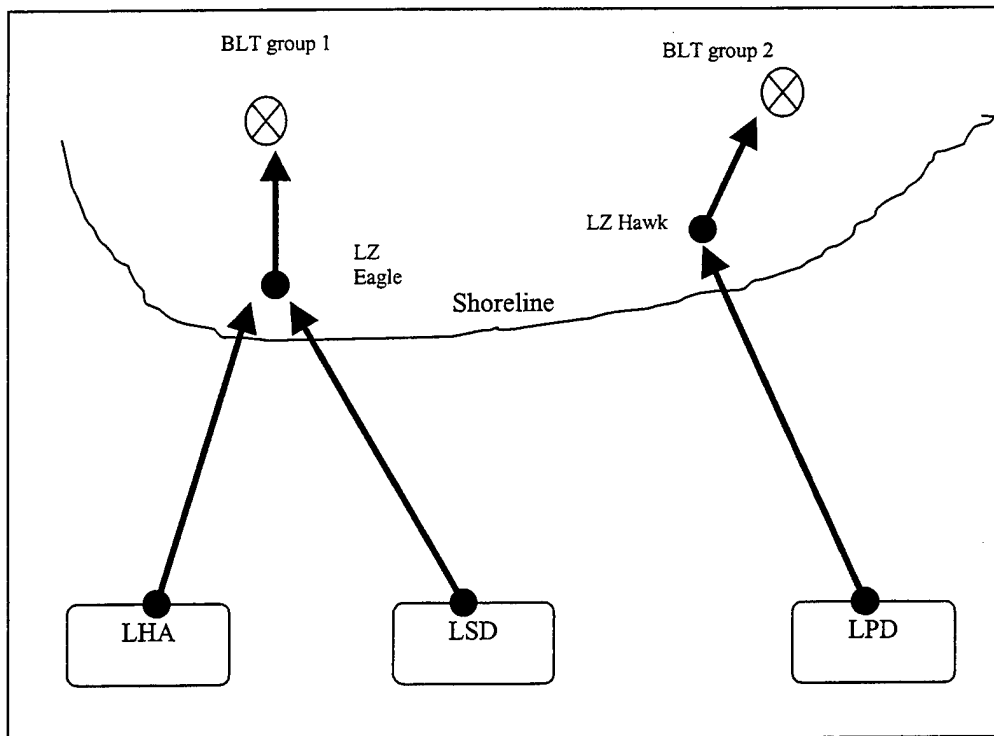

Figure 5. Scenario 1 Layout. BLT is conducting a humanitarian mission receiving fuel support from two landing zones. The ARG is unable to dock pierside and is stationed 50 to 100 nautical miles from shore.

SHIP	LANDING ZONE	LANDING ZONE INLAND DISTANCE	LZ DISTANCE TO BLT GROUP	BLT GROUP
LHA-1	Eagle	2 nm	20 miles	1
LPD-9	Hawk	2 nm	20 miles	2
LSD-39	Eagle	3 nm	20 miles	1

Table 2. Scenario 1 Ship and Landing Zone Assignments

Ship (a)	Asset (h)	$M1_{ah}$ (Initial Inventory)	$T1_{ahz}$ (hours)	$R1_{ahz}$ (hours)	$F1_{ah}$ (gals)
LHA-1	MV-22	8	1	1	1000
	LCACs	1	3	4	3000
LPD-9	MV-22	4	1	1	1000
	LCACs	2	3	4	3000
LSD-39	MV-22	0	1	1	1000
	LCACs	4	3	5	3000

Table 3. Scenario 1 Input Data for 50 nm

Ship (a)	Asset (h)	$M1_{ah}$ (Initial Inventory)	$T1_{ahz}$ (hours)	$R1_{ahz}$ (hours)	$F1_{ah}$ (gals)
LHA-1	MV-22	8	1	2	1000
	LCACs	1	3	5	3000
LPD-9	MV-22	4	1	2	1000
	LCACs	2	3	5	3000
LSD-39	MV-22	0	1	2	1000
	LCACs	4	3	5	3000

Table 4. Scenario 1 Input Data for 70 nm

Ship (a)	Asset (h)	$M1_{ah}$ (Initial Inventory)	$T1_{ahz}$ (hours)	$R1_{ahz}$ (hours)	$F1_{ah}$ (gals)
LHA-1	MV-22	8	1	2	1000
	LCACs	1	4	6	3000
LPD-9	MV-22	4	1	2	1000
	LCACs	2	4	6	3000
LSD-39	MV-22	0	1	2	1000
	LCACs	4	4	6	3000

Table 5. Scenario 1 Input Data for 100 nm

Landing Zone (z)	Transport Vehicle (s)	$M2_{ah}$ (Initial Inventory)	$T2_{zsb}$ (hours)	$R2_{zsb}$ (hours)	$F2_{zs}$ (gals)	G_s (gals/hr)
Eagle	LVS	3	1	2	2700	17
	5TON	3	2	2	5000	14
Hawk	LVS	3	1	2	2700	17
	5TON	3	2	2	5000	14

Table 6. Scenario 1 Input Data for Landing Zones

BLT Groups	BLT Units	Fuel Demand (Gallons/Day)
1	1,2,4	2540
2	5,6	3300

Table 7. Scenario 1 BLT Input Data

D. RESULTS OF FIRST SCENARIO

SBLM is written using the General Algebraic Modeling System (GAMS) (Brooke *et al.* 1992) and solved using IBM's Optimization Subroutine Library (OSL) (IBM 1991). A copy of the GAMS formulation can be obtained from the author.

SBLM is run on a Micron Pentium 266 MHz computer. Model and solution statistics for the first scenario test runs are displayed in Table 8. "Solution times" represent the total time for generating and solving each model to a "relative optimality tolerance" of 0.01 (i.e., 1%) (Brooke *et al.* 1992, p. 268).

As the ARG is stationed farther from shore, solution times increase. Although model size does not change with distance from shore, round-trip times for ship assets increase. Apparently, this makes scheduling of lift assets more difficult and solution times longer.

Model Run	Solution Time (Seconds)	Number of Variables	Number of Constraints	Number of Time Periods
50 nm	655	4085	2915	120
70 nm	1333	4085	2915	120
100 nm	2154	4085	2915	120

Table 8. Scenario 1 Model and Solution Statistics

The figures in Appendix A show the fuel levels for the LZs and BLT groups during each test run. The horizontal axis on each graph represents the timeline for the scenario and the vertical axis represents the fuel inventory in gallons. For the BLT graphs, the dashed line represents the daily fuel requirement as shown in Figure 6. At the end of each day (0000 hours) the fuel level must be above the daily fuel requirement, but may dip below at other times of the day. This constraint helps to ensure that fuel deliveries are made on a regular basis and that big swings in inventory levels are avoided.

However, there is no explicit attempt to minimize peak inventories; that issue is left for future investigation.

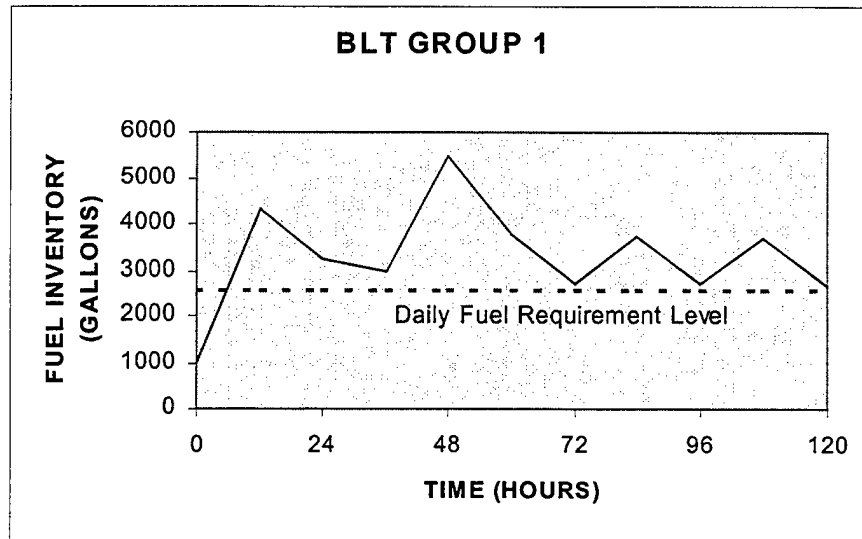

Figure 6. Scenario 1 Fuel Levels for BLT Group 1 (50 nm)

Note that the minimum initial fuel requirements determined by the model are significantly lower than the daily fuel requirement levels, which are input data. This is true across most of the scenario variants and indicates that, for the most part, fuel transport capabilities are more than sufficient to meet needs. So, even if initial inventories were empty, available lift assets would be able to make up the shortfall in a matter of a few hours.

In Figure 6, fuel levels remain above the daily fuel requirement during the entire planning horizon, which indicates that BLT group 1's fuel needs are met successfully from the ARG and landing zones. As the ARG's stand-off distance is increased to 70 nm and then to 100 nm (see Figures 17 and 21 in Appendix A), the BLT group 1's fuel levels still remain above the daily requirement, but there are steeper drops in those levels.

Another effect that occurs as the ARG is stationed farther from shore is an increase in the number of MV-22 sorties. Table 9 lists the number of sorties for each distance from shore. As the ARG distances itself from the shore, the MV-22 is utilized more and the LCAC less. This result is expected since the MV-22 travels at a much higher speed than the LCAC. At the landing zones, a trend appears with regard to the utilization of the 5-ton tractor and the LVS. The 5-ton tractor's sorties increase while the LVS's decreases. Although the LVS has a shorter round trip, the 5-ton tractor can transport almost twice as much fuel.

	MV-22 Sorties	LCAC	LVS	5TON
50 nm	14	10	7	4
70 nm	16	10	3	6
100 nm	17	8	2	6

Table 9. Scenario 1 Sorties

SBLOM's main objective is to minimize the initial inventory of fuel required at the LZs (DOS_z) and BLT groups (DOS_b); other constituents of the objective function are small. Table 10 summarizes the results for the three model runs. As the distance of the ARG increases from 50 nm, 70 nm, and 100 nm, the overall objective function increases indicating that higher initial fuel levels are required to sustain the operation.

Location	50 nm	70 nm	100 nm
LZ Eagle	1050	1000	1050
LZ Hawk	2050	2050	2050
BLT Group One	1000	1300	1400
BLT Group Two	1000	1000	1000
Objective Value	5897	6692	6928

Table 10. Scenario 1 Initial Fuel Supply (Gallons) and Objective Values

E. SECOND SCENARIO, AN AMPHIBIOUS RAID

The second scenario simulates the 11th MEU(SOC) conducting an amphibious raid. The BLT has established its inland positions and has been tasked to hold its current position for five days. For this scenario, the BLT divides into three groups and is supported by three landing-zone support teams established ashore. BLT group 1 contains three rifle companies and one AAVV platoon. BLT group 2 consists of an artillery battery and a combat engineer platoon. BLT group 3 consists of a tank company and a LAR platoon. Figure 7 illustrates the scenario and Tables 11-16 list the input data.

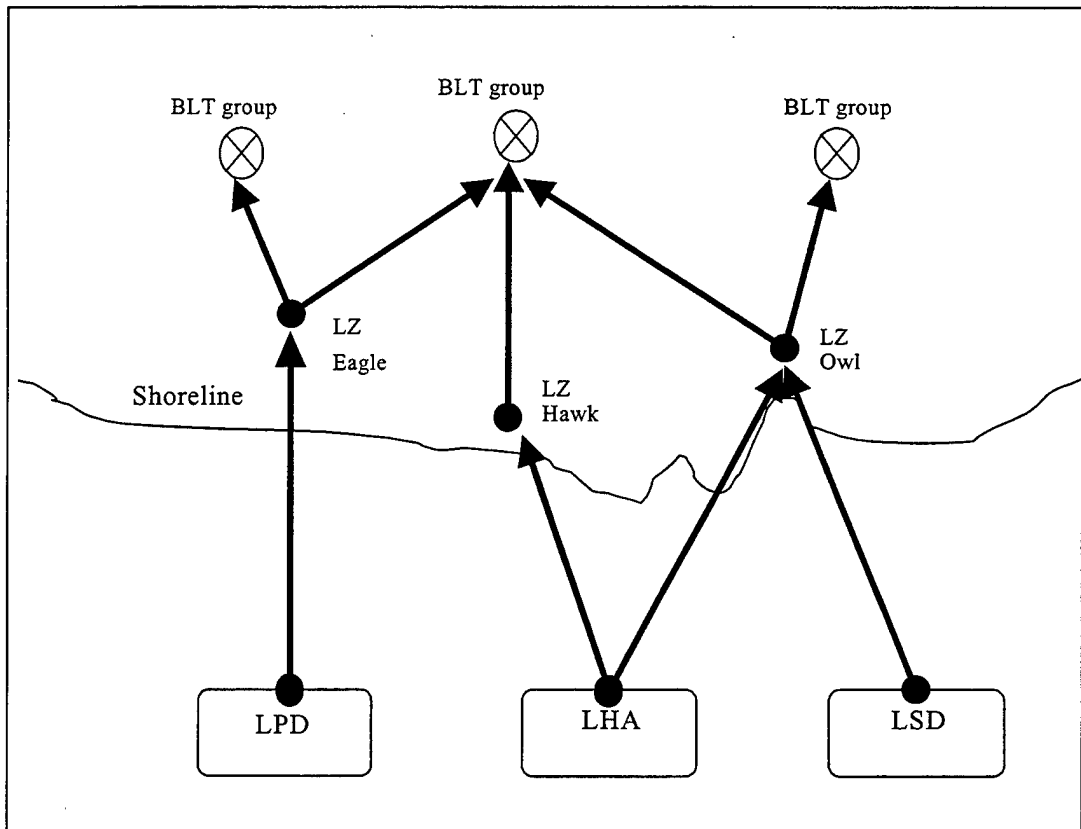

Figure 7. Scenario 2 Layout. The BLT, divided into three conducting an amphibious raid while receiving fuel support from landing zones.

Compared to the first scenario, this scenario is of higher intensity and complexity. Due to the large daily demand at BLT group 2, all three landing zones supply fuel to this group. The LHA of the ARG provides fuel to landing zones Hawk and Eagle due to their higher inventory of MV-22s. For this scenario, the number of MV-22s, LVS vehicles and 5-ton tractors is increased to help meet the increased overall fuel demand. Again, we analyze the scenario with ARG stand-off distances of 50, 70 and 100 nautical miles.

SHIP	LANDING ZONE	LANDING ZONE INLAND DISTANCE	LZ DISTANCE TO BLT GROUP	BLT GROUP
LHA-1	Hawk	2 nm	15 miles	2
	Owl	3 nm	25 miles	3
LPD-9	Eagle	3 nm	25 miles	1
LSD-39	Owl	3 nm	25 miles	3

Table 11. Scenario 2 Ship and Landing Zone Assignments

Ship (a)	Asset (h)	$M1_{ah}$ (Initial Inventory)	$T1_{ahz}$ (hours)	$R1_{ahz}$ (hours)	$F1_{ah}$ (gals)
LHA-1	MV-22	12	1	1	1000
	LCACs	1	2	4	3000
LPD-9	MV-22	4	1	1	1000
	LCACs	2	2	4	3000
LSD-39	MV-22	0	1	1	1000
	LCACs	4	2	4	3000

Table 12. Scenario 2 Input Data for 50 nm

Ship (a)	Asset (h)	$M1_{ah}$ (Initial Inventory)	$T1_{ahz}$ (hours)	$R1_{ahz}$ (hours)	$F1_{ah}$ (gals)
LHA-1	MV-22	12	1	1	1000
	LCACs	1	3	5	3000
LPD-9	MV-22	2	1	1	1000
	LCACs	2	3	5	3000
LSD-39	MV-22	0	1	1	1000
	LCACs	4	3	5	3000

Table 13. Scenario 2 Input Data for 750 nm

Ship (a)	Asset (h)	$M1_{ah}$ (Initial Inventory)	$T1_{ahz}$ (hours)	$R1_{ahz}$ (hours)	$F1_{ah}$ (gals)
LHA-1	MV-22	12	1	2	1000
	LCACs	1	3	6	3000
LPD-9	MV-22	2	1	2	1000
	LCACs	2	3	6	3000
LSD-39	MV-22	0	1	2	1000
	LCACs	4	3	6	3000

Table 14. Scenario 2 Input Data for 100 nm

Landing Zone (z)	Transport Vehicle (s)	$M2_{ah}$ (Initial Inventory)	$T2_{zsb}$ (hours)	Return Speed (miles/hr)	$R2_{zsb}$ (hours)	$F2_{zs}$ (gals)	G_s (gals/hr)
Eagle	LVS	5	1	25	3	2700	17
	5TON	5	2	25	3	5000	14
Hawk	LVS	5	1	25	3	2700	17
	5TON	5	2	25	3	5000	14
Owl	LVS	5	1	25	3	2700	17
	5TON	5	2	25	3	5000	14

Table 15. Scenario 2 Input Data for Landing Zones

BLT Groups	BLT Units	Fuel Demand (Gallons/ Day)
1	1,2	2340
2	3,4	15300
3	5,6	3300

Table 16. Scenario 2 BLT Input Data

F. RESULTS OF SECOND SCENARIO

Table 17 displays model and solution statistics for the second scenario. Solution times increase significantly over the first scenario.

Stand-off Distance	Solution Time (Seconds)	Number of Variables	Number of Constraints	Number of Time Periods
50 nm	1601	6487	3643	120
70 nm	2218	6487	3643	120
100 nm	4093	6487	3643	120

Table 17. Scenario 2 Model and Solution Statistics

The fuel levels for the LZs and BLT groups for each model run are included in Appendix B. In general, the graphs of this scenario exhibit more of a “saw-toothed”

behavior. Figure 8 is a typical graph showing this behavior. As landing zones and BLT groups receive fuel, the increased fuel demand causes the inventory level to drop rapidly.

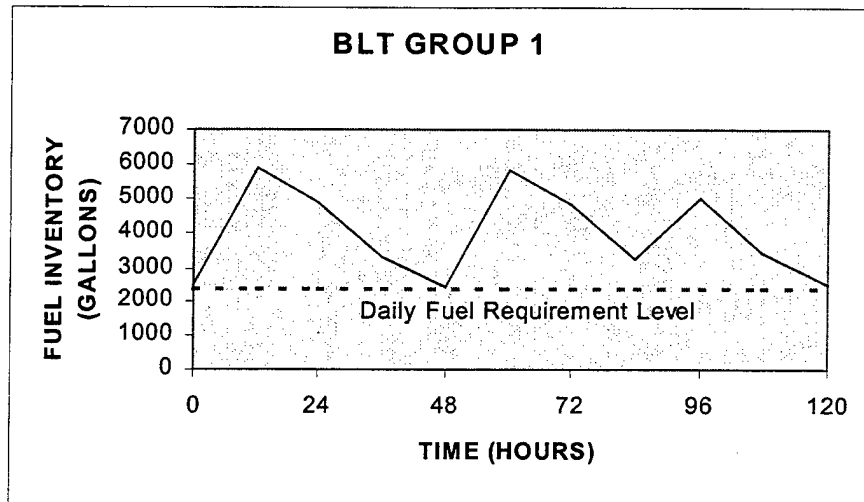

Figure 8. Scenario 2 Fuel Levels for BLT 1 (50 nm)

When compared to the first scenario, this scenario has more lift and transportation assets available on the ships and at the landing zones. This increase is necessary to ensure feasibility for the three stand-off distances. In addition, the minimum inventory levels for fuel at the BLT units are, on average, higher than those of the first scenario. This can be attributed to the higher fuel demand of the BLT groups in the second scenario.

The total number of sorties in the second scenario increases significantly over the first. For each model run, the number of sorties for each lift asset is almost four times as many as seen in the first scenario. A breakdown of sorties for each asset type is given in Table 18.

Stand-off	MV-22 Sorties	LCAC	LVS	5TON
50 nm	99	14	6	23
70 nm	102	15	4	26
100 nm	111	14	1	26

Table 18. Scenario 2 Sorties

As with the first scenario, the MV-22 continues to be the primary fuel transport platform as the ARG moves farther from the landing zones. The LCAC does contribute more in the second scenario, but its cruising speed of 35 knots limits its opportunities as distance to the shore increases. At the landing zones, the 5-ton tractor is utilized much more frequently in the second scenario because of higher fuel demand. Another effect of the higher fuel demand occurs in the solution for initial fuel required at the landing zones (DOS_z) and BLT groups (DOS_b). For all model runs, the initial fuel required almost doubles over the first scenario's requirements as seen in Table 19.

Location	Stand-off Distance		
	50 nm	70 nm	100 nm
LZ Eagle	2050	1000	2050
LZ Hawk	1652	1476	4703
LZ Owl	1050	1373	3050
BLT Group One	1000	2435	1000
BLT Group Two	1000	1000	1000
BLT Group Three	1000	1000	1000
Objective Value	10601	11067	15617

Table 19. Scenario 2 Initial Fuel Supply (Gallons)

One observation about the solutions for DOS_z and DOS_b is that SBLOM does not favor one landing zone or BLT group over another. For example, landing zone Eagle is assigned 2050 gallons and landing zone Hawk is assigned 1652 gallons when the ARG is 50 nm away. At 70 nm, landing zone Eagle is assigned 1000 gallons and landing zone Hawk is assigned 1476 gallons. As long as total initial fuel is minimized, SBLOM does

not care where that fuel is located. If desired, it should not be too difficult to modify the model so that initial fuel is evenly divided among the landing zones and/or BLT groups.

G. ADDITIONAL MODEL RUNS

Since SBLOM achieves solutions in both scenarios, more runs are performed here for the following reasons: (1) to identify any limitations of SBLOM and OMFTS, (2) to explore effects of different asset configurations at the landing zones and ships, (3) to demonstrate how SBLOM can be tailored to evaluate different scenarios, and (4) to explore limitations of the solver.

For the first test, the ARG's distance from shore is increased to 200 nautical miles in both scenarios. Although the Navy and Marine Corps would normally operate at a stand-off distance of 100 nautical miles or less, stationing the ARG 200 nautical miles offshore is not unrealistic. For both missions, SBLOM is able to achieve a solution (although run times increase from 4093 seconds to 5814 seconds in the second scenario). Even at 200 nm, the OMFTS concept appears to work. However, this distance places a heavy reliance on the MV-22 whose number of sorties increases significantly in both scenarios. The LCAC is rarely used due to its long transit and return times.

Next, fuel loads are increased on both the MV-22 and LCAC. When the LCAC's fuel load is increased to 5000 gallons and the MV-22's fuel load is increased to 2000 gallons, SBLOM reaches integer solutions more quickly in both scenarios. Next, the Scenario 1 is run with no upper bound restrictions on the maximum fuel inventory levels for the BLT groups or landing zones. SBLOM does solve this problem, but the solution creates large peak fuel inventories at the landing zones and BLT groups, equating to unacceptably large fuel footprints. These results illustrate the flexibility of SBLOM for

testing doctrine: It is a simple matter to modify standard fuel loads and experiment with different maximum fuel inventory levels.

Next, the issue of losing a lift asset is examined. For this part of the analysis, the Scenario 1 is used and the fuel levels of BLT group 2 are investigated. Since BLT group 2 receives fuel from landing zone Hawk, the number of MV-22s and LCACs on the LPD that supply this landing zone are first decreased by one asset each and then by two. The fuel levels of BLT group 2 are displayed in Figure 9 with the baseline case and the two cases with attrition.

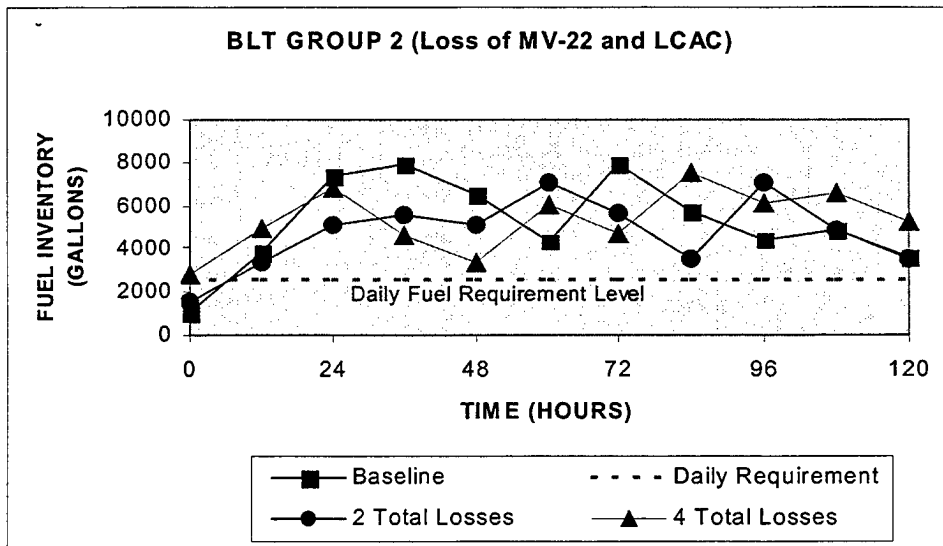

Figure 9. Loss of MV-22s and LCACs in Scenario 1 (50 nm)

The initial fuel supply for BLT group 1 increases as the LPD loses sea-based lift assets. For the baseline case, initial fuel supply is 1000 gallons, which rises to 1500 gallons for the two total losses and then 2750 gallons for the four total losses. SBLOM is able to maintain the fuel levels above the requirement level with these losses, but does so with a higher initial fuel supply.

Because the loss of land-based lift assets at the landing zones is also possible, this

situation is explored next. Scenario 1 is repeated but with the number of land-based lift assets at landing zone Hawk reduced. Figure 10 displays the fuel levels for the baseline case and two additional model runs, one with a single loss per land-based lift-asset type (two total) and the other with two losses per land-based lift asset type (four total). Initial fuel supply starts at 1000 gallons for the baseline, then increases to 2000 gallons for the case of two total losses, and finally increases to 3500 gallons for the case of four total losses. The results indicate that losses at the landing zones have a larger effect on the initial fuel requirements than losses onboard the ARG.

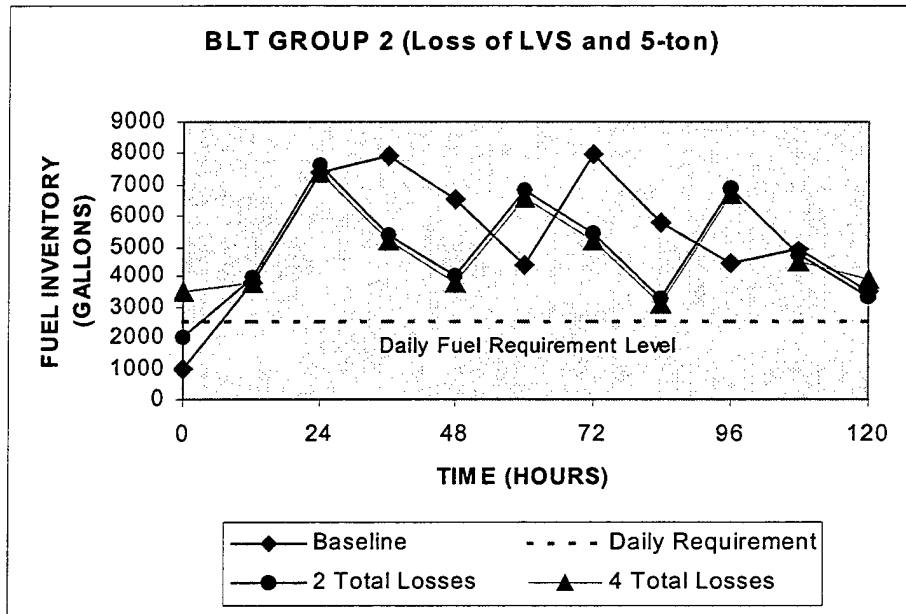

Figure 10. Loss of LVSs and 5-tons in Scenario 1 (50 nm)

IV. CONCLUSIONS

A. OVERVIEW

This thesis has developed the Sea-Based Logistic Model (SBLOM), to analyze the feasibility of sea-based logistics to support the combat fuel requirements of a Marine Expeditionary Unit (Special Operations Capable) (MEU(SOC)). The analysis is based on current and projected capabilities of Marine Corps lift assets and covers two baseline scenarios differing in fuel demand. The scenarios simulate hypothetical situations in an Operational Maneuver From the Sea (OMFTS) environment where combat forces receive replenishment through a short chain of sea-based and land-based assets. SBLOM achieves near-optimal solutions for both scenarios tested.

In OMFTS, sea-based lift assets from the amphibious readiness group (ARG) transport fuel to the landing zones and land-based lift assets transport fuel from the landing zones to the Battalion Landing Team (BLT). In SBLOM, two linked networks, a fuel network and a lift network represent this transportation of fuel from the ARG to the to the landing zones and on to the forward-deployed BLT groups.

The basic objective of SBLOM is to determine the minimum initial fuel requirements at the landing zones and BLT groups (groups of units) that allow sea-based logistics to sustain operations over a period of several days. SBLOM also provides a fuel-delivery schedule for the lift assets based on the ships of the ARG and based at the landing zones. In doing so, the abilities of these lift assets to conduct sea-based logistics in an OMFTS setting are assessed.

The scenarios developed to test SBLOM have a MEU(SOC) involved in a humanitarian mission and an amphibious raid. The level of fuel demand increases

significantly from the first scenario to the second scenario. In both scenarios, the use of sea-based logistics is able to successfully meet the daily fuel requirements of the MEU(SOC) and also maintain sufficient fuel levels throughout the mission's duration.

Additional runs are also conducted to identify limitations of SBLOM. When the ARG is placed 200 nm from shore, SBLOM reaches a solution in both scenarios but computation time roughly doubles. When the fuel load of the LCAC and MV-22 is increased, solution times do not change much. Other areas of analysis include loss of lift assets from the ships and land-based lift assets at the landing zones. Results indicate the losses at the landing zones are more critical than losses on the ships.

B. SUGGESTED MODEL IMPROVEMENTS

The results from both scenarios and the additional model runs illustrate the flexibility of SBLOM. The model should be further enhanced to provide understanding into other aspects of OMFTS. Most importantly, the model should be expanded to allow for other classes of supply to be transported. The inclusion of multiple commodities could add further insight into the issue of the logistic footprint.

Developing a stochastic-programming model of sea-based logistics to investigate effects of weather, attrition, etc., could be useful; SBLOM may provide a template for building such a model. Running SBLOM in more scenarios based on the eighteen missions a MEU(SOC) is qualified to accomplish could also prove beneficial. Insight may be gained as to which lift assets lend the most flexibility to changes in mission requirements. Lastly, SBLOM should be converted into an elastic model that allows

demand to go unsatisfied at a penalty. Future analyses using an elastic model might better pinpoint why daily fuel requirements cannot be met for certain scenarios.

LIST OF REFERENCES

- Aviles, S. M., "Scheduling Army Deployments to Two Nearly Simultaneous Major Regional Conflicts," M.S. Thesis in Operations Research, Naval Postgraduate School, Monterey, CA 93943, September 1995.
- Bancroft, Bruce K., "Sea Based Logistics in Operational Maneuver From the Sea," Technical Report, Naval War College, June 14, 1996.
- Barfoot, C.B., "Medium Lift Replacement (MLR) Cost and Operational Effectiveness Analysis – Phase I, Volume II," Center for Naval Analyses Report 208, January 1995.
- Brooke, A., Kendrick, D., and Meeraus, A., *GAMS, A Users Guide*, GAMS Development Corporation, 1996.
- Dalton, John H., "Forward . . . From the Sea," Navy and Marine Corps White Paper, November, 1994.
- Glaser, T. L., "A Single-Commodity Mine Transshipment Problem," M.S. Thesis in Operations Research, Naval Postgraduate School, Monterey, CA 93943, September 1991.
- IBM, *OSL: Optimization Subroutine Library*, Guide and Reference, IBM Corporation, Kingston, NY, 1991.
- Ivancovich, John S., "Supporting Amphibious Assault from a Sea Base," Center for Naval Analyses Research Memorandum 91-6, April 1991.
- Krulak, Charles, C., "Operational Maneuver From the Sea: A Concept for the Projection of Naval Power Ashore," Marine Corps Concept Paper, June 1996.
- Magwood, Janet R., "Project Culebra: Sea-Based Combat Service Support for Ship-to-Objective Maneuver (Supply and Transportation Analysis)," Center for Naval Analyses Research Memorandum 95-144, September 1995.
- O'Keefe, Sean, ". . . From the Sea: Preparing the Naval Service for the 21st Century," Navy and Marine Corps White Paper, September 1992.
- Skipper, Charles, "Can We Fuel OMFTS?" *Marine Corps Gazette*, pp. 47-49, January 1997.
- Tradeways, ltd., "SIXCON Fuel and Water Storage & Dispensing Systems," <<http://www.nbcindustrygroup.com/handbook/collprot/tradeway4.jpg>> (accessed 22 March 1999).

United States Marine Corps, "Marine Expeditionary Units (Special Operations Capable)," 3 November 1997, <<http://www.usmc.mil/meus/meu.nsf>> (accessed 12 March 1998).

Van Riper, Paul K., "Surprising the Enemy," *Surface Warfare*, pp. 19-23, January 1998.

APPENDIX A

FIRST SCENARIO FUEL LEVELS

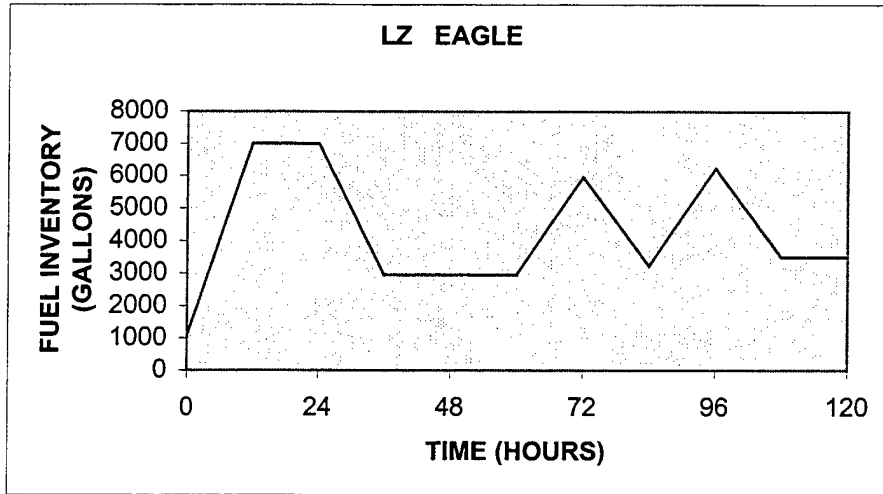

Figure 11. Landing Zone Eagle Fuel Inventory Levels
(Scenario 1, 50 nm)

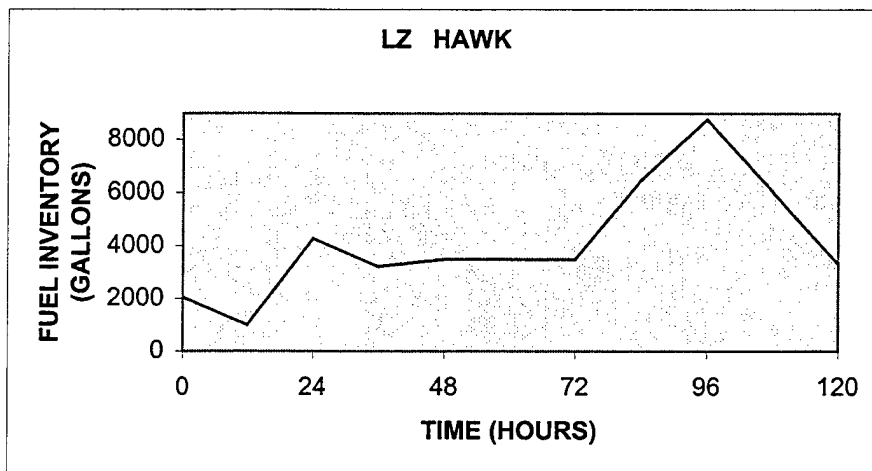
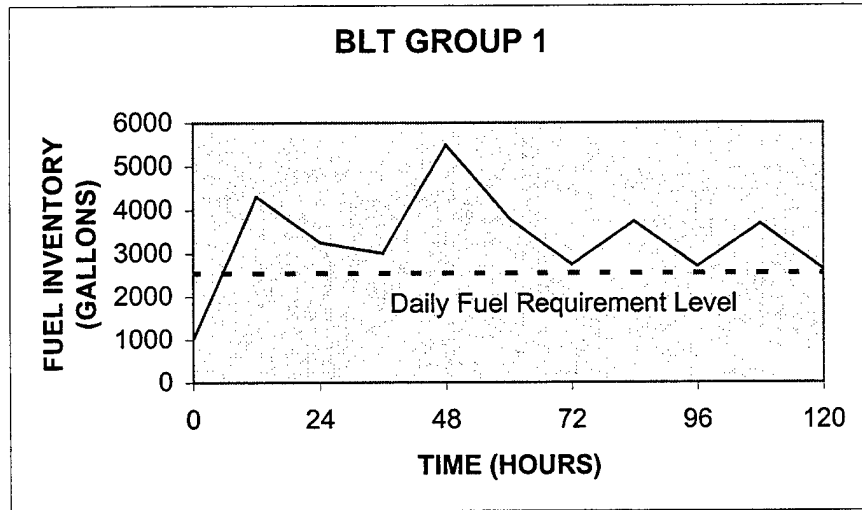
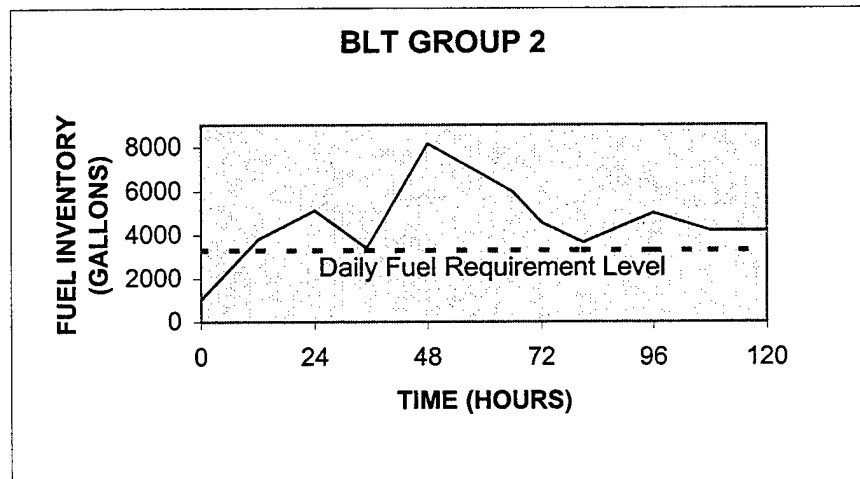

Figure 12. Landing Zone Hawk Fuel Inventory Levels
(Scenario 1, 50 nm)



**Figure 13. BLT Group 1 Fuel Inventory Levels
(Scenario 1, 50 nm)**



**Figure 14. BLT Group 2 Fuel Inventory Levels
(Scenario 1, 50 nm)**

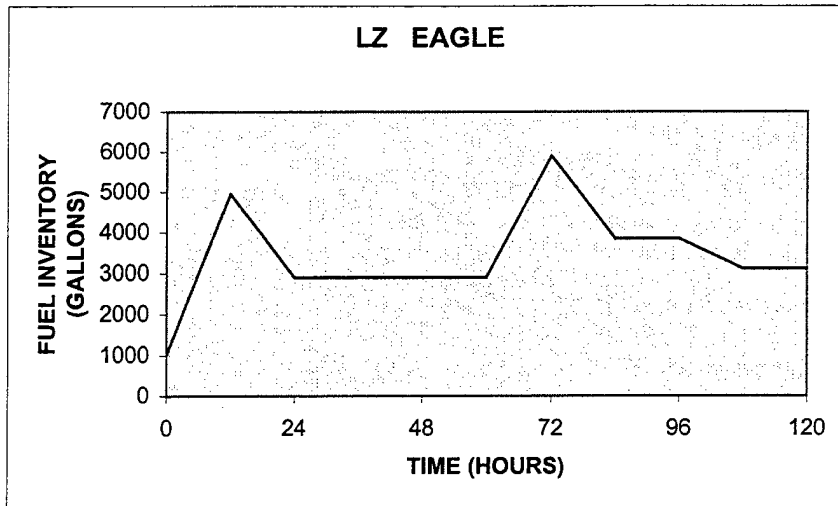

Figure 15. Landing Zone Eagle Fuel Inventory Levels (Scenario 2, 70 nm)

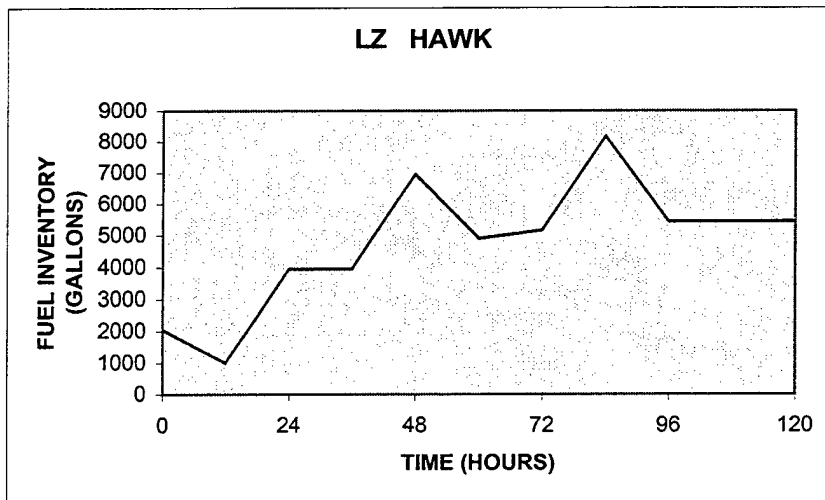
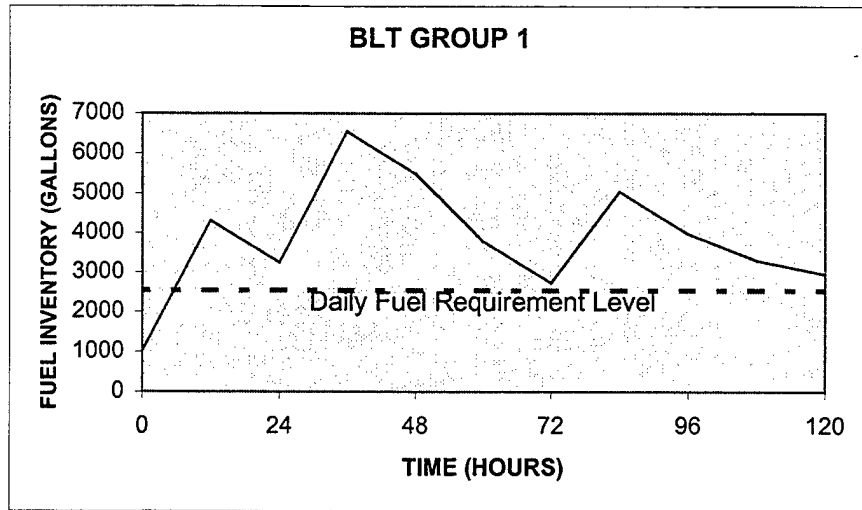
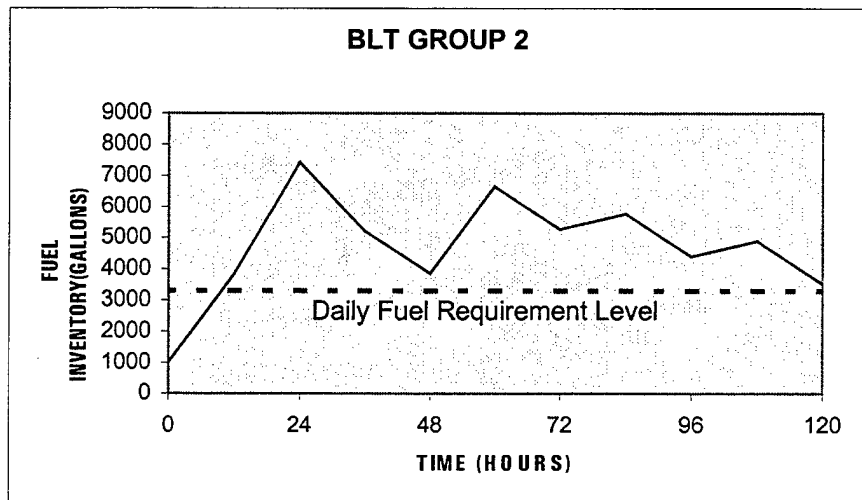

Figure 16. Landing Zone Hawk Fuel Inventory Levels (Scenario 1, 70 nm)



**Figure 17. BLT Group 1 Fuel Inventory Levels
(Scenario 2, 70 nm)**



**Figure 18. BLT Group 2 Fuel Inventory Levels
(Scenario 1, 70 nm)**

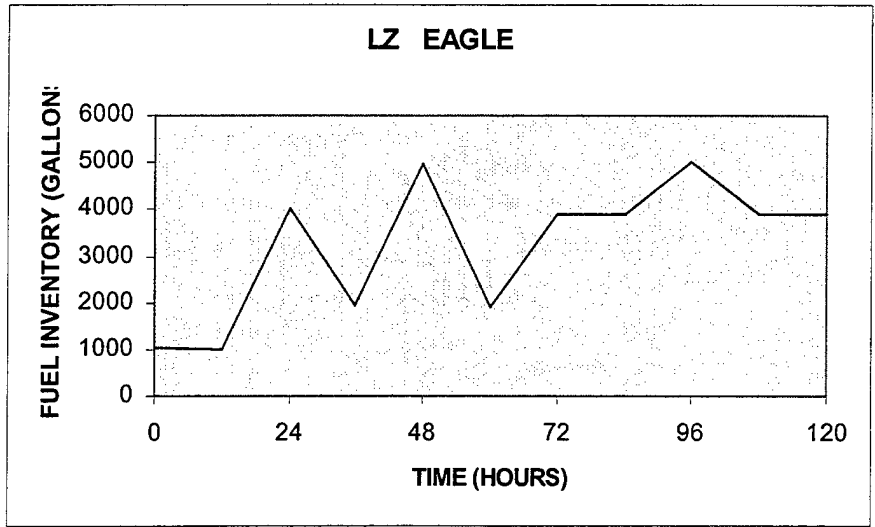

Figure 19. Landing Zone Eagle Fuel Inventory Levels (Scenario 1, 100 nm)

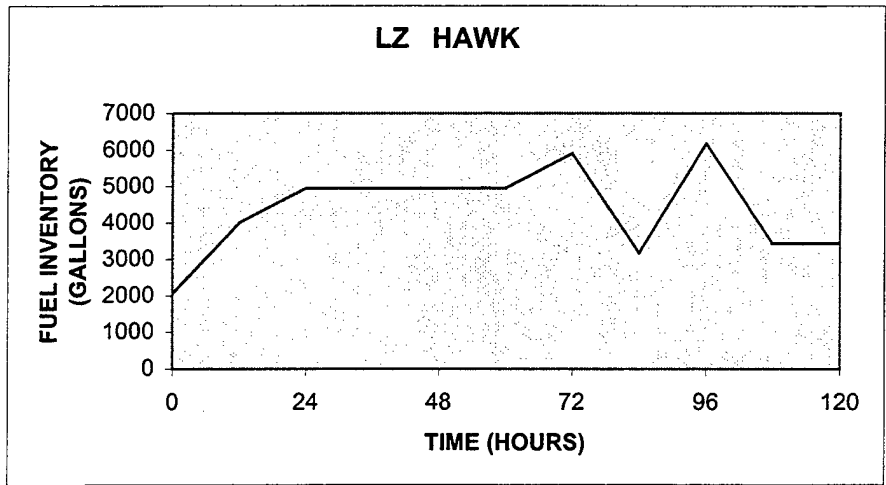

Figure 20. Landing Zone Hawk Fuel Inventory Levels (Scenario 1, 100 nm)

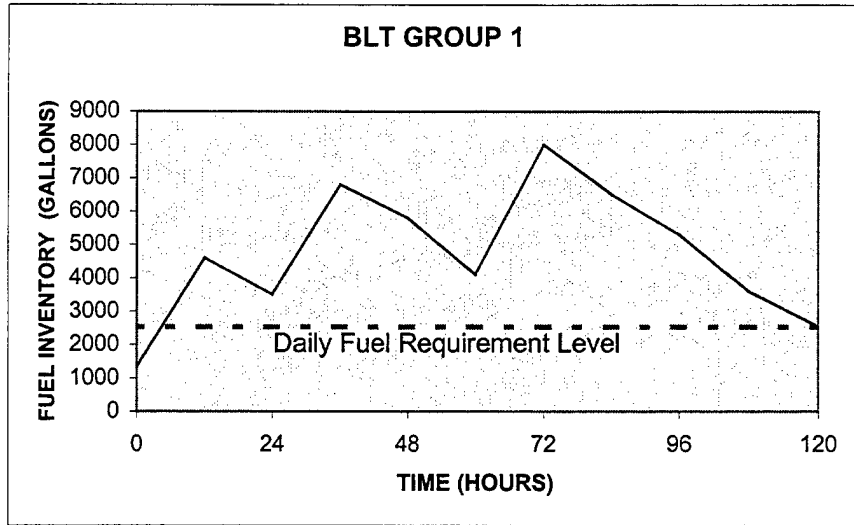

Figure 21. BLT Group 1 Fuel Inventory Levels (Scenario 1, 100 nm)

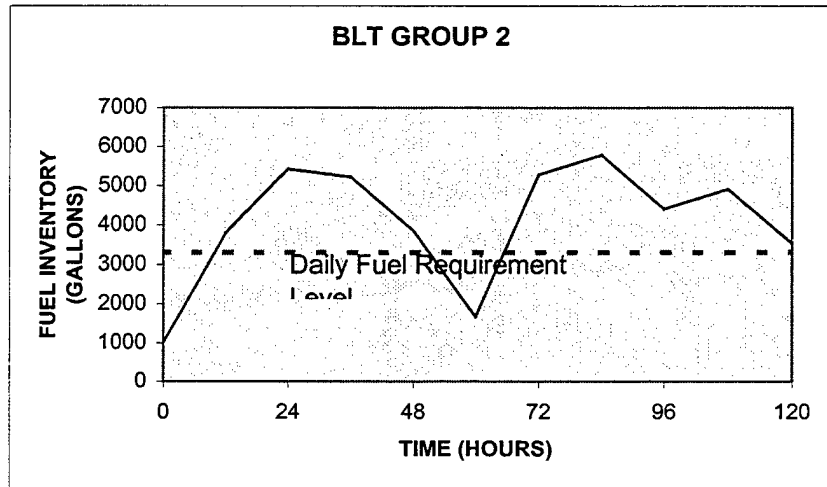

Figure 22. BLT Group 2 Fuel Inventory Levels (Scenario 1, 100 nm)

APPENDIX B

SECOND SCENARIO FUEL LEVELS

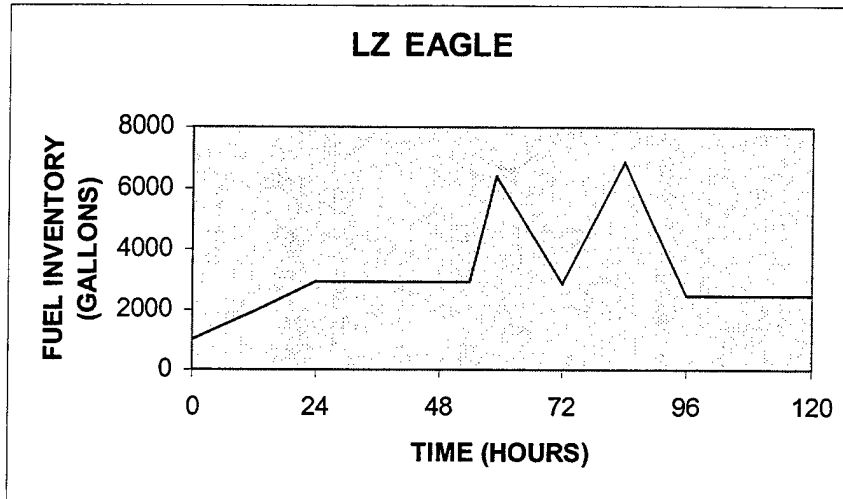

Figure 23. Landing Zone Eagle Fuel Inventory Levels (Scenario 2, 50 nm)

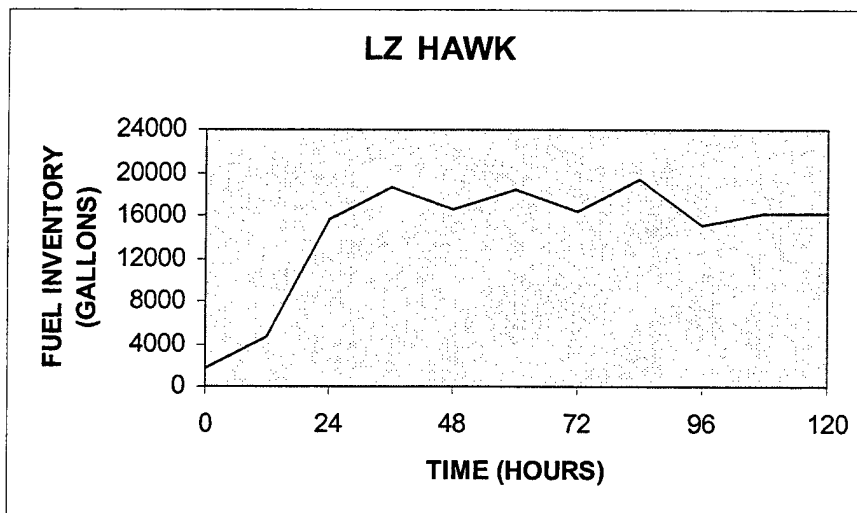

Figure 24. Landing Zone Hawk Fuel Inventory Levels (Scenario 2, 50 nm)

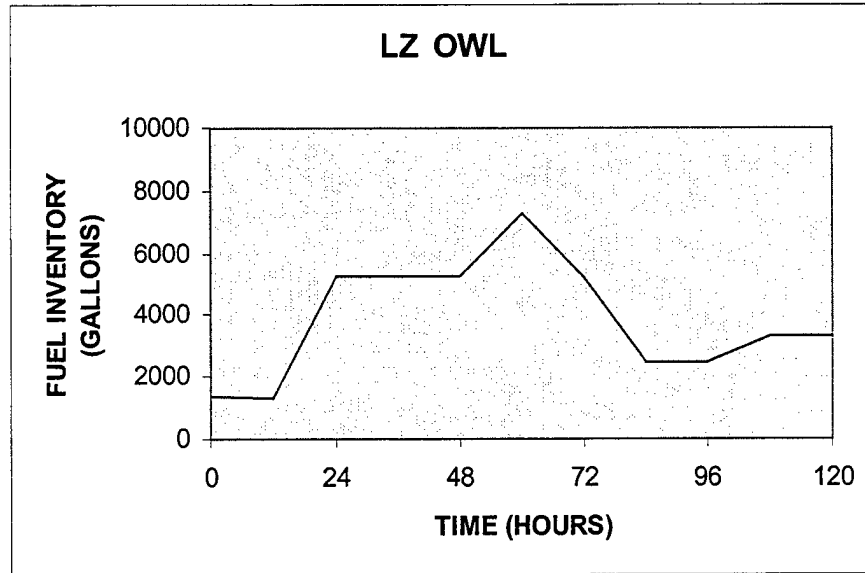

Figure 25. Landing Zone Owl Fuel Inventory Levels (Scenario 2, 50 nm)

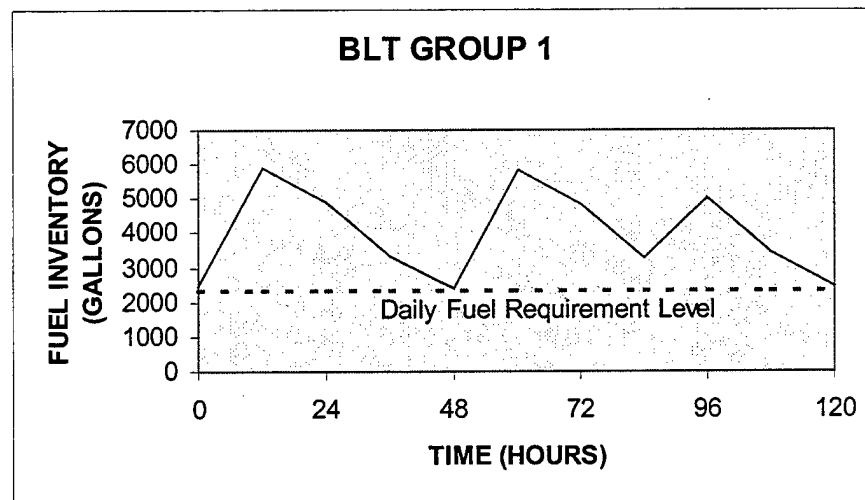

Figure 26. BLT Group 1 Fuel Inventory Levels (Scenario 2, 50 nm)

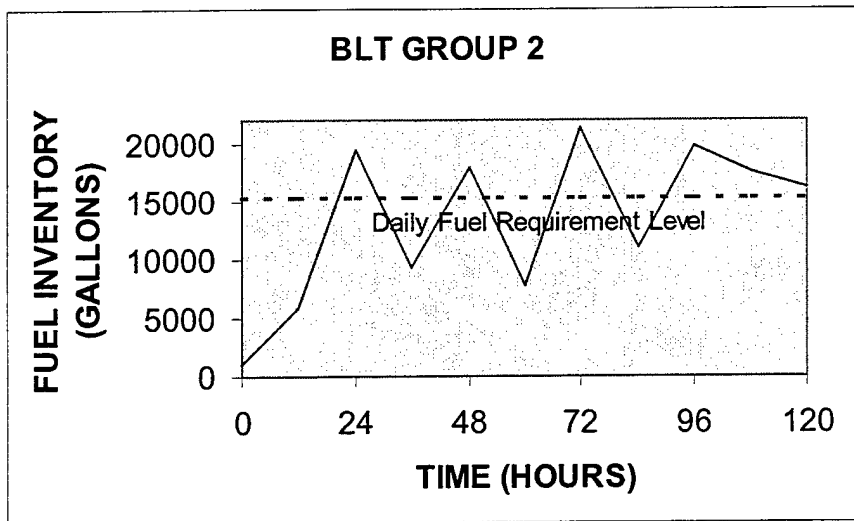

Figure 27. BLT Group 2 Fuel Inventory Levels (Scenario 2, 50 nm)

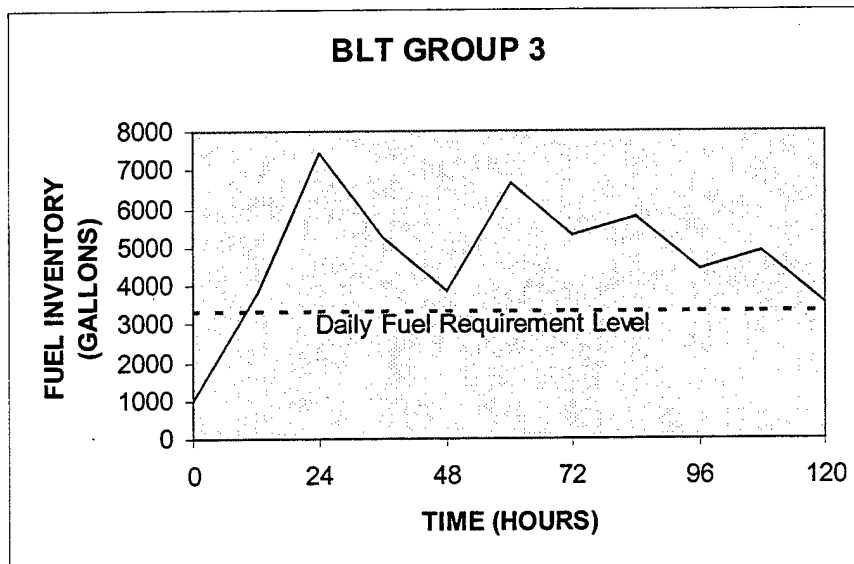
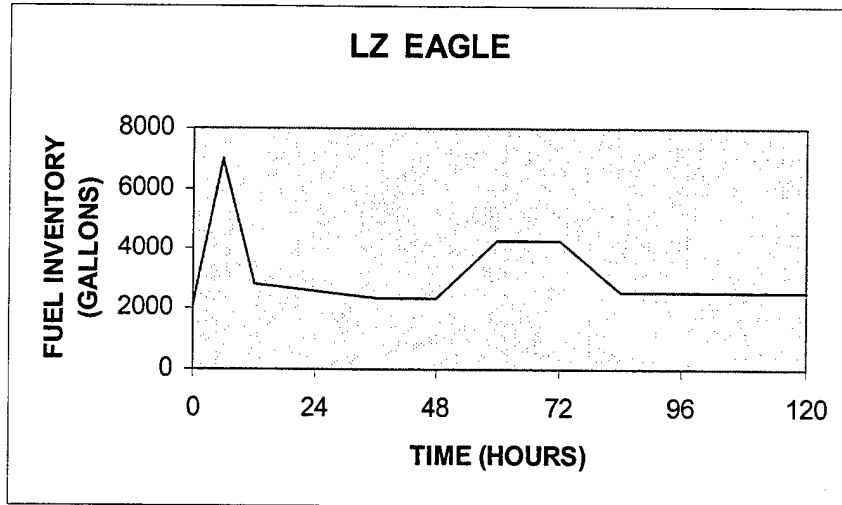
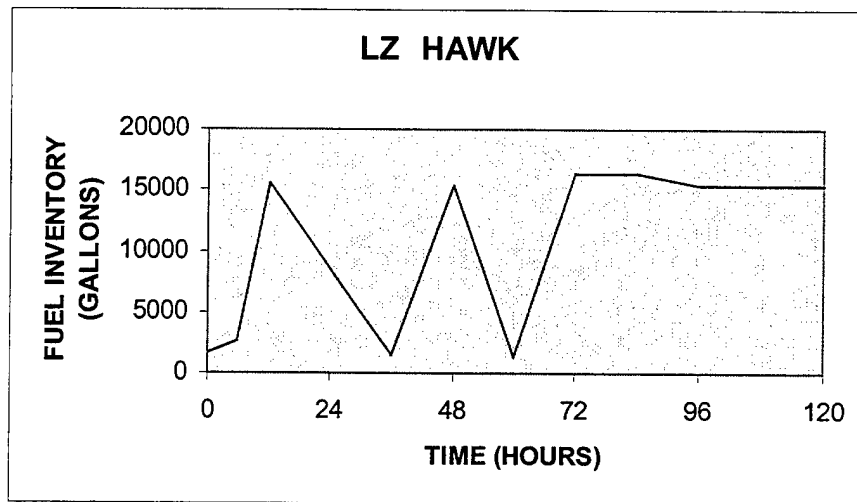

Figure 28. BLT Group 3 Fuel Inventory Levels (Scenario 2, 50 nm)



**Figure 29. Landing Zone Eagle Fuel Inventory Levels
(Scenario 2, 70 nm)**



**Figure 30. Landing Zone Hawk Fuel Inventory Levels
(Scenario 2, 70 nm)**

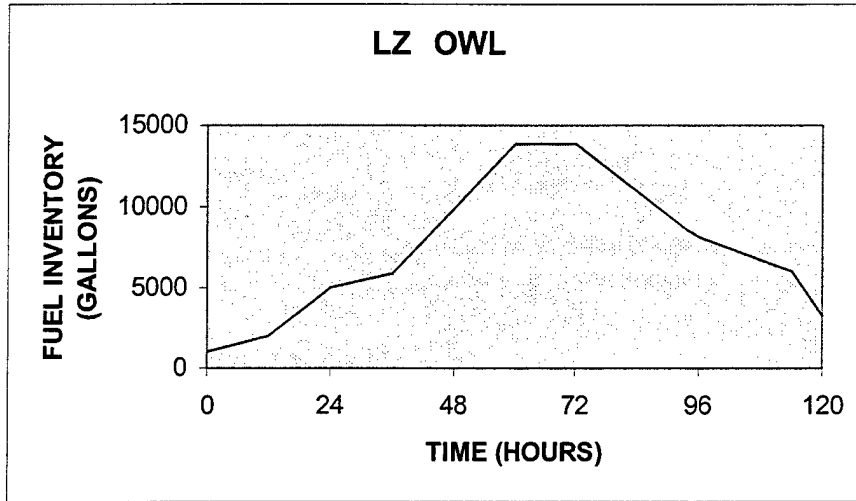

**Figure 31. Landing Zone Owl Fuel Inventory Levels
(Scenario 2, 70 nm)**

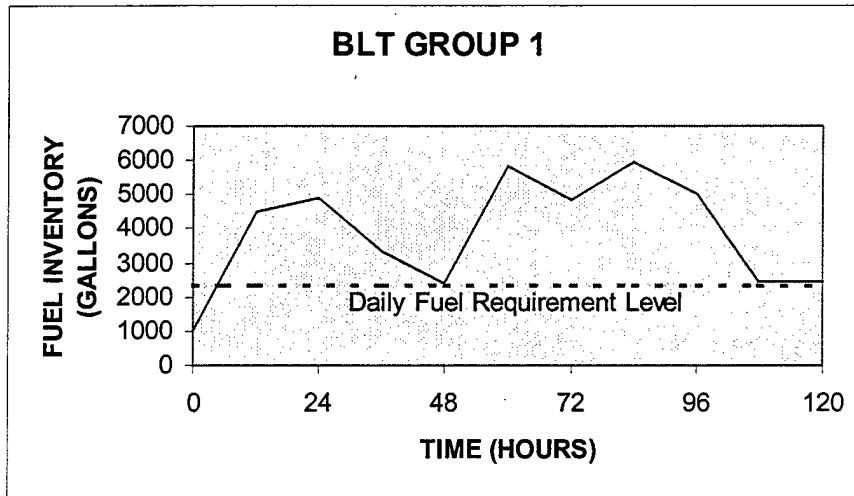

**Figure 32. BLT Group 1 Fuel Inventory Levels
(Scenario 2, 70 nm)**

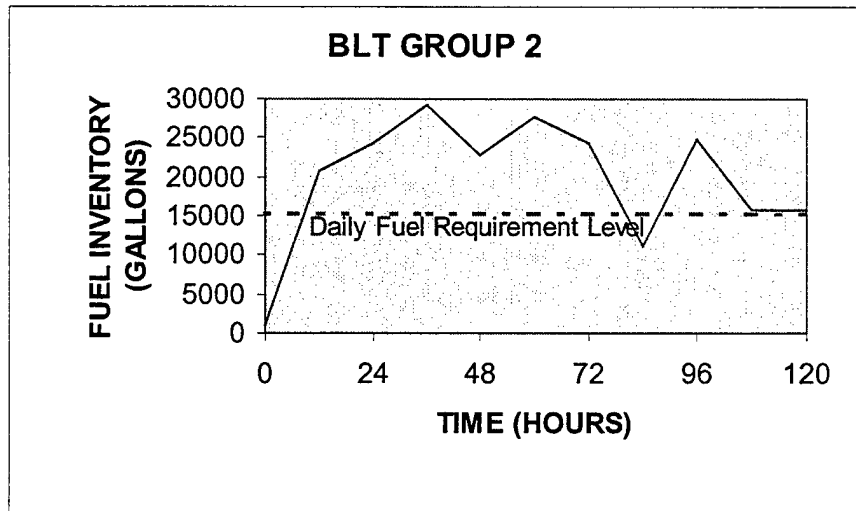

**Figure 33. BLT Group 2 Fuel Inventory Levels
(Scenario 2, 70 nm)**

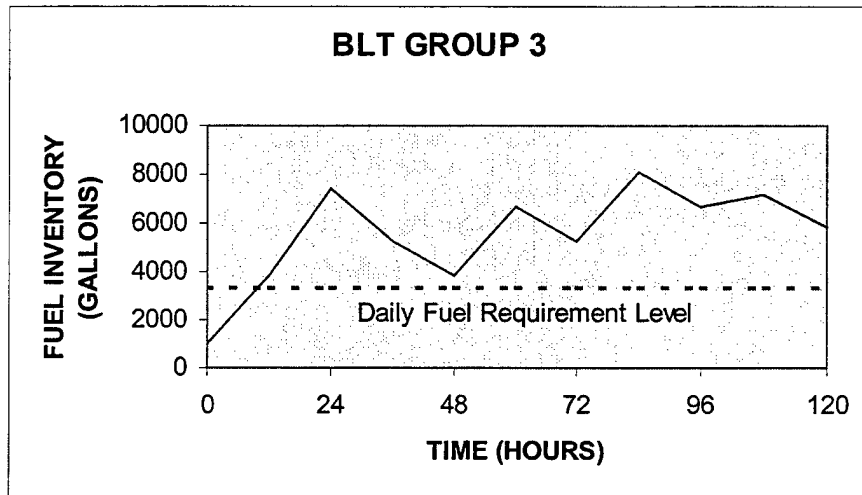

**Figure 34. BLT Group 3 Fuel Inventory Levels
(Scenario 2, 70 nm)**

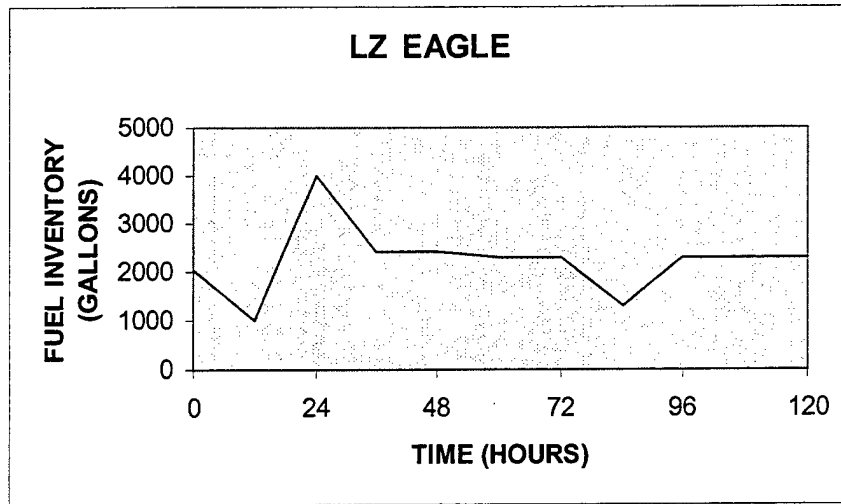

**Figure 35. Landing Zone Eagle Fuel Inventory Levels
(Scenario 2, 100 nm)**

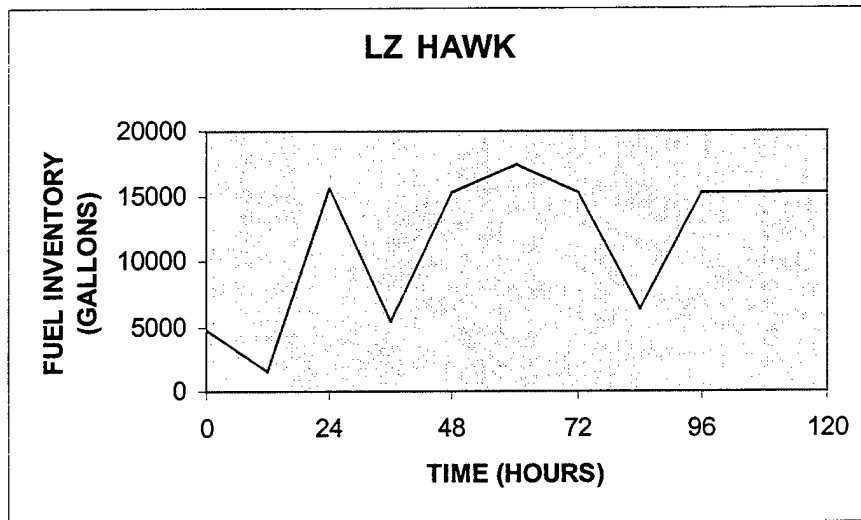

**Figure 36. Landing Zone Hawk Fuel Inventory Levels
(Scenario 2, 100 nm)**

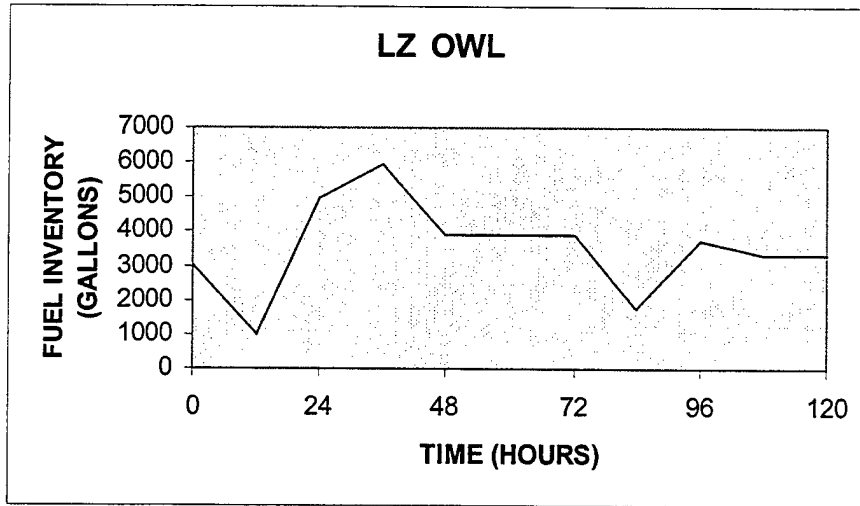

**Figure 37. Landing Zone Owl Fuel Inventory Levels
(Scenario 2, 100 nm)**

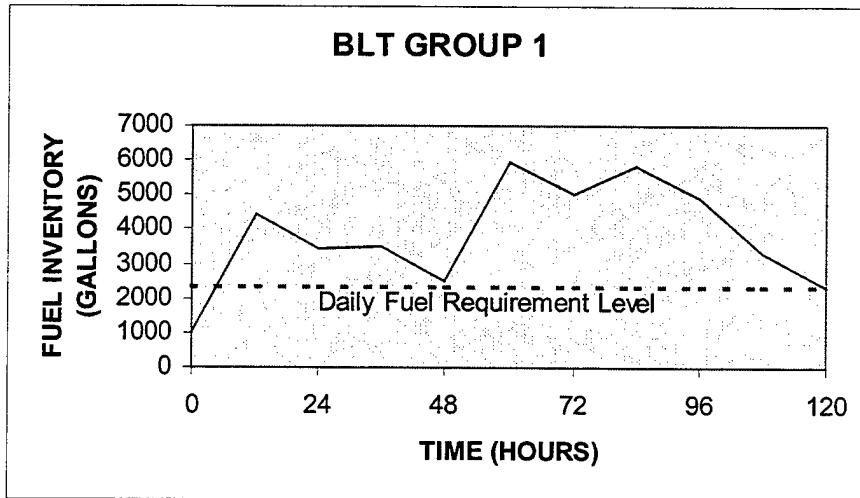

**Figure 38. BLT Group 1 Fuel Inventory Levels
(Scenario 2, 100 nm)**

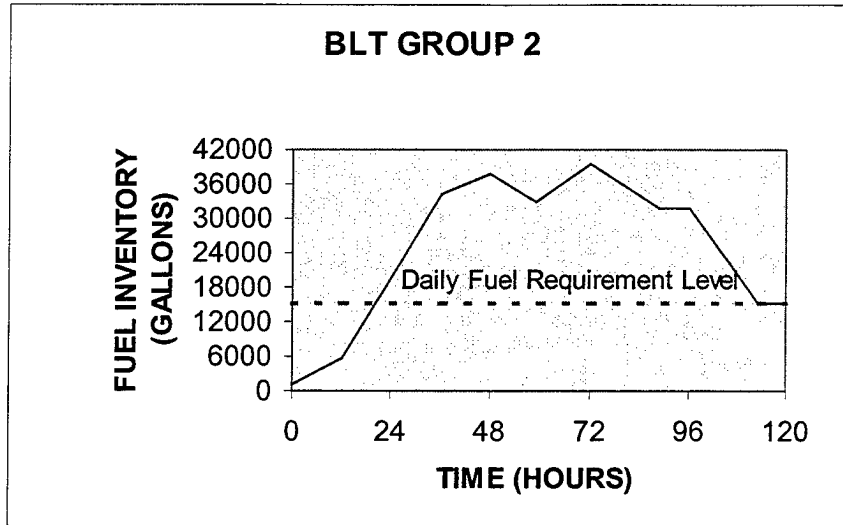

Figure 39. BLT Group 2 Fuel Inventory Levels (Scenario 2, 100 nm)

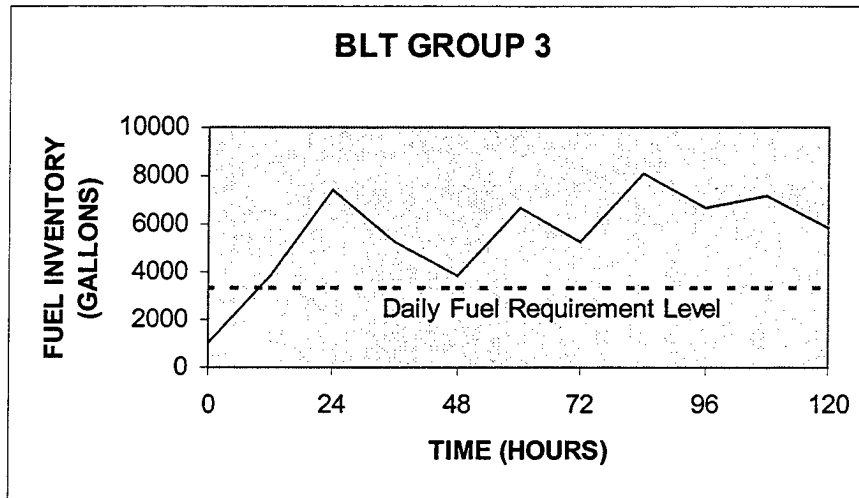

Figure 40. BLT Group 3 Fuel Inventory Levels (Scenario 2, 100 nm)

INITIAL DISTRIBUTION LIST

	No. Copies
1. Defense Technical Information Center..... 8725 John J. Kingman Rd., STE 0944 Fort Belvoir, VA 22060-6218	2
2. Dudley Knox Library..... Naval Postgraduate School 411 Dyer Rd. Monterey, CA 93943-5101	2
3. Defense Logistic Studies Information Exchange..... U.S. Army Logistics Management Center Fort Lee, VA 23801-6043	1
4. Deputy Chief of Naval Operations (Logistics)..... ATTN: LCDR Carolyn Kresek, N421C 2000 Navy Pentagon Washington, DC 20350-2000	1
5. Professor David Schradly..... Code OR/So Naval Postgraduate School Monterey, CA 93943-5000	1
6. Harold A. Viado, LT, USN..... 7639 Midwood Drive Charleston, SC 29420	3
7. Professor R. Kevin Wood..... Code OR/Wd Department of Operations Research Naval Postgraduate School Monterey, CA 93943	1
8. Kevin Maher, CDR, USN..... Code OR/MK Department of Operations Research Naval Postgraduate School Monterey, CA 93943	1