

INTERNET DOCUMENT INFORMATION FORM

A . Report Title: A Single-Point Mooring System for Direct Pumpout of Hopper Dredges

B. DATE Report Downloaded From the Internet: 07/06/99

C. Report's Point of Contact: (Name, Organization, Address, Office Symbol, & Ph #):
Dredging Operations Technical Support
Attn: Dr. Engler (601) 634-3624
3909 Halls Ferry Road
Vicksburg, MS 39180-6133

D. Currently Applicable Classification Level: Unclassified

E. Distribution Statement A: Approved for Public Release

F. The foregoing information was compiled and provided by:
DTIC-OCA, Initials: __VM__ Preparation Date 07/06/99

The foregoing information should exactly correspond to the Title, Report Number, and the Date on the accompanying report document. If there are mismatches, or other questions, contact the above OCA Representative for resolution.

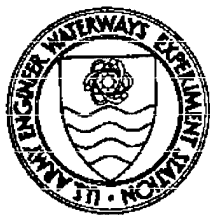

Dredging Research

Technical Notes



A Single-Point Mooring System for Direct Pumpout of Hopper Dredges

Purpose

This technical note describes a direct pumpout (DPO) system for use with hopper dredges, operating and design criteria for the DPO, initial mooring system designs, and the final DPO and mooring system selected. Short descriptions are provided of how the system operates, including transportation, assembly, and installation.

Background

The U.S. Army Corps of Engineers performs maintenance dredging with its four hopper dredges and also contracts for maintenance dredging by fifteen industry-owned hopper dredges. Annually the Corps dredges about 250 million cu yd of maintenance material from United States waterways. Significant amounts of this dredged material could be used for beneficial uses if an easier and less expensive means were available to deliver the dredged material to a site where it could be used. For example, clean sand could be placed on eroding beaches or fine-grained materials could be used to supplement wetlands. The Corps desires to increase beneficial uses of dredged material by lowering the delivery cost, making cost sharing with local sponsors a more attractive option.

Present equipment used to perform direct pumpout of hopper dredges was not designed for this purpose; existing equipment was adapted to meet the specific need. With increasing opportunities for beneficial uses of dredged material, the Corps desired a commercially available mooring system able to provide open-ocean DPO for the U.S. hopper dredge fleet.

The Corps of Engineers contracted with SOFEC, Inc. to describe several DPO systems capable of meeting Corps requirements; with Corps input, select a single system that would best meet Corps requirements; and provide a detailed preliminary design of the entire DPO system including the buoy, swivel, floating and underbuoy hoses, mooring hardware, and suggested transportation and installation procedures. The intent of this effort

was to allow a Corps district office or contractor with the need for such a system to use the preliminary design as a vehicle for developing final design and fabrication drawings. The results of the study are contained in two reports (SOFEC, Inc. 1992a, 1992b).

Additional Information

For additional information, contact Mr. James E. Clausner, (601) 634-2009, or the manager of the Dredging Research Program, Mr. E. Clark McNair, Jr., (601) 634-2070.

Direct Pumpout

Direct pumpout is a common method of removing dredged material from hopper dredges. A hopper dredge fills its hoppers as it dredges the bottom. The dredge then moors to a structure, buoy, or multiple buoy berth. Hoses connected to a pipeline extending to shore are attached to the hopper dredge discharge manifold. The dredge mixes the dredged material with water to form a slurry and pumps the slurry from its discharge manifold through the hoses and pipeline to a designated discharge location.

Design Criteria

The mooring system design was based on three Corps hopper dredges, the *Wheeler*, *Essayons*, and *McFarland*. Design loads and system analysis were based on the displacement and draft of the largest of these vessels, the hopper dredge *Wheeler*. Because the *Wheeler* is one of the largest hopper dredges in the United States, the mooring system design is applicable to most of the U.S. hopper dredge fleet. The *Wheeler* is 408 ft long and has a 78-ft beam and a 29.5-ft draft.

Operational weather conditions were chosen to fit the maximum operating environment for the dredges. The mooring was designed for the following operational and survival conditions:

Design Environmental Conditions*		
	Operational	Survival
Significant wave height, ft	6	10
Wind velocity, knots	30	30
Current velocity, knots	2	2
* Directions of the environmental forces were chosen to be consistent with nearshore conditions: current parallel to the shoreline, and wind and waves perpendicular to the shoreline.		

The mooring system was designed for operation in a water depth of 30 to 45 ft; however, operation is possible in water depths up to 75 ft with a slight reduction in capabilities. The distance of the mooring system from shore is limited by the hopper-dredge pumping capacity. The shallow slopes along parts of the east and gulf coasts will often require the dredge to operate in water depths very close to its maximum draft of approximately 30 ft.

The following operational criteria were also required for the mooring design:

- Transportable by truck or rail.
- Assembled rapidly.
- Installed with a minimum of lift support and diver assistance.
- Recoverable and reusable.

Mooring Concepts

Four concepts were considered for mooring the hopper dredge.

- Guyed tower.
- Tension leg platform (TLP).
- Single-anchor leg mooring (SALM).
- Catenary-anchor leg mooring (CALM).

A CALM system was chosen for further study and preliminary design due to its ability to be transported in truck-size packages and assembled quickly. Also, it proved to be the least costly to fabricate. SOFEC's Phase I report (1992a) gives additional details of the various mooring systems considered.

The DPO System

The DPO buoy in Figure 1 is a capsule-shaped buoy that is 28 ft long by 11 ft 6 in. wide by 7 ft 6 in. deep. Although not the conventional shape of a mooring buoy, the shape was chosen to facilitate towing the buoy and placement on flatbed trucks. The buoy can be disassembled into four components: buoy hull, fluid piping, fluid swivel, and mooring table.

The buoy hull serves as the foundation for the fluid piping. Slurry from the dredge enters the buoy through a floating hose connected to the fluid piping just above the water at the outer edge of the buoy. Piping is designed to contain a minimum amount of bends to reduce areas of high

abrasion. Slurry travels through the piping to a fluid swivel. Slurry leaves the buoy through an underbuoy hose that is connected to the fluid swivel and leads to a submerged steel pipeline to the discharge area.

The fluid swivel is an in-line swivel currently used by the dredge industry. It contains bronze bushings that reduce the need for seals or the extensive need for maintenance that roller bearings would require. The lower end of the fluid swivel contains a quick-release flange to assist in connecting the underbuoy hose.

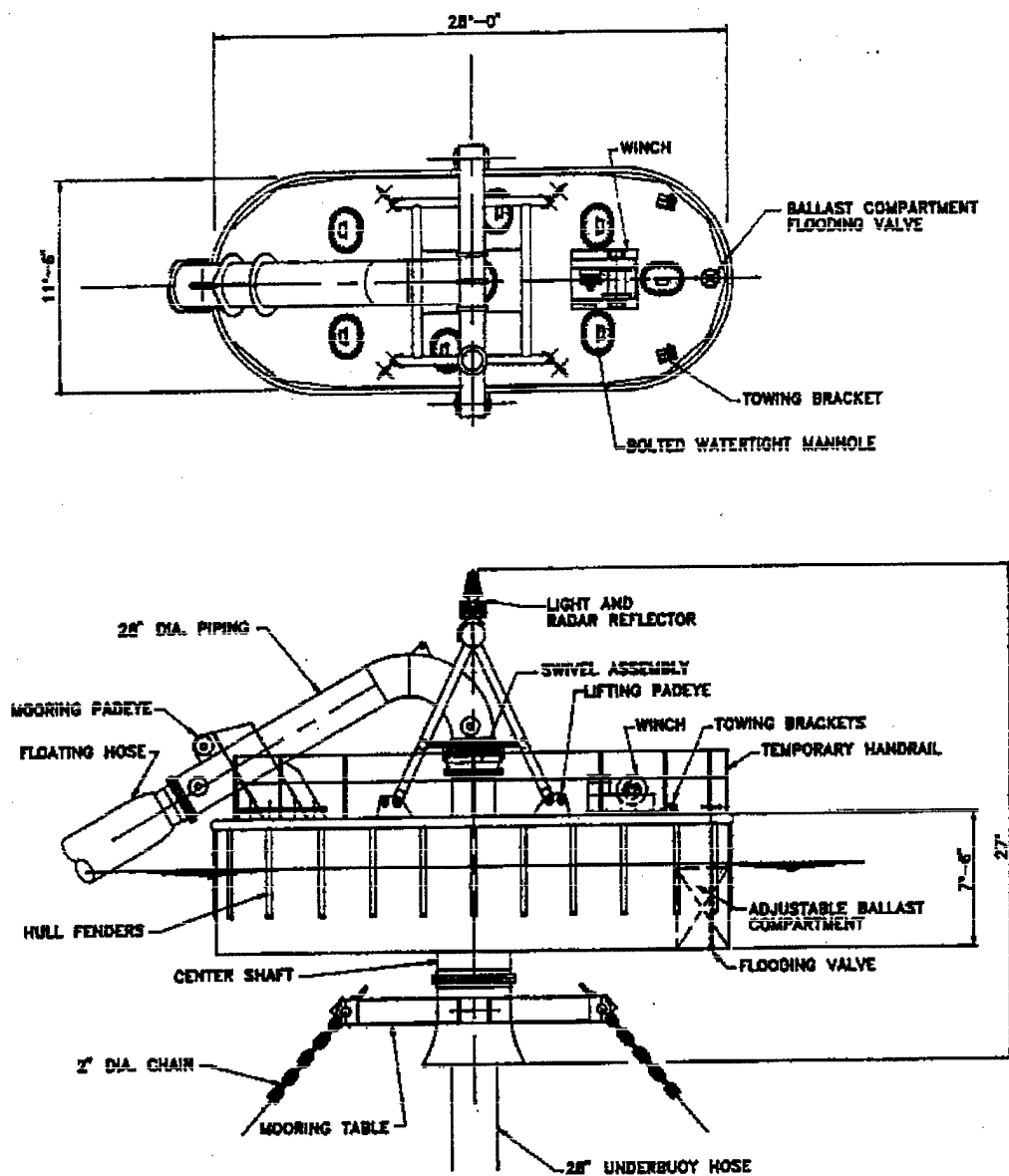

Figure 1. DPO system mooring buoy

Near the fluid piping/floating hose connection, a mooring padeye provides for connection of a mooring hawser. The hawser transfers the mooring forces from the dredge to the buoy.

The buoy is designed for a 28-in. pipeline. As a general rule, dredges with discharge pipe diameter within ± 2 in. of the shore discharge pipeline can efficiently use the shore discharge pipeline. Thus, this DPO buoy design is suitable for use with dredges having discharge pipe diameters ranging from 26 to 30 in. This range of diameters covers most of the U.S. dredge fleet with DPO capability.

The buoy rotates about a shaft that runs through the centerwell of the buoy. The center shaft contains two permanently lubricated bronze bushings located at the top and bottom of the centerwell of the buoy. A 48-in.-diam flange is located at the bottom of the center shaft. This flange provides the mechanical connection between the buoy and the mooring table.

The mooring table extends below the buoy and provides locations for connecting the mooring chains to the buoy. The mooring table also provides a bell fairing to reduce chafing of the underbuoy hose.

Floating and underbuoy hoses for this mooring system are standard commercially available hoses currently used in the dredging industry.

The mooring chains consist of four legs, each 600-ft-long, 2-in.-diam ORQ (Oil Rig Quality) stud link chain. Mooring anchors may either be 10,000-lb Navy Navmoor or 6,000-lb Bruce International FFTS anchors.

Figure 2 shows the installed mooring system during the DPO process.

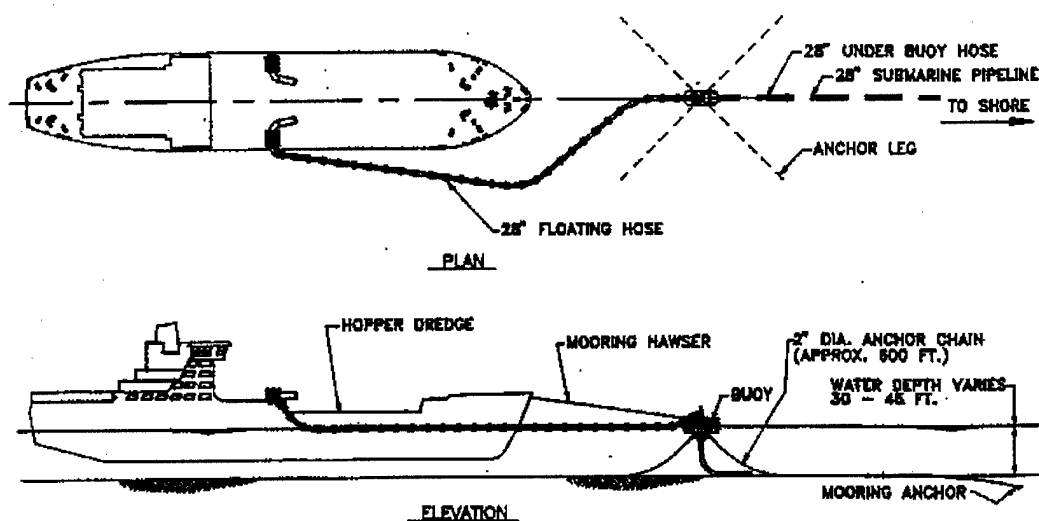

Figure 2. System general arrangement

System Operation

Transportation

The CALM system can be transported by truck, rail, or barge to the assembly location. Figure 3 shows the CALM buoy packaged for transport by truck. Components of the system can be consolidated and transported on standard flatbed tractor trailer rigs. The entire system can be transported by as few as six trucks. For ocean transport the entire system also can be arranged on a standard 60- by 120-ft cargo barge.

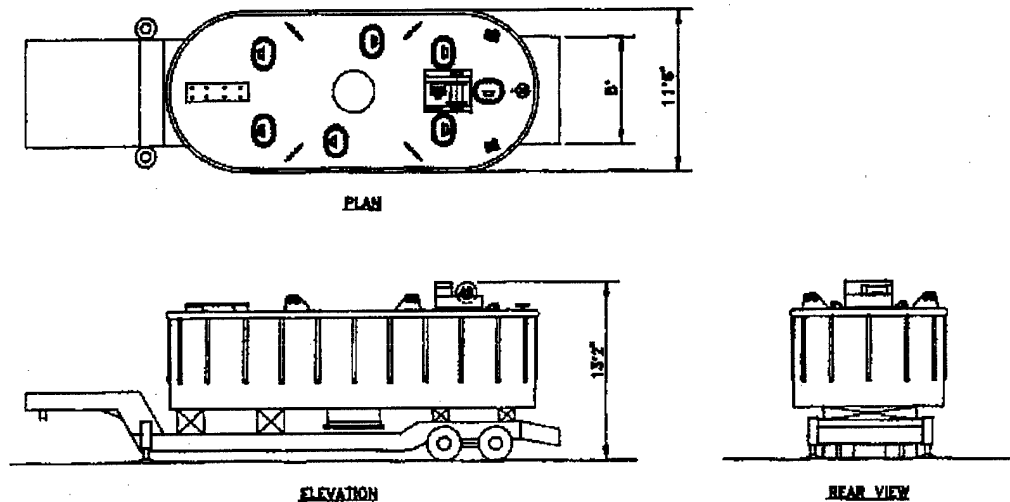

Figure 3. Mooring buoy truck transport configuration

Assembly

The CALM system is assembled by attaching the mooring platform to the 48-in.-diam flange located at the bottom of the buoy (Figure 4). The fluid swivel (Figure 1) is then attached to the buoy top deck, followed by the attachment of the piping to the fluid swivel and to the buoy deck at the outer edge of the buoy. The buoy is then lifted into the water by a shore-based crane. For short tows, the floating hose can be attached to the piping before towing.

Assembly requires 300 ft of dock space adjacent to a 250- by 300-ft staging area. Minimum crane lifting capacity required for assembly and launch is 60,000 lb at 20 ft. The buoy can be assembled and installed on site in one week. Additional dock space, a second crane, and additional personnel can reduce the total time for assembly and installation by one or two days.

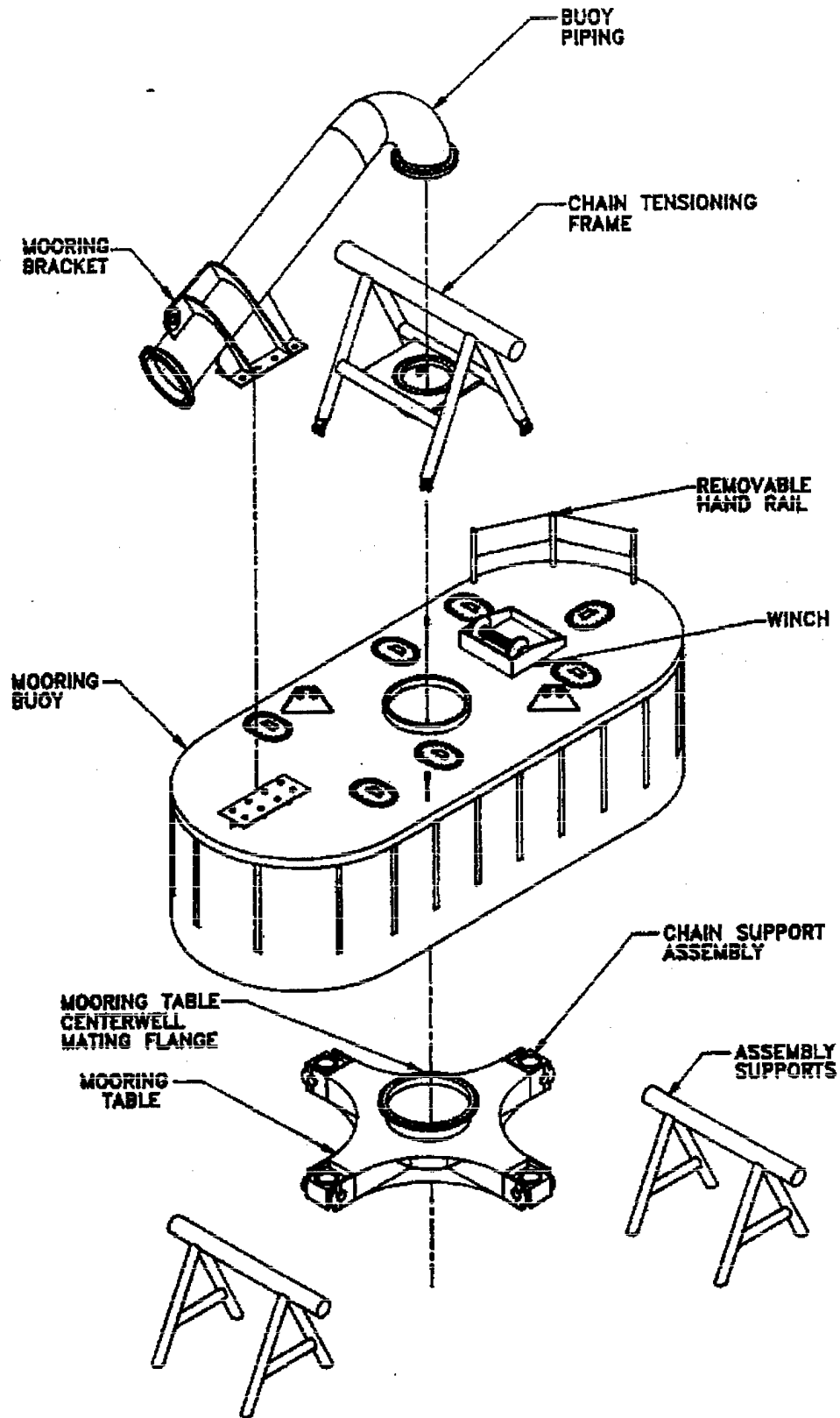

Figure 4. Mooring buoy assembly

Installation

Once the CALM buoy is assembled, a tow tug is connected to the towing padeyes on the buoy deck opposite the piping. The capsule shape of the buoy allows the buoy to be towed at greater speeds and provides a more stable tow than a conventional cylindrical buoy. While the buoy is under tow to the installation location, an anchor-handling tug is used to install the four mooring legs and the mooring anchors. The crew of the tug will tension the chains to set the anchors before buoy arrival. Chains will be laid close to the pipeline/underbuoy hose connection. Pickup buoys will be attached to each mooring leg.

As the chains are being installed, the pipeline will be assembled on the shore, floated into position, and lowered to the sea floor. Any pipeline stabilization required will be undertaken while the buoy chains are being attached.

When the buoy arrives at the installation location, the chain legs are attached to the mooring platform and tensioned until the proper chain catenary is achieved.

The underbuoy hoses are then pulled through the guide on the mooring platform and connected to the lower end of the fluid swivel. If the floating hoses were not installed at the shore, the connection is made between the floating hoses and the buoy piping. The hawser is connected to the mooring padeye to complete the system installation.

Assembly and installation procedures are described in greater detail in SOFEC's Phase II report (1992b).

Conclusions

A detailed preliminary design for a DPO system for use with U.S. hopper dredges has been developed. To meet operational requirements of use in shallow (30 ft) and logistical requirements for rapid transport (lightweight, easy assembly, and truck transportable), a capsule-shaped buoy using a CALM mooring system with a separate mooring platform was designed. The buoy is 28 ft long by 11 ft 6 in. wide by 7 ft 6 in. deep, and weighs approximately 30 short tons. Subsequent detailed design and fabrication of this system will depend on Corps district-specific requirements.

Acknowledgements

The following Corps of Engineers staff provided important contributions during development of this system: Messrs. Ron Kreh and Robert Johnson (U.S. Army Engineer District, Philadelphia), Mr. John Kelly (U.S. Army Engineer District, New Orleans), Mr. Jerry Gompers (U.S. Army Engineer District, Portland), Mr. Thomas Chisholm (U.S. Army

Engineer Waterways Experiment Station), and Ms. Virginia Pankow (U.S. Army Engineer Water Resources Support Center).

References

SOFEC, Inc. 1992a (May). "Dredge Mooring Study, Conceptual Design; Phase I Report," Contract Report DRP-92-1, report prepared by SOFEC, Inc., for the U.S. Army Engineer Waterways Experiment Station, Vicksburg, MS.

SOFEC, Inc. 1992b (May). "Dredge Mooring Study, Recommended Design; Phase II Report," Contract Report DRP-92-2, report prepared by SOFEC, Inc., for the U.S. Army Engineer Waterways Experiment Station, Vicksburg, MS.