

**A Global Positioning System
Receiver for Monitoring
Ionospheric Total Electron
Content**

Kyriaky Eftaxiadis, Dr Manuel A.
Cervera and Dr Richard M. Thomas

DSTO-TR-0742

DISTRIBUTION STATEMENT A
Approved for Public Release
Distribution Unlimited

19990713 138

A Global Positioning System Receiver for Monitoring Ionospheric Total Electron Content

Kyriaky Eftaxiadis, Dr Manuel A. Cervera, Dr Richard M. Thomas

**Surveillance Systems Division
Electronics and Surveillance Research Laboratory**

DSTO-TR-0742

ABSTRACT

A system based on a NovAtel MiLLennium L1/L2 dual frequency Global Positioning System (GPS) satellite receiver has been developed to monitor ionospheric Total Electron Content (TEC) and to detect ionospheric scintillation. Software has been written to control the logging of data from the receiver to an Iomega Jaz 1 Gbyte removable disk unit. Real time displays on the Notebook screen permit the inspection of both slant and vertical TEC values taken over the preceding 24 hours, together with the locations of satellites currently in view. The system is suitable both for long term unattended routine data gathering and for more intensive short term campaigns. Two receiver system units have been deployed in Indonesia and Malaysia for the purpose of monitoring the effects of the equatorial ionosphere on GPS navigation performance as the current solar cycle approaches its 11 year maximum in activity.

RELEASE LIMITATION

Approved for public release

DEPARTMENT OF DEFENCE
DEFENCE SCIENCE & TECHNOLOGY ORGANISATION | **DSTO**

Published by

*DSTO Electronics and Surveillance Research Laboratory
PO Box 1500
Salisbury South Australia 5108 Australia*

*Telephone: (08) 8259 5555
Fax: (08) 8259 6567
© Commonwealth of Australia 1999
AR-010-671
April 1999*

APPROVED FOR PUBLIC RELEASE

A Global Positioning System Receiver for Monitoring Ionospheric Total Electron Content

Executive Summary

A system has been built around a dual-frequency NovAtel MiLLennium™ Global Positioning System (GPS) receiver in order to measure the Total Electron Content (TEC) of the ionosphere and to detect radio wave scintillation.

The software has been designed and developed to provide interactive control of the receiver and the logging of its data to an external removable disk. In addition, it features a graphical user interface which includes displays both in real-time and for the previous 24 hours of satellite locations and measured TEC values. Adequate calibration of TEC values is widely recognised as a difficult problem and in this implementation, calibration of the real-time results has been achieved satisfactorily to first order. The real-time displays make the equipment particularly useful for campaigns, but the more useful application is for routine unattended logging.

Two systems have been deployed, one each in Malaysia and Indonesia under the Regional Engagement program. The intent is to monitor both ionospheric behaviour and GPS performance in equatorial regions as we approach the next peak in solar cycle activity in about the year 2000.

Authors

Miss Kyriaky Eftaxiadis
Surveillance Systems Division

Kyriaky Eftaxiadis graduated from the University of Adelaide in Electrical & Electronic Engineering with Honours in 1997 . She has been employed by Surveillance Systems Division since that time, working on GPS systems performance related tasks.

Dr Manuel A. Cervera
Surveillance Systems Division

Manuel Cervera is a Research Scientist working for the Sensor Environment & Electromagnetics Group of Surveillance Systems Division. He graduated with a PhD in the field of Meteor Physics in the Atmospheric Physics Group of the Department of Physics and Mathematical Physics at the University of Adelaide in 1996. Since working for the Surveillance Systems Division, his interests have included the disturbed ionosphere and its effect on trans-ionospheric radio signals.

Dr Richard M. Thomas
Surveillance Systems Division

Richard Thomas graduated from Adelaide University with BSc(Hons) in Physics in 1967 and with a PhD in X-ray Astronomy in 1971. He has been with the Jindalee team since 1979, his more recent work involving studies of JORN intersite isolation and the OTHR clutter environment. Most recently, he has overseen the establishment of a network of GPS receivers in Australia, Papua New Guinea and South-East Asia in order to provide data on the effect of equatorial ionospheric irregularities on GPS navigation.

Contents

1. INTRODUCTION	1
2. THE GPS SYSTEM.....	2
3. PROPAGATION EFFECTS.....	3
3.1 Ionospheric Delay and TEC	3
3.2 The Disturbed Ionosphere	4
3.3 Slant and Vertical TEC	4
3.4 Multipath	5
3.5 Tropospheric and Protonospheric Delays	6
4. THE TEC RECEIVER SYSTEM.....	7
5. GPS TEC RECEIVER SOFTWARE.....	10
5.1 Introduction.....	10
5.2 Control and Logging Software	10
5.2.1 Input/Output Communication Software.....	10
5.2.2 Logging Command Syntax	14
5.3 Real Time Processing Software	15
5.3.1 Data Extraction	16
5.3.2 Calculation of Slant TEC and Carrier Phase TEC	17
5.3.3 Calculation of Vertical TEC.....	18
5.3.4 Noise Mitigation.....	18
5.4 Graphical User Interface.....	19
6. CALIBRATION OF THE TEC RECEIVERS.....	21
7. CONCLUSION	25
REFERENCES.....	26

1. INTRODUCTION

GPS receivers are being used increasingly for all-weather precision navigation over land, sea and in the air by both military and civilian users. However, the Earth's ionosphere is capable of corrupting the navigation output of a receiver. For example, it is well known that the reception of signals from GPS satellites orbiting at altitudes of 20,000 km can be disrupted by disturbances in the ionospheric F-region below 1,000 km (Klobuchar, 1996). Such disturbances in propagation result mainly from night-time plasma irregularities which can be particularly troublesome in the equatorial region and during times of high solar activity. These irregularities cause scintillations in phase and amplitude to be imposed on the signals received from the satellites, leading to degraded navigation performance and even complete signal loss for the duration of the scintillation activity.

The dual frequency GPS receiver system described in this report provides a means of monitoring the effect of the ionosphere on GPS signals. It is particularly intended to measure the integrated ionisation between satellite and receiver, but is also capable of detecting scintillation. Operation at the L1 and L2 frequencies simultaneously permits measurement of the relative phase delay between the two signals, producing an unambiguous determination of the slant Total Electron Content (TEC), or the number of electrons in a column of cross-sectional area 1 square metre following the signal path between the satellite and the receiver. For a single frequency GPS receiver, ionospheric delay cannot be determined uniquely, but must be estimated from a model, with an uncertain effect on the final navigation solution. Thus TEC is a significant concern for users of single frequency GPS receivers and particularly for those located under the equatorial ionospheric anomaly region, where the reliability of the GPS provided model is open to question.

We hope that the receiver system described in this report will make a positive contribution to developing a model of TEC which has direct applicability in our region. The receiver should also be capable of detecting scintillation, and thereby play a role in support of faster sampling ionospheric scintillation monitors (Van Dierendonck et al, 1993). In addition, TEC data has the potential to complement data from ionospheric sounders throughout the region and contribute to improved management of High Frequency (HF) communications.

2. THE GPS SYSTEM

The GPS navigation system comprises three distinct "segments" (Sonnenberg, 1988; Ackroyd and Lorimer, 1990). The space segment consists of the constellation of 24 satellites transmitting coded signals downward to receivers on the Earth's surface, the control segment involves a hand-full of precisely located ground stations used for monitoring satellites and sending upward signals for the engineering control of each satellite and its transmitted codes and waveforms, and the user segment includes anyone with a GPS receiver who is making use of the transmitted signals. Satellites are located equispaced around each of six circular orbital planes inclined at 55 degrees to the plane of the Earth's equator. The orbital altitude is 20 200 km, with an orbital period of 12 hours. The geometry of the satellite constellation is such that, from any point on the Earth's surface with a reasonably unobstructed horizon, signals from at least four satellites will always be available in the line of sight and it will therefore be possible to solve for the four unknowns of receiver latitude, receiver longitude, receiver altitude and the combined satellite/receiver timing error (which although small, is non-zero and must be found and corrected for).

Each satellite continuously transmits on 2 frequencies in the L-band of the microwave spectrum, at L1=1.57542 GHz and L2=1.2276 GHz respectively. The L1 and L2 carriers are phase coherent, both being derived from a common 10.23 MHz oscillator. They are both modulated by a common binary code, the so-called precision code (P-code), the use of which both allows the delay error introduced by ionospheric refraction to be eliminated from the final position determination, and as will be described below, permits the determination of the total electron content along the signal path. The encrypted P-code is unavailable to the general user. The L1 frequency is also modulated by the coarse acquisition code (C/A code) and is used by single frequency receivers.

A GPS receiver calculates its position by selecting the optimum configuration of four satellites and finding its range with respect to each satellite. Range is determined from the delay taken for the signal to travel from each satellite to the receiver, as measured by the difference between the satellite transmit time, which is known, and the signal reception time which is measured by auto-correlation. However, this difference does not take into account any error in the receiver's clock relative to the satellite's clock and therefore the range is only approximate and is called a pseudorange. Calibration of the clock error, or bias, is required in order to obtain a corrected range. Calculation of position by the receiver also requires a knowledge of satellite positions in the sky and to achieve this, besides transmitting the C/A and P codes, each satellite also

transmits a satellite ephemeris or almanac, which is a formatted navigation message containing orbital information, together with clock corrections, data for modelling ionospheric delays and satellite house-keeping information.

3. PROPAGATION EFFECTS

3.1 Ionospheric Delay and TEC

The ionosphere has a refractive index at radio frequencies which is different from unity and can affect GPS signals in a number of ways as they pass from satellite to ground (Klobuchar, 1996; Wanninger, 1993; Coco, 1991). One such effect is the addition of ionospheric delay to pseudorange and carrier phase observations which is difficult to correct in single frequency receivers. However, dual frequency receivers are able to exploit the physics of the ionosphere as a dispersive medium in which the refractive index is a function of frequency, and introduce corrections which remove these effects, at least to a first order.

The ionospheric time delay at the L1 carrier frequency f_1 is given by (Klobuchar, 1996)

$$t_1 = 40.3 \cdot (\text{TEC}) / (c f_1^2) \quad (1)$$

where c is the speed of light in free space. A dual frequency receiver measures the difference in delay between the 2 frequencies, $\Delta t = t_2 - t_1$, given by

$$\Delta t = (40.3/c) \cdot \text{TEC} / [(1/f_2^2) - (1/f_1^2)] \quad (2)$$

which can be rewritten in the form

$$t_1 = \Delta t [f_2^2 / (f_1^2 - f_2^2)] \quad (3)$$

where the delay t_1 can be regarded as the measured pseudorange at the L1 frequency. It is simple to see that a further rearrangement of the above equations will permit derivation of TEC, providing that all other sources of delay bias have first been removed.

In practice, calculation of TEC by the above means, using pseudorange data only, can produce a noisy result. It is desirable to also use the relative phase delay between the two carrier frequencies in order to obtain a more precise result. Differential carrier phase gives a precise measure of relative TEC variations but because the actual number of cycles of phase is not known,

absolute TEC cannot be found unless pseudorange is also used. Pseudorange gives the absolute scale for TEC while differential phase increases measurement precision.

3.2 The Disturbed Ionosphere

The above account is based on a consideration of a benign ionosphere in the absence of spatial and temporal irregularities and is suited to the measurement of an integrated quantity such as TEC. However, under some circumstances, irregularities in ionisation do exist and they can have the effect of imposing variations on the phase front of GPS signals. In addition, signals can be scattered in the ionosphere, leading to fading when the scattered wavefronts interfere with each other as they propagate towards the ground. The resulting phenomena of phase and amplitude scintillation can compromise GPS receiver performance, particularly in the equatorial region during night-time hours near the equinoxes and over periods of enhanced sunspot activity. The experimental study of scintillation usually requires a GPS receiver capable of sampling at a rate of about 50 Hz. The TEC receiver described in this report will sample much more slowly, at about 0.5 Hz, and so will not be capable of a faithful recording of scintillation. However, it will nevertheless provide an indication of when scintillation is present, since the related phase variations will be detected by the differential phase measurement and apparent rapid TEC variations will result. Other scientists have already used the rate of change of TEC as an indicator of scintillation activity (for example, Ho et al 1996). We also expect to monitor scintillation in this way, using the TEC receiver as a backup to our 50 Hz single frequency ionospheric scintillation monitors (Van Dierendonck et al, 1993).

3.3 Slant and Vertical TEC

Slant TEC is a measure of the total electron content of the ionosphere along the ray path from the satellite to the receiver, represented in Figure 1 as the quantity T_s . It can be calculated by using pseudorange and carrier phase measurements as described in Section 3.1. The receiver (known as a 'codeless' receiver because it does not require knowledge of the C/A or P pseudorandom noise codes), by cross correlating the L1 and L2 modulated carrier signals, obtains the time delay of the P code and the carrier phase difference. These are used to calculate the pseudorange and differential carrier phase respectively, and hence the slant code TEC and slant phase TEC respectively.

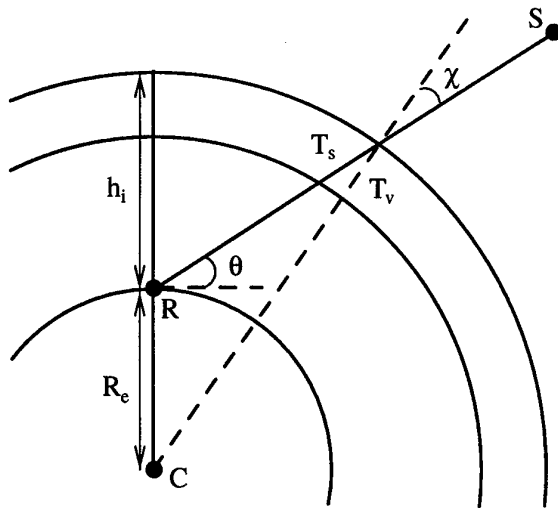

Figure 1 - Geometry of a GPS satellite-receiver link

As slant TEC is a quantity which is dependent on the ray path geometry through the ionosphere, it is desirable to calculate an equivalent vertical value of TEC which is independent of the elevation of the ray path. Vertical TEC enables TEC to be mapped across the surface of the earth. Figure 1 depicts the relationship between slant (T_s) and vertical (T_v) TEC. The two quantities are related by an obliquity factor, $O(\theta)$, as follows:

$$T_s = T_v \cdot O(\theta) \quad (4)$$

From simple trigonometry the obliquity factor can be shown to be

$$O(\theta) = 1 / \cos \left(\arcsin \left(\frac{R_e \cdot \cos(\theta)}{R_e + h_i} \right) \right) \quad (5)$$

where R_e is the mean radius of the Earth and h_i is the effective ionospheric height.

3.4 Multipath

When a signal arrives at a receiver via two or more different paths of different phase lengths (caused by the signal being reflected by nearby objects or the ground), interference between those signals occurs. This phenomenon is referred to as multipath and it affects the GPS code and to a smaller degree, the

carrier phase measurements. The accuracy of positions measured by a GPS receiver affected by multipath will be compromised.

The RMS (1σ) error typically introduced to the P-code pseudorange by multipath is about 1.2 m (Knight et al., 1998). This corresponds to an additional 1σ horizontal error of 1.8m on the horizontal position derived by the GPS receiver for a typical Horizontal Dilution of Precision (HDOP) of 1.5. Briefly, dilution of precision (DOP) is a geometrical factor based upon the relative satellite positions and is used to convert RMS pseudorange errors to equivalent positional errors (Milliken and Zoller, 1980). A fuller description of DOP is beyond the scope of this report. Converting the P-code pseudorange error to an error in TEC (using Equation 2) yields a value of 11.4 TECu at (1σ).

The ratio of multipath effects on two signals is proportional to their respective wavelengths (Klobuchar, 1996). Thus, the multipath effects observed on the L2 carrier (1227.6 MHz) is 120 times smaller than that of the P-code modulation (10.23 MHz). Therefore carrier phase measurements yield a precise, smooth rendition of TEC which is relatively unaffected by multipath. However, the phase ambiguity in the carrier phase measurements does need to be removed to yield absolute TEC and this is achieved by fitting the carrier phase TEC to the code TEC (described later). This process assumes that multipath is a zero mean process which may not necessarily be the case. If not, the absolute value of the ambiguity-resolved carrier phase TEC will have some residual multipath error in it.

3.5 Tropospheric and Protonospheric Delays

The ionosphere makes the principal contribution to GPS signal delay but the troposphere and protonosphere are also important (Klobuchar, 1996). Whereas the ionosphere introduces a range error of perhaps 30 m (in the zenith direction) which is both dispersive and variable, the tropospheric delay is on the order of 3m when dry and only 0.3m when wet (Davies and Hartmann, 1997). It is not frequency dependent and so does not contribute to a dual-frequency measurement of TEC.

The protonosphere is the region of ionised hydrogen which extends outwards from heights of about 1000 km and falls off only slowly with increasing altitude (scale height about 1000 km) (Klobuchar, 1996). The level of ionisation varies little throughout a 24 hour period. However, since the electron density in the F-region is stronger during daylight than at night, the TEC in the protonosphere amounts to about 10% during daylight, but is more significant at night, increasing to about 50% of the total. As is the case for the ionospheric

component, it is dispersive and therefore will be a component of the total TEC measured using a dual-frequency receiver. Protonospheric ionisation can be significantly depleted on a time scale of a day or two following a magnetic storm.

4. THE TEC RECEIVER SYSTEM

Our system hardware comprises a NovAtel L1/L2 MiLLenium OEM GPSCard receiver configured by GPSat Systems Australia Pty Ltd, together with a NovAtel type 503 Survey Antenna and Choke Ring designed to minimise the level of multipath interference. The receiver has 12 channels, that is, it can record data from up to 12 satellites simultaneously, is dual frequency, operating on L1 C/A code and L2 P code (see above) and is capable of sampling at a rate of 4 Hz if necessary. It is powered from an 18 volt DC power supply and controlled through the COM1 port by a Toshiba Satellite 200CDS/810 Notebook PC (Pentium 100) running Windows-95. The Notebook's real time clock is automatically set to Universal Time by the GPS receiver software (using the GPS data). Data are logged on an Iomega Jaz 1 Gbyte removable disk external drive and disks are changed on a periodic basis as they become full. A photograph of the complete system appears in Figure 2 and a technical block diagram appears in Figure 3.

NovAtel supply their proprietary graphical interface program called WinSat in order to facilitate the sending of commands to the receiver and to control data logging. However, it creates a single monolithic file for as long as it is allowed to run, whereas we prefer a separate file to be created for each day. Our special purpose logging software is described in greater detail in Section 6 below.

Other features of the system, which will also be described in greater detail in sections below, include real-time displays of slant and vertical TEC values recorded during the previous 24 hours, and the current azimuth and altitude of all satellites "in view". This real-time display feature will not be much utilised during normal routine data gathering, which will be largely unattended, but should prove to be most useful when scientific staff are on site during short and intense experimental campaigns.

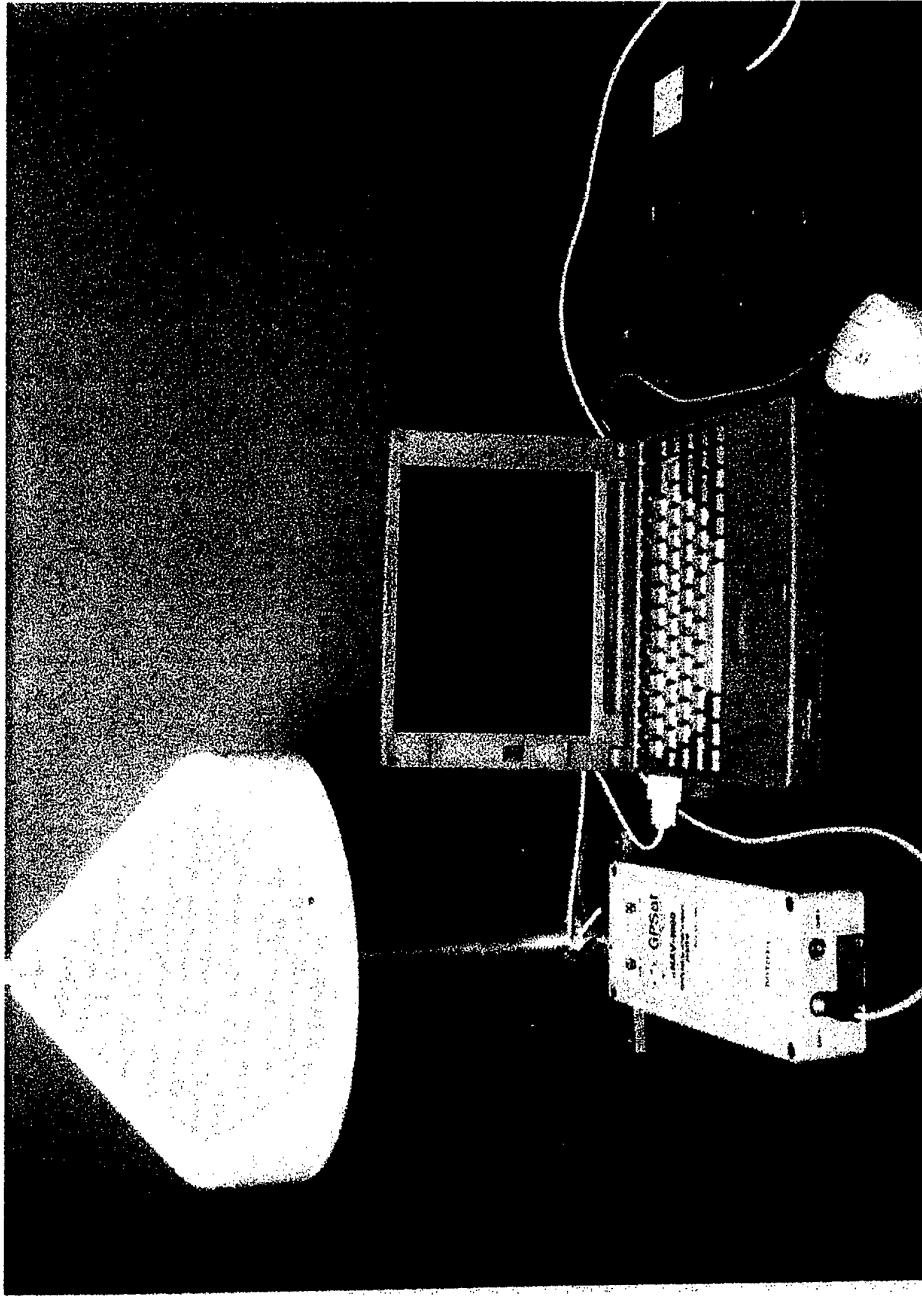

Figure 2- Photograph of the complete GPS TEC receiver system

GPS TEC RECEIVER

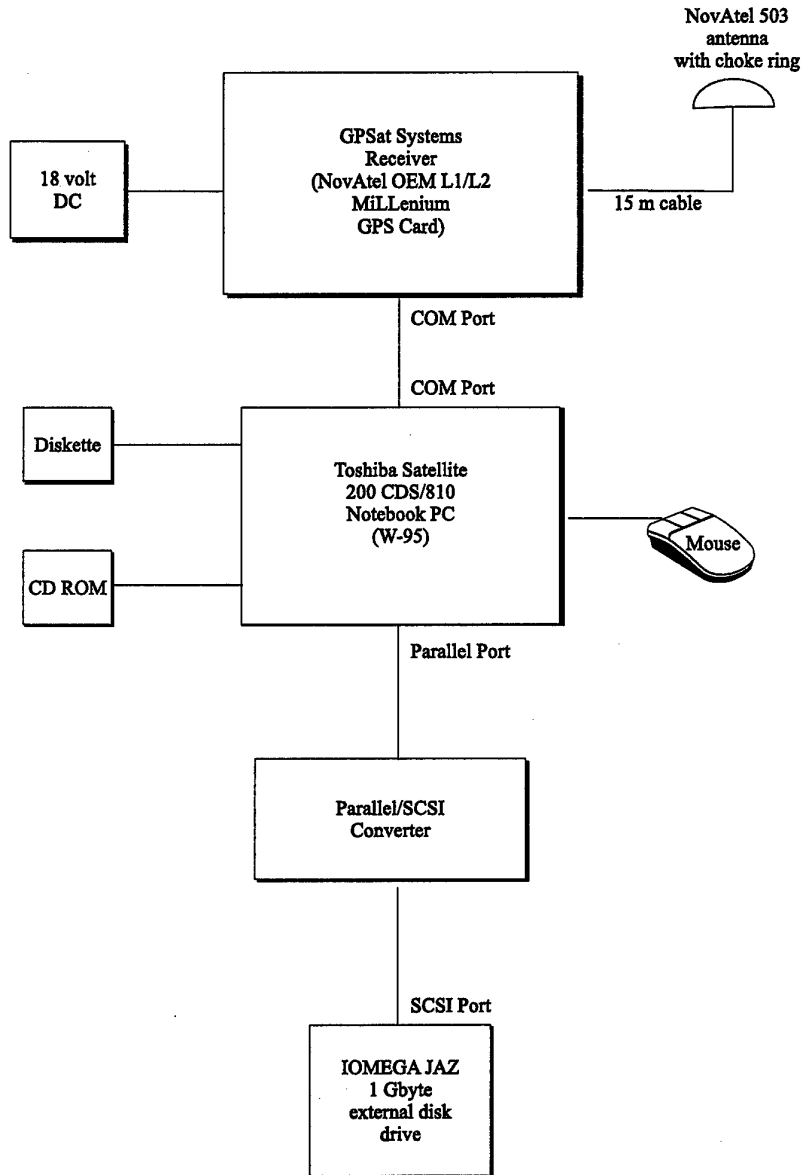

Figure 3- Block diagram of the complete GPS TEC receiver system

5. GPS TEC RECEIVER SOFTWARE

5.1 Introduction

The main objective for the system developed was the collection of raw GPS data that could then be used for detailed analysis of the ionosphere. This involved saving data to an external Jaz disk, with one data file produced per day. Such a simple system is sufficient for our purposes, however, it does not allow the operators nor any scientists on campaign to observe the behaviour of the ionosphere until weeks or months later, when the raw data has been processed off-line. Thus, some form of visual representation is desirable to allow the assessment of the behaviour of the ionosphere in real time. To achieve this end, graphical displays of ionospheric and satellite information were required to be developed and integrated into the system. This imposed the requirement that real time processing software be developed to produce TEC from raw GPS data. Issues which required consideration for real time TEC processing were: receiver calibration, multipath and other forms of interference, mitigation strategies, and the use of a suitable model of the ionosphere to convert slant TEC to vertical TEC. These will be discussed in greater detail in Section 5.3.

Having the above points in mind, the overall software system can be thought of performing three main functions: (1) controlling the operation of the receiver, (2) processing the raw GPS data in real time, and (3) displaying data in real time through a graphical user interface (GUI). This is represented by the flow chart in Figure 4. Specifications for the software were that a Windows 95 platform was to be used and that the GUI would allow operator control of the receiver and the graphical displays. It was decided to develop the software in Borland C++ v5.0 and integrate into it a graphics package called Graphics Server for the real time displays.

5.2 Control and Logging Software

5.2.1 Input/Output Communication Software

The first and most important aspect of the software was to develop code that would allow two way communication between the computer and the receiver in order to be able to control the receiver's operation. This involved developing code that would send to the receiver commands for set up, control and logging in a format defined by the receiver's manufacturer NovAtel. The code would also retrieve and store the data the receiver sent back. Communication with the

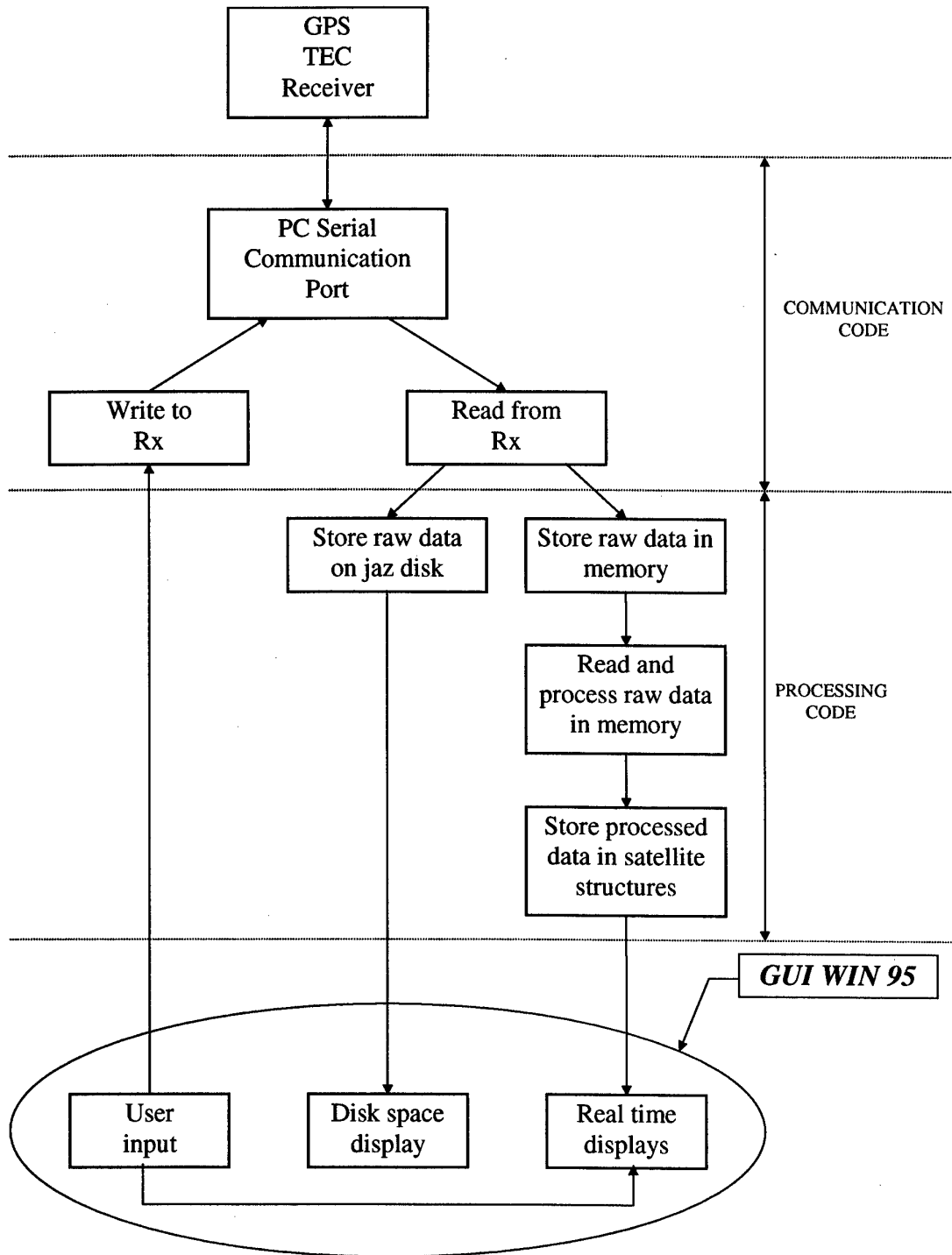

Figure 4 - Flow chart of receiver software

receiver was established through the RS-232 serial communication port, as indicated in Figure 4. The communication software is comprised of three sections - the set up, writing and reading sections, which will be described in greater detail below.

The communication port can be visualised as two buffers (arrays) of a given size in memory capable of storing data. One buffer is used to store data for transmission down the serial line (transmit buffer), and the other buffer is used to store incoming or received data from the serial line (receive buffer). Before communication between devices can be established, the size of these buffers must be assigned and all other relevant communication port parameters set. This is done in the set up section of the communications code, using what are known as the MicroSoft Win32 Communication Application Programming Interface (API) functions, a set of functions that enable programmers to set up and manipulate communication resources.

For the current system, transmit and receive buffers of size 10KB were selected by considering the maximum possible data byte count that could occur when logging the default data types, and allowing extra capacity to accommodate other data types that may be logged as well.

Other communication port parameters that need to be set include the baud rate, the number of data bits and stop bits, parity and flow control. By default the set up code configures the port with the values shown in Table 1. The baud rate of 9600 bps is the receiver default. Initially the computer must establish communication with the receiver at this baud rate, but it can be changed through the graphical user interface (GUI). Flow control or hardware handshaking is disabled due to the unavailability of this feature on the receiver's communication port.

baud rate	9600 bps
data bits	8
stop bits	2
parity	none
flow control	none

Table 1-Serial Port parameters

The writing section of the communications code involves sending commands (defined by NovAtel) in the form of text strings terminated with a carriage return to the communication port for transfer to the receiver. The code consists of a function which takes as an argument a file, and sends the contents of that

file down the serial port. The file can contain receiver set up, logging and control commands. During routine operation of the system, a default set of commands is stored in the file and written to the receiver. The option of sending a file with operator selected commands also exists, enabling logging of data types other than the default types.

Reading from the communication port is performed asynchronously. By asynchronous it is meant that the function is executed in the background, allowing other tasks to execute in the foreground. Performing asynchronous input/output is very important from the point of view of an application with a graphical user interface. The operator can interact with the application without having to wait for the write or read to complete before gaining control of the CPU. It is not as imperative for the writing function to be asynchronous in this particular application, due to the small amount of information (commands) to transmit to the receiver. However, it is critical for reading since data will be logged periodically (currently the period is set to 2s).

The approach taken to read asynchronously involved creating a separate thread (a series of instructions to be executed - written in C++ in this case) and using communication port timeouts. At present the priority of the thread is set to the default priority 'normal' of the computer, and the reading timeout is set to 50 ms. The reading timeout is the maximum time allowed to lapse between the arrival of two consecutive characters on the serial communication port line. It is used to flush the port receive buffer between successive data streams. Without the timeout, the contents of the buffer would not be flushed out until the buffer filled up with data, and clearly this is an unacceptable solution since the data will be used for real time processing. It is necessary to flush the data periodically as it arrives and follow this with the processing.

At a baud rate of 9600 bps, 0.8ms is required to transmit 1 byte of data, where 1 byte corresponds to the size of one character. Hence, to set the value of the timeout, the baud rate and the time duration to transmit a typical stream of data from the receiver to the computer required consideration. In this application the maximum possible default data byte count per stream is approximately 1.66 KB or 13600 bits. Thus at the given baud rate it would take approximately 1.4s to transmit this stream, and given that the period of logging is 2s, a 0.6s time interval remains to flush the contents of the receive buffer. A value of 50ms was selected for the reading timeout since a 50ms delay between characters is much greater than the time of 0.8ms taken to transmit an 8 bit character, and ensures that characters are not lost by flushing the buffer out too soon. Also, it is smaller than the 0.6s time difference between the end of the current data stream and the

beginning of the successive data stream, hence flushing of the buffer will occur before the next data stream begins transmission.

The incoming data received in the receive buffer of the serial port is firstly saved onto the Jaz disk, where a separate file is created for each day, and secondly copied into memory and used for real time processing. It is critical that the calculations involved in the processing stages are completed within the 0.6s time frame that exists between the end of the current data stream and the beginning of the next, otherwise the data in memory will be overwritten.

5.2.2 Logging Command Syntax

Logging commands sent to the receiver all follow the same general syntax defined by NovAtel, the receiver's manufacturer:

log port, data-type, trigger, period, offset

where the operator specifies all of the arguments following the *log* command. Commas or spaces can be used to separate the arguments in the logging command text string.

The argument 'port' is the communication port on the receiver from which the operator will be collecting the data, it will be either COM1 or COM2. The argument 'data-type' represents the actual data the operator wishes to collect. A large range of data types are available and documented in NovAtel's GPSCard™ Command Descriptions Manual. The argument 'trigger' specifies how often the data is to be collected by the receiver. There are three trigger types that are of interest in this application as shown in Table 2.

ONCE	immediately logs the selected data to the selected port once
ONCHANGED	logs the selected data only when the data has changed
ONTIME	immediately logs the selected data and then periodically logs the data at a frequency determined by the period and offset arguments.

Table 2 – Trigger Types

Finally the arguments 'period' and 'offset' are used in conjunction with a logging command that has specified the ontime trigger. The period specified in seconds, determines the frequency of logging and can be any value between 0.25s (4 Hz maximum) to 3600s. The offset allows the operator to offset logging

at the given period by a specified amount. An offset of zero is used in this application. Notice that the period and offset arguments are supplied only if the trigger is of type ontime, thus for all other trigger types only the port, data type and trigger are specified.

Four data types as listed in Table 3 with a period of 2s, were selected as defaults to be recorded routinely (see Novatel's GPSCard™ Command Descriptions Manual for a detailed breakdown of the log syntax). Approximately 50MB of data were collected per day at DSTO Salisbury when logging these data types.

The data types listed in Table 3 were selected in order to be able to calculate total electron content (TEC) for each GPS satellite-receiver link, and relate the TEC to the satellite position and site location. The RGEb log contains the pseudorange and carrier phase data that is required to actually calculate the TEC using the equations listed in Section 3. The SATB log is collected for elevation, azimuth and GPS time data. Positional data from POSB is required to examine site position under different ionospheric conditions and finally, the ephemeris log (REPB) is collected in the event that satellite orbital information be required for any analyses.

RGEb	binary channel range measurements, contains pseudorange and carrier phase data
SATB	satellite specific binary data, contains satellite data such as azimuth, elevation, GPS time
POSB	position binary data, contains site position coordinates
REPB	raw ephemeris binary data, contains satellite orbital and status information

Table 3- Default logs for routine data recording

It should be noted that it was originally planned to log RGEC (compressed binary) data instead of RGEb, but Dr Yue-Jin Wang of the Ionospheric Prediction Service (IPS) has pointed out that this format has a reduced dynamic range which causes SNR values to be clipped at both very small (<20dB) and very large (>51dB) extremes. Such clipping is undesirable, particularly at times of strong scintillation activity which are of direct interest to us.

5.3 Real Time Processing Software

For real time monitoring it was considered desirable to build into the software package a number of displays, including satellite location (azimuth and elevation) and TEC (both slant and vertical). To achieve this it was necessary to

process the raw data logs and extract both satellite related information and the data required to calculate slant and vertical TEC. Mitigation of spikes, cycle-slips and other noise effects in the carrier-phase data was important to yield reliable results and this will be described. The processing code, which was developed according to the flow chart illustrated in Figure 5, provides an approximate real time measure of TEC. A more precise calculation of TEC would be possible off-line using the data recorded on the Jaz disks.

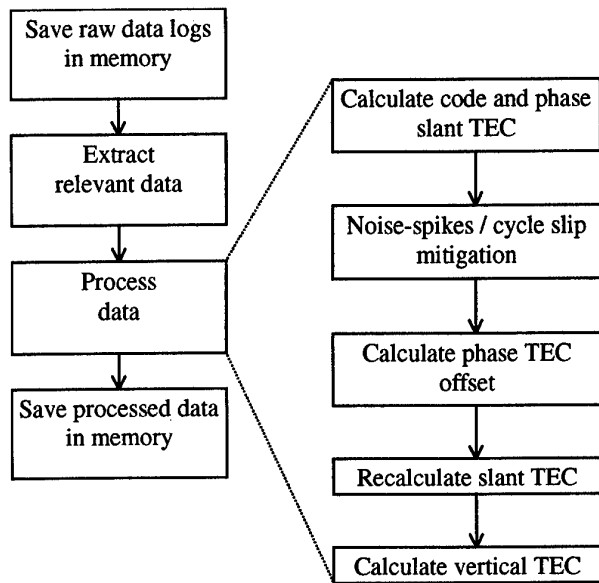

Figure 5 - Flow chart of main stages of TEC processing software

5.3.1 Data Extraction

The raw data logs RGEB and SATB contain TEC and satellite related information. To extract this information, these logs undergo error checking and an initial processing stage whereby upon identification of the type of log by reading the log header, if no errors are found, the remaining bytes in the message are read and placed into appropriate fields of a data structure. Error checking is necessary because of the possibility of recording corrupted logs. Two error checks are performed on the data. The first is to check the receiver status bits of the log, which should be equal to the number specified by the manufacturer for a good solution. The second test is the cyclic redundancy check. This check involves a cyclic 'exclusive or' of the bits in the log. The final result should be equal to zero for a valid log.

This extracted data can then be used for the necessary calculations mentioned above. It is important to note that the data structures containing this raw information are updated periodically, as the communication port receive buffer is flushed out. Therefore the data has to be processed immediately and stored in separate data structures which permanently reside in memory for the duration of the program. These structures hold information relevant to satellites over 24 hours where each satellite has its own data structure and it is possible to access information about any satellite for any time over this period.

5.3.2 Calculation of Slant TEC and Carrier Phase TEC

The following paragraphs refer to the theory outlined in Section 3. Using Equations (1), (2) and (3), the observed slant TEC can be calculated from either the pseudorange or the carrier phase data extracted from the RGEb log. Calculation of TEC using the pseudorange data yields values which are unambiguous but have a large absolute error. On the other hand calculation of TEC using the carrier phase information yields values which are much more precise but have an inherent phase ambiguity. It is desirable to produce TEC data that has the resolution of the phase measurements but with the phase ambiguity removed. This is achieved by using the method of least squares to fit the phase TEC to the code TEC and so calculate their relative offset.

The least squares fit analysis results in a simple expression for the offset:

$$\text{offset} = \frac{1}{N} \sum_i^N (\text{phase slant TEC}_i - \text{code slant TEC}_i) \quad (6)$$

For an ideal receiver and satellite, corrected slant TEC can now be calculated using the following expression:

$$\text{slant TEC} = \text{phase slant TEC} - \text{offset} \quad (7)$$

However, a further correction must be applied to the slant TEC. This correction is effectively a calibration constant correction for a given receiver-satellite link and it is added to take into account the delays introduced to the signal in the RF stages of the satellites and receiver. These delays introduce biases in the TEC data. Details on how the calibration constant is calculated can be found in Section 6. Thus, the general expression for the corrected slant TEC becomes:

$$\text{slant TEC} = \text{phase slant TEC} - \text{offset} + \text{calibration constant} \quad (8)$$

The carrier phase offset is calculated from a summation over all of the TEC data points available and hence must be calculated over the entire data set. This poses a problem as the data is collected in real time; at any given time there is not a complete data set for a given satellite pass. To overcome this problem the algorithm was implemented by recalculating the offset for each and every new data point that was added to the data set, and then updating all of the previous slant TEC data points for the given satellite pass (some satellites come into view more than once and it is important to calculate the offset separately for each pass). Thus, the offset calculation is an iterative process, the larger the data set the more precise the result.

5.3.3 Calculation of Vertical TEC

Vertical TEC is calculated from slant TEC using Equations (4) and (5) in Section 3. It can be seen that the calculation depends on the effective ionospheric height which is not accurately known and furthermore varies with time and geographic location. Thus, it is difficult to calculate an accurate value for the vertical TEC. A variable height is more appropriate but beyond the scope of the software package as it currently stands. This will be accounted for in subsequent off-line processing.

5.3.4 Noise Mitigation

Spikes, cycle-slips and other noise effects in the pseudo-range and carrier-phase data occur at low elevations and cause significant problems in the calculation of TEC for the real-time displays. The spikes in the data are typically due to the receiver momentarily losing lock on the satellite. Each time the receiver regains lock, a different phase ambiguity results. The problems caused by these noise effects are clearly evident from examination of Equation 6; spikes and cycle-slips in the raw data cause the least-squares fit of the carrier-phase data to the code data to be corrupted, yielding a bad estimate for the carrier-phase ambiguity and a poorly calibrated absolute TEC. It was therefore necessary to develop an algorithm to remove these effects from the data prior to the calculation of TEC.

The technique used to mitigate the effects of spikes, loss of lock and cycle-slips on the slant TEC derived from the carrier-phase was quite simple and is based upon the rate of change of the phase derived slant TEC. The algorithm developed to implement the technique calculates the derivative of phase slant TEC using a 3-point Lagrange method. The resultant derivative is then compared with a threshold value. If the derivative is less than the threshold, the data is retained for further processing otherwise the 3 points used to calculate

the derivative are discarded. The technique is computationally fast and simple to implement and thus is well suited for the real-time displays. However, for off-line processing, superior techniques are used to eliminate the effects of cycle-slips, multipath and other noise sources without affecting the system's response to phenomena such as scintillation.

5.4 Graphical User Interface

The graphical user interface (GUI) running on Windows 95 was developed using the facilities provided by Borland's Integrated Development Environment. In particular, the basic structure of the GUI was constructed using Borland's AppExpert, a package that generates the basic windows code required to create an application window with features depending on options selected by the programmer. Other features such as the menu and tool bars which allow operator control of the receiver, were implemented through Borland's Resource Workshop. These features were added to the GUI as the various receiver control functions were coded.

A desirable feature of the GUI is the display of data collected in real time. Whilst the TEC data displayed are only calibrated to first order, the purpose of the display is to provide an operator with feedback on how the data are behaving. The effort required to provide more accurate TEC values, incorporating accurate calibration constant and effective ionospheric height, is not warranted and is left to the post-processing stage.

The real time displays were implemented using a graphics package called Graphics Server. There are 3 real time displays, each of which update at an interval set by the operator, as follows: display of slant and vertical TEC together with the elevation of the satellites, display of satellites currently in view, and a display of satellite azimuth elevation tracks. Further, there is also a display of the free Jaz disk space. Figure 6, Figure 7 and Figure 8 illustrate these displays respectively.

TEC and azimuth track displays are available for each satellite. The TEC display time scale covers 24 hours in UT, where data recorded from 0UT up to and including the current UT is the current day's data, and from the current UT to 23:59UT is the previous day's data. Hence, as time progresses towards the end of the day, the old data is overwritten and replaced with the current day's data. The software ensures that at most the data is only a day old by initialising the data arrays appropriately.

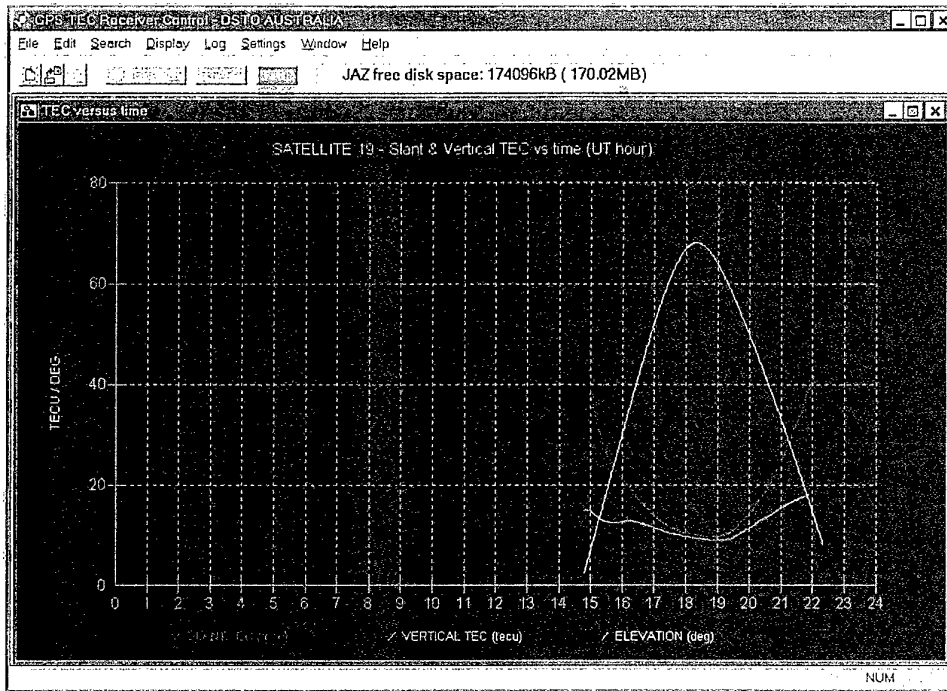

Figure 6 - Slant and Vertical TEC display

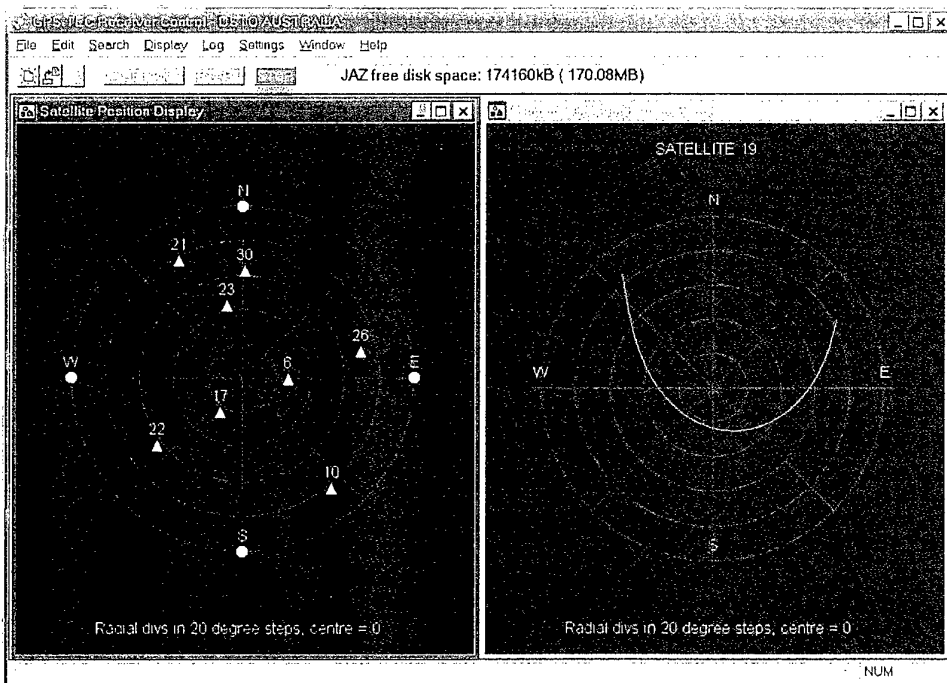

Figure 7 - Satellite Position display and Satellite Azimuth Elevation Track display

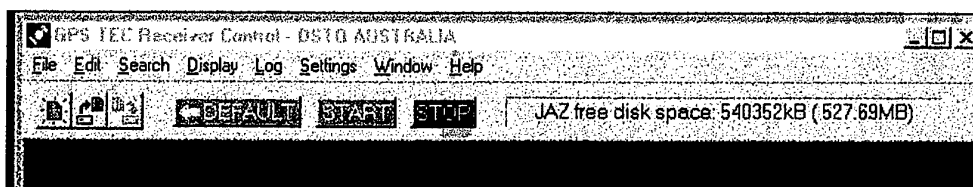

Figure 8 - Free Jaz Disk Space display

6. CALIBRATION OF THE TEC RECEIVERS

The total delay of a GPS signal as observed by a GPS receiver contains several terms. These are the dispersive ionospheric delay, non-dispersive tropospheric delay, non-dispersive delays due to system clocks, and dispersive RF delays in the RF stages of the transmitters and receivers. TEC estimation from GPS observations involves the measurement of the differential group delay between the two frequencies and therefore only the dispersive terms are required to be considered. For a given receiver-satellite link, the GPS measurement of the differential group delay is given by:

$$M = D_{TEC} + (S_{L2} - S_{L1}) + (R_{L2} - R_{L1}), \quad (9)$$

where M is the measured differential group delay, D_{TEC} is the differential delay due to the ionosphere, S_{L1} and S_{L2} are the satellite delays at L1 and L2, and R_{L1} and R_{L2} are the receiver delays. For brevity, the satellite and receiver differential group delays will from here on be referred to as the satellite and receiver biases.

In order to measure TEC with a dual frequency GPS receiver, it is necessary to calibrate the receiver to remove the satellite and receiver biases mentioned in the previous paragraph. There are several ways of estimating the total bias. The first and simplest is to relate the observed slant TEC, T_o , to an equivalent vertical TEC, T_v , by

$$T_o = T_v \cdot O(\theta) + B, \quad (10)$$

where $O(\theta)$ is the obliquity factor which is a function of the satellite elevation, and B is the bias (Davies and Hartmann, 1997). The obliquity factor is given by $O = 1 / \cos(\chi)$, where χ is the angle between the ray path and the vertical at the point where the ray path intersects the ionosphere which has been approximated by a thin shell at a height h_i . This point is referred to as the

Ionospheric Pierce Point (IPP). Figure 1 displays the geometry of the situation, with equation (5) giving the relation between obliquity and satellite elevation. The quantity $T_v \cdot O(\theta)$ is, of course, the slant TEC T_s . By making the relation between observed and vertical TEC in (10) we have assumed implicitly that the vertical TEC is constant. Thus, performing a linear least squares fit on the observed TEC and obliquity data yields an estimate of the bias, B .

The assumption of a constant vertical TEC requires that the least squares fit be performed on a relatively short time series (no more than say 30 minutes in duration) so that any temporal variations in TEC are small. Clearly it is essential that times during which dawn and dusk occur at the IPP are to be avoided. In addition there are underlying assumptions that there are no horizontal TEC gradients (or at least they are negligible), the ionosphere may be approximated by a thin shell, and an appropriate ionospheric height may be chosen. The thin shell approximation is probably valid for mid-latitude regions but definitely is not appropriate for the equatorial region. All of these assumptions severely limit the precision of the bias estimated by the constant vertical TEC least squares method. Davies and Hartmann (1997) report that because of these uncertainties the limit on the accuracy of GPS TEC is about 3 TECu.

The above method is used for an initial calibration of the SSD(WASD) GPS TEC receivers, the crude calibration obtained being sufficient for the real-time displays (described in Section 8). However, for the actual processing of TEC data at DSTO Salisbury, superior methods of TEC calibration will be required. Such methods include the Self Calibration Of pseudoRange Errors (SCORE) (Bishop et al., 1994, 1996) and a least squares estimation process using a two-dimensional model of TEC and performed in the co-rotating frame (Lanyi and Roth, 1988; Coco et al., 1991). The University of New South Wales under contract with SSD is also developing a technique which will remove multipath and biases in the satellites and receivers.

The data used for the calibration of the TEC receivers were recorded during 10 October 1997 at DSTO Salisbury (lat: -35). The thin shell ionospheric model should be valid at this latitude and a mean ionospheric height of 400km was used for the obliquity calculation. The data for all three co-located receivers were recorded simultaneously offering a consistency check of the obtained calibration values. Figure 9 displays the uncalibrated TEC data obtained from satellite PRN 3 and a correlation analysis between pairs of data sets yield correlation coefficients of 0.9999 for all three possible combinations. Thus, the quality of these data sets is high. The average difference in TEC between pairs of data sets is 20.03 TECu between Rxs 1 and 2, 9.31 TECu between Rxs 2 and 3,

and 10.72 TECu between Rxs 1 and 3. We require that the calculated calibration values are consistent with the differences between the receivers.

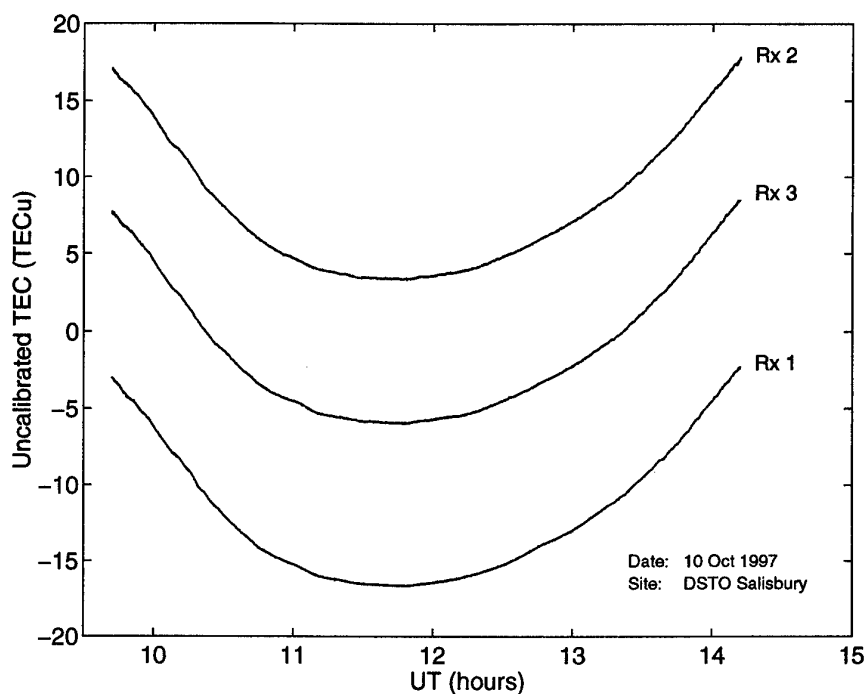

Figure 9 - Uncalibrated TEC calculated from PRN 3 for all three DSTO GPS TEC receivers. The data were recorded at DSTO Salisbury (lat: -35) during 10 Oct 1997.

TEC and satellite elevation and azimuth data from PRN 3 were available over approximately 5 hours on October 10 at a sampling period of 2 sec. Linear least squares fits to the observed TEC and calculated obliquity function were performed on 20 minute data segments (600 points) shifted by 1 minute for subsequent fits. Thus, about 300 estimates for the bias for each receiver were yielded. These bias estimates were then subjected to the following acceptance criteria: (1) The vertical TEC data obtained from the fit was required to be positive, and (2) The "goodness of fit" as measured by the χ^2 -statistic must be sufficiently small. For our purposes, a cut-off of 0.2 for the χ^2 -statistic yielded acceptable results. The acceptance criteria had the effect of rejecting bad fits which were probably due to the vertical TEC not being constant over the duration of the data used for the fits. Histograms of the accepted bias values were then plotted for each receiver and Gaussian curves fitted.

Figure 10 displays the histogram and fitted Gaussian for Rx 1. From this figure we note that the mean of the fitted Gaussian is -27.5 ± 1.6 TECu, and this value

is taken to be the bias for Rx 1. The error in the mean is the 95% confidence limit obtained from the fit procedure. At this point we note that this value will have to be revised as a non-standard setup for Rx 1 was used. With this particular setup an antenna cable which was longer than the standard cable was required, and this had the effect of increasing the RF delay and hence the bias. However, the other two receivers were set up in the standard manner so their biases are valid. The calibration data from Rx 1 is still useful from the point of view that it may be used to check for consistency between the receivers as described previously.

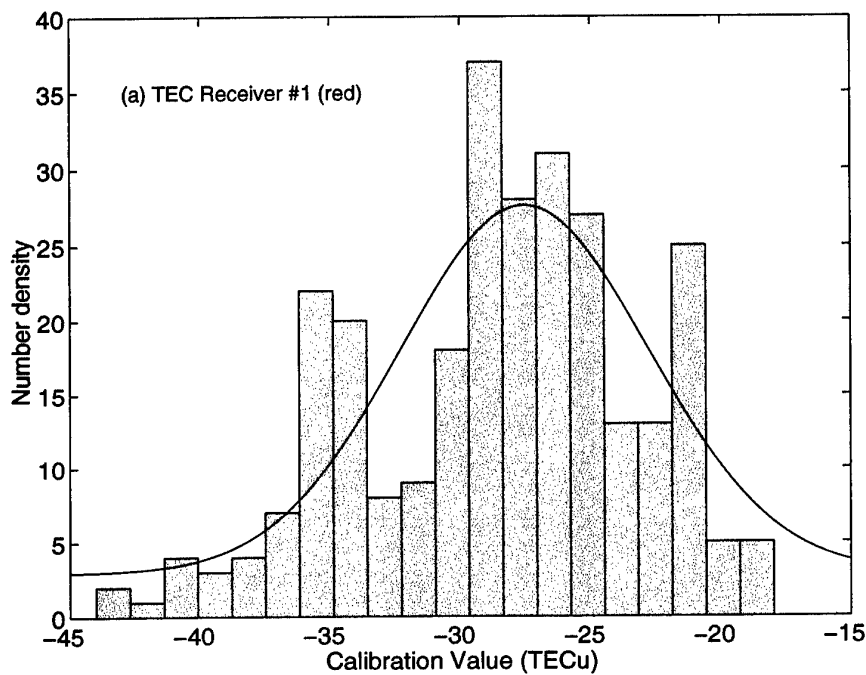

Figure 10 - Histogram of calibration values for Rx 1 calculated from the TEC data displayed in Figure 9. The solid line is a Gaussian curve fitted to the histogram and has a mean and standard deviation of -27.5 and 6.8 respectively.

The histograms of calibration data obtained from receivers 2 and 3 yielded bias estimates of -8.6 ± 1.4 TECu and -17.4 ± 2.0 TECu respectively. The difference between the biases for receivers 1 and 2 is 19.0 ± 3.0 TECu which is consistent with the uncalibrated TEC data displayed in Figure 9 (difference of 20.0 TECu between receivers). Similarly the differences between biases for receivers 2 and 3 (8.8 ± 3.4) and for receivers 1 and 3 (10.1 ± 3.6) are also consistent with the uncalibrated TEC data.

As noted previously, these calibration values are first order estimates which are employed only for the real time display of the TEC system. Indeed only a single calibration value is determined for each receiver, no attempt has been made to derive calibration values for each satellite. Superior techniques will be used to yield more precise calibration values for the recorded raw data and these will be applied to data obtained from each satellite separately. Results will be described elsewhere.

7. CONCLUSION

A system based on a NovAtel MiLLennium™ L1/L2 dual frequency Global Positioning System (GPS) satellite receiver has been developed to monitor ionospheric Total Electron Content (TEC) and to detect ionospheric scintillation.

Software has been written in the C++ language for hosting on a Notebook computer to control the logging of data from the receiver to an Iomega Jaz 1 Gbyte removable disk unit. Real time displays on the Notebook screen permit the inspection of both slant and vertical TEC values taken over the preceding 24 hours, together with the locations of satellites currently in view. The TEC data have been calibrated to first order with respect to system delay bias, ambiguity resolution and multipath rejection. The system is suitable both for long term unattended routine data gathering and for more intensive short term campaigns.

Two receiver system units were deployed, one each in Indonesia and Malaysia in December 1997 for the purpose of monitoring the effects of the equatorial ionosphere on GPS navigation performance as the current solar cycle approaches its 11 year maximum in activity. They have been operating successfully through a variety of environmental conditions, including equatorial scintillation events, geomagnetic storms and an annular solar eclipse. Reports of the data analysis will be presented elsewhere.

References

Ackroyd, N, and Lorimer, R, "A GPS User's Guide", Lloyd's of London Press, 1990

Bishop, G, Walsh, D, Daly, P, Mazzella, A, and Holland, E, "Analysis of the temporal stability of GPS and GLONASS group delay correction terms seen in various sets of Ionospheric delay data", proceedings ION GPS-94, The Institute of Navigation, Washington D. C., 1653-1661, 1994.

Bishop, G, Mazzella, A, Rao, S, Batchelor, A, Flemming, P, Lunt, N, Kersley, L, "Validations of the SCORE Process", Navigation and Positioning in the Information Age, proceedings of the National Technical Meeting, Institute of Navigation 1997, Alexandria, 289 - 296, 1997.

Coco, D, "GPS - Satellites of Opportunity for Ionospheric Monitoring", GPS World, page 47, 1991

CoCo, D S, Coker, C, Dahlke, S R, Clynych, J R, "Variability of GPS satellite differential group delay biases", IEEE Trans. Aerospace and Electronic Systems, 27, 931-938, 1991.

Davies, K, and Hartmann, G K, "Studying the ionosphere with the Global Positioning System", Radio Science, 32, 1696-1703, 1997.

Millikan, R J, and Zoller, C J, "Principle of operation of NAVSTAR and system characteristics", Global Positioning System - Papers published in NAVIGATION, The Institute of Navigation, 1, 1980.

Ho, C M, Mannucci, A J, Lindqwister, U J, Pi, X, and Tsurutani, B T, "Global ionosphere perturbations monitored by the worldwide GPS network", Geophys Res Lett, vol 23, no 22, pages 3219-3222, 1996

Klobuchar, J A, "Ionospheric Effects on GPS", in "Global Positioning System: Theory and Applications, Vol 2", edited by Parkinson, B W and Spilker, J J, Progress in Astronautics and Aeronautics, Vol 164, page 485, 1996

Knight, M F, Finn, A, and Cervera, M A, "Ionospheric effects on global positioning system receivers", DSTO Technical Report No. DSTO-RR-0121, 1998.

Lanyi, G E, and Roth, T, "A comparison of mapped and measured total ionospheric electron content using global positioning system and beacon satellite observations", Radio Science, 23, 483-492, 1988.

Sonnenberg, S, "Radio and Electronic Navigation", Chapter 7, Butterworth and Co, 6th Edition, 1988

Wanninger, L, "Effects of the Equatorial Ionosphere on GPS", GPS World, page 48, July 1993

Van Dierendonck, A J, Klobuchar, J, and Hua, Q, "Ionospheric scintillation monitoring using commercial single frequency C/A code receivers", Proc ION GPS-93, Sixth International Technical Meeting of the Satellite Division of the Institute of Navigation, Salt Lake City, Utah, 1993.

DISTRIBUTION LIST

A Global Positioning System Receiver for
Monitoring Ionospheric Total Electron Content

Kyriaky Eftaxiadis, Dr Manuel A. Cervera, Dr Richard M. Thomas

AUSTRALIA

DEFENCE ORGANISATION

Task Sponsor

S&T Program

Chief Defence Scientist
FAS Science Policy
AS Science Corporate Management
Director General Science Policy Development
Counsellor Defence Science, London (Doc Data Sheet)
Counsellor Defence Science, Washington (Doc Data Sheet)
Scientific Adviser to MRDC Thailand (Doc Data Sheet)
Scientific Adviser Policy and Command
Navy Scientific Adviser (Doc Data Sheet and distribution list only)
Scientific Adviser - Army (Doc Data Sheet and distribution list only)
Air Force Scientific Adviser
Director Trials
DST-SEA Dr Hugh Barkley

} shared copy

Aeronautical and Maritime Research Laboratory

Director

Electronics and Surveillance Research Laboratory

Director (1 copy)

Chief of Surveillance Systems Division (SSD)

Research Leader(s) (SSD): Dr Jackie Craig
Dr Bruce Ward

Head Electromagnetics and Propagation (SSD)

Head Surface Positioning Systems (SSD)

Dr Anthony Finn (SSD)

Dr Dan Meehan (SSD)

Dr Rod Barnes (SSD)

Dr Fred Earl (SSD)

Author(s): Kyriaky Eftaxiadis (3 copies)

Dr Manuel Cervera (3 copies)

Dr Richard Thomas (3 copies)

DSTO Library

Library Fishermens Bend

Library Maribyrnong

Library Salisbury (2 copies)
Australian Archives
Library, MOD, Pyrmont (Doc Data sheet only)

Capability Development Division

Director General Maritime Development (Doc Data Sheet only)
Director General Land Development (Doc Data Sheet only)
Director General C3I Development (Doc Data Sheet only)
Director General (Aerospace) Development (Doc Data Sheet only)

Army

ABCA Office, G-1-34, Russell Offices, Canberra (4 copies)
SO (Science), DJFHQ(L), MILPO Enoggera, Queensland 4051 (Doc Data Sheet only)
NAPOC QWG Engineer NBCD c/- DENGERS-A, HQ Engineer Centre Liverpool Military Area, NSW 2174 (Doc Data Sheet only)

Intelligence Program

DGSTA Defence Intelligence Organisation

Corporate Support Program (libraries)

OIC TRS, Defence Regional Library, Canberra
*US Defense Technical Information Center, 2 copies
*UK Defence Research Information Centre, 2 copies
*Canada Defence Scientific Information Service, 1 copy
*NZ Defence Information Centre, 1 copy
National Library of Australia, 1 copy

UNIVERSITIES AND COLLEGES

Australian Defence Force Academy
Library
Head of Aerospace and Mechanical Engineering
Deakin University, Serials Section (M list), Deakin University Library, Geelong, 3217
Senior Librarian, Hargrave Library, Monash University
Librarian, Flinders University

OTHER ORGANISATIONS

NASA (Canberra)
AGPS
State Library of South Australia
Parliamentary Library, South Australia

OUTSIDE AUSTRALIA

ABSTRACTING AND INFORMATION ORGANISATIONS

Library, Chemical Abstracts Reference Service
Engineering Societies Library, US
Materials Information, Cambridge Scientific Abstracts, US

Documents Librarian, The Center for Research Libraries, US

INFORMATION EXCHANGE AGREEMENT PARTNERS

Acquisitions Unit, Science Reference and Information Service, UK

Library - Exchange Desk, National Institute of Standards and Technology, US

SPARES (5 copies)

Total number of copies: 63 (including spares)

DEFENCE SCIENCE AND TECHNOLOGY ORGANISATION DOCUMENT CONTROL DATA				1. PRIVACY MARKING/CAVEAT (OF DOCUMENT)			
				2. TITLE A Global Positioning System Receiver for Monitoring Ionospheric Total Electron Content		3. SECURITY CLASSIFICATION (FOR UNCLASSIFIED REPORTS THAT ARE LIMITED RELEASE USE (L) NEXT TO DOCUMENT CLASSIFICATION) Document (U) Title (U) Abstract (U)	
4. AUTHOR(S) Kyriaky Eftaxiadis, Dr Manuel A. Cervera, Dr Richard M. Thomas			5. CORPORATE AUTHOR Electronics and Surveillance Research Laboratory PO Box 1500 Salisbury SA 5108 Australia				
6a. DSTO NUMBER DSTO-TR-0742		6b. AR NUMBER AR-010-671		6c. TYPE OF REPORT Technical Report		7. DOCUMENT DATE April 1999	
8. FILE NUMBER B9505-17-59	9. TASK NUMBER ADA 96/005		10. TASK SPONSOR DASD		11. NO. OF PAGES 27		12. NO. OF REFERENCES 14
13. DOWNGRADING/DELIMITING INSTRUCTIONS To be reviewed three years after date of publication			14. RELEASE AUTHORITY Chief, Surveillance Systems Division				
15. SECONDARY RELEASE STATEMENT OF THIS DOCUMENT <i>Approved for public release</i>							
OVERSEAS ENQUIRIES OUTSIDE STATED LIMITATIONS SHOULD BE REFERRED THROUGH DOCUMENT EXCHANGE CENTRE, DIS NETWORK OFFICE, DEPT OF DEFENCE, CAMPBELL PARK OFFICES, CANBERRA ACT 2600							
16. DELIBERATE ANNOUNCEMENT No Limitations							
17. CASUAL ANNOUNCEMENT Yes							
18. DEFTEST DESCRIPTORS Global Positioning System Ionospheric Scintillations Electron Density (concentration)							
19. ABSTRACT A system based on a NovAtel MiLLennium L1/L2 dual frequency Global Positioning System (GPS) satellite receiver has been developed to monitor ionospheric Total Electron Content (TEC) and to detect ionospheric scintillation. Software has been written to control the logging of data from the receiver to an Iomega Jaz 1 Gbyte removable disk unit. Real time displays on the Notebook screen permit the inspection of both slant and vertical TEC values taken over the preceding 24 hours, together with the locations of satellites currently in view. The system is suitable both for long term unattended routine data gathering and for more intensive short term campaigns. Two receiver system units have been deployed in Indonesia and Malaysia for the purpose of monitoring the effects of the equatorial ionosphere on GPS navigation performance as the current solar cycle approaches its 11 year maximum in activity.							