

INTERNET DOCUMENT INFORMATION FORM

A . Report Title: An Inclined-Plate Technique for Increasing the Settling Rate of Fine-Grained Sediments in Hopper Bins

B. DATE Report Downloaded From the Internet: 07/06/99

C. Report's Point of Contact: (Name, Organization, Address, Office Symbol, & Ph #):
Dredging Operations Technical Support
Attn: Dr. Engler (601) 634-3624
3909 Halls Ferry Road
Vicksburg, MS 39180-6133

D. Currently Applicable Classification Level: Unclassified

E. Distribution Statement A: Approved for Public Release

F. The foregoing information was compiled and provided by:
DTIC-OCA, Initials: VM Preparation Date 07/06/99

The foregoing information should exactly correspond to the Title, Report Number, and the Date on the accompanying report document. If there are mismatches, or other questions, contact the above OCA Representative for resolution.



Dredging Research Technical Notes



An Inclined-Plate Technique for Increasing the Settling Rate of Fine-Grained Sediments in Hopper Bins

Purpose

The purpose of this technical note is to provide information on a technique that may increase the effective load of hopper dredges and scows. Although laboratory tests of this method revealed that the inclined plate technique may not be practical for full-scale prototype application, it appears suitable for small-scale specialty dredging applications and for clarifying effluent from confined disposal areas.

Background

Hopper dredges frequently operate in an overflow mode to increase the solids load of the hopper. Typically, coarse sediments such as sands, rock, and gravel settle out of the suspension quickly, while the fine sediments such as silts and clays stay in suspension and tend to flow out of the hopper with the water. For mixed sediment loads with a high percentage of fine materials in suspension, overflowing the hopper may return a large fraction of sediment to the project area without appreciably increasing the hopper load. This results in a hopper load with a low solids content. Dredging operations costs can be increased by the extra trips to the disposal, or placement, site resulting from low solids content. Effective methods to increase the settling rate of these fine sediments would result in increased solids load in the hopper, reduced transport costs, and an increase in the fraction of dredged material going to disposal sites.

This technical note describes laboratory tests conducted to investigate the use of inclined plates in hopper bins for increasing the settling rate of fine-grained sediments. The inclined plate technique was one of several methods investigated under the Dredging Research Program (DRP) for increasing the solids load in dredge hoppers. The test facilities and procedures are described, as well as the results.

Additional Information or Questions

Contact the author, Mr. Stephen H. Scott, (601) 634-4286, or the manager of the Dredging Research Program, Mr. E. Clark McNair, Jr., (601) 634-2070.

Introduction

Tests were conducted to investigate the effect of inclined baffle plates in a model hopper bin on the loading rate of fine-grained sediments. This settling phenomenon, referred to as the Lamella or Boycott Effect, accelerates the separation of suspended solids from the liquid media by creating a density gradient within the slurry by which the less dense water is transported along the inclined plates to the surface of the hopper. As the clarified water flows upward toward the surface, the higher density solids-laden water flows to the bottom of the hopper.

Theory of Operation for Inclined-Plate Settlers

The phenomena of the settling of a suspension between inclined plates was investigated by, among others, Zahavi and Rubin (1975) at the Israel Institute of Technology. They determined that the settling rate of the suspension was influenced by two factors--the settling rate due to the effect of gravity on the suspended particles and the settling rate due to the presence of an inclined surface. Medical workers were among the first to observe the enhanced settling due to inclined surfaces. They noted that the settling rate of red blood cells in test tubes was increased by tilting the test tubes at an angle.

Zahavi and Rubin studied the effect of the inclined plates by injecting dye into the suspension between the plates. The studies indicated that a thin clear water layer immediately forms under the plates with clear water initially rising slowly between the particles in suspension. At any given horizontal plane in the settler, a pressure differential exists between the higher density suspension and the clarified water layer under the plate. This pressure gradient drives the clear water flow out of the suspension and along the underside of the plates at a high flow rate, thus increasing the settling rate. The high velocity of this flow entrains some of the sediment particles along the boundary of the suspension and clear water layer, resulting in a mixing effect and a lower separation efficiency. Studies also indicate that an increase in the suspension concentration resulted in a decrease in the clear liquid flow through the suspension, indicating a decreased settling rate. By increasing the suspension concentration above a certain value, the fluid flow around sediment particles is restricted and causes a hindered settling effect.

Model Hopper Test Facility

A model hopper facility was constructed, consisting of a model hopper, mixing tank, and an overflow catch basin (Figures 1, 2, and 3). The model hopper had a volume of approximately 0.7 cu m, and the mixing tank had a capacity of about 2.8 cu m. The model hopper was fitted with a slotted carriage for use in holding the inclined plates (Figure 4). Because of limited space in the hopper, the lengths of the plates were varied to accommodate the horizontal diffuser that was used to input the slurry into the hopper. The plate lengths varied from 15 to 71 cm, with the longest plates located in the back of the hopper, away from the diffuser. The diffuser was designed to reduce the turbulence of feed into the model hopper (Figure 5). Although not a standard method of introducing slurry into a hopper, the diffuser was used in these tests to provide an improved settling environment in the model hopper to determine the maximum efficiency of the inclined plates. The test facility had the capability of measuring the total hopper load with time, as well as vertical profiles of suspension density in the hopper. The hopper was suspended from a load cell which was capable of recording the hopper weight as a function of time. Density samples were taken as a vertical profile every 15 cm in the hopper. The overflow density was sampled by attaching a funnel on the top edge of the hopper, between the longest plates in the hopper (71 cm plate length). Samples of the overflow were collected in 100-mL bottles and analyzed with a digital hand-held density meter.

The model hopper tests described in this note were conducted with both silt and clay slurries. The clay was a commercially available kaolinite with a mean particle size of about 2 μm . The silt material was a naturally occurring

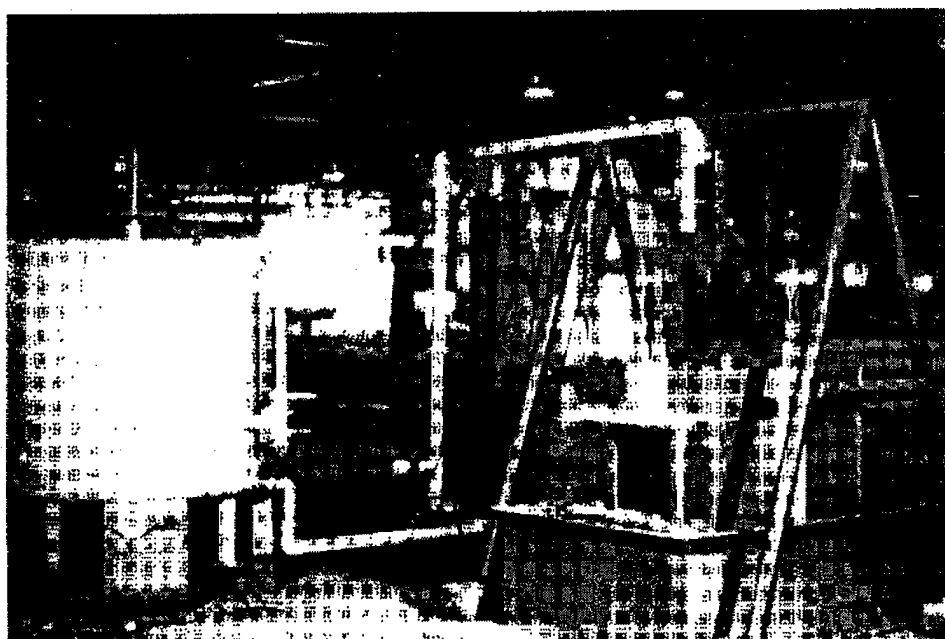

Figure 1. Model hopper overflow test facility

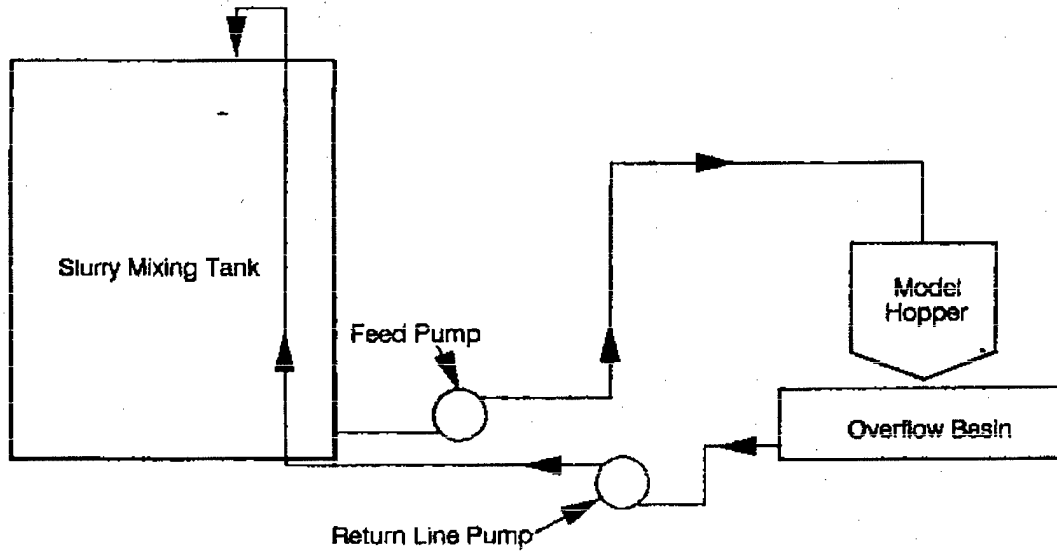

Figure 2. Model hopper overflow test loop

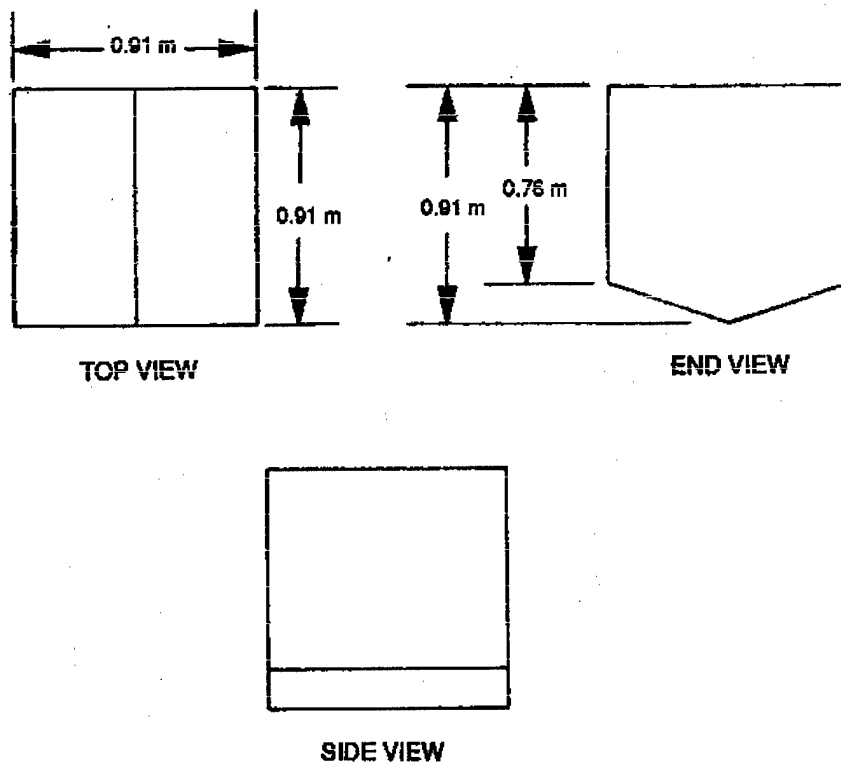

Figure 3. Model hopper dimensions

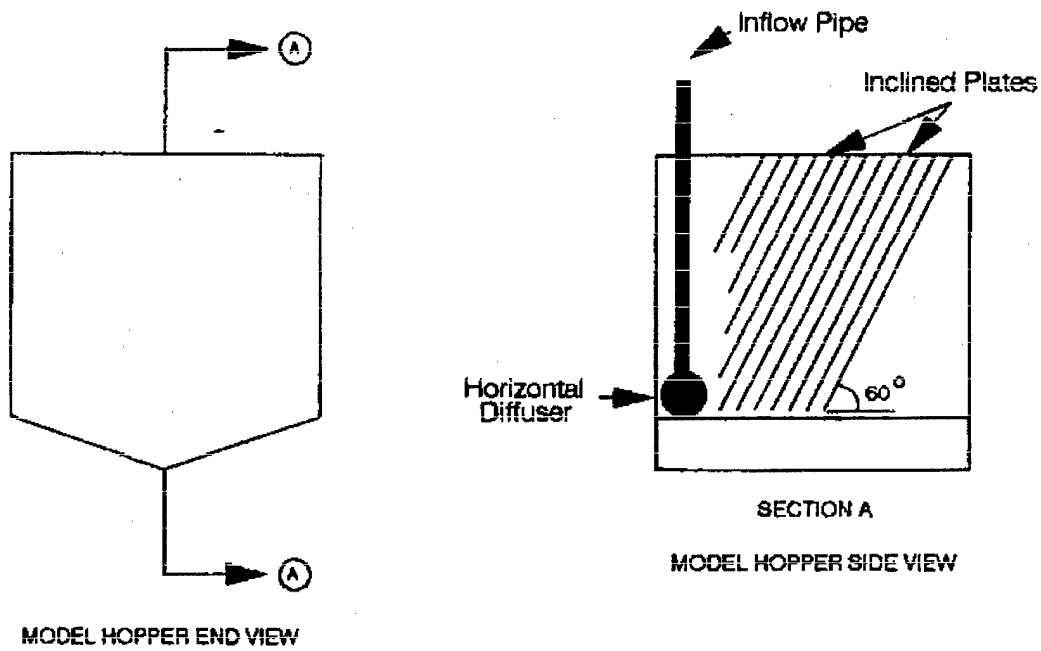

Figure 4. Approximate plate configuration in the hopper, section view

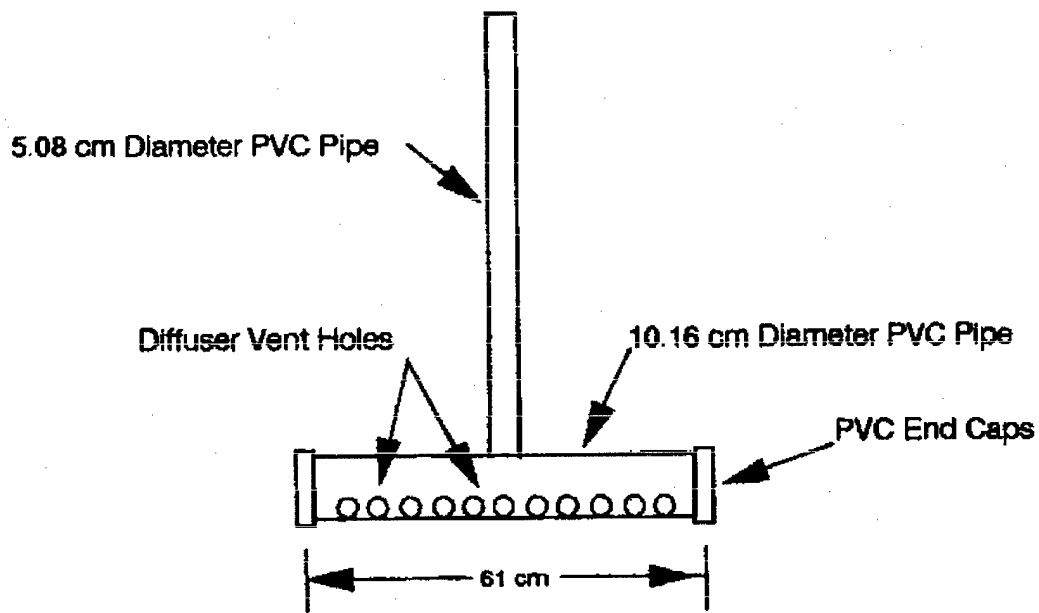

Figure 5. Horizontal diffuser design

sediment that was passed through a No. 200 mesh sieve to remove the sands. The naturally occurring clay fraction of the silt material was essentially removed by suspending the material in water and draining off the suspended clays. Particle size analysis was performed on the silt using standard pipette and electronic particle sizing methods. The median particle size range was 12 to 17 μm , indicating a fine to medium silt. The characteristic settling velocity was determined to be 0.020 cm/sec at a bulk wet sediment density of both 1.045 and 1.090 g/cu cm. This range of density is representative of slurry densities commonly overflowed from hopper dredges. The inclined-plate tests were conducted at these slurry densities.

A typical test began by mixing the slurry to the desired density. The slurry was then pumped through a 5.08-cm-diameter polyvinyl chloride (PVC) pipeline into the model hopper. A ball valve was used to provide a coarse adjustment for the flow rate. The actual discharge into the hopper was obtained by recording the time it took to fill the hopper. The slurry flowed up between the plates and was allowed to overflow for a specific period of time during which load cell data and overflow density samples were taken at various time intervals.

Test Results and Discussion

Clay Slurry Tests

To investigate the effects of inclined plates on the settling rate of a clay slurry, six inclined plates were placed in the model hopper (Figure 6). The plates were inclined 30 deg from the vertical, with 10-cm spacings between the plates. The plate lengths were 71 cm. Overflow tests were conducted at hopper fill rates of about 0.064 to 1.0 cm/sec. The hopper fill rate is the rate that the slurry rises up vertically in the hopper. This range of fill rates is approximately representative of prototype conditions. The rate is calculated by the following equation:

$$V_{\text{fill}} = \frac{Q_i}{A_h}$$

where

V_{fill} = the vertical fill rate, cm/sec

Q_i = the discharge into the hopper, cu cm/sec

A_h = the cross-sectional area of the hopper, sq cm

Although the load cell did not indicate any load gain in the hopper, a visual inspection of the overflow indicated that liquid-solid separation was taking place.

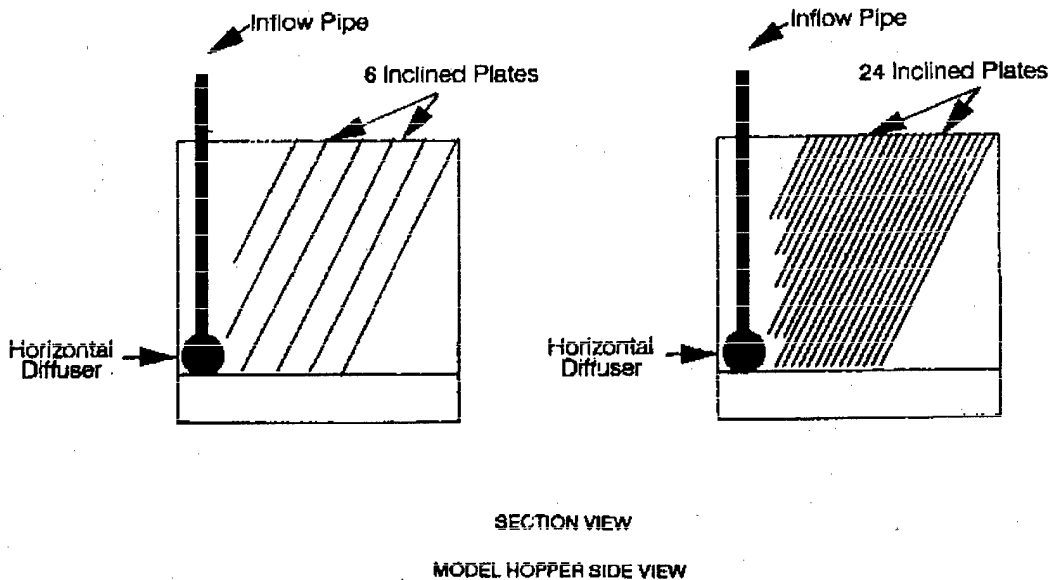

Figure 6. Approximate plate configuration for the clay slurry tests

Further tests were conducted with 24 inclined plates in the hopper (Figure 6). This plate arrangement resulted in a plate spacing of one plate per 2.54 cm. Density samples taken during these tests indicated that at the low hopper fill rate (0.064 cm/sec), up to 15 percent of the feed solids were being retained in the hopper during overflow. At a higher range of fill rates, around 0.25 to 1.0 cm/sec, the density samples indicated that no feed solids were accumulating in the hopper.

The data from the load cell were erratic during these initial tests. The stated accuracy of the load cell is 1 percent of full scale, or plus or minus 9 kg for test purposes. Because of the insensitivity of the load cell, only the density of the hopper overflow was sampled in subsequent tests. By recording the density of the overflow as a function of time, a mass balance was performed on the hopper to determine the amount of feed solids retained during overflow.

Mass Balance Calculations

Assuming that the flow rate into the hopper is the same as the overflow rate, the mass retained in the hopper per unit time $M(t)$ in grams is

$$M(t) = \left(\frac{BWD_f - BWD_o}{d_m - d_w} \right) \times d_m \times Q$$

where

- Q = volumetric flow rate, cu cm/sec
- d_m = density of silt, g/cu cm
- d_w = density of the water g/cu cm
- BWD_f = bulk wet density of the feed, g/cu cm
- BWD_o = bulk wet density of the overflow, g/cu cm

The data were analyzed for an overflow time of 200 sec. The total feed solids mass available to the hopper during the 200-sec overflow period would therefore be

$$M_t = M(t) \left(\frac{BWD_f - d_w}{BWD_f - BWD_o} \right) \times 200$$

The efficiency of the inclined plates in settling out the solids in suspension was determined by calculating the percent of feed solids retained in the hopper during overflow. This percent is the feed solids mass retained in the hopper divided by the total feed solids mass input into the hopper during the overflow period. The feed solids mass retained was calculated by incrementally summing the overflow density versus time data generated from the laboratory tests. For overflow density samples $d_0, d_1, d_2, \dots, d_n$ (where d_n equals the density of the last sample) taken at times $t_0, t_1, t_2, \dots, t_n$ (where t_n equals 200 sec, the time of the last sample taken), the average overflow bulk wet density per sample interval is calculated by

$$BWD_{avg} = \frac{BWD_{oi+1} + BWD_{oi}}{2}$$

where

$$i = 0, 1, 2, \dots, n-1$$

The total feed solids retained during the overflow cycle, M_r , would then be described by

$$M_r = \sum_{i=0}^{n-1} \left[\left(\frac{BWD_f - BWD_{avg}}{d_m - d_w} \right) \times d_m \times Q \times (t_{i+1} - t_i) \right]$$

This equation represents the total inflow solids mass accumulated in the hopper over a 200-sec overflow cycle. The percentage of feed solids retained in the hopper would therefore be calculated by

$$P_r = \frac{M_r}{M_t}$$

Silt Slurry Tests

Silt slurry tests were conducted with and without plates in the model hopper. Tests were conducted without plates for baseline data on the settling rate of the suspended sediments due to the effect of gravity. Tests were

conducted for both 24- and 12-plate arrangements. The 24-plate arrangement had a plate spacing of one plate per 2.54 cm, while the 12-plate arrangement had a plate spacing of one plate per 5.08 cm. The hopper fill rates were varied within the range of about 0.064 to 1.0 cm/sec. The overflow was sampled between the 71-cm length plates located in the back of the hopper. The following test description and results are based on flow through the 71-cm plates.

Figures 7 and 8 describe the results of the silt slurry overflow tests. Tests were conducted at slurry densities of 1.045 and 1.090 g/cu cm to determine the effect of concentration on plate performance. Figure 7 describes the density of the overflow at equilibrium as a function of hopper fill rate for both the baseline conditions of no plates in the hopper and conditions of 12 and 24 plates in the hopper. The overflow density at equilibrium is the overflow density reached after a model hopper overflow duration of 200 sec. Only the 24-plate arrangement was tested with the 1.090 g/cu cm density slurry. Figure 8 shows the percent of solids retained in the hopper as a function of the hopper fill rate. These plots were also generated for a 200-sec model hopper overflow time.

Figure 7 clearly shows that the plates are effective in lowering the overflow density, thus increasing the solids retained in the hopper. Figure 7 indicates that the efficiency of the plates increases with hopper fill rates greater than 0.25 cm/sec, becoming constant at about 0.50 cm/sec. This efficiency is defined by the change in density that occurs between the curves representing conditions of no plates and 24 or 12 plates in the hopper.

The plots of percent solids retained as a function of hopper fill rate (Figure 8) indicate that, for the 1.045 g/cu cm feed density, the 24-plate arrangement with 2.54-cm plate spacings resulted in 50 percent more feed solids retained than for the case of no plates in the hopper. The 12-plate arrangement with 5.08-cm plate spacings resulted in about 25 percent more feed solids retained. This percentage increase was constant for hopper fill rates of about 0.50 to 1.0 cm/sec. With an increase in feed density to 1.09 g/cu cm, the 24-plate arrangement resulted in about a 30 percent increase in feed solids retained in the hopper. This percentage increase was constant for hopper fill rates of about 0.50 to 0.80 cm/sec.

The above-mentioned results are based on all of the slurry passing between the plates with the maximum length of 71 cm. In prototype applications, a portion of the flow would not pass between plates because of space limitations in the hopper. This would result in a reduced solids retention efficiency in the hopper.

The inclined plates in the model hopper only occupied a small portion of the available volume, but added substantial weight to the hopper. For a practical application, it would be necessary to fabricate the plates out of low-density plastics or composite materials, such as graphite-epoxy, that possess the strength and abrasion-resistance properties to survive in a dredge hopper environment.

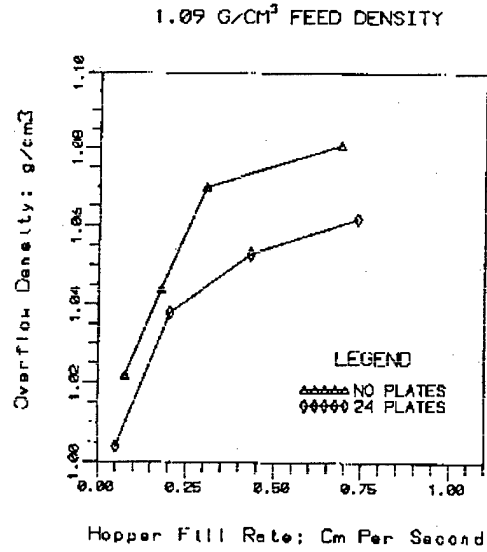
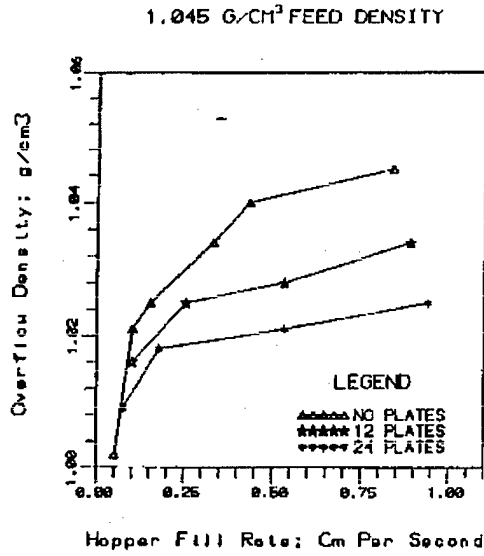

Figure 7. Overflow density at equilibrium for a 200-sec overflow duration

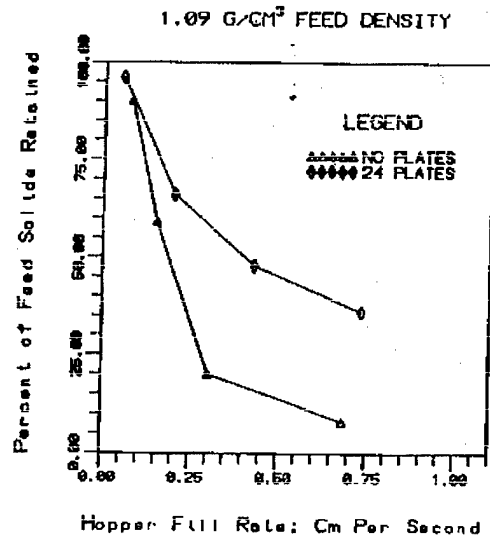
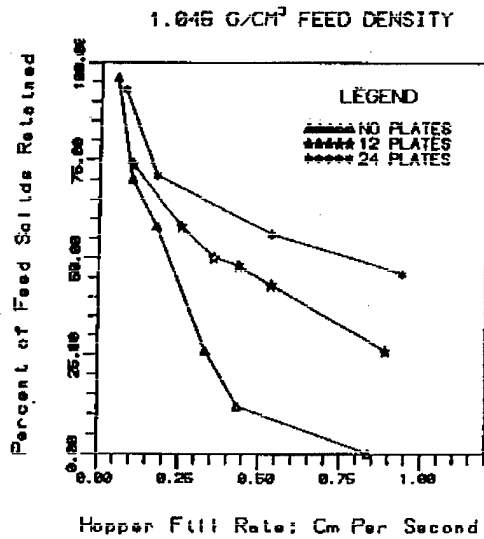

Figure 8. Percent of feed solids retained for a 200-sec overflow duration

By increasing the solids content of the slurry by a factor of two, the percent of feed solids retained in the hopper was reduced from 50 to 30 percent. Because of this decrease in plate efficiency with increasing concentration, the inclined-plate concept with this configuration may only be viable for low-density slurries (< 1.1 g/cu cm).

The model hopper inclined-plate arrangement can be approximately scaled to prototype. Because the settling rate of the suspended sediments due to gravity is constant in the model and the prototype and the settling rate due to the inclined plates is constant per unit plate area, then the model should scale to prototype by the ratio of the suspension height between the plates to the plate spacing in the hopper, excluding mixing effects due to turbulent flow conditions in the hopper. For the model hopper with 71-cm plates at a 30-deg angle (61-cm suspension height) and a 2.54-cm plate spacing this ratio would be 61/2.54, or about 24. Therefore, the prototype plate arrangement can be described by the following equation

$$\frac{\text{Suspension Height}}{\text{Plate Spacing}} = 24$$

For example, for a prototype hopper with the dimensions of 12-m width and 12-m depth, the suspension height for 12-m length plates at a plate angle of 30 deg from the vertical would be about 10 m. An estimate of the correct plate spacing for scaling the model to prototype would then be 10/24, or 0.42 m apart. This scaling relationship represents an estimate of the plate configuration required, with the actual plate spacing requirements not yet determined exactly.

Conclusions

The following conclusions are based on test results:

1. For clay suspensions, an inclined plate spacing of one plate per 2.54 cm in the hopper increased the percent of feed solids retained in the hopper by only about 15 percent at an impractical low hopper fill rate of 0.064 cm/sec.
2. Test results indicate that the efficiency of inclined plates decreases with increased slurry density, increases with decreased plate separation, and increases with decreased flow rate.
3. The plates are more efficient at the higher hopper fill rates (0.25 cm/sec) for the silt slurry than for the clay slurry.
4. For hopper fill rates in the range of 0.25 to 1.0 cm/sec with a 1.045 g/cu cm silt slurry and an inclined-plate spacing of one plate per 2.54 cm, 50 percent of the feed solids were retained in the model hopper over a 200-sec overflow period. By doubling the plate spacing to 5.08 cm, the

percent solids mass retained drops to about 25 percent, or approximately one-half.

5. When the silt slurry density was increased from 1.045 to 1.090 g/cu cm, a 20 percent reduction in the solids retained in the hopper occurred over a 200-sec overflow time for a plate spacing of one plate per 2.54 cm in the hopper.

6. At the one plate per 2.54-cm spacing in the model, the plates occupy very little volume, but the total weight added to the hopper is substantial.

The laboratory tests of the inclined-plate concept revealed initial design parameters for developing large-scale inclined plate settlers. Although the technique has limited potential for prototype hopper dredge application, it may be applicable to inland disposal operations which require that suspended solids be removed from confined disposal site effluent. The use of inclined plates in settling basins would reduce the settling basin surface area requirement, resulting in a more space efficient batch settling operation.

Reference

Zahavi, Eli, and Rubin, Eliezer. 1975. "Settling of Solid Suspensions Under and Between Inclined Surfaces," *Industrial and Engineering Chemistry, Process Design and Development*, Vol 14, No. 1, pp 34-44.