

## INTERNET DOCUMENT INFORMATION FORM

**A . Report Title: Fluidizer System Design for Channel Maintenance and Sand Bypassing**

**B. DATE Report Downloaded From the Internet: 07/06/99**

**C. Report's Point of Contact: (Name, Organization, Address, Office Symbol, & Ph #):**  
Dredging Operations Technical Support  
Attn: Dr. Engler (601) 634-3624  
3909 Halls Ferry Road  
Vicksburg, MS 39180-6133

**D. Currently Applicable Classification Level: Unclassified**

**E. Distribution Statement A: Approved for Public Release**

**F. The foregoing information was compiled and provided by:**  
DTIC-OCA, Initials: VM Preparation Date 07/06/99

The foregoing information should exactly correspond to the Title, Report Number, and the Date on the accompanying report document. If there are mismatches, or other questions, contact the above OCA Representative for resolution.

19990712 067



# Dredging Research Technical Notes



## Fluidizer System Design for Channel Maintenance and Sand Bypassing

### Purpose

This technical note summarizes the design procedure given by Weisman and Lennon (in preparation) for fluidizer systems to be used in channel maintenance and sand bypassing. Weisman and Lennon (1992) provides similar, but less up-to-date information. The main emphasis of this technical note is on design of the fluidizer pipe itself with suggestions concerning other aspects of the system.

### Background

Fluidization is a process in which fluid is injected into a granular medium (typically sand) causing the grains to lift and separate. Historically, applications of fluidization have been in chemical and sanitary engineering for combustion processes, mass and heat exchange, and backwashing of sand filters. Over the last decade, research on fluidization of sand at tidal inlets and harbor mouths has been undertaken to use fluidization for maintenance of navigable waterways and for use in sand bypassing.

The design objective for a fluidization system is primarily to create a trench of a given cross-section and length. To obtain a trench, complete fluidization must be achieved. The two basic parts of the design are the hydraulic aspect to attain full fluidization and a geometric element to obtain a desired trench geometry. Basic research over the past decade has helped define these two crucial aspects.

### Additional Information

For additional information, contact Mr. James E. Clausner, (601) 634-2009, or the manager of the Dredging Research Program, Mr. E. Clark McNair, Jr., (601) 634-2070.

DISTRIBUTION STATEMENT A  
Approved for Public Release  
Distribution Unlimited

19990712 047

## Fluidization Phenomena

For bypassing applications, water is pumped into a perforated pipe buried beneath the sand. Initially water is pumped into the pipe and exits from the perforations at a low flow rate that does not disrupt the fixed bed (Figure 1a). For the relatively small sand sizes normally found near tidal inlets (mean diameter 0.5 mm or less), the velocity through the sand will be low enough that Darcy type (laminar) flow will occur up to initiation of fluidization (Lennon, Chang, and Weisman 1990). As the flow rate is increased, isolated pockets of disrupted sand migrate upward (Figure 1b). Initiation of fluidization occurs when a spout or boil occurs along this weakened path from the pipe to the sand surface. However, the whole region along the length of the pipe is not fluid at this stage. By further increasing the flow rate, complete or full fluidization occurs when the whole region along the pipe is fluidized (Figure 1c). This region is rather narrow and confined by berms at the sand surface.

Once the region above the pipe is completely fluidized, the slurry can be easily removed by pumping or gravity flow. As slurry is removed, the fluidized region begins to widen into a trench as shown in Figure 1d. The berms and sides of the fluidized region slump inward (Figure 1d) until an equilibrium is reached in two areas of the trench cross-section. In the region close to the pipe, a scour hole forms (Figure 1e). In the area farther up the sides away from the pipe, the sand lies at the submerged angle of repose of the material.

## Use of Fluidizers to Augment Sand Bypassing

Littoral sediment can be trapped or impounded at both natural and man-made obstructions along the coast. Notable among these are inlets and harbor mouths. When inlets and harbor mouths have shoaling problems or downdrift beaches erode because of an interruption in longshore littoral processes, sand bypassing can help to mitigate these adverse effects.

The best use of a fluidizer pipe in sand bypassing is to increase the fluidized zone of a fixed bypassing system. The quantity of sediment that a fixed system can bypass is limited by the sand supplied by littoral transport. In particular, a jet pump or submersible pump creates a crater of fairly limited extent and an operator must wait until the crater refills with sand supplied by littoral processes before pumping once again. A fluidizer pipe, used in conjunction with a fixed slurry pump, can create a long (typically 100-ft to 400-ft) trench that traps sand across a portion of the littoral zone supplying additional slurry to the pump crater (Figure 2).

The basic components required for the systems include:

- One or more fluidizer pipes sloping toward the jet pump crater.
- Water supply pipelines to each fluidizer pipe to carry clear water.

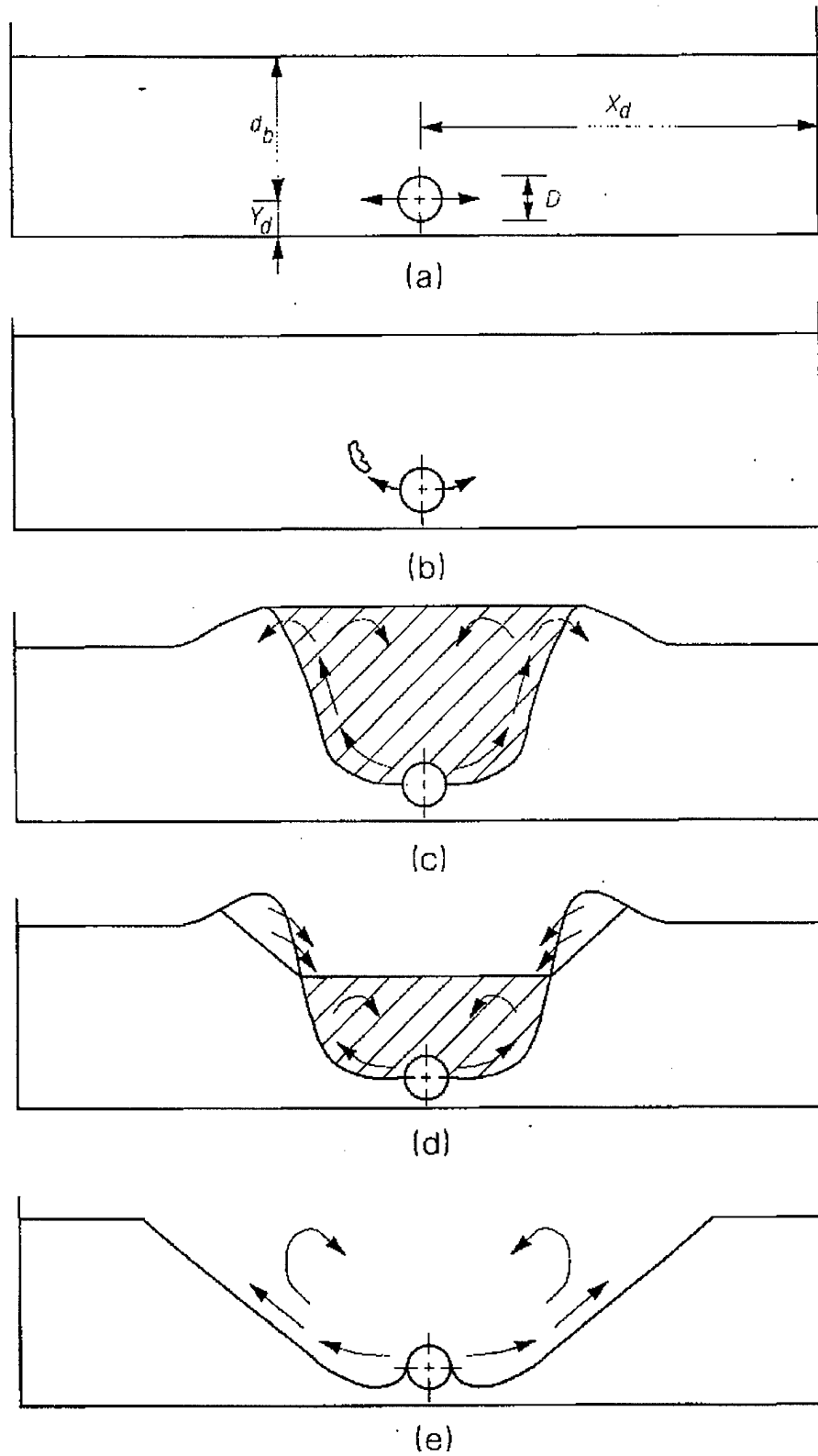

Figure 1. Five stages of fluidization; hatched area indicates the fluidization zone

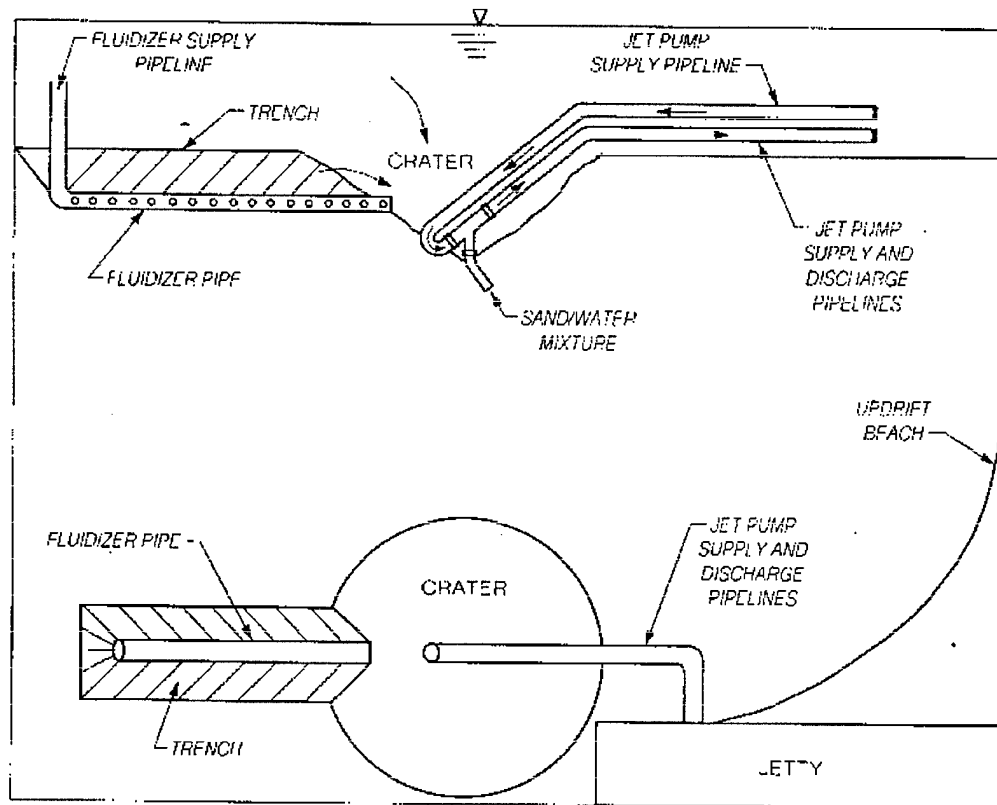

Figure 2. Fluidizer pipe used in conjunction with a fixed slurry pump; hatched area indicates the fluidized zone

- Pumps to provide clear water to the fluidizer pipes.
- Intake facility to ensure that pumps carry clear water to the fluidizer pipes to avoid clogging of holes.
- Supply pump for the jet pump (Richardson and McNair 1981).
- Supply pipeline for the jet pump (Richardson and McNair 1981).
- Discharge pipeline from the jet pump (Richardson and McNair 1981).
- Booster pump and discharge pipeline to deliver slurry to some distant discharge point (Richardson and McNair 1981).

The siting and layout considerations for use of a fluidizer pipe in sand bypassing are similar to those discussed by Richardson and McNair (1981). In particular, much of the discussion on siting of jet pump arrays in Richardson and McNair (1981) is also pertinent to fluidizer pipes.

## Use of Fluidizers for Channel Maintenance

The trench created by removing slurry from the fluidized region above a fluidizer pipe can be used to stabilize and maintain a navigable channel. If the pipe is placed sufficiently deep or if two or more pipes are placed in parallel, the trench dimensions that can be achieved may satisfy the navigation requirements of small shallow-draft vessels.

Once fluidized, slurry in the fluidized region must be removed for the trench to form. For channel formation and maintenance, the slurry may be removed by the following two mechanisms:

- Pumping the slurry out of the trench and placing it on a downdrift beach, as in bypassing.
- Gravity flow of the slurry to carry the sediment out of the trench, perhaps in the seaward and landward directions; a strong ebb current will assist in sediment flowing in a seaward direction.

For channel maintenance, the fluidizer pipe (or parallel pipes) extends along the centerline of the navigation channel (Figure 3). The configuration for a channel maintenance system can take on various forms depending on the slurry removal mechanism. Figure 3 shows a system in which fluidized sand is removed by a submersible pump and delivered to a downdrift beach. The components of this system are similar to the components required for bypassing. For a system that relies on gravity flow or ebb current for slurry removal, only the components associated with the fluidization pipe are required.

## Site Assessment Studies

Design of a fluidizer system for either channel maintenance or bypassing requires an understanding of the coastal processes of the site. At least one year of data collection is needed to appreciate the seasonal variations associated with coastal phenomena and three years of data collection are desirable. Many good references on conducting coastal studies are available, such as the *Shore Protection Manual* (SPM 1984) and the Engineer Manuals "Sand Bypassing" (Headquarters, U.S. Army Corps of Engineers 1991) and "Coastal Littoral Transport" (Headquarters, U.S. Army Corps of Engineers 1992). The coastal processes of particular importance for a fluidizer system design, either for channel maintenance or bypassing, are listed below:

- **Littoral transport.** Both direction and rate of transport must be assessed to estimate the rate of infilling of the trench. This will determine the operation frequency and the disposal rate.
- **Sediment characteristics.** Several sediment characteristics are required for fluidizer design. These include:

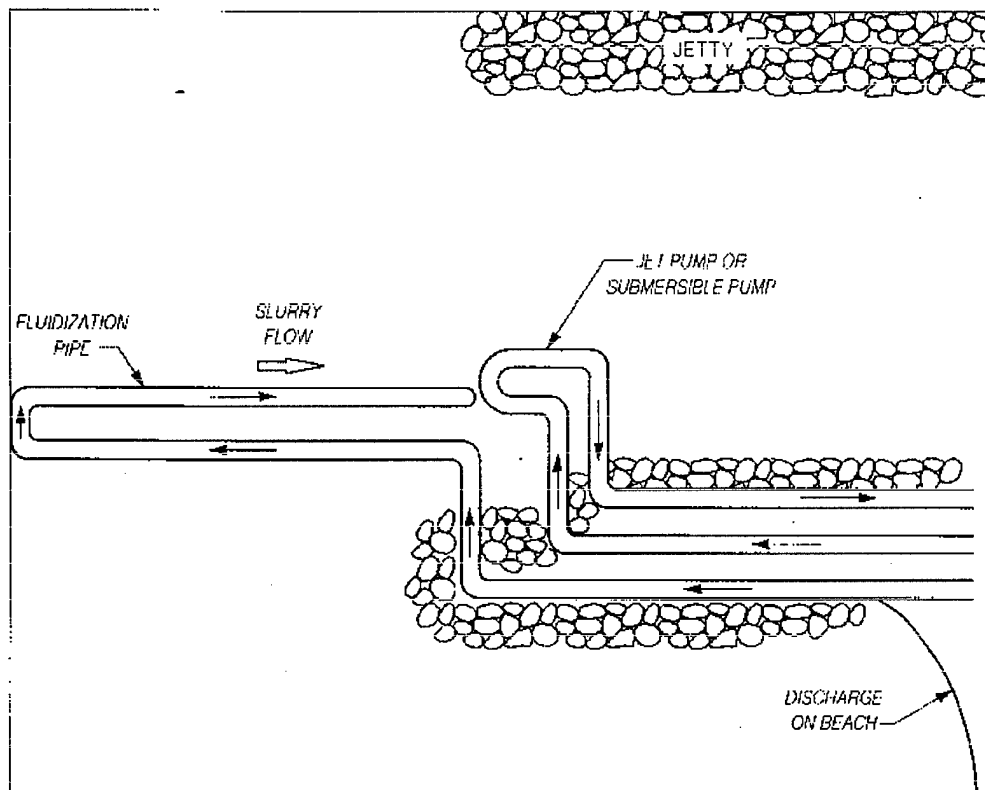

Figure 3. Plan view schematic of the components of a fluidizer system used in a tidal inlet in conjunction with a jet or slurry pump (not to scale)

- Grain size distribution.
- Specific gravity.
- Presence of cohesive materials.
- Permeability.
- Presence of debris.

Because sand in the fluidized region will be removed, in addition to studying the in situ sand, the material that is expected to fill the trench must be determined for refluidization once the trench has filled in. If dredging has already occurred, the nature of the sand that has infilled the dredged area will be known and may be of different composition than the undisturbed material. The sediment samples should be subjected to geotechnical tests to determine the grain size distribution and grain shape and permeameter tests to determine the coefficient of permeability (hydraulic conductivity),  $K$ . Based upon the permeability and grain size distributions, estimates of  $K$  can be made. Procedures for estimating  $K$  are available from many sources, such as Eckert and Callender (1987).

- **Morphology.** A detailed survey of nearshore or inlet bathymetry is required. Also, core samples must be obtained to assess depth and areal extent of sand and to determine whether debris or fine materials are present.
- **Waves, currents, and tides.** A general understanding of these parameters at the site is required for the proper layout of system components. For the channel maintenance design problem, the tidal hydraulics of the inlet or harbor mouth are required, especially if the slurry removal mechanism must rely on tidal currents.

The design of a fluidizer system also requires information about other site-specific items, such as:

- Nearby structures (jetties, walls) and topographic features.
- Description of possible receiving areas for bypassed sediment and routes for pipelines.

## Fluidizer Pipe Design

### Location of Fluidizer Pipe

The goal of fluidization in the coastal environment is to create a trench. Trench size, length, cross-section, and location are the first considerations in the design process (Figure 4).

- The designer must determine the required length of trench,  $L$  (the length of an ebb tidal bar for maintenance of a navigation channel or the width of the littoral zone for sand bypassing).
- If the pipe is buried to a depth  $d_b$  (or placed in a predredged area and allowed to shoal to a depth  $d_b$ ), the top width,  $T$ , can be approximated easily by knowing the angle of repose,  $\phi$ , of the sand;  $T$  is approximately  $2d_b / \tan \phi$ . Table 1 gives values of  $\phi$  for various materials from several reference sources.

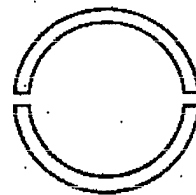
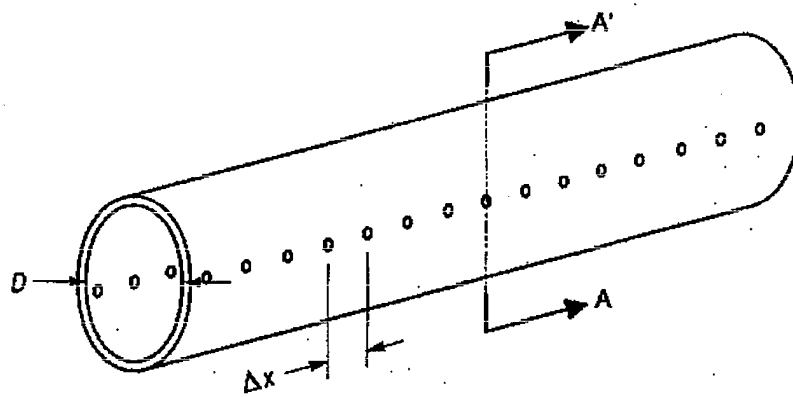
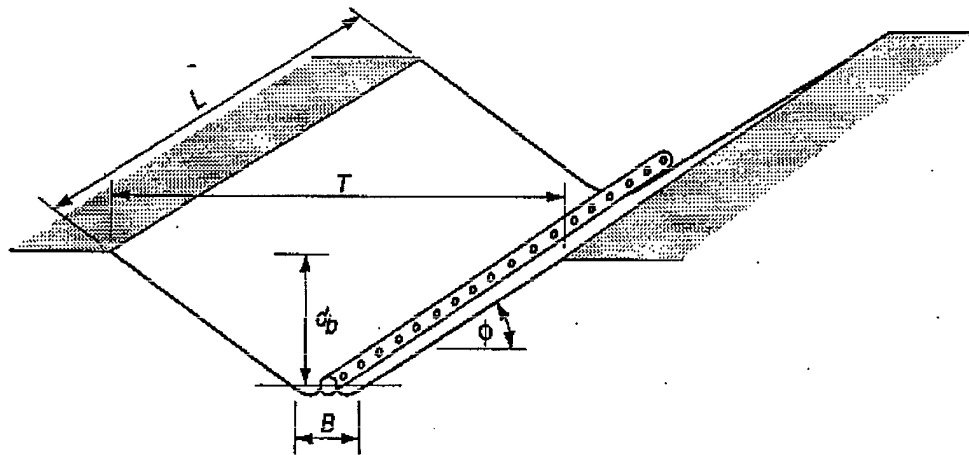

SECTION A-A'

**Figure 4. Definition sketch of a fluidizer pipe after final trench formation**

**Table 1. Typical Range of Values of Angle of Repose of Various Materials**

Soil	$\phi$ , deg	
	Loose	Dense
Sand, angular	32-36	35-45
Sand, beach (well rounded)	28-32	32-38
Gravel, bank run	34-38	38-42
Silty sand	25-35	30-36
Silt, inorganic	25-35	30-35

- The bottom width, B, includes the diameter of the pipe, D, plus the width of the scour holes created by the fluidizer jets. The top width, T, is exactly  $B + 2d_p / \tan \phi$ . Because the scour hole widths are a small fraction of the total top width, T, if burial depth is greater than a few feet, ignoring B provides a slightly conservative estimate of top width.
- To achieve movement of sediment along the trench, the slope of the pipe must be set. For sand bypassing the trench is required to slope toward the excavating pump at about a 0.5 to 2.0 percent slope; hence, the fluidizer pipe should be set to the same slope. For channel maintenance, the pipe will usually be set through the ebb tidal bar. From the field investigation, the bathymetry, including seasonal variations, will be determined. The pipe location is chosen so that the elevation of the seaward end of the pipe is lower; a slope of 0.5 to 2.0 percent is recommended.

Once the designer determines the trench size desired, selection of the flow and pipe parameters to achieve that trench size can proceed.

### Hole Orientation

Hole orientation is the next logical design parameter to select. Based on the experiments of Kelley (1977) and the work of Weisman and others (Weisman and Collins 1979, and Weisman, Collins, and Park 1982), hole orientation is recommended to be horizontally opposed as shown in Figure 4, for the following reasons:

- Kelley (1977) showed that the widest fluidized region is achieved with horizontally opposed holes.
- Weisman and Collins (1979) reasoned that a pipe with upward pointing holes would tend to fill with sand when not in use and a pipe with downward pointing holes would tend to self-bury.

## Flow Rate

Figure 5 is a plot of relative burial depth (burial depth,  $d_b$ , divided by pipe diameter,  $D$ ) versus a flow rate factor,  $Q_1'/Kd_b$ , where  $K$  is the permeability of the sand,  $d_b$  is the bed depth, and  $Q_1'$  is the flow rate per foot of pipe length (Weisman and Lennon, in preparation). The third parameter required to use this plot is the sand domain size,  $X_d/D$ ,  $Y_d/D$ , where  $X_d$  and  $Y_d$  are the horizontal distance from the pipe to the limits of the sand and the depth of the sand layer below the pipe, respectively (see Figure 1a).

The burial depth,  $d_b$ , will be known from the design process. However, the coefficient of permeability,  $K$ , for different coastal sediments can vary by orders of magnitude, and hence is an important part of the design process.

The incipient flow rate to initiate fluidization is obtained from

$$Q_I = (Q_1'/Kd_b) \times K \times d_b \times \text{pipe length} \quad (1)$$

Note that the flow rate factor is only 40 percent higher for the largest domain compared to the smallest domain considered for a relative burial depth of 20, and is less for smaller relative burial depths. If only limited data are available to assess the extent of the sand domain, it is recommended that a conservative value of flow rate factor be used as a safety factor; it is suggested that the top curve in Figure 5 should be used. When additional data become available, the appropriate curve in Figure 5 can be used to reduce the conservative choice using the top curve.

To achieve a trench, full fluidization is essential. In general, the relationship between full and initial fluidization flow rates can be stated as

$$Q_F = F \times Q_I \quad (2)$$

where  $F$  is an empirical factor to be refined with field experience.

At this time, it is recommended that an  $F$  factor of at least 5 (but less than 10) be used. This will ensure full fluidization along the entire length of the pipe.

In conclusion, the determination of flow rate  $Q_F$ , should be approached as follows:

- Determine the depth of burial of the fluidizer pipe,  $d_b$ .
- Determine the extent of sand layer to the side of and below pipe,  $X_d$  and  $Y_d$ , respectively.
- Determine the permeability of the sand,  $K$ .

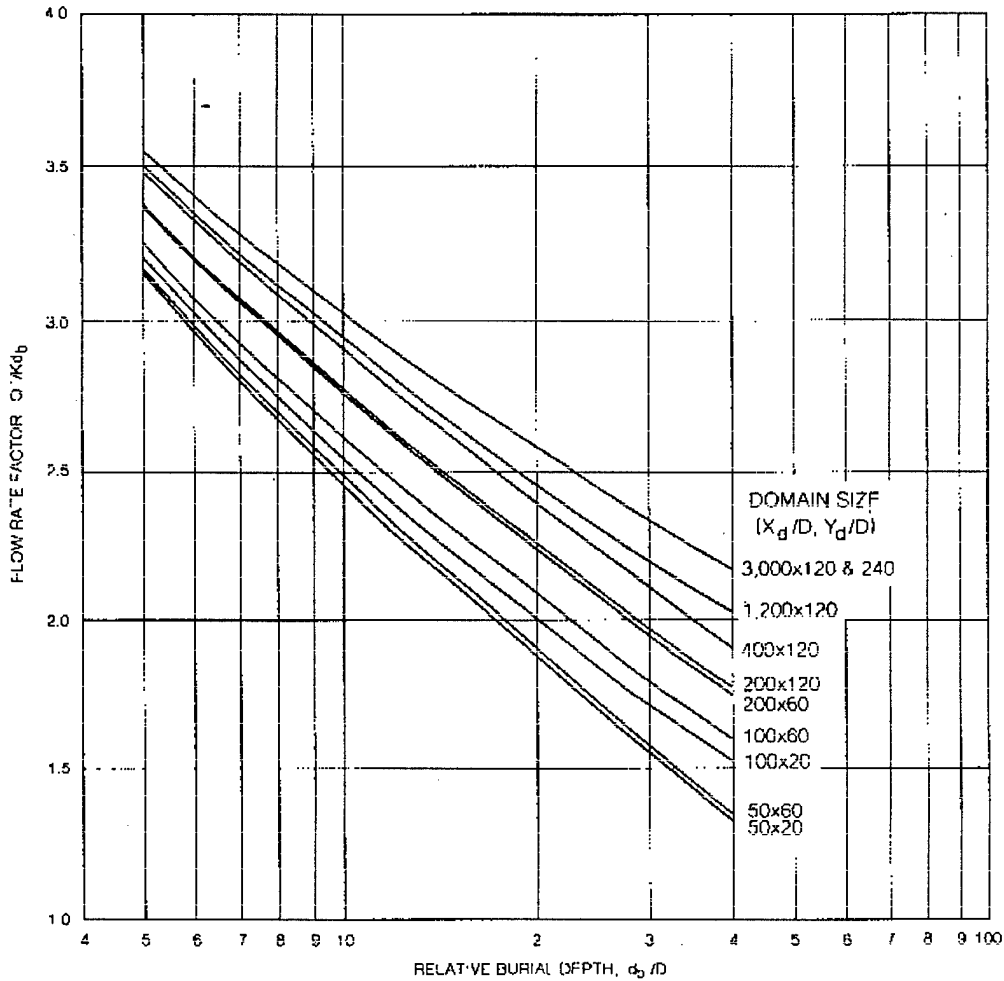

Figure 5. Chart for isotropic conditions providing required flow-rate factor for selected domain sizes (Weisman and Lennon, in preparation)

- Use Figure 5 to obtain a flow rate per unit length of pipe required to initiate fluidization,  $Q_I'$ .
- Multiply  $Q_I'$  by factor F and pipe length to obtain the required full fluidization flow rate,  $Q_F$ .

### Pressure Requirements in Fluidizer Pipe

The pressure or pressure head in the fluidizer pipe must supply the energy to deliver the flow rate per hole through the chosen hole size and through the sediment bed. The total head loss is the sum of the losses through the hole and through the bed.

From experimental values of pressure head at full fluidization and after slurry removal, the difference in values in pipe pressure head is approximately 2 ft of water or less for trench depths of approximately

2 ft. Thus, a pressure head drop of about 1 ft per ft of burial depth is indicated.

For the large, full fluidization flow rate that must be achieved, the pressure in the fluidizer pipe can be calculated as that needed to deliver  $Q_h$  through each hole plus 1 ft of head per ft of trench depth. The pressure can be calculated from the equation for a submerged orifice:

$$Q_h = C_d A_h \sqrt{2g \frac{\Delta p}{\gamma}} \quad (3)$$

where  $C_d$  is the discharge coefficient,  $A_h$  is the hole area,  $\Delta p$  is the change in pressure from inside to outside the hole,  $\gamma$  is the specific weight of water (62.4 lb/cu ft for fresh water and 64 lb/cu ft for salt water), and  $g$  is the acceleration of gravity (32.2 ft/sec squared). For a sharp-edged orifice, the discharge coefficient is approximately 0.61. However, the values of  $C_d$  from experiments (Kelley 1977) range from 0.73 to 0.86, with an average value of 0.79.

In summary, the pressure head in the manifold or fluidizer pipe needed to achieve full fluidization should be calculated by using Equation 3 to calculate pressure drop for water exiting the pipe, and then adding 1 ft per ft of trench depth (below the water/sediment boundary).

### Hole Size and Spacing

Experimentation has shown that hole size and spacing do not have a significant effect on the flow rate required for initiation of fluidization, compared to sand depth and grain size. For full fluidization, the effect of hole size and spacing also is not profound. The recommended values are hole spacings of 1 to 2 in. and hole sizes of 1/8 to 3/16 in. A more detailed discussion of the experimentation with hole size and spacing is given by Weisman and Lennon (in preparation).

### Pipe Size

The fluidizer pipe is a manifold whose function is to provide a uniform flow out of the holes. This requires that the hydraulic head remain fairly constant along the fluidizer pipe. Manifold design is discussed in McNown (1953). A 10- to 12-inch-diameter pipe is a reasonable starting point for design calculations.

### Miscellaneous Constraints

Several limitations and constraints of the methods and ideas discussed on fluidizer pipe design must be included for completeness. Most of the design ideas have evolved through laboratory experimentation; only a rather small amount of information has been gathered through field

experience. The limitations concern sediment size, depth of burial of the fluidizer pipe, length of fluidizer pipe, and slope of pipe.

All experiments and field experience thus far have been with fine to medium sand. There is no experience with either finer or coarser material. As long as fine material is noncohesive, fluidization should work. However, if some cohesive materials are present, there may be difficulty in achieving full fluidization and trench formation (side slopes may not slump). Clearly, it takes much larger flow rates to fluidize medium sand compared to fine sand. There may be a practical limitation to sediment size such that the flow rate requirements to achieve full fluidization become uneconomically large.

Constraints with regard to fluidizer pipe length may result from:

- Limitations either on the pump or pipe size available. To overcome these limitations, the required fluidizer length can be divided into shorter modules.
- Limitations due to pipe slope. If the fluidizer pipe is placed on a 1 percent slope to provide for flow of the slurry to a jet pump, then the downstream end of the pipe may require extremely deep burial if the pipe is long. A 1,000-ft-long pipe would require 10 ft deeper burial at the end. This may have significant implications where clay or rock layers underlie the sands.

## Summary of Design Procedure

The design of any coastal study, including design of fluidization systems, should begin with an office phase followed by a field investigation (SPM 1984). The first step in the office phase is to review existing data and begin the design process. Parameters that can be estimated without a field program should be approximated, and a one- to three-year field investigation should be conducted. The field data should be reviewed, final parameter values selected, and the design implemented. At the conclusion of the data acquisition phase, information should include:

- Estimates of direction and volume of littoral drift.
- Available information on the sediment type, size, and distribution.
- Historical records of morphology and shoreline location.
- A historical survey. This may help identify the geomorphology of the site, providing insight into the nature and nonhomogeneity of the materials encountered. Information on coastal structures and their impact also is needed.
- Seasonal variations in littoral transport rates.

The next step is to determine design conditions by considering how the fluidizer system will interface with the overall system; depending on the location of jet pumps or other equipment, identify constraints on location of fluidizer system. Once the location has been chosen, the design geometry for the trench is selected including slope, location (length), depth (elevation), and width of channel.

Select the design parameters of the fluidization system including the following actions:

- Consider several designs for various burial depths, including multiple parallel pipes if needed to achieve the design width.
- Select design from trial designs.
- Determine pump location and clear water intake.
- Estimate pipe diameter,  $D$ ; choose 1 ft if uncertain.
- Determine incipient flow rate factor  $Q_1'/Kd_b$  from Figure 5 or use a conservative value of 2.6. Required data:  $D$ ,  $d_b$ ,  $K$ , estimated sediment domain size.
- Determine incipient flow rate,  $Q_1$ , from Equation 1.
- Select  $F$  factor;  $F = 5$  to  $10$  is recommended at this time, with  $10$  being the more conservative value.
- Determine full fluidization flow rate by Equation 2:  $Q_F = F \times Q_1$ .
- Select hole geometry (size and spacing) in the fluidizer pipe. Likely selection is horizontally opposed 1/8-in. holes at 2-in. spacing.
- Determine the pressure head requirements in the fluidization pipe, which includes the pressure head loss through the orifice plus a loss through the fluidized bed at full fluidization.
- Conduct hydraulic design of fluidizer pipe diameter,  $D$ , based on maintaining a near constant head along the full length of the fluidizer pipe.
- Select fluidizer pipe material and pump.

Although the frequency of operation criteria can be estimated, it will actually be determined during operation, being "triggered" by accumulated depth of sediment in the trench. The duration of operation will be determined by how long it takes to achieve the refluidized trench design bottom elevation. This will probably be constrained by how fast the jet pump can remove the slurry for sand bypassing operations; hence, the two systems should be sized/ designed together. It is likely that the fluidizer pipe will operate more intermittently than the jet pump. Recent experience with the fluidizer pipes in the Oceanside, California, bypass system indicates that regular (periodic) operation (once every few weeks) is needed to reduce clogging.

## References

- Eckert, J., and Callender, G. 1987. "Geotechnical Engineering in the Coastal Zone," Instruction Report CERC-87-1, U.S. Army Engineer Waterways Experiment Station, Vicksburg, MS.
- Headquarters, U.S. Army Corps of Engineers. 1991 (Jan). "Sand Bypassing," Engineer Manual 1110-2-1616, Washington, DC.
- \_\_\_\_\_. 1992 (Jul). "Coastal Littoral Transport," Engineer Manual 1110-8-3(FR), Washington, DC.
- Kelley, J. T. 1977. "Fluidization Applied to Sediment Transport," Master's thesis, Lehigh University, Bethlehem, PA.
- Lennon, G. P., Chang, F. T., and Weisman, R. N. 1990 (Dec). "Predicting Incipient Fluidization of Fine Sand in Unbounded Domains," *Journal of Hydraulic Engineering*, American Society of Civil Engineers, Vol 116, No. HY12, pp 1454-1467.
- McNown, J. S. 1953 (Aug). "Mechanics of Manifold Flow," *Proceedings of American Society of Civil Engineers*, Vol 79, No. 258, pp 258-1 - 258-22.
- Richardson, T. W., and McNair, E. C. 1981. "A Guide to the Planning and Hydraulic Design of Jet Pump Remedial Sand Bypassing Systems," Instruction Report HL-81-1, U.S. Army Engineer Waterways Experiment Station, Vicksburg, MS.
- Shore Protection Manual*. 1984. U.S. Army Engineer Waterways Experiment Station, Vicksburg, MS.
- Weisman, R. N., and Collins, A. G. 1979 (Oct). "Stabilization of Tidal Inlet Channels - Design Recommendations," Fritz Engineering Laboratory Report No. 710.3, Lehigh University, Bethlehem, PA.
- Weisman, R. N., Collins, A. G., and Parks, J. M. 1982. "Maintaining Tidal Inlet Channels by Fluidization," *Journal of the Waterway, Port, Coastal, and Ocean Division*, American Society of Civil Engineers, Vol 108, No. WW4, pp 526-538.
- Weisman, R. N., and Lennon, G. P. 1992. "A Design Manual for Coastal Fluidization Systems," *Proceedings of Coastal Practice '92*, American Society of Civil Engineers, pp 862-877.
- \_\_\_\_\_. "A Guide to the Planning and Hydraulic Design of Fluidizer System for Sand Management in the Coastal Environment," Dredging Research Program Contract Report in preparation, U.S. Army Engineer Waterways Experiment Station, Vicksburg, MS.