

**Assessment of Waveguide
Vibration Isolator**

John D. Dickens

DSTO-TR-0812

DISTRIBUTION STATEMENT A
Approved for Public Release
Distribution Unlimited

19990713 141

Assessment of Waveguide Vibration Isolator

John D. Dickens

Maritime Platforms Division
Aeronautical and Maritime Research Laboratory

DSTO-TR-0812

ABSTRACT

A method is proposed for comparing the dynamic performance of different types of vibration isolators, and relies on having equal compression ratios of the rubber elements. The method is used to compare a waveguide vibration isolator with a blank vibration isolator. The four-pole parameters of the vibration isolators are measured, and experimental data presented. There appears to be no significant advantage in using the waveguide vibration isolator.

RELEASE LIMITATION

Approved for public release

DEPARTMENT OF DEFENCE | **DSTO**
DEFENCE SCIENCE & TECHNOLOGY ORGANISATION

DTIC QUALITY INSPECTED 4

AQF99-10-1787

Published by

*DSTO Aeronautical and Maritime Research Laboratory
PO Box 4331
Melbourne Victoria 3001 Australia*

Telephone: (03) 9626 7000

Fax: (03) 9626 7999

© Commonwealth of Australia 1999

AR-010-905

February 1999

APPROVED FOR PUBLIC RELEASE

Assessment of Waveguide Vibration Isolator

Executive Summary

A method is proposed for comparing the dynamic performance of different types of vibration isolators, that relies on having equal compression ratios of the rubber elements. The method is used to compare a waveguide vibration isolator with a blank vibration isolator. The waveguide vibration isolator was of a novel design and designed for quietening ships underwater. It had a steel spring within the rubber element that was assumed to act as a waveguide and dissipate energy. The blank vibration isolator had the same design as the waveguide vibration isolator, except it did not have an internal steel spring.

The waveguide and blank vibration isolators were tested using the Vibration Isolator Test Facility developed by the Aeronautical and Maritime Research Laboratory. The vibration isolators were tested under static loads that gave compression ratios of 0.95 and 0.90, which covers the range of compression ratios commonly used in maritime applications. The four-pole parameters of the vibration isolators were measured over the frequency range from 20 Hz to 2 kHz. The operation of the waveguide vibration isolator was measured to be insignificantly affected by its physical inversion.

The effectiveness of a vibration isolator is defined as the ratio between the foundation force obtained when the source and foundation are directly connected across the vibration isolator, and the foundation force obtained with the vibration isolator included. At certain frequencies, longitudinal standing waves are set up within the rubber element of a vibration isolator which cause its effectiveness to significantly diminish. The waveguide vibration isolator has a higher stiffness and loss factor compared with the blank vibration isolator. Consequently the first standing wave frequency is increased from 400 to 550 Hz. Thus the effectiveness of the waveguide vibration isolator is higher at 400 Hz but lower at 550 Hz, compared with the blank vibration isolator. At low frequencies the effectiveness of the waveguide vibration isolator is less than the blank vibration isolator.

The waveguide vibration isolator is designed to have a higher effectiveness compared to the blank vibration isolator, for frequencies above the cut-off frequency of approximately 100 to 500 Hz. This was not evident. The improvement in the effectiveness at 400 Hz could possibly also have been achieved using a blank vibration isolator with a rubber having a higher stiffness and loss factor. In practice, under load the rubber of the waveguide vibration isolator may suffer from fatigue problems arising from high stress concentrations associated with the embedded steel spring. There appears to be no significant advantage in using the waveguide vibration isolator.

Authors

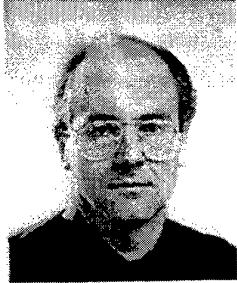

John D. Dickens
Maritime Platforms Division

Dr John Dickens received a B.E. (Hons) degree in 1973 from the University of Tasmania and was awarded a PhD degree from the University of New South Wales in 1998. His career with the Department of Defence began in 1978 at the Engineering Development Establishment. In 1988 he was appointed as the Defence Scientific Adviser to Malaysia for three years, and then joined DSTO Maritime Platforms Division (then known as Ship Structures and Materials Division) where he is still employed. He is currently the task manager of active noise and vibration control for the Navy.

Contents

1. INTRODUCTION.....	1
2. STIFFNESSES OF VIBRATION ISOLATORS	1
3. BASIS OF COMPARISON BETWEEN WAVEGUIDE AND BLANK VIBRATION ISOLATORS.....	3
3.1 Waveguide and Blank Systems	3
4. EXPERIMENTS	5
4.1 Four-pole parameters.....	6
4.2 Vibration Isolator Test Facility	6
4.3 Tests.....	7
5. RESULTS AND DISCUSSION.....	8
6. CONCLUSIONS	10
7. REFERENCES.....	11
APPENDIX A: PHYSICAL PROPERTIES OF VIBRATION ISOLATORS.....	43
APPENDIX B: DYNAMIC TESTS ON RUBBER ELEMENTS	47
APPENDIX C: STATIC TESTS ON RUBBER ELEMENTS.....	49
APPENDIX D: EFFECTIVENESS OF A VIBRATION ISOLATOR	51

1. Introduction

This report explains the characterisation and assessment of a novel vibration isolator that had been previously proposed, Wendlandt (to be published). This required the development of a method to compare different types of vibration isolators. The novel vibration isolator was designated as the waveguide vibration isolator, and was designed for quietening ships underwater. It had a regular right cylindrical shape with a steel plate bonded to each end of a rubber element, and had a steel spring within the rubber element which was attached to the upper end plate and assumed to act as a waveguide and dissipate energy.

To assess the effect of the steel spring another vibration isolator was manufactured, termed the blank vibration isolator. It was the same as the waveguide vibration isolator but without the internal spring. Photographs of the vibration isolators are shown in Figures 1 to 3, and their physical details are given in Appendix A. The waveguide vibration isolator was designed to have a higher effectiveness of vibration isolation compared to the blank vibration isolator, for frequencies above the cut-off frequency of the waveguide. The cut-off frequency was designed to be approximately 100 to 500 Hz.

Complex quantities are denoted by superscripted asterisks, for example F_D^* .

2. Stiffnesses of Vibration Isolators

A vibration isolator is considered to comprise a rubber element that is securely bonded to two end plates used for attaching the vibration isolator to the upper and lower structures. The rubber element may include a steel spring, as in the case of the waveguide vibration isolator. The upper structure is assumed to be the vibratory source such as a machine, and the lower structure the foundation such as the hull of a ship or submarine.

Consider a vibration isolator that has a bottom plate attached to a rigid foundation, and a top plate that is subjected to a dynamic sinusoidal force excitation superposed on a static compressive load. The rubber surface that is attached to the top plate is assumed to have a uniform static compressive force F_S and a complex dynamic force F_D^* of amplitude $F_D = |F_D^*|$ applied to it, with a corresponding static displacement of X_S and a complex dynamic displacement X_D^* of amplitude $X_D = |X_D^*|$. The dynamic force is of sinusoidal form with frequency f and the phase angle between the dynamic force and displacement is the loss angle δ . This is the same loss angle as the complex normal and shear moduli of the rubber element, Snowdon (1968). The curve of force against displacement for the vibration isolator is shown in Figure 4, where the hysteresis loop due to the internal damping of the rubber element has been

exaggerated for clarity and is represented by an ellipse with its major axis defined by the points P_1 and P_2 . The static operating point is P_0 , and the tangent to the curve at point P_0 is the line P_0-X_{S1} .

The static stiffness corresponds to the applied load being slowly increased or decreased, which allows the static load deflection curve to be measured by means of a slowly changing applied force, ISO 2017:1982 and AS 2972-1987. The secant, static and complex dynamic stiffnesses (see ISO 2041:1990 and AS 2606-1983) are symbolised as k_C , k_S and k_D^* respectively, and are defined as

$$k_C = \frac{F_S}{X_S} \quad (1)$$

$$k_S = \frac{F_S}{X_S - X_{S1}} \quad (2)$$

and

$$k_D^* = \frac{F_D^*}{X_D^*} \quad (3)$$

Note that the secant stiffness is also referred to as the point or chord stiffness. The secant and static stiffnesses are real numbers, whereas the dynamic stiffness is a complex number of magnitude $k_D = |k_D^*|$. The secant and dynamic stiffnesses are measured in Appendices B and C. In general, as the frequency decreases, so does the magnitude of the dynamic stiffness and asymptotically approaches the static stiffness. This was experimentally shown by Jackson, King and Maguire (1954 and 1956), who measured the absolute value of the dynamic stiffness of poly(dimethyl siloxane), poly(isobutene-co-isoprene), and natural rubber specimens over the frequency range from 0.00167 to 200 Hz. In general,

$$k_D > k_S > k_C \quad (4)$$

Let the waveguide and blank vibration isolators have dynamic stiffness magnitudes of k_{D1} and k_{D2} respectively, and secant stiffnesses of k_{C1} and k_{C2} respectively. Let the ratio of the magnitude of the dynamic to secant stiffnesses of the waveguide and blank vibration isolators be a_1 and a_2 respectively, defined by

$$a_1 = \frac{k_{D1}}{k_{C1}} \quad (5)$$

and

$$a_2 = \frac{k_{D2}}{k_{C2}} \quad (6)$$

3. Basis of Comparison between Waveguide and Blank Vibration Isolators

The waveguide and blank vibration isolators were designed to support machines and reduce their transmitted forces to the foundations. Consider the single degree-of-freedom system comprising a mass supported by the waveguide vibration isolator on a rigid foundation, and termed the waveguide system. Consider also the single degree-of-freedom system comprising the same mass supported by the blank vibration isolator on a rigid foundation, and called the blank system. The inclusion of the steel spring stiffened the rubber element of the waveguide vibration isolator. Thus the magnitudes of the dynamic, secant and static stiffnesses of the waveguide system would be greater than those of the blank system. The waveguide vibration isolator is therefore capable of supporting a larger mass than the blank vibration isolator.

Therefore, the natural frequency of the waveguide system would be higher than that of the blank system. From Appendix D this would result in a decreased effectiveness of the waveguide system compared to the blank system, for frequencies above the natural frequency of the waveguide system. Also, the static strain of the rubber element in the waveguide system would be less than that of the blank system, and so the properties of the rubber elements would differ. This would introduce differences in the effectiveness of the two systems.

These changes in the effectiveness were caused by the stiffening effect of the steel spring, and not by the designed waveguide action of dissipating energy. A valid comparison of the waveguide and blank vibration isolators should therefore eliminate these changes.

3.1 Waveguide and Blank Systems

Consider an idealised single degree-of-freedom system comprising a mass supported by a linear spring on a rigid foundation. Let the system have a natural frequency of f_n , the static deflection of the mass be δ and the gravitational constant be g . Then it may be shown that, Muster and Plunkett (1988),

$$f_n = \frac{1}{2\pi} \sqrt{\frac{g}{\delta}} \quad (7)$$

Equation (7) assumes that the dynamic and secant stiffnesses of the spring are equal, which is true for a linear spring but not for an element incorporating rubber, Section 2. Therefore, to apply equation (7) to the waveguide and blank systems, the stiffness ratios a_1 and a_2 must be included. Let the natural frequencies of the waveguide and blank systems be f_1 and f_2 respectively. Furthermore, let the static deflections of the

masses supported by the waveguide and blank vibration isolators be δ_1 and δ_2 respectively. Then application of equation (7) with the inclusion of the factors a_1 and a_2 yields

$$f_1 = \frac{1}{2\pi} \sqrt{\frac{ga_1}{\delta_1}} \quad (8)$$

and

$$f_2 = \frac{1}{2\pi} \sqrt{\frac{ga_2}{\delta_2}} \quad (9)$$

Combining equations (8) and (9) gives

$$\frac{f_1}{f_2} = \sqrt{\frac{a_1\delta_2}{a_2\delta_1}} \quad (10)$$

If $a_1 \approx a_2$, then $f_1 = f_2$ implies from equation (10) the approximation that

$$\delta_1 = \delta_2 \quad (11)$$

The compression ratio of a vibration isolator is defined as the static compressed height of the rubber element under load, divided by its uncompressed height. Thus the compression ratio of an unloaded vibration isolator is unity. Equation (11) implies that the compression ratios of the two vibration isolators are equal, and thus their rubber elements should have the same material properties, excluding the effects of the steel spring.

Therefore the changes in the force transmissibilities arising from the stiffening effect of the steel spring may be minimised by employing equal static deflections in the waveguide and blank systems. This assumes that the ratios of the magnitudes of the dynamic to secant stiffnesses of the waveguide and blank vibration isolators are equal. The ratios a_1 and a_2 are measured in Appendix C. The variations in the ratio a are respectively 1.6 and 8.9 %, referenced to the values for the blank vibration isolator. The difference in the natural frequencies is 0.8 % and 4.5 % referenced to the blank vibration isolator, respectively for compression ratios of 0.95 and 0.90, Appendix C. Furthermore, equation (10) implies that the ratio f_1/f_2 equals 1.02 and 0.954 for compression ratios of 0.95 and 0.90, respectively. For frequencies well above the natural frequency of a lightly damped single degree-of-freedom system, the graph of the magnitude of the force transmissibility against frequency asymptotes to a slope of -40 dB/decade, Muster and Plunkett (1988). Therefore, the difference in the force transmissibilities of the waveguide and blank vibration isolator systems, arising from their different natural frequencies, asymptotes to 0.27 and -0.81 dB for compression ratios of 0.95 and 0.90, respectively.

The effectiveness of a vibration isolator is defined as the ratio between the foundation force obtained when the source and foundation are directly connected across the vibration isolator, and the foundation force obtained with the vibration isolator included. For frequencies well above the natural frequency of a lightly damped single degree-of-freedom system, the graph of the magnitude of the effectiveness against frequency asymptotes to a slope of 40 dB/decade, Appendix D. Therefore, the difference in the effectiveness of the waveguide and blank vibration isolator systems, arising from their different natural frequencies, asymptotes to -0.27 and 0.81 dB for compression ratios of 0.95 and 0.90, respectively.

Thus the assumption that $a_1 = a_2$ introduces an error in the magnitudes of the force transmissibility and effectiveness of less than 1 dB. This error is considered to be insignificant, and so the assumption is deemed to be valid.

It is therefore proposed to compare the waveguide and blank vibration isolators under conditions of equal compression ratios. This implies that supported masses will have approximately the same natural frequencies. It also means that the rubber elements will have equal static strains, and thus the effect of this parameter on the dynamic properties of the rubber elements will be equal. This is an approximation, since the inclusion of the steel spring must modify the local strains and behaviour within the rubber element. The range of compression ratios commonly used in maritime applications is from 0.95 to 0.90. Thus the vibration isolators will be tested at compression ratios of 0.95 and 0.90, which equate to strains in the rubber elements of 5 and 10 %, respectively.

4. Experiments

The waveguide and blank vibration isolators were tested under static load and in two configurations:

1. The vibration isolators were operated in the upright position. For the waveguide vibration isolator, the excitation was applied to the end plate with the attached spring.
 2. The vibration isolators were operated in the inverted position. For the waveguide vibration isolator, the excitation was applied to the end plate not attached to the spring.
- For each configuration, the vibration isolators were tested at compression ratios of 0.95 and 0.90.

The tests were conducted using the vibration isolator test facility. Details of the facility and testing methodology are given by Dickens (1998). A brief description is given in Sections 4.1 and 4.2.

4.1 Four-pole parameters

The rubber in a vibration isolator causes it to have non-linear behaviour. In common practice the vibration isolator supports a machine and is subjected to a dynamic force superposed on a static load. Under normal operation, the input dynamic vibration amplitudes are generally much smaller than the compressed height of the rubber. The vibration isolator thus operates dynamically about a static point on its force displacement curve. For small dynamic strains of not greater than 1×10^{-3} , the complex normal modulus may be treated as constant, Payne (1956) and Payne and Scott (1960). Under these conditions the dynamic characteristics of a vibration isolator may be considered to be linear with respect to displacement, but still frequency dependent.

Therefore a vibration isolator may be dynamically represented as a pseudo-linear system, Figure 5, where the dynamic force and velocity at its input are denoted by F_1^* and V_1^* respectively, and the dynamic force and velocity at its output by F_2^* and V_2^* respectively. Let α_{11}^* , α_{12}^* , α_{21}^* and α_{22}^* denote the four-pole parameters, which are complex, time invariant functions of the frequency f . The four-pole parameters relate the input and output forces of the vibration isolator and are defined by, Molloy (1957)

$$\begin{bmatrix} F_1^* \\ V_1^* \end{bmatrix} = \begin{bmatrix} \alpha_{11}^* & \alpha_{12}^* \\ \alpha_{21}^* & \alpha_{22}^* \end{bmatrix} \begin{bmatrix} F_2^* \\ V_2^* \end{bmatrix} \quad (12)$$

The description of a vibration isolator in terms of the four-pole parameters offers three main advantages over traditional methods, Dickens (1998). The first is that the characterisation is independent of the testing method and arrangement. The second advantage is that the mass effects of the vibration isolator at high frequencies are included, such as longitudinal standing waves. The third advantage is that the four-pole parameters of a complicated system may be investigated by studying the four-pole parameters of its constituent parts.

4.2 Vibration Isolator Test Facility

The Vibration Isolator Test Facility measures the four-pole parameters of a vibration isolator under service conditions. It is capable of measuring the four-pole parameters over the frequency range from 5 Hz to 2 kHz, static load range from 1 to 30 kN, and temperature range from 6 to 60 °C. It can test practical vibration isolators having dynamic stiffness magnitudes of at least 1×10^5 N/m, masses of at least 0.5 kg, and loss factors of at least 0.03.

The test rig of the facility is designed to test the axial i.e. vertical direction, which is normally the primary direction of interest, Figure 6. It may also test the lateral directions with appropriate attachments. The vibration isolator under test is mounted

between two large masses, and static load is applied by air-bags positioned above and beneath the two masses. The dynamic load is applied by an electro-dynamic shaker via the upper mass, and the lower mass provides a reaction force to the output force of the vibration isolator.

The upper and lower masses are termed the excitation and blocking masses, respectively. A spacer is used above the blocking mass to allow for the height of the waveguide and blank vibration isolators. The rig has two supporting frames, the upper frame that supports the shaker and the lower frame that provides the reaction forces for the upper static loading air-bags. The excitation mass is laterally constrained by chains attached to the lower frame. The upper and lower frames are respectively termed the shaker support frame and the static load support frame. The lower static loading air-bags sit on a base plate mounted on top of a seismic mass.

Two frames are used to reduce coupling between the static loading structure and the shaker. The shaker is decoupled from its supporting frame by four isolation hangers and drives the excitation mass through a single centrally located connecting rod. The seismic mass is a block of reinforced concrete of mass 22 t. The use of the seismic mass decouples the blocking mass from the laboratory floor, reducing the input of extraneous forces and transmissions from the two supporting frames and the environment.

Air-bags are used to provide the static load as the static force can be easily adjusted, while at the same time giving a degree of isolation between the masses and the supporting structures. The motions of the excitation and blocking masses are measured using accelerometers.

The input force to the vibration isolator is the dynamic force applied by the excitation mass to the vibration isolator and is measured directly by the upper force measuring assembly. The output force is the dynamic force applied by the vibration isolator to the blocking mass and is determined directly by the lower force measuring assembly.

4.3 Tests

Vibration isolators used in machinery spaces on board naval ships experience temperatures that cover the approximate band from 10 to 55 °C, with a bandwidth of 45 °C. The 10 % temperature point is defined as the temperature at 0.1 of the bandwidth, i.e. $10 + 0.1 \times 45 = 14$ °C. Likewise the 90 % temperature point is defined as the temperature at 0.9 of the bandwidth, i.e. $10 + 0.9 \times 45 = 51$ °C. A more common band is from the 10 to 90 % temperature points, i.e. from 14 to 51 °C. Thus the representative operating temperature band for testing purposes was deemed to be from 14 to 51 °C.

A similar rubber type to that used in the waveguide and blank vibration isolators was tested using a Polymer Laboratories Dynamic Mechanical Thermal Analyser mark 3 (DMTA). The DMTA tests showed that over the temperature range from 14 to 51 °C,

the magnitude of the complex normal modulus and loss factor of the rubber increased with decreasing temperature. Therefore, the effectiveness of the blank vibration isolator reduces with decreasing temperature, Dickens (1988). It may therefore be argued that it is more important at low temperatures for the waveguide vibration isolator to exhibit improved performance compared to the blank vibration isolator. Hence it was decided to test the vibration isolators at the lower limit of the representative operating temperature band, viz 14 °C.

The strain and temperature history of a filled rubber affects its dynamic properties. To remove these effects it is necessary to condition a rubber test piece prior to testing. The standard BS 903:Part A24:1992 stipulates that prior to testing a rubber test piece, it should be mechanically conditioned with at least six cycles at the maximum strain. This mechanical conditioning is intended to remove the irreversible 'structure', and is also known as scragging. It has the effect of stress softening the rubber for static deformations. The standard also stipulates that at each test temperature the test piece should be conditioned for sufficient time to reach equilibrium.

Thus prior to testing, each vibration isolator was mechanically conditioned by deforming its rubber element to a compression ratio of 0.85, and then releasing the deforming force. This was repeated six times for each vibration isolator. Also prior to testing, the rubber elements were conditioned at 14±1 °C for at least 16 hours. The time of 16 hours was determined to be sufficient for the rubber elements to attain internal thermal equilibrium. The small temperature variation of ±1 °C ensured that the complex normal moduli of the rubber elements were not significantly affected by the temperatures, as determined by the DMTA tests.

The four-pole parameters of the vibration isolators were measured over the frequency range from 20 Hz to 2 kHz and at a temperature of 14±1 °C. The vibration isolator was maintained at a constant temperature by enclosing it within a temperature enclosure. Figure 7 shows the waveguide vibration isolator under test, where the temperature enclosure has been removed for clarity. The dynamic strain amplitude was controlled not to exceed 1×10^{-3} , which ensured that the complex normal moduli of the rubber elements were not significantly affected by the strain amplitudes, Payne (1956) and Payne and Scott (1960).

5. Results and Discussion

The four-pole parameters of both vibration isolators were measured in configurations 1 and 2 for compression ratios of 0.95 and 0.90, Figures 8 to 23. The abbreviations "wg" and "bl" respectively refer to "waveguide vibration isolator" and "blank vibration isolator". The four-pole parameters are complex quantities designated as α_{11}^* , α_{12}^* , α_{21}^* and α_{22}^* . The blank vibration isolator is symmetrical, and so the four-pole

parameters α_{11}^* and α_{22}^* are equal. Because the waveguide vibration isolator is asymmetrical, it was necessary to use the reversal technique to determine its four-pole parameters, Meltzer and Melzig-Thiel (1980). For compression ratios of 0.95, the upper frequency limit of the measurements was 1250 Hz.

The effectiveness of a vibration isolator depends upon its four-pole parameters, the mobility of the supported machinery and the mobility of the foundation. Assume that the machinery is a rigid mass, and the foundation has infinite stiffness with zero mobility. The static force required to deform the vibration isolators to compression ratios of 0.95 and 0.90 were measured, and converted to equivalent mass loads. These masses were respectively 115 and 243 kg for the blank vibration isolator, and 852 and 1995 kg for waveguide vibration isolator. Using these mass values with the corresponding measured four-pole parameters yielded the effectiveness of the vibration isolators at compression ratios of 0.95 and 0.90, Figures 24 to 27. The effectiveness of the waveguide vibration isolator is essentially the same for configurations 1 and 2. This means that its operation is not significantly affected by inversion.

The effectiveness of the waveguide vibration isolator compared to the blank vibration isolator is defined as the ratio between the foundation force obtained with the blank vibration isolator, and the foundation force obtained with the waveguide vibration isolator. It is a measure of the improvement obtained by using the waveguide vibration isolator compared to the blank vibration isolator, and is termed the effectiveness change, Figures 28 and 29. For positive magnitudes expressed in dB, the waveguide vibration isolator has better effectiveness than the blank vibration isolator. For negative dB magnitudes, the waveguide vibration isolator has worse effectiveness than the blank vibration isolator.

The effectiveness change is essentially the same for configurations 1 and 2. This is expected because the operation of the waveguide vibration isolator is not significantly affected by inversion. The comments in the following two paragraphs regarding the effectiveness change apply for both configurations. Effectiveness changes that are "up" and "down" mean that the waveguide vibration isolator has better and worse performance than the blank vibration isolator, respectively.

Consider the effectiveness change at a compression ratio of 0.95, Figure 28. Up to a frequency of 170 Hz, it is down by a maximum of 2 dB. Over the frequency range from 170 to 480 Hz, it is up by a maximum of 12 dB. Over the frequency range from 480 to 660 Hz, it is down by a maximum of 7 dB. Over the frequency range from 660 to 1250 Hz, it is up by 12 dB at 780 Hz and down by 16 dB at 1240 Hz.

Consider the effectiveness change at a compression ratio of 0.90, Figure 29. Up to a frequency of 300 Hz, it is down by a maximum of 6 dB. Over the frequency range from 300 to 450 Hz, it is up by a maximum of 8 dB. Over the frequency range from 450 to 800

Hz, it is down by a maximum of 14 dB. Over the frequency range from 800 to 2000 Hz, it is up by 9 dB at 1270 Hz and down by 21 dB at 1240 Hz.

The waveguide vibration isolator has a first standing wave frequency of 550 Hz, for compression ratios of 0.95 and 0.90. The blank vibration isolator has a first standing wave frequency of 400 Hz, for compression ratios of 0.95 and 0.90. The effectiveness troughs at the first standing wave frequencies of the waveguide vibration isolator are smaller than those of the blank vibration isolator. This is as expected, because the rubber element of the waveguide vibration isolator has a higher stiffness and loss factor than the rubber element of the blank vibration isolator, Appendix B. The standing waves reduce the effectiveness of a vibration isolator. Consequently, the peak in the effectiveness change at 400 Hz is due to the standing waves in the blank vibration isolator. Also, the trough in the effectiveness change at 550 Hz is due to the standing waves in the waveguide vibration isolator.

6. Conclusions

A method of comparing different vibration isolators has been developed and applied to the waveguide and blank vibration isolators. It compares the vibration isolators at the same compression ratio.

The operation of the waveguide vibration isolator is not significantly affected by physical inversion. The waveguide vibration isolator has a higher stiffness and loss factor compared to the blank vibration isolator. Consequently the first standing wave frequency is increased from 400 to 550 Hz, and the corresponding magnitude of the effectiveness trough increased. Thus the effectiveness of the waveguide vibration isolator is higher at 400 Hz but lower at 550 Hz, compared to the effectiveness of the blank vibration isolator. At compression ratios of 0.95 and 0.90, for frequencies below approximately 170 and 300 Hz respectively the effectiveness of the waveguide vibration isolator is lower compared to the blank vibration isolator. At compression ratios of 0.95 and 0.90, for frequencies above 170 and 300 Hz respectively, the effectiveness of the waveguide vibration isolator is alternately higher and lower compared to the blank vibration isolator.

The waveguide vibration isolator is designed to have a higher effectiveness compared to the blank vibration isolator, for frequencies above the cut-off frequency of approximately 100 to 500 Hz. This was not evident. The improvement in the effectiveness at 400 Hz could possibly also have been achieved using a blank vibration isolator with a rubber having a higher stiffness and loss factor. In practice, under load the rubber of the waveguide vibration isolator may suffer from fatigue problems arising from high stress concentrations associated with the embedded steel spring. There appears to be no significant advantage in using the waveguide vibration isolator.

7. References

CREDE, C.E. and RUZICKA, J.E. (1988), "Theory of Vibration", Chapter 30 in *Shock and Vibration Handbook*, edited by C.M. Harris, McGraw-Hill Book, New York, U.S.A., third edition, 1988.

DICKENS, J.D. (1998), Dynamic Characterisation of Vibration Isolators, Ph.D. Thesis, *University of New South Wales*, April 1998.

JACKSON, R.S., KING, A.J. and MAGUIRE, C.R. (1956), Determination of the Static and Dynamic Elastic Properties of Resilient Materials, *Acustica*, vol. 6, pp. 164-167, 1956.

MELTZER, G. and MELZIG-THIEL, R. (1980), Experimental Determination and Practical Application of the Four-Pole Parameters of Structure-borne Sound Isolators, *Archives of Acoustics*, vol. 5, no. 4, pp. 315-336, 1980.

MOLLOY, C.T. (1957), Use of Four-Pole Parameters in Vibration Calculations, *Journal of the Acoustical Society of America*, pp. 842-853, vol. 29, no. 7, 1957.

MUSTER, D. and PLUNKETT, R. (1988), "Isolation of Vibrations" Chapter 13 in *Noise and Vibration Control*, second edition, edited by L.L. Beranek, Institute of Noise Control Engineering, Washington, D.C., U.S.A., 1988.

PAYNE, A.R. (1956), A Note on the Existence of a Yield Point in the Dynamic Modulus of Loaded Vulcanizates, *Journal of Applied Polymer Science*, vol. 33, p. 432, 1956.

PAYNE, A.R. and SCOTT, J.R. (1960), *Engineering Design with Rubber*, MacLaren & Sons, London, U.K., 1960.

SNOWDON, J.C. (1968), *Vibration and Shock in Damped Mechanical Systems*, John Wiley & Sons, New York, U.S.A., 1968.

WENDLANDT, B.C.H. (to be published), Sound Absorbing and Decoupling Isolators in Ship Structures, *Defence Science and Technology Organisation, Aeronautical and Maritime Research Laboratory*, Melbourne, Australia.

Standards

AS 2606-1983, *Australian Standard Vibration and Shock - Vocabulary*, Standards Association of Australia, North Sydney, Australia, 1983.

AS 2972-1987, *Australian Standard Vibration and Shock - Isolators - Procedures for Specifying Characteristics*, Standards Association of Australia, North Sydney, Australia, 1987.

BS 903:A24:1992, *British Standard Physical Testing of Rubber, Part A24: Guide to the Determination of Dynamic Properties of Rubbers*, British Standards Association, London, U.K., 1992.

ISO 2017:1995, *International Standard Vibration and shock - Isolators - Procedure for Specifying Characteristics*, International Organization for Standardization, second edition 1982, Geneva, Switzerland, reconfirmed 1995.

ISO 2041:1990, *International Standard Vibration and Shock - Vocabulary*, International Organization for Standardization, second edition, Geneva, Switzerland, 1990.

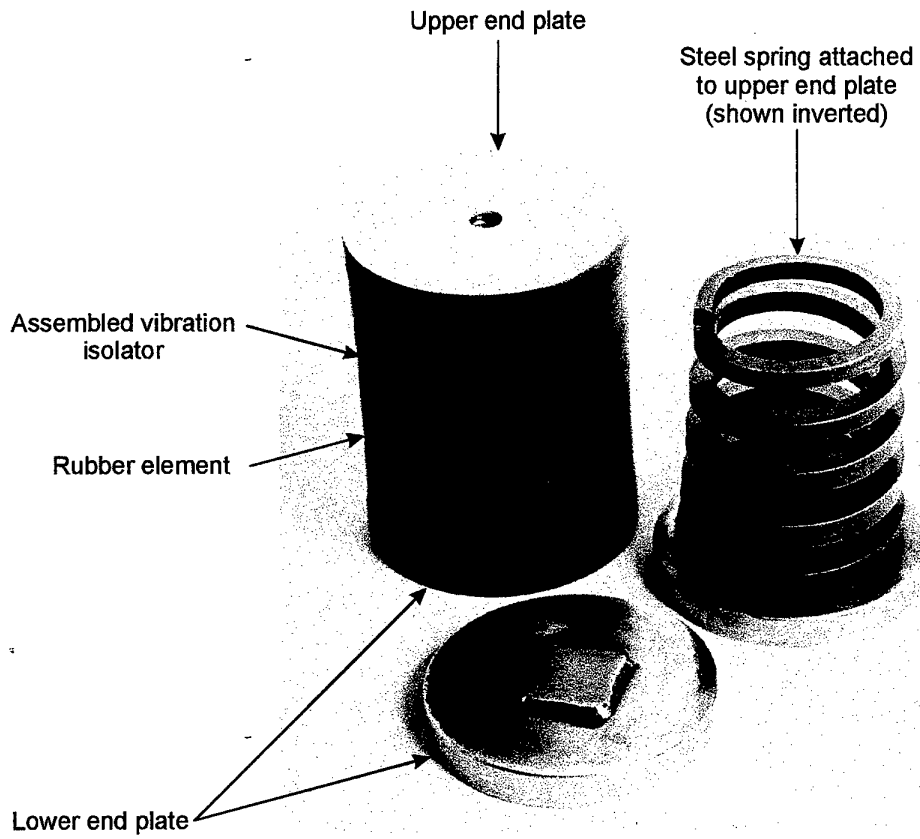

Figure 1 Waveguide vibration isolator.

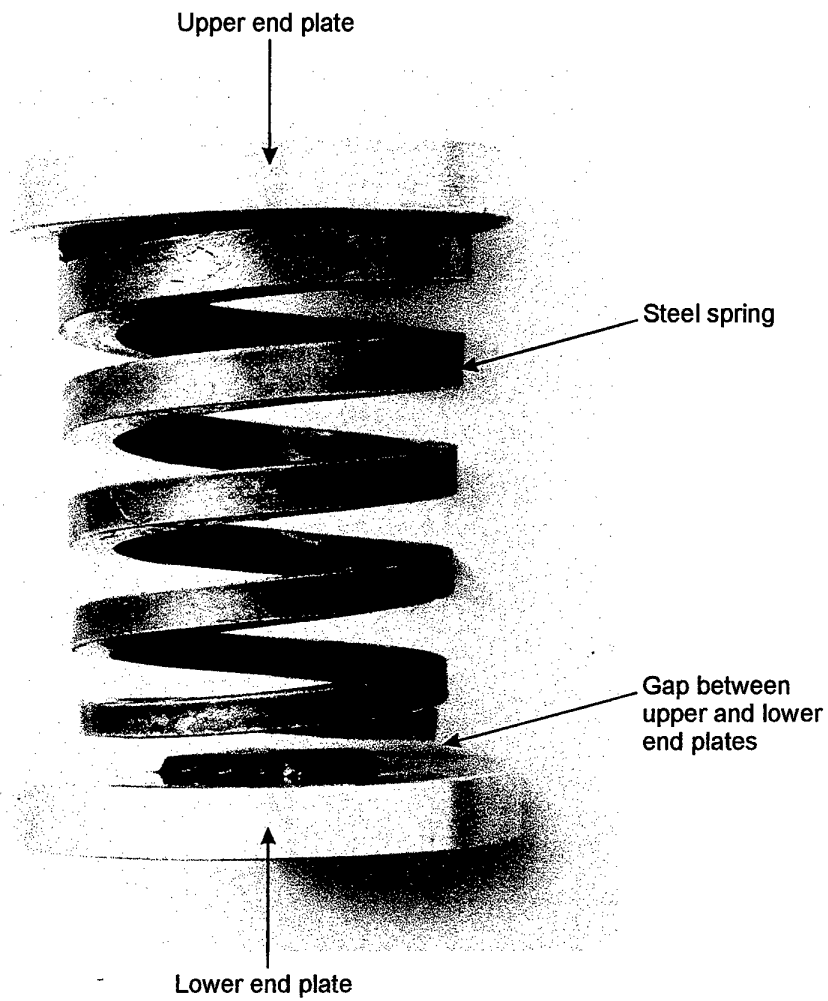

Figure 2 Steel components of waveguide vibration isolator.

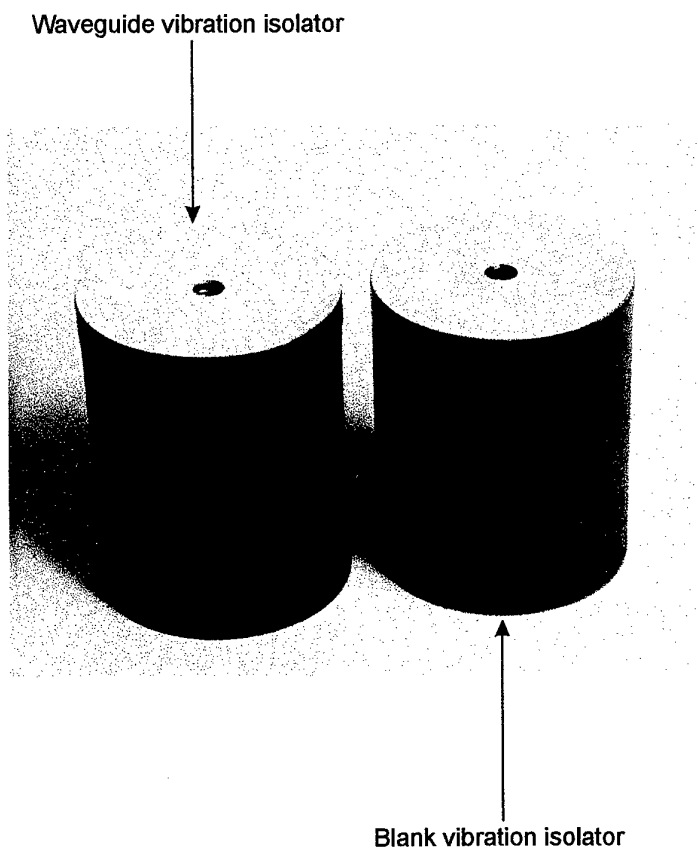

Figure 3 *Vibration isolators.*

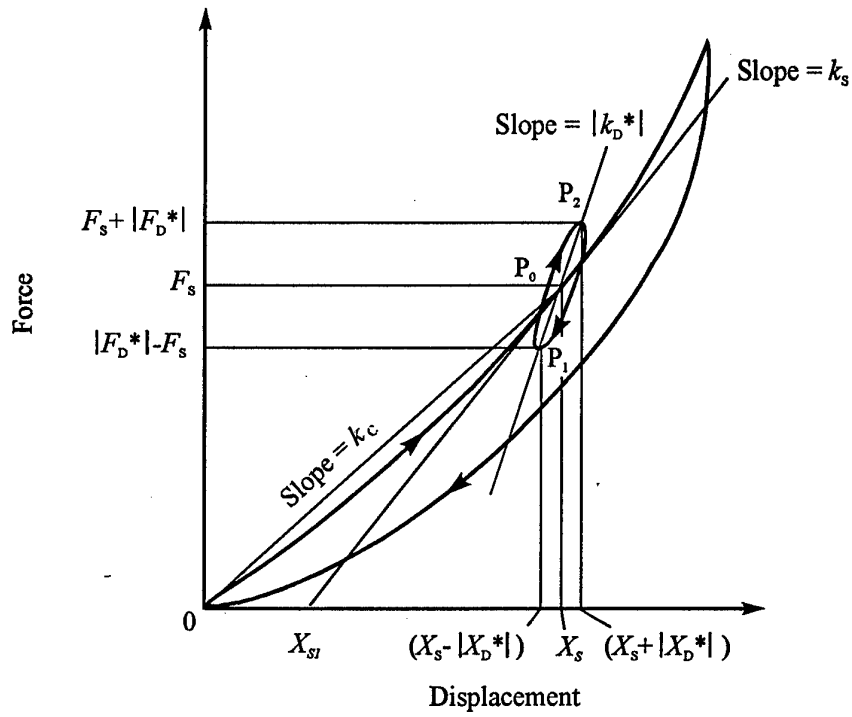

Figure 4 Force against displacement curve for a vibration isolator.

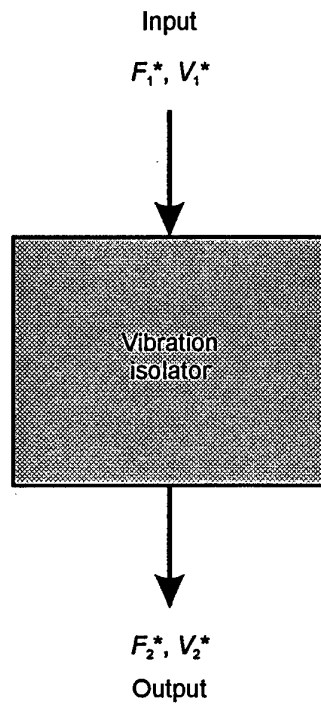

Figure 5 Block representation of a vibration isolator.

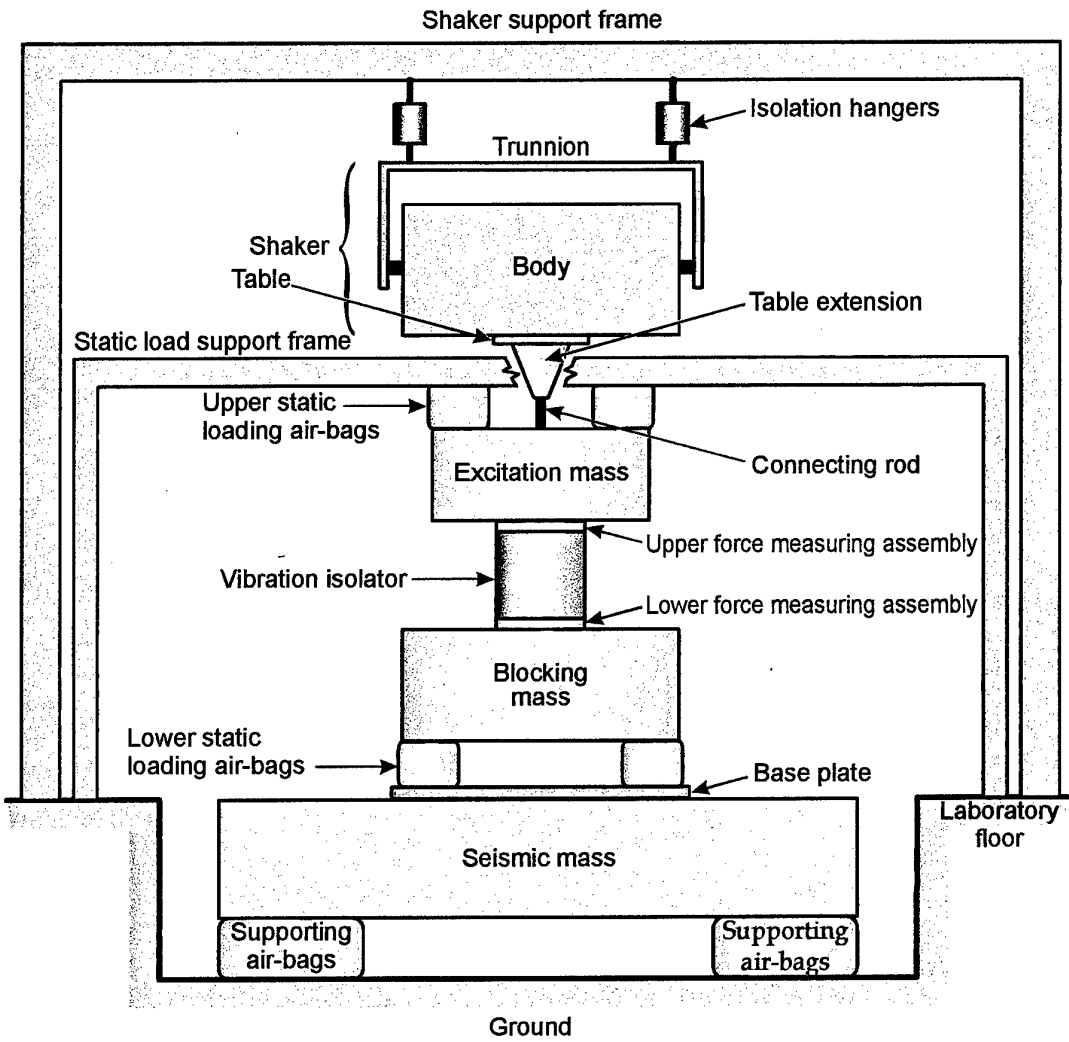

Figure 6 Schematic diagram of vibration isolator test rig.

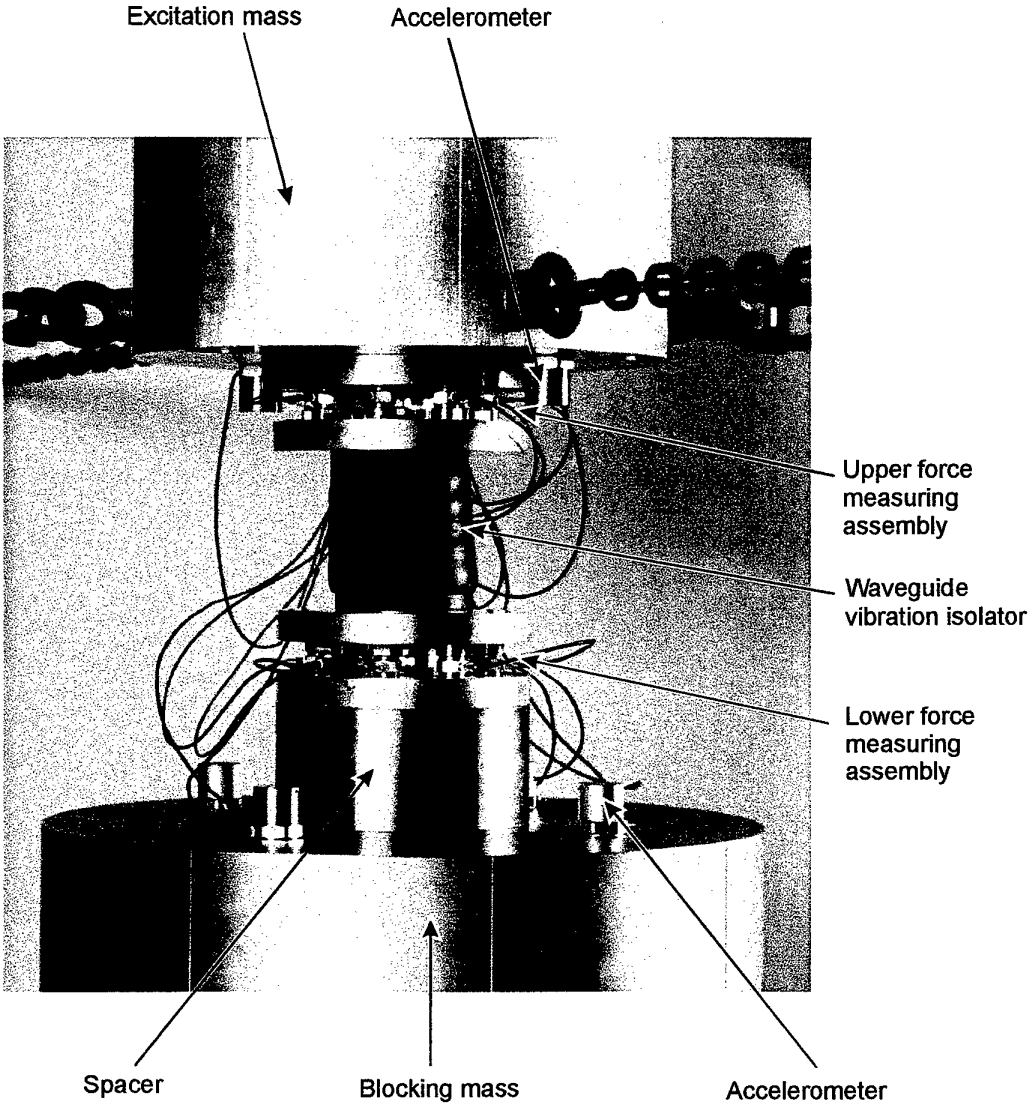

Figure 7 Waveguide vibration isolator under test at compression ratio of 0.90.

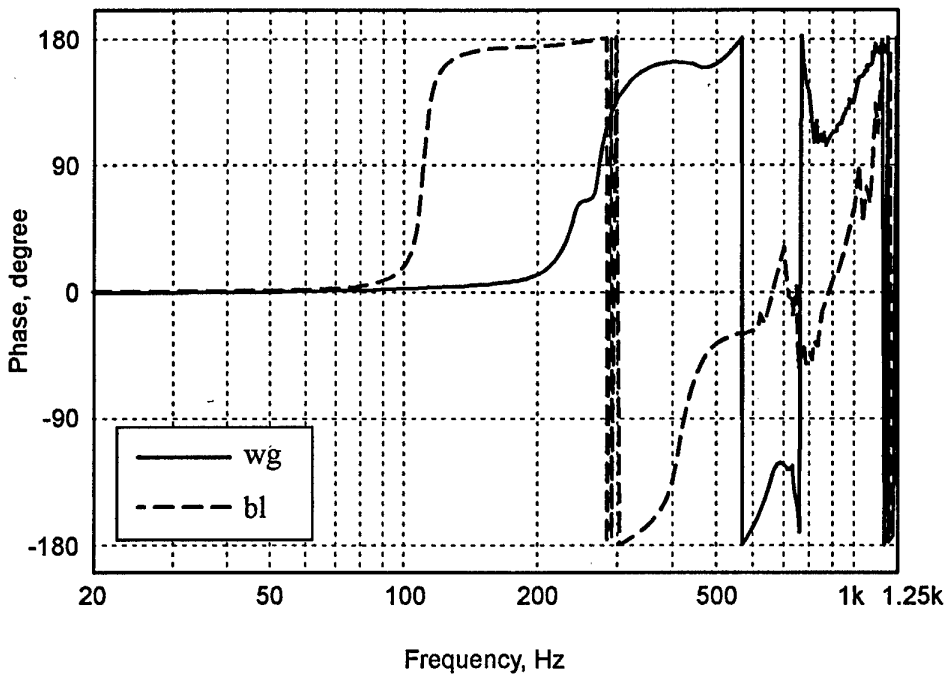
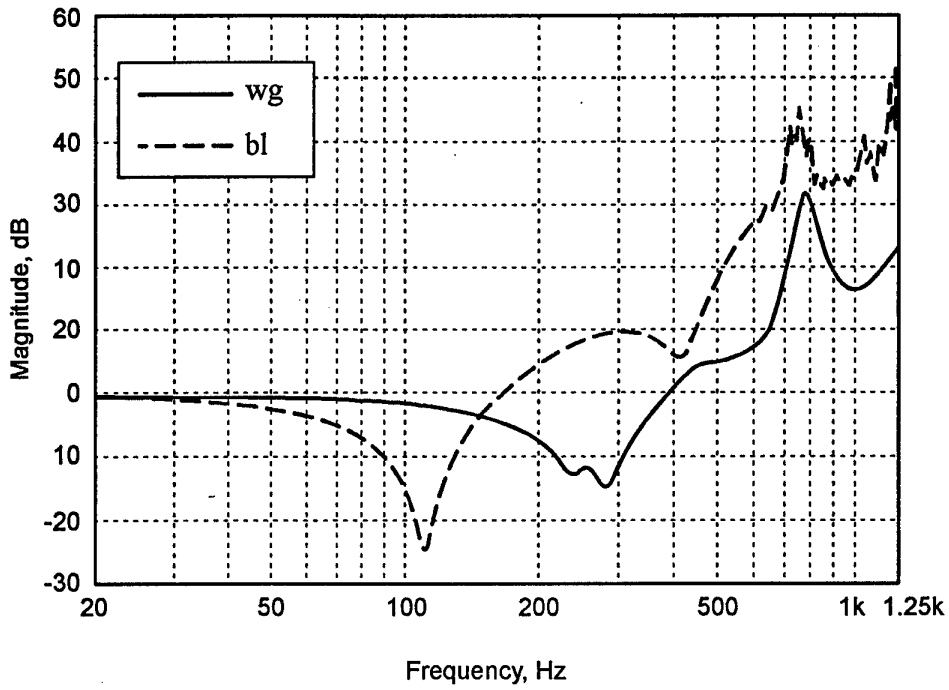

Figure 8 Four-pole parameter α_{11}^* for configuration 1 at compression ratio of 0.95.

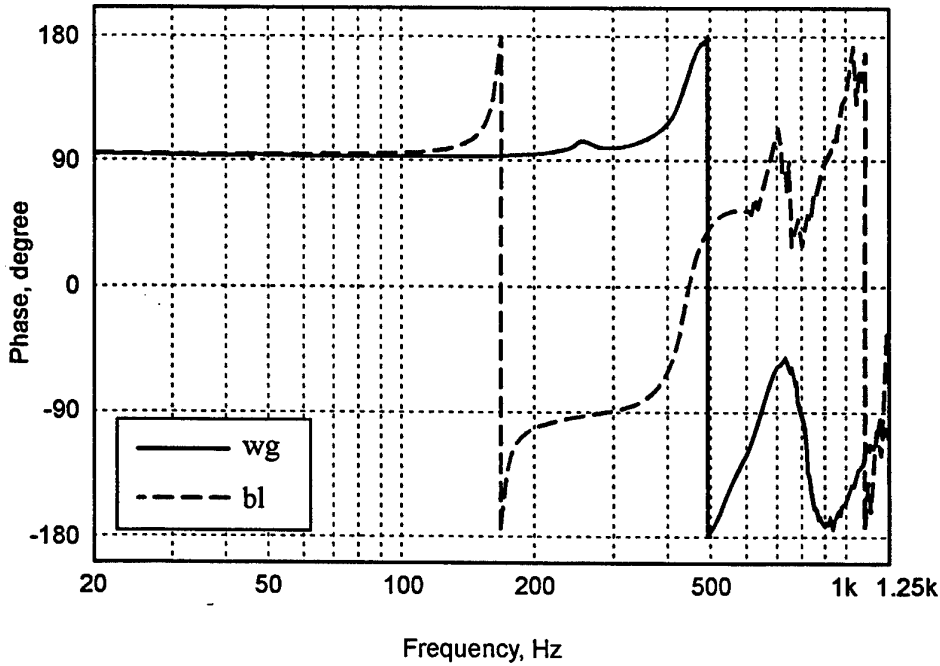
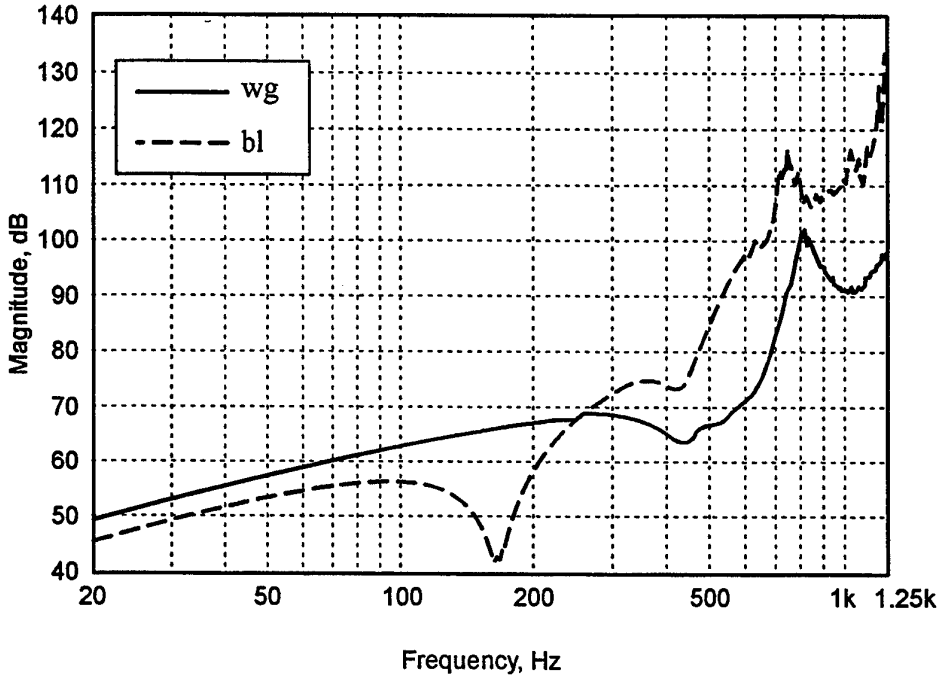

Figure 9 Four-pole parameter α_{12}^* for configuration 1 at compression ratio of 0.95.

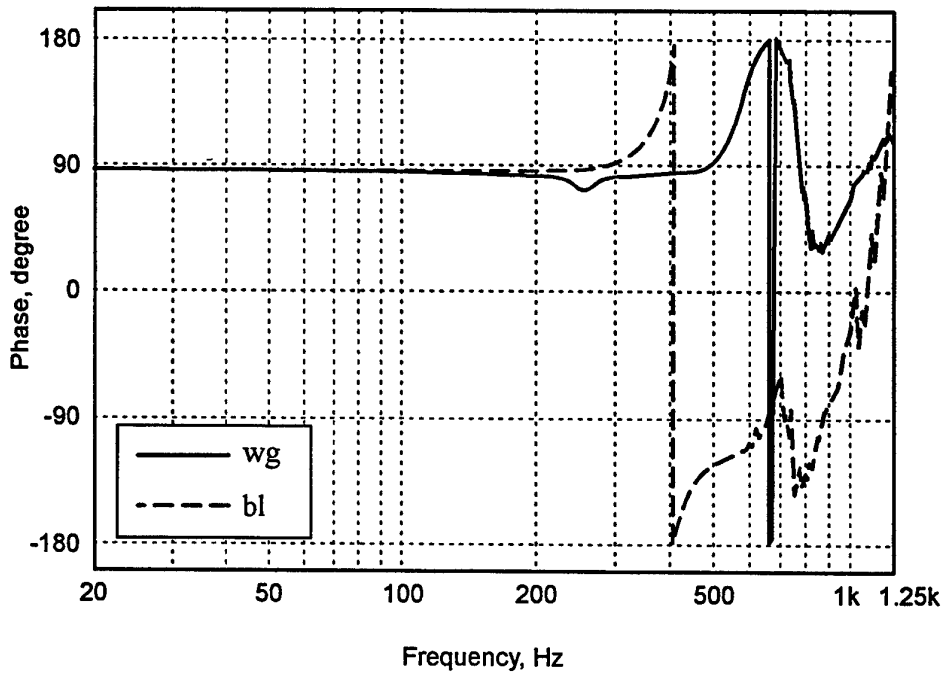
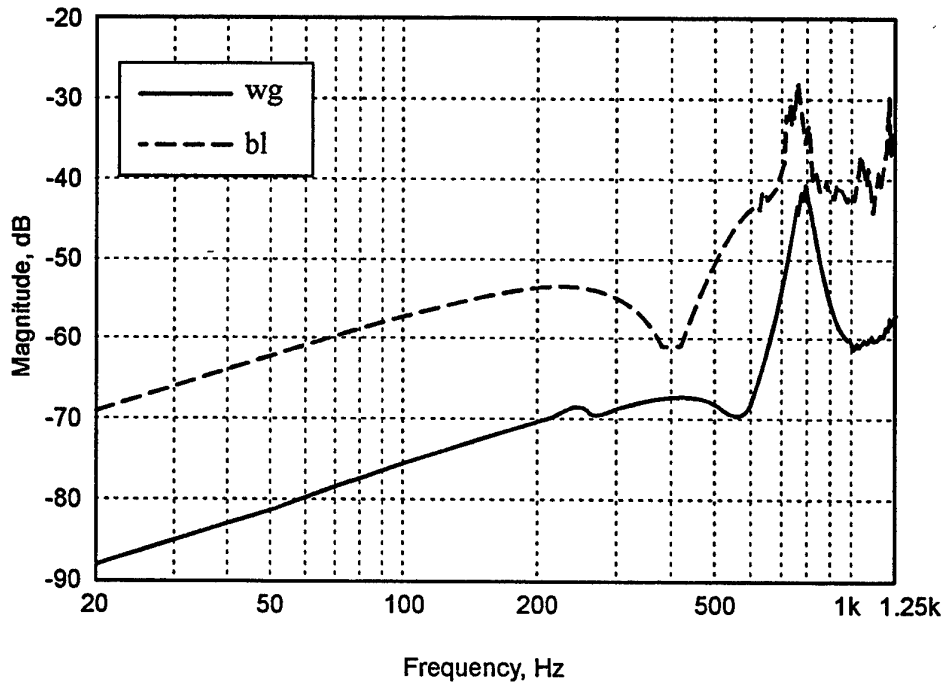

Figure 10 Four-pole parameter α_{21}^* for configuration 1 at compression ratio of 0.95.

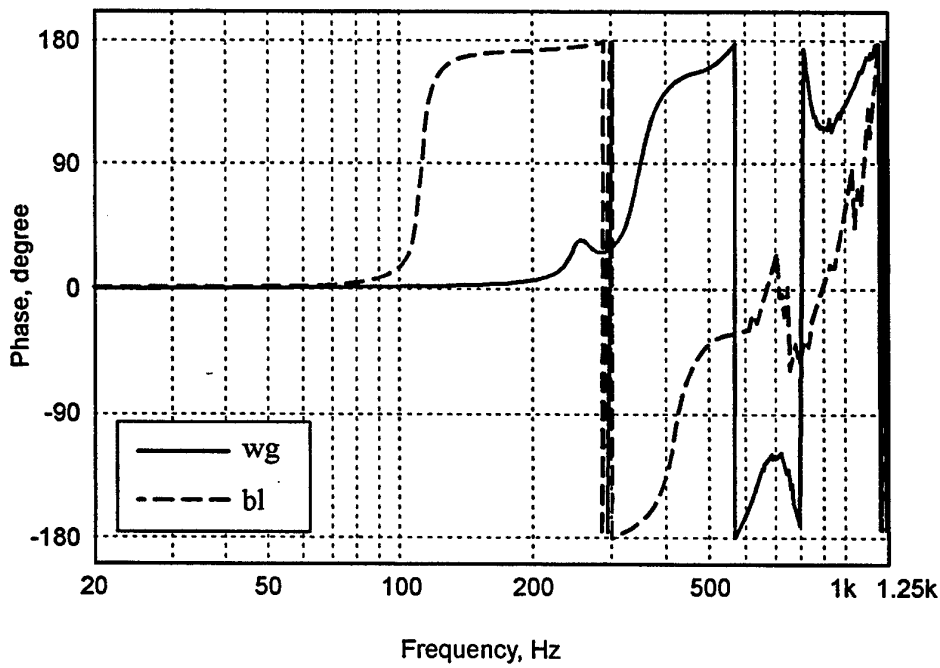
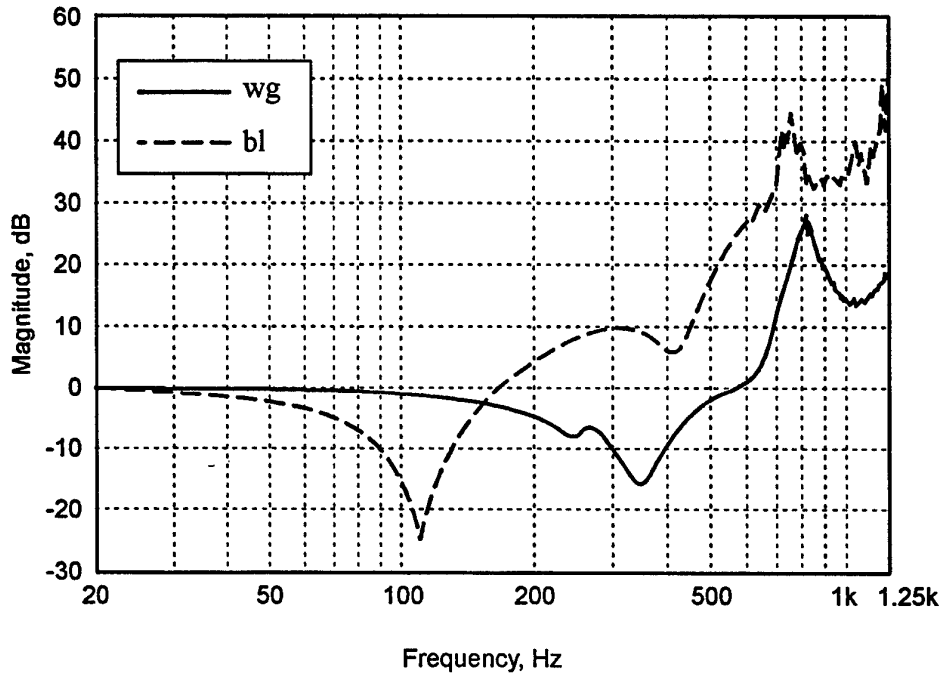

Figure 11 Four-pole parameter α_z^* for configuration 1 at compression ratio of 0.95.

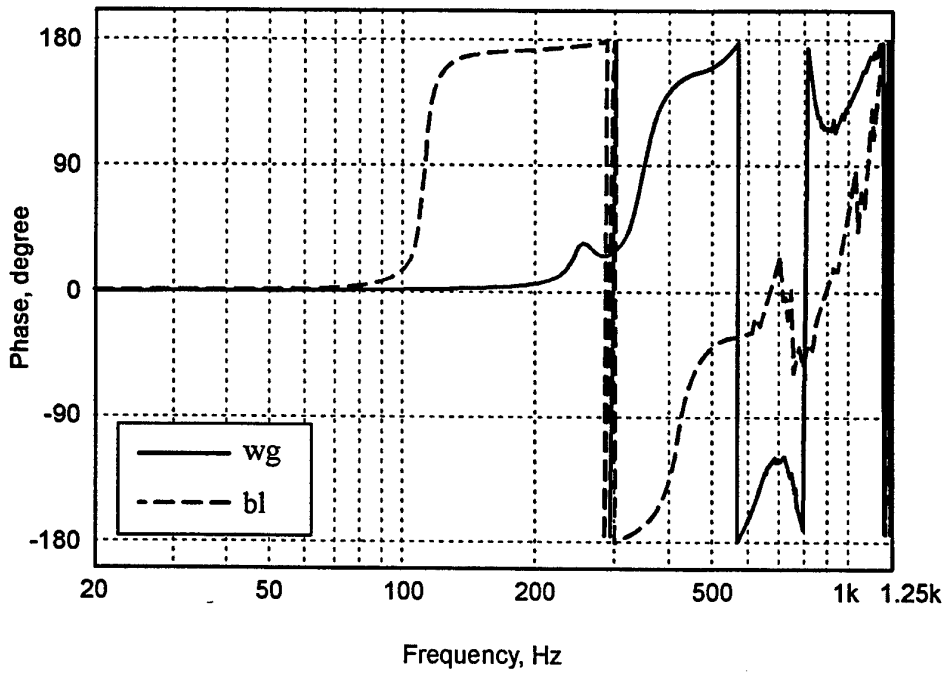
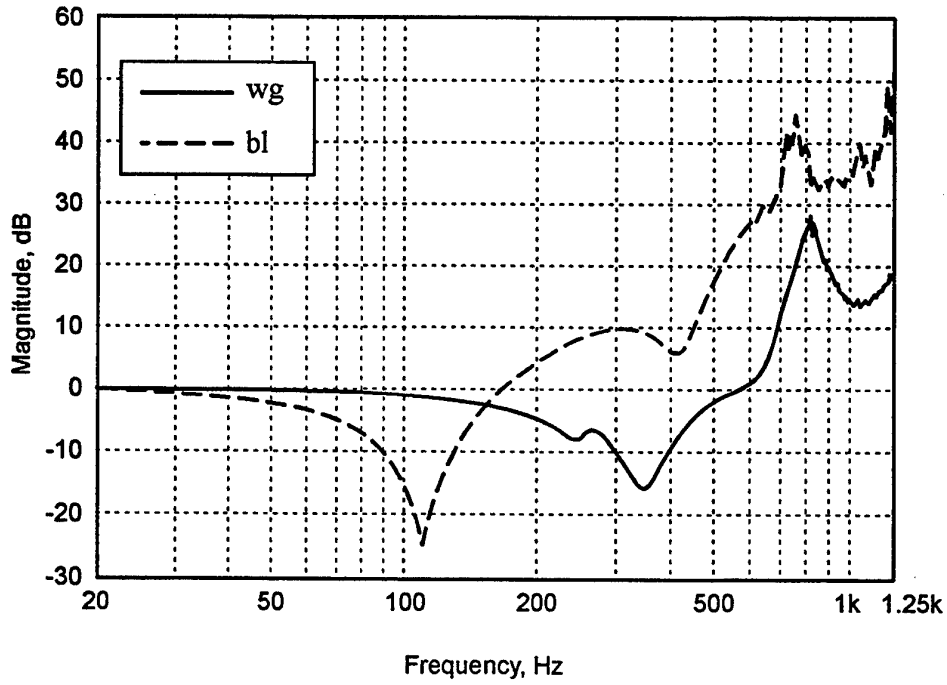

Figure 12 Four-pole parameter α_{11} * for configuration 2 at compression ratio of 0.95.

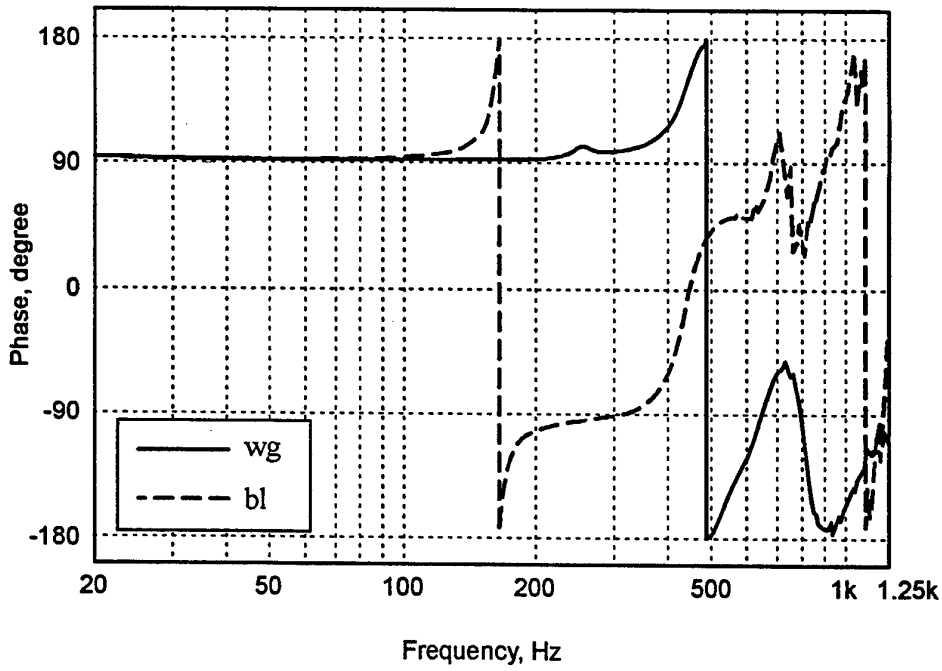
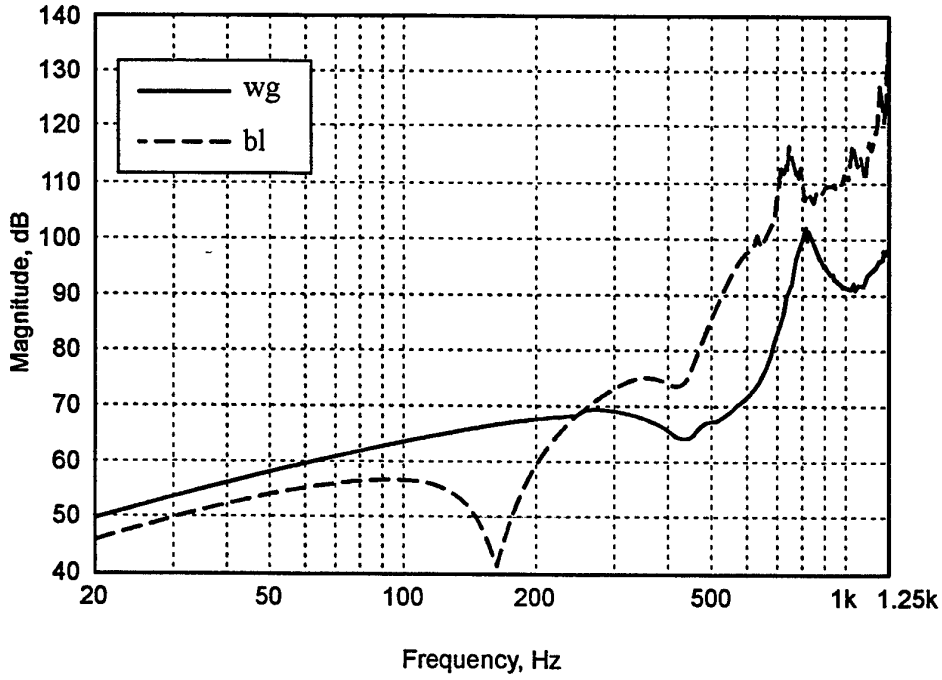

Figure 13 Four-pole parameter α_{12}^* for configuration 2 at compression ratio of 0.95.

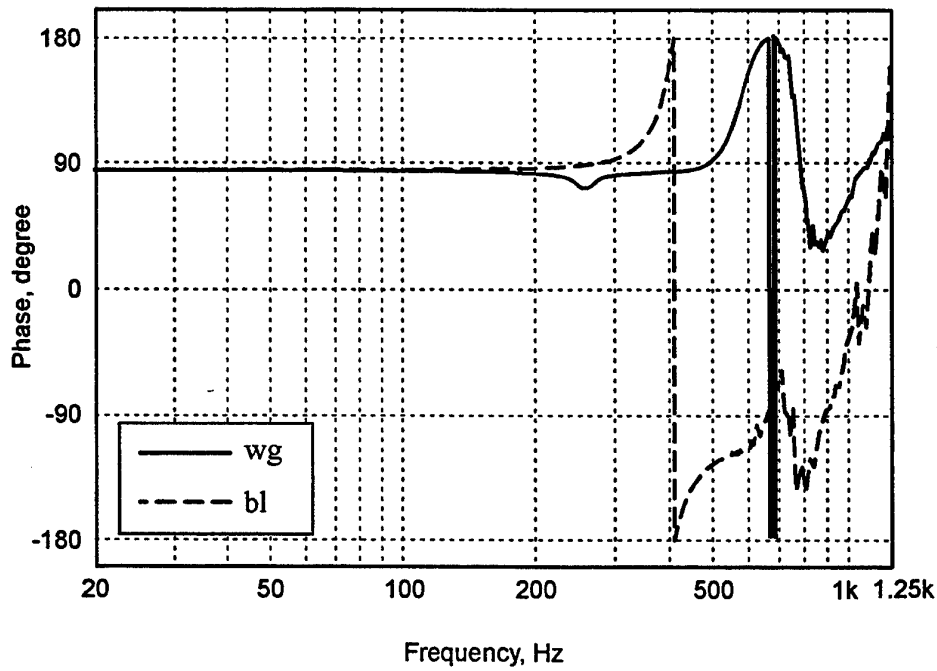
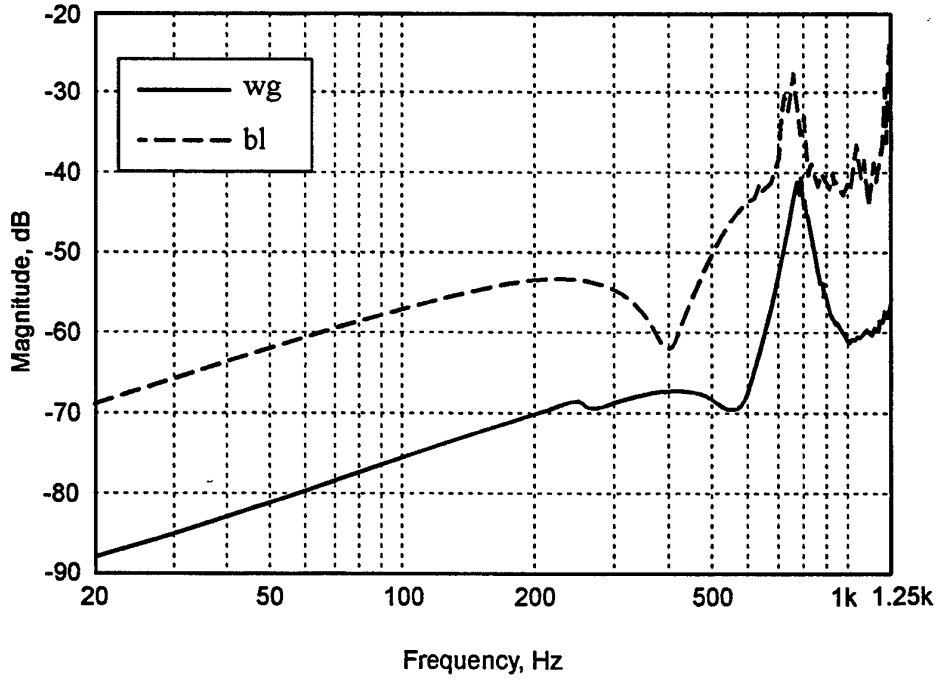

Figure 14 Four-pole parameter α_{21}^* for configuration 2 at compression ratio of 0.95.

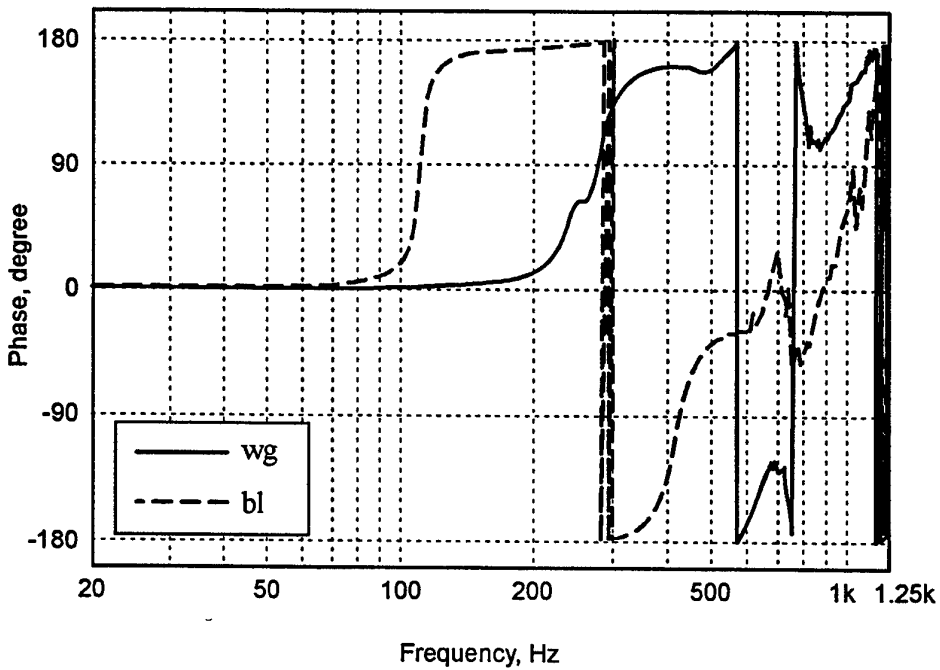
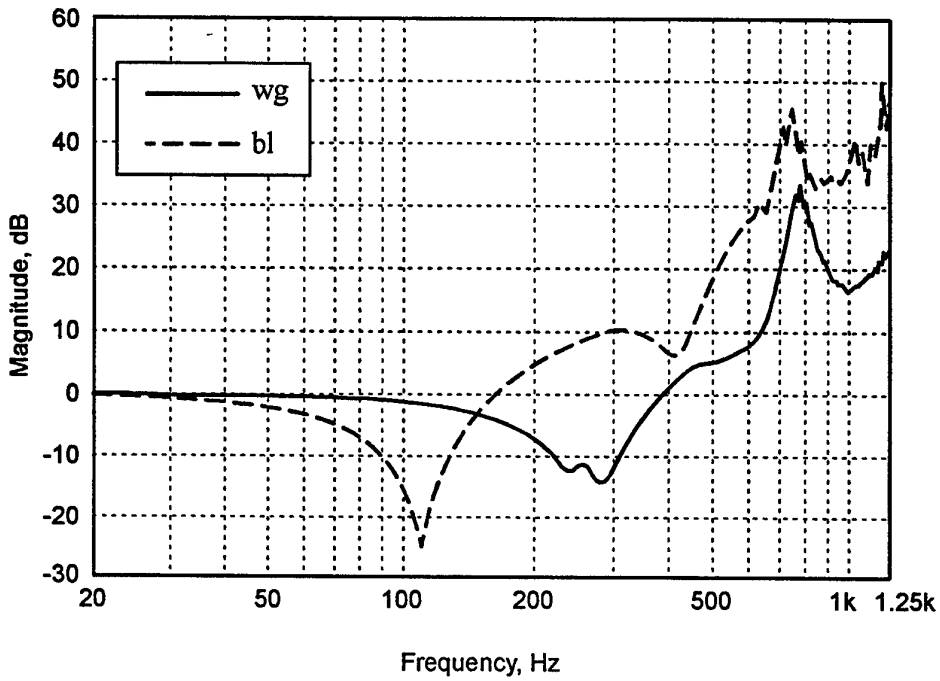

Figure 15 Four-pole parameter α_{z2}^* for configuration 2 at compression ratio of 0.95.

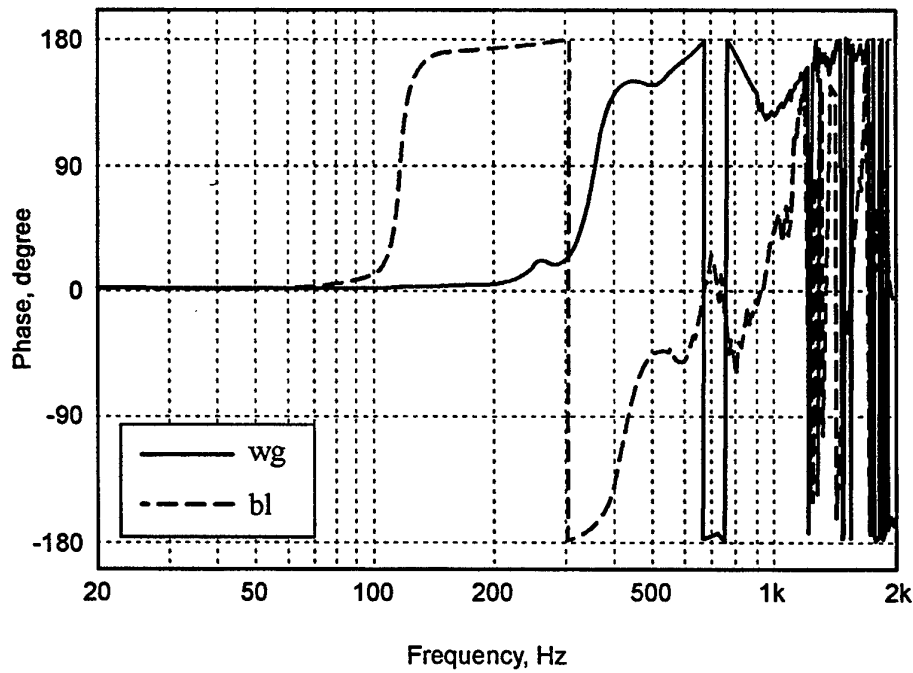
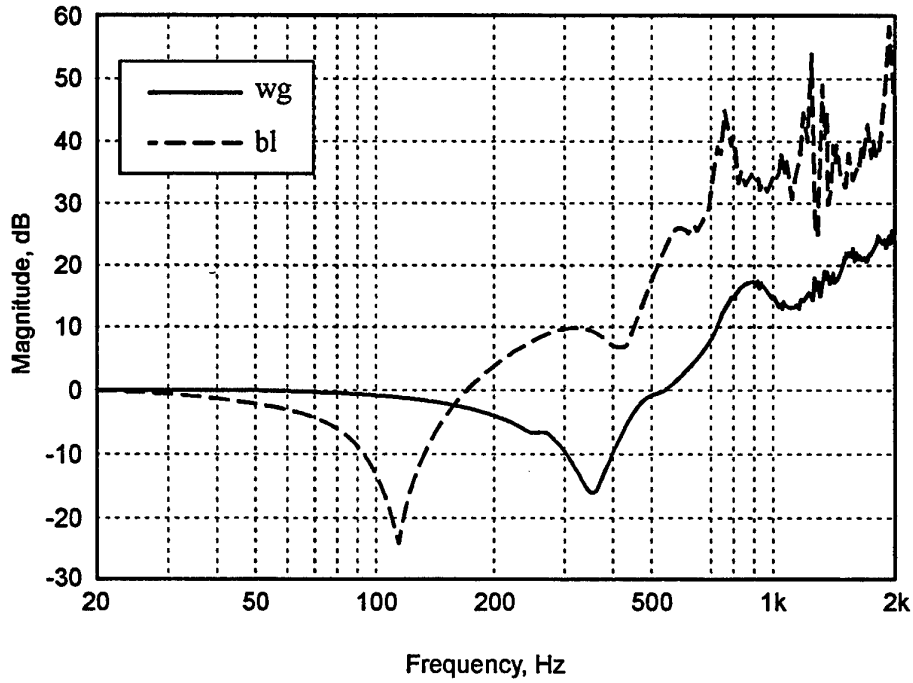

Figure 16 Four-pole parameter α_{11}^* for configuration 1 at compression ratio of 0.90.

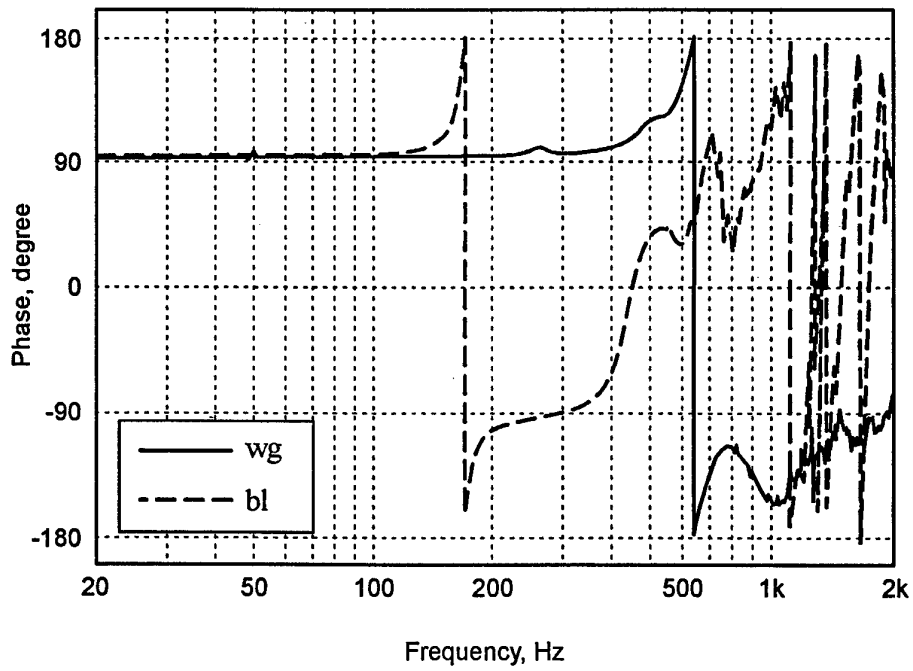
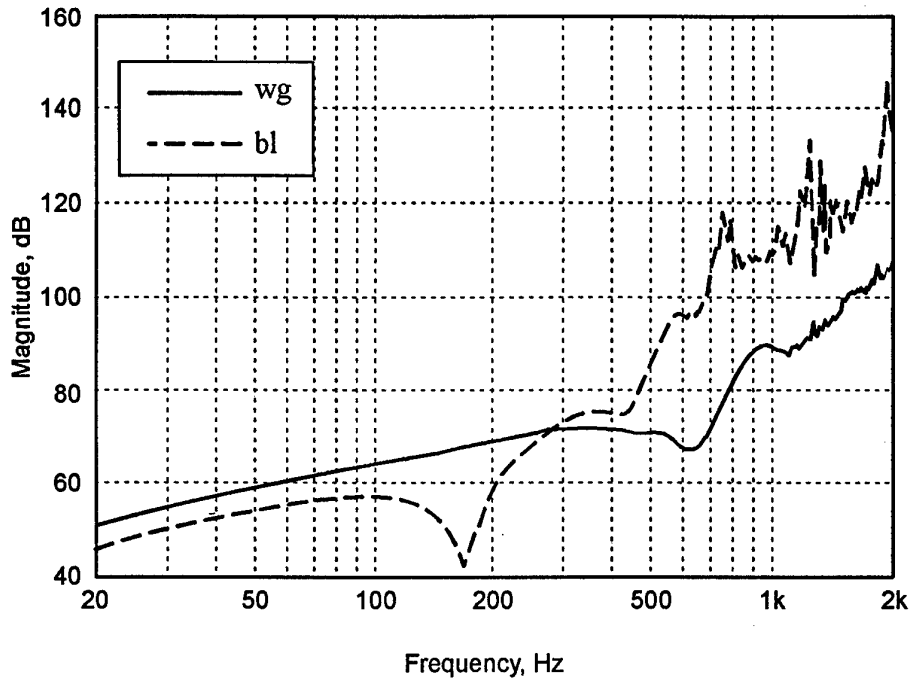

Figure 17 Four-pole parameter α_n^* for configuration 1 at compression ratio of 0.90.

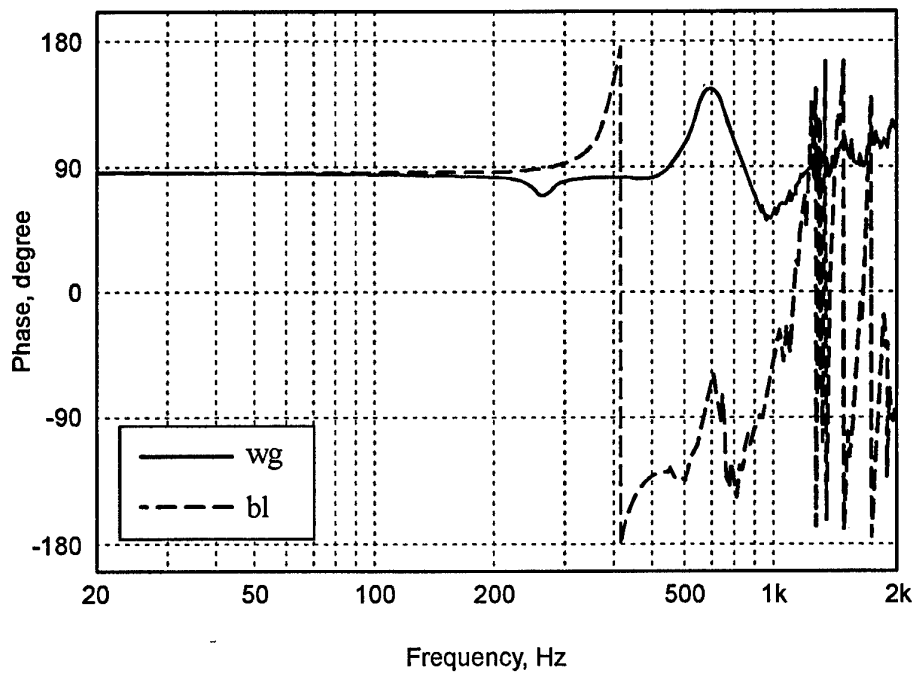
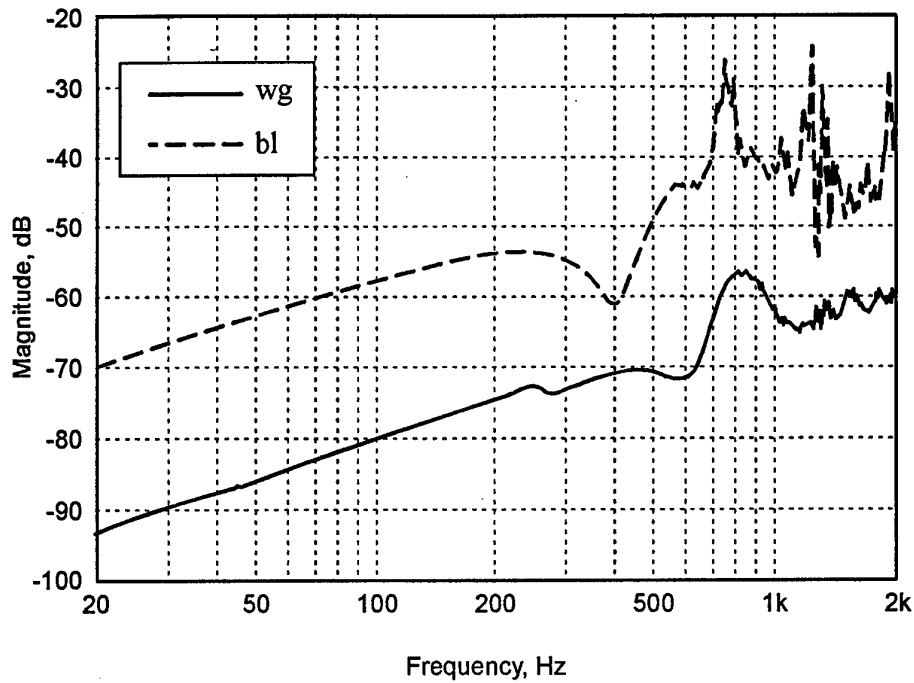

Figure 18 Four-pole parameter α_{z1}^* for configuration 1 at compression ratio of 0.90.

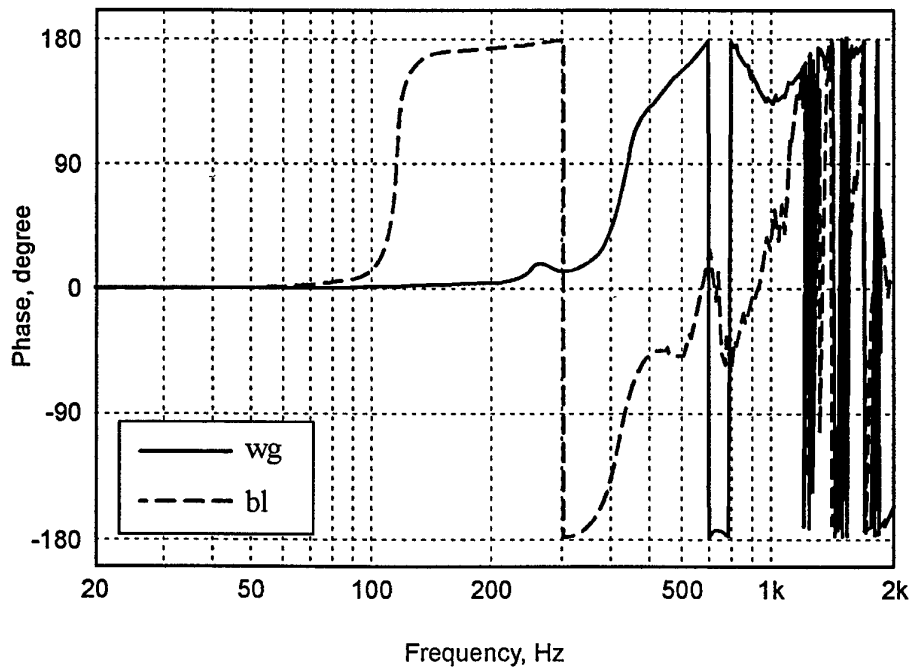
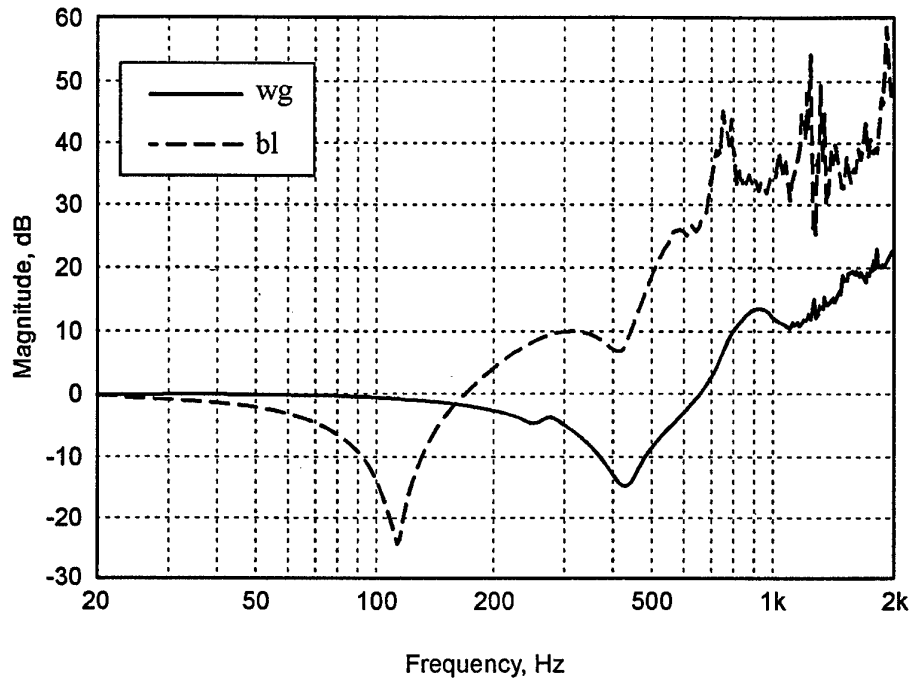

Figure 19 Four-pole parameter α_{22}^* for configuration 1 at compression ratio of 0.90.

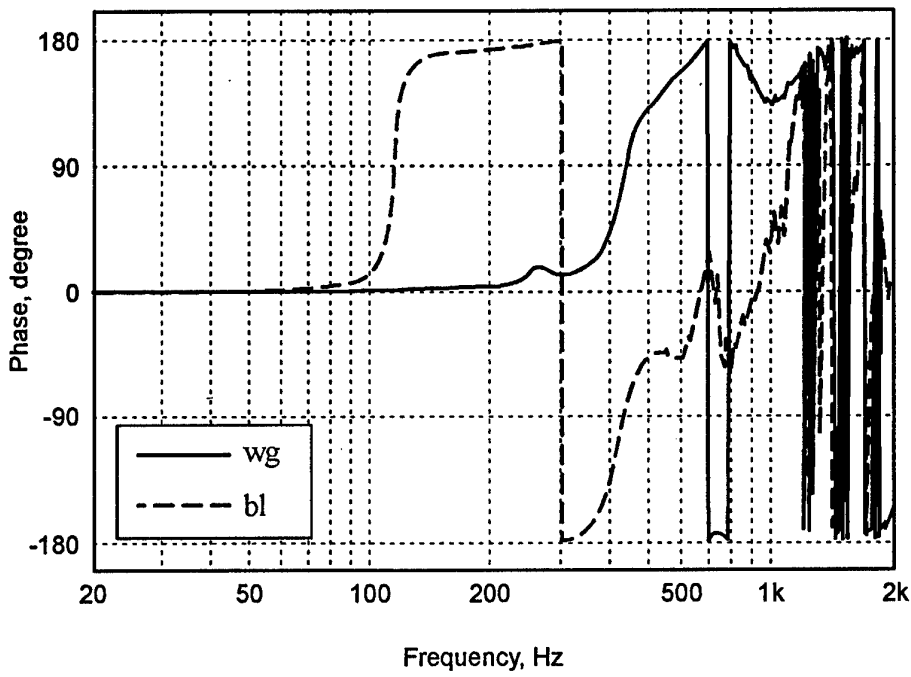
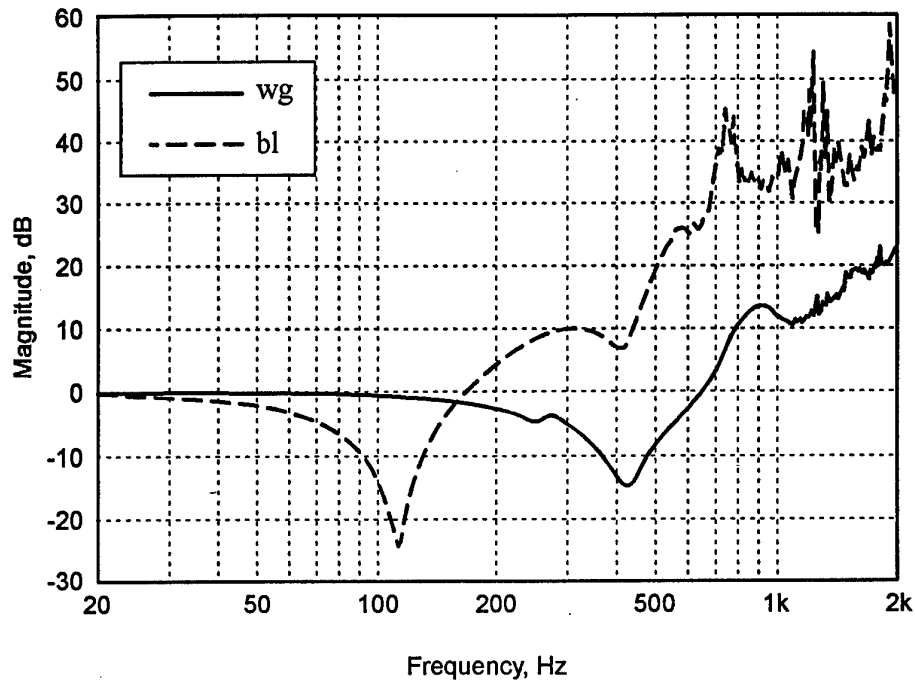

Figure 20 Four-pole parameter α_{11}^* for configuration 2 at compression ratio of 0.90.

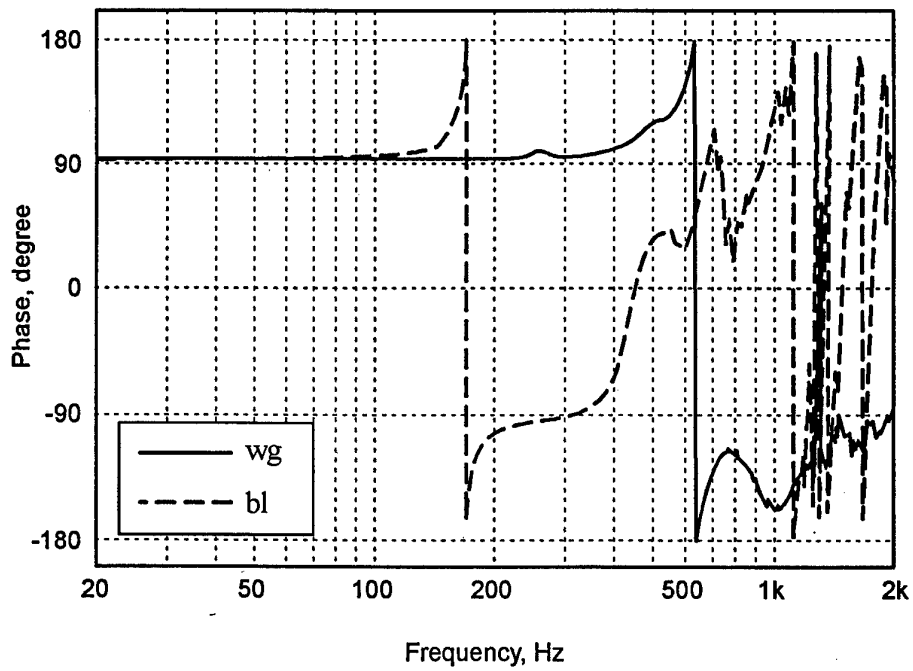
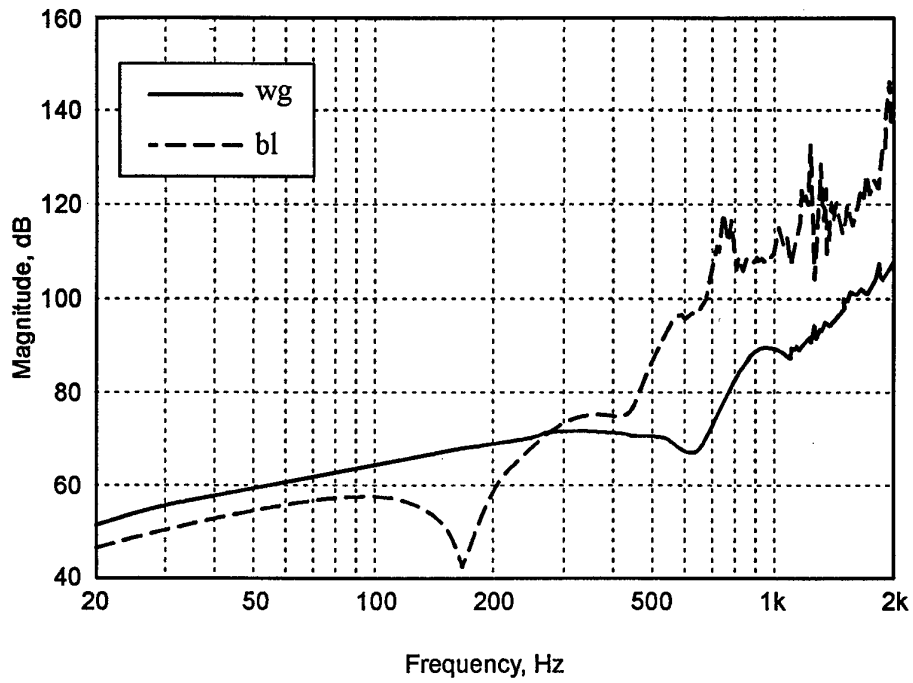

Figure 21 Four-pole parameter α_{12}^* for configuration 2 at compression ratio of 0.90.

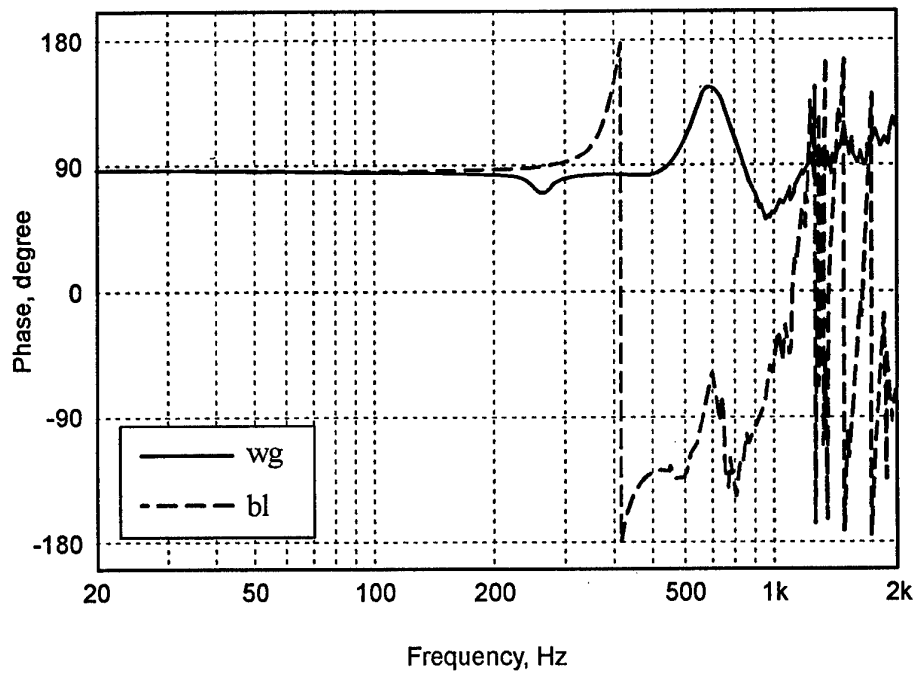
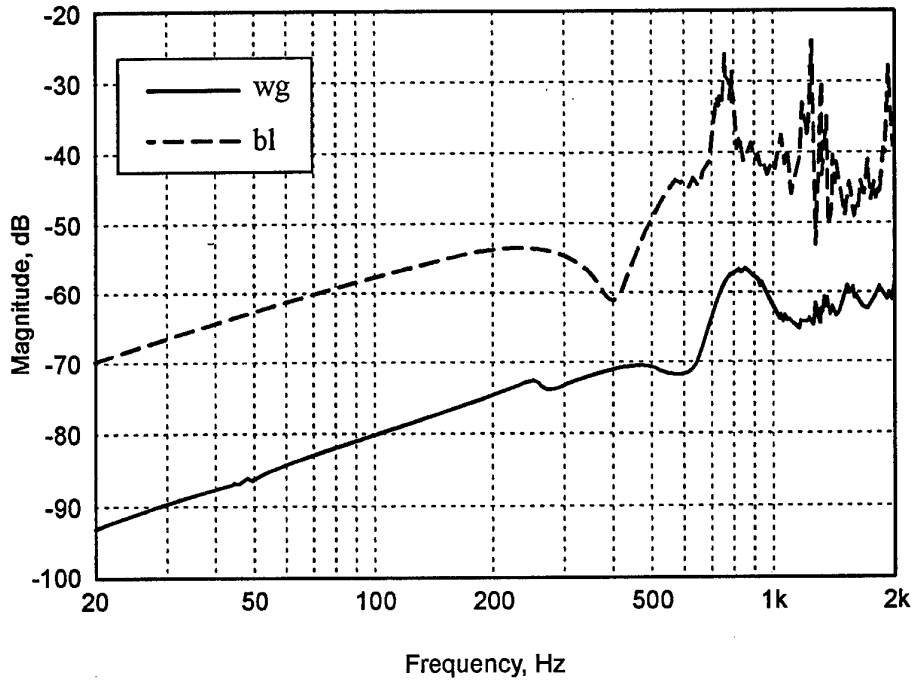

Figure 22 Four-pole parameter α_{21}^* for configuration 2 at compression ratio of 0.90.

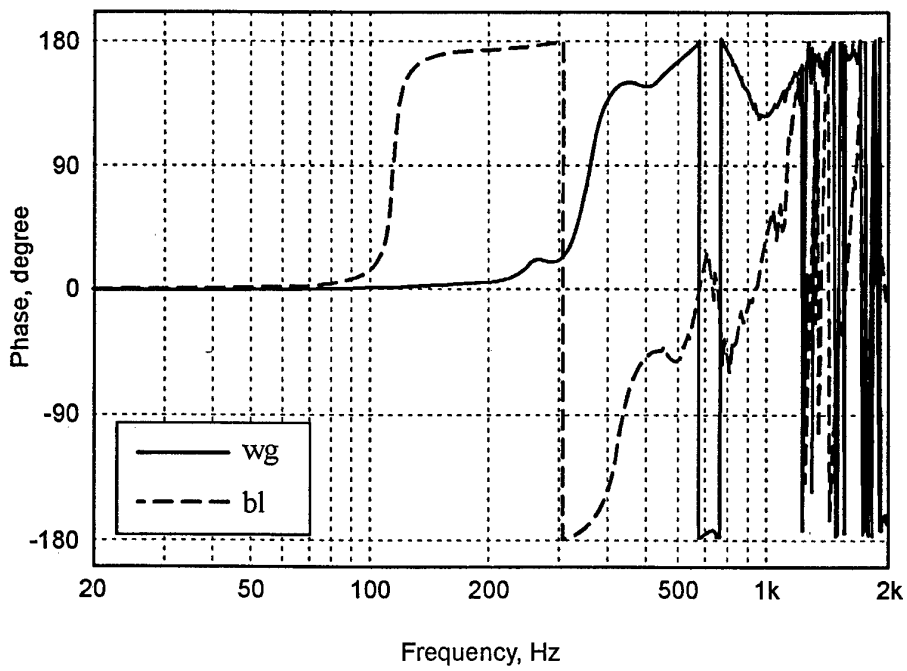
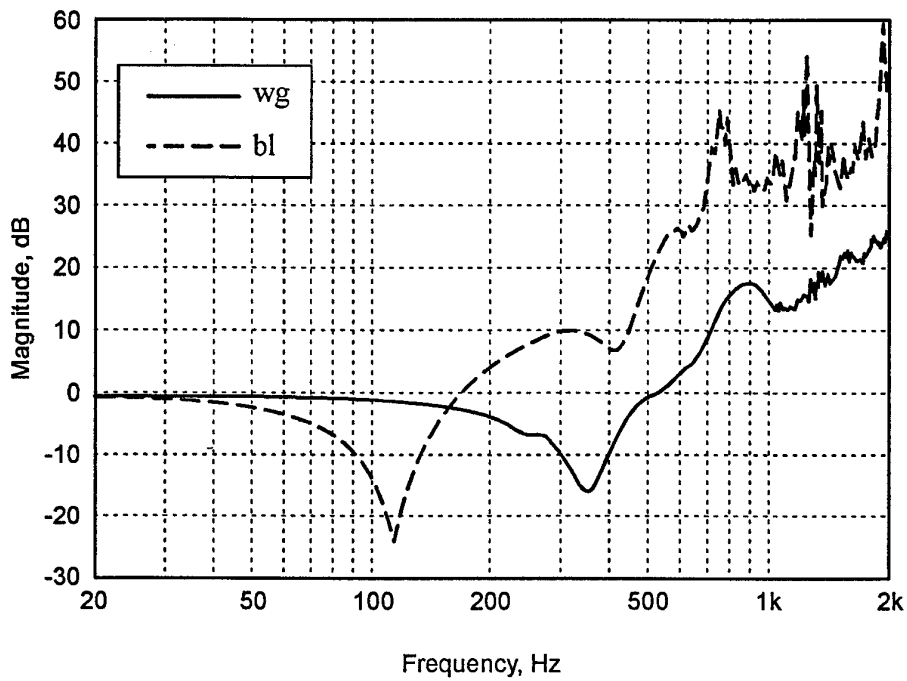

Figure 23 Four-pole parameter α_{22}^* for configuration 2 at compression ratio of 0.90.

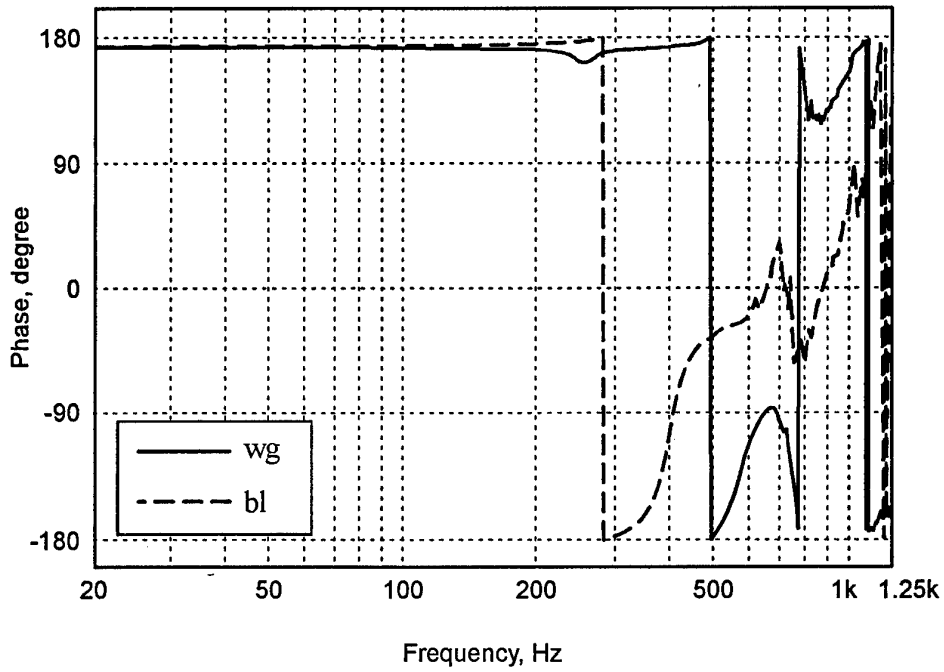
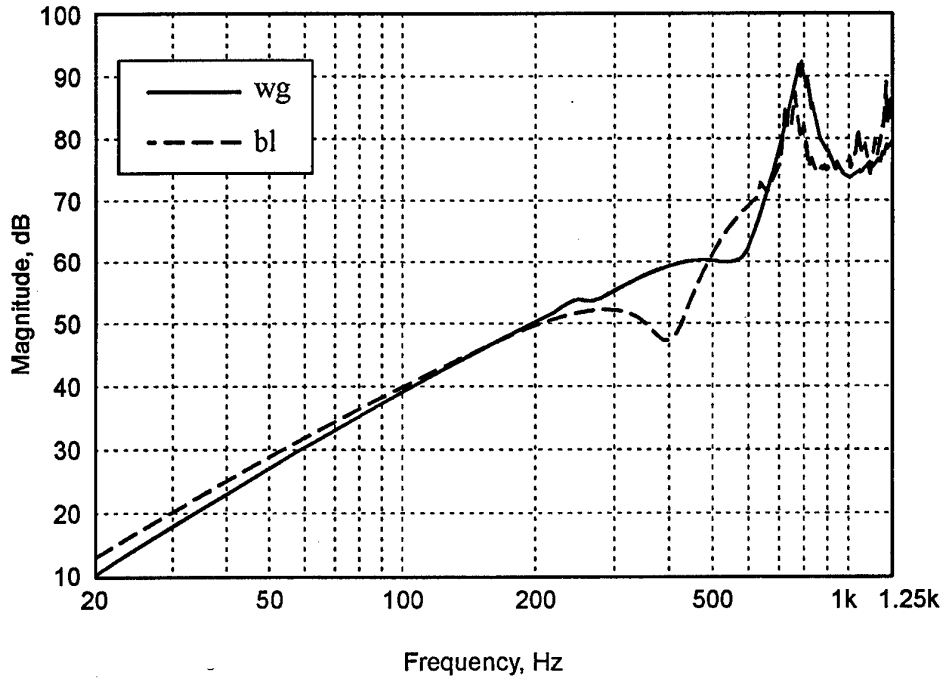

Figure 24 Effectiveness of vibration isolator, configuration 1 at compression ratio of 0.95.

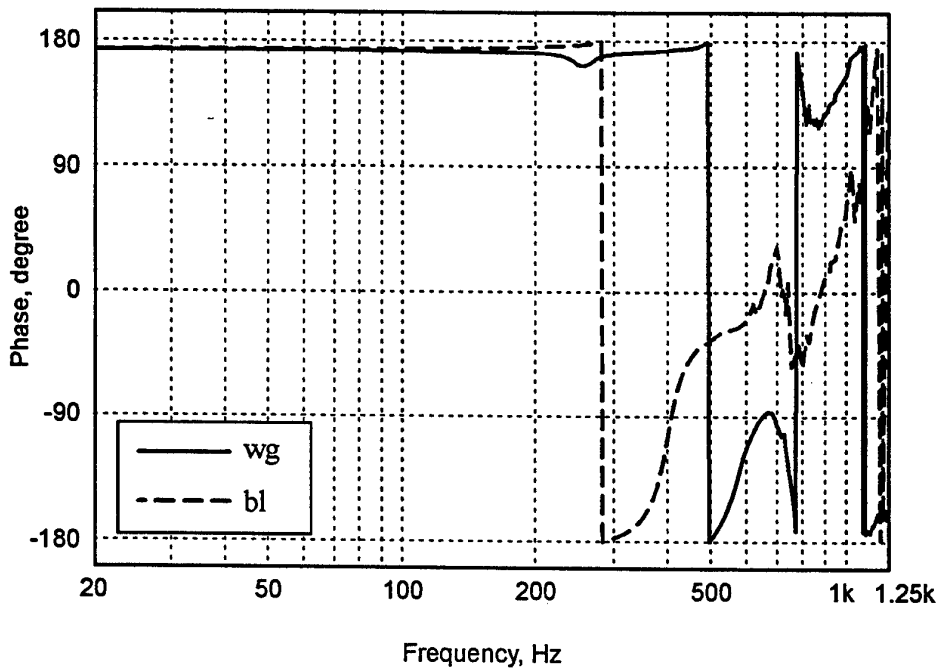
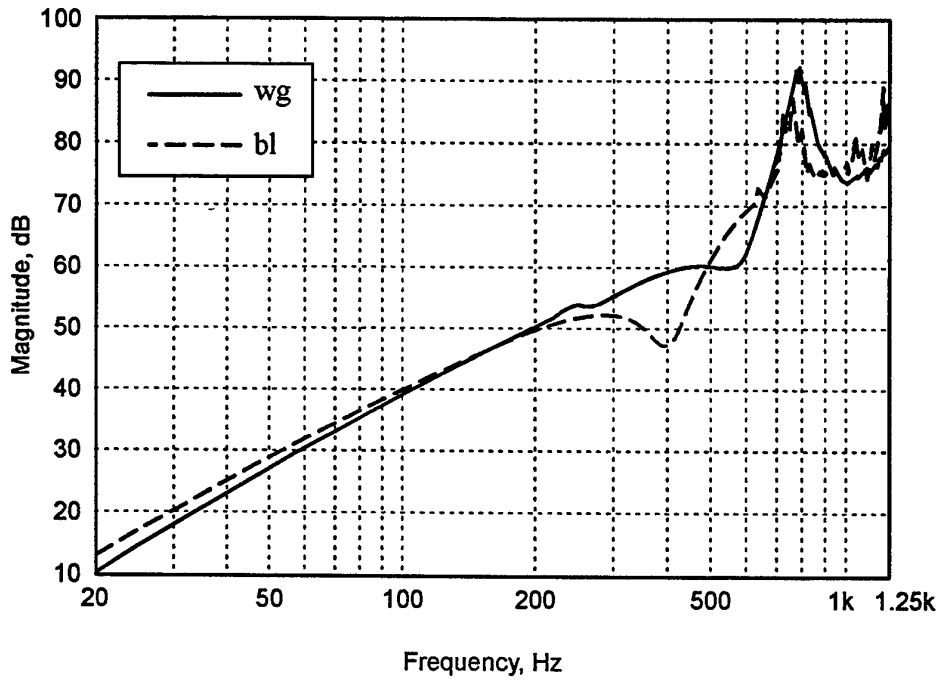

Figure 25 Effectiveness of vibration isolator, configuration 2 at compression ratio of 0.95.

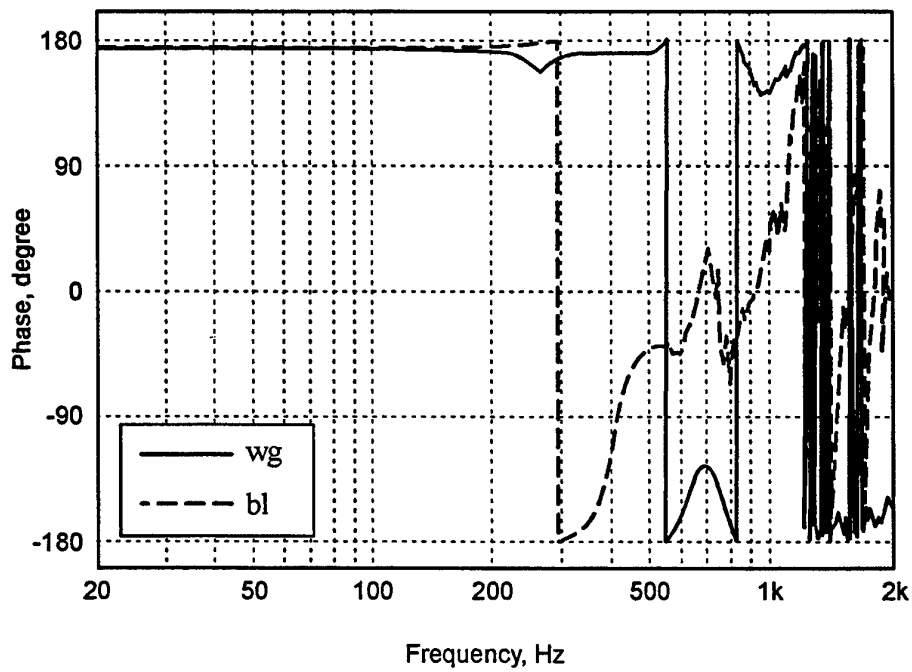
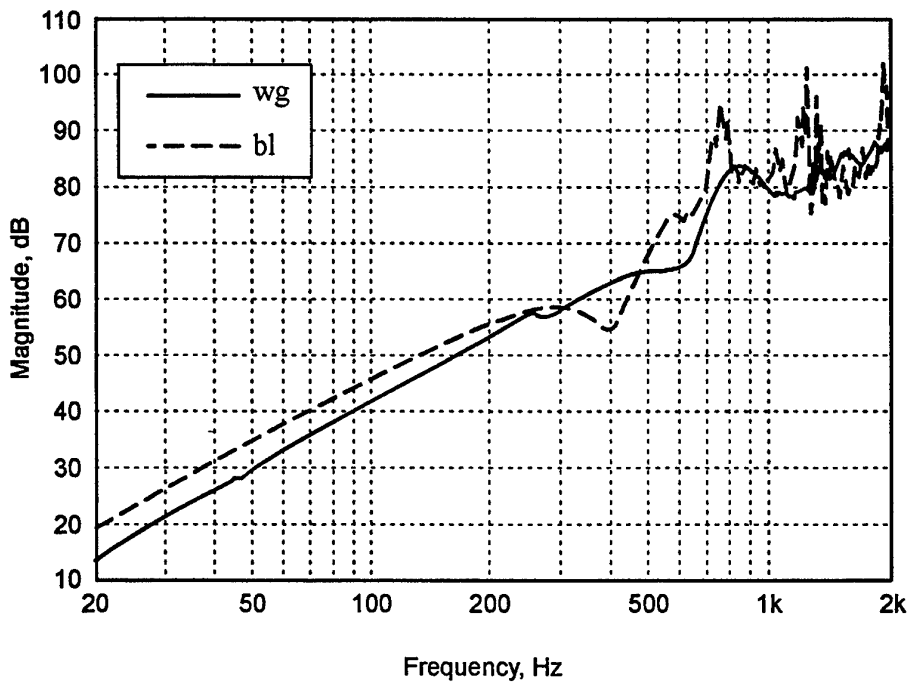

Figure 26 Effectiveness of vibration isolator, configuration 1 at compression ratio of 0.90.

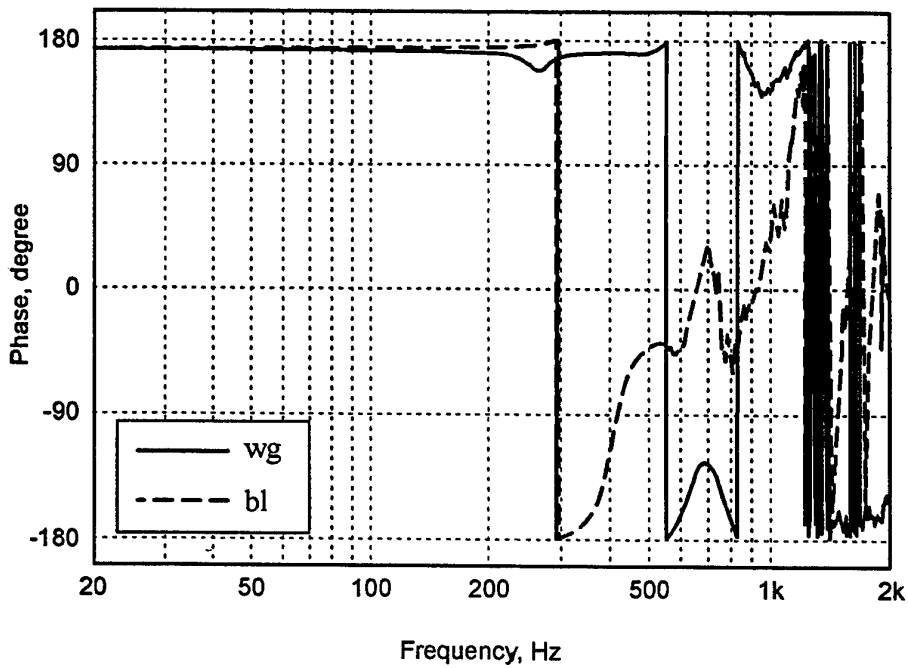
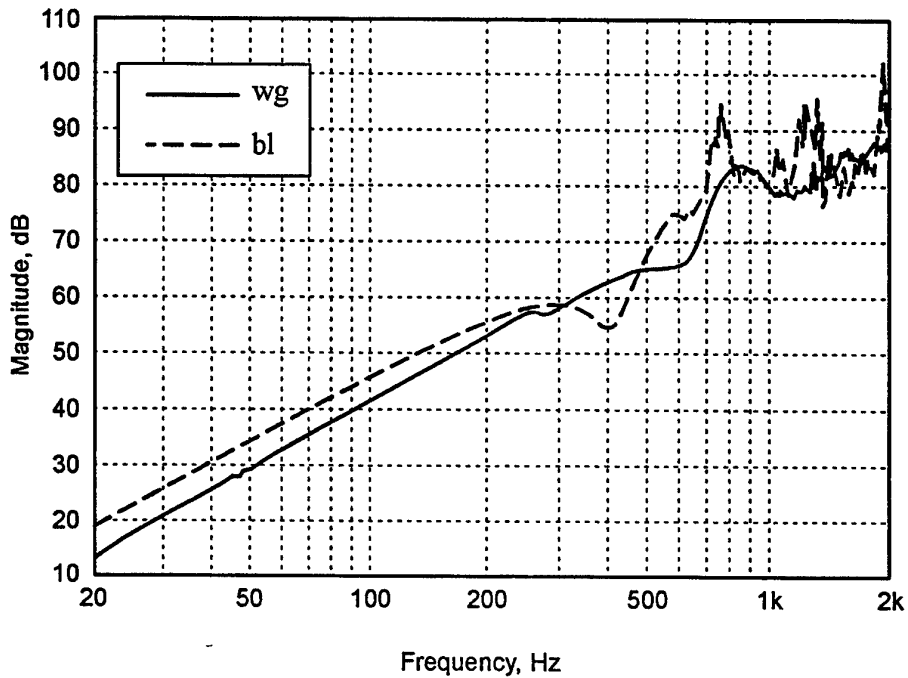

Figure 27 Effectiveness of vibration isolator, configuration 2 at compression ratio of 0.90.

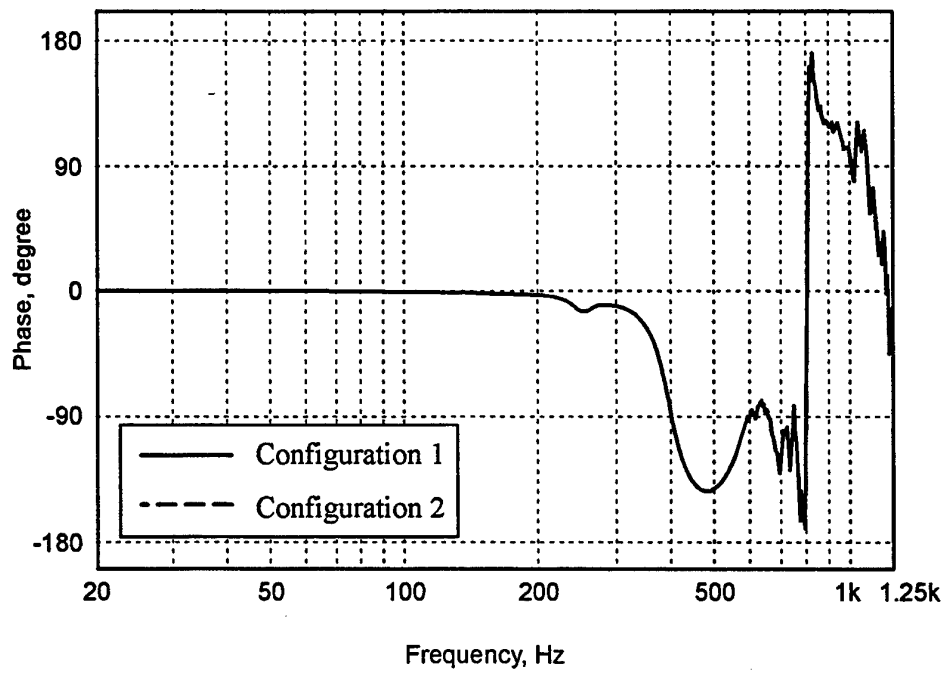
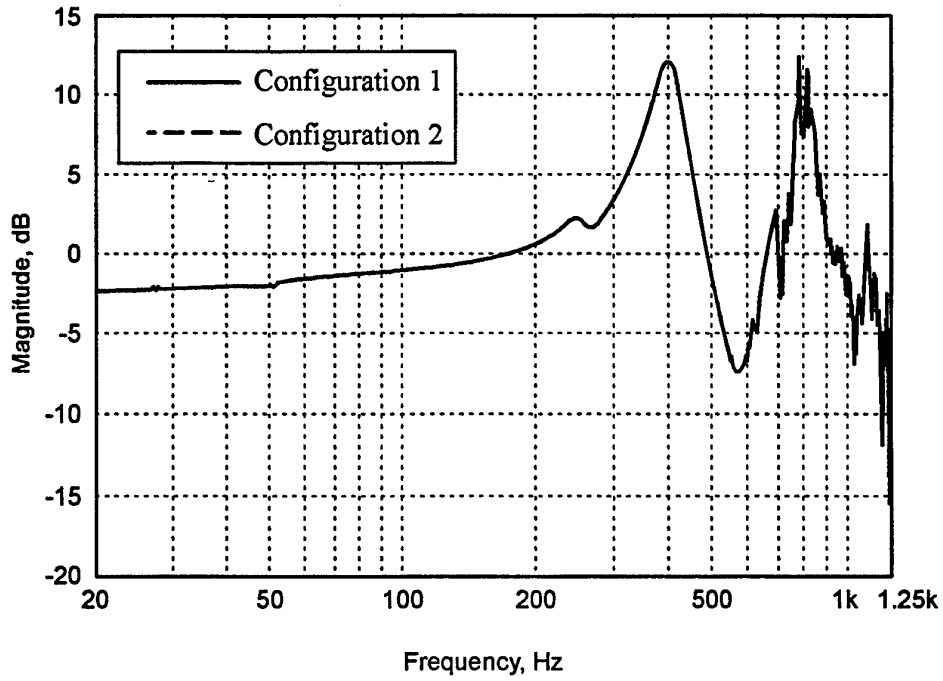

Figure 28 Effectiveness change, for compression ratio of 0.95.

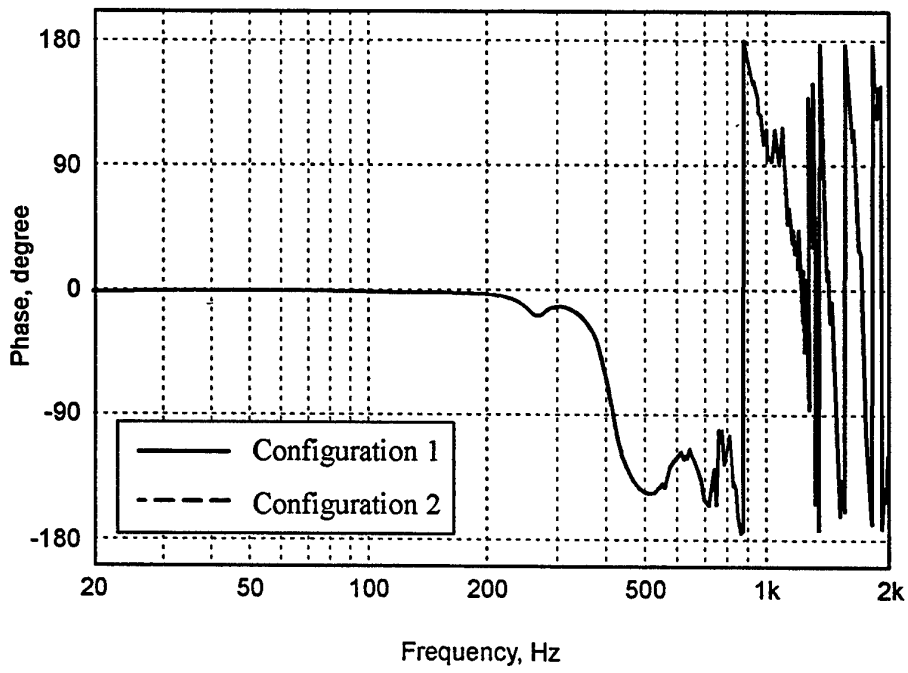
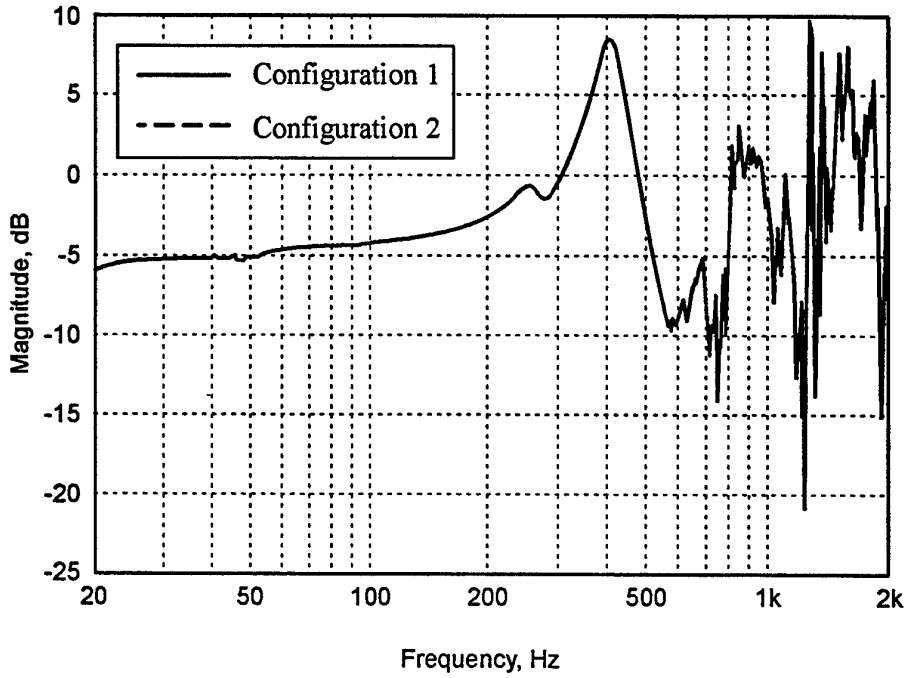

Figure 29 Effectiveness change, for compression ratio of 0.90.

Appendix A: Physical properties of vibration isolators

Drawings of the waveguide and blank vibration isolators are shown in Figures A1 and A2. The rubber was a natural rubber vulcanisate reinforced with carbon black. For each vibration isolator the diameter of the end plates D, height of the vibration isolator H, mass of the vibration isolator, and rubber hardness RH are given in Table A1.

Table A1: Physical measurements of vibration isolators

Vibration isolator	D (mm)	H (mm)	Mass (kg)	RH (IRHD)
Waveguide	91.9	115.7	2.442	57
Blank	91.9	117.6	1.916	58

The height was measured after the end plates were ground flat and parallel to each other. The nominal axial distance between the free end of the spring and the adjacent end plate is 6 ± 2 mm.

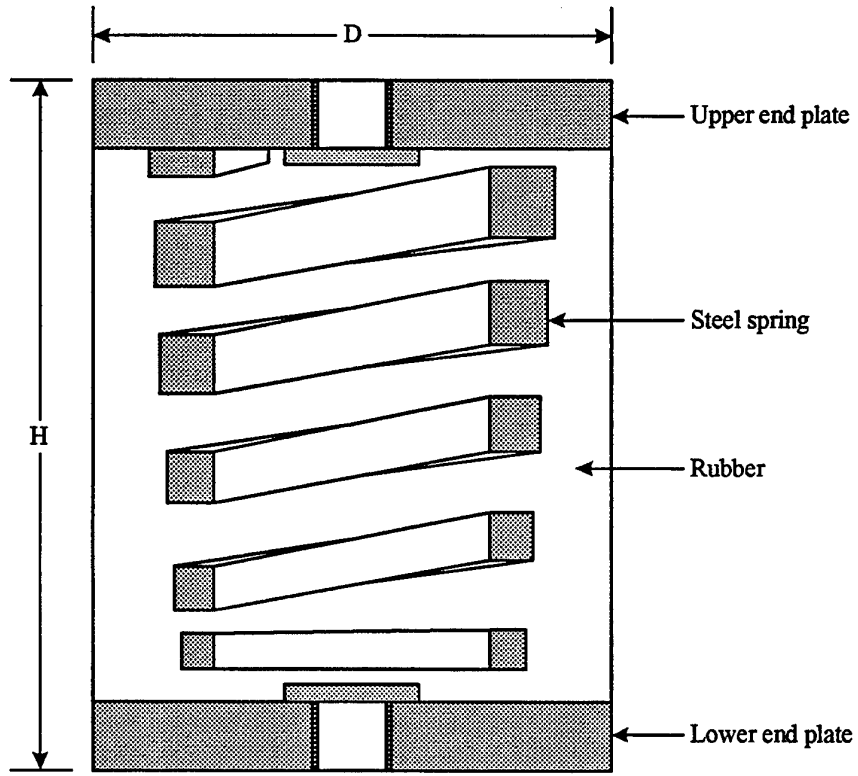

Waveguide vibration isolator

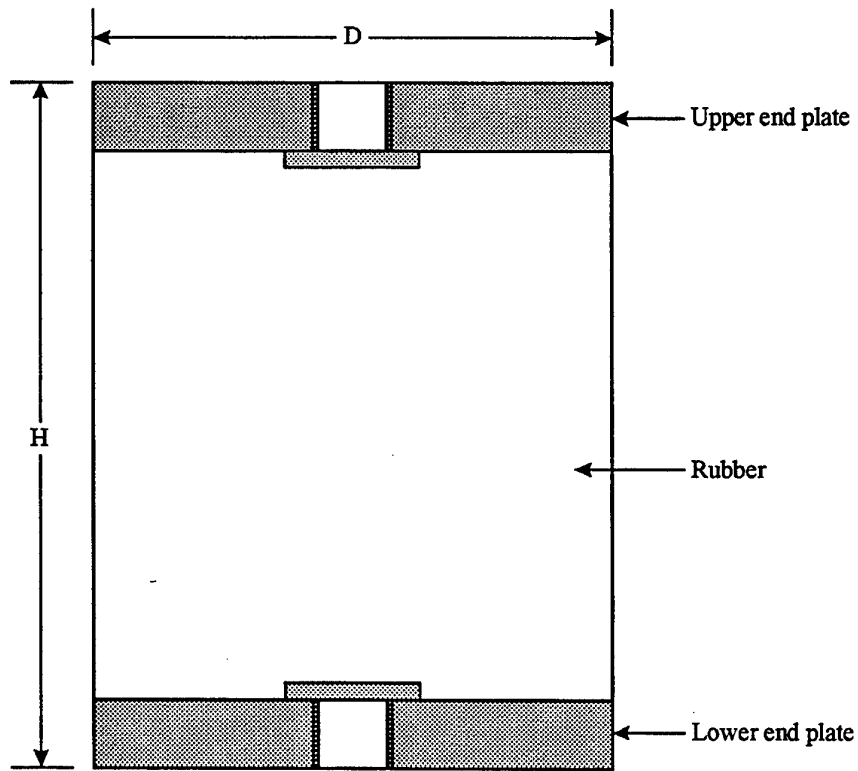

Blank vibration isolator

Figure A1 Sectional drawing of waveguide and blank vibration isolators.

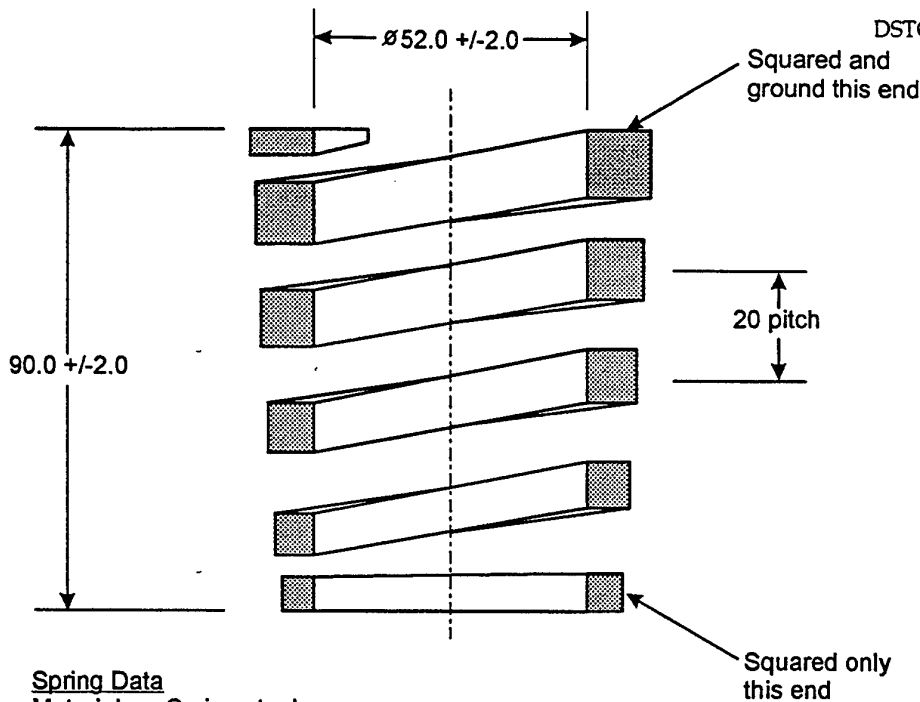

Spring Data

Material: Spring steel
 Shape prior to rolling
 12 mm square at thick end tapering to 6 mm at thin end.
 Length = 1000 mm
 End angle is unimportant.

Hardness: 450-500 HV
 Quantity: 1 off
 Note: No coil is to come closer than 3 mm of any adjacent coil.

24 x 24 x 3 thick
 Mild steel plate,
 continuously welded
 to end plate

Tap M12 through
 Braze one end plate
 to thick end of spring.
 Centres of spring to
 be concentric to within
 $\varnothing 2.0\text{mm}$.

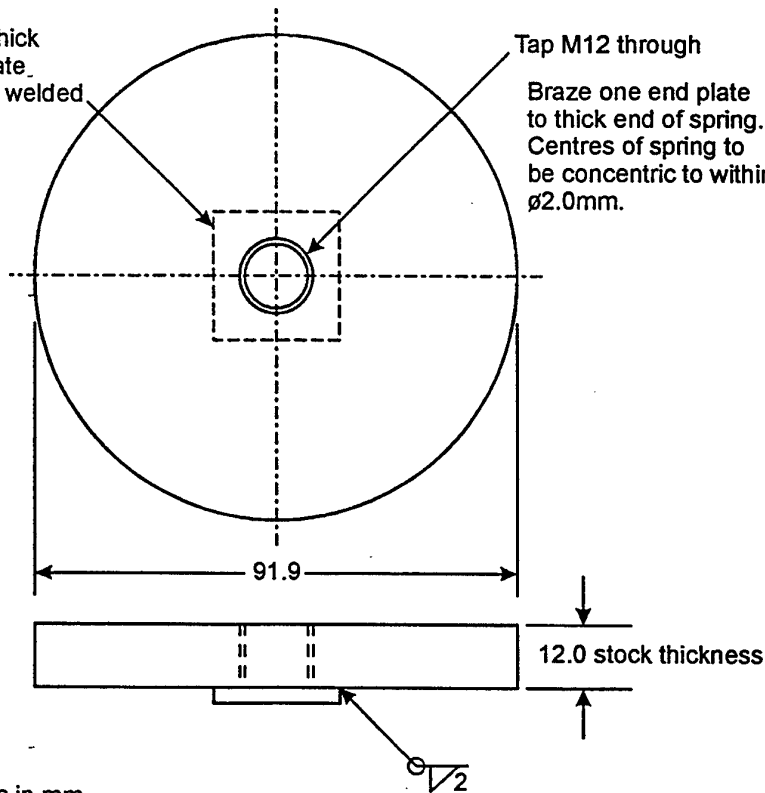

End Plate
 Material: Mild steel
 Quantity: 2 off
 Finish: None

Notes: All dimensions in mm

Figure A2 Steel Components of waveguide vibration isolator.

Appendix B: Dynamic tests on rubber elements

The dynamic stiffnesses and loss factors for the undeformed waveguide and blank vibration isolators were measured by conducting impact tests on the free specimens.

Prior to testing, the rubber elements were conditioned at 14 ± 1 °C for at least 16 hours, and the tests were conducted at the same temperature.

Each vibration isolator was suspended using springs and excited at the centre of one end with an instrumented hammer. The waveguide vibration isolator was excited at the end with the attached spring. The response of the other end was monitored with an accelerometer, which yielded the inertance of the vibration isolator. Analysis of the inertance response function yielded the magnitude of the dynamic stiffness k_D and loss factor at the frequency of the rigid body mode, Table B1.

Table B1: Dynamic complex stiffnesses of vibration isolators

Vibration isolator	Frequency (Hz)	k_D (N/m)	Loss factor
Waveguide	439	3.50×10^6	1.6×10^{-1}
Blank	165	4.57×10^5	9.1×10^{-2}

The steel spring has significantly increased the stiffness and loss factor of the rubber element.

DSTO-TR-0812

Appendix C: Static tests on rubber elements

The secant stiffnesses for the undeformed waveguide and blank vibration isolators were measured at compression ratios of 0.95 and 0.90.

Prior to testing, the rubber elements were conditioned at 14 ± 1 °C for at least 16 hours, and the tests were conducted at the same temperature.

Each vibration isolator was compressed under a static load to the desired compression ratio χ . The applied force F_s , and height change of the rubber element from its unloaded situation X_s , were measured. The secant stiffness k_c was then calculated from equation (1).

Using the measured secant stiffness and magnitude of the dynamic stiffness from Table B1 gave the stiffness ratios a_1 and a_2 from equations (5) and (6). The results of these static tests are presented in Table C1.

Table C1: Static stiffnesses of vibration isolators

Vibration isolator	χ	k_c (N/m)	a_1	a_2
Waveguide	0.95	1.82×10^6	1.92	
Blank	0.95	2.41×10^5		1.89
Waveguide	0.90	2.15×10^6	1.63	
Blank	0.90	2.56×10^5		1.79

For a compression ratio of 0.95 the variation in the ratios a_1 and a_2 is 1.6 %, referenced to the value for the blank vibration isolator.

For a compression ratio 0.90 the variation in the ratios a_1 and a_2 is 8.9 %, referenced to the value for the blank vibration isolator.

Appendix D: Effectiveness of a Vibration Isolator

For a single degree-of-freedom system comprising a machine supported by a massless vibration isolator on a foundation, the effectiveness E of the vibration isolator is given by, Crede and Rozicka (1988),

$$E = \frac{H_1 + H_{VI} + H_2}{H_1 + H_2} \quad (D.1)$$

where H_1 is the mobility of the supported machine,
 H_{VI} is the mobility of the vibration isolator, and
 H_2 is the mobility of the foundation.

For the case of the waveguide and blank vibration isolator systems, the machine is represented by a mass, and the foundation is rigid. Let the vibration isolator be modelled by a spring of stiffness k and negligible damping, supporting the mass m . Let the motion be sinusoidal with frequency f . Therefore, the mobilities are given by

$$H_1 = \frac{1}{j2\pi f m} \quad (D.2)$$

$$H_{VI} = \frac{j2\pi f}{k} \quad (D.3)$$

and

$$H_2 = 0 \quad (D.4)$$

The natural frequency f_n of the system is given by

$$f_n = \frac{1}{2\pi} \sqrt{\frac{k}{m}} \quad (D.5)$$

Substituting equations (D.2) to (D.5) into equation (D.1) yields

$$E = 1 - \left(\frac{f}{f_n} \right)^2 \quad (D.6)$$

Therefore from equation (D.6), for frequencies well above the natural frequency of the system the effectiveness is approximately given by

$$E = \left(\frac{f}{f_n} \right)^2 \quad (\text{D.7})$$

Let E_{dB} be the effectiveness in dB. Then equation (D.7) gives

$$E_{dB} = 40 \log \left(\frac{f}{f_n} \right) \quad (\text{D.8})$$

Therefore from equation (D.8), the graph of the magnitude of the effectiveness against frequency asymptotes to a slope of 40 dB/decade. Also the effectiveness increases as the natural frequency decreases.

DISTRIBUTION LIST

Assessment of Waveguide Vibration Isolator

John D. Dickens

AUSTRALIA

DEFENCE ORGANISATION

Task Sponsor

S&T Program

Chief Defence Scientist
FAS Science Policy
AS Science Corporate Management
Director General Science Policy Development
Counsellor Defence Science, London (Doc Data Sheet)
Counsellor Defence Science, Washington (Doc Data Sheet)
Scientific Adviser to MRDC Thailand (Doc Data Sheet)
Scientific Adviser Policy and Command
Navy Scientific Adviser (Doc Data Sheet and distribution list only)

Scientific Adviser - Army (Doc Data Sheet and distribution list only)

Air Force Scientific Adviser
Director Trials

Aeronautical and Maritime Research Laboratory

Director
Chief of Maritime Platforms Division
Research Leader, Signature Management
Task Manager
John Dickens

DSTO Library and Archives

Library Fishermens Bend
Library Maribyrnong
Library Salisbury (2 copies)
Australian Archives
Library, MOD, Pyrmont (Doc Data sheet only)
*US Defense Technical Information Center, 2 copies
*UK Defence Research Information Centre, 2 copies
*Canada Defence Scientific Information Service, 1 copy
*NZ Defence Information Centre, 1 copy
National Library of Australia, 1 copy

Capability Development Division

Director General Maritime Development (Doc Data Sheet only)
Director General Land Development (Doc Data Sheet only)

Director General C3I Development (Doc Data Sheet only)
Director General Aerospace Development (Doc Data Sheet only)

Army

ABCA Office, G-1-34, Russell Offices, Canberra (4 copies)
SO (Science), DJFHQ(L), MILPO Enoggera, Queensland 4051 (Doc Data Sheet only)
NAPOC QWG Engineer NBCD c/- DENGRS-A, HQ Engineer Centre Liverpool Military Area, NSW 2174 (Doc Data Sheet only)

Intelligence Program

DGSTA Defence Intelligence Organisation

UNIVERSITIES AND COLLEGES

Australian Defence Force Academy
Library
Head of Aerospace and Mechanical Engineering
Deakin University, Serials Section (M list), Deakin University Library, Geelong, 3217
Senior Librarian, Hargrave Library, Monash University
Librarian, Flinders University

OTHER ORGANISATIONS

NASA (Canberra)
AGPS

OUTSIDE AUSTRALIA

ABSTRACTING AND INFORMATION ORGANISATIONS

Library, Chemical Abstracts Reference Service
Engineering Societies Library, US
Materials Information, Cambridge Scientific Abstracts, US
Documents Librarian, The Center for Research Libraries, US

INFORMATION EXCHANGE AGREEMENT PARTNERS

Acquisitions Unit, Science Reference and Information Service, UK
Library - Exchange Desk, National Institute of Standards and Technology, US

SPARES (5 copies)

Total number of copies: 46

DEFENCE SCIENCE AND TECHNOLOGY ORGANISATION DOCUMENT CONTROL DATA				1. PRIVACY MARKING/CAVEAT (OF DOCUMENT)			
				2. TITLE Assessment of Waveguide Vibration Isolator		3. SECURITY CLASSIFICATION (FOR UNCLASSIFIED REPORTS THAT ARE LIMITED RELEASE USE (L) NEXT TO DOCUMENT CLASSIFICATION) Document (U) Title (U) Abstract (U)	
4. AUTHOR(S) John D. Dickens			5. CORPORATE AUTHOR Aeronautical and Maritime Research Laboratory PO Box 4331 Melbourne Vic 3001 Australia				
6a. DSTO NUMBER DSTO-TR-0812		6b. AR NUMBER AR-010-905		6c. TYPE OF REPORT Technical Report		7. DOCUMENT DATE February 1999	
8. FILE NUMBER 510/207/0981	9. TASK NUMBER DST 94/266	10. TASK SPONSOR DSTO		11. NO. OF PAGES 52		12. NO. OF REFERENCES 15	
13. DOWNGRADING/DELIMITING INSTRUCTIONS			14. RELEASE AUTHORITY Chief, Maritime Platforms Division				
15. SECONDARY RELEASE STATEMENT OF THIS DOCUMENT <i>Approved for public release</i>							
OVERSEAS ENQUIRIES OUTSIDE STATED LIMITATIONS SHOULD BE REFERRED THROUGH DOCUMENT EXCHANGE, PO BOX 1500, SALISBURY, SA 5108							
16. DELIBERATE ANNOUNCEMENT No Limitations							
17. CASUAL ANNOUNCEMENT Yes							
18. DEFTTEST DESCRIPTORS -Vibration isolators, Compression ratio, Performance, Parameters							
19. ABSTRACT A method is proposed for comparing the dynamic performance of different types of vibration isolators, and relies on having equal compression ratios of the rubber elements. The method is used to compare a waveguide vibration isolator with a blank vibration isolator. The four-pole parameters of the vibration isolators are measured, and experimental data presented. There appears to be no significant advantage in using the waveguide vibration isolator.							