

Technical Report

May 1999



Pan American Climate Study (PACS)

Mooring Recovery Cruise Report
R/V *Melville* Cruise PACS03MV
6 September to 30 September 1998

by

William M. Ostrom
Bryan S. Way
Steven P. Anderson
Brent Jones
Erica Key
Gabriel Yuras

May 1999

DISTRIBUTION STATEMENT A
Approved for Public Release
Distribution Unlimited

19990716 063



Upper Ocean Processes Group
Woods Hole Oceanographic Institution
Woods Hole, Massachusetts 02543
UOP Technical Report 99-01

WHOI-99-06
UOP 99-01

Pan American Climate Study (PACS)

Mooring Recovery Cruise Report
R/V Melville Cruise PACS03MV
6 September to 30 September 1998

by

William M. Ostrom
Bryan S. Way
Steven P. Anderson
Brent Jones
Erica Key
Gabriel Yuras

Woods Hole Oceanographic Institution
Woods Hole, Massachusetts 02543

May 1999

Technical Report

Funding was provided by the National Oceanic and Atmospheric Administration
under contract number NA66GP0130.

Reproduction in whole or in part is permitted for any purpose of the United States
Government. This report should be cited as Woods Hole Oceanog. Inst. Tech. Rept.,
WHOI-99-06.

Approved for public release; distribution unlimited.

Approved for Distribution:

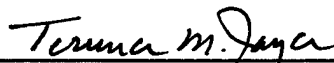

Terrence M. Joyce, Chair

Department of Physical Oceanography

Abstract

Two surface moorings were recovered during R/V *Melville* cruise PACS03MV in the eastern equatorial Pacific as part of the Pan American Climate Study (PACS). PACS is a NOAA-funded study with the goal of investigating links between sea-surface temperature variability in the tropical oceans near the Americas and climate over the American continents. The two moorings were deployed near 125°W, spanning the strong meridional sea-surface temperature gradient associated with the cold tongue south of the equator and the warmer ocean north of the equator, near the northernmost, summer location of the Inter-tropical Convergence Zone. The moored array was deployed to improve the understanding of air-sea fluxes and of the processes that control the evolution of the sea surface temperature field in the region.

Two surface moorings, located at 3°S, 125°W and 10°N, 125°W, belonging to the Upper Ocean Processes (UOP) Group at the Woods Hole Oceanographic Institution (WHOI), were recovered after being on station for eight months. This was the second setting of the two moorings that had been redeployed from the University of Washington's R/V *Thomas Thompson* cruise number 73.

The buoys of the two WHOI moorings were each equipped with meteorological instrumentation, including a Vector Averaging Wind Recorder (VAWR), and an Improved METeorological (IMET) system. The WHOI moorings also carried Vector Measuring Current Meters, single point temperature recorders, and conductivity and temperature recorders located in the upper 200 meters of the mooring line. In addition to the instrumentation noted above, a variety of other instruments, including an acoustic current meter, acoustic doppler current meters, bio-optical instrument packages and an acoustic rain gauge, were deployed during the PACS field program.

This report describes, in a general manner, the work that took place during R/V *Melville* cruise PACS03MV. A description of the WHOI moored array and instrumentation is provided. Details of the mooring designs and preliminary data from the CTD profiles are included.

Table of Contents

Abstract	1
List of Figures	3
List of Tables	4
Section 1: Introduction	5
Section 2: The Moored Array	7
A. WHOI Surface Moorings	7
1. Meteorological Instrumentation	12
a. Vector Averaging Wind Recorder	15
b. Improved METeorological System	15
c. Stand-alone Precipitation Instrument	18
d. ASIMET Relative Humidity/Air Temperature Instrument	18
2. Sub-Surface Instrumentation	18
a. Mooring Tension Recorder and Buoy Acceleration	18
b. Sub-surface Argos Transmitter	20
c. SEACAT Conductivity and Temperature Recorders	20
d. MicroCAT Conductivity and Temperature Recorder	20
e. Brancker Temperature Recorders	21
f. Miniature Temperature Recorder	21
g. WHOI Vector Measuring Current Meters	21
h. WaDaR Temperature Recorder	22
i. Sherman Current Meter	22
j. Bio-optical Package	22
k. Acoustic Release	23
B. Other Instrumentation	23
1. WHOI Shipboard Meteorological System	23
2. Chlorophyll Absorption Meter (CHLAM)	25
3. M-AERI	25
4. Radiosondes	25
5. Hard Hats	28
6. ALL-SKY Mirror	28
7. SOLO Drifters	28
Section 3: Cruise Chronology	31
Acknowledgments	35
References	35
Appendix 1: Cruise Participants	36
Appendix 2: CTD stations occupied during PACS03MV	37
Appendix 3: Instrument Time Marks	52
Appendix 4: WHOI Instrumentation Deployed during PACS 1 and 2	54
Appendix 5: Wind Direction Sensor Comparison Tests	58
Appendix 6: VMCM Record Format	63
Appendix 7: Mooring Recovery Operations	64
Appendix 8: PACS Antifouling Coating Test Results	69

Table of Figures

FIGURE 1: PACS MOORING CRUISE SCHEDULE.....	5
FIGURE 2: CRUISE TRACK AND MOORING LOCATIONS.....	6
FIGURE 3: WHOI PACS 2 NORTH MOORING SCHEMATIC.....	8
FIGURE 4: WHOI PACS 2 SOUTH MOORING SCHEMATIC.....	9
FIGURE 5: NORTH DISCUS BUOY WITH TOWER AND BRIDLE INSTRUMENTATION.....	10
FIGURE 6: SOUTH DISCUS BUOY WITH TOWER AND BRIDLE INSTRUMENTATION.....	11
FIGURE 7: PACS 2 METEOROLOGICAL INSTRUMENT PLACEMENT ON BUOY TOWER TOPS.....	12
FIGURE 8: BOW MOUNT FOR INFRARED SEA SURFACE TEMPERATURE SENSOR.....	24
FIGURE 9: RADIOSONDE SOUNDING PLOT.....	27
FIGURE 10: SCHEMATIC OF A SOLO DRIFTER.....	30
FIGURE A2-1: CHART SHOWING CTD STATION LOCATIONS.....	38
FIGURE A2-2: COMPOSITE PLOT OF CTD DATA TAKEN DURING PACS03MV.....	39
FIGURE A2-3: PROFILES FROM CTD STATIONS 1 AND 2.....	40
FIGURE A2-4: PROFILES FROM CTD STATIONS 3 AND 4.....	41
FIGURE A2-5: PROFILES FROM CTD STATIONS 5 AND 6.....	42
FIGURE A2-6: PROFILES FROM CTD STATIONS 7 AND 8.....	43
FIGURE A2-7: PROFILES FROM CTD STATIONS 9 AND 10.....	44
FIGURE A2-8: PROFILES FROM CTD STATIONS 11 AND 12.....	45
FIGURE A2-9: PROFILES FROM CTD STATIONS 13 AND 14.....	46
FIGURE A2-10: PROFILES FROM CTD STATIONS 15 AND 16.....	47
FIGURE A2-11: PROFILES FROM CTD STATIONS 17 AND 18.....	48
FIGURE A2-12: PROFILES FROM CTD STATIONS 19 AND 20.....	49
FIGURE A2-13: PROFILES FROM CTD STATIONS 21 AND 22.....	50
FIGURE A2-14: PROFILES FROM CTD STATIONS 23.....	51
FIGURE A5-1: WIND DIRECTION COMPARISON TESTS, PACS 2 NORTH.....	59
FIGURE A5-2: WIND DIRECTION COMPARISON TESTS, PACS 2 SOUTH.....	60
FIGURE A5- 3: WIND COMPARISON TESTS (HAWAII), PACS 2 NORTH.....	61
FIGURE A5- 4: WIND COMPARISON TESTS (HAWAII), PACS 2 SOUTH.....	62
FIGURE A7-1: DECK LAYOUT TO PACS 2 NORTH AND SOUTH RECOVERY.....	65
FIGURE A7-2: DISCUS BAIL CONFIGURATION.....	67
FIGURE A8-1: ANTIFOULING PAINT TEST LOCATIONS, PACS 2 NORTH BUOY HULL.....	70
FIGURE A8-2: ANTIFOULING PAINT TEST LOCATIONS, PACS 2 SOUTH BUOY HULL.....	71

List of Tables

TABLE 1: PACS 2 MOORING DEPLOYMENT/RECOVERY INFORMATION	6
TABLE 2: NORTH DISCUS BUOY-MOUNTED SENSORS AND CORRESPONDING ELEVATIONS.	13
TABLE 3: SOUTH DISCUS BUOY-MOUNTED SENSORS AND CORRESPONDING ELEVATIONS.	14
TABLE 4: VAWR SENSOR SPECIFICATIONS.....	16
TABLE 5: IMET SENSOR SPECIFICATIONS.....	17
TABLE 6: PACS 2 SUB-SURFACE INSTRUMENTATION	19
TABLE 7: RADIOSONDE LOG	26
TABLE 8: HARD HAT SST LOG.....	29
TABLE 9: SOLO DRIFTERS DEPLOYMENT TIMES AND POSITIONS.	30
TABLE A2-1: CTD STATIONS TAKEN DURING PACS03MV	37
TABLE A8-1: ANTIFOULING COATINGS TESTED, PACS 2.....	69
TABLE A8-2: ANTIFOULING COATING PERFORMANCE, PACS 1, NORTH AND SOUTH	74
TABLE A8-3: ANTIFOULING COATING PERFORMANCE, PACS 2, NORTH AND SOUTH	74

Section 1: Introduction

The R/V *Melville* (PACS03MV) departed San Diego on 8 September 1998, at 1700 hours UTC. The purpose of the cruise was to recover two Woods Hole Oceanographic Institution (WHOI) surface moorings. The moorings were part of the Pan American Climate (PACS) Study funded by the National Oceanic and Atmospheric Administration (NOAA). This was the third of three cruises planned for the experiment. The PACS cruise schedule is shown in Figure 1.

The cruise involved personnel from the Upper Ocean Processes (UOP) Group at WHOI and the Universities of Miami, California San Diego, California Santa Barbara and Concepción, Chile. Appendix 1 lists the cruise participants. Figure 2 shows the cruise track and the mooring locations. Table 1 lists the deployment and recovery dates for the second setting of the moored array as well as the surveyed anchor positions. The second deployment of the PACS moorings is referred to as PACS 2.

Eight Sounding Oceanographic Lagrangian Observer (SOLO) instruments belonging to Scripps Institution of Oceanography (SIO) were deployed during the cruise. A total of 31 conductivity-temperature-depth (CTD) casts were made throughout the cruise. Appendix 2 contains a listing of the CTD positions, start times and maximum depth of the stations, as well as a plot of the CTD station locations.

This report has a total of three sections including this brief introduction. The second section describes the PACS moored array with emphasis on the WHOI moorings and their instrumentation. The third section presents a chronology of the cruise.

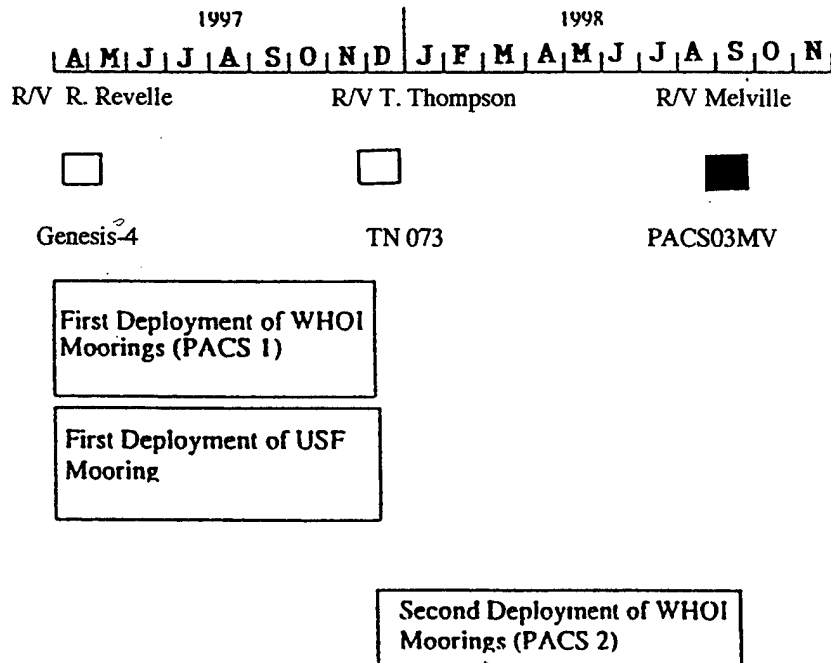

Figure 1: PACS mooring cruise schedule.

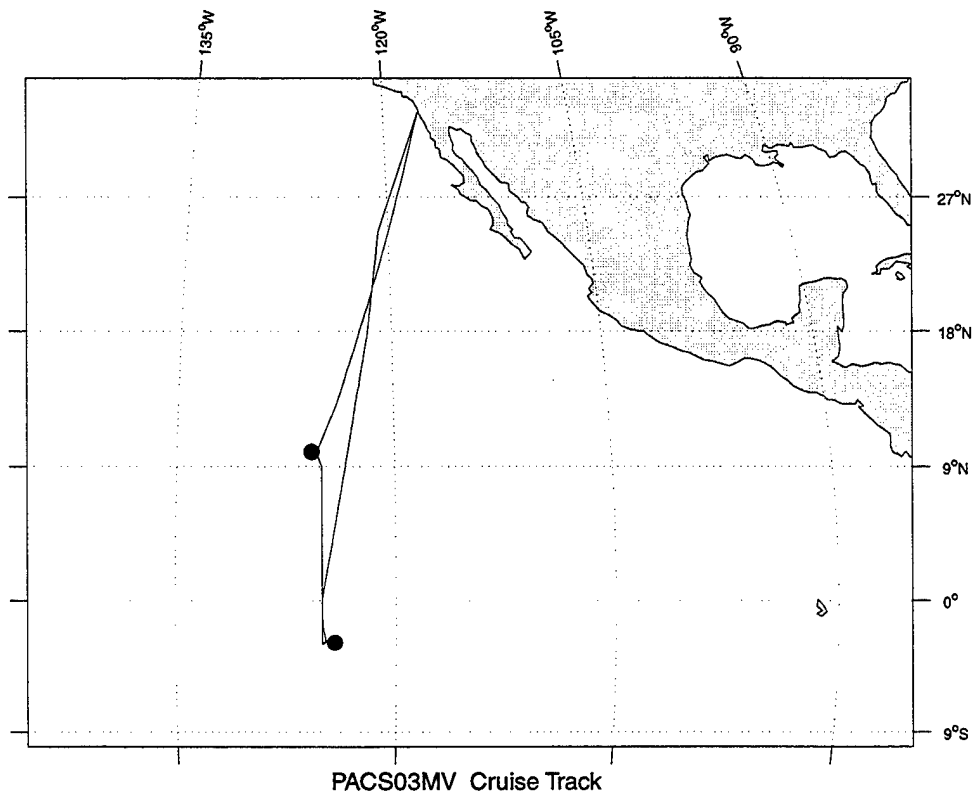

Figure 2: Cruise track and mooring locations.

Table 1: PACS 2 Mooring deployment/recovery information

Mooring	Deployment Date and Time	Recovery Date	Anchor Position
WHOI PACS South Discus Buoy WHOI Mooring Reference No. 1020	9 December 1997 @ 0036 UTC	20 September 1998 @ 1429 UTC	2° 46.231' S 124° 39.733' W
WHOI PACS North Discus Buoy WHOI Mooring Reference No. 1021	19 December 1997 @ 0119 UTC	14 September 1998 @ 1429 UTC	9° 55.787' N 125° 24.772' W

Section 2: The Moored Array

Two surface moorings were deployed from the R/V *Thomas Thompson* (cruise number 073) in November 1997 as the second 8-month deployment of PACS. The two moorings were prepared and deployed by the UOP Group at WHOI. The WHOI moorings were nominally located in the eastern Pacific at latitudes 10°N and 3°S along longitude 125°W. In this report the WHOI moorings are referred to as either North or South. The moorings carried both meteorological and oceanographic instrumentation.

A. WHOI Surface Moorings

The PACS 2 North and South mooring drawings are shown in Figures 3 and 4 respectively. The WHOI moorings are an inverse catenary design utilizing wire rope, chain, nylon and polypropylene line. Each mooring has a scope of 1.22 (Scope = mooring slack length/water depth). The surface buoy is a three-meter diameter discus buoy with a two-part aluminum tower and rigid bridle. Figures 5 and 6 schematically show the PACS 2 North and South discus buoys respectively.

The design of the WHOI surface moorings took into consideration the predicted currents, winds, and sea state conditions expected during the deployment duration. Further they were constructed using hardware and designs already proven in the recent Arabian Sea deployment.

Shackles used on the WHOI moorings were shot peened to improve their fatigue endurance. Weldless endlinks were used based on their superior performance during fatigue testing. Vector measuring current meter (VMCM) cages were gusseted and welds redone to meet new specifications established during Arabian Sea cyclic fatigue testing. More information about the design effort and cyclic fatigue tests can be found in Trask *et al.*, 1995; and Trask and Weller, 1995.

Each of the PACS 2 North and South moorings had two suites of meteorological instruments, 10 VMCMs, 17 temperature recorders with one mounted in a surface following float, and a mooring tension and buoy acceleration recorder. The PACS 2 moorings were outfitted with more conductivity/temperature instruments than the PACS 1 moorings. Each PACS 2 mooring had eight conductivity/temperature sensors. The PACS 2 South mooring had a bio-optical instrument at 27.5 meters which, along with other variables, made measurements of conductivity and temperature. The conductivity measurement made by the bio-optical instrument is one of eight made on the South mooring. A Sherman acoustic doppler current meter was also deployed at 120 meters on the PACS 2 South mooring.

Each instrument used on the WHOI moorings was given a pre-cruise electronics check-out prior to being loaded onto the ship. Pre-cruise preparation information for the second deployment were conducted at the University of Hawaii Marine Center located on Snug Harbor, Honolulu, Hawaii can be found in Trask *et al.*, 1998.

All of the instrumentation used on the WHOI moorings had some type of pre-deployment time mark applied. The meteorological systems had their short-wave radiation sensors black bagged for two record cycles. The VMCMs had their rotors spun. All of the temperature recorders were put in an ice bath for at least two record intervals. The times associated with these temperature spikes are recorded in each instrument's respective log book and appear in Appendix 3. The time marks can be used to verify the accuracy of the

Figure 3: WHOI PACS 2 North mooring schematic.

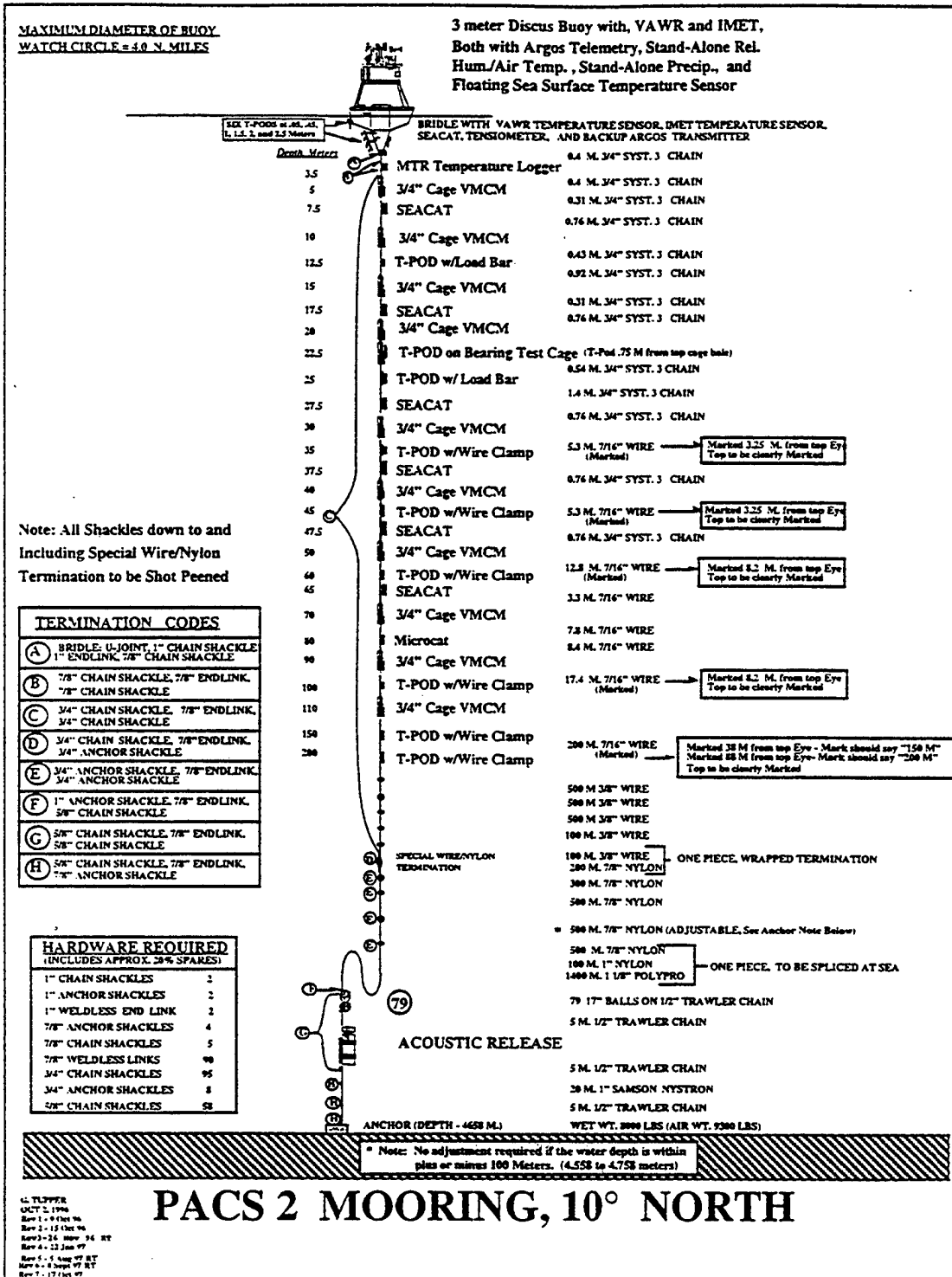

Figure 4: WHOI PACS 2 South mooring schematic.

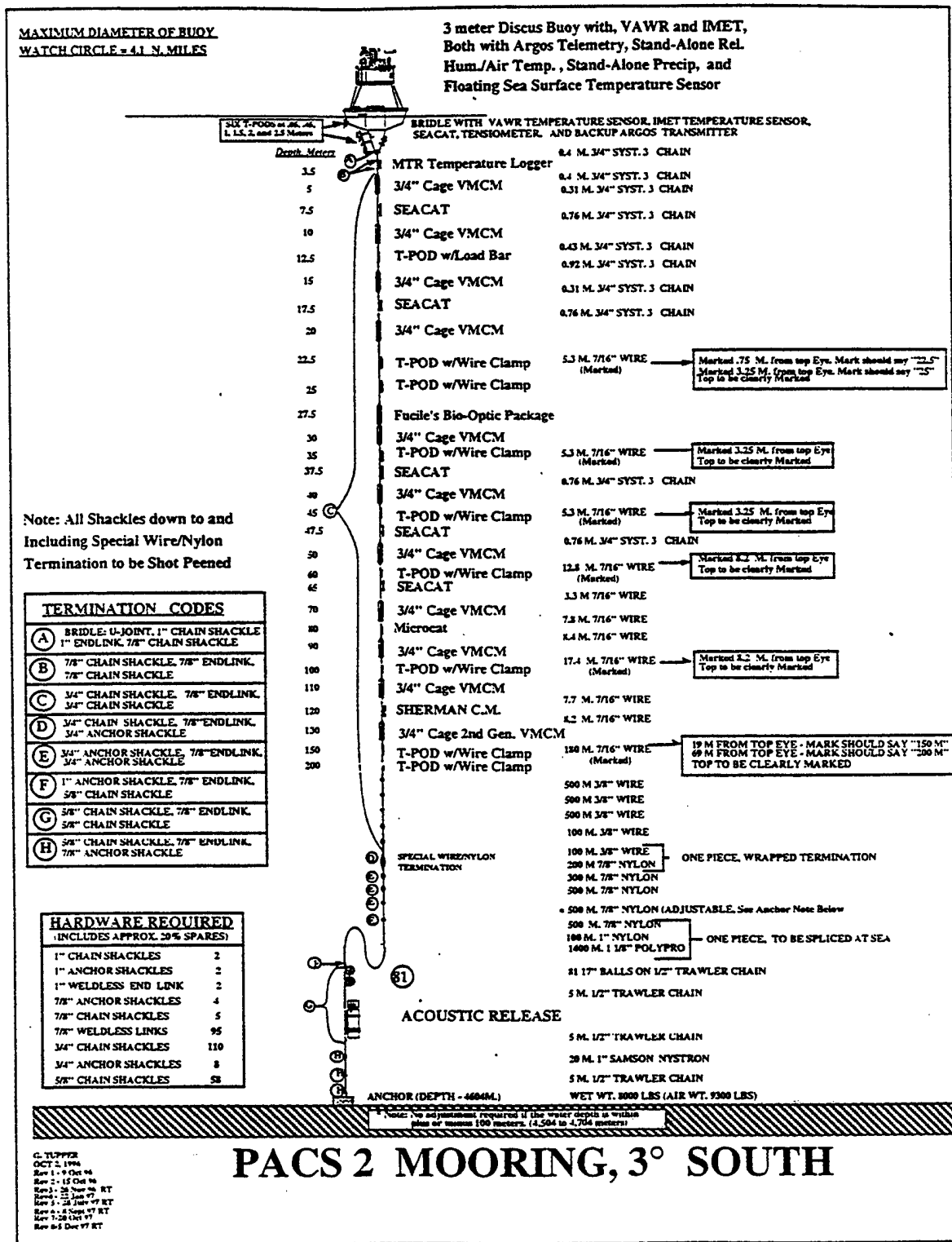

Figure 5: North discus buoy with tower and bridle instrumentation.

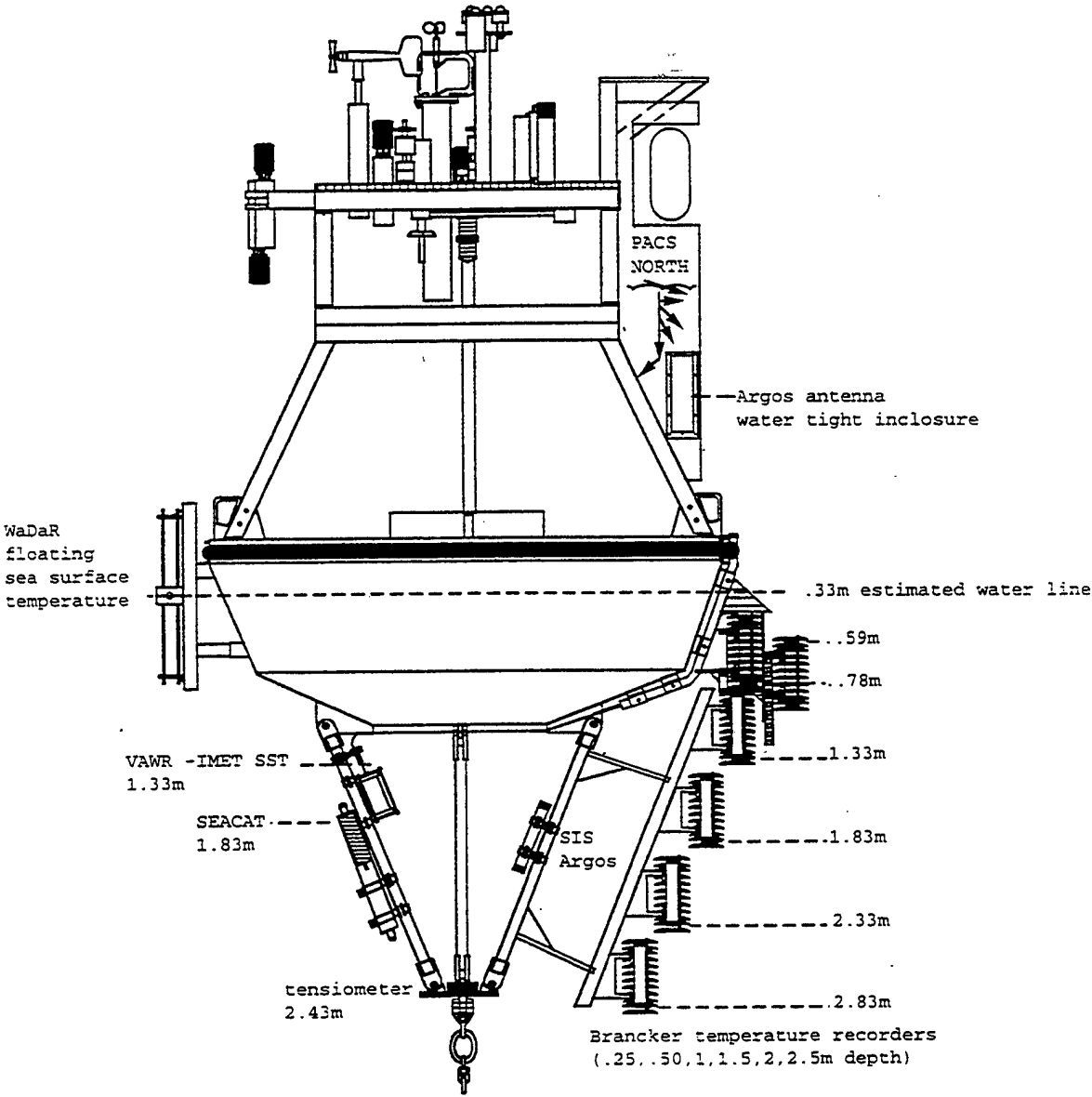
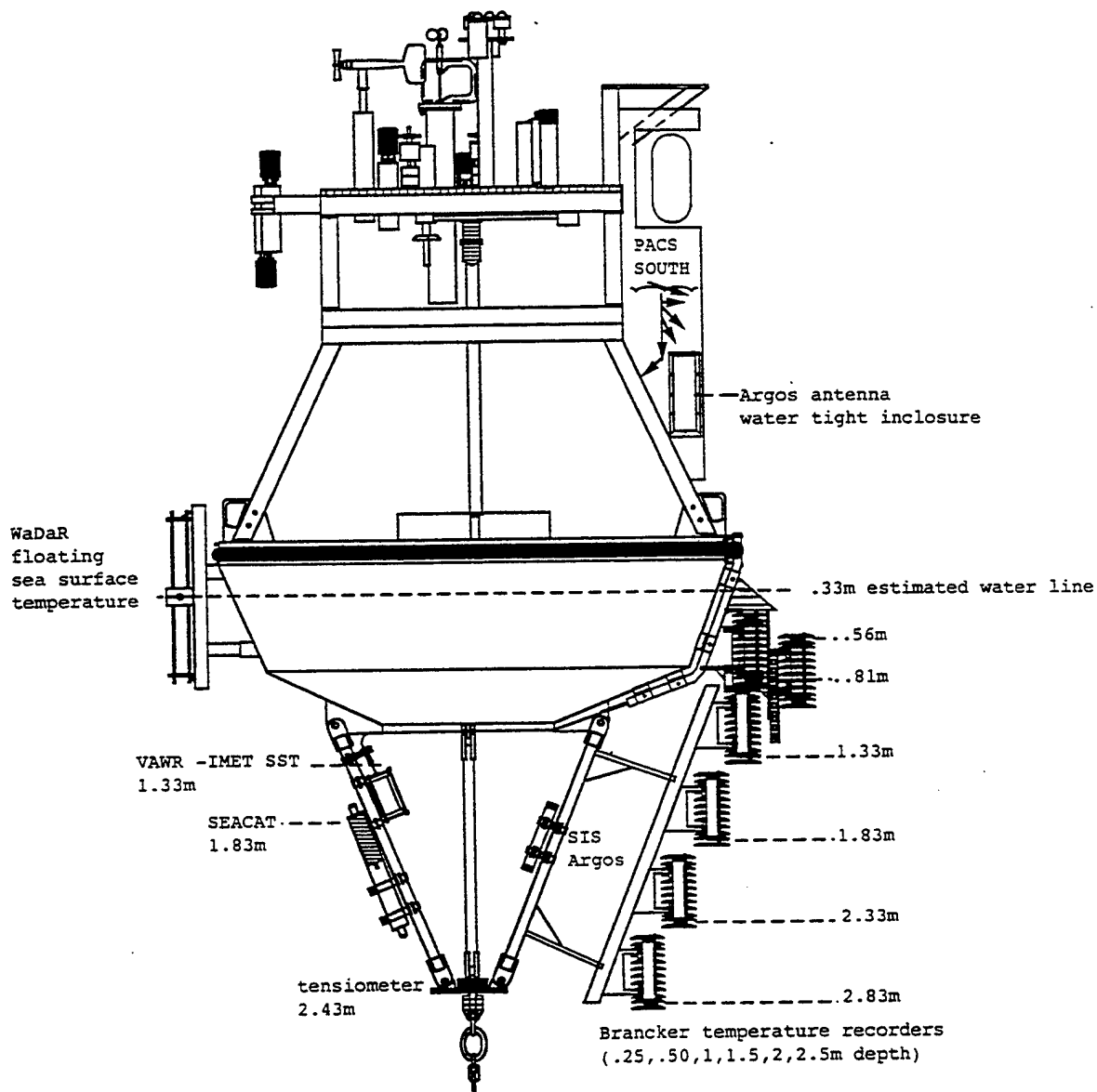

Figure 6: South discus buoy with tower and bridle instrumentation.



instrument's clock in data processing. Appendix 4 has a complete listing of all WHOI instrumentation deployed during PACS 2. For each instrument type the listing shows the instrument serial number, the mooring on which it was deployed and the corresponding depth.

Details about each type of instrument are provided below beginning with the meteorological instrumentation and then followed by the sub-surface instrumentation. Specific information about the instrumentation deployed during PACS 1 can be found in Way *et al.*, 1998.

1. Meteorological Instrumentation

The WHOI discus buoys were outfitted with two separate meteorological packages. One system was a Vector Averaging Wind Recorder (VAWR) which logged and telemetered data from eight meteorological sensors. The second meteorological data recording system called IMET (Improved METeorological measurements) logged data from nine meteorological sensors, and the data were also telemetered. In addition to the VAWR and IMET systems deployed on the PACS 2 buoys, there was also a stand-alone, internally recording instrument that measured precipitation as well as another that measured both relative humidity and air temperature. The relative humidity instrument is an improved version of the IMET relative humidity module in that it was self-powered and recorded its data internally. It was part of a family of instruments called VOS IMET which have been in use on Volunteer Operating Ships (VOS). Figure 7 shows the placement of the sensors on the buoy tower top.

Tables 2 and 3 list the buoy-mounted instrumentation on the PACS 2 North and South buoys. The information listed includes sensor identification and sensor height with respect to the water line. The height of all buoy-mounted instrumentation is initially referenced to the buoy deck since the actual water line is never known until after deployment. At the time of recovery, if not sooner, the location of the water line is measured with respect to the buoy deck. On the PACS 2 buoys the water line was measured to be .33 meters below the deck of the buoy.

A wind direction sensor comparison test was conducted for both the PACS 2 South and North buoys in Woods Hole and at the University of Hawaii Marine Center. This was done to confirm that the compasses of each VAWR and IMET were in proper working order. The data from the direction comparison tests can be found in Appendix 5. The meteorological instruments are described in detail below.

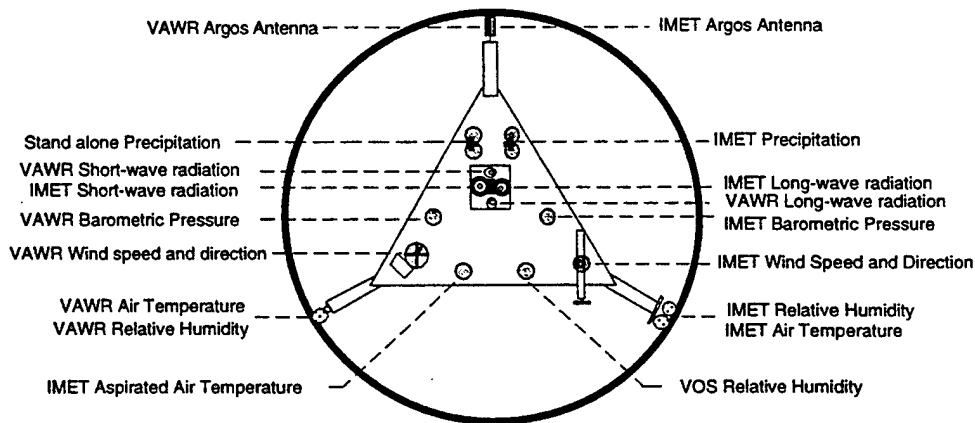

Figure 7: PACS 2 meteorological instrument placement on buoy tower tops.

Table 2: North discus buoy-mounted sensors and corresponding elevations.

Parameter	Sensor ID	Elevation relative to buoy deck [meters]	Measurement location
IMET	Logger 291		
Wind speed	WND 113	2.95	Prop Axis
Wind direction	WND 113	2.95	Prop Axis
Air temperature	TMP 110	1.74	Mid shield
Aspirated air temp	TMP 102	1.85	Tip of Probe
Relative humidity	HRH 111	2.2	Mid shield
Barometric pressure	BPR 105	2.39	Center of port
Precipitation	PRC 108	2.74	Top of funnel
Long-wave radiation	LWR 101 (28908)	3.06	Base of dome
Short-wave radiation	SWR 002	3.06	Base of dome
Sea temperature	SST 106	-1.33	End of Probe
VAWR	V721WR		
Wind speed	V721WR	2.97	Center of Cups
Wind direction	V721WR	2.71	Mid vane
Air temperature	5824	1.79	Mid Shield
Relative humidity	V-022-01	2.14	Mid Shield
Barometric pressure	55796	2.39	Center of port
Long-wave radiation	21787	3.06	Base of dome
Short-wave radiation	24103	3.06	Base of dome
Sea temperature	5523	-1.33	End of probe
Stand-alone precipitation	004	2.73	Top of funnel
ASIMET relative humidity	HRH 204	2.47	Mid Shield
Floating sea surface temperature	WaDaR 272	0.0	
SEACAT conductivity/temp	2322	-1.83	At temperature probe
Temperature recorder	3837	-0.59	Thermistor end
Temperature recorder	3833	-0.78	Thermistor end
Temperature recorder	3308	-1.33	Thermistor end
Temperature recorder	3291	-1.83	Thermistor end
Temperature recorder	3296	-2.33	Thermistor end
Temperature recorder	4402	-2.83	Thermistor end
Tension cell	94034		Base of bridle
Nominal distace between buoy deck and water line is .33 meters			

Table 3: South discus buoy-mounted sensors and corresponding elevations.

Parameter	Sensor ID	Elevation from buoy deck (m)	Measurement Location
IMET			
Wind speed	WND 108	2.96	Prop Axis
Wind direction	WND 108	2.96	Prop Axis
Air temperature	TMP 108	1.76	Mid shield
Aspirated air temp	TMP005	1.76	Tip of Probe
Relative humidity	HRH 108 (26356)	2.19	Mid shield
Barometric pressure	BPR 006	2.38	Center of port
Precipitation	PRC 004	2.74	Top of funnel
Long-wave radiation	LWR 103	3.06	Base of dome
Short-wave radiation	SWR 102	3.06	Base of dome
Sea temperature	SST 003	-1.33	End of Probe
VAWR			
Wind speed	V706WR	2.97	Center of Cups
Wind direction	V706WR	2.71	Mid vane
Air temperature	5817	1.79	Mid Shield
Relative humidity	V-036-01	2.15	Mid Shield
Barometric pressure	45918	2.38	Center of port
Long-wave radiation	28872	3.06	Base of dome
Short-wave radiation	28416	3.06	Base of dome
Sea temperature	5539	-1.33	End of probe
Stand-alone precipitation	003	2.72	Top of funnel
ASIMET rel. hum.	HRH 206	2.49	Mid Shield
Floating SST	WaDaR 273	0.00	
SEACAT conductivity /temperature	1882	-1.83	At temperature probe
Temperature recorder	4228	-0.56	Thermistor end
Temperature recorder	3274	-0.81	Thermistor end
Temperature recorder	3271	-1.33	Thermistor end
Temperature recorder	4486	-1.83	Thermistor end
Temperature recorder	3830	-2.33	Thermistor end
Temperature recorder	3834	-2.83	Thermistor end
Tension cell	43390		

a. Vector Averaging Wind Recorder

One of the two meteorological units mounted on the WHOI three-meter diameter discus buoy was a Vector Averaging Wind Recorder (VAWR), which is configured to measure wind speed, wind direction, short-wave radiation, long-wave radiation, relative humidity, barometric pressure, air temperature, and sea surface temperature. Recording on a digital cassette, the VAWR wrote data to tape every 15.0 minutes. Table 4 shows the type of sensors used for the meteorological measurements and the sampling scheme. Data from the VAWR were telemetered via satellite back to WHOI through Service Argos. The VAWR Argos transmitter has three PTT ID numbers for data transmission, one of which is used for obtaining position information. The standard temperature range typically used in the VAWR is 0 to 30°C. This range for the PACS deployments was modified to be 0° to 35°C due to the expected high temperatures. The VAWR sea surface temperature (SST) sensor was mounted on the bridle at a depth of approximately one meter. A continuous length of cable was run from the VAWR to the buoy deck and then down to the bridle mounted SST sensor via an external aluminum pipe mounted on the side of the buoy to protect the cable. This method eliminated the need for multiple bulkhead connectors which can affect the temperature reading. Details of the VAWR configuration can be found in Trask *et al.*, 1995.

b. Improved METeorological System

The Improved METeorological (IMET) system for the PACS WHOI discus buoys consisted of nine IMET sensor modules and one Argos transmitter module to telemeter data via satellite back to WHOI through Service Argos. Table 5 details IMET sensor specifications. The following IMET modules types were deployed on the PACS discus buoys:

1. relative humidity with temperature
2. barometric pressure
3. air temperature (R. M. Young passive shield)
4. air temperature (aspirated shield)
5. sea surface temperature
6. precipitation
7. wind speed and direction
8. short-wave radiation
9. long-wave radiation

All IMET modules for the PACS experiment were modified for lower power consumption so that a non-rechargeable alkaline battery pack could be used in the buoy well.

The data logger for the system is based on an Onset Computer, Corp., model 7 Tattletale computer with hard drive which is also configured and programmed with power conservation in mind. An associated interface board ties the model 7 via individual power and RS-485 communications lines to each of the nine IMET modules including the PTT module.

Table 4: VAWR sensor specifications

Parameter	Sensor Type	Nominal Accuracy	Comments
Wind speed	R. M. Young 3-cup 3-cup Anemometer	+5% +/-2%	Vector - averaged Note 1
Wind direction	Integral vane w/vane follower WHOI/EG&G	+/- 1 bit 5.6°	Vector- averaged
Insolation	Pyranometer Eppley 8-48	+/-3%	Averaged of reading
Long-wave Radiation	Pyrgeometer Eppley PIR	+/- 10%	Averaged Note 2
Thermopile	PIR		Note 3
Body temp.	10K @ 25° C		
Dome temp.	10K @ 25° C		
Relative humidity	Variable Dielectric Conductor Vaisala Humicap 0062HM	+/- 2% RH	3.515 sec. Sample Note 4
Barometric pressure	Quartz crystal Digiquartz Paroscientific Model 215, 216	+/- 0.2 mbars wind < 20 m/s	2.636 sec. Sample Note 4
Sea temperature	Thermistor Thermometrics 4K @ 25°C	+/- .005°C	Note 5
Air temperature	Thermistor Yellow Springs #44034 5K @ 25°C	+/- 0.2°C wind > 5 m/s	Note 6

Notes:

1. Over estimation of wind speed is characteristic of cup anemometers
2. LWR body temperature is measured during the third quarter of the recording interval for one quarter of the record time. Error associated with solar heating is not included in accuracy.
3. LWR dome temperature is measured during the fourth quarter of the recording interval, for one quarter of the record time
4. Relative humidity and barometric pressure are burst samples taken in the middle of the recording interval.
5. Sea temperature is measured during the first quarter of the recording interval, for one quarter of the record time.
6. Air temperature is measured during the second quarter of the recording interval, for one quarter of the record time. Error associated with solar heating is not included in accuracy.

Table 5: IMET sensor specifications

<u>Parameter</u>	<u>Sensor</u>	<u>Nominal Accuracy</u>
Air temperature (Static Shield)	Platinum Resistance Thermometer	+/- .25°C
Aspirated Air Temperature	Platinum Resistance Thermometer	+/- .10°C
Sea temperature	Platinum Resistance Thermometer	+/- .005°C
Relative humidity	Rotronic MP-100F	+/- 3%
Barometric pressure	Quartz crystal AIR DB-1A	+/- .5 mbar
Wind speed and Wind direction	R. M. Young model 5103 Wind Monitor	-3% (speed) +/- 1.5° (dir)
Short-wave radiation	Temperature Compensated Thermopile Eppley PSP	+/- 3%
Long-wave radiation	Pyrometer Eppley PIR	+/- 10%
Precipitation	R. M. Young model 50201 Self-siphoning rain gauge	+/- 10%

Notes:

The logger polls all IMET modules at one-minute intervals (takes several seconds) and then goes to low power sleep mode for the rest of the minute. Data is written to disk once per hour. The logger also monitors main battery and aspirated temperature battery voltage.

The air temperature, sea-surface temperature, barometric pressure, relative humidity, long-wave radiation and precipitation modules take a sample once per minute and then go to low power sleep mode for the rest of the minute.

The short-wave radiation module takes a sample every ten seconds and produces a running one minute average of the six most recent samples. It goes to low power sleep mode between ten second samples.

The vane on the wind module is sampled at one-second intervals and averaged over 15 seconds. The compass is sampled every 15 seconds and the wind speed is averaged every 15 seconds. East and north current components are computed every 15 seconds.

Once a minute the logger stores an average east and north component that is an average of the most recent four 15 second averages. In addition average speed from four 15 second averages is stored, along with the maximum and minimum speed during the previous minute, average vane computed from four 15-second averages, and the most recent compass reading.

In addition, an IMET Argos PTT module was set for three IDs and transmits via satellite the most recent six hours of one-hour averages from the IMET modules. At the start of each hour, the previous hour's data is averaged and sent to the PTT, bumping the oldest hour's data out of the data buffer.

c. Stand-alone Precipitation Instrument

A self-contained precipitation instrument was mounted on the tower of the PACS 2 discus buoys. This instrument, developed and built by members of the UOP Group, takes a single-point measurement of rainfall at a desired record interval. The sensor used is an R. M. Young, model 050202, self-siphoning rain gauge. This sensor uses a capacitive measurement technique to measure the volume of rain water deposited inside a collection chamber. It automatically empties in about 20 seconds when the chamber is full. The output of the sensor is 0 to 5 Vdc, which represents 0 to 50 mm of rainfall in the gauge. The sensor was sampled every 3.75 minutes during the PACS 2 deployment. The logger is an Onset Computer, Corp., model 4A Tattletale, with expanded memory to 512K. The unit is powered by its own internal battery pack.

d. ASIMET Relative Humidity/Air Temperature Instrument

An ASIMET relative humidity module was mounted on both the North and South discus buoys deployed during PACS 2. The ASIMET module is an improved version of the IMET module developed for the World Ocean Circulation Experiment (WOCE) program. ASIMET modules are self-powered and internally recording. The relative humidity measurement is made with a Rotronic MP-101A sensor. The sensor is packaged in a custom housing, which is more rugged than the standard housing and with high pressure water seals. The humidity temperature probe provides analog outputs of 0 volts to 1.0 volts DC for humidity (1 to 100% rh); and 0 to 1.0 volts DC for temperature (-40° to +60°C). These signals are amplified and converted to digital in the module. One set of measurements are made every minute and calibrated via a fourth order polynomial for rh% and degrees C. The probe is placed inside a standard R. M. Young multi-plate radiation shield.

2. Sub-Surface Instrumentation

Since the water line is not exactly known until after deployment, the depth of the sub-surface instrumentation, that is mounted directly to the discus buoy bridle, is initially referenced to the buoy deck. At the time of recovery, if not sooner, the location of the water line is measured with respect to the buoy deck. In the case of the PACS 2 buoys the water line was measured to be .33 meters below the deck of the buoy. Refer to Tables 2, 3, 4, and 5, as well as Figures 3, 4, 5, and 6 for information regarding the depth of buoy-mounted, sub-surface instrumentation. Table 6 lists the PACS 2 sub-surface instrumentation and the depths where they were deployed.

The remainder of this section will describe the sub-surface instrumentation deployed during PACS .

a. Mooring Tension Recorder and Buoy Acceleration

Mooring tension was measured at the base of the rigid bridle on both the PACS 2 South and North buoys. The tension cell on the North buoy was an Omegadyne, Inc., model TH-LB1B(SPL), with a load range of 0 pounds to 10,000 pounds. The tension cell on the South buoy was a D. J. Instruments, model A-16012, also with a load range of 0 pounds to 10,000 pounds. Inside the well of each buoy was a three-axis accelerometer manufactured by Summit Instruments, model #34103A, which measures X, Y, and Z components. The tension and acceleration data were recorded using an Onset Computer, Corp.,

Table 6: PACS 2 Sub-Surface Instrumentation

Depth	WHOI South	WHOI North
Surface	WaDaR-273	WaDaR 272
.25	T-4228	T-3837
.50	T-3274	T-3833
1.0	T-3271	T-3308
1.0	VAWR SST	VAWR SST
1.0	IMET SST 003	IMET SST 106
1.5	T-4486	T-3291
1.5	SEACAT 1882	SEACAT 2322
2.0	T-3830	T-3296
2.5	T-3834	T-4402
3.5	MTR-3242	MTR-3241
5.0	VM-045	VM-017
7.5	SEACAT 1874	SEACAT 1881
10.0	VM-023	VM-044
12.5	T-3763	T-4488
15.0	VM-041	VM-055
17.5	SEACAT 1878	SEACAT 141
20.0	VM-043	VM-010
22.5	T-3506	T-3508
25.0	T-3507	T-4493
27.5	Bio-Optical Pkg	SEACAT 1875
30.0	VM-022	VM-028
35.0	T-3301	T-2535
37.5	SEACAT 1876	SEACAT 1873
40.0	VM-051	VM-027
45.0	T-3831	T-2541
47.5	SEACAT 141	SEACAT 927
50.0	VM-053	VM-002
60.0	T-3702	T-2537
65.0	SEACAT 1880	SEACAT 1877
70.0	VM-034	VM-012
80.0	MicroCAT 008	MicroCAT 011
90.0	VM-030	VM-052
100.0	T-3299	T-3701
110.0	VM-040	VM-001
120.0	Sherman CM 001	-----
130.0	VM-201	-----
150.0	T-2533	T-3764
200.0	T-2536	T-3835

Legend

T-####	Brancker Temperature Recorder
SEACAT ####	SEACAT Conductivity and Temperature Recorder
MTR-###	Miniature Temperature Recorder
WaDaR-###	WaDaR Temperature Recorder
MicroCAT-###	MicroCAT Conductivity and Temperature Recorder
VM-###	Vector Measuring Current Meter
Sherman CM ##	SIO acoustic doppler current meter
Bio-Optical Pkg	WHOI bio-optical package

model 6 Tattletale, with a 40 Mega Byte hard drive attached. Tension and acceleration were sampled every 12 hours beginning at 0000 UTC and 1200 UTC at a 4 HZ rate for a period of 23 minutes. The data from a two-day period were stored in a temporary buffer where it was then written to the disk drive. A time spike was applied to the tension cells prior to deployment and after recovery by pulling on the bridle bail with an aircraft strap.

b. Sub-surface Argos Transmitter

An NACLS, Inc., Sub-surface Mooring Monitor (SMM) was mounted upside down on the bridle of each disc buoy as a backup recovery aid in the event that the mooring parts close to the buoy and the buoy become unstable and flip upside down.

c. SEACAT Conductivity and Temperature Recorders

A total of 13 Sea-Bird, Inc., SEACAT conductivity and temperature recorders were deployed on the PACS 2 surface moorings. The model SBE 16 SEACAT is designed to measure and record temperature and conductivity at high levels of accuracy while deployed in a moored application. Powered by internal batteries, a SEACAT is capable of recording data for periods of a year or more. Data is acquired at intervals set by the user. This interval can be changed at up to nine, predetermined dates. An internal back-up battery supports memory and the real time clock in the event of failure or exhaustion of the main battery supply. Communication with the SEACAT is over a three-wire RS-232 link. The SEACAT is capable of storing a total of 64,754 samples. A sample rate of 450 seconds was used on the PACS 2 SEACATs. The shallowest SEACAT was mounted directly to the bridle of each of the WHOI disc buoys. The others were mounted on in-line tension bars and deployed at various depths throughout the moorings. Shaft anodes were secured to the in-line tension bars to reduce the potential for electrolysis.

d. MicroCAT Conductivity and Temperature Recorder

The Sea-Bird MicroCAT, model SBE37, is a high-accuracy, conductivity and temperature recorder with internal battery and memory, designed for long term mooring deployments. It includes a standard serial interface to communicate with a PC. Its recorded data are stored in non-volatile FLASH memory. The temperature range of the instrument is -5° to $+35^{\circ}\text{C}$ and the conductivity range is 0 to 6 Siemens/meter. The pressure housing is made of titanium and is rated for 7,000 meters. The conductivity cell is protected from bio-fouling by the placement of antifoulant cylinders at each end of the conductivity cell tube. The MicroCAT is capable of storing 120,000 samples of temperature, conductivity and time. The sampling interval of the PACS 1 and 2 MicroCAT was 225 seconds. Both the PACS 2 North and South moorings had a MicroCAT placed at 80 meters. The MicroCATs deployed on the PACS 1 and 2 WHOI moorings were purchased with two titanium tabs welded to the pressure case so that the instrument could be bolted to a titanium strength member. The strength member was placed in line on the mooring.

e. Brancker Temperature Recorders

The Brancker temperature recorders are self-recording, single-point temperature loggers. The operating temperature range for this instrument is -2° to 34°C . They have an internal battery and the capability of logging 28,000 samples. A PC is used to communicate with the Brancker via serial cable for instrument set-up and data download. The PACS 1 and 2 Branckers were set to record data every 30 minutes.

A total of 30 Brancker temperature loggers were deployed on the discus moorings, with 15 on each of the buoys. Six were attached to the buoy in a near-surface temperature string, with depths ranging from .25 meters to 2.5 meters. The other nine Branckers on each mooring were dispersed at depths ranging from 7.5 meters to 200 meters.

f. Miniature Temperature Recorder

A Pacific Marine Environmental Lab (PMEL), Miniature Temperature Recorder (MTR) was mounted in line at a depth of 3.5 meters on each of the WHOI moorings. The MTR is a single-point temperature logger. System timing and sampling are controlled by an internal microprocessor. It has an internal 9-volt battery which will power the MTR for periods of greater than one year. Communication is through a serial cable using a PC. The data, as raw counts, are stored along with system software in battery backed RAM. The MTR has the capability of storing 56,800 samples of temperature. The MTRs were set up for PACS 2 to sample at a rate of 450 seconds.

g. WHOI Vector Measuring Current Meters

The Vector Measuring Current Meter (VMCM) has two orthogonal cosine response propeller sensors that measure the components of horizontal current velocity parallel to the axes of the two propeller sensors. The orientation of the instrument relative to magnetic north is determined by a flux gate compass. East and north components of velocity are computed, averaged and then stored on cassette magnetic tape. Temperature was also recorded using a thermistor mounted in a fast response pod, which was mounted on the top end cap of the VMCM. The VMCMs were set to record data every 7.50 minutes. A total of twenty VMCMs were deployed on the WHOI surface moorings, ten on each mooring, at various depths ranging from 5 meters to 110 meters. All of the WHOI VMCMs had a compass check done at the University of Hawaii Marine Center to verify that the compass was not damaged in transport. A description of how each parameter in the VMCM is sampled appears in Appendix 6.

A VMCM with new electronics and the standard orthogonal propeller sensor was deployed at 130 meters on the PACS 2 South mooring. It is the first deployment of a WHOI-upgraded instrument and is intended as a test of the new electronics. Low-power microcontroller technology is the heart of the new VMCM. The primary sub-unit in the VMCM is a vector measuring front end, consisting of rotor and compass hardware interface and a low-power microcontroller to sample these. The instrument deployed in PACS 2 has a Precision Navigation, Inc., TCM2-LP, compass which is linked via RS-232 serial interface to a PIC controller. The TCM2 is a high-performance, low-power electronic compass sensor that outputs compass heading, pitch, and roll readings via electronic interface to the host system. Data are stored on a PCMCIA "flash card" rather than cassette tape, which is standard in the older units. A standard pressure case and load cage were used for the PACS

2 deployment. Data from this instrument will be compared with data from the standard VMCM deployed at 110 meters.

h. WaDaR Temperature Recorder

All of the PACS surface buoys were outfitted with a surface-following temperature logger in order to measure sea-surface temperature. The temperature logger selected for this application was a WaDaR model TL temperature logger, manufactured by TSKA, Inc. The instrument is self-contained, with batteries, memory and a microprocessor directing operations. A PC is used to communicate with the WaDaR in order to set up the instrument for recording and to download the data. The WaDaR will record up to 65,520 temperature measurements in a single deployment. For the PACS experiment the record rate was set to 450 seconds. The WaDaR has a temperature range of -3° to $+35^{\circ}\text{C}$. The pressure case is made of titanium and is rated for full-ocean depth. The WaDaR was deployed in a molded syntactic foam float designed to follow the ocean surface. The float ran up and down along three stainless guide posts that were attached to the up-wind side (side opposite wind vane) of the discus buoy.

It was noted prior to the recovery of the PACS 2 North and South buoys that the float was freely moving up and down with each passing wave. The stainless rods were free of any growth, presumably because of the wiping action of the float. There were a few barnacles attached to the aluminum bracket on which the rods were bolted.

i. Sherman Current Meter

This instrument, developed by Russ Davis and Jeff Sherman at SIO, is an acoustic doppler current meter. Two orthogonal acoustic sensors point outward in the horizontal plane at the top of the instrument. Each sensor samples the along-beam velocity in a range bin away from the pressure case, thus avoiding eddies and other flow disturbance near the pressure case and supporting cage. A Sherman current meter was deployed on both the PACS 1 and PACS 2 South moorings at a depth of 120 meters. During PACS 1 it was bracketed by a VMCM and FSI acoustic current meter at 110 and 130 meters respectively. During PACS 2 it was bracketed by a standard VMCM at 110 meters and a VMCM with new electronics at 130 meters depth.

j. Bio-optical Package

A bio-optical package developed by Paul Fucile (WHOI) was deployed on the PACS 2 South mooring at a depth of 27.5 meters. The moored bio-optical package included a WET Labs., WETStar Miniature Chlorophyll Fluorometer; a Sea Tech, Inc., 25 cm. transmissometer; a Sea-Bird conductivity cell; a Sea-Bird temperature sensor; a LI-COR®, spherical Photosynthetically Active Radiation (PAR) sensor; as well as an upwelling PAR sensor, also by LI-COR®; and a Seapoint Sensors, Inc., turbidity meter. The instrument was controlled by Onset Computer, Corp., tattletale model 4A; and the data are stored on non-volatile PCMCIA in DOS readable files. Thus, the data can be read by a PC with a PCMCIA slot or a resident program in the logger which permits serial downloading of the data. Internal batteries provide power for deployments of up to one year. For the PACS 2 deployment the sampling interval was set at 3.75 minutes.

k. Acoustic Release

An acoustic release was used just above the anchor to release the mooring from the anchor. It was also used as a transponder to precisely locate the anchor on the bottom. The type of release used on the two WHOI moorings was an EG&G model 322.

B. Other Instrumentation

1. WHOI Shipboard Meteorological System

Following the deployment of a surface buoy and prior to its recovery, it is a common practice to position the ship approximately .25 miles downwind of the buoy so that shipboard meteorological observations can be made and compared with the data collected by the buoy. While close to the buoy its Argos transmissions can be received, decoded and compared with the shipboard observations. The comparison of data provides a means by which to check that the buoy-mounted sensors have not been damaged during deployment. Similarly if a sensor is damaged during recovery, it may not be able to be recalibrated. If accurate shipboard observations are made prior to recovery, it provides a means by which to evaluate the sensor's performance at the end of the deployment.

A shipboard IMET meteorological data recording system was mounted on the bow mast of the *Melville* to be used for intercomparison of buoy data. The IMET system recorded wind speed, wind direction, air temperature, relative humidity, barometric pressure, short-wave radiation, long-wave radiation and precipitation. The data was stored on the shipboard logging system and updated once per minute. In conjunction with the IMET system, a thermistor was mounted in the engine room salt water intake to measure sea surface temperature, which was updated every 30 seconds and stored on the shipboard logging system. Also there was a Falmouth Scientific Instruments (FSI), mounted in the bow hold attached to the ships deck. This data was updated once every 30 seconds and stored on the ships logging system.

Attached to the bow rail were two Infrared Thermometers (IRT), Model No. THI-500, manufactured By Tasco. One IRT was mounted to look up at the sky and the other was mounted to look down at the sea surface (Figure 8). An IMET relative humidity module was modified to accept the analog voltage output of the IRT sensors for signal conditioning and digital conversion. The IRT sensor module was then interfaced to the IMET logger, which polled the IRT module. Data from the IRT was sampled and stored once per minute. The IMET logger was also recording relative humidity, air temperature, precipitation and long-wave radiation at a rate of once per minute. The relative humidity, air temperature and precipitation modules were mounted on the ships forward mast. The long wave radiation sensor was mounted on the first deck forward of the wheelhouse. An external power supply was placed in the main lab to provide power to the IMET logger and the IRT sensors. Power cables and serial communications cables were run from the main lab forward to the WHOI mounted IMET system. Prior to departing the ship, data from the IMET logger was retrieved and stored on a CD-ROM disk for transport to WHOI.

Figure 8: Bow mount for infrared sea surface temperature sensor.

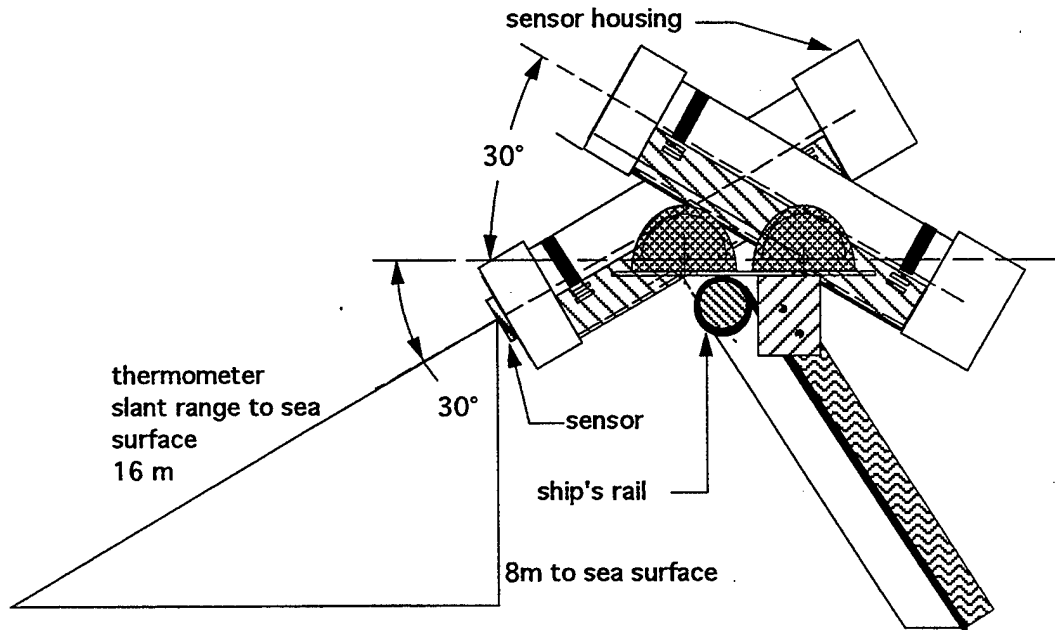

2. Chlorophyll Absorption Meter (CHLAM)

Throughout the cruise track a WET LABS Chlorophyll Absorption Meter (CHLAM) model number 9510005, serial number ACH0126 was connected to the ship's uncontaminated sea water intake in order to make running measurements of chlorophyll absorption. The data obtained was sent in real time to a 486 PC, where 120 samples were averaged into data bins. The CHLAM records a reference and a signal from three wavelengths of light; 650, 676 and 712 nanometers, and an internal temperature. With these three absorptions, it is possible to calculate the chlorophyll absorption, using: $CHL = (A_{650} + A_{712}) / 2$; where CHL is chlorophyll absorption, A_{650} , A_{676} and A_{712} are the light absorptions at 650, 676 and 712 nanometers respectively.

3. M-AERI

The M-AERI (Marine-Atmospheric Emitted Radiance Interferometer) is a well-calibrated Fourier Transform Interferometer that measures infrared spectra from about 3 to 18 micrometer wavelength. The field of view of the instrument is directed by a remotely controlled gold mirror to any direction from nadir to zenith. For this cruise it measured downwelling radiation over a set of 3 scene (zenith angles of 0, +55 and -55 degrees) and 2 calibration views. The interferometer assembly is secured on the 02 deck forward. When measuring the ocean surface it looks ahead of the bow wave to water undisturbed by the presence of the ship. The ambient-temperature and hot black body calibration targets are contained within the unit housing. This unit is connected through a set of cables to a Front End Processor in the main science laboratory. This computer derives the calibrated spectra from the raw measurements and monitors certain environmental variables — rain intensity, atmospheric pressure, relative humidity, ambient air temperature, pitch and roll as well as many variables describing the state of the instrument. The measurement sequence takes approximately 14 minutes. The M-AERI operates continuously but is protected by tarpaulins in heavy rain. The generated output includes calibrated infrared spectra and derived air and skin temperatures. These are plotted as such in real time and are archived as daily data files. Applications of the skin temperature include validating current AVHRR SST retrievals and study of the thermal skin layer at the ocean-atmosphere interface. These skin temperature data can also be used in conjunction with the air temperatures and IMET-derived winds to calculate boundary layer heat budgets.

4. Radiosondes

A total of 32 radiosonde soundings were performed during transit through the ITCZ and on post-transit clear-sky days (see Table 7). The Vaisala RS-80 radiosondes are initialized within the lab, attached to helium-filled meteorological balloons, and released on the stern of the ship. A 401MHz signal is received by an antenna mounted on the CTD hangar roof at mid-deck which is connected to a Vaisala Sounding Processor PP-15 in the main laboratory. Time, ascent rate, elevation, pressure, temperature, relative humidity, and dew-point temperature are output to a laptop PC configured with PC-PLOT to log the data stream to file. At some pressure level, the balloon bursts and the processor acknowledges 'Sounding Stop Detected'. Graphical representations of the output are made using MATLAB, and consist of two formats — traditional xy plots and interpolated transit sections of temperature, dewpoint temperature, and relative humidity (Figure 9).

Table 7: Radiosonde Log**PACS 03 Radiosonde Log**

File Number	Date	Time (GMT)	Latitude	Longitude	Max. Elevation (km)	Min. Pressure (mb)
980911.a	9/11/98	01:13	21 39.01 N	120 59.97 W	19.790	58.5
980913.a	9/13/98	12:14	10 56.47 N	124 54.99 W	13.560	166.9
980913.b	9/13/98	16:19	10 13.65 N	125 14.10 W	18.669	69.2
980913.c	9/13/98	19:47	9 57.33 N	125 22.35 W	19.827	57.5
980913.d	9/14/98	00:51	9 56.99 N	125 23.12 W	21.755	41.8
980913.e	9/14/98	03:54	9 56.98 N	125 23.10 W	5.188	544.9
980913.f	9/14/98	08:02	9 56.98 N	125 23.10 W	17.084	91.9
980913.g	9/14/98	12:06	9 56.98 N	125 23.11 W	1.493	850.3
980915.a	9/14/98	23:46	9 53.51 N	125 20.23 W	20.198	53.9
980915.b	9/15/98	12:03	9 00.00 N	124 59.99 W	13.889	157.7
980916.a	9/16/98	00:10	7 26.22 N	125 00.07 W	1.700	924.0
980916.b	9/16/98	11:59	5 28.60 N	125 00.10 W	15.590	118.3
980917.a	9/16/98	23:59	3 52.16 N	125 00.06 W	17.653	82.9
980917.b	9/17/98	11:57	2 24.32 N	125 00.03 W	20.474	51.4
980917.c	9/17/98	15:52	1 49.01 N	125 00.26 W	19.562	60.2
980917.d	9/17/98	19:52	1 19.37 N	125 00.20 W	22.310	38.3
980917.e	9/17/98	23:46	0 51.12 N	124 59.99 W	18.649	70.5
980917.f	9/18/98	03:51	0 17.49 N	124 59.94 W	13.286	175.3
980917.g	9/18/98	07:50	0 08.64 S	125 00.08 W	17.859	80.7
980917.h	9/18/98	12:18	0 39.20 S	124 59.98 W	18.926	67.0
980919.a	9/18/98	23:51	2 08.97 S	125 00.75 W	21.399	44.2
980919.b	9/19/98	11:56	2 46.82 S	124 42.95 W	17.064	91.6
980919.c	9/19/98	15:50	2 46.94 S	124 41.46 W	19.150	64.5
980919.d	9/19/98	19:48	2 46.57 S	124 42.34 W	21.432	43.9
980919.e	9/19/98	23:47	2 46.83 S	124 41.67 W	25.615	22.5
980919.f	9/20/98	03:43	2 46.83 S	124 41.67 W	21.531	43.2
980919.g	9/20/98	07:55	2 46.83 S	124 41.67 W	22.614	36.3
980919.h	9/20/98	11:54	2 46.83 S	124 41.67 W	19.624	59.4
980922.a	9/22/98	15:29	2 48.72 N	124 29.69 W	13.334	173.2
980923.a	9/23/98	20:04	8 59.96 N	123 22.59 W	24.227	28.1
980924.a	9/24/98	20:06	14 08.56 N	122 25.97 W	25.132	24.7
980925.a	9/25/98	16:44	18 34.04 N	121 37.31 W	20.641	50.7

Figure 9: Radiosonde Sounding Plot

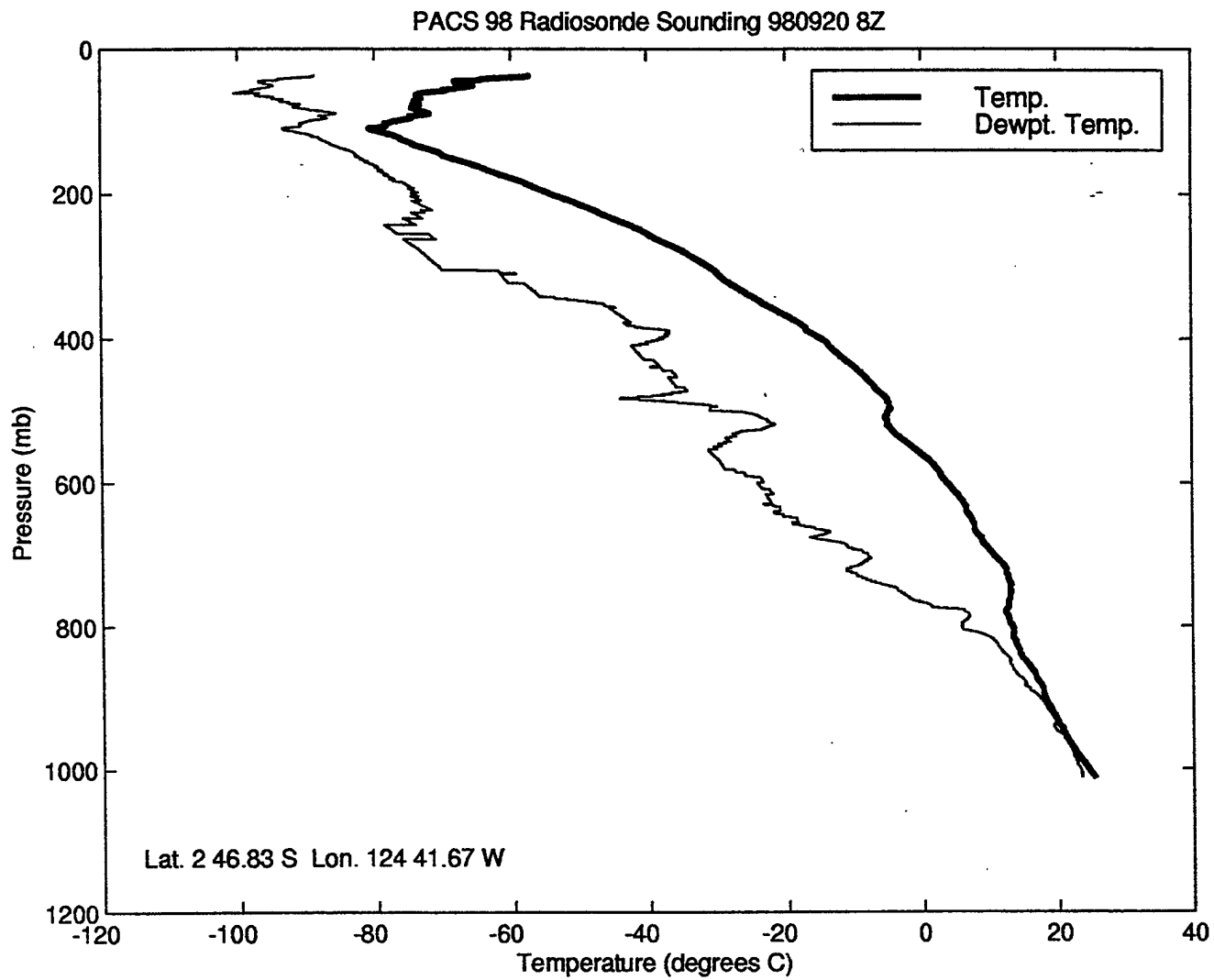

5. Hard Hat SST

The hard hat SST measurement device uses a thermistor at a depth of a few centimeters below the sea surface to measure the bulk, in situ temperature. Hard foam that fills the remaining volume of the hat aids in maintaining positive buoyancy. A Hewlett Packard 34401A Multimeter located on the main laboratory bench samples the resistance over 10 second intervals and outputs the data to a laptop running QBASIC. Calibration coefficients within the QBASIC program `dvm_log.bas` are used to make the final conversion from resistance to SST. This method of sampling SST can only be used on station and when the ship is travelling at speeds less than 1 knot. Table 8 contains the deployment times and positions.

6. ALL-SKY Mirror

Mounted on the O3 deck just forward of the pilot house is a convex dome mirror anchored to a sheet metal base. Suspended above the mirror on an i-beam is a Sony video camera which records video of the dome of the sky reflected at the mirror surface. Every 17 minutes the image is recorded by a time-lapse VCR unit in the scientific chart room. The collection of these images gives an idea of the percent cloud cover, cloud type, and precipitation.

7. SOLO Drifters

The Sounding Oceanographic Lagrangian Observer (SOLO) (Figure 10) is a neutrally buoyant float used to measure the ocean's currents. The float self-ballasts to the desired neutral depth, drifts with the local currents, and after a pre-set time (typically 5-30 days) adds buoyancy to ascend to the surface, transmit information via Argos satellite, and then returns to its neutral depth. The cycle is repeated until the batteries die (~200 cycles). During ascent/descent temperature (and optionally conductivity) profiles are recorded for satellite transmission as well. Additionally, the float can be equipped with a vane, causing it to spin when there is vertical flow past the SOLO. This Vertical Current Meter (VCM-SOLO) transmits the time series of T, P, and vertical velocity as measured while at its neutral depth. Four VCM-SOLOs (designated by "VT" following their serial number), and four Temperature-Profiling SOLOs (designated by "T" following their serial number), were deployed during PACS03MV cruise. Table 9 lists the deployment locations for the four SOLO floats deployed during PACS03MV.

At the equator, four VT models were deployed in two separate groups two at a time. SOLO's 1093 and 1095 were deployed on the southbound leg of the cruise with 1093 programmed to dive shallow and 1095 programmed to dive deep. These SOLO's are measuring the vertical currents associated with the equator. Shallow diving SOLO 1094 and deep diving SOLO 1096 were deployed four days later at the same position in an effort to see time dependencies of the vertical equatorial currents.

CTD casts were performed prior to and at the same positions as SOLO's 1093, 1095, 1101, 1002, 1094, 1095.

Table 8: Hard Hat SST Log

PACS 03 Hard Hat SST Log

File Number	Date	Start Logging Time (GMT)	End Logging Time (GMT)	Latitude	Longitude	Average SST (C)
980911a.hat	9/11/98	17:17:58	18:10:09	18 24.08 N	122 07.35 W	25.6467
980912b.hat	9/12/98	18:11:14	18:33:41	13 59.59 N	124 37.59 W	26.5014
980913a.hat	9/13/98	18:20:40	20:25:58	09 57.20 N	125 22.20 W	26.4067
980915a.hat	9/15/98	13:01:49	13:28:50	09 00.00 N	124 59.58 W	26.5018
980915b.hat	9/15/98	19:28:25	20:14:53	07 59.00 N	124 59.58 W	26.7376
980916a.hat	9/16/98	02:19:36	02:40:20	06 59.57 N	125 00.05 W	26.6170
980916b.hat	9/16/98	14:20:11	14:51:09	05 00.01 N	124 59.58 W	26.5616
980916c.hat	9/16/98	21:52:01	22:27:41	04 00.02 N	125 00.02 W	25.7701
980917a.hat	9/17/98	01:47:19	02:20:23	03 29.58 N	125 00.01 W	25.8626
980917c.hat	9/17/98	10:03:32	10:13:43	02 30.20 N	125 01.03 W	25.5329
980919a.hat	9/19/98	01:36:42	01:56:34	02 30.06 S	125 00.03 W	24.1444
980919b.hat	9/19/98	18:19:25	18:50:23	02 46.33 S	124 42.24 W	24.3888

Figure 10: Schematic of a SOLO Drifter.

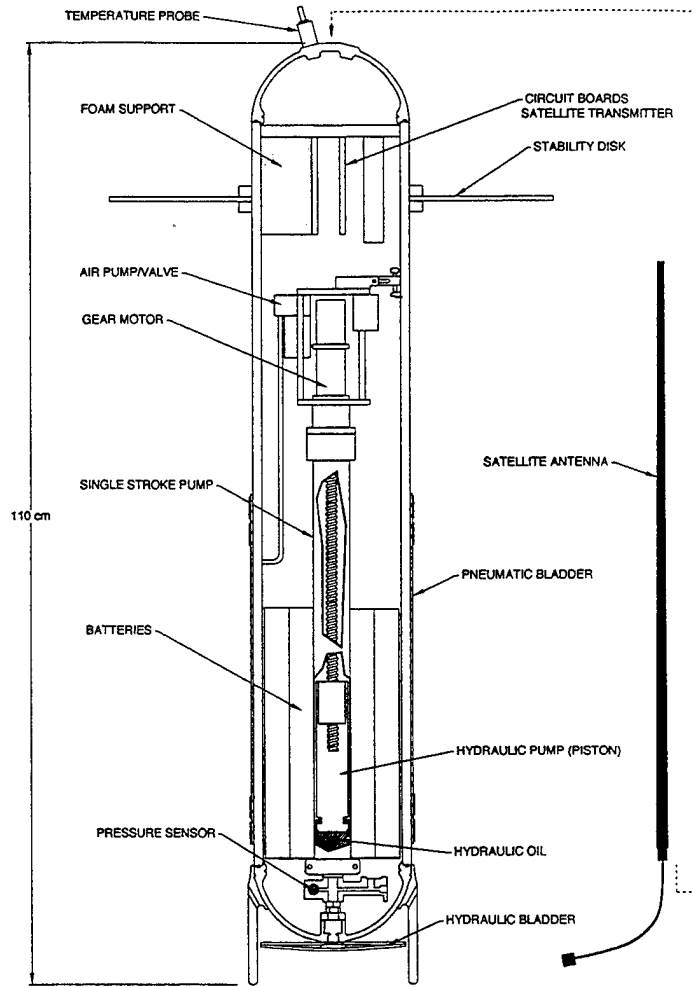

Table 9: SOLO Drifters deployment times and positions.

S/N	Type	Deployment Time	Deployment Date	Latitude	Longitude	Notes
1100	T-Profiler	0422 GMT	12-Sep-98	16-30.227'N	122-46.080'W	
1103	T-Profiler	1846 GMT	12-Sep-98	14-00.001'N	123-38.117'W	Line fouled Temp.
1093	VT	0635 GMT	18-Sep-98	00-00.031'N	125-00.064'W	Surface currents strong
1095	VT	0637 GMT	18-Sep-98	00-00.006'S	125-00.092'W	Surface currents strong
1101	T-Profiler	1437 GMT	18-Sep-98	01-00.173'S	124-59.989'W	Line fouled Temp.
1102	T-Profiler	0558 GMT	19-Sep-98	03-00.181'S	124-59.904'W	Surface current about 1 knot-NNE
1094	VT	0105 GMT	22-Sep-98	00-00.095'N	125-00.095'W	
1096	VT	0106 GMT	22-Sep-98	00-00.130'N	125-00.114'W	

Section 3: Cruise Chronology

Staging in San Diego

The equipment needed to recover the surface mooring was sent to the Nimitz Marine facility in Pt. Loma, California from WHOI in late August 1998. Most of the cruise participants arrived in San Diego on 3 September 1998 and were ready to work loading the ship on September 4, 1998. The Resident Technician, R. Comer, loaded the soft-top "Ball Van" onto the *Melville*. P. Minnett (U. Miami) had arrived a few days earlier and had prepped M-AERI for the cruise. During the next three days everyone worked to load the ship and prepare the deck, main lab and instruments for the cruise. The TSE winch and tuggers were all secured to the fantail, All deck gear was spotted and lashed in place. The M-EARI, Floating SST and the bow IR-SST and Humidity system were set up near the bow and cables run back to the main lab. The Main Lab was set up with computer systems and electronics in preparation for instrument servicing and downloading. Antennae were mounted for Argos, GSP and Vaisala radiosonde system. Helium was loaded for radiosondes. J. Dufour (SIO) and B. Jones (SIO) loaded 8 SOLO floats (four were Vertical Current Meters (VCM-SOLO)) from R. Davis into the main lab that were deployed by Jones during the cruise.

The following instrumentation was staged on *Melville* at the dock to collect continuous data during the trip. The ship's data collection system consisted of a complete IMET package on the bow mast, an FSI temperature and conductivity sensor in the seawater intake at the bow approximately 3.5 m below the surface, a thermistor on the seawater intake in the engine room, P-code GPS and inertial navigation system. An additional meteorological package was added and referred to from now on as the bow system. Initially this package consisted of an IMET data logger, an IMET RH module mounted on the mast just below the *Melville's* IMET RH module, a pair of up and down looking TASC0 infrared thermometers, a power and serial cable back to the main lab and a PC and power supply in the main lab. A WetLabs CHLAM and logging computer were connected to the uncontaminated seawater supply in the photo lab to monitor surface chlorophyll. M-AERI was staged on the 02 deck near the starboard bow. The All-Sky Camera was mounted on the deck in front of the pilot house with the video recorder in the Scientific Map Room on the 02 deck. At the request of S. Smith (SIO) the SeaBeam system was activated and recorded data during the whole cruise while the ship was outside the Mexican EEZ. Smith requested the ship to go through two way points on route to the Northern mooring site (WP1 25° 45'N; 119° 38'W; WP2 20° 0' N; 121'W).

Transit to 10°N

The *Melville* departed from San Diego at 0800 (local) 8 September 1998 and headed into calm seas and overcast conditions. Seawater pump was turned on and all underway gear was logging by 1500 of the departure day. At 1400, W. Ostrom holds his first of several Deck Orientation classes on the fan tail. These classes are designed to make the members of the science party familiar with the winch and tugger operation and trained to work as a team so they are prepared for the mooring recovery operations. At 1700, the first radiosonde is launched but the telemetry fails and no data is collected.

On 9 September 1998, PMEL informs the *Melville* the R/V *Ka'imimoana* will be servicing the 125°W TAO mooring line the same time the *Melville* will be there. The second radiosonde is launched but still the telemetry fails. At 2000, the *Melville* departs Mexican EEZ and the SeaBeam and ADCP are turned on. On 10 September 1998, in an effort to

sort out the problems with the radiosonde system, a balloon is tethered to the A-frame. After some time, the deck unit finally locks into the sonde. The balloon was then cut free and the first profile is obtained. At 1930, the *Melville* came to all stop to bury at sea a former crew member.

The *Melville*'s electrician discovers a ground loop in the main lab on the morning of 11 September 1998. In a search for the ground loop, all underway instruments are turned off and disconnected one by one. At 1000, the bow system was shut down but would not restart properly and the IR-SST system would not respond. After several hours of work, the system was up and running by 1530. The ground loop turned out to be caused by a leak from the sea water system into the ship's Doppler speed log. At 2200, the first SOLO float was deployed at 16.5°N. On 12 September, problems with the bow system persist and replacing the batteries in the TASC0 IR thermometers seemed to fix the problem. The ship stops at 1000 for a CTD cast to 1000 m to test the CTD system which worked just fine.

The Northern Mooring.

The *Melville* was still in transit due to arrive at the mooring on 13 September 1998. At 0500 on 13 September 1998, the first radiosonde was launched to start a 24 hour enhanced sampling with sondes every 4 hours. The buoy was spotted at 1000 and the ship went along side for a visual inspection at 1030. Argos telemetry is picked up from both the IMET and VAWR but the IMET does not have any data. The *Melville* moved down wind of the buoy approximately 1 nm and put the bow into the wind. At this time hand held meteorological observations began and continued every hour until 0500 the next morning. A CTD cast was taken to 4000m. At 1500, the *Melville* moved to within 0.25 nm of the buoy and the small boat was put into the water. The boat did a close visual inspection of the buoy. The buoy looked in good shape; cups, vane and prop all were still rotating and the floating SST still moved freely up and down. The water line was approximately 12 inches from deck and water did splash on the deck.

Conditions were rainy during the met intercomparison making for poor conditions for hand held met inter-comparison at times. The ship's IMET was not logging any rain so a second rain gauge was mounted approximately 2 m up the bow mast and tied into the bow system. It was filled with water to fill its reservoir. The ship's SST sensor on the bow intake failed during the intercomparison and never returned good data for the rest of the cruise. The CHLAM was shut down, cleaned out and an in air calibration was performed. This looked worse than the clean water calibration that was performed prior to departure and was considered no good. At 1830, we met with the Captain to review the mooring recovery plan.

At 0600 on 14 September 1998, the *Melville* moved up wind and current of the anchor location. The release was fired at 0730 and the balls were on the surface 50 minutes later. The winds were 5—10 knots and there was very low cloud cover. There was 1.5 inches of rain from the time the release was fired until 1100. The mooring was recovered and was on deck by 1500. During the buoy recovery, the lifting sling got snagged on the VAWR air temperature arm. This ended up snapping off the VAWR RH and air temperature sensors. All instruments were recovered except the four deepest Brancker t-pods on the near surface array. It appeared that the brackets were sheared off sometime long before recovery. No other damage and no fishing gear was found on the subsurface instruments. All instruments are labeled and photographed before being cleaned.

Transit to southern mooring site

After the mooring recovery, the *Melville* worked south along 125°W. We conducted a hydrographic transect along the way. On 15 September at 0600, the first CTD station on the transect was conducted. As we continued working down 125°, wire was spooled off the winch and bundled (in the rain). The VMCM's were uncaged. The T-pods and SEACAT data were dumped. We encountered more and more rain and low clouds all day. We held CTD training classes and resumed watches. The science party was a bit tired from the day before. The Captain informed us that 1200 on 22 September will be the cut off for science and we will head home.

On 16 September, we continued moving south along 125°W. After 5°N, we did a CTD every 0.5° to 1000m. The rain stopped in the morning and skies began to clear. The humidity dropped in the afternoon as cumulus clouds became scattered and high stratus clouds became visible. The winds strengthened to 15-20 knots from southeast. The spare LW sensor was mounted on the 02 deck morning and it logged to the bow system. All the VMCM tapes were pulled and read and the VMCM's were recaged. Data from the Standalone rain gauge and ASIMET RH for the northern mooring were dumped. The buoy well was found to be dry and in good condition. The R/V *Ka'imimoana* called the *Melville* in the morning and Linda Mangum (PMEL) sent an email describing their plans. The *Melville* was scheduled to pass them working on the Atlas at 2°N early on 17 September but we will likely not see them. Their mooring was 20 nm west of its station and off our track. The science crew were well trained on CTD and the watches go it alone tonight.

On 17 September, we continued CTD transect and conducted sondes every 4 hours for diurnal cycle. The surface currents were very strong towards the west at some stations and drove some large wire angles on the CTD. The northern mooring IMET dumped data but only data up to the beginning of April. The disk/serial I/O controller board had to be replaced in order to talk to it at all. The VAWR tape was read with few errors. Data from all the instruments on the North mooring were dumped. The VMCM's were boxed and stowed. The ship's SST was still not working. We placed the Wadar-272 on the hull in the bow dome and put insulation behind it. It would provide a measure of SST because nothing else was working. Even the U. Miami "Hardhat" SST had failed. Kay had trouble with M-AERI nitrogen purge. She did not seem to have the correct connector.

The *Melville* crossed the equator very early on 18 September. Brent Jones dropped in two of Davis' vertical velocity SOLO floats on the equator. He also put a profiling float at 1° S as well. The hydrographic survey continued. The buoy hull and tower were moved to starboard rail. All hardware had been cleaned. Lord and Kay put new thermistor in Hardhat SST. Way works with the Chief Engineer to make a fitting so Erica can do the nitrogen purge and the purge was successful. At 1600, the NOAA *Ka'imimoana* was spotted off to port about 4 nm servicing the TAO buoy at 2°S. The transit was completed at 2300 with the last station at 3°S.

The southern mooring site.

We arrived at the southern buoy on 19 September at 0200 and began handheld met observations at 0500 as well as did soundings every 4 hours. The *Melville* steamed by the buoy at 0830 for inspection then we put in the small boat with Ostrom and Anderson for a closer look. Argos was received locally on the ship from the VAWR but not IMET. The light on the buoy had failed. We conducted a CTD cast to 4000m that ended at 1230. Then the group relaxed a bit. The crew made a tub with a tarp and wire basket filled with sea water and soaked in it most of the afternoon. The hand met observations and soundings continued throughout the night.

On 20 September at 0600, the soundings and met observations stopped and the ship moved off and into position to fire the release. Way attempted to talk to the release with the 8011A deck unit, without much luck since the ship was in dynamic positioning because the current was strong. We requested the bridge to declutch the drive so we would drift. Still there was only a faint reply from the release. We switched to the older 8011 and succeeded in talking to the release and fired it at 0730. At 0830 the balls were spotted and we approached to begin the recovery. The swell was quite a bit larger than we had encountered during the first recover but we finally managed to grapple for the balls and haul them on-board. The recovery continued and again we used the small boat to assist with the buoy recovery. The buoy was finally on deck around 1530 with just minor damage to the sun shields on the near surface temperature array on recovery. There were no visual signs of vandalism. The lowest T-pod on the near surface array was missing and appeared to have been gone for some time. The bio-fouling was slightly less on this mooring than at PACS North but the barnacles seemed to be larger. The VAWR cups were frozen and the IMET prop bearings were missing. The Young prop and vane were very loose but still spinning. The buoy deck had a green algae growing on it. We continued on and cleaned up the instruments, bridle and deck and finished up around 2100. The fishing that night was very good with tuna and mahi jumping everywhere.

Transit back to San Diego

We cruised close by the Atlas buoy at 2°S for inspection on 21 September at 0700. It was supposed to be a new generation type but looked the same as the old ones and no solar radiation sensor was visible. The crew were a bit tired from the day before. The wire and rope was spooled off the winch and the VMCM's were uncaged. The radiation shields from temp array were scrubbed and cleaned. We opened the buoy well and found it dry inside so we closed it up. Way successfully talked to the IMET but the IMET Argos module did not respond. This was good news since it was likely the IMET recorded data. We bagged the solars and ice bathed the T-pods and SEACATs. We removed the R. M. Young vane because we are afraid it would fall apart and we wanted to return it to the lab in one piece for calibration. Way and Furey began dumping the Brancker T-pods. At 1800, Jones put in the last two SOLO floats, the vertical velocity kind, at the same spot on the equator at 125°W. In the evening, we cleaned up the lab a bit and regrouped. The *Melville* began the trip back to San Diego.

On 24 September we returned to the trades again with the wind blowing stiffly 15-20 kts. The seas had come up but the swell was not too large. Today we removed the tower and bridle from the buoy. South IMET data was successfully dumped and the VMCM tapes were all read. We figured out the shipboard IMET data format and corrected it for ships motion. The ADCP failed during the night with the warning light indicating a hardware failure. After 12 hours the computer tech tried it again and it started working. Ship's IMET wind module kept locking up, either repeating the same number or giving bad values. We tried to cycle the power to get it going again when this happened. The bow IR SST went bad and the down looking IR was no longer recognized by the bow logger even though the actual sensor looked just fine. There was a little water in the up looking unit but it seemed to be just fine. Way took apart the logger and put it back together and it started working at 1400. No reason for the failure found. All VMCM and VAWR tapes have been read and the Standalone precipitation gauge data was dumped. ASIMET R/H and new VMCM will not dump data. We pulled the PC-card from VMCM and took it home to Hosom. The Tension and Optics packages were still dumping data.

The ADCP was working again on 25 September at 0900. The ADCP just came back to life after being off for 12 hours. The weather was fair with scattered cumulus. Last

sounding was taken. The *Melville's* IMET winds continue to lock up and need to be reset every few hours. At 2200, we entered Mexico EEZ and stopped logging ADCP and SEABEAM data. The Bio-Optics data finally had been dumped. On 26 September, the Pollywogs were initiated. All underway equipment continued without a problem. On 27 September, we began to pack up the lab. All mooring and shipboard data were placed in directory on the ship's main computer ready to be archived to CD-ROM. Underway data for ADCP was still going strong. We made vu-graphs of data for R. Weller to take to the PACS PI meeting. On 28 September, we were met off the coast of San Diego by a group of SeaBeam Technicians. They conducted tests on the SeaBeam system all night. The R/V *Melville* arrived back at the dock in Point Loma at 1300 on 29 September 1998.

Acknowledgments

The WHOI moorings were designed by George Tupper, and, as always, were carefully prepared by the WHOI Mooring and Rigging Shop under the watchful supervision of Dave Simoneau. We thank Captain Buck and the crew of the R/V *Melville* for their professional operation of the ship and support of the science party at sea.

This work was supported by the National Oceanic and Atmospheric Administration Grant No. NA66GP0130.

References

- Falmouth Scientific, Inc., 3-D Acoustic Current Meter, 3-D-ACM, Version 6.0, Firmware Version 2.54, Operating Instructions, 126 pp.
- Trask, Richard P., Bryan S. Way, William M. Ostrom, Geoffrey P. Allsup, and Robert A. Weller, 1995. Arabian Sea Mixed Layer Dynamics Experiment, Mooring Deployment Cruise Report, R/V *Thomas Thompson* Cruise Number 40, 11 October - 25 October 1994. Upper Ocean Processes Group, UOP Technical Report 95-1, Woods Hole Oceanographic Institution Technical Report, WHOI-95-01, 64 pp.
- Trask, Richard P., Robert A. Weller, William M. Ostrom and Bryan S. Way, 1998. Pan American Climate Study (PACS). Mooring Recovery and Deployment Cruise Report, R/V *Thomas Thompson* Cruise Number 73, 28 November to 26 December 1997, Upper Ocean Processes Group, UOP Technical Report 98-02, Woods Hole Oceanographic Institution Technical Report, WHOI-98-18. 107 pp.
- Trask, Richard P. and Robert A. Weller, 1995. Cyclic Fatigue Testing of Surface Mooring Hardware for the Arabian Sea Mixed Layer Dynamics Experiment. Upper Ocean Processes Group, UOP Technical Report 95-15, Woods Hole Oceanographic Institution Technical Report, WHOI-95-16, 63 pp.
- Way, Bryan S., William M. Ostrom, Robert A. Weller, Jonathan D. Ware, Richard P. Trask, Rick Cole, and Jeff Donovan, 1998. Pan American Climate Study (PACS), Mooring Deployment Cruise Report, R/V *Roger Revelle*, Cruise Number Genesis 4, 9 April - 5 May 1997. Upper Ocean Processes Group, UOP Technical Report 98-01, Woods Hole Oceanographic Institution Technical Report 98-07, 71 pp.

Appendix 1 Cruise Participants

Woods Hole Oceanographic Institution

Steven Anderson (Chief Scientist)
Peter Furey
Jeff Lord
William Ostrom
Bryan Way
Shuliang Zhang

Scripps Institution of Oceanography

Brent Jones

University of Concepción, Chile

Carolina Parada
Gabriel Yuras

University of Miami

Erica Kay
Jeremy Pennington

University of California Santa Barbara

Mike Bernstien

Appendix 2 PACS 2 Recovery Cruise CTD Stations

Table A2-1: CTD stations taken during PACS03MV

	DATE dd/mm/yy	FILE ID.	WAIN START	START TIME (UTC)	START LAT.	START LON.	WIRE OUT (M)	STOP TIME (UTC)	STOP LAT.	STOP LON.
0	11-Sep	pacs0300.hex		17:16	18 24.13 N	122 07.59 W	1000	18:01	18 24.132 N	122 07.59 W
1	12-Sep	pacs0301.hex	8.4*	17:45	14 00.01 N	123 38.06 W	1001	18:33	13 59.99 N	123 37.99 W
2	13-Sep	pacs0302.hex	8.1	18:20	09 57.33 N	125 22.35 W	4000	19:48	09 57.33 N	125 22.35 W
3	15-Sep	pacs0303.hex	8	10:06	08 59.99 N	124 59.99 W	1000	13:34	08 59.99 N	124 59.99 W
4	15-Sep	pacs0304.hex	7.9	19:22	08 00.01 N	124 59.99 W	1000	20:27	08 00.09 N	124 59.99 W
5	16-Sep	pacs0305.hex	8.6*	1:50	06 59.94 N	125 00.08 W	998	2:53	06 59.90 N	125 00.15 N
6	16-Sep	pacs0306.hex	8.2	8:05	05 59.72 N	124 59.87 W	999	8:54	05 59.73 N	124 59.80 W
7	16-Sep	pacs0307.hex	8.2	14:20	05 00.00 N	124 59.99 W	1000	15:20	05 00.00 N	124 59.99 W
8	16-Sep	pacs0308.hex	8	18:13	04 30.20 N	125 00.127 W	1000	18:58	04 30.20 N	125 00.12 W
9	16-Sep	pacs0309.hex	7.9	21:52	04 00.02 N	125 00.06 W	1000	22:53	04 00.04 N	125 000.5 W
10	17-Sep	pacs0310.hex	7.8	1:45	03 29.98 N	125 00.04 W	1000	2:33	03 29.98 N	125 00.10 W
11	17-Sep	pacs0311.hex	7.8	5:37	03 00.42 N	125 00.56 W	1000	6:26	03 00.42 N	125 00.56 W
12	17-Sep	pacs0312.hex	7.7	9:54	02 30.27 N	125 00.88 W	1000	10:43	02 30.35 N	125 01.32 W
13	17-Sep	pacs0313.hex	7.7	14:05	01 59.94 N	124 59.95 W	180	14:22	02 00.08 N	125 00.81W
14	17-Sep	pacs0314.hex	7.7	17:34	01 29.99 N	125 00.14 W	1000	18:24	01 29.90 N	125 00.00 W
15	17-Sep	pacs0315.hex	7.6	21:34	01 00.19 N	125 00.23 W	1000	22:24	01 00.19 N	125 00.20 W
16	18-Sep	pacs0316.hex	7.6	1:30	00 30.07 N	124 59.88 W	1000	2:20	00 30.17 N	124 59.98 W
17	18-Sep	pacs0317.hex	8.6*	5:34	00 00.08 N	125 00.03 W	1000	6:24	00 00.07 N	125 00.03 W
18	18-Sep	pacs0318.hex	8.4	9:45	00 29.83 S	125 00.15 W	1000	10:33	00 29.45 S	125 00.67 W
19	18-Sep	pacs0319.hex	8.2	13:36	01 00.01 S	124 59.90 W	1000	14:24	01 00.01 S	124 59.92 W
20	18-Sep	pacs0320.hex	8.1	18:18	01 29.97 S	125 00.06 W	1000	19:06	01 29.97 S	125 00.06 W
21	18-Sep	pacs0321.hex	8	22:00	02 00.11 S	125 00.11 W	1000	22:46	02 00.08 S	125 00.18 W
22	19-Sep	pacs0322.hex	7.9	1:29	02 30.12 S	125 00.07W	1000	2:17	02 30.10 S	125 00.06 W
23	19-Sep	pacs0323.hex	7.8	5:04	03 00.17 S	124 59.91 W	1000	5:53	03 00.18 S	124 59.91 W
24	19-Sep	pacs0324.hex	7.9	16:54	02 46.55 S	124 42.38 W	4000	19:30	02 46.55 S	124 42.38 W
			* new battery							

Figure A2-1: Chart showing CTD station locations.

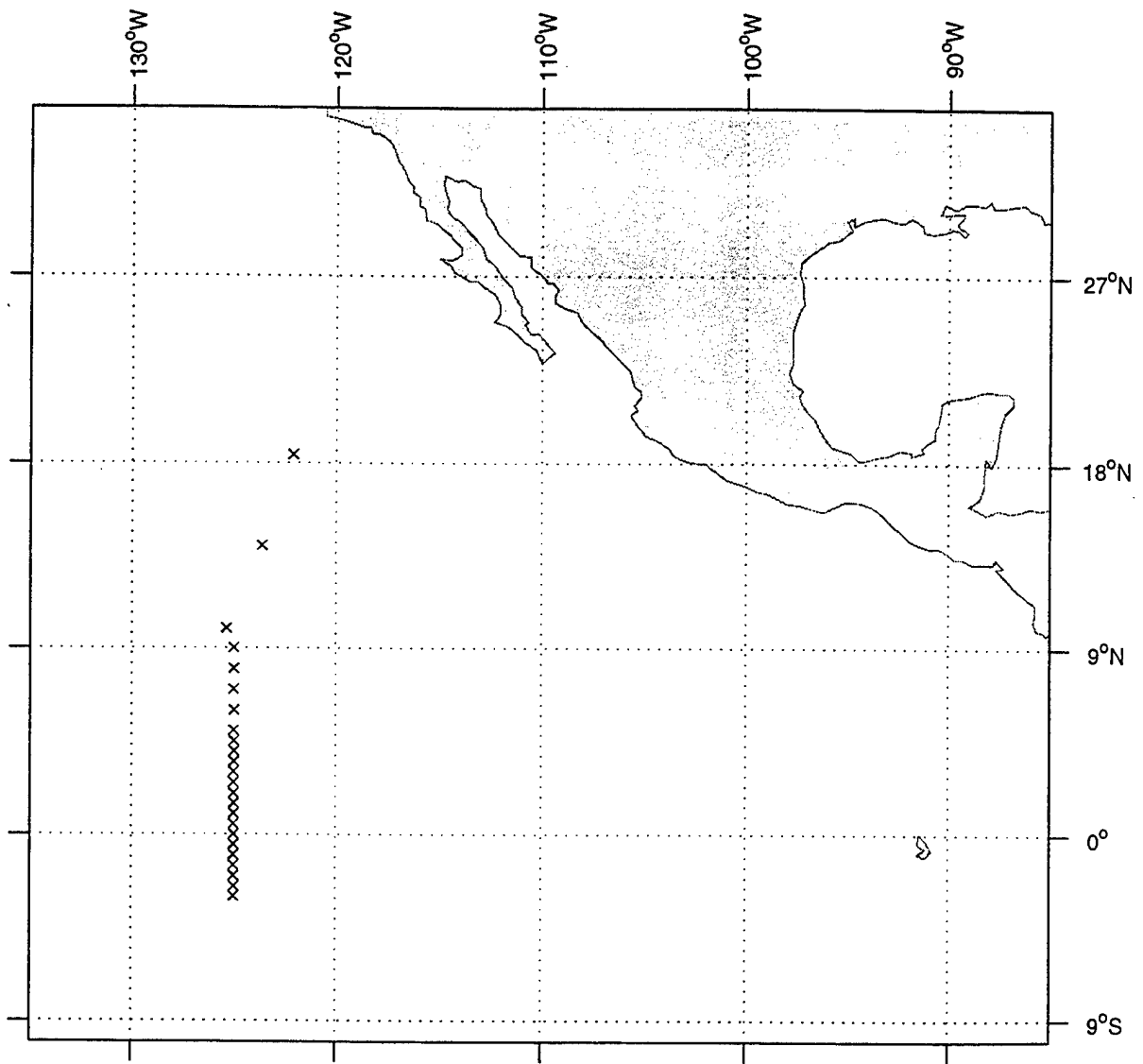

Figure A2-2: Composite plot of CTD data taken during PACS03MV

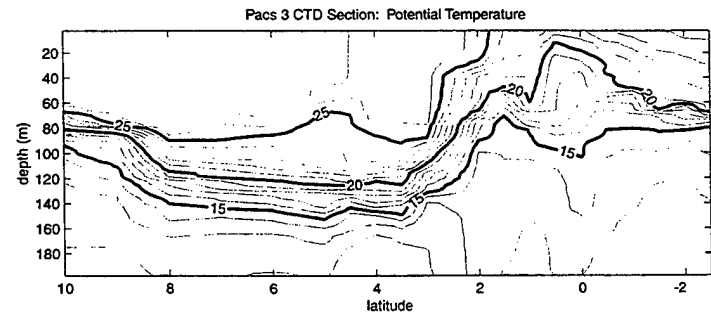
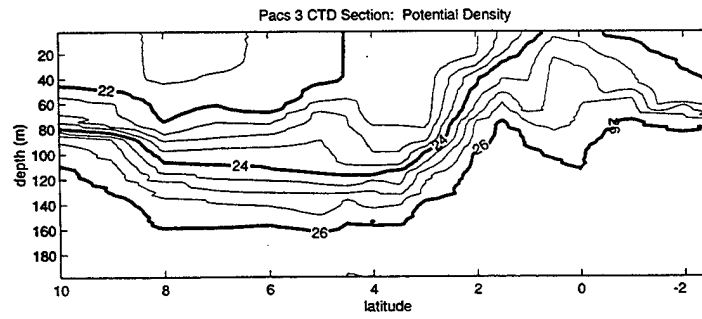
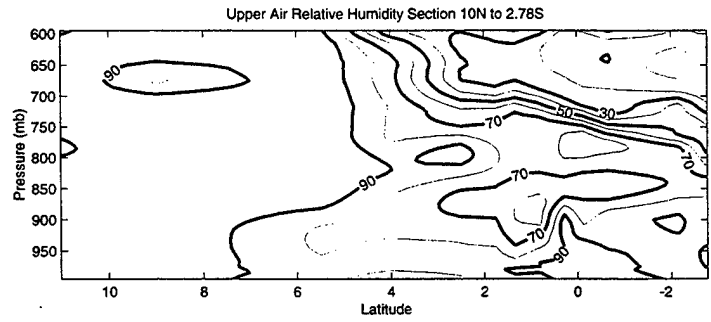
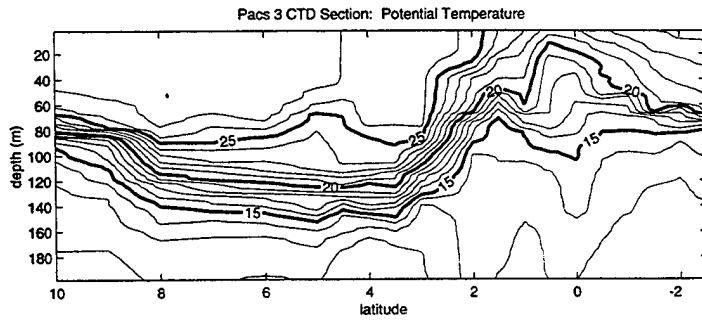
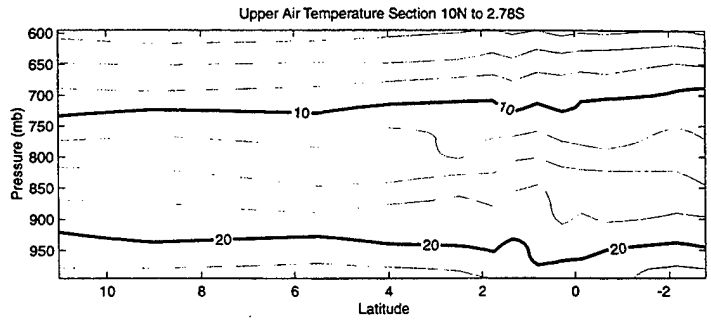
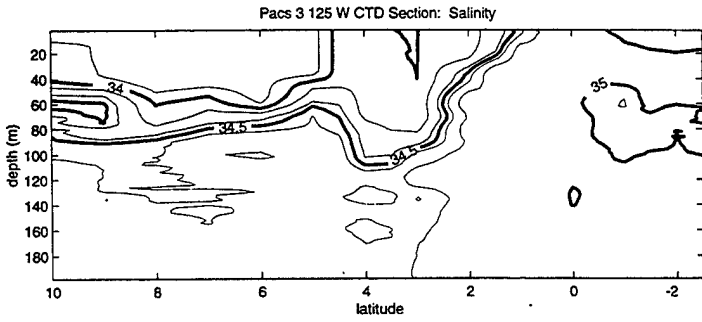

Figure A2-3: Profiles from CTD stations 1 and 2.

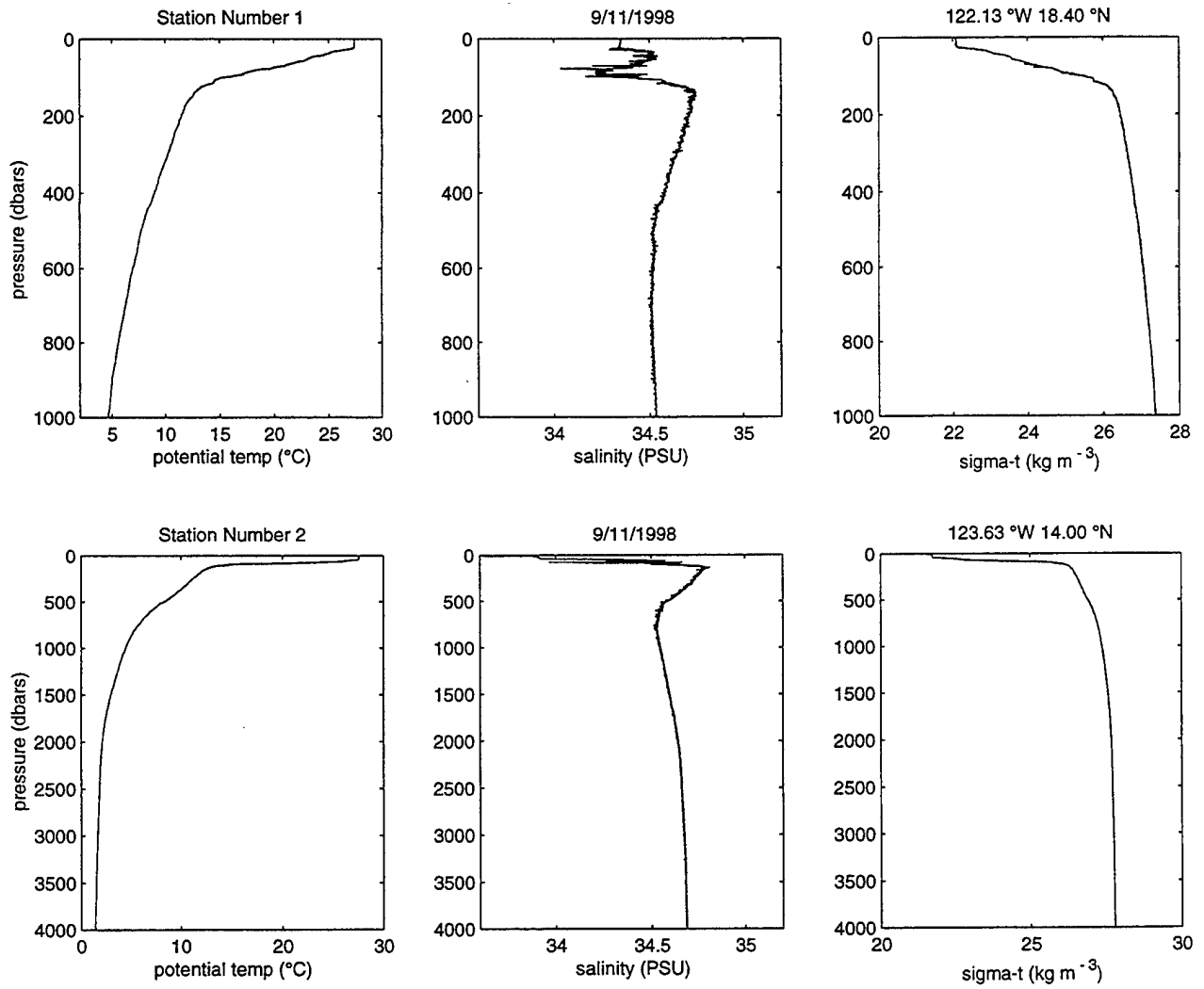

Figure A2-4: Profiles from CTD stations 3 and 4.

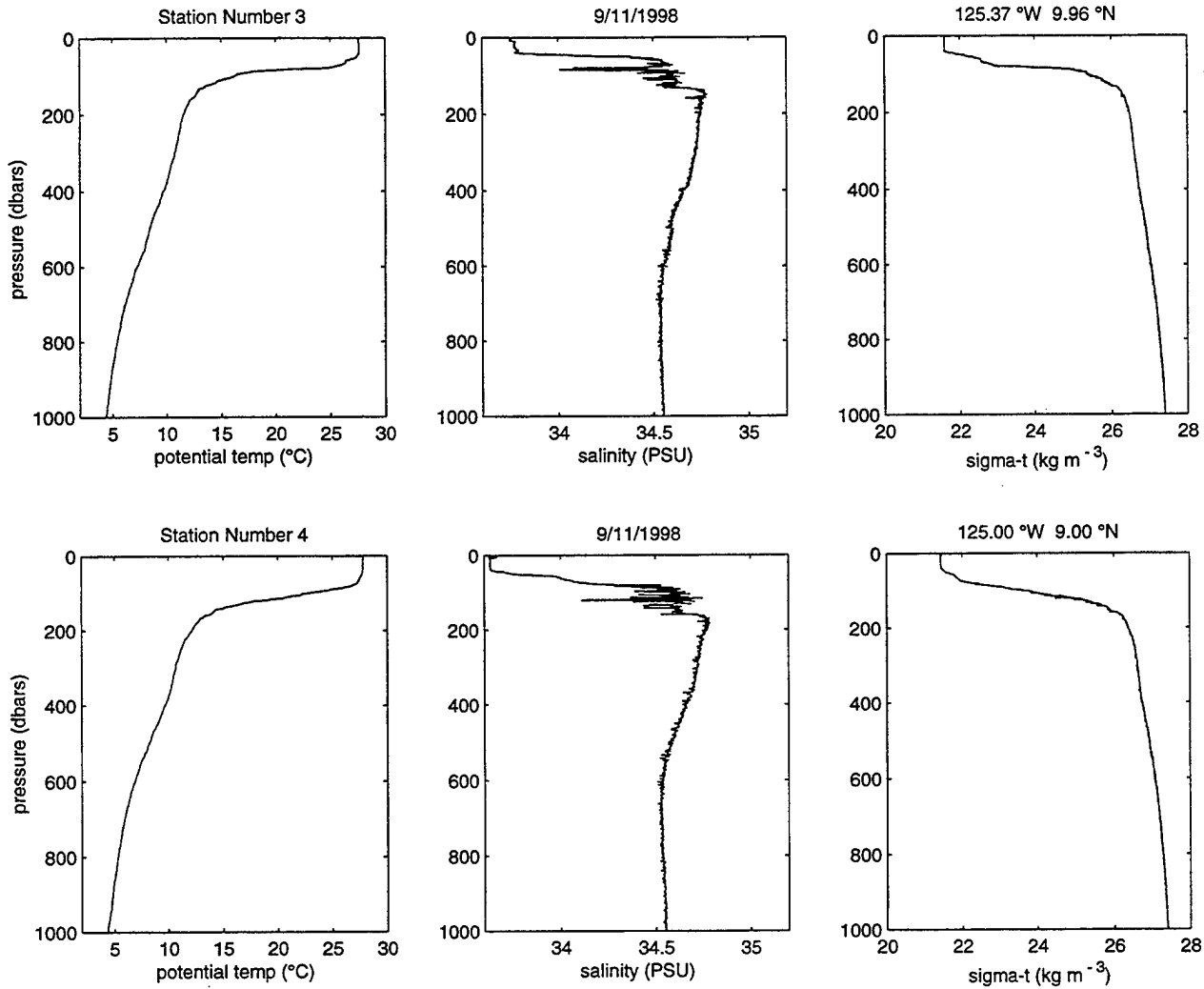

Figure A2-5: Profiles from CTD stations 5 and 6.

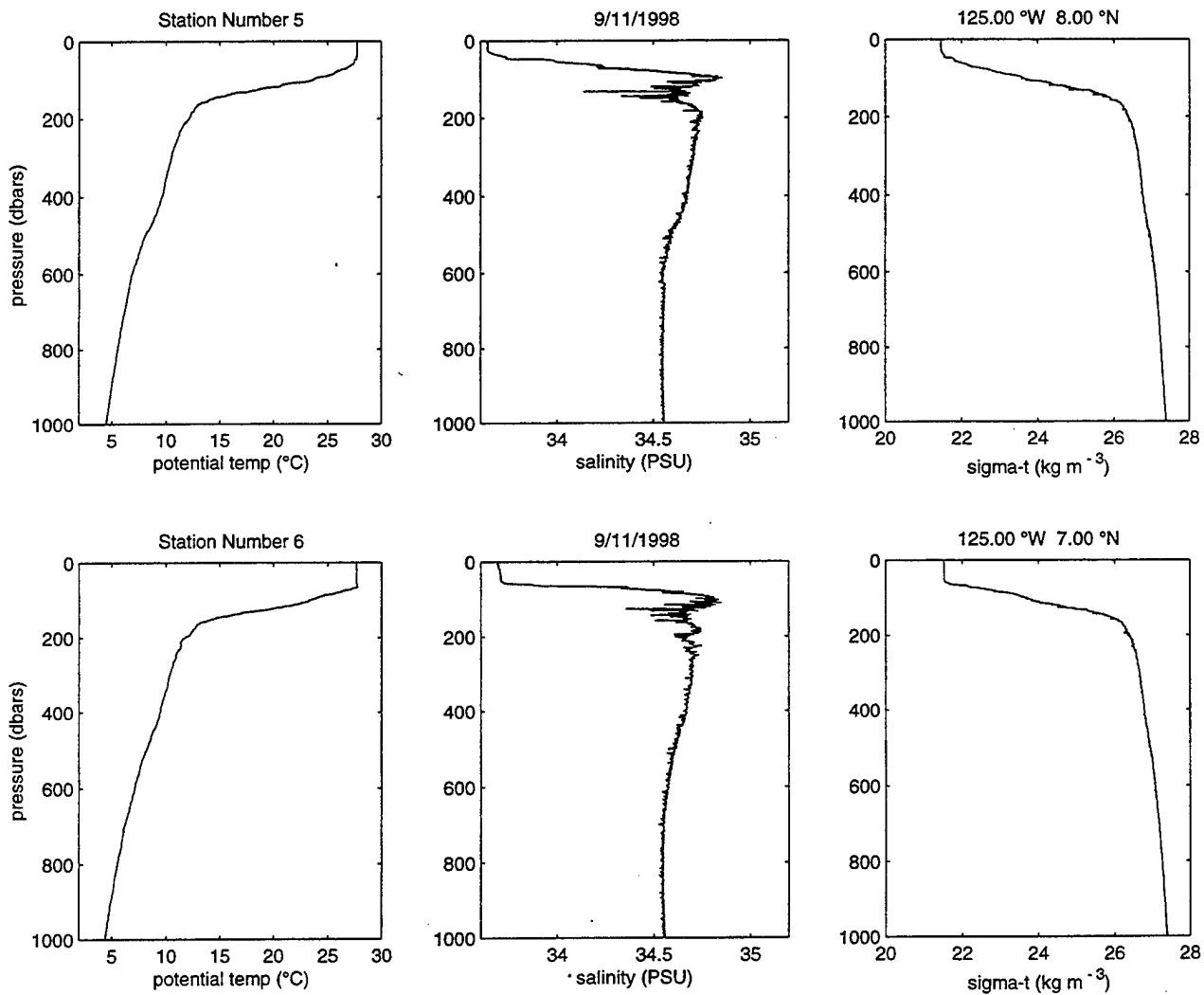

Figure A2-6: Profiles from CTD stations 7 and 8.

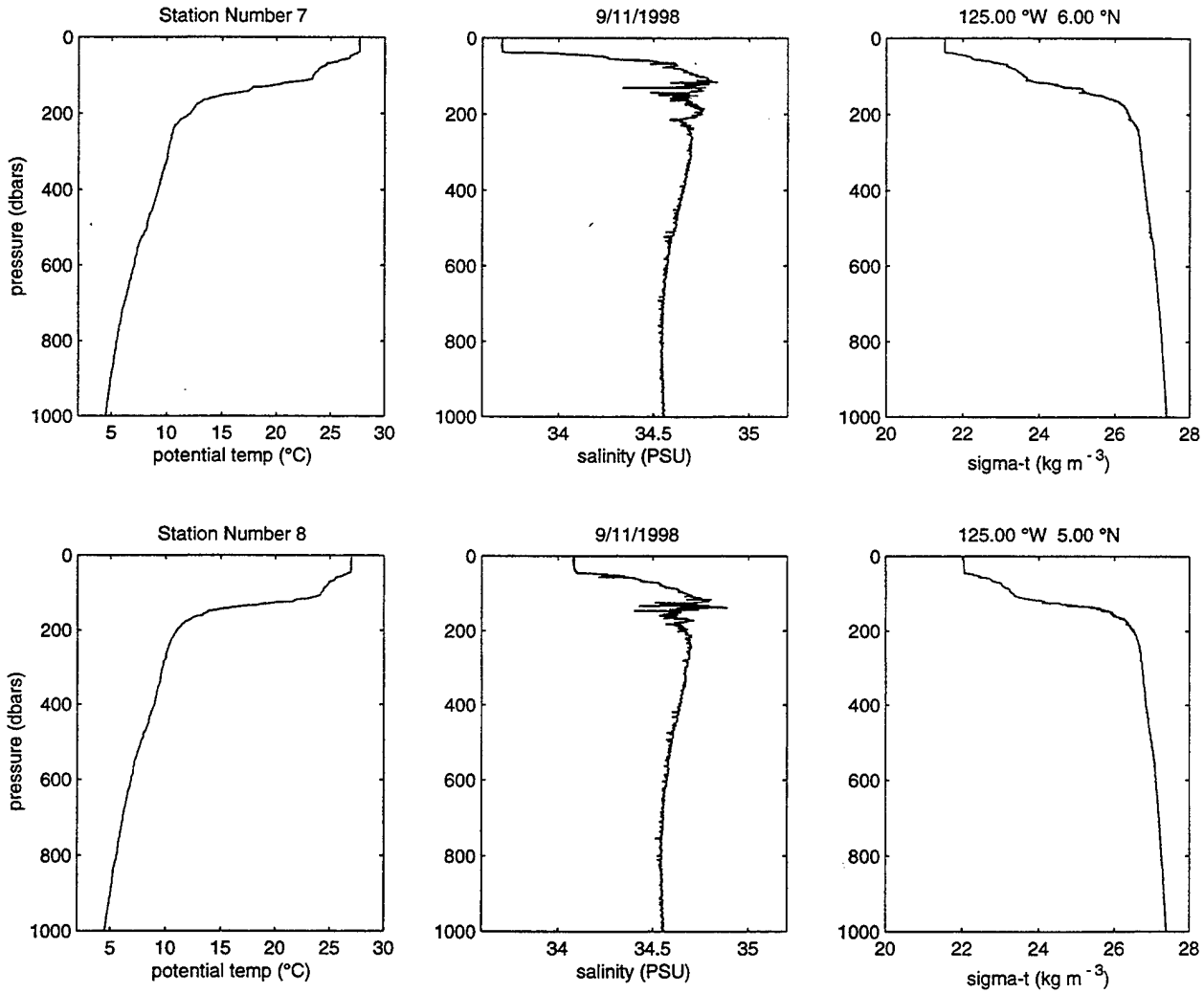

Figure A2-7: Profiles from CTD stations 9 and 10.

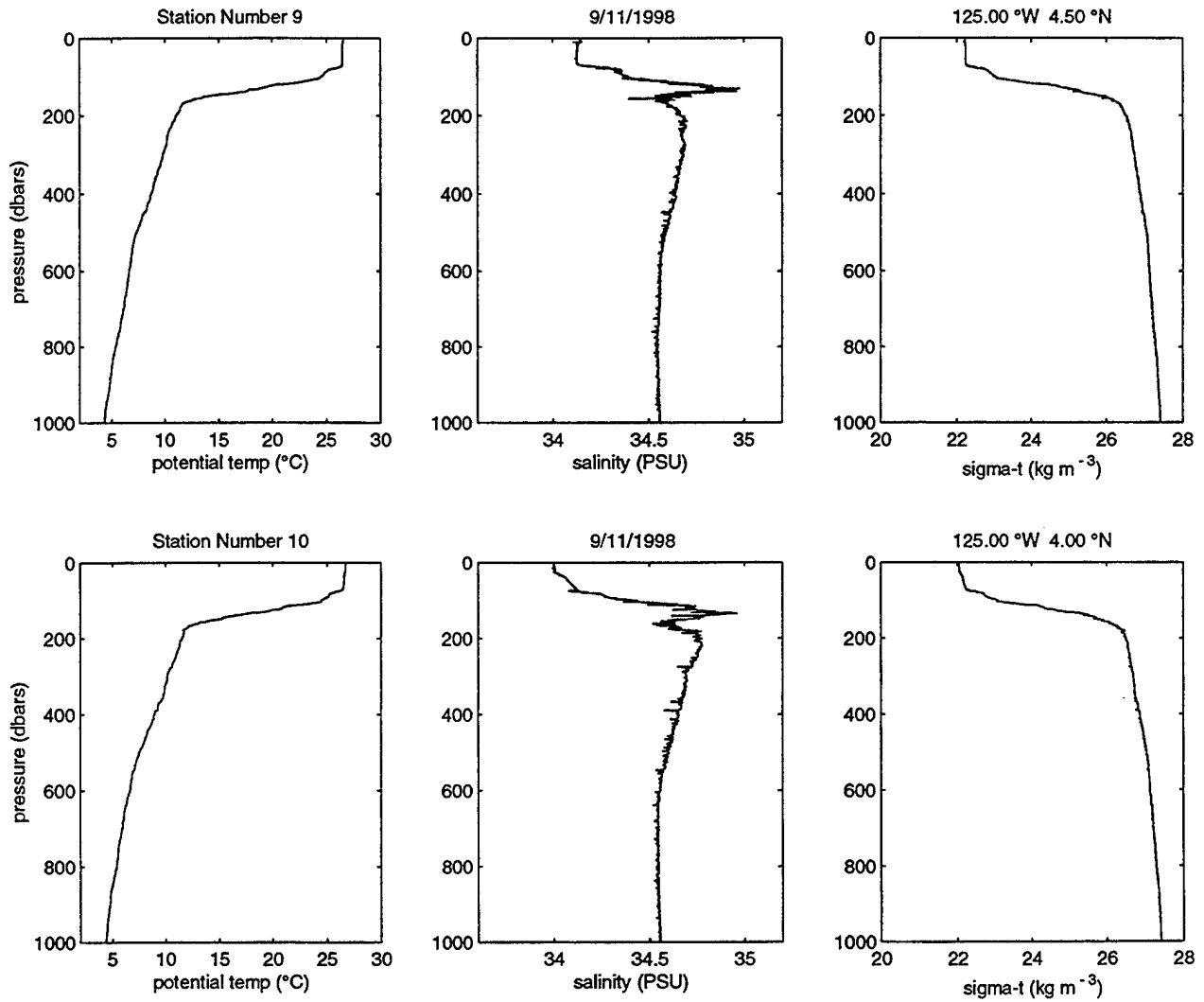

Figure A2-8: Profiles from CTD stations 11 and 12.

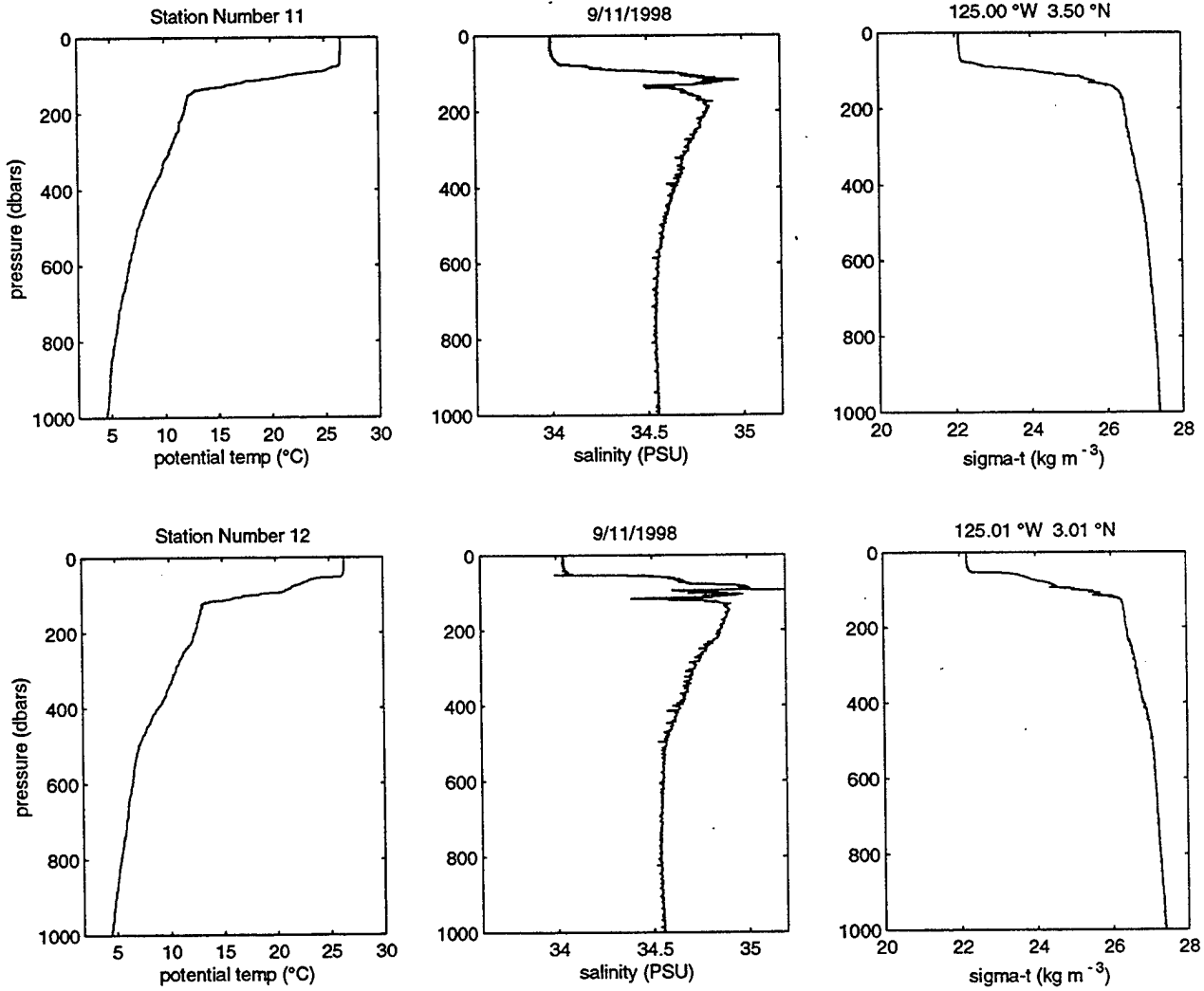

Figure A2-9: Profiles from CTD stations 13 and 14.

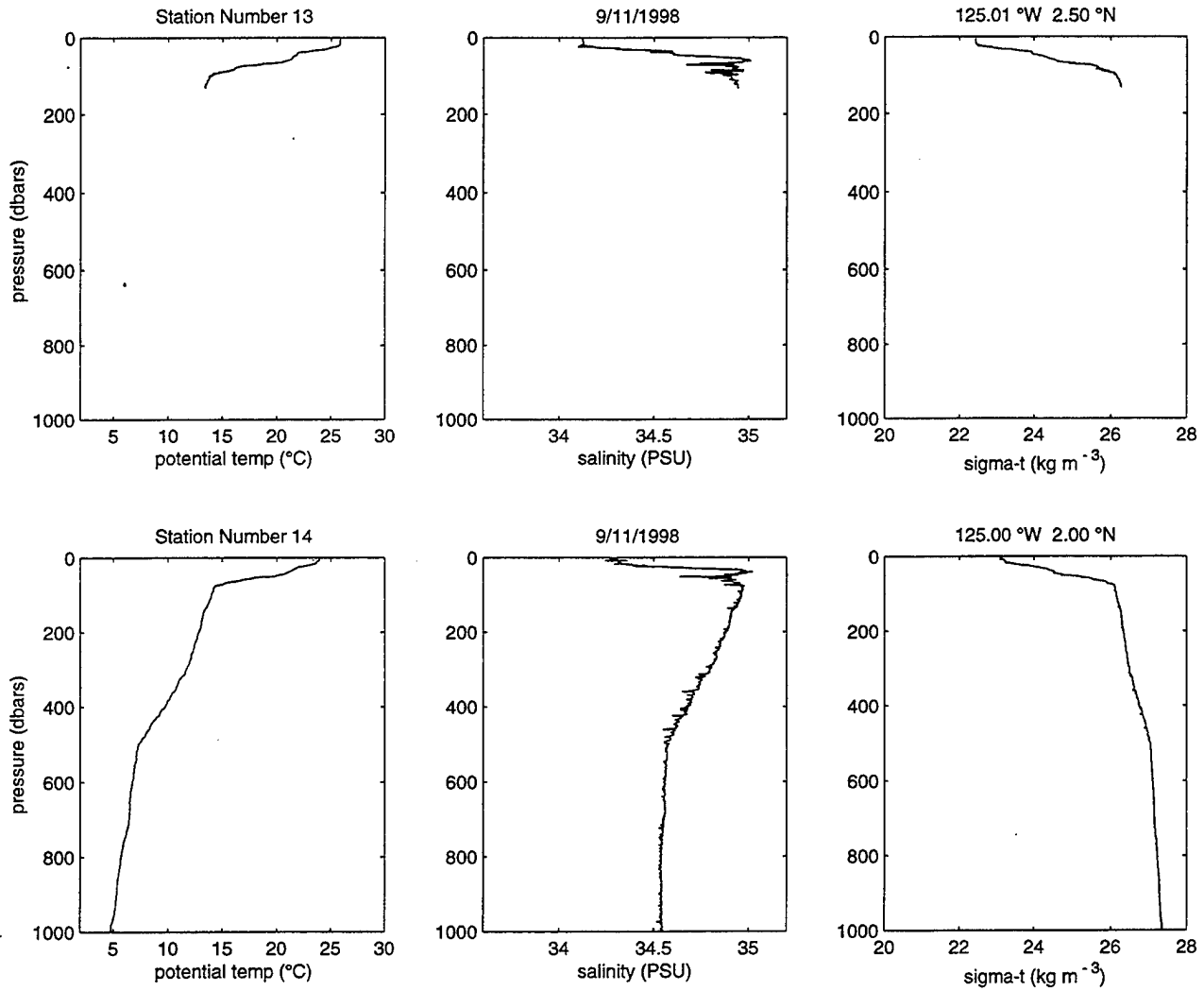

Figure A2-10: Profiles from CTD stations 15 and 16.

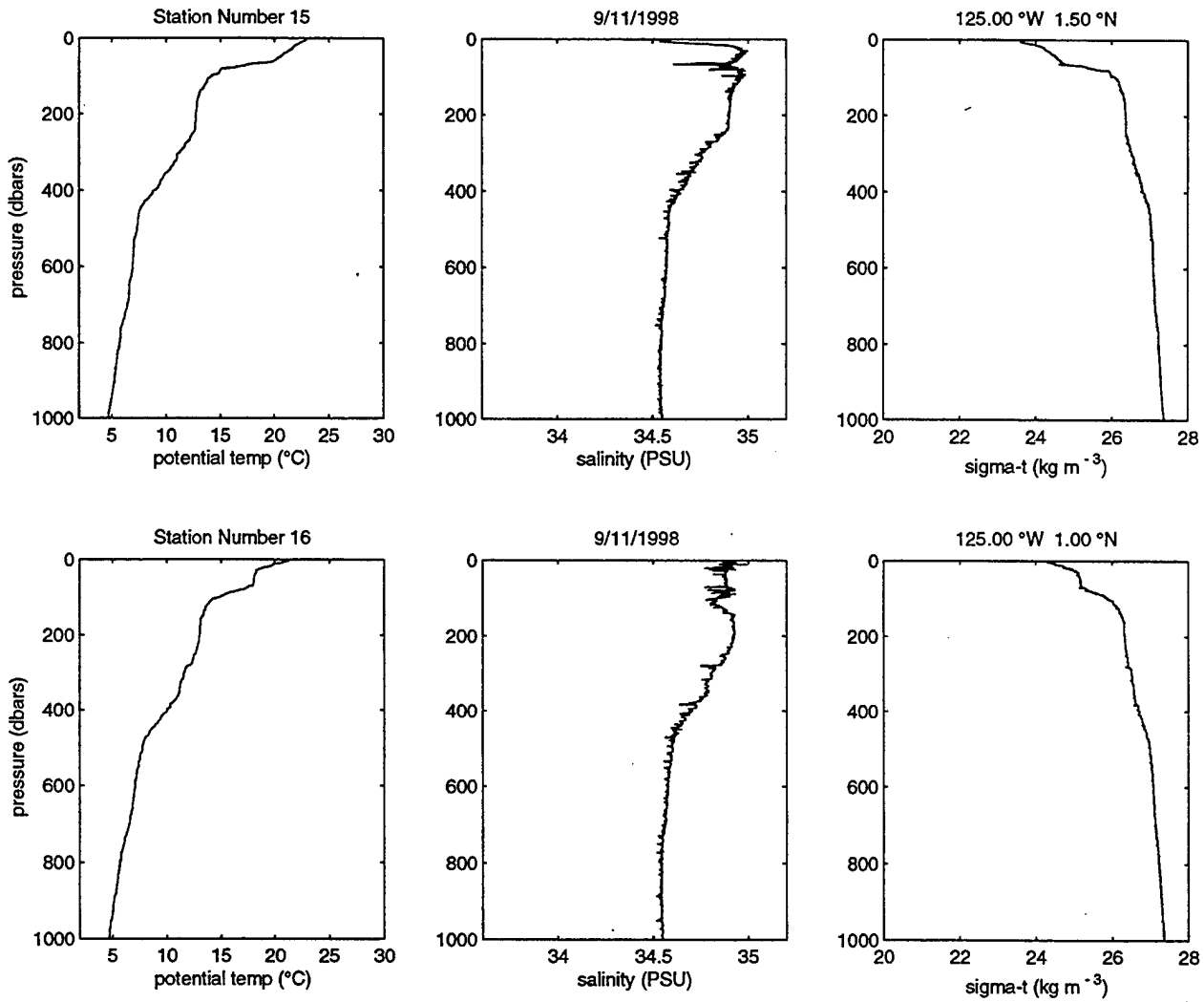

Figure A2-11: Profiles from CTD stations 17 and 18.

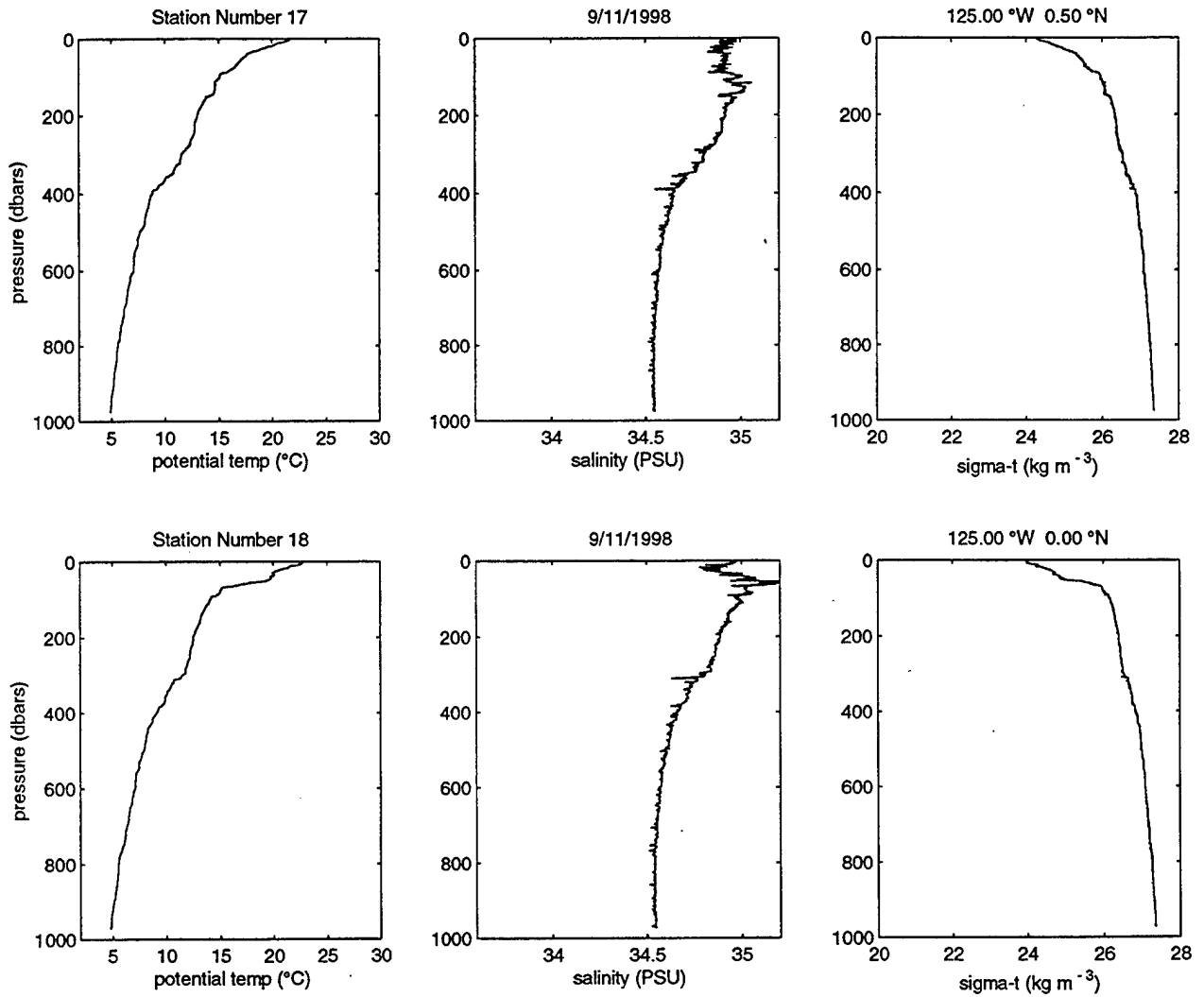

Figure A2-12: Profiles from CTD stations 19 and 20.

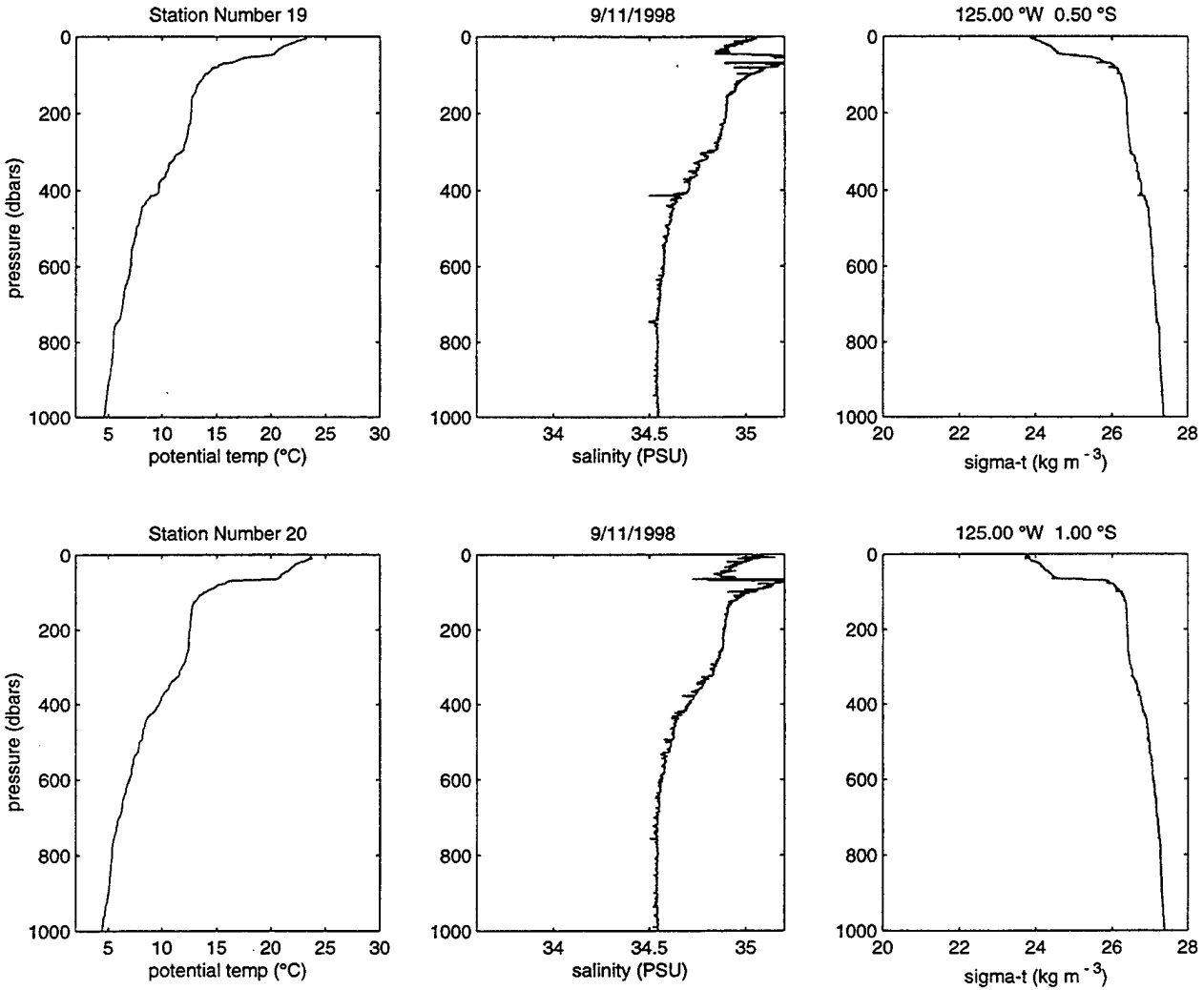

Figure A2-13: Profiles from CTD stations 21 and 22.

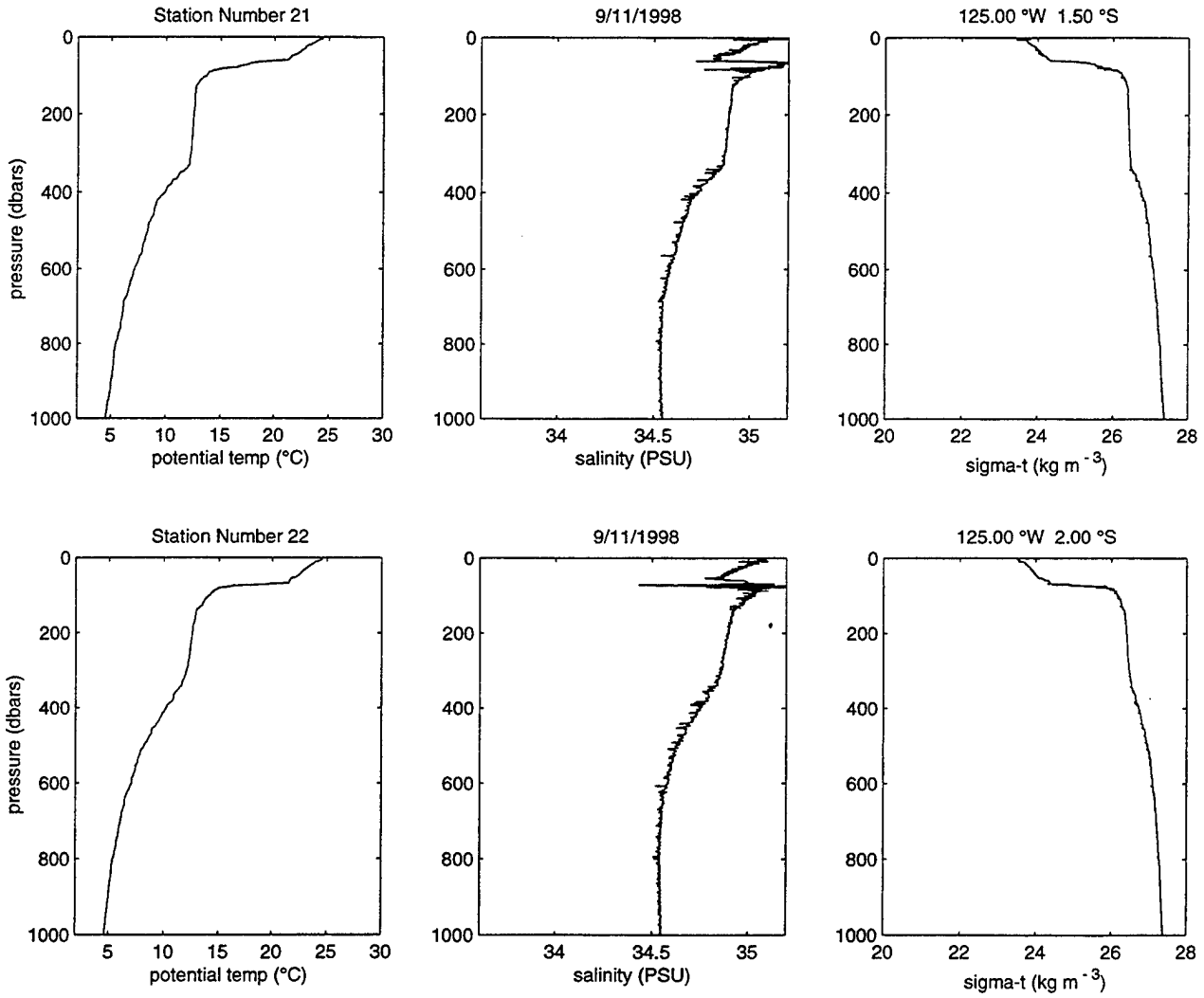
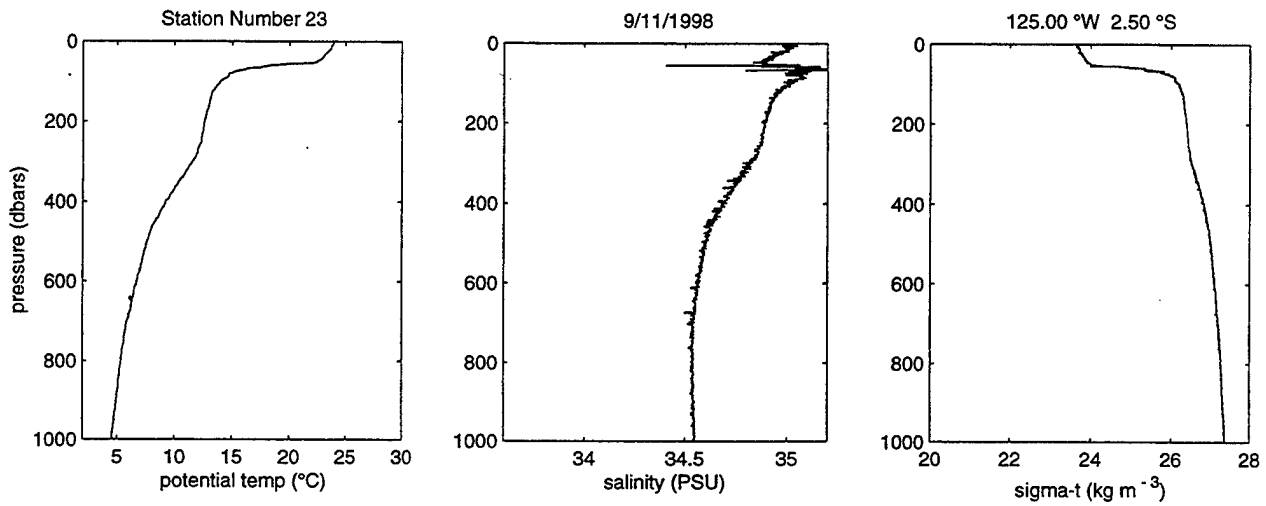

Figure A2-14: Profiles from CTD stations 23.



Appendix 3 Instrument Time Marks

Prior to and following the deployment of the moored instrumentation a time mark is put on the data record. In the case of the VMCMs this is done by rotor spins. The times of the rotor spins are recorded on the VMCM CMOI forms. The meteorological systems have a time mark applied to the data record by black bagging the short-wave radiation sensors and recording the time. The temperature recording instruments are placed in a cold bath and the time is recorded. The post-deployment time marks included here are for the PACS 2 South and North moorings.

Note: If there are any timing discrepancies for some of the above Branckers it may be due to their orientation in the cold bath. If a sensor was found out of the bath due to ship roll or a draining sink, the sensor was re-immersed. Time out of bath for all temperature loggers is accurate.

Time Mark
PACS Second Deployment
(PACS2)
19 Nov 97

Instrument	Time In UTC	Time Out UTC
Branckers		
2537	1820	1944
3508	1821	1943
4228	1821	1947
2535	1821	1944
3271	1821	1948
3291	1821	1948
3833	1821	1938
2533	1821	1944
3301	1821	1949
3296	1822	1948
3506	1822	1949
3702	1822	1949
3837	1822	1948
3274	1822	1947
3763	2104*	2227
4488	1822	1948
4402	1822	1940
3831	1823	1940
4486	1823	1939
2536	1823	1939
4493	2104*	2227
3308	1823	1939
3830	2104*	2227
2541	1823	1938
3834	1823	1939
3299	1823	1943
3507	1824	1949

MTR		
3241	1824	1909
4239	1824	1909
3246	1824	1909
3242	1824	1909
WaDaR		
62	1824	1909
272	1908	1937
273	1908	1937
SEACAT		
1882	1826	1904
1879	1829	1904
1878	1826	1904
146	1827	1907
1873	1827	1906
1874	1827	1902
1881	1828	1903
142	1828	1905
2322	1829	1905
141	1829	1906
927	1830	1902
1875	1830	1905
1876	1831	1901
1880	1831	1902
1877	1831	1903
MicroCAT		
008	1832	1907
011	1832	1907

* More than one cold spike may be present. Time represents the last one on that date.

Appendix 4

WHOI Instrumentation Deployed during PACS 1 and 2

Vector Measuring Current Meters

Instrument	Deployment	Mooring	Depth (in meters)
VM-001	PACS 2	WHOI North	110
VM-002	PACS 2	WHOI North	90
VM-009	PACS 1	WHOI South	5
VM-010	PACS 2	WHOI North	20
VM-011	PACS 1	WHOI South	10
VM-012	PACS 2	WHOI North	70
VM-013	PACS 1	WHOI North	40
VM-014	PACS 1	WHOI North	15
VM-015	PACS 1	WHOI North	20
VM-016	PACS 1	WHOI North	5
VM-017	PACS 2	WHOI North	5
VM-018	PACS 1	WHOI South	70
VM-019	PACS 1	WHOI North	110
VM-020	PACS 1	WHOI North	10
VM-021	PACS 1	WHOI South	110
VM-022	PACS 2	WHOI South	30
VM-023	PACS 2	WHOI South	10
VM-025	PACS 1	WHOI South	40
VM-026	PACS 1	WHOI North	90
VM-027	PACS 2	WHOI North	40
VM-028	PACS 2	WHOI North	30
VM-030	PACS 2	WHOI South	90
VM-031	PACS 1	WHOI North	70
VM-032	PACS 1	WHOI South	50
VM-033	PACS 1	WHOI North	50
VM-034	PACS 2	WHOI South	70
VM-037	PACS 1	WHOI North	30
VM-038	PACS 1	WHOI South	20
VM-039	PACS 1	WHOI South	30
VM-040	PACS 2	WHOI South	110
VM-041	PACS 2	WHOI South	15
VM-043	PACS 2	WHOI South	20
VM-044	PACS 2	WHOI North	10
VM-045	PACS 2	WHOI South	5
VM-051	PACS 2	WHOI South	40
VM-052	PACS 2	WHOI North	90
VM-053	PACS 2	WHOI South	50
VM-055	PACS 2	WHOI North	15
VM-056	PACS 1	WHOI South	15
VM-201	PACS 2	WHOI South	130

Brancker Temperature Recorders

Instrument	Deployment	Mooring	Depth (meters)
2533	PACS 2	WHOI South	50
2535	PACS 2	WHOI North	35
2536	PACS 2	WHOI South	200
2537	PACS 2	WHOI North	60

Brancker Temperature Recorders (continued)

Instrument	Deployment	Mooring	Depth (meters)
2541	PACS 2	WHOI North	45
3258	PACS 1	WHOI North	1.50
3259	PACS 1	WHOI North	7.50
3263	PACS 1	WHOI North	0.25
3265	PACS 1	WHOI South	7.50
3279	PACS 1	WHOI South	35.00
3283	PACS 1	WHOI South	100
3299	PACS 2	WHOI South	100
3301	PACS 2	WHOI South	35
3309	PACS 1	WHOI North	45
3506	PACS 2	WHOI South	22.5
3507	PACS 2	WHOI South	25
3508	PACS 2	WHOI North	22.5
3662	PACS 1	WHOI North	150
3667	PACS 1	WHOI South	60
3699	PACS 1	WHOI South	0.50
3701	PACS 1	WHOI South	1
3701	PACS 2	WHOI North	100
3702	PACS 2	WHOI South	60
3703	PACS 1	WHOI North	25
3704	PACS 1	WHOI North	2.50
3761	PACS 1	WHOI North	35
3762	PACS 1	WHOI South	200
3763	PACS 2	WHOI South	12.5
3764	PACS 1	WHOI South	2.50
3764	PACS 2	WHOI North	150
3831	PACS 2	WHOI South	45
3835	PACS 1	WHOI South	0.25
3835	PACS 2	WHOI North	200
3836	PACS 1	WHOI South	7.50
3838	PACS 1	WHOI North	2
3839	PACS 1	WHOI North	200
4481	PACS 1	WHOI North	17.50
4482	PACS 1	WHOI South	150
4483*	PACS 1	WHOI South	45
4485*	PACS 1	WHOI North	1
4487	PACS 1	WHOI North	100
4488	PACS 2	WHOI North	12.5
4489	PACS 1	WHOI South	2
4491	PACS 1	WHOI North	0.50
4492	PACS 1	WHOI South	1.50
4493	PACS 2	WHOI North	25
4494	PACS 1	WHOI South	25
4495	PACS 1	WHOI North	60

* Brancker temperature logger number 4483 appears in the mooring log for mooring number 1015 (PACS 1 WHOI North) as having been deployed on the near surface temperature string at 1.00 meters depth. Brancker number 4485 appears in the mooring log of mooring number 1014 (PACS 1 WHOI South) as having been deployed at 45 meters depth. When the data was read from these instruments it was observed that data from instrument 4483 was included in a backup file with data from mooring 1014; and similarly data from 4485 was included with data from mooring 1015. A look at the data indicates that instrument 4485 has temperature data representative of the near-surface environment and instrument 4483 has data representative of 45 meters depth. The conclusion drawn from this is that the instrument numbers on the pressure cases were either misread or mislabelled resulting in

the error in the mooring log. There is no confusion as to which data set belongs to which instrument since the data header automatically includes the instrument number. Therefore, it appears that instrument 4483 was deployed on mooring 1014 at 45 meters, and instrument 4485 was deployed on mooring 1015 at a nominal depth of 1.0 meters.

SEACAT temperature and conductivity recorders

Instrument	Deployment	Mooring	Depth (meters)
141	PACS 2	WHOI North	17.50
142	PACS 2	WHOI South	47.50
143	PACS 1	WHOI South	1.71
927	PACS 2	WHOI North	47.50
928	PACS 1	WHOI North	12.50
929	PACS 1	WHOI South	32.50
991	PACS 1	WHOI South	22.50
992	PACS 1	WHOI North	32.50
993	PACS 1	WHOI South	12.50
994	PACS 1	WHOI North	1.86
995*	PACS 1	WHOI North	22.50
1873	PACS 2	WHOI North	37.50
1874	PACS 2	WHOI South	7.50
1875	PACS 2	WHOI North	27.50
1876	PACS 2	WHOI South	37.50
1877	PACS 2	WHOI North	65
1878	PACS 2	WHOI South	17.50
1880	PACS 2	WHOI South	65
1881	PACS 2	WHOI North	7.50
1882	PACS 2	WHOI South	1.50
2322	PACS 2	WHOI North	1.50

* SEACAT 995 was lost at sea. Many of the PACS 1 North instruments were recovered with fish net entangled around them. The strength member that held instrument 995 was also recovered with fish net and it appears that the instrument may have been pulled from the strength member during attempts by a fishing vessel to free their nets.

MTRs

Instrument	Deployment	Mooring	Depth
3240	PACS 1	WHOI North	3.5
3241	PACS 2	WHOI North	3.5
3242	PACS 2	WHOI South	3.5
3243	PACS 1	WHOI South	3.5

WaDaR

Instrument	Deployment	Mooring	Depth
272	PACS 2	WHOI North	Surface
273	PACS 2	WHOI South	Surface
274	PACS 1	WHOI South	Surface
275	PACS 1	WHOI North	Surface

MicroCATs

<u>Instrument</u>	<u>Deployment</u>	<u>Mooring</u>	<u>Depth</u>
008	PACS 2	WHOI South	80
009	PACS 1	WHOI North	80
010	PACS 1	WHOI South	80
011	PACS 2	WHOI North	80

CHLAM

<u>Instrument</u>	<u>Deployment</u>	<u>Mooring</u>	<u>Depth</u>
ACH0126	PACS 1	WHOI South	27.5

FSI current meter

<u>Instrument</u>	<u>Deployment</u>	<u>Mooring</u>	<u>Depth</u>
1428A	PACS 1	WHOI South	130

SHERMAN current meter

<u>Instrument</u>	<u>Deployment</u>	<u>Mooring</u>	<u>Depth</u>
002	PACS 1	WHOI South	120
001	PACS 2	WHOI South	120

Acoustic rain gauge

<u>Instrument</u>	<u>Deployment</u>	<u>Mooring</u>	<u>Depth</u>
002	PACS 1	WHOI North	29

Bio-optical package

<u>Instrument</u>	<u>Deployment</u>	<u>Mooring</u>	<u>Depth</u>
000	PACS 2	WHOI South	27.5

Appendix 5

Wind Direction Sensor Comparison Tests

Part of the preparation of the meteorological packages includes checking the wind direction sensors. This consists of placing each buoy on a pallet that can be rotated through 360° and directing the wind vane to a fixed target at 60° intervals. The direction is then computed from the instrument compass and vane direction data. This procedure was followed both in Woods Hole prior to shipping and again in Hawaii on the dock prior to loading the buoys on the ship.

The test site in Woods Hole was located at the southern corner of the Clark South Laboratory parking area. This site showed little horizontal or vertical spatial variation in the magnetic field. The buoys were mounted, each in turn, on a large wooden pallet that could be rotated and the direction of a tree near the Clark building was measured from six buoy orientations. At each of the six positions the wind vane was aligned to the tree by eye and locked in position. The data were then read directly from the instrument. In the case of the VAWR, the compass and vane positions were added to obtain the wind vane direction in oceanographic convention (i.e., the wind direction of flow from the north is 180°.) The magnetic bearing to the tree from the test site was 309°.

A test site was chosen at the University of Hawaii Marine Center based on proximity to overhead wiring, steel shipping containers, and a brief survey of the area. By sighting on a distant light pole in clear view from several lateral positions, an area with small magnetic field gradients was identified. The direction checks conducted in Hawaii were intended to identify any gross problems that might have occurred in the instrumentation during shipping and should not be considered a calibration since careful site selection was not possible. The magnetic bearing to the distant object sited in Hawaii was 158°.

Figures A5-1 and A5-2 show the direction comparison tests that were conducted in Woods Hole. Figures A5-3 and A5-4 are the results of direction comparison tests conducted at the University of Hawaii Marine Center dock.

Figure A5-1: Wind direction comparison tests, PACS 2 North.

PACS 2 North Buoy Spin

24 September 1997

Woods Hole Oceanographic Institution

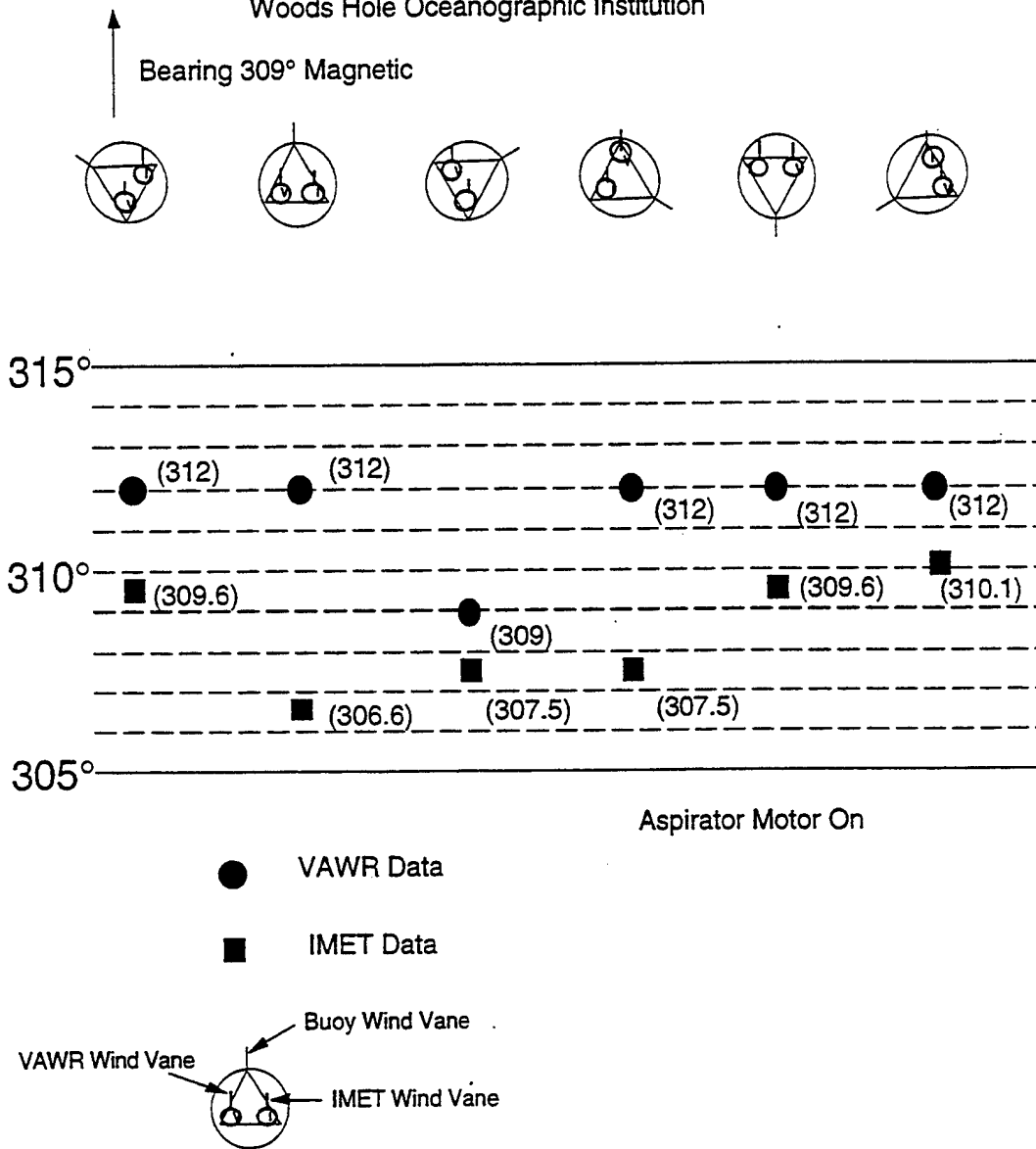

Figure A5-2: Wind direction comparison tests, PACS 2 South.

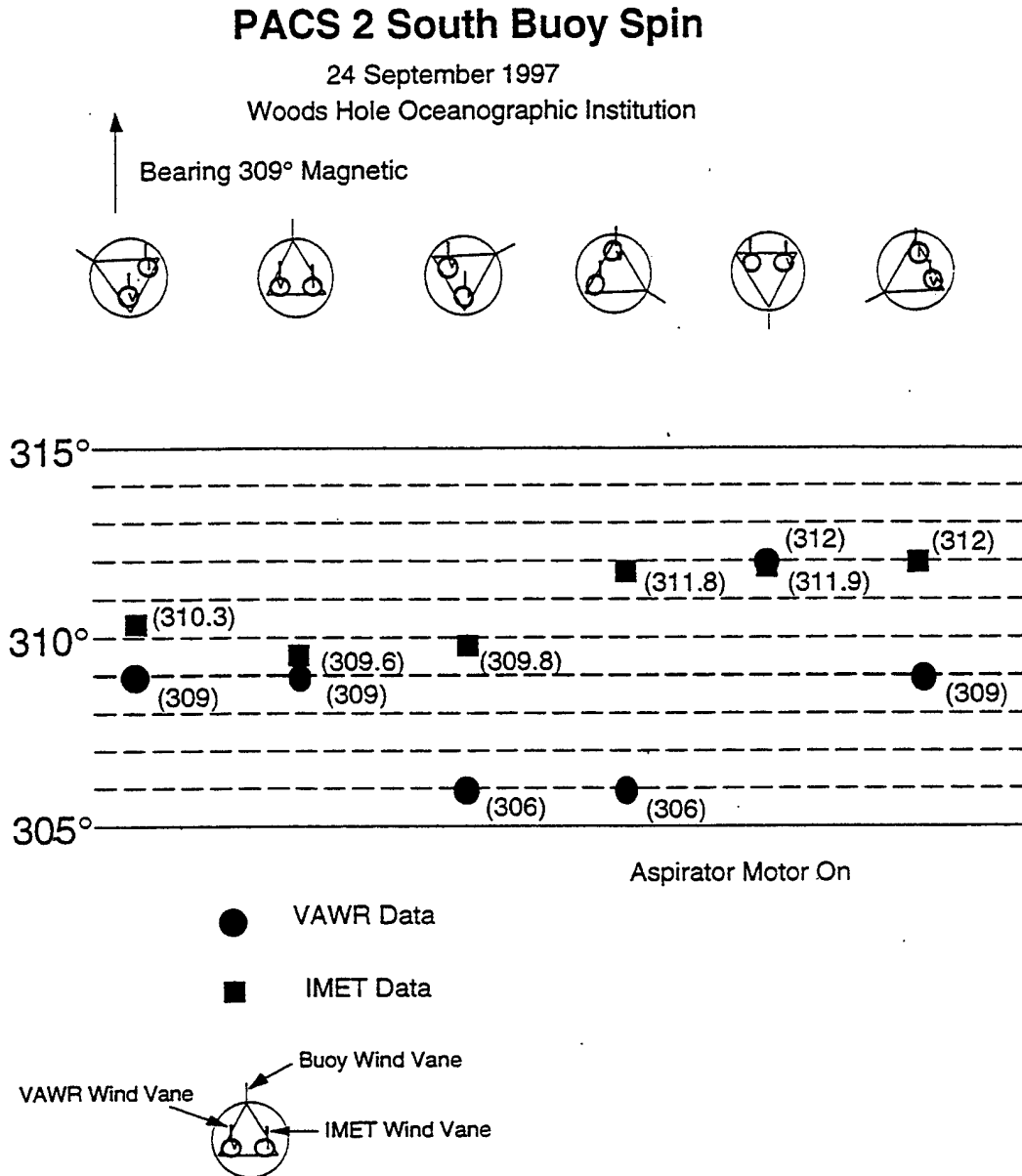

Figure A5- 3: Wind comparison tests (Hawaii), PACS 2 North.

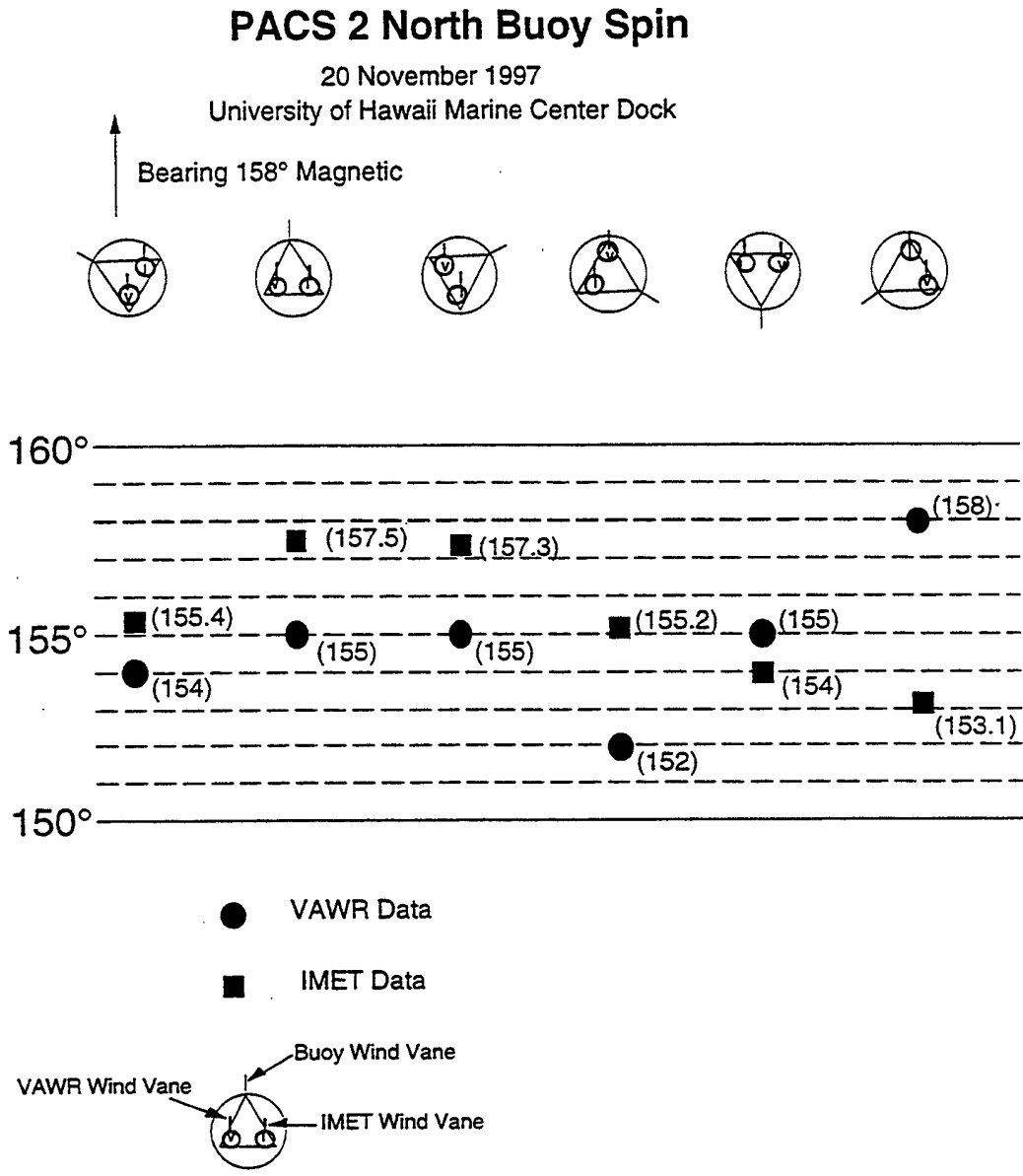
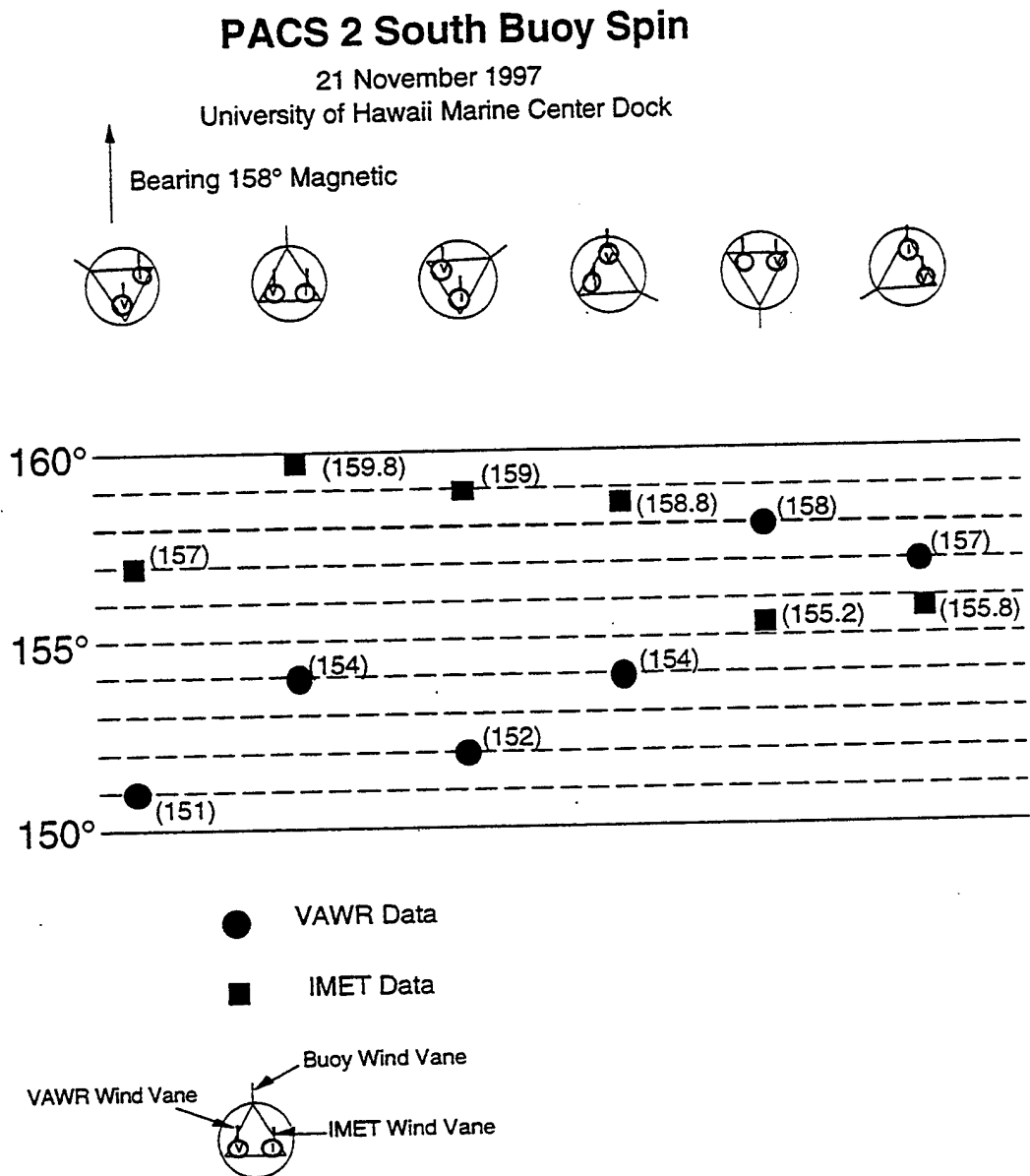

Figure A5- 4: Wind comparison tests (Hawaii), PACS 2 South.



Appendix 6 VMCM Record Format

1. RECORD COUNTER (TIME)

The first 16 bits (four characters) of data comprise the record number. The counter is incremented once each data record. The first record number is one (0001) and is used to initialize the instrument. The data and length of the first record may be invalid and should be ignored. Record two (0002) contains data for the first record interval. After 65535 records, the record counter will reset to zero and begin its normal counting.

2. NORTH VECTOR

Each vector is scaled from a 24-bit accumulator and stored in a 16-bit floating-point representation. This vector is the algebraic sum of the NORTH component of current flow from each sample.

3. EAST VECTOR

Each vector is scaled from a 24-bit accumulator and stored in a 16-bit floating-point representation. This vector is the algebraic sum of the EAST component of current flow from each sample.

4. ROTOR 2 (X CURRENT FLOW) (UPPER)

The rotor counts are an algebraic sum of the counts for a record interval. Rotor counts are scaled from a 24-bit accumulator and stored as a 16-bit floating number.

5. ROTOR 1 (Y CURRENT FLOW) (LOWER)

The rotor counts are an algebraic sum of the counts for a record interval. Rotor counts are scaled from a 24-bit accumulator and stored as a 16-bit floating number.

6. COMPASS

The compass field is an 8 bit 2's complement number (-128 to +128 decimal). The stored value is measured at the beginning of the last sample of the record interval.

7. TEMPERATURE

One temperature sample is taken at the beginning of each record interval.

Record interval = 2 seconds to 2 hours

Sample interval = .25 seconds to 2 seconds in quarter second steps

PREAMBLE/	TIME/	NORTH/	EAST/	R2/	R1/	COMPASS/	TEMP./	PARITY
(2)	(4)	(4)	(4)	(4)	(4)	(2)	(4)	(1)

(X) = Number of characters

Appendix 7

Mooring Recovery Operations

The PACS North and South surface moorings recovered from the *Melville* used the UOP reverse haul technique. This technique allows heavily instrumented surface moorings to be recovered in a safe and orderly fashion that optimizes available deck space.

The mooring gear used in the recovery of the surface moorings included: the TSE mooring winch, stern A-frame, ship's capstan, 01-deck crane; and the standard complement of chain grabs, Engersal air tuggers, stopper lines. Figure A7-1 shows the location of various pieces of deck equipment utilized during mooring operations on PACS03MV

The R/V *Melville* was positioned 1 mile down wind from the moored discus buoy. The acoustic release was fired and the bottom glass ball flotation attached to the bottom of the mooring was allowed to reach the surface. The TSE winch's drum tag line reeved through a large throated trawl block hung in the ship's A-frame which had been passed around out board along the starboard rail to aft of the rag top container. Two throwing grappels and a WHOI developed removable pickup pennant and hook were rigged and positioned aft of the container. The pickup pennant was rigged in the following manner with a 6 foot Liftall sling with a load rating of 6000 lbs. was bent through the free end of pickup pennant in a barrel hitch and secured to the pickup pennant with marlin line. It was discovered that the length of the pick up pole and pennant was 13 feet, and the vertical height from the rail to the sea surface was approximately the same, making it very difficult to insert the shackle attached to the TSE tag line onto the soft eye end of the pickup pennant; once the pickup hook had been hooked onto the glass balls and the pennant took up the tension of the glassballs. A 40 foot x 3/4 inch nylon tag line was tied to the soft eye of the pennant. Once the glassball cluster had come to the surface, the ship slowly steamed up wind with the weather on the starboard side towards the back up flotation. As the glass ball cluster drifted along the side of the ship, the two grapples were thrown hooking into the chain on which the glassballs were attached. Following the hooking up of the pickup pennant to the glassball the TSE tag line was shackled onto the Liftall sling. With the A-frame positioned out board, the ship steamed slowly forward to allow the glassballs to drift aft of the ship. The 40 foot tag line and the TSE tag line were slipped aft with the glass balls and cast once the ball cluster had passed aft of the ship. The TSE tag line was wound up pulling the glassballs up to the stern of the ship. The A-frame was repositioned inboard so that the glass balls could be lifted just outboard of the ship's transom. Approximately 30 percent of the ball cluster was lifted up 8 to 10 feet above deck level. A bull rope running from the capstan along with 2 air tuggers was hooked into excessable chain segments in the hanging ball cluster. The A-frame was brought inboard as the TSE winch haled in the tag line in order to prevent the hanging balls from going back over the stern. The two tuggers and capstan lines hauled in as the winch and A-frame shifted together. The remaining hanging glass below deck level was pulled up onto the fantail. The tugger winches and capstan lines are stopped and secured. The acoustic release and the 1 1/8" polypropylene line, in most cases, are the remaining mooring components hanging over the ship's transom at this point of the recovery. The acoustic release was stopped off to a deck cleat and disconnected from the glass ball cluster. The polypropylene mooring line was stopped off at the termination point between the glassballs, and the 1/2 inch chain shot shackled to the acoustic release to another cleat using a stopper line. The TSE tag line was lowered and disconnected. The A-frame was brought outboard and so that the winch tag line hung just clear of the transom. The shackle from the tag line was then secured to the stopped off chain and acoustic release. The winch tag line was hauled up taking the tension of the hanging instrument and the stopper was eased off and removed. The release was lifted up clear of the deck and the A-frame swung

Figure A7-1: Deck layout to PACS 2 North and South Recovery

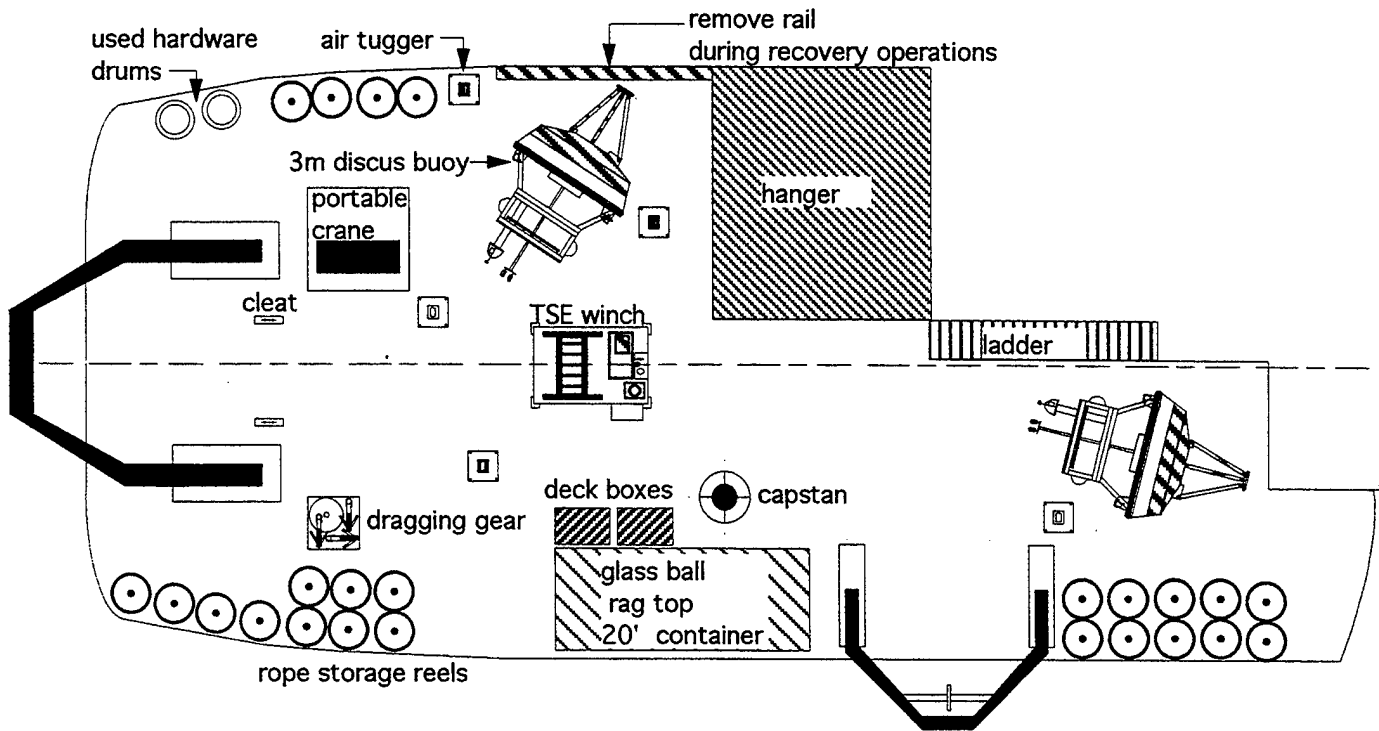

inboard. The winch tag line paid out the tag line lowering the release to the deck. The release was carried to the instrument staging area forward along the starboard side. The tag line was shackled to the stopped off to the polypropylene's end link. The same process of transferring the mooring tension between the deck stopper and the winch tag line was repeated to connect the polypropylene line to the TSE tag line. With the winch line shackled to the mooring line approximately 10 to 12 feet of polypropylene line was hauled in. The steel thimble used in the splice to terminate the end of the polypropylene line was too large to pass through the throat of the trawl block. It was necessary to stop off the mooring line using a 3/4 inch nylon tag line using a timber hitch knot. The location of the knot was tied approximately 10 to 12 feet away from the thimble end of the polypropylene line. This tag line was secured to a deck cleat and the winch slowly paid out easing the mooring tension to the tag line. The winch tag line was unshackled from the mooring line and the thimble eye splice of the polypropylene cut off. A bowline knot was tied from the loose end of the mooring line and the winch tag line shackled to it. The winch tag line took on the mooring tension as the timber hitched tag line was eased off. The A-frame was shifted to its maximum outboard position to increase the fleet angle running from the winch fair lead to the A-frame block. The winch proceeded to haul in the polypropylene line as the ship steamed at approximately .5 knots ahead. The mooring crew for the next hour proceeded to untangle and unshackle the glass ball cluster so that the balls could be stored in the rag top container. The mooring recovery operation was stopped twice during the recovery to off spool the polypropylene and nylon into wire baskets and wooden AR34 reels respectively. As the mooring was being hauled in through the A-frame subsurface instrumentation was recovered using the same technique used to recover the acoustic release.

Following the recovery of the 40 meter VMCM, the mooring was cast adrift using a slip line. The remainder of the subsurface instrumentation and discus buoy was recovered along the port side using the 01 crane. Depending on sea swell conditions, mooring scope of less than 40 meters increases the potential of the mooring wire to snap load, possibly causing damage to subsurface instrumentation or capsizing the discus buoy. The ship's small boat was deployed to hook on the lifting pennant. The lifting pennant for the discus lift was rigged in the same way as the glassball lift. The small boat maneuvered along side the discus buoy and the pickup pole handler attached the pennant to the main lifting bail, (Figure A7-2) located on the discus deck. The ship backed slowly towards the small boat and discus buoy. A heaving line was cast from the ship to the small boat. The free end of the tag line was tied to the heaving line and cast off from the small boat. As the ship backed down on the discus buoy, the heaving line and tag line were brought over the port deck edge up to the crane hook. The crane was positioned so that the crane whip had 35 feet of vertical lift and tended slightly outboard over the side of the ship. The Liftall sling was hooked onto the crane hook and the crane swung outboard 4 of 5 feet. The crane whip lifted the discus buoy up to a parallel to the deck edge. The crane swung inboard to bring the hull against the side of the ship's hull. Three air tuggers hauling lines were attached to the discus buoy. The position of the tugger winches is detailed in the deck layout in Figure A7-1. The placement of the tugger hauling lines is critical to controlling the motion of the discus buoy as it is being lifted up clear of the deck and swung inboard. The tugger lines were attached to the discus at the following locations on the discus. Tugger #1 was first hooked to an upper tower bail. Tugger #2 and #3 were secured to the closest accessible tower bail tending aft and the apex of the discus bridle. Tugger lines #1 and #3 pulled opposing each other, with #3 secured at the apex of bridle acting as the pivot point. Tugger #2 checked the discus as the crane rotated inboard. With the three tugger lines in place the crane lifted the discus up so that the end of the discus bridle was 1 foot clear of the deck. A 1 inch Sampson bull rope fitted with a 3/4 inch chain grab reeved around the capstan was hooked onto the middle of the first 4 meter shot of 3/4" inch chain shackled to the discus tension cell clevis. The discus buoy was swung inboard as the # 1 and 2 tugger lines paid out and hauled in allowing the buoy hull to pivot on the #3 tugger line across the deck. Tension was taken up

Figure A7-2: Discus Bail Configuration

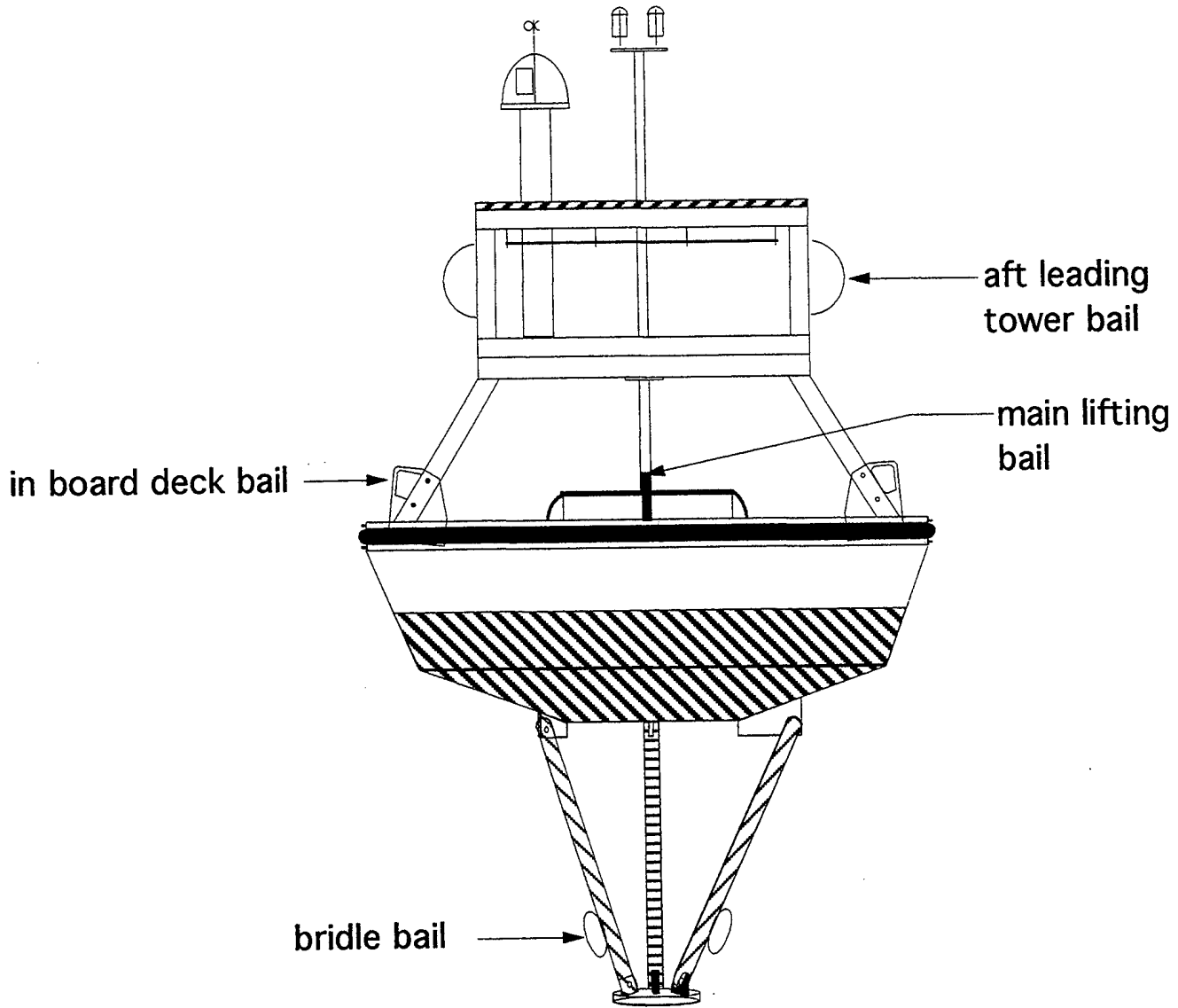

on the bull rope as the discus buoy was being lowered onto the deck, taking the hanging mooring tension off the discus buoy. The tugger lines were brought up tight and the two large wooden shoring wedges were placed against the hull and the deck. The capstan line was hauled in to cause the first shackle attached to the discus bridle to go slack. This shackle was disconnected. The discus buoy was then secured to the deck. The crane whip was unhooked from the discus and repositioned with maximum boom extension over the remaining stopped off mooring hanging over the deck edge. A 3/4 inch chain grab barrel hitched to a 6 foot Liftall sling was hooked on the stopped off 3/4 inch chain and hooked onto the crane hook. The crane was instructed to go up with the whip and as the tension went to the crane's whip, the capstan line was paid out and removed. The crane whip lifted up several instruments in manageable segments. The mooring string was stopped off again using the capstan line. The crane whip then lowered the instrumentation onto the deck to be disconnected and carried to the instrument staging area. This process was repeated until the remaining mooring component had been recovered. .

Miscellaneous Notes

During the disassembly and cleaning of the subsurface instrumentation and mooring hardware from 40 meters depth to the discus buoy it was noted that several of the 3/4" chain shackles that were directly shackled to the end bails of VMCM load cages had what appeared to have localized galvanic pitting around the middle of the steel shackle pin. The shoulder bushings used to isolate the stainless steel load cage bail from the steel shackle pin had approximately .125 separation between each bushing. It is speculated that rust deposits from the shackle pin may have collected in the gap between the bushings causing the stainless steel to come into direct contact with the steel pin. The redesign of the bushing, using two washers and a sleeve would provide 100% isolation between the shackle pin and the stainless bail.

The 1 inch bolt and nuts that were used to attach the bridle legs to the buoy and spider were severely corroded. The cotter pin holes enlarged from wear and the cotter pins rotated freely. None of the 1 inch nuts had backed off. The use of a second nut to lock the first and do away with the stainless steel cotter pin or change the material of the cotter pin to steel would reduce the galvanic corrosion and a potential failure.

Appendix 8 PACS 2 Antifouling Coating Test Results

The PACS North and South discus hulls for the second deployment were used as platforms to evaluate four antifouling paints, in the second of two tests to evaluate paints suitable for moored aluminum buoy hulls that are easy to apply, prevent the growth of Lepas gooseneck barnacles and are not federally or state regulated in application or use. The paints tested were Interlux, Micron-33, E Paint Co., No Foul SN-1; Reltek, Bondit B-2 and two samples from Magellan Companies Inc., BIO and CAP.

Micron-33 is a Tribyutal tin based ablative. The No Foul SN-1 is a vinyl copolymer ablative that reacts with ultraviolet sunlight to produce hydrogen peroxide as a by product. The hydrogen peroxide, in conjunction with an added organic algaecide acts as the deterrent. Bondit B-2 is a nontoxic, aethylene polymer that is reported to have good bonding and anti-fouling characteristics, as well as a longer service life compared to other bottom paints. The MAG-BIO and the MAG-CAP are proprietary phytochemical formulas from Magellan Companies, Inc. Table A8-1 details the samples wet film thickness, color and date of application.

Table A8-1: Antifouling coatings tested, PACS 2

Test Platform: PACS 2 North and South Discus Buoys
 Substrate: Aluminum Hull with top coat of instant set polyurethane elastomer.
 Type of Exposure: Waterline to 1 meter depth.
 Exposure: 9 months (December 97 to September 98)

<u>Sample</u>	<u>Color</u>	<u>Wet mil. Thickness and Application Date</u>
No Foul SN-1	White	8 mils. 10/97 plus 4 mils 12/97
Micron-33	Blue	8 mils 10/97 plus 4 mils 12/97
Bondit B-2	Clear	3 mils 10/97
MAG-CAP	Gray	10 mils 12/97
MAG-BIO	Gray	10 mils 12/97

The solar-shielded Brancker temperature recorders were well protected with the combination of No Foul SN-1 and Interlux Yacht Classic 2837, with the exception of the nylon spacers that separated the 13 plates of each assembly. The VMCM propellers, instrument stings and cages had barnacles growing on areas where the coating had either ablated away or where there was insufficient paint coverage. Potential instrument fouling for the two moorings was approximately 100-meter deep to the surface.

Figure A8-1 and Figure A8-2 illustrates the painting scheme used for each discus hull. The No Foul SN-1 and Micron-33 test areas were painted on the discus hulls so that they would be subjected evenly to the current flow around the discus hull while the buoy was moored. The Bondit B-2 and Magellan coatings were applied to several test areas positioned around discus hull chine. The control areas for this test were two 3 inch wide stripes which separated the No Foul SN-1 and Micron-33. Half the 12 inch x 12 inch test areas for the Bondit B-2 and Magellan coatings were left unprotected to act as the control. A high solids epoxy, Ameron PSX 700 was used as the paint for the control surfaces.

Figure A8-1: Antifouling paint test locations, PACS 2 North buoy hull.

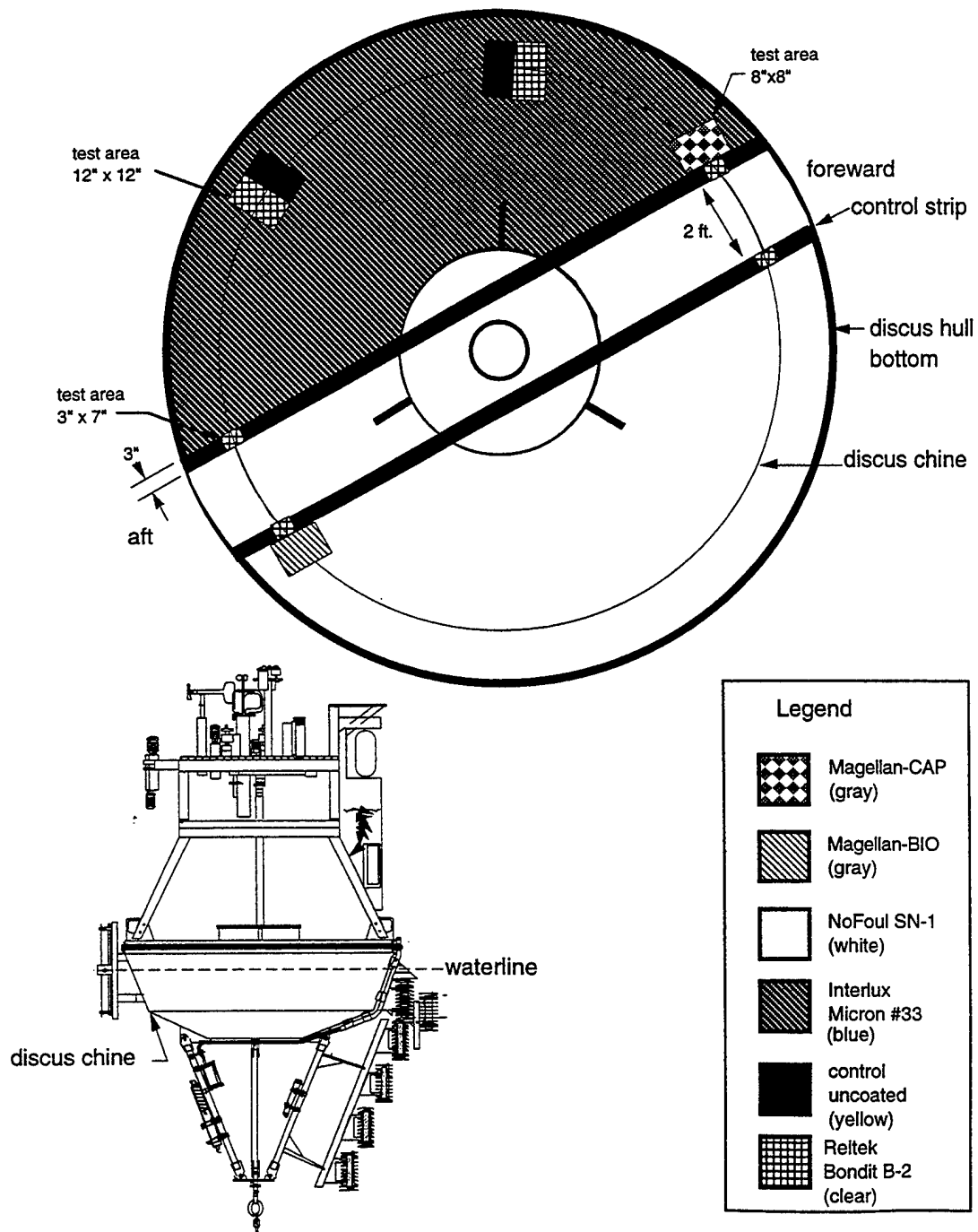
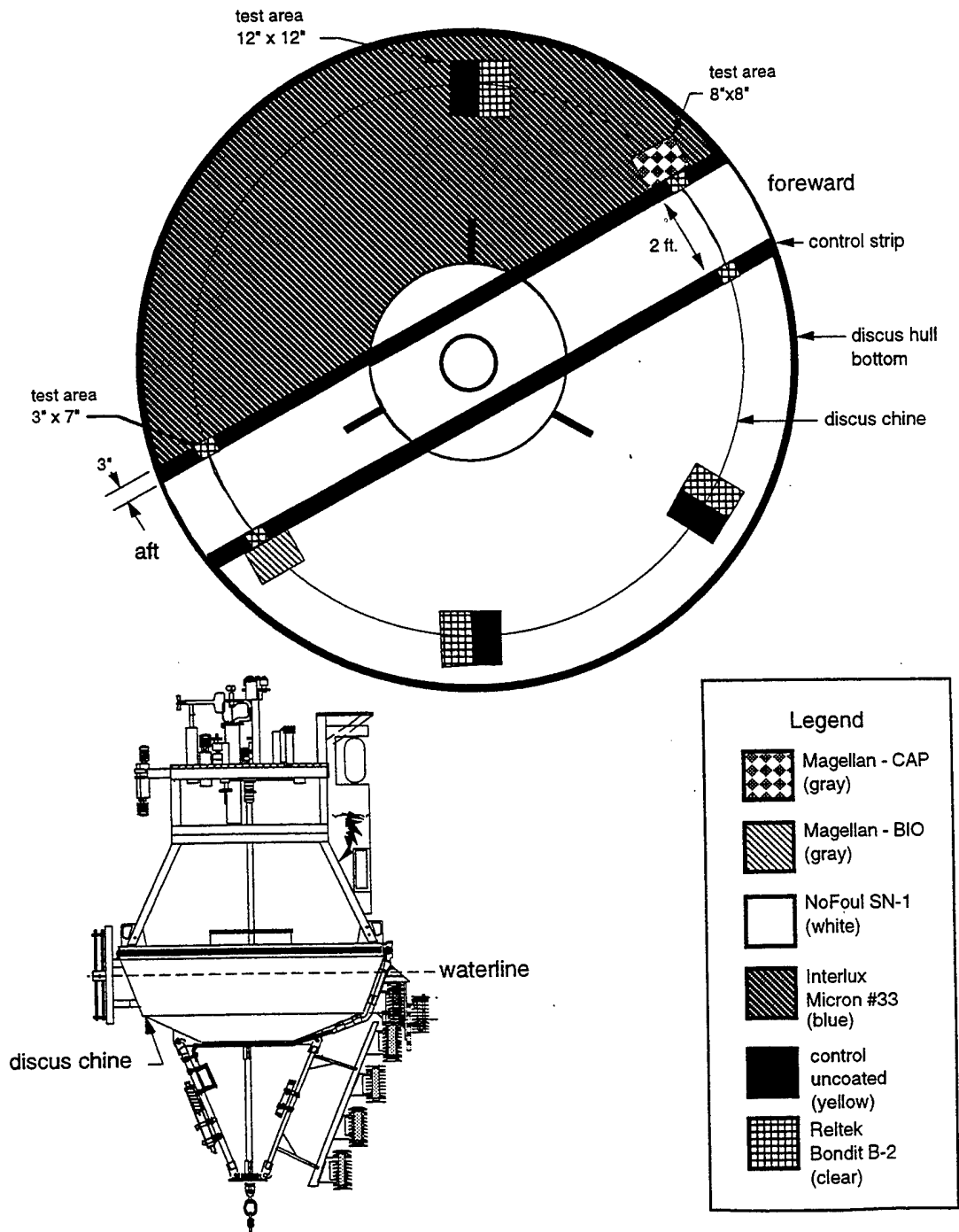

Figure A8-2: Antifouling paint test locations, PACS 2 South buoy hull.



Upon recovery of the two PACS 2 discus moorings, it was very obvious that the ocean environment for both was conducive for prolific gooseneck barnacle fouling. The control strip which separated the Micron-33 and No Foul SN-1 on both discus hulls had colonies of *Lepas* gooseneck barnacles which had grown to a length of 3 inches. The PACS 1 North and South discus had approximately 100% of the unprotected control strip fouled with barnacles.

The No Foul SN-1 and Micron-33 performed equally well. The North hull had a few barnacles attached to each of these test coating surfaces. The South hull had no barnacles fouling on the No Foul SN-1 and Micron-33 had a few barnacles attached to the hull test area. These paints had a thin brown algae film covering the tested surface. Upon recovery there was very little No Foul SN-1 and Micron-33 remaining on the either hull. It was evident that these coatings were near the end of their service life. The residual No Foul SN-1 was removed easily from the hull with a high-pressure washer. The remaining Micron-33 did not ablate away during the same process.

The North and South discus bridles were painted with No Foul-SN1. They had minimal fouling with the exception of the non-antifouling painted subsurface instrumentation which were 100% fouled with barnacles. The *Lepas* gooseneck barnacle preferred to attach as well to materials that were plastic, such as tie wraps and electrical tape.

The steel spider which joins the three bridle legs together was not painted or antifouled. Bolted to the spider was a stainless steel tension cell and universal joint by which the mooring was attached. The unpainted spider was used as an anode against the cathode tension cell. There was no fouling present on either spider. Prolific barnacle fouling was present on the tension cells and universal joints. Both steel spider showed evidence of electrolysis.

The Bondit B-2, MAG-CAP and MAG-BIO tested on the North discus was inconclusive because the control side of each of test squares had little no barnacle fouling. The test areas for these coatings on the South discus hull presented better results. The Bondit B-2 had varying amount and type of fouling on the coated side of the three 12 inch x 12 inch test areas located along the discus chine. The fouling present on the Bondit B-2 side of the test areas were; brown algae fouling, brown algae fouling with 3 barnacles and brown algae fouling with 14 barnacles. The control side of these test areas were heavily fouled with barnacles and brown algae. Three of the four 3 inch x 7 inch test areas, painted with Bondit B-2 showed good fouling protection with large barnacle colonies growing on the adjacent unprotected half of the test area. All the four test areas performed poorly in prevention of brown algae.

The MAG-CAP test patch had no barnacles attached to the test surface. There was a brown algae film covering the remaining coating and there were several barnacles found on the control stripe adjacent to this test sample. Following the recovery, the MAG-CAP was found to have delaminated from the substrate, and half of the coating had chipped off the discus hull. The remaining MAG-CAP was found to be very brittle and could be easily removed from the discus hull. The poor adhesion could possibly be due to the incorrect application. MAG-BIO coating did not have any barnacles growing on its test area located on the front edge of the buoy, as there was no visible coating remaining on the test area. The general condition of the the antifouling coating on the hull showed that the front or upwind side of the discus was the cleaner with less remaining paint then the center of the bottom moving toward the rear or downwind side of the discus.

The Brancker temperature recorder pipe on the South discus had many barnacles growing on the five Brancker temperature recorders and the nylon spacer that separated the

13 solar shields for each assembly. The solar shield had only a few barnacles. The solar shields were spray painted with No Foul SN-1 ashore and shortly before deployment the assembled Brancker and solar shields were spray painted with a Tribyutal tin based anti-foulant Interlux Trilux 2. The mass fouling on the instruments and nylon spacer could be due from inadequate anitfouling paint mil thickness or incompatibility of the paint to the nylon spacers as was seen with the tie wraps that were used to secure subsurface cabling. The North Brancker pipe was recovered to find that only the two upper instruments remained. The fouling present was similar to the South Brancker pipe.

The WaDaR sea surface temperature recorder and bracket for the North and South moorings had only a few barnacles attached to the top and bottom of the bracket frame. The stainless steel slid rods were and the syntactic foam float were clean. This bracket was anti-fouled in the same manner as the Brancker temperature pipe.

The results of the PACS 2 test in conjunction with the results of the previous test (Trask, et al, 1998) done on PACS 1 have shown repeatable results. The No Foul SN-1 will perform with an adequate mil thickness as well as Tribyutal tin base antifoulants. although, No Foul SN-1 does not bond to the substrates tested as well as the standard coatings, Micron-33 or Ameron 635. The reduction of the width of the control stripe in the second test possibly reduced the fouling potential of the control due to halo effects from the coatings test. Results from the small test areas, Reltec and the Magellan paints showed promise but due to the small surface are tested and their position around the discus hull possibly encouraging or discouraging fouling due to current flow and wave action could be considered to be inconclusive. These coatings should be incorporated in further testing where the surface areas would be similar to the Micron-33 and No Foul SN-1. Testing should be done as well to develop a coating or technique to protect plastic components from gooseneck barnacle fouling. Table A8-2 and Table A8-3 detail the visual observation taken for the PACS 1 and PACS 2 discus hulls.

Table A8-2: Antifouling coating performance, PACS 1, North and South

Exposure: 9 months (April to December 1997); Nominal application thickness of 8 mils (2 coats).

Sample	Color	Ablation*	Adhesion**	Fouling†	Algae film
No Foul SN-1	White	80%	poor	<10%	100%
Pettit Alumacoat	Black	80%	good	<10%	100%
Ameron 635	White	50%	good	<10%	50%
Control	Yellow	na	na	100%	100%

* Ablation was estimated based on visual observation at time of recovery
**Adhesion of the remaining coating was evaluated during high pressure washing.
† Primarily Lepas gooseneck barnacles with nominal lengths of 5"

Table A8-3: Antifouling coating performance, PACS 2, North and South

Exposure: 9 months (December 97 to September 98)

Sample	Color	Ablation*	Adhesion**	Fouling†	Algae film
No Foul SN-1	White	80%	poor	<10%	100%
Micron-33	Blue	80%	good	<10%	100%
Bondit B-2	Clear	na	na	<10%	50%
MAG-CAP	Gray	50%	poor	<10%	50%
MAG-BIO	Gray	100%	poor	0%	50%
Control	Yellow	na	na	100%	100%

* Ablation was estimated based on visual observation at time of recovery
**Adhesion of the remaining coating was evaluated during high pressure washing.
† Primarily Lepas gooseneck barnacles with nominal lengths of 5"

DOCUMENT LIBRARY

Distribution List for Technical Report Exchange - July 1998

University of California, San Diego
SIO Library 0175C
9500 Gilman Drive
La Jolla, CA 92093-0175

Hancock Library of Biology & Oceanography
Alan Hancock Laboratory
University of Southern California
University Park
Los Angeles, CA 90089-0371

Gifts & Exchanges
Library
Bedford Institute of Oceanography
P.O. Box 1006
Dartmouth, NS, B2Y 4A2, CANADA

NOAA/EDIS Miami Library Center
4301 Rickenbacker Causeway
Miami, FL 33149

Research Library
U.S. Army Corps of Engineers
Waterways Experiment Station
3909 Halls Ferry Road
Vicksburg, MS 39180-6199

Marine Resources Information Center
Building E38-320
MIT
Cambridge, MA 02139

Library
Lamont-Doherty Geological Observatory
Columbia University
Palisades, NY 10964

Library
Serials Department
Oregon State University
Corvallis, OR 97331

Pell Marine Science Library
University of Rhode Island
Narragansett Bay Campus
Narragansett, RI 02882

Working Collection
Texas A&M University
Dept. of Oceanography
College Station, TX 77843

Fisheries-Oceanography Library
151 Oceanography Teaching Bldg.
University of Washington
Seattle, WA 98195

Library
R.S.M.A.S.
University of Miami
4600 Rickenbacker Causeway
Miami, FL 33149

Maury Oceanographic Library
Naval Oceanographic Office
Building 1003 South
1002 Balch Blvd.
Stennis Space Center, MS, 39522-5001

Library
Institute of Ocean Sciences
P.O. Box 6000
Sidney, B.C. V8L 4B2
CANADA

National Oceanographic Library
Southampton Oceanography Centre
European Way
Southampton SO14 3ZH
UK

The Librarian
CSIRO Marine Laboratories
G.P.O. Box 1538
Hobart, Tasmania
AUSTRALIA 7001

Library
Proudman Oceanographic Laboratory
Bidston Observatory
Birkenhead
Merseyside L43 7 RA
UNITED KINGDOM

IFREMER
Centre de Brest
Service Documentation - Publications
BP 70 29280 PLOUZANE
FRANCE

REPORT DOCUMENTATION PAGE	1. REPORT NO. WHOI-99-06	2. UOP 99-01	3. Recipient's Accession No.
4. Title and Subtitle Pan American Climate Study (PACS) Mooring Recovery Cruise Report • R/V Melville Cruise PACS03MV 6 September to 30 September 1998		5. Report Date May 1999	6.
7. Author(s) William M. Ostrom, Bryan S. Way, Steven P. Anderson, Brent Jones Erica Key, Gabriel Yuras		8. Performing Organization Rept. No. WHOI-99-06	
9. Performing Organization Name and Address Woods Hole Oceanographic Institution Woods Hole, Massachusetts 02543		10. Project/Task/Work Unit No.	
		11. Contract(C) or Grant(G) No. (C) NA66GP0130 (G)	
12. Sponsoring Organization Name and Address National Oceanic and Atmospheric Administration		13. Type of Report & Period Covered Technical Report	
		14.	
15. Supplementary Notes This report should be cited as: Woods Hole Oceanog. Inst. Tech. Rept., WHOI-99-06.			
16. Abstract (Limit: 200 words) Two surface moorings were recovered during R/V <i>Melville</i> cruise PACS03MV in the eastern equatorial Pacific as part of the Pan American Climate Study (PACS). PACS is a NOAA-funded study with the goal of investigating links between sea-surface temperature variability in the tropical oceans near the Americas and climate over the American continents. The two moorings were deployed near 125°W, spanning the strong meridional sea surface temperature gradient associated with the cold tongue south of the equator and the warmer ocean north of the equator, near the northernmost, summer location of the Intertropical Convergence Zone. The moored array was deployed to improve the understanding of air-sea fluxes and of the processes that control the evolution of the sea surface temperature field in the region. Two surface moorings, located at 3°S, 125°W and 10°N, 125°W, belonging to the Upper Ocean Processes (UOP) Group at the Woods Hole Oceanographic Institution (WHOI), were recovered after being on station for eight months. This was the second setting of the two moorings that had been redeployed from the University of Washington's R/V <i>Thomas Thompson</i> cruise number 73. The buoys of the two WHOI moorings were each equipped with meteorological instrumentation, including a Vector Averaging Wind Recorder (VAWR), and an Improved METeorological (IMET) system. The WHOI moorings also carried Vector Measuring Current Meters, single point temperature recorders, and conductivity and temperature recorders located in the upper 200 meters of the mooring line. In addition to the instrumentation noted above, a variety of other instruments, including an acoustic current meter, acoustic doppler current meters, bio-optical instrument packages and an acoustic rain gauge, were deployed during the PACS field program. This report describes, in a general manner, the work that took place during R/V <i>Melville</i> cruise PACS03MV. A description of the WHOI moored array and instrumentation is provided. Details of the mooring designs and preliminary data from the CTD profiles are included.			
17. Document Analysis a. Descriptors air-sea interaction moored instrument measurements PACS: eastern tropical Pacific b. Identifiers/Open-Ended Terms c. COSATI Field/Group			
18. Availability Statement Approved for public release; distribution unlimited.		19. Security Class (This Report) UNCLASSIFIED	21. No. of Pages
		20. Security Class (This Page)	22. Price 74