

340139

JPRS 84630

27 October 1983

# East Europe Report

SCIENTIFIC AFFAIRS

No. 792

**DISTRIBUTION STATEMENT A**  
Approved for Public Release  
Distribution Unlimited

19990730 046

**FBIS**

FOREIGN BROADCAST INFORMATION SERVICE

REPRODUCED BY  
NATIONAL TECHNICAL  
INFORMATION SERVICE  
U.S. DEPARTMENT OF COMMERCE  
SPRINGFIELD, VA. 22161

5  
73  
Ad4

#### NOTE

JPRS publications contain information primarily from foreign newspapers, periodicals and books, but also from news agency transmissions and broadcasts. Materials from foreign-language sources are translated; those from English-language sources are transcribed or reprinted, with the original phrasing and other characteristics retained.

Headlines, editorial reports, and material enclosed in brackets [] are supplied by JPRS. Processing indicators such as [Text] or [Excerpt] in the first line of each item, or following the last line of a brief, indicate how the original information was processed. Where no processing indicator is given, the information was summarized or extracted.

Unfamiliar names rendered phonetically or transliterated are enclosed in parentheses. Words or names preceded by a question mark and enclosed in parentheses were not clear in the original but have been supplied as appropriate in context. Other unattributed parenthetical notes within the body of an item originate with the source. Times within items are as given by source.

The contents of this publication in no way represent the policies, views or attitudes of the U.S. Government.

#### PROCUREMENT OF PUBLICATIONS

JPRS publications may be ordered from the National Technical Information Service, Springfield, Virginia 22161. In ordering, it is recommended that the JPRS number, title, date and author, if applicable, of publication be cited.

Current JPRS publications are announced in Government Reports Announcements issued semi-monthly by the National Technical Information Service, and are listed in the Monthly Catalog of U.S. Government Publications issued by the Superintendent of Documents, U.S. Government Printing Office, Washington, D.C. 20402.

Correspondence pertaining to matters other than procurement may be addressed to Joint Publications Research Service, 1000 North Glebe Road, Arlington, Virginia 22201.

27 October 1983

# EAST EUROPE REPORT SCIENTIFIC AFFAIRS

No. 792

## CONTENTS

### INTERNATIONAL AFFAIRS

#### Briefs

Conference on Computers	1
Interkosmos Symposium	1
Microelectronics Conference	1
Nuclear Electronics Conference	1

### GERMAN DEMOCRATIC REPUBLIC

#### Briefs

Biotechnology Research	2
------------------------	---

### HUNGARY

Small Computer Application in the ASZSZ Network (Imre Csere, Laszlo Gilicze; <u>INFORMACIO ELEKTRONIKA</u> , No 3, 1983) .....	3
ADT 7300 Hybrid Computer System (Zoltan Benyo; <u>MERES ES AUTOMATIKA</u> , No 11, 1982) .....	15
ES 1026: First Approved Member of ESR 2/II Series (Janos Greiner; <u>SZAMITASTECHNIKA</u> , May 83) .....	26
SCI-L: New Systems Computer Information Lab (Pal Nemeth Interview; <u>SZAMITASTECHNIKA</u> , May 83) .....	32
ISKRA-226 Small Computer ( <u>SZAMITASTECHNIKA</u> , May 83) .....	37
Program for Computerization To Be Made More Comprehensive ( <u>SZAMITASTECHNIKA</u> , Jun 83) .....	39
Catalogue of 1981 Computer Programs (Karoly Geher; <u>HIRADASTECHNIKA</u> , No 6, 1983) .....	45

Electronic Telephone System (HIRADASTECHNIKA, No 8, 1983) .....	50
Notable Hungarian Achievements in Prolog Applications (Gabor Pal Peto; NEPSZABADSAG, 23 Aug 83) .....	52
Abstracts	
Computers and Automation Technology .....	56
Electronics and Electrical Engineering .....	59
Engineering and Equipment .....	66
Materials Science and Metallurgical .....	67
Briefs	
Size of Computer Park .....	68

## BRIEFS

CONFERENCE ON COMPUTERS--Compcontrol, a 3-day international conference on the use of computers in engineering, opens in Bratislava today. It will be attended by 360 experts from the Soviet Union, Hungary, the GDR, Poland, Bulgaria, Romania, the United States, the FRG, Japan, France, Norway, Denmark, and the CSSR, who will discuss the use of computers in management, production and technological processes, machine design, and other areas. [Summary] [Bratislava PRAVDA in Slovak 13 Sep 83 p 2 AU]

INTERKOSMOS SYMPOSIUM--Within the framework of the Interkosmos program, a session of the Work Group for the Long-Distance Exploration of the Earth opened in Prague on Tuesday. The symposium is attended by prominent scientists from the Soviet Union, the GDR, and Poland. Together with our experts, they will assess the problems connected with the development of equipment for the thermal representation of the earth's surface from planes and artificial satellites. [Text] [Prague RUDE PRAVO in Czech 7 Sep 83 p 2 AU]

MICROELECTRONICS CONFERENCE--The 3-day Third Czechoslovak Conference on Microelectronics with international participation, which opened in Bratislava yesterday, discusses the current scientific-technical problems of microelectronics and its application in practice. The more than 150 participants from Bulgaria, Yugoslavia, Hungary, the GDR, Poland, Romania, the USSR, and the CSSR will familiarize themselves in four sections with the latest findings in microelectronics. [Summary] [Bratislava PRAVDA in Slovak 7 Sep 83 p 2 AU]

NUCLEAR ELECTRONICS CONFERENCE--Current problems of nuclear electronics are the subject of an international conference that opened in Bratislava yesterday. The conference, which is organized by the Comenius University in Bratislava, the Nuclear Research Institute in Dubno near Moscow, and the Czechoslovak and Slovak Academies of Sciences, together with the Tesla enterprises in Piestany and Vrable, is attended by more than 180 experts from the CSSR, Bulgaria, Yugoslavia, Cuba, the DPRK, Hungary, the GDR, the FRG, Poland, Romania, Austria, Switzerland, Italy, the SRV, and the USSR. The week-long conference will deal, among other things, with spectrometrical electronics, with fast processors for the selection of information, and with the use of micro- and small computers in directing physical experiments. [Summary] [Bratislava PRAVDA in Slovak 7 Sep 83 p 2 AU]

GERMAN DEMOCRATIC REPUBLIC

BRIEFS

BIOTECHNOLOGY RESEARCH--The Institute for Chemical Engineering in Leipzig has set itself the goal of developing processes for the production of phototropic microorganisms/biomasses and of contributing toward the solution of energy and raw material problems through studies geared toward application. The Colloquium "Photosynthesis in Biotechnology" planned for 22 September 1983 in Leipzig will represent an important step in this direction. [Excerpt] [East Berlin SPECTRUM in German Vol 14 No 8, Aug 83 p 17]

CSO: 2302/3

SMALL COMPUTER APPLICATION IN THE ASZSZ NETWORK

Budapest INFORMÁCIO ELEKTRONIKA in Hungarian No 3, 1983 pp 141-148

[Article by Imre Csere and Laszlo Gilicze: "Network Applications of Small Computers in the ASZSZ"]

[Text] As far as we know the State Administration Computer Service [ASZSZ] of the KSH [Central Statistics Office] not only operates one of the largest-capacity computer centers of the country but also operates the largest network of terminals. About 80 terminals are now connected to the CII Honeywell Bull 66 central computers. Despite this the various systems technology solutions are known to a relatively narrow circle. In this article we will deal with the ASZSZ network and with the circumstances of the use of the several terminals. In reviewing the terminal types we will emphasize the small computers and among these the network application of the TPA 11/40 and PDP 11/40.

(Arrived: 21 October 1982)

Introduction

The ASZSZ computer center of the KSH has been operating since 1976 and its terminal network has been operating for 5 years. And yet its achievements and experiences are relatively little known. The experiences merit attention not only because of the large number of terminals and because of the solutions of the CII Honeywell Bull (hereinafter, Honeywell) which differ from other systems but also because for the first time in our homeland use is being made in an operational way of a few operationally modern methods. Among these we might mention the network control (front-end) computer, the high data transmission speeds, the prolonged operation of the remote batched operating terminal and concentrator, the automatèd "complex" data recording and the network application of multifunction small computers. In what follows we will report on a few experiences acquired with these.

Aspects of Network Formation in the ASZSZ

The central idea which led to the creation of the ASZSZ computer center was that to computerize a few of the large national information systems (for example,

population records and real estate records) we would need a large-capacity computer center which was suitable for multilateral access and thus could be used jointly by the interested institutions. Under the conditions at that time, as a result of the many services and the relative price of acquisition, acquiring the Level 66 computer system of the Honeywell Bull firm proved most advantageous. In addition, significant viewpoint was the Honeywell solution for handling networks--a network control computer and "multidimensional" access (parallelism of operating modes). This made possible later expansion--to a significant degree from domestic sources--in a direction corresponding to the central goal.

The course of expansion of the terminal network was governed by what network services of the Honeywell could be used with domestic data transmission possibilities.

On the one hand the Honeywell's data transmission procedures differ from those used here--they are not based on binary synchronous communication (BSC). On the other hand the relative backwardness of the domestic data transmission microstructure (existence of line links, transmission speeds) is well known. It also represented a difficulty that similar domestic experience was lacking and the actual network user needs could be surveyed only cautiously and with very great imprecision.

Under these conditions the initial goals in the development of the network were the following:

1. We should build the terminal network primarily with domestic equipment--even at the price of new developments. To ensure compatibility, we purchased one each original "prototype" from the Honeywell firm; it was thus possible to save substantial capitalist import.
2. We should select a range of terminal types to be included in the network which was sufficiently broad that the already existing equipment of our users should be compatible, in addition to the main terminal types, because new hardware investment was very expensive.
3. We should expand the range of individual terminal types so that we would have available flexible devices appropriate for more and more purposes. In this way a solution could be suggested even in the event of uncertain or changing needs.
4. The first task was to place conversational terminals into operation. With the aid of these it would be possible to access the computer from all user sites in the period of developing applications.

In essence we have already carried out the initial goals pertaining to development of the network, despite many constraining factors. The first step, providing users with conversational terminals, took place even earlier. Citation 2 reports on this status of the ASZSZ network. At present we can already offer a sufficient variety in the area of intelligent terminals and network small computers by connecting the appropriate mini- and microcomputers. The range of computer types and of the possibilities or functions which can be realized on them is sufficiently broad that even larger distributed applications should be realizable. [12].

Before we turn to a description of the role of the several small computers, we should briefly describe that network management procedure of the Honeywell used in the ASZSZ, which has found numerous applications and followers around the world--even if it no longer counts as the most modern. This procedure makes it possible for the access problems arising from the large number of user sites to be at least tolerable.

#### The Network Services of the GCOS

On the basis of the modularity of system technology and the principle of distributed control, control of the network is also distributed in the Honeywell system. A separate network control small computer, the so-called front-end processor, takes care of the great majority of the network management functions. Depending on the network structure, certain functions (concentration, buffering, conversion) fall on the terminals. Thus the multiplicity of terminals does not represent a great burden for the central computer. The operating system, the GCOS, can handle the several terminals as uniform I/O devices independent of their distance and type.

The network-controlling small computer solution makes it possible for the GCOS to have many-sided network services. Among these we might mention parallelism of operational modes, the multiplicity of conversational services and the logical terminal identification system supporting operation.

#### Parallelism of Operational Modes

The parallelism of operational modes, "multidimensional" access in the GCOS terminology, means that a number of access modes are available simultaneously on the central computer--local and remote batch, conversational and direct (the so-called DAC) modes. Batched operation of the GCOS is accessible through the remote batched mode. Batched jobs can be run even from a distance without limitation--the GCOS makes no distinction between jobs started locally and from a distance. It is also possible to run batched jobs from under conversational operation. In any case the conversational mode offers the possibility for various short-response operations. If there is a network application for which neither is applicable, then a new goal system can be worked out with the tools of direct access, of DAC [13]. We can also prepare programs--with assembler or high-level program language tools--which, running in the center, can communicate with one or more terminals in a previously programmed manner. With the DAC tools, for example, special information structures can be transmitted and various end equipment or multiterminal applications can be developed. All three access modes operate simultaneously and the user chooses, when signing in on the terminal, which one he wants to work in. Naturally, the type of terminal (conversational or batched) can represent a restriction in this.

#### Conversational Services

The multiplicity of conversational services merits special attention. Running batched jobs is a popular, well-proven possibility, especially to increase the efficiency of program development work. But the turnaround time of jobs is decreased significantly by the fact that the run results can be analysed and

20

corrected immediately without operator intervention--in the conversational mode, in a time-sharing system (TSS). Querying and maintaining data bases, text-editing operations, data file manipulations, trace following, timed processing and many other favored possibilities are available in addition to a few high-level, conversational languages. In the conversational mode there are also transaction systems (TPS, TDS), but at present there is no need for these. We should not that running large conversational data base applications is clumsy; it would need larger central and background storage than can be attained at present.

#### Logical Terminal Identification

We should mention one other Honeywell network service and this is the system of logical terminal identification. The terminal identifier is the so-called ID, consisting of two characters, which is given or indicated at the terminal when signing on. The great advantage of the logical terminal identification system is that we can sign on from an optional point of the network and redirect the run results to the given ID--frequently the results are needed elsewhere. The condition for signing on, naturally, is a knowledge of the appropriate identifiers and passwords. This system also represents a flexible possibility for transfer of applications, which is advantageous from the convenience and security viewpoint alike.

#### Equipment Used in the ASZSZ Network

The equipment used in the ASZSZ network is extraordinarily varied compared to the size of the network. The number of data transmission procedures (protocols) is more than 5 and the number of types of connected equipment is above 10. Simultaneous and efficient handling of these is made possible only by the distributed nature of network control.

#### The Network Control Computer

The network control, front-end computer is a fast, 64-K-word small computer [1]. The present network control software, the GRTS II, is the third to be used in operation of the ASZSZ network [8]. The first, the GRTS, was not capable of handling all terminal types at once. So several versions were operated alternately and the network operation of the several terminals had to be limited in time. Another network control software, the NPS, would have required use of one of the magnetic disks of the central computer, but this sacrifice was not justified by the many services of the NPS (maintaining a journal, message switching, etc) which were not needed in the existing applications. So this was used for only a brief time as an experiment.

The GRTS II has been in operation for 2 years. It can handle all the terminal types (averaging 16-20 during a day but at most 36 terminals at present) at one time without a noticeable decrease in response time.

We can group the types of equipment in the network as follows:

--conversational terminals,

- remote batched terminals.
- microcomputers which can be used as terminals,
- intelligent terminals and
- complex terminals.

This listing happened as a result of increasing complexity. Acquisition difficulties justify the many different types of equipment; we had to be able to connect the various types of equipment already existing. The recognition that the sphere of tasks which could be handled by the several types of equipment should be expanded where the type of equipment permitted it led to the development of the various stages of complexity. We attempted to satisfy the changing and expanding needs by expanding the software [3].

Figure 1 shows a schematic of the ASZSZ network, designating the type and function of a few terminals.

#### Conversational Terminals

We might say briefly about the conversational terminals only that they are cheap (several hundred thousand forints), as are the most basic tools for access to the computer. Depending on the data transmission procedure used, there are two types of terminals in the ASZSZ network--a=synchronous and asynchronous.

The former include the Teletype type terminals (ASR 33, Terminet 1200) and picture screen terminals (VT 340, VSD). The central computer can be accessed also via the national telex net, but thus far this has been done only experimentally as there is no need for it. It is a common characteristic of the asynchronous terminals that they are slow (10-30 characters per second), that they use transmission line for line and that there is little possibility for checking transmission errors (cross parity).

The synchronous terminals are connected to the net with the so-called VIP data transmission procedure. This makes possible substantially greater speeds (about 120-960 characters per second), reliable error checking and the simultaneous handling of several lines, even an entire screen, as well as printer and magnetic cassette. Thus they can be used as ideal data input and program development stations. Several pieces of equipment can run on one data transmission line with the aid of the multiplexer developed in the ASZSZ. There is one original VIP 7750 terminal but the majority of the equipment is VTS 56100 and VDT 52100. These are Honeywell-compatible versions prepared in cooperation with Videoton and the ASZSZ [4]. A graphics screen can also be connected to the VDT 52100.

#### Remote Batched Terminals

In this category we list those simple devices which have the single task of producing a link with the batch operation of the central computer. With the aid of these job runs can be done on remote large computers. Equipment to carry out this function alone is not run in the ASZSZ but it is possible to connect, for example, IBM 2780 or GE 115 equipment--or equipment emulating these.

## Microcomputers Which Can Be Used As Terminals

This category includes those microcomputers working as terminals which can be programmed also. When switching between local and network operation the operating programs can be loaded from background storage (for example, from cassette). Such equipment operating in the ASZSZ network includes one HP 9830A, two DATAPOINT 2200's and an MTS 7500, which is sold by Honeywell and equivalent to the latter:

In 1979 the Hewlett-Packard 9830A calculator owned by the ERTI [Scientific Institute of Forestry] was connected to our central computer with an IBM 2780 data transmission protocol. The equipment has a slow-card reader, a slow-line printer, a (tiny) digitizer and a plotter. It has an alphanumeric keyboard, a 32-character display and a magnetic cassette unit. From the latter one can load programs and the BASIC interpreter.

Scientific forestry calculations are done on the configuration described. When there is need for the large capacity of the Honeywell or its broad range of software services, the line-handling program can be loaded simply and the machine used as a remote batched terminal. A similar role is played by the DATAPOINT 2200 at the VGI and the MTS 7500 at the ASZSZ. The difference is that these terminals, in contrast to the former, use the conversational-line procedure. These devices are examples of how the services of the central large computer can be used usefully and conveniently with various peripherals and target software.

## Intelligent Terminals

By intelligent terminals we mean those small computers which can be used for local programming and runs in addition to and parallel with the terminal function. Naturally these can be used as independent computers when the line connection is not working. Such equipment in the ASZSZ network includes the system developed by SZAMKI [Computer Technology Research Institute] for the RTDM monitor of the ES 1010 computer [5] and the DATANET 707 small computer of the Honey well firm.

The processing and storage capacity of small computers is suitable for carrying out developed network functions. Both pieces of equipment can handle the traffic of several terminals on a single physical line as a "logical" terminal, with the aid of MMI, an interesting data transmission procedure of Honeywell. The MMI makes possible various types of logical terminals. For example, one can realize in parallel a complex operation where one logical terminal prints the job output, a second accepts output on magnetic tape (for off-line printing later), while a third can inquire about the status of other runs, etc. These devices can satisfy the computer access needs of larger program development associations or more intensive user needs. They not only relieve the burden on the I/O units of the central computer but also substantially shorten the turnaround times of jobs, because one does not have to wait for service or for the transportation of data carriers.

In the absence of user need the intelligent terminal developed for the ES 1010 computer has been run only a few times as an experiment. Most recently it was

used in a Baja-Dudapest link on the private line of the Water Affairs Directorate. The DATANET 707 terminal, on the other hand, has been used constantly for 5 years, and it is a popular tool for a main department dealing primarily with software development and data base building. This equipment is suitable for concentrating conversational terminals in addition to remote batched operation. In the present arrangement the computer access needs of about 60 workers with a total of 6 conversational terminals and 5 remote batched logical terminals are being satisfied via a single leased telephone line. The transmission speed is 9,600 bits per second with the aid of a base band modem.

We should mention here that the IBM 360/370 and the higher-series number computers of the ESR can be connected to the ASZSZ network also, as remote batched terminals. This link has been operated a few times but only as an experiment, because the network software greatly limits local operation of the computer.

### Complex Terminals

In addition to network and local processing the modern small computers can be used for a number of tasks which are certainly necessary in the large computer environment. In the usage which has developed in our institute we call the small computers carrying out such tasks complex terminals, referring to the fact that the network end equipment is suitable for carrying out an entire range of complex services. Because they are cheap, the small computers can be used for tasks which could not be carried out economically with a large computer in a large computer environment; they can be used as independent small computers or for distributed processing, thus uniting the two.

The following functions or tasks can be done economically on small computers operating in a large computer environment:

- grouped data recording,
- code conversion, data carrier transformation,
- remote batched terminal,
- line concentrator and
- programmed local runs.

We tried to harmonize these functions with the development of existing software conditions on suitable equipment available to the ASZSZ--an INTERSCAN (GCS) 2100 and a TPA (PDP) 11/40. This goal of function combination is justified by the fact that one of the most modern small computers, the Honeywell MINI 6, offers this same parallelism of services and a gigantic number were sold immediately following release.

Figure 2 summarizes the several functions operating on equipment in the ASZSZ net.

It can be seen from the figure that the INTERSCAN 2100 and the TPA 11/40 were the devices best approximating the ideal of a complex terminal. Thus far there has been no need for such use of the ES 1010 computer. On the DATANET 707, however, we achieved a further development of the software delivered by Honeywell to the point where local processing can be run in parallel with network processing. This possibility can hardly be used, however--the operating system is memory resident, the network control software occupies the overwhelming part (32 K) of the memory, and thus only insignificant programs can be run.

The INTERSCAN 2100 is a special-purpose, grouped data recording system which was intended to satisfy the data input needs of large information systems. In cooperation with the manufacturer we expanded the data movement possibilities connected with data input so that code transformation from the codes used in the user environment of the ASZSZ can be an operator task, while the broad peripheral assortment makes possible the movement of files between different data carriers--even during code transformation (the conversion function). Operations needed from time to time during large processings, for example input from punch tape or off-line printing with accented Hungarian characters, can be done economically on the INTERSCAN. The remote batched function well supplements the grouped data recording--files received as the result of recording (and already partially checked) can be forwarded via the net immediately to the large machine. This service is what we mean by complex data recording. After large computer checking the error list returns on line and we can correct the errors in the conversational mode, thus substantially shortening the data input cycles. Running remote jobs is possible also (remote batched function) and in combination with local conversational correction offers possibilities for conversational program development. With regularly running data input and conversion this equipment can satisfy the needs of smaller groups for access to the central machine. There are four INTERSCAN 2100's in the ASZSZ network.

The TPA 11/40 with maximal software, shown in Figure 2, does not yet work regularly in the ASZSZ net. The network connection is an achievement of the recent past [11]. At present initial applications experiments are under way in two installations. Quite varied equipment can be developed with the aid of the software available. The domestically obtainable program packages DECFORM, SERIES IV, etc are suitable for satisfying data input needs. We can find auxiliary programs suitable for conversion tasks as services of the operating systems. Under the RSX-11M operating system we can link up to the Honeywell net. The GCOS can be used for transmitting data files in addition to its batched and conversational services. And the local services in the operating system are all available in addition to the above (under RSX-11M we have FORTRAN, BASIC, DIBOL, text editors, trace following possibilities, data base management, etc).

Let us turn in more detail here to a few services of the TPA-Honeywell link which the experiences of several years of operating the INTERSCAN and the DATANET led to. Let us mention first the parallelism of services, by means of which we get very flexible equipment. The programmers (or operators) at the terminals of the TPA can freely select with the appropriate commands whether to use the time sharing services of (1) the RSX or (2) the GCOS or (3) whether to run a remote batched job under GCOS or whether they want to upload or down-

1

load a data file [4]. Any number of terminals can work at the same time with the Honeywell in the desired mode. The data transmission procedure (MMI) makes this possible. As an example, we present the scheme of the sign on procedure in Figure 3.

In addition to the parallelism of services we should stress the data file transmission possibilities of the TPA 11/40 terminal. It is one of the bitter experiences in remote batched runs that getting the data carriers to the place of processing is clumsy. One must reckon not only with the inconveniences of transportation but also with compatibility difficulties due to differing operating system conventions. (For example, the transfer of magnetic tape data files between DOS, RSX and GCOS was solved for one application with several months' work. This was proven in practice too but this development had to be repeated because there is a need for multiple file tapes.) These difficulties are eliminated when files are transmitted on line because the computer on both sides works with its own convention. Handling the transmission can be a simple operator task. One can transmit files from all peripheral units handled by RSX and transparent transmission is possible also. Experience has shown that transmission speeds of 9,600 bits per second can be realized within Budapest, thus the time for transmission of entire magnetic tape files is not too much.

It is a further advantage of the TPA 11/40 that with the tools available the development of distributed data processing systems can be an applications programming task. There is need for such a development even with the large-capacity Honeywell. In general it is useful to use a small computer for tasks requiring greater interactivity (data input, correction, listing in multiple copies or on preprinted paper, etc). Processing done more rarely, with large volumes of data (data base maintenance, sorting), can be run on the large machine [14].

Finally let us give an example of how small computers in a common net can help in coordinating and making more convenient the work of various institutions and groups. In Figure 4 we show the devices and the locations of the affected work groups in a geodetic and mapping records system being developed jointly by the BGTV [Budapest Geodesy and Cartography Enterprise] and the ASZSZ and not some of the partial tasks. The data to be used in the data base are compiled at the BGTV as magnetic tape files. We developed the simple (FORTRAN) programs needed to transmit the files at our Lajos Street installation using a conversational terminal. We sent the list of finished programs, by output transfer, to Bosnyak Square, from which the data file is read in with this program. The Szekely Bertalan Street installation is informed of the arrival of the file at the central machine so that the output of the file transfer program goes to Szekely Bertalan Street instead of Bosnyak Square. Data base maintenance operations are controlled from here. We thus eliminated several file conversions, transportation and travel and every work group is informed automatically without delay about the ability to continue the work. Processing in the opposite direction can be solved similarly with appropriate redirection of the lists.

#### ASZSZ Experiences

In the foregoing we have reviewed the varied applications possibilities of the terminals and small computers in the ASZSZ net. But in reporting on the possi-

bilities we must state that the network applications are hardly used systematically--with the exception of the popular conversational program development [9 and 10]. In the following we will try to summarize the causes which may have led to the actual distrust, frequently even antipathy, which resulted in the passivity toward network applications.

The data transmission microstructure in our homeland reflects the neglect of recent decades. There are not enough postal cables, building up leased lines requires time, the reliability of connected lines is not adequate, especially in the case of provincial links, and the line speed which can be attained is small. What can give cause for optimism in this area is the recent efforts of the Hungarian Postal Service. But it is also found that the many difficulties accompanying experimental operation of a data transmission link frighten off the user even if the reliability of the existing links is good.

Maintenance difficulties are substantially greater for network applications. This derives from the fact that there are few experts at home in a number of areas and the failure of the equipment needed in the links is more frequent--as a result of the large number of devices. The maintenance work conditions are more disadvantageous (distances, lack of testing equipment, difficulty of communication among maintenance experts). But if the maintenance tasks are taken care of by the developers in the beginning, the initial difficulties can be avoided and the link will work. Routine organization of maintenance can be a later task.

We mentioned already that remote applications are hindered by difficulties connected with transmission of data files. Data files can be transmitted on remote batched terminals. It is true that the transmission speed is small for transmitting large volumes of information but still we can find a solution in some of the cases. For example, according to our experience in Budapest a transmission speed of at least 9,600 bits per second can be attained with base band transmission. The DATANET 707 works for days without a line error (that is, without repeats) at this speed (about 50 million bits per day without error). For safety we could design applications systems that included transfer on magnetic tape as well as remote data transmission. This alternative possibility would mean security in the event of failure of the remote data transmission equipment. The original goals in building the ASZSZ network included the development of a broader range of network services, with additional investment. In the present economic situation, however, a more significant further development of the network cannot be realized on our own. Further development can be realized only with the joining together and joint efforts of the affected institutions and with closer cooperation of experts in the several special fields.

#### Summary

The examples given can reassure us that even under present conditions those using computer technology can count on many-sided services.

But many possibilities remain unexploited or in only an experimental stage in the area of network applications. This backwardness of user demand holds back the development of further applications and system technology. It is under-

standable that a determined need does not develop in the absence of reliable and fast network services. This is a vicious circle from which we must find a way out if we want to realize swift, accurate, timely information services with tools which make human work easier; for this is the significance of networks.

#### BIBLIOGRAPHY

1. Datanet 6600 Front-end Network Processor System Manual BS03. Rev. 1.
2. Cs. Cserna: "The ASZSZ Remote Processing Network," INFORMACIO-ELEKTRONIKA, 1976, p 6.
3. L. Gilicze: "Experiences in Integration of Small Computer Functions at ASZSZ," Programming Systems Conference, Szeged, 1978, p 239.
4. O. Kovacs and P. Gati: "Terminal Connection to the CII-HwB 66 System," Programming Systems Conference, Szeged, 1978, p 329.
5. I. Foldvari, Z. Laborczi, Mrs J. Mink and P. Rajki: "Intelligent Terminals and Concentrators," Programming Systems Conference, Szeged, 1978, p 202.
6. I. Csere and P. Margitics: "Development of the Datanet 707 System," ASZSZ internal documentation, 1978.
7. L. Gilicze: "Network Software of the ASZSZ," SZAMITASTECHNIKA, May 1979.
8. K. Varga and Cs. Cserna: "The Network Control System Programs and Applications Systems of the ASZSZ Network," Computer Network Models, Spring School, Szeged, 1980, pp 5-53.
9. Dr L. Bozoky, Mrs Zs. Harnos and P. Gati: "A Computerized National Radius Planning Network," INFORMACIO-ELEKTRONIKA, 1979, p 6.
10. T. Gorgey: "A Report on the National Instrument Registry," MUSZERUGYI ES MERESTECHNIKAI KOZLEMENYEK, 1978, p 25.
11. L. Gilicze: "Use of the TPA 11/40 in the CII-Honeywell Bull Central Network," SZAMITASTECHNIKA, 1982.
12. P. Gati and Cs. Cserna: "Remote Data Processing Offers for ASZSZ Users," ASZSZ internal documentation, 1981.
13. Cs. Cserna: "Accessing Interactive Terminals from an Applications Program (DAC)," ASZSZ internal documentation, 1978.
14. Z. Bodi: "Distributed Data Processing Systems," SZAMOK, 1981.

## Description of Figures

Figure 1 shows the central computer, a 1 BM CII Honeywell Bull 66/20 D, connected directly to the network control computer. The latter is connected directly to a keyboard a=synchronous terminal and indirectly to several a=synchronous display terminals, to several synchronous display terminals and to an INTERSCAN 2100, a A DATANET 707 and a TPA 11/40, all three of the latter connected directly to a number of peripherals.

### Figure 2

Type:	INTERSCAN 2100	ES 1010	DN 707	TPA 11/40
Small computer function:				
Data recording	in operation	with special system	--	in operation
Conversion	in operation	partial	--	in operation
Remote batched	in operation	in operation	in operation	in operation
Concentrator	--	planned	in operation	in operation
Local processing	not in operation	in operation	simultaneous with limits	in operation

Figure 3 is flow chart for signing on from an RSX terminal. There are three choice points after signing on under RSX: "Do I want to work on the Honeywell?"; if "no," RSX operation is chosen; if "yes," the next choice is "Is Honeywell network control working?"; if "no," the network control software is loaded with one or two commands; if "yes," the next choice point is "Do I want to work in the time-sharing mode?"; if "no," there can be remote job runs or transmission of files; if "yes," one signs into the GCOS time-sharing mode and finally terminal use is as in the case of direct GCOS terminals.

Figure 4 shows a distributed network application. The data base is handled by the CII Honeywell Bull 66/20D at the ASZSZ on Csalogany Street, District I. This is connected remotely to three other installations: the PDP 11/40 of the BGTV on Bosnyak Square, District XIV, for data input, conversion and map drawing; a DATANET 707 at the ASZSZ, Szekely B. Street, District VI, for data base maintenance and control of processing; and an MTS 7500 of the ASZSZ on Lajos Street, District III, for development of data file transmission programs.

8984

CSO: 2502/83

## ADT 7300 HYBRID COMPUTER SYSTEM

Budapest MERES ES AUTOMATIKA in Hungarian No 11, 1982 pp 401-406

[Article by Dr Zoltan Benyo of the Process Control Faculty of the Budapest Technical University: "The ADT 7300 Hybrid Computer Model System"]

[Text] Intensive research work on the theme of system simulation has been going on for a long time at the Process Control Faculty of the BME [Budapest Technical University]. We established a hybrid computer technology laboratory in which we can conduct the most favorable computerized testing of complex physical processes or dynamic systems (for example, bridge-vehicle systems, nuclear power plants, etc.) The most important tool of the hybrid computer technology laboratory is the ADT 7300 hybrid computer model system. The present article describes the ADT 7300 model system.

Intensive research work on the theme of system simulation has been going on in the Process Control Faculty of the BME since the faculty was formed (1964). We had as our goal the most favorable computerized study of complex physical processes or systems. We developed a number of methods for simulation of various highly complex dynamic systems (flare towers, bridge-vehicle systems, water pipe networks, reactor control systems, etc.) and in many cases we have used them in practice. We developed as an organic part of our research activity on the theme of system simulation a number of simulation devices and equipment for domestic and foreign users. We established the Hybrid Computer Technology Laboratory (HSZL) using domestic modeling devices and import equipment and we have solved a number of practical problems there.

In what follows we will deal with a brief description of the services of an important piece of equipment of the HSZL, the ADT 7300 hybrid system (figure 1), thus aiding even wider efficient use of it. A block diagram of the ADT 7300 hybrid system used in the Process Control Faculty of the BME can be seen in figure 2. The hybrid system consists of two main parts: an ADT 3000 hybrid-analog computer and an ADT 4300 digital process control computer.

Appropriate peripherals and auxiliary equipment (DISK, UV recorder, etc.) belong to both parts.

## ADT 3000 Hybrid-analog Computer

The ADT 3000 hybrid-analog computer is a third-generation computer which in itself makes possible complex scientific-technical computations. The computer has precise, broad-band, analog and digital operating elements and the possibility of easily reviewed programming is ensured in the system. Three ADT 3000 computers can be operated in parallel to do complicated computations. One important part of the ADT 3000 is the hybrid interface, which ensures the possibility of connection with a digital computer.

### Operating Elements of the ADT 3000

#### A. Analog Operating Elements

The analog operating elements of the ADT 3000 work with a reference voltage of plus or minus 10 volts. The linear operating elements have a precision of 0.05 to 0.1 percent; the nonlinear operating elements have a precision of 0.1 to 2 percent, depending on the type of nonlinearity with a band width higher than 100 kHz.

##### 1. Integrator

The integrators, with the analog memory attached to them, have three states and can be controlled in the following operational modes: initial conditions, integration and stop ("hold").

The integrators can be controlled with two logical signals as double or quadruple integrator groups. If we do not use ad hoc logical control, then the entire integrator is controlled automatically by the operational modes of the computer. The time constant of the integrators can be changed with the aid of logical signals in the ratio of 1:1000. In addition the time constant of every integrator can be changed in the ratio of 1:10. If necessary, the integrator can work as a two-state device in the following operational modes: integration and tracking (in memory for setting initial conditions), after which the analog unit can be used freely.

The integrator can also be used as a controllable summator, the inputs of which can be selected by logical signals.

##### 2. Analog Memory Pair

The memory pair consists of direct and inverse memories which are controlled by logical signals so that they can alternately be in the TRACKING-MEMORY auxiliary operational modes. An additional logical signal makes possible quick setting of initial conditions in the course of the computation. This element can be used as an analog memory pair or independent analog memory.

##### 3. Summator, Inverter, Implicator

The summator has 4 inputs which are weighted as follows: 1, 1, 5, 5. The implicator has 3 inputs with weighting coefficients of 1, 1, 5. The number

of impicator and summator inputs can be increased with passive summing circuits having four inputs each.

Due to stability problems, a limiter takes the place of the feedback resistance in the impicator.

#### 4. Coefficient Potentiometers

There are three types of coefficient potmeters in the ADT 3000 hybrid-analog computer:

--manually set potentiometers without output amplification;

--manually set potmeters with output amplification; these can be a) nonsymmetric or b) symmetric feed types; and

--digitally controlled potmeters.

The manually set types are threaded, 10-turn, Aripot 16 types.

The digitally controlled potentiometers are actually 12-bit relay "digital-voltage" (D/A) transformers which can be set by the digital computer or from the keyboard of the operator's console.

The nonlinear elements include a diode multiplier/divider, a fixed diode function transformer, an adjustable diode function transformer and circuits modeling typical nonlinearities.

#### 5. Diode Multiplier/Divider

The point diode quadratic heat-compensated multiplier with permanently connected operations amplifier makes possible 4-quarter multiplication, division in 2 quarters, division in 4 quarters and modeling of  $X^2X/X/$  and  $\sqrt{X/}$  functions.

#### 6. Fixed Diode Function Transformer

The fixed diode function transformer is 10-phase and heat compensated and has its own permanently connected operations amplifier. With the analog part completely built up, the programmer has available a function transformer for the modeling of the following functions:

$\sin x$ -- $\cos x$	in intervals of plus or minus 90 degrees
$\ln x$	in intervals of 1 decade
$x^3$	in intervals of X (0; 1)
$1/x$	in intervals of X (0.1; 1)

#### 7. Adjustable Diode Function Transformer

The adjustable diode function transformer approximates the generated function with a broken line consisting of five linear segments, where the break-points and slope can be set. The function transformer has its own operations

amplifier. If necessary, two-function generators can be connected in series, which makes possible a more precise approximation of the modeled function with more linear segments.

## 8. Typical Nonlinearities

For modeling nonlinear characteristics there are built-in ideal diode circuits, with adjustable breakpoints and a permanently built-in operations amplifier. In addition there are available circuits modeling the summation of absolute values. The inputs and outputs of all typical nonlinearities are led to the exchangeable program table.

### B. Hybrid Elements

The hybrid elements make possible two-way transit with the ADT 3000 hybrid-analog computer between the analog and digital units. These elements are: comparator, electronic switch and functional relay.

#### 1. Electronic Comparator

The electronic comparator has three analog inputs. If the algebraic sum of the input voltage is positive, there is a logical one at the output of the comparator; if it is negative, then there is a logical zero. The desired output can be set with logical signals or manually with the aid of the keyboard (if we want to adjust it to a stable logical level independent of the analog part.)

#### 2. Electronic Analog Switches

The electronic analog switches are of the switchable input-weighting resistance type and can be connected to the null point of any operations amplifier. The switches can be controlled individually with logical signals.

#### 3. Functional Relay

The functional relay has two permanent positions and two switchable contacts which are led to the program table of the computer. They can be controlled individually with logical signals.

### C. Parallel Logical Elements

The logical system of the ADT 3000 hybrid-analog computer contains a set of parallel logical elements which makes possible timing to the analog operations and control of the program by steps. The following programmable elements of parallel logic are available in the ADT 3000 computer:

--two- and four-input NOR/OR and AND/NAND gates with direct and inverse output;

--universal flip-flops;

--controlled flip-flops (both types of flip-flops can be controlled with logical signals or push buttons);

--four-bit shift register with the possibility of sequential stepping;

--a backward counter, a BCD counter with a preset possibility in the 0-159 range, controllable with the digital computer or push buttons;

--logical derivators for deriving upward or downward edges with direct and inverse output;

--monostable flip-flops with direct and inverse output; and

--indicator lamps, which indicate the logical values of the logical computation network at an optional place.

The momentary state of the output of all flip-flops and the momentary state of the BCD counter and logically controlled indicator lamps can be transmitted in the form of 16-bit addressable logical words by group to the digital computer.

#### D. Connection Unit

The connecting electronics (interface) of the ADT 3000 hybrid-analog computer between the analog and digital parts contain the following:

--circuits, which forward addresses from the digital computer to the address register of the ADT 3000;

--16 electronic D/A transformers (12 bit);

--24 relay D/A transformers (12 bit), which can be used as digitally controlled potentiometers and whose analog inputs and outputs are led to the program table;

--circuits for transmitting the 16-bit logical words from the digital computer to the analog computer;

--circuits to set the addressable flip-flops;

--circuits for transmitting the address instructions, which control the operational mode of the analog part;

--circuits to transmit instructions, the logical outputs of which are led to the program table;

--a fast A/D transformer with multiplexer, the 16 addressable inputs of which are led to the program table;

--circuits to transmit the logical word (16 bits) from the analog computer to the digital computer;

--circuits to read the control circuits and logical states of the analog computer;

--three level program interrupt circuits, which serve to create special subprograms for the digital computer;

--a circuit to interrupt the program immediately if the amplifier is overloaded;

--circuits to read the addressable condition word, which make possible transmission of data on the state of the operational mode of the analog computer to the digital computer and which also forward the interrupt conditions of the program of the digital computer.

#### E. Addressing System

The addressing system makes possible automatic and manual control of the ADT 3000 hybrid-analog computer, ensuring the selection of optional computing elements of the main or auxiliary computers (which may be connected to the main computer).

#### F. Programmable Control System

An important part of the ADT 3000 hybrid-analog computer is the programmable control system; the so-called control unit, which makes possible the realization of various control algorithms with automatic control of the analog and logical computational steps in the case of iteration; optimization; and other computations. The control unit contains 12 base blocks, 6 decision blocks and 3 timing blocks.

The base block of the control unit generates 2 sequential time intervals, the so-called preparation and worktime periods, which can be adjusted in the range between 0.1 msec. and 10 sec.

The timing block is a monostable multivibrator controlled by an analog signal to change the analog voltage into a time interval which can be used for control either independently or connected with the base block.

The decision block makes possible the branching of the signals of the several base blocks, depending on logical conditions. With the aid of these blocks it is possible to create the series of time intervals desired by the program and thus to realize directly the desired computation algorithm, including conditional jumps.

In addition the ADT 3000 hybrid-analog computer is equipped with circuits which ensure the controllability of the computer and its units manually with push buttons or automatically with the logical signals of the computing network or the digital computer.

## G. Measurement and Indicator System

The measurement and indicator system ensure the easy and convenient use of the ADT 3000 hybrid-analog computer. The basic structure of the ADT 3000 computer includes:

- an indicating instrument on the control panel;
- a digital measurement system which can be used with an asynchronous, synchronous, repeating and one-time option, according to the choice of the operator, as a precise digital voltmeter or as a decade impulse counter;
- a six-decimal number giving the result of the measurement, including sign;
- an indicator system showing overload of operations amplifiers;
- an indicator system showing the momentary state of comparators, flip-flops, counters and control unit;
- a system for manual setting of digitally controlled potentiometers and D/A transformers, which shows the content of the data register with a four-decimal number; and
- a system for swiftly setting time steps and the initial conditions of the several integrators.

### Basic technical data:

- a. Analog computation elements: 3-state integrators with analog memory, 20; summaters, 12; inverters, 12; implicators, 12; passive summing circuits, 12; memory pairs, 8; diode multiplier/dividers, 8; fixed function transformers, 8; variable function transformers, 8; circuits summing absolute values, 4; ideal diode units, 8; manually set potmeter with nonsymmetric feed, 38; symmetric feed manually set potmeters, 6; digitally controlled potmeters, 24.
- b. Hybrid elements: comparators, 8; electronic switches, 16; logically controlled functional relays, 4.
- c. Logical and digital elements: 4-input OR, 10; 2-input OR, 10; 4-input AND, 30; 2-input AND, 8; controlled flip-flops, 12; universal flip-flops, 4; shift registers (4-bit), 2; BDC counters with preselection (PRESET) with a capacity of 159, 4; logical deriviers, 10; monostable multivibrators, 10; logically controlled switches to the emitter, 10.
- d. Programmable control unit: base blocks, 12; decision blocks, 6; timing blocks, 3.
- e. Connecting electronics (interface): address register (4 octal place values), 1; fast 12-bit D/A transformers, 16; register for D/A logic word

(16-bit), 1; fast A/D transformer with multiplexer (12-bit), 1; number of multiplexer inputs, 16; logical word A/D (16-bit), 1; interrupt system (3-level, programmable), 1.

#### ADT 4300 Digital Computer

The ADT 4300 is a ferrite memory-phase register-controlled third-generation computer with a memory capacity of 32 K 16-bit words. Operations are executed in two accumulators or between them and memory. The accumulators can be accessed by memory address also.

The computer has fixed-point arithmetic logic and shifting instructions, subroutine calling and jumping instructions and conditional instructions.

The memory is organized by cards. The cards are 1 K (1,024 words) in size. The zero and current cards (according to the instruction counter) can be accessed directly; the other cards can be accessed only by indirect address.

The computers' peripherals can be operated by program, with interrupt or with DMA (direct memory access).

The computer has a memory protection option, memory parity check and interrupt feed voltage failure logic.

The ADT peripheral assortment is as follows:

--Real Time clock;

--Disk (KDP 720), 1 fixed, 1 exchangeable disk, 202 bands, 2 disk sides, 12 256-byte sectors;

--Display (VT340), 16 x 80 characters;

--Display (VT52120), 16 x 80 characters;

--Punch tape reader (FS751), 750 characters per second speed;

--Punch tape perforator (DT 105S), 150 characters per second speed;

--Matrix printer (DZM 180), characters consisting of 7 x 7 points;

--Typewriter (Consul 254.8);

--Line printer (VT 27065), 136 positions, 900 lines per minute;

--Graphics device consisting of 2 units--DIGIBAK 512 interpolator and BAK 5T X-Y coordinate graphics; and

--Connecting unit, to the ADT 3000 hybrid-analog computer.

## Operating Principle

The block diagram of the computer can be seen in figure 3. The basic operating unit of the central unit is a phase one. During the period of the phase a memory cycle is completed (if necessary). The phase is divided into eight strokes; during the strokes different operations can be executed. The phases of the computer are the following:

**FETCH:** reads instruction from memory and loads it into instruction register. Every instruction begins with this phase and instructions between registers as well as I/O instructions are completed during this phase.

**INDIRECT:** memory reference instructions, if they contain an indirect address, processing is continued in the indirect phase. The reading in of subsequent members of the indirect address chain takes place in this phase.

**EXECUTE:** executes the operation of the memory reference instructions.

**INTERRUPT:** accepts an interrupt request and determines the address of the next instruction.

**DMA:** a phase used by the two DMA controls carrying out channel functions, during which service to the peripheral connection or data transmission takes place.

## Memory Organization, Addressing

Eleven bits (4 bits of the 16-bit instruction are the instruction code while 1 bit signals indirection) are available to determine the address in the code of the memory reference instructions. Since this does not permit addressing the entire 32 K of memory, the memory is divided into 1-K (1,024-word) cards. Ten bits are needed for addressing within these. According to the 11th bit, the addressed card is the 0 card (words 0-1,023), or the card on which the instruction is located (the current card). Memory words on the other cards can be accessed only by indirect addressing.

The instruction system of the ADT 4300 computer can produce 64 different peripheral addresses, of these the first 8 (0-7) serve to set or check the various special registers of the central unit.

## Operating Systems

### DOS III System

The DOS is a system developed for batch processing, which, however, can be controlled from the operator's console also. The DOS system divides the disk into a number of areas independent of one another. Some of these organize the library while others serve only as work areas. The DOS system is capable of running absolute binary programs, which run above the memory area occupied by the system. The translating programs of the DOS system

produce relocatable binary segments which can be edited to the desired location by the editing program and during editing there is also a way to activate the library segments automatically.

#### The MIDISYSD System

The MIDISYSD system is the interactive operating system of the ADT 4300 digital computer. The system and the programs running under it are memory resident, but it is possible to use disk. The system contains a disk handler which executes the read-write commands.

The MIDISYSD system is a developmental system prepared for assembly language program development, which makes maximal use of the possibilities offered by the VT 340 display. It regards the display screen as a unit on which it displays information intended for the user and from there, with a character command implementing the visible condition, it reads the user's instructions. The user always sees on the display screen the momentary condition of the system or its program and can easily make corrections.

The MIDISYSD system very effectively aids the loading of assembly programs. During the running of the user program or after it is stopped, the content of memory can be examined and modified, the content of memory can be written out and other information appears with address instructions.

The queries of the MIDISYSD system not only take care of the physical handling of the peripherals but also include various read and write subroutines and auxiliary programs necessary for the operation of the system.

#### The HYBAS Language

HYBAS is an interactive language designed for computations on the ADT 7300 hybrid computer. Its primary task is setting the parameters of the hybrid and pure analog programs. It makes possible preparation of the problem and the algebraic computations needed to analyze various differential equation systems and parameters and to determine the maximal value of the parameters, etc.

The basis of the HYBAS language is the BASIC interactive programming language. The hybrid aspects of the HYBAS language make possible convenient programming of static supervision of hybrid and analog tasks in such a way that a large part of the program can be used conveniently to check switching and computation as well.

HYBAS programs can be loaded from the display keyboard or from the punch tape reader.

The basis of the HYBAS language--similar to BASIC--is the instruction line. The HYBAS program language makes possible two fundamental computation modes, the direct and indirect operating modes. If we are working in the direct mode then the instruction line consists of two parts, the line number and the HYBAS instruction.

The HYBAS system reads the instruction thus written, checks it syntactically and stores it if it is correct. In the direct mode the instructions thus stored are executed on the RUN system command. If we want to calculate in the direct mode then the instruction can be written in without a line number. The computer executes instructions thus written in immediately, so we can select the desired mode by numbering the lines (indirect mode) or by leaving out the numbers (direct mode).

Arrived: 7 June 1982.

#### CAPTIONS

Figure 1: Uncaptioned.

Figure 2: The Hybrid System of the BME process control faculty.

Figure 3: Block Diagram of the ADT 4300 Computer.

#### BIBLIOGRAPHY

1. Dr Z. Benyo, Z. Szabo, I. Villanyi: "The ADT 7300 Hybrid Computer System," University Note, Portfolio Number J5-1395.
2. A. Kley: "Hybrid Computers," Technical Publishers, 1972.
3. Dr J. Frank: "Operating Guide for the MEDA 43 HA Hybrid-analog Computer," a publication of the construction machines and material movement machines faculty of the BME, Budapest, 1980.
4. Dr Z. Benyo and I. Villanyi: "The ADT 3000 Analog-hybrid Computer," a publication of the process control faculty of the BME, Budapest, 1980.
5. Z. Benyo: "Development of Hybrid Computer Technology and Its Application Areas," MERES ES AUTOMATIKA, Vol XXIII, No 10.

8984

CSO: 2502/75

ES 1026: FIRST APPROVED MEMBER OF ESR 2/II SERIES

Budapest SZAMITASTECHNIKA in Hungarian May 83 p 6

[Article] by Dr Janos Greiner: "ES 1026: First Approved Member of ESR 2/II Series"

[Text] The ES 1026 computer was developed in Czechoslovakia and approved in November 1982. The basis of the system is an ES 2026 central unit which has 10 times the data-processing capacity--compared with the ES 1020 computer in its category--and consists of a single cabinet.

It can be seen that this modern central unit is characterized already by a great increase in the performance/price technical-economic efficiency index.

According to analyses done in Czechoslovakia, the ES 1026 universal computer meets the many requirements of enterprises and institutions in the broadest sense. Due to its architectural structure and functional characteristics it is a very usable system with 512 K bytes of semiconductor operational memory and background memory which can be expanded to 1,000 M bytes, making it suitable for practically all data-processing, technical-scientific, on-line process control and other tasks.

The following ensure the high reliability and broad utility of the computer:

- highly integrated and reliable parts;
- great system security as a result of automatic handling of possible failures or errors;
- large-capacity operational storage, up to 16-M-bytes storage capacity with virtual memory technique;
- parallel processing, ensuring broad-scale data transmission in the central unit;
- large-capacity disk storage (to realize large data bases and large integrated systems);
- communications module, to set up remote data-processing systems as needed;

--little space requirement as a result of modern logical construction, use of highly integrated elements and a high degree of efficient packing;

--assurance of additional important functions of the modern computer generation (standard instruction set for complete software compatibility, a standard interface system for connection to ESR-1 and ESR-2 peripherals, for putting together optional, user-oriented, remote data-processing and computer systems, etc.)

#### The ES 2026 Central Unit

The central unit--as can be seen in the diagram--is based on the building block idea and consists of six relatively independent microprogram-controlled modules, one double operational store module and a central control module. Every microprogram-controlled module has an independent-control instruction memory.

Within the central unit a triple-bus system takes care of communication among modules, signal transmissions of the central control module and signal transmission toward the service module.

The main technical data for the central unit are: number of instructions, 17 per second; operating speed, SCIENTIFIC MIX GIBSON III E, 78,000 operations per second, COMPUTER MIX, 103,000 operations per second; operational store, capacity, 256-512 K bytes; query breadth, 72 bits; number of channels, 4; transmission capacity, 1,032 K bytes per second.

#### Operation-completing Module

This is a microprogram-controlled module which serves basically to process instructions. These can be: control, general, decimal, floating-point and I/O [input/output] instructions. Its processing breadth is two bytes. The module consists of 3 main parts: microprogram storage (16 K half-words), counter (128 + 4 half-words) and internal adapter.

The instruction execution time data for the operations module are: fixed-point addition and subtraction, 5.8 microseconds; floating-point addition and subtraction, 40-44 microseconds; double-precision floating-point addition and subtraction, 44-49 microseconds; fixed-point multiplication, 22-26 microseconds; floating-point multiplication, 49-55 microseconds; double-precision floating-point multiplication, 180-185 microseconds; fixed-point division, 64-68 microseconds; floating-point division, 66-70 microseconds; double-precision floating-point division, 202-208 microseconds; transfer of control, 2-4 microseconds; and short operations, 6-10 microseconds.

#### Operational Store Module

The standard blocks of the store contain semiconductor elements with a total storage capacity of 256 K bytes. Two such operational store modules can be placed in the cabinet of the central unit. Thus the maximum operational store capacity is 512 K bytes. Word length is 8 + 1 bytes and memory

organization is 16 K x 72 bits. Access/reading time--including checking--is 625 nanoseconds. Writing time is 750 nanoseconds. The ECC is 8/8 bytes per correction bits.

#### Operator and Service Module

The operator and service module placed in the central unit of the computer is microprogram controlled. It consists of a service processor and several special adapters. On the one hand these provide internal communication and on the other hand they make possible the connection of the following service units to the module: service screen, service keyboard, service mosaic printer, operator field and floppy-disk storage.

#### Central Control Module

Its chief task is organization of internal connections between the modules of the computer and data transmission. It provides control and protection of the operational store modules and generates the parity bits. It checks and corrects data read from main storage. (It corrects every "one-bit error" and reliably recognizes all "two-bit errors" and some "three-bit errors.") It reports to the service module--as do the other modules--failure and error conditions. Functionally the central control module is divided into two parts--the operational store control block, of which the check and correction unit is an essential part, and the control block for connections among modules, which also has a priority comparison unit.

#### Disk Control Module

The integrated-disk control module is microprogram controlled and can service 4 disk storage units with 100-M-byte-capacity, exchangeable disk packs--and every other ESR disk storage unit. On the one hand this module carries out functions corresponding to the activity of the selector channel or block multiplex channel and on the other hand it services the disk storage unit--running operations--positioning during read-and-write operations, etc. On the other hand this solution results in significant savings (and by reducing its size the independent control unit cabinets become superfluous), and on the other hand the possibilities become much more favorable for direct cooperation with other computers and for error delimitation, error recognition and error correction.

The maximum disk storage units which can be connected to the disk module interface are: 4 units of 100 M bytes each or of 2 x 100 M bytes each; 8 units of 29 M bytes each; and 4 units of 7.25 M bytes each.

The maximum data transmission capacity of the disk control module is 806 K bytes per second.

#### Tape Control Module

The integrated tape control module is microprogram controlled and supplies the functions of selector channel and a magnetic tape storage control unit. In

accordance with this, it consists of an internal adapter connected to the bus system, a microprogram-controlled processor and an external adapter--all serving to connect the module to the magnetic tape stores. Due to significant size reduction, the independent control unit cabinets became superfluous here also. The operations module controls the work of the tape module. One can connect a maximum of eight magnetic-tape storage units to the tape module interface. The maximum data transmission capacity of the module is 126 K bytes per second.

#### Multiplex Module

Relatively slow peripherals can be connected via a standard I/O interface with the microprogram-controlled multiplex module. The module has 32 subchannels; there is a possibility for parallel operation. The multiplex module provides 2 operational modes--a byte multiplex mode (24 K bytes per second) and a monopole mode (50 K bytes per second).

The 32 subchannels can provide 8-byte multiplex operations for 16 pieces of equipment each, connecting a maximum of 128 peripherals.

#### Communication Module

The microprogram-controlled communications module provides the possibility of remote processing. With its help the ES 1026 can be connected with distant remote data-processing equipment or other computers.

From the computer side the communications module corresponds to a byte multiplex channel with 16 subchannels. In accordance with this it makes possible standard connections for a maximum of 16 synchronous communications cables. Naturally, there must be a modem for each of the connected communications cables. The system makes possible the connection of remote data-processing stations in both the point-to-point mode and the multipoint mode. The transmission system operates synchronously on all cables; the information exchange algorithm is BSC Binary Synchronous Communications<sup>7</sup>. The information code is KOI-7. The data transmission capacity of the communications module is 50 K bytes per second.

#### ES 1026 Software

##### System Software

The ES 1026 computer is delivered with the ESR DOS/VS (DOS-3 version) virtual operating system, with which the operation of the computer is most efficient. But it also works perfectly with the IBM DOS/VS (DOS-34 version) system, which can be leased.

The ESR DOS/VS has the following interpreter programs: Assembler, COBOL, FORTRAN IV, RPG 11, PL/1, PL/S, SISTRAN, Pascal and SIMSCRIPT. The operating system is provided with a very developed diagnostic system, the POWER system, and program loading, editing, archival and other programs. Among the latter

one can find: DL/1 data base language, GEPAS data-processing program generator, SORT program generator, converter program, data transmission programs, etc.

### Applications Software

As a result of software compatibility one can run on the ES 1026 computer all applications software under ESR DOS, ESR DOS/VS, IBM DOS and IBM DOS/VS up to the largest integrated applications systems including data base management systems. Guaranteed software supply for the ES 1026 computer is based primarily on the already significant common-software base of the socialist countries and their other software tools.

### Block Diagram of the ES 1026 System

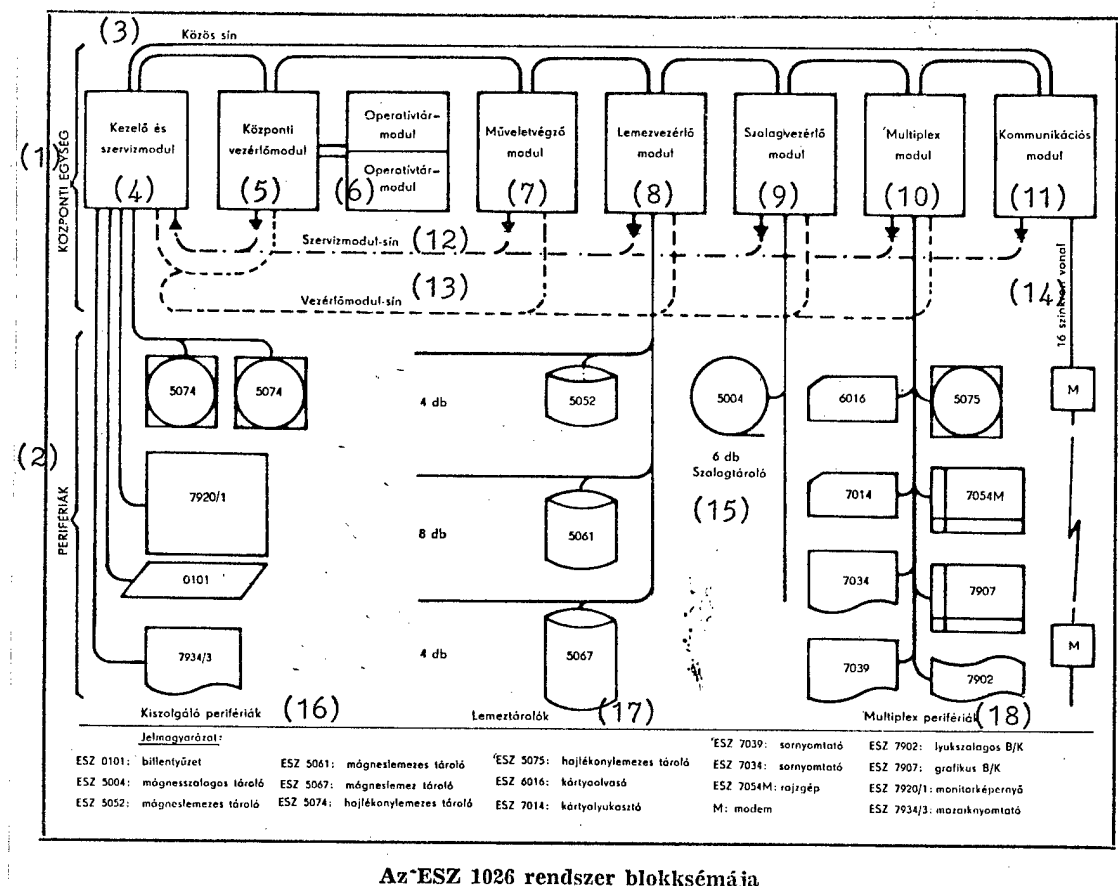

Az ESZ 1026 rendszer bloksémája

(Key on following page)

Key:

1. Central unit
2. Peripherals
3. Common bar
4. Operator and Service module
5. Central control module
6. Operational store module.
7. Operation completing module
8. Disk control module
9. Tape control module

10. Multiplex module
11. Communication module
12. Service module bus
13. Control module bus
14. 16 synchronous lines
15. 6 tape stores
16. Service peripherals
17. Disk stores
18. Multiplex peripherals

ESZ 0101: Keyboard  
ESZ 5004: Magnetic tape store  
ESZ 5052: Magnetic disk store  
ESZ 5061: Magnetic disk store  
ESZ 5067: Magnetic disk store  
ESZ 5075: Floppy disk store  
ESZ 5075: Floppy disk store  
ESZ 6016: Card reader  
ESZ 7014: Card punch

ESZ 7039: Line printer  
ESZ 7034: Line printer  
ESZ 7054M: Graphic machine  
M: Modem  
ESZ 7902: Punch tape I/O  
ESZ 7907: Graphic I/O  
ESZ 7920/1: Monitor screen  
ESZ 7934/3: Mosaic printer

8984

CSO: 2502/56

SCI-L: NEW SYSTEMS COMPUTER INFORMATION LAB

Budapest SZAMITASTECHNIKA in Hungarian May 83 p 5

Interview with Pal Nemeth, deputy director of SZKI (Computer Technology Coordination Institute), by Margit Takacs

Text At exhibits and in prospectuses describing products, you have surely met several times already with a new name, Sci-L (Systems Computer Informational Laboratory), a Computer Technology Informatics Development Subsidiary founded last year by the Computer Technology Coordination Institute. We asked Pal Nemeth, deputy director of SZKI, about its activities and plans.

Question What was the goal of your institute in forming the subsidiary and what tasks are the workers of the new unit getting?

Answer In 1982 SZKI switched to a new developmental strategy and a new market policy. We changed many things in our earlier practice, when in general we undertook research on a theme or on the development of a product on the basis of commissions. Even then we worked with highly productive methods, with highly automated, computer-aided design, and we produced good equipment, generally in a short time, and we also prepared for its application.

Last year, in order to better adapt to the swiftly changing economic conditions and building on our existing high-level technology, we switched to a new "thought mode"--we will not work on the basis of commissions but rather, watching and taking into consideration the international and domestic market conditions, we will decide what products and "turnkey" systems we will develop. We are striving for applications useful and economical at the national economic level and we would like to move "ahead of the market" with initiatives which take a rational degree of risk.

We also had to change the structure of the enterprise to realize the new ideas. We needed an organization dealing with expressly engineering-marketing activity--which not only "reads and hears" about the market but rather is present everywhere--is in constant contact with customers and is interested in them and talks with them, that is, is providing research and development with the credible and indispensable information derived from their theoretical and practical activity. Within SZKI we are organizing the

production and large-series manufacture of developed products, mobilizing a number of manufacturing plants at once, bringing together various firms and various capacities, developing various configurations, dealing with service, software followup, customer service and instruction and giving applications development advice to users, and all this in the interest of having the application of computer technology be more and more effective at the given enterprise in the given area.

In regard to export, this means doing market research, ensuring a constant presence abroad.

Since it is difficult for a research and development organization to undertake this kind of work, we found it most suitable to form a subsidiary to carry out the new tasks.

Question How did the workers at the institute accept this new "enterprise"? Were the research and development experts happy to undertake work deviating from what they had been doing, which also requires market and commercial information?

Answer There was a little fear and reservation in accepting it at first, but many felt and still feel that they might show up better in this market-oriented work. Today our best workers are applying for work at the subsidiary. A transfer represents no special difficulty; a person who worked as a designer thus far can get into service and customer service work; they can talk to the manufacturers easily, for they are well acquainted with the equipment designed by them. It is our experience that those giving good performance thus far can be encouraged to very good performance by this form of work.

People usually identify with good and clever changes; solving the new tasks mobilizes their imagination, liberates dormant energies in them. In any case, in our institute we always tried to have people develop their talents; in the course of years past we raised a staff of experts here who always answered yes if asked if they were willing to undertake more. So we only had to convince the "nucleus," the first few people, and the rest gladly undertook it on their own. At present 50 people are working in the subsidiary enterprise, but by the end of the year they will number about 100.

Question In recent months SZKI has won market and professional success with several of its products; I am thinking here primarily of the MO8X professional personal computer, already operating in many places, and the matrix printer prepared for microcomputers. Did the Sci-L manage these already?

Answer Yes. The initiation of the project aimed at developing a personal computer with a newly created developmental group at the beginning of 1982 virtually coincided with the formation of the subsidiary. Since we financed this project from our circulating funds, some of the costs had to be paid off in the first year. We got the machine in production in 8 months; indeed, we sold the first few within this time. We organized the necessary cooperation, prepared the manufacturing documentation and created our own service base. The

MO8X equipment itself is only the "tip of the iceberg." Using it requires framework systems, operating systems and a suitable software development technology plus documentation, instruction, software followup and advice on the best possible use of the computer. The purchaser expects swift installation and usable handbooks, and they will get them from us. It was our goal to produce a relatively cheap, multi-use, easily maintained, user-friendly professional personal computer. We feel that the MO8X machines with their purchasing price of 400,000-500,000 forints represent device acquisition based on the investment realities. We would like to increase the number of users significantly with the purchase and use of them. It would be good if they were to go places where the computer has not been a working tool up to now.

Question I believe that a good many more would like to buy such a machine than you are able to manufacture. Where will the turnkey systems go; what areas of the economy are you watching especially?

Answer Last year we sold 30 of the MO8X computers; in the first quarter of this year we sold another 50; by the end of the first half-year we will have sold another 100. The trend--as I think you can see--is rising strongly.

Interest is about four of five times greater than the number of machines we can sell. Those who want one with existing applications software may get it in the 4th quarter; we are giving preferred treatment to those who undertake to develop software for their own special area.

Thus, for example, we made a machine available for use by the Engineering School of the Technical University so that they could prepare special software for construction planning. SZKI will have prepurchase rights on these program products.

We regard agriculture and the foodstuffs industry, energy management, freight transportation, warehouse inventory management, trade and support for engineering-mathematical computing and engineer design as applications areas to be stressed. But we are also dealing with networks which can be realized with personal computers, not only local networks but long-distance ones also.

In addition we have developed in-house teledata systems based on ESR computers and personal computers. We prepared two sample systems for the Agricultural Machine Manufacturing Enterprise in Hodmezovasarhely and for the Borsod Coal Mines.

We have prepared applications software for our personal computers so there will be no need for ad hoc program development; many of the applications can be covered with "ready-made" or "half-ready made" program products. I must note here that the Hungarian market was hardly ready to accept the fact that 50 percent of the price of a system was hardware and 50 percent was software. Nevertheless we are striving to have more and more software sales follow the sale of the hardware.

We do not want our machines to be "decorations" but rather we want them to be used effectively, in many ways, so that they can be used to solve tasks aiding production work.

Question The development of the microprinter evoked a great response among professionals; there is known to be a great demand for it. How long have you been working on this microperipheral, and when will people be able to buy it?

Answer We started development of the matrix printer in August 1982, jointly with experts from MOM Hungarian Optical Works. We studied a number of foreign printers, asking what ours should be like. The parameters of the product prepared are most similar to the Japanese C ITOH equipment. The technology and design correspond in every respect to the existing manufacturing environment and conditions at MOM. An experimental model was finished at the end of last year and five prototypes were completed by the end of March this year. The Quality Control Institute has done the testing, so series manufacture and sales can begin barely half a year after beginning development.

At present the import ratio of the printer is 25 percent, but we are working constantly on replacing the capitalist parts. The name of the matrix printer is MP80 SZKI-MOM, its printing speed is 70 characters per second and its printing breadth is 80 characters per line. It contains the entire Hungarian character set, so it can print accented letters too! By the end of next year we expect to have made 3,000-3,500 of them; SZKI has signed a purchase contract for the first 1,000 of these. The price will be around 60,000-80,000 forints.

Question What new things will appear in the near future?

Answer At the spring Budapest International Fair we are giving a cross section of our new type of activity. Together with the devices exhibited we will present the computer technology and service background also. Thus we will operate the personal computers in various types of networks and with new-type peripherals. We have built in new devices to reduce costs, such as a conductive rubber-touch keyboard, the price of which is one-third that of the traditional keyboard.

The M08X is only the starting point in the development of our professional personal computers based on an entirely new design. At the spring Budapest International Fair you will see the next member of the faculty, a 16-bit personal computer.

Question SZKI--not being an enterprise set up for manufacturing--works together with many cooperating partners. What sort of experience have you had concerning this cooperation?

Answer The success of cooperation depends on what sort of partners get together and how they treat each other. If we formulate precisely what we want and document it, that is, if we are demanding of ourselves in regard to

technical preparedness and discipline, then we can expect and we get the same from the partner undertaking cooperation with us.

The Computer Technology Experimental Installation Association (SZKUBT), for example, which was created by KFKI [Central Physics Research Institute], Videoton and SZKI, produces small-series and zero-series equipment with the most developed technology.

We have had good contacts with MOM for a decade also, we get floppy disks from them and the matrix printer is our joint achievement. Orion provides picture-tube displays and keyboards for our personal computers.

[Question] At the beginning of our talk you mentioned guidance of export activity as a task of the subsidiary enterprise also. In conclusion, could you tell us what countries it has contact with and what products it offers?

[Answer] Our export makes up 25-30 percent of the production value of the institute. The FRG, Austria, Sweden and France are among our most significant partners. Last year we also signed a commission agreement with a Canadian firm for the sale of our software products and technology throughout North America. Our PROLOG language systems and the SO-MI-KA program to test the quality of software products enjoy the greatest popularity abroad. Our contacts with Japan are good also; we will prepare the installation of several PROLOG systems for computers working in Japan, joining the fifth-generation project.

8984

CSO: 2502/56

## ISKRA-226 SMALL COMPUTER

Budapest SZAMITASTECHNIKA in Hungarian May 83 p 7

[Text] For 3 days at the beginning of March the professional public could get acquainted at the SZAMALK [Computer Technology Applications Enterprise] with the newest Soviet small computer, the ISKRA-226, just in from the Kursk computer factory.

In regard to its capacity it is between the microcomputers and the minicomputers. A richer array of peripherals distinguishes it from the microcomputers.

The machine shown at the SZAMALK had connected to it a Robotron 1154 matrix printer, an N-306 Soviet graphics device of the A/4 size, a Soviet floppy disk unit containing ES 5074 Bulgarian drives (twin, single side, single-density writing), an IZOT 1370 cassette disk unit (fixed and exchangeable) and an SM 5300.01 Bulgarian magnetic tape unit. It is different from minicomputers in several respects, the most fundamental being that its operational memory and peripheral assortment are smaller and it does not require air conditioning.

The IZOT 226 [as published] is intended primarily for users without prior computer technology training. Its operation can be mastered quickly, the peripherals available make possible the execution of a significant part of the processing in an autonomous mode in the conversational form and if need be it can also be used as a terminal for ESR or MSR computers.

The ISKRA-226 is actually a picture screen display (with character depiction of 24 by 80 and raster resolution of 256 by 560 points) which contains a maximum of 64 K bytes of operational storage, 2 microprocessors (1 to do the processing and the other to control the peripherals), a maximum of 7 sockets and a movable keyboard. Two basic versions are being prepared, the difference being the existence or absence of an ISKRA 005-33 cassette magnetic tape unit (80-K-byte capacity with a transmission speed of 200 bytes per second) built into the front panel. There are 2 versions of microprogram storage, a 48-K-byte BASIC interpreter program or, in the event of programming languages to be loaded in the operational memory, a 16-K-byte read-only memory for the loading program.

The small computer can contain the following for a maximum of 7 at 1 time: a matrix printer connection (Robotron 1154 or 1156 or DZM-180); a graphics device connection (N-306); a floppy disk unit connection (ES 5074); a cassette disk unit connection (IZOT 1370); a magnetic tape unit connection (SM 5300.01 or IZOT 5003); a digital-analog transformer (transformation time 20-100 microseconds); an analog-digital transformer (transformation time 22-mircroseconds, number of channels 32/16); a measuring instrument connection corresponding to the IEEE-448 standard (a maximum of 15 instruments with a maximum transmission speed of 25 K bytes per second); a connection to MSR series computers (SM-3 or SM-4); and a connection to ESR or MSR series computers (with exchangable data transmission protocols, basically the ESR AP-70 terminal protocol).

In regard to program languages, so far one can use only the BASIC interpreter program version corresponding to the WANG 2200, which is also the operating system. Adaptation of an Assembly-level language and of Pascal are under way.

Several graphics programs were shown. The game programs had the greatest success. Users with experience on a WANG operated the computer especially easily.

Price discussions are still under way. Those interested can learn more about price and delivery times at the spring Budapest International Fair.

8984

CSO: 2502/56

PROGRAM FOR COMPUTERIZATION TO BE MADE MORE COMPREHENSIVE

Budapest SZAMITASTECHNIKA in Hungarian Jun 83 pp 1-2

[Unsigned article: "The Status and Future of Computer Technology Applications in Hungary; National Conference, Budapest, 17-18 May"]

[Text] The conference organized by the Computer Technology Applications Enterprise (SZAMALK) in the Congress Hall was opened by Dr Mrs Ferenc Nyitrai, president of the Central Statistics Office, before about 200 invited participants. The application of computer technology, in the words of the introduction, is built into economic processes, has become an organic part of planning and research and is playing an ever greater role in education. For this reason the further development of computer applications and their spread to all areas of the economy are of stressed significance in the Hungarian national economy.

A turning point in the application of computer technology took place at the beginning of the 1980s; an intensive phase replaced the phase of extensive development. The goal of the conference is to report on the achievements and define the most important tasks of the future.

Speech by Dr Lajos Faluvegi

The deputy chairman of the Council of Ministers and president of the National Plan Office pointed to the economic strategy significance of computer technology and microelectronics, which is why special attention is devoted to them in long-range and medium-range planning work. Electronicization and the spread of computer technology lead to the accumulation of complex devices and knowledge which, creating a qualitatively new situation, result in information becoming a productive force. It must be recognized that the new, mutually interdependent achievements of microelectronics, automation, computer technology, communications and mass communications have a determining effect on the material and intellectual capacity and economic strength of the country.

In industrially developed countries one can well observe the effect which the massive spread and economic structure of computer technology are having on the

ratios of the three basic economic sectors. A substantial part of the labor force is flowing into the so-called information branches even within what are already the service branches. In the United States, for example, 46 percent of the gross domestic product derived, in 1977 already, from activities the essential part of which was the production, processing, preservation, use and spread of information in the comprehensive sense (information and knowledge), including scientific research, education, library matters, the press, television and radio.

This structural change is mutually interdependent with productivity, work culture, social organization and the efficiency of the economy. In the socialist countries these effects can be realized and are being realized within the framework of a planned economy according to the requirements of proportional development. The conference provides an opportunity for us to review and debate our chief tasks and the conditions for their realization --while preparing a new, comprehensive government program. A very important motif of this work is that we recognize and make society aware of the fact that the spread of electronics and the mass spread of the use of computer technology are preconditions for intensive economic development.

By evaluating the experiences in execution of the Computer Technology Central Development Program (SZKFP) adopted in 1971, it can be established that the technical and intellectual foundations for the use of computer technology have developed in many areas of economic life--in the spheres of production and trade alike--and that realistic conditions for applications have been sketched out. By the end of last year the gross value of computer technology devices used in the Hungarian economy reached 21.5 billion forints and domestic industry had delivered about 40 percent of these devices. Significant intellectual property has been amassed in the programs for applications systems and the creation of the Computer Technology Applications Development Fund (SZAFÁ) had an important role in this.

Studying our achievements and problems in the light of international trends, it can be established that computer technology has developed significantly in our homeland and today it stands before a qualitative change. Computer technology, together with other modern informatics technologies, can be used extensively and will finally result in the socialization of this new technology.

On the basis of a proposal by the State Plan Committee the government recently passed a resolution concerning a transformation of the SZKFP in order to accelerate development. According to the resolution, the emphasis in state economic organizing activity must be placed on coordination of the conditions for computer technology solutions and applications. One of the requirements made of the program is that it embrace in a system the production of computer technology hardware and software tools, their use, the research and development needed for this, general and professional education, international cooperation and the link with boundary areas, primarily automation, the wide use of microprocessors and communications. In the course of working out the program, a study must be made to see if it is necessary, and if so with what conditions, to create a comprehensive social-economic program for the 7th

5-year Plan period which will include plans pertaining to the manufacture and use of electronic devices and the development of informatics and telecommunications technology.

In the phase of the socialization of computerization we must reckon with the social environment as an important condition for development. Developing a computer technology attitude represents a qualitative turn in our world picture, in our decision making and in the organization of our everyday life. This attitude can be formed most definitely in education so in the future our educational system must become a much more productive source for the computer technology-informatics culture.

Production culture, organization and the quality of life in general continue to be very important elements in the social conditions system. Only by raising these to a higher level can we imagine an environment favorably receptive to general technical development. The development and use of computer technology must serve meaningful work and the material and spiritual enrichment of society.

Computer technology is not a cure-all, the speaker said in conclusion, but it is certain that it creates a totally new realm of thought. It discloses new possibilities the cultivation of which is indispensable in that developmental phase in which our homeland can enter the ranks of developed countries.

#### Computer Technology Use in the Economy

Three speeches were given on this theme. The first was given by Istvan Banyai, a main department chief in the Hungarian Electric Works Trust, with the title "Computer Technology Use in the System of Hungarian Electric Energetics." The second was given by Ferenc Kiss, a main department chief in the Videoton Electronics Enterprise, with the title "Development of a Complex Information System for Videoton with Modern Computer Technology Methods." And the third was given by Istvan Helybely, a department chief in the Babolna Agricultural Combine, with the title "Computer Technology as a Tool for Increasing the Efficiency of Agricultural Production." The speakers reported on experiences in areas which are of key importance not only from the viewpoint of computer technology but also from the viewpoint of the entire economy, so their achievements might serve as examples for others also.

In the electric power industry, where 2.4 percent of those employed in Hungarian industry as a whole produce 4 percent of the production value of industry, computer technology use is directed at three main areas--process guidance and control, technical-economic guidance and technical-scientific and planning tasks. The gross value of the computer technology devices of the Trust reached 1 billion forints in 1982--as the result of a program under way for 10 years--and the value of applications programs exceeded 130 million. Subsequent studies aimed at an evaluation of the economy of the computer technology installations of recent years justified the preliminary estimates in the 2 most significant applications areas and the investments paid off in 1.5 to 3.2 years.

In 1982 the receipts of Videoton, employing 18,000 persons, exceeded 10 billion forints, and about two-thirds of this derived from export. It is characteristic of their information system, developed as a result of developmental work going on for 20 years, that the entire system now embraces 1,020 programs. The total extent of these comes to 300,000 program lines, the basic data store handled contains 3,100,000 records and the number of monthly transactions averages 380,000 records. The information system offers many-sided support to the planning, guiding and supervising functions of the enterprise leadership. Its utility and effectiveness have been proven unambiguously and well-paced production is being realized at a higher management level. They achieved a saving of about 300,000 norm hours with the series-forming method used in the plants producing parts; the reduction in variety carried out with the aid of the operational technical data base reduced the number of commercial materials purchased from 180,000 to 140,000; the efficiency of stockpile management improved by 21 percent during the 5th 5-Year Plan in terms of stockpiles purchased; and the number of persons employed in the area of costs management (accounting, finances, wages) is unchanged since 1975.

The Babolna Agricultural Combine is one of the largest agricultural operations in the country. In 1982 its nearly 6,000 workers produced a production value of more than 7 billion forints. The enterprise is split up geographically into isolated parts too; its basic organizational unit is the self-accounting operation, the number of which is now 153. Every operation prepares an annual schedule showing the full range of achievement and production value. Supervision and guidance of production are based on a time-proportional monthly comparison of the annual plan figures and actual figures.

Efficient operation of the combine can no longer be imagined without a computer. The Babolna Computerized Guidance System, created by developmental work going on for 7 years, consists of information processing, decision preparation and technical service subsystems, the functioning of which can be felt in a number of respects. With the aid of a computer this gigantic enterprise can be guided sensitively despite its geographic spread and many-sided activities. It was possible to develop an incentive, internal-control mechanism which increased production and productivity on the basis of material interest, but individual work, performance and incentive can be quantified also. Thus the individual, the human being, gets a new role in the collective, greater and more important than before, which liberates surprisingly new energies to increase efficiency. Babolna wants to use this effect not only in production but also, to a maximum extent, in the further development of computer technology.

#### Computer Technology Use in Economic Planning

In his speech entitled "Use of Modern Mathematical, Computer Technology Methods in Economic Planning" Dr Tamas Morva, director of the Planned Economy Institute of the National Plan Office, dealt with questions of the close mutual effect which has developed over the last 20-25 years between economic planning and computer technology. The system of complex economic planning is computer technology oriented in two directions. In the first

place storing and moving the gigantic volume of extraordinarily intricately linked information is possible only with the aid of modern information technology. In the second place the solution of various mathematical models (largely programming models) and the computerization of the operations connected with them have come up at certain junctions of the data net stretched between goals and resources. A swifter introduction of computer technology and a broader spread of its use are organic parts of the program for the further development of the planning system. The mathematical-economic models to be used have a key role from the viewpoint of computer technology applications.

#### Computer Technology Use in Science and Education

In his speech entitled "Computer Technology and Fundamental Trends of our Technical Development," Academician Tibor Vamos, director of the Computer Technology and Automation Research Institute of the Hungarian Academy of Sciences, spoke of the role, possibilities and tasks of domestic computer technology research. Our homeland--simply because of its size--cannot assume a pioneering role, must adhere strictly to world trends and to the international agreements moving toward standards and must create systems which satisfy our own needs. Hungarian research and development must go beyond "fabricating" solutions protected like a hothouse culture by ad hoc measures and customs borders, which are uneconomical and are accompanied by the production of unreplicable products in both hardware and software. Our computer technology institutions must become more cooperative, creating thereby a background for the further development and socialization of computer technology and contributing at the same time to creating the technical conditions for a more substantial and more democratic society.

In his speech entitled "Computer Technology as a Subject and Tool for Education," Academician Sandor Csibi, director of the Signal Technology Electronics Institute of the Budapest Technical University, described the computer technology education conception and the computer technology tools of the institutional education system realized in electrical engineer training.

After the speeches, Dr Mrs Ferenc Nyitrai ended the conference with a few observations. The use of computer technology, she said, demands a high level of organization, the realization of which proceeds with difficulty in our homeland. The further development of the internal guidance systems of large industrial enterprises and large agricultural operations cannot be imagined without highly cultured use of computer technology, and although our material possibilities are limited progress is possible with a suitable coordination of forces and by increasing the level of organization. The conference has shown that we have a functioning staff of experts which--on the basis of their expertise--could work more effectively than at present. Our personnel conditions are better than our achievements, and this derives from the fact that our institutions cannot make use of our intellectual capacity in as coordinated a way as in other countries--not much more developed than we.

The conference has shown that the government and the experts think together in these questions, their opinions are the same, and an important step has been taken not only with regard to evaluating the situation which has developed but also with regard to outlining our own tasks and the path of the future.

(All the speeches at the conference will appear in the near future in a special publication.--The Editors.)

8984

CSO: 2502/54

HUNGARY

CATALOGUE OF 1981 COMPUTER PROGRAMS

Budapest HIRADASTECHNIKA in Hungarian No 6, 1983 pp 261-264

[Article by Dr Karoly Geher, Signal Technology Electronics Institute of the Budapest Technical University: "Catalogue of Computer Programs, 1981."

[Text] The following compilation contains a catalogue of computer programs prepared in 1981 which pertain to electronics. The data on the programs were sent by the responsible leaders of the institutions at the request of the Signal Technology Electronics Institute of the Budapest Technical University.

In accordance with developed practice we have compiled the programs pertaining to electronic devices, electronic circuits, signal technology equipment and signal technology systems. The program catalogue publishes the programs in the order of their arrival.

Name: TRANZ-TRAN POSZT-PROCESSZOR. Content: Documenting and graphic display of the results of circuit simulation. Programming language: FORTRAN. Programmers: Dr Mrs Vladimir Kerecsen Szekelly and Dr Marta Rencz, BME [Budapest Technical University] Electronic Devices Faculty. Proprietary institution and expert: Microelectronics Research Institute of the KFKI [Central Physics Research Institute]; Dr Andras Javor. Date of preparation of report: MERES ES AUTOMATIKA, No 12, 1981 pp 465-468.

Name: LOBSTER PRE-PROCESSZOR. Content: Automatic parameter identification for the LOBSTER logical simulation program. Programming language: FORTRAN. Programmers: Dr Mrs Vladimir Kerecsen Szekely, Dr Marta Rencz, Miklos Pekari and Zoltan Urban, BME Electronic Devices Faculty. Proprietary institution and expert: Microelectronics Research Institute of the KFKI; Dr Andras Javor. Date of preparation of report: MERES ES AUTOMATIKA, No 12, 1981, pp 465-468.

Name: MICAD-1. Content: The program system provides computer-aided design (CAD) for all phases of design of large-scale integrated microelectronic

---

The article reached the editors on 30 March 1982 but can be published only now because of the load of material.

devices (LSI/VLSI). The LOBSTER subsystem performs digital logical simulation studies. The DOLPHIN subsystem makes possible mask lay-out design, interactive cell editing, design rule supervision and combined pattern generator and step and repeat camera control for fragmented mask preparation. The STEP program serves the purpose of technological modeling. Programming language: FORTRAN IV. Programmer: The KFKI-MKI Computerized Design Department and the BME Electronic Devices Faculty. Proprietary institution: META [Hungarian Academy of Sciences] KFKI. Date of preparation of report: Users' handbooks.

Name: C-FFT fokal. Content: The program performs quick Fourier transformations of complex functions known in 1,024 equidistant points. It can be run on a TPA [stored program data processing] or PDP-8 machine with 16 K memory equipped with a fast arithmetic unit. The time range for the transformation is 4 seconds. Programming language: SLANG. Programmers: Istvan Pocsik and Gyorgy Meszaros, MTA KFKI SZFK. Proprietary institution and expert: The Solid Body Physics Research Institute of [SZFKI] of the MTA-KFKI; Istvan Pocsik and Gyorgy Meszaros. Date of preparation of report: KFKI preprint, 1978-1979; obtainable from the KFKI library or the authors.

Name: GRAF. Content: Following the entire path of a guided graph, indicating terminal points in loops and calculating the "length" of the path (from values set to the edges). Programming language: CDC 3300 SIMULA. Programmers: Gyula Csaszar and Tamas Szadeczky-Kardos, BHG FZ [Beloianisz Telecommunications Factory, Development Institute]. Proprietary institution and expert: BHG FI; Gyula Csaszar and Tamas Szadeczky-Kardos.

Name: NEGYFOK. Content: Calculation of the loss probability of a four-degree connection field when there is an Erlang distribution in the first and fourth cross sections and a Bernoulli distribution in the intermediate ones. The load of the several cross-sections can be given independent of one another. Programming language: CDC 3300 SIMULA. Programmer: Mrs Ferenc Szentirmai, BHG FI. Proprietary institution and expert: BHG FI; Margit Agosthazi. Date of preparation of report: User's description, 1982.

Name: FROB. Content: A simulation program for the study of the effect of repeated telephone calls, for a one-degree loss system in the event of traffic branching in two directions, with a 3-3 persistence function depending on cause of error per process and with an interruption time distribution. Programming language: CDC 3300 SIMULA. Programmer: Mrs Ferenc Szentirmai, BHG FI. Proprietary institution and expert: BHG FI; Mrs Laszlo Konkoly. Date of preparation of report: User's description, 1982.

Name: IT2F. Content: A calculation procedure based on an iterative solution of a state equation system for the study of the effect of repeated calls, for a one-degree loss system in the event of traffic branching in two directions. It contains 2-2 persistence values and 1-1 repeat intensities per process. Programming language: CDC 3300 SIMULA. Programmer: Mrs Laszlo Konkoly, BHG FI. Proprietary institution and expert: BHG FI; Mrs Laszlo Konkoly.

Name: SICTI. Content: The program searches for the junctions to be connected to ground (or guard point) in in-circuit measurements of elements of a network consisting of R, C and L elements. Programming language: R12 FORTRAN. Programmer: Dr Miklos Herendi, MIKI [Instrument Industry Research Institute]. Proprietary institution and expert: MIKI; Dr Miklos Herendi. Date of preparation of report: Research report, December 1981.

Name: BAHAMA. Content: To study the life expectancy and economical characteristics of the trace structure of telecommunications networks on the basis of optimal size for multipath circuit control. Programming language: BASIC (VT-20). Programmers: Zoltan Dely and Gabor Kollath, PKI [Postal Experimental Institute]. Proprietary institution and experts: POTI [Postal Planning Office]; Gyorgy Perlaki, Dr Gyula Sallai and Zoltan Dely. Date of preparation of report: "Computer Design of Transmission Networks," a study prepared for the POTI, 1981.

Name: MALIN. Content: Calculation of the regional distribution of telephone main line needs knowing the service characteristics by subscriber category. Programming language: BASIC (PDP-8). Programmer: Dr Gyula Sallai, PKI. Proprietary institution and experts: PKI; Dr Gyula Sallai and Gyorgy Oprics. Date of preparation of report: "Computer Calculation of Traffic Distribution," a PKI study.

Name: TRAVER. Content: Calculation of traffic initiated and completed by telephone exchanges knowing specific traffic initiated, subscriber distribution and maximal traffic asymmetry. Programming language: BASIC (PDP-8). Programmer: Dr Gyula Sallai, PKI. Proprietary institution and experts: PKI; Dr Gyula Sallai and Gyorgy Oprics. Date of preparation of report: "Machine Calculation of Traffic Distribution," a PKI study.

Name: TRAMAT. Content: Calculating the distribution of traffic between exchanges on the basis of traffic initiated and completed and the interest characteristics, using the Kruithof method. Programming language: BASIC (PDP-8). Programmers: Mrs Gabor Ecsedi and Dr Gyula Sallai, PKI. Proprietary institution and expert: PKI; Dr Gyula Sallai. Date of preparation of report: "Machine Calculation of Traffic Distribution," a PKI study.

Name: BLOMIX. Content: Optimally distributes the entire area fed, presuming two exchange systems of different types, for example analog and digital, among the given number of exchanges, taking into consideration and determines their optimal locations, taking into consideration the existing exchanges, the feed areas not regrouped, the transmission devices and prescriptions and the suitability of remote subscriber units. Programming language: BASIC (PDP-8). Programmer: Dr Gyula Sallai, PKI. Proprietary institution and expert: PKI; Dr Gyula Sallai.

Name: REMAN. Content: An interactive program system suitable for calculations connected with the reliability parameters of electronic equipment and systems (analysis, estimates, redundancy, reserves, test plan). Programming language: FORTRAN IV PLUS. Programmers: Dr Gyorgy Farkas and Dr Rudolf Foldvari, BME-HEI [Signal Technology Institute of the Budapest Technical

University]. Proprietary institutions and experts: MMG-AM [Mechanical Measuring Instruments Factory Automation Works]; Ferenc Toth (MMG-AM) and Dr Gyorgy Farkas (BHE-HEI). Date of preparation of report: Documentation, 1981; Users' Guide, 1981.

Name: REGRA. Content: The program package is suitable for determining the reliability characteristics of large-scale systems and networks provided with reliability graphs on the basis of the parameters of the subassemblies used. Programming language: PL-1. Programmer: Zoltan Marton. Proprietary institution and expert: BME-HEI; Laszlo Jereb. Date of preparation of report: Diploma plan, 1981.

Name: MASAS. Content: The program package is suitable for the analytic and simulation determination of the characteristics of continuous and discrete-time Markov chains. Programming language: PL-1. Programmer: Dora Maros (Mrs Takacs). Proprietary institution and expert: BME-HEI; Laszlo Jereb. Date of preparation of report: Diploma plan, 1981.

Name: ESTON. Content: The program package is suitable for long-range planning of trace lines for interurban and large city telecommunications networks. Programming language: PL-1, Assembler. Programmers: Dr Rudolf Foldvari, Laszlo Jereb, Geza Morvay, Dr Laszlo Osvath, Dr Gyorgy Pongor and Istvan Toth, BME-HEI. Proprietary institution and expert: PKI; Dr Gyula Sallai, PKI, and Laszlo Jereb, BME-HEI. Date of preparation of report: Users' description, 1981.

Name: Program system for designing crystal filters. Content: The programs design filters built up with ladder connection of individual resonators, with chain or parallel connection of X members or with parallel connection of two-gate resonators. Programming language: FORTRAN IV. Programmers: Dr Mrs Laszlo Horvath and Kalman Elek, BME-HEI. Proprietary institution and expert: OMFb [National Technical Development Committee]; Dr Jozsef Budinszky. Date of preparation of report: "Designing Crystal Filters," a study, 1981.

Name: CTD-FAP. Content: Frequency range analysis of a system consisting of sampling recursive CTD filter and analog pre- or post-filters. It can take into consideration charge loss and distortion due to sampling and holding. Programming language: FORTRAN IV. Programmer: Dr Tibor Tron, BME-HEI. Proprietary institution and expert: OMFb; Dr Jozsef Budinszky. Date of preparation of report: Users' guide for the CTD-FAP CTD filter analysis program, June 1981.

Name: FIR. Content: Design of linear phase, nonrecursive (finite impulse response), discrete-time (digital, transversal) filters. Programming language: FORTRAN IV. Programmers: Dr Jozsef Gaal and Jozsef Semegi, BME-HEI. Proprietary institution and expert: OMFb; Dr Jozsef Budinszky. Date of preparation of report: Users' guide for a program to design linear phase FIR filters, June 1981.

Name: IIR. Content: Cascade synthesis of minimal phase, recursive sampling filters. Programming language: FORTRAN IV. Programmers: Dr Jozsef Gaal

and Jozsef Semegi, BME-HEI. Proprietary institution and expert: OMFb; Dr Jozsef Budinszky. Date of preparation of report: Users' guide for a program to design recursive sampling (IIR) filters, November 1981.

Name: SCAN. Content: Frequency range analysis of so-called switched-capacitor networks consisting of capacitors, operational amplifiers and switches. Programming language: FORTRAN IV. Programmers: Dr Laszlo Gefferth and Gabor Kalvach, BEM-HEI. Proprietary institution and expert: OMFb; Dr Jozsef Budinszky. Date of preparation of report: Users' guide for the SCAN SC analysis program, June 1981.

Name: Designing SC filters with optimization, with the optimization simplex method. Content: Cascade synthesis of switched capacitor filters. Programming language: FORTRAN IV. Programmers: Dr Edit Halasz, Dr Tamas Fulop, Tamas Molnar and Laszlo Toth, BME-HEI. Proprietary institution and expert: OMFb; Dr Jozsef Budinszky. Date of preparation of report: "Computer Design of Martin-Sedra Type SC Filters," Users' guide, 1981.

Name: Optimization of SC filter design, from basic members of the Fleischer-Laker type. Content: Cascade synthesis of switched capacitor filters. Programming language: FORTRAN IV. Programmers: Dr Edit Halasz, Tamas Molnar and Laszlo Toth, BME-HEI. Proprietary institution and expert: OMFb; Dr Jozsef Budinszky. Date of preparation of report: "Computer Design of Fleischer-Laker Type SC Filters," Users' guide, 1981.

Name: REDENO. Content: Design and frequency range analysis, in the interactive mode, of finite impulse response, transversal structure low-pass and quadrature filters (Hilbert transformers). Programming language: TPA [stored program] FORTRAN IV. Programmers: Dr Jozsef Gaal, Peter Macskassy, Dr Gabor Pronay, Dr Janos Solymosi and Dr Tibor Tron, BME-HEI. Proprietary institution and experts: REMIX; Karoly Papp and Dr Gabor Udvarhelyi. Date of preparation of report: Users' guide for the REDENO referent nonrecursive filter designing program, October 1981.

Name: NOFIDA. Content: Design and frequency range analysis, in the interactive mode, of finite memory, transversal structure, optional amplitude characteristic and linear phase sampling filters. Programming language: TPA FORTRAN IV. Programmers: Dr Jozsef Gaal, Peter Macskassy, Dr Gabor Pronay, Dr Janos Solymosi and Dr Tibor Tron. Proprietary institution and experts: REMIX; Karoly Papp and Dr Gabor Udvarhelyi. Date of preparation of report: Users' guide for the NOFIDA nonrecursive filter designing and analysis program system, October 1981.

Name: GHU. Content: Determining tuning specifications for LC filters starting from TOLOPT data, using the sensitivity according to specification. Programming language: ICL 4-70 FORTRAN. Programmer: Dr Laszlo Gefferth, BME-HEI. Proprietary institution and experts: Telephone Factory; Jenő Radvány and Laszlo Szente. Date of preparation of report: Users' guide for a program calculating GHU tuning specifications.

8984

CSO: 2502/53

## ELECTRONIC TELEPHONE SYSTEM

Budapest HIRADASTECHNIKA in Hungarian Vol 33, No 8, 1983, back cover

[An advertisement of the BHG Signal Technology Enterprise: "ASTERISK Radial Net Electronic Telephone System"]

[Text] Work and process control these days increasingly requires the security of information exchange and the swift and reliable transmission of decisions. In the interest of realizing these goals the BHG [Beloianisz Signal Technology Factory] has developed its ASTERISK centralized control telephone system. In this system the person in control can contact any of the substations at any time or can take action immediately with knowledge of the information arriving from them. If necessary, a conference link can be established with the substations and the conversations can be recorded with a tape recorder. The central unit has a loud-speaker microphone. The telephone system can be set up on a customary two-wire cable network. It can be used for work control in factories, plants and warehouses, for control of industrial and agricultural sites and oil and natural gas production operations, for railway station traffic control, for a camping, motel or hotel dispatcher service or for power plant and substation process control.

## Services

The center can serve a maximum of 20 or 39 substations in 2 versions. We deliver the central equipment in a boxed version also, with 20 lines, which can be placed on a desk or wall. Within a given type the substations can be expanded in a simple way by plugging in printed circuit boards. Substation, main or associate center lines can be attached to the center according to need--depending on the type of line fittings used. Operation of the center is noiseless and it can be placed in an office. The circuits are made up of analog and digital integrated circuits. The equipment operates from grid or battery. In case of grid failure the switch to battery is automatic, ensuring uninterrupted operation.

Technical Data

Number of lines which can be connected	20 or 39
Voice frequency transmission band	300-3,400 Hz
Junction impedance	600 ohms
Insertion loss	Adjustable between 0 and 7 dB
Transmission path between center and substation	2 lines
Maximal loop resistance with telephone set	1,200 ohms
Number of substations which can be connected in conference	Maximum of 10
Ring voltage	60 V, 25-50 Hz
Operating environment temperature	Plus 5 to plus 40 degrees C
Size (in mm)	Breadth      Height      Depth
Central equipment (to 20 lines, boxed)	440          280          300
Central equipment (to 39 lines, cabinet)	1,280        560          470
Set	500          170          370
Substation	Desk telephone

BHG Signal Technology Enterprise, PO Box 2, Budapest 1509, Telephone: 453-300  
Exported by BUDAVOX H-1392, Budapest, PO Box 267.

8984

CSO: 2502/64

## NOTABLE HUNGARIAN ACHIEVEMENTS IN PROLOG APPLICATIONS

Budapest NEPSZABADSAG in Hungarian 23 Aug 83 p 10

[Article by Gabor Pal Peto: "Internationally Recognized Hungarian Achievements in Computer Technology: Logic Programming"]

[Text] The triannual congress of computer scientists will be held this autumn in Paris. Generally, during this international conference hundreds of lectures are given. There are a few lectures, however, which cannot be volunteered for but rather are given by experts invited by the organizers of the congress. The giving of such invited lectures is considered a great professional honor. This is why it is noteworthy that at the Paris congress two Hungarian experts, two associates of the Computer Technology Coordination Institute, Balint Domolki and Peter Szeredi will be delivering such a lecture under the title "Prolog in Practice."

## The Fifth Generation

The names of the two authors are familiar to those interested in the science: during the annual general assembly of the Hungarian Academy of Sciences, the members of the research group managed by Balint Domolki received an Academy Prize for their achievements in the development of the MProlog computer language. These achievements were already mentioned many times at international scientific conferences; for example, a famous U.S. computer expert at the conference held in London under the title "Japan and the Fifth Generation" emphasized in his lecture that in the area of Prolog (logic programming; described in more detail below) large scale experimental systems have been placed in operation in Hungary, which assist chemists in the pharmaceutical industry. Moreover, having stated that in this area Japan became the leader, "naming the countries according to the amount of work performed in this area" he mentioned our country as number three, following the United States and the United Kingdom--having passed France, Sweden, Canada and about a dozen other developed countries.

What is then Prolog, whose importance--as one can already suspect from the foregoing discussion--is related among other things to the Japanese fifth generation computer project, which was called last year by a computer conference held in London "the dawn of a second computer era"?

Perhaps it is a good idea to remember here what the Japanese fifth generation computer is.

The fifth generation, whose development will take 100 million dollars until 1990 will result in a significant departure, qualitative change from the current one: it will create computer tools and systems, which are close to human activities, perception and thinking process.

Prolog became quickly popular in computer science; it has been discussed, taught, received an independent technical magazine but found few practical applications. Hungary is among the first to use it.

How did Prolog find its way to our country? Well, via the usual channels of scientific exchanges: participating in various delegations and conferences Hungarian experts became familiar with it and brought home their knowledge and interest. They became involved with it, first in theory only, since every professional is excited and attracted by new developments in his field. Luck also played its part.

The Hungarian experts happened to work in the institute, which was then called NIM IGUSZI [the Management and Administration Institute of the Heavy Industry Ministry] and were located in the same building with pharmaceutical and architectural design professionals. That is how the idea came up to use the new process in these fields.

In the Same Room With Architects...

Another interesting twist. Prolog was introduced to our country along with the FORTRAN interpretive program written in Marseille; but this turned out to be so difficult to "resurrect" that an independent interpretive program was written in CDL [Computer Design Language] instead. This proved to be effective and portable, i.e., usable on different computers. Thus between 1975 and 1980 the interpretive program for Prolog was installed in fifteen national institutes. In the meantime, the research effort was moved to SZKI (in 1977), which has a large Siemens computer. Thereby the application possibilities were enhanced.

How is Prolog used for pharmaceutical and architectural design? This language is best suited for the solution of such problems which permit a definition of the requirements which must be satisfied, but would be difficult to write a program to find the solution. For example, if we want to design a multiapartment building, there are some requirements. Some of these appear primitive to humans, but it is not obvious to the computer that a room has four walls or to have a door between two adjacent rooms.

There are more complicated requirements, too: such as the dimensions of the room which--if we use prefabricated elements, panels--can only be of a certain length, i.e., the length of the panels or their whole number multiple. Furthermore, each apartment requires a bathroom, water block and so forth. From these data, one can write a program in any of the traditional programming

languages, which puts together based on these data the design of an apartment or a floor. We can define in Prolog these requirements (in a language that can be read with a little practice), and the system then finds objects--in this case the coded program of apartment floor plans--which satisfy these requirements in dimension; floor plans which fit together in the building and are not in conflict. It is then a simple task for the computer to display the drawings of the floor plans created. The designer then can choose from the complete drawings.

#### Practical Achievements, Future Plans

Let us become acquainted with the outline of the other national Prolog-design task. The majority of medicines is a large, complicated organic (carbon-) compound or molecule. Research of new medicines today is conducted by first designing the molecule in theory and then producing it and testing its effect. This design effort has two subtasks which are difficult to tackle by conventional computer tools or to handle the data. The first one: in this complicated molecular structure, we must find those parts which have certain characteristics. The second one: the examination of interaction between the medicines. Many such interactions, or the rules describing them are known; these must be simultaneously known and applied. Via the application of Prolog, these two subtasks can also be handled.

In addition to these, the Hungarian research scientists found many more applications for Prolog; e.g., in machine industry, modelling and even as a software development aid.

Thus Prolog--in its Hungarian version--turned out to be very useful; besides its above mentioned applications, it is counted among the first European practical achievements in so-called professional systems. (By professional system we mean the application of such computer-stored information group which provides the complete knowledge base of a given technical field in a connected computer network.) Thus when in the beginning of the eighties the interest in Prolog grew for several reasons, Hungary was in a very advantageous position to join the common effort.

Attempting to use Prolog for really large-scale tasks, it turned out that certain things must be done differently. Based on this experience, national research scientists started the development of a newer Prolog system between 1978-1979: this is MProlog, where M stands for modularity, i.e., the large program can be made up of several independent parts, which can be written and tested independently. Furthermore, MProlog has the advantage of portability: It can be used on Siemens, IBM, VAX, PDP, ESZR and other computers. Some of its versions can be regarded as a final product, which can be sold and--for the time being mostly as a test model--is used in more than a dozen places, at Edinburgh University (the birth place of Prolog), Nijmegen University (Holland), Ottawa University, the Schlumberger Company in Paris, the Imperial College in London and at two Japanese companies.

The decision made public in 1981 to use Prolog as the base language of the Japanese fifth generation computers gave a great boost to the development of

Prolog. The international marketing of Prolog has been initiated, and--in part as a result of the trend caused by the Japanese plan--there is a significant interest in MProlog as a logic programming system best suited for the handling of practical tasks.

Another important goal of the national development is to create a mini-Prolog system, which can be used on smaller computers.

Thus in one of the most modern intellectual (software) areas of computer technology our experts are in the forefront and deserve national and international recognition.

9901

CSO: 2502/85

## GRAPHIC DESIGN PROGRAM SYSTEM AND ITS APPLICATIONS

Budapest FINOMMECHANIKA, MIKROTECHNIKA in Hungarian Vol 21 No 11, Nov 82  
pp 337-340

TARI, ISTVAN GABOR, LEOVITS, EVA KALMAN, Dr, Mrs, and SPARING, LASZLO,  
Budapest Technical University

[Abstract] The Computer Technology Group of the Mechanical Engineering Faculty of the Budapest Technical University has developed a computerized geometric program system for the design of various objects. The computer used was an ODRA-1204 with 16 K words (24-bit words) of operational memory and a speed of about 60,000 fixed-point additions per second or about 950 floating-point divisions per second. The magnetic drum used as background storage has a capacity of 256 K words. The Computer Instrumentation Limited graphics machine can produce drawings 840 mm wide and 25 m long with 2 pens. Digitalized data is recorded on punch tape. Relatively large amounts of data can be moved in the interactive mode. The segmented program behaves like a single program. There are I/O, editing, drawing, preprocessor, curve, section and special-surface segments. Educational applications include the portrayal of catastrophe surfaces, periodic solution of differential equations and Brownian movement. Design applications include auto-bus body drawings, NC machinetool tape checking displays and direct-mold drawings. A portable version for the TPA 1140 computer will be prepared in the near future.

Figures 9; references 9: 3 US, 1 German, 5 Hungarian.

8984

CSO: 2502/68

COMPUTER-AIDED DESIGN-PRODUCTION-CONTROL SYSTEM FOR PRINTED CIRCUIT BOARDS  
AND SUBSYSTEMS BUILT OUT OF THEM AT THE TELEPHONE FACTORY

Budapest HIRADASTECHNIKA in Hungarian Vol 33, No 8, 1982 pp 368-379

VALLO, PETER, SASS, SANDOR, FRIDRIK, MARTA and PAL, IMRE

[Abstract] The third part in a series, the article describes a design-production-control (DPC) system for printed circuit boards (PCB) at the Telefongyar. The plant, with an area of 1,100 square meters, was established in 1980 to process 360 x 460 mm boards. The technique used is subtractive, but additive technology could be added. The equipment and technology were delivered by the ITC Intercircuit firm, FRG. A manually controlled drill is used for traditional paper phenol resin sheets, but high-precision NC drills are used for the glass epoxy resin sheet intended for mechanical assembly and soldering. The UV coatings are supplied by the Pangolin firm, FRG, and the Dynachem firm, UK. Photo emulsion solutions are provided by the Swiss Ulano firm. Developing is done with DEA 1200 equipment, US. A "Multimat" microprocessor controls the bore metallization and design galvanization equipment. The 180 B etching equipment is manufactured by the DEA firm. Quality control equipment includes an OPTIC-AIDE device, FRG, a Betascope, FRG, and several devices from GDR Zeiss. Only perfect PCBs are allowed to leave the factory. Figures 7, no references.

8984

CSO: 2502/64

## MICROCOMPUTER PERIPHERALS

Budapest FINOMMECHANIKA, MIKROTECHNIKA in Hungarian No 10, Oct 82 pp 300-304

[RONAI, TIBOR, of LSI [Large-Scale Integration] ATSz [Application Technology Advisory Service]]

[Abstract] Need has developed recently for appropriately sized and priced home computer peripheral. TV sets are usually used as display units and cassette tape recorders or floppy discs as storage units. Alternate output units which provide hard copy (printers) are desirable in some cases. Cost is an important consideration.

Japan's EPSON firm and its European subsidiaries produce the MX 80 dot matrix printer. This is the world leader in popularity, even IBM uses it with its personal computer. We also hope to produce it in Hungary. Negotiations have begun to purchase the license. It has four print styles, and one microchip controls all its functions. Its software has tabulation capabilities and it can be adapted to many personal computers.

The MX 80's control box has four output indicators: Power, On-Off Power, On Line, Off Line. No data are lost even when the printer goes off-line due to malfunction or lack of paper because its transition buffer stores such data. It is also equipped with audio warning for out of paper.

A self-diagnostic feature indicates the most common breakdowns, and it can also test interface logics.

The MX 80 is composed of three main parts: 1. a Model 3210 printer with 9x9 pin print head; 2. printed control circuit card; and 3. electric feed unit (5V DC for the logic circuit and 24V DC to drive the printing head and step motor.)

A brief discription of reset and operating procedures is given, followed by basic data on the interface. The standard codes are tabulated, and control codes briefly described. Detailed information is offered to potential users in Hungary by contacting the address given at the end of the article.

Figures 4; tables 2; no references

8584

CSO: 2502/69

## CONSTRUCTION OF MAGNETIC BUBBLE MEMORY DEVICES

Budapest FINOMMECHANIKA, MIKROTECHNIKA in Hungarian Vol 22 No 4, Apr 83  
pp 97-102 manuscript received Sep 83

FELLEGI, ENDRE, graduate electrical engineer, MOM Hungarian Optical Works

Abstract This article is meant to familiarize the reader with the specialized demands of bubble memory chip packaging and the design work done in collaboration between MOM and KFKI Central Research Institute for Physics. Design objectives include biasing with permanent magnets within  $\pm 0.5$  percent, production of the rotating and keeper magnetic fields, reliable electrical connections with minimum noise, power dissipation and minimization of eddy currents, climatic and environmental protection. Coils are driven by  $90^\circ$  phase-shifted square waves to reduce power requirements and simplify the driver as opposed to sine waves. The permanent magnets are made of barium ferrite. Calculations for sizing the coils are shown; both coils are driven by identical voltage, at 100 kHz. Stamped bronze is used for the conductor pins, and the keeper field is achieved by tilting the chip carrier  $2.5^\circ$  relative to the pole smoothing pieces, when the pins are soldered in place. Shielding of the critical magnetic field is done by 0.5-0.8 mm thick permalloy sheets. The shaping of the sheet and the placement of the weld are important. Homogeneity of the magnetic field is better when the pole smoothing pieces are made of transformer core steel, but eddy current losses are less if soft ferrite is used. The reliability of the magnetic bubble memories depends on how accurately the working point is located within the biased operating area. Several methods of adjusting the field are described. The only method found to be successful is magnetizing the assembled biasing structure before the plastic encapsulated chip is inserted; then after accelerated aging, by measuring the magnetic field, individual pieces are selectively matched with the correct chip having the appropriate operating field. Figures 7, references 8: 3 Hungarian, 5 Western.

9918

CSO: 2502/66

UDC: 681.327.2.082.78

## MAGNETIC BUBBLE MEMORIES

Budapest MERES ES AUTOMATIKA in Hungarian No 5, 1982 pp 161-163

BODOCS, LASZLO, Central Physics Research Institute, and EORDOGH, IMRE,  
Central Physics Institute

[Abstract] In magnetic bubble memories, information is stored by magnetic domains (bubbles) found in a crystal plate. These can be created by the current flowing through the wire placed in close proximity to the crystal plate. In most memories, the regular and continuous motion of the bubbles is accomplished by the permalloy element mounted on the crystal plate. The bubbles can be detected by the 0.1-1 percent resistance change they produce in the permalloy element. Detection is facilitated by the elongation of the bubbles. The copying of the bubbles is accomplished via splitting them by a pulse. The simplest bubble memory organization is the single-wire design which is configured in an endless loop. Data in this configuration are stored serially, and thus access can be slow, depending on the memory size. More sophisticated bubble memory organizations combine the serial and parallel handling of data. One such design, the block copier, permits the parallel duplication of data by packets. Manufacturing defects of bubble memories can be fatal (rendering the entire memory unusable) or nonfatal (reducing memory capacity). Data corruption and read errors can be caused by accidental faults occurring during the operation of the memory. These can happen when an extraneous bubble is created or a bubble jumps out of position. For increased reliability, fault handling procedures capable of reducing accidental faults are essential. One such technique involves the application of fire codes. This method takes advantage of the burst nature of the faults.

Figures 4, tables 1, references 2: 1 Hungarian, 1 Western.

9901

CSO: 2502/80

## ACTIVITIES OF TELECOMMUNICATION RESEARCH INSTITUTE [HIKI]

Budapest MERES ES AUTOMATIKA in Hungarian No 5, 1982 pp 194-200

[No authors given]

[Abstract] The article describes the activities of HIKI, its responsiveness to the needs of industry and its cooperation with National Development Committee. Several HIKI products are introduced. These fall into four categories: converters, complex semiconductor memory circuits, liquid crystal displays and test equipment. Converters: HAD 10 hybrid integrated circuit 10-bit analog-to-digital (A/D) converter; HDA 06, 05, 04 and 03 eight-bit, TTL-compatible digital-to-analog (D/A) converters; HDA 02 high-speed, 10-bit parallel input D/A, HUF 07 voltage-to-frequency converters; and HPS 04 hybrid integrated circuit DC-DC converters. Complex semiconductor memory circuits: a) p-channel circuits: TMX 8302 P circuit, 2-kbit (256x8) ROM, TMX 8702 AC circuit 2-kbit (256x8) EPROM, TMX 8602 AP circuit, 2-kbit EPROM, b) n-channel circuits: TMX 8101 1-kbit (256x4) RAM, ATMX 8308 P circuit 8-kbit (1024x8) ROM. The capability of LSI and MOS technology exists. Liquid crystal displays: LDP 03 digital panel tester which can be ordered with 9 or 13 mm character sizes. Test equipment: ICOMAT-110 model TR 9576 automatic tester for the functional testing of digital circuits. RAMs up to 64x16 bits and ROMs to 2kx16 or 32x1 bits can be tested with this device. DEVIOM-1 model TR 2270 device which serves for the measurement and classification of resistors.

Figures 9, no tables, no references.

9901

CSO: 2502/80

## SPECIAL PURPOSE EQUIPMENT FOR MICROELECTRONICS TECHNOLOGY

Budapest FINOMMECHANIKA, MIDROTECHNIKA in Hungarian Vol 21 No 11, Nov 82  
pp 341-352

PERENYI, EDE, technical-economic consultant, Microelectronics Enterprise

[Abstract] In its nearly 30 years of existence the Signal Technology Industry Research Institute (HIKI), now the Microelectronics Enterprise (MEV), has developed many special-purpose devices, and microelectronic parts produced by them were used in the INTERKOZMOS space program. One example is the GG-25B screen printing device used in the production of integrated circuits. The CG-63B pneumatic device for screen printing of surfaces of medium size (max. 100 x 460 mm) has a productivity of 8-10 screenings per minute, suitable for industrial mass manufacture. An automatic system consisting of CG-100A screen printer and a CG-101A tunnel furnace has a maximum machine cycle of 1,200 cycles per hour. The CG-145 screen printing and drying unit loads and screens two sheets in parallel. Tunnel furnaces described include the CG-105, CG-26B, CG-62B, CG-115A and CG-57B. The EK-073 coordinate graph to prepare high-precision drawings of microcircuits can attain a cutting precision of plus or minus 0.05 mm. The CG-30 optical reduction camera ensures the preparation of good-quality photo masks. The EK-126B chip seating device seats semiconductor chips in thin-layer or thick-layer circuits. The KF-12 crystal soldering device solders chips onto glass or ceramic carriers, hybrid circuits or integrated circuit frames, with a productivity of 100-150 chips per hour. The MH-12 thermocompression microwelding device has a productivity of 100 bonds per hour. The EK-125 pneumatic screen tension device can handle frames up to 380 x 530 mm. The CG-40C is a semi-automatic value-setting (trimming) device with sand fluidization and particle acceleration unit, manipulator and process control instrument. The EK-160 microcircuit wafer scoring device can be used wherever glass or ceramic sheets need to be cut. The ES-40 vaporization source is an example of devices used in many branches of industry to deposit metallic or nonmetallic layers. The PCE-100 programming device measures and controls the speed of layer building and layer thickness. The DJE-100 ray skipping unit is used to vaporize two-component layers. The HIM-10 (magnetron) atomizing device can be used to produce layers with identical parameters in large series. Acquisition limitations in regard to the building elements limit Hungary in the production of so-called fourth generation special purpose equipment, but the intellectual and manufacturing capacity are such that domestic needs could be met and participation in the international division of labor ensured in the case of appropriate selectivity. Figures 23.

DIAGNOSTICS POSSIBILITIES ON THE KANDOMAT AUTOMATIC TESTER

Budapest HIRADASTECHNIKA in Hungarian No 9, 1982 pp 419-420

MASSZI, MARIA, Mrs, ROEMER, MARIA and TRON, IBOLYA, Dr, Mrs, Kando Kalman  
Electrical Industry Technical College

[Abstract] The article describes the Kandomat automatic circuit-care tester now being developed for instructional purposes at the KKVMP [Kando Kalman Electrical Industry Technical College]. The device allows the validation of cards via the GO-NO GO method. Soft and hard faults are located via functional examination and conventional in-circuit measurements. Kandomat uses the method of post-test simulation. The test parameters in the test program are set for the specifications of manually tested fault-free cards, and the test results are compared and evaluated. Conventional measurement methods are used for the checking of discrete circuit components (resistors, inductors, capacitors, diodes, transistors, varistors and relays), analog circuits (filters, analog IC amplifiers) and digital circuits (inverters, NAND and NOR gates, multibit latches and counters and memory devices). The test program steps are optimized by stopping the test when a fatal fault is encountered.

No figures, no tables, references 7: 1 Hungarian, 6 Western.

9901

CSO: 2502/63

PHOTOLITHOGRAPHIC PRINTERS

Budapest FINOMMECHANIKA, MIKROTECHNIKA in Hungarian Vol 22 No 4, Apr 88  
pp 109-119 manuscript received Sep 83

BALOG, GEZA, Dr, graduate physicist, Microelectronic Company

[Abstract] The author presents a historical review, from 1963 to present, of the various type of printers used in the production of monolithic integrated circuits. Advantages and disadvantages of the various methods are discussed and tabulated, both from technical and economical points of view. Some of the most interesting problems are illustrated with the author's own experiments. Compatibility of the various systems are tabulated and discussed. The selection of a printer or printer systems should be made, knowing what kind of circuits will be manufactured in the next 3 to 5 years. Figures 24, tables 2, references 21: 3 Hungarian, 18 Western.

9918

CSO: 2502/66

UDC: 621.3.049.75.08

## TESTER FOR THE MEASUREMENT OF CARDS CONTAINING HIGH-SPEED CIRCUITS

Budapest MERES ES AUTOMATIKA in Hungarian No 10, 1982 pp 379-382

ZSOM, GYULA, Kando Kalman Technical College, Device and Guidance Technology Institute, FOLDVARI, MARTA, Mrs, Kando Kalman Technical College, Device and Guidance Technology Institute

[Abstract] At the Kando Kalman Technical College, within the framework of a government commission, a card tester system has been developed for the measurement of special cards containing high-speed circuits. This allows the correct adjustment of the circuit under test and the performance of static and dynamic tests to insure the proper functioning of individual components. The system includes an EMG 666 programmable desktop computer, an EMG 5500 waveform analyzer and the card tester target device. Each one of these subsystems contains a microprocessor, communicates via the IEC bus and is software coupled. The purpose of the EMG 666 is to provide overall control, i.e., drive the IEC, handle the test results from the two other subsystems, format printouts, control the printer and provide man-machine interface. The EMG 5500 with its INTEL 8080 chip handles all dynamic measurements. This amounts to the storing of measurement data, the calculation of partial results and their transmission to the EMG 666. The target test device (also equipped with an INTEL 8080 chip) holds the card under test, performs all static measurements (stores and preprocesses the measurement data, accepts control data and transmits the results) and creates the necessary conditions for the performance of dynamic measurements. The system can perform 19 tests on the card and is capable of being used both in the manual and automatic operating modes.

Figures 1, no tables, no references.

9901

CSO: 2502/76

## FAST ELECTRON BEAM WELDING WITH A RAPID TRANSFER SYSTEM

Budapest FINOMMECHANIKA, MICROTECHNIKA in Hungarian Vol 22 No 4, Apr 83  
pp 103-108

TRILLWOOD, R. E., director, Wentgate Engineers Ltd, England  
/Translated from English into Hungarian by Tibor Szucs/

/The original English-language text appeared in METAL CONSTRUCTION No 8, 1981,  
a journal of the British Welding Institute./

/Abstract/ The Rapid Transfer System /RTS/ is described, which made mass-production electron beam welding of small parts feasible. Previously, the main disadvantage of electron beam welding was the long time required to pump down the vacuum work chamber. In the RTS, parts to be welded are advanced automatically in a vacuum sealed tube, similar in principle to the well-known mail chutes. Because pre-suction is carried out during the previously transported part's welding cycle, no added pumping time is needed. Production rate is limited only by the weld time, which is much shorter than in conventional welding. Production rates of 400 to 1,000 pieces per hour are possible. Various weld configurations are described and illustrated. Figures 7, no references.

9918

CSO: 2502/66

## FORECASTING THE PRESS CAPABILITY OF COPPER-COATED MULTILAYER DIELECTRIC SHEETS

Budapest FINOMMECHANIKA, MIKROTECHNIKA in Hungarian No 10, Oct 82 pp 293-299

[RIPPINGTON, G. W., HOLMES, J. B., Bakelite, Ltd in Birmingham, England]

[Abstract] Due to uncertainty and lack of standardization, specifications of press capability are often left up to agreements between supplier and buyer. It is very difficult to place numerical values on pressability which varies with conditions. As the complexity of printed circuit boards is increasing it is important to develop standards. The NEMA (ASTM D617), British Standards (BS 2076), German Standards (DIN 53488) and others developed various test pieces and procedures, but the ones factories have developed for themselves seem to better fulfill the day-to-day production control needs.

Best reproducible results have been achieved by using together the EXCELL and the MARK II tests. These provide information about breakthroughs between adjacent holes of various sizes and shapes, punch burrs (along the hole's rim) and final hole size which is measured by GO/NO GO gauges in 0.01 mm increments. A number of variables such as distance between holes, hole shape and size, and temperature are evaluated.

The Phillips penetration test evaluates the power needed to punch the boards and to retract the punching tool at various temperatures for a variety of board compositions (epoxy/paper, phenol/paper, fiberglass reinforced, etc). Heating does not always solve the problems; some sheets press better and with less energy at room temperature. For the FR 2 phenol/paper sheet the energy requirement decreases as temperature and blasting gap increase. Delamination also increases in the CEM 3 sheets under these conditions.

The authors know of no laboratory tests for blocking and slugging (decrease of hole diameter after pressing); they invite readers' comments also on the "predictability of sheet pressability."

Figures 13, no references.

8584

CSO: 2502/69

HUNGARY

BRIEFS

SIZE OF COMPUTER PARK--According to 31 Dec 83 statistics, there were 919 computers in Hungary. Of these 603 were in Budapest, 19 in Baranya county, 47 in Borsod county, 34 each in Feher and Pest counties, 32 in Hajdu-Bihar county, 25 in Csongrad county and 4 in Nograd county. The foregoing figures do not include mini and microcomputers. [Excerpt] Budapest OTLET in Hungarian 8 Sep 83 p 7]

CSO: 2502

END