

NAVAL POSTGRADUATE SCHOOL MONTEREY, CALIFORNIA



THESIS

**STREAMLINED AUTOMATED LOGISTICS
TRANSMISSION SYSTEM
PROGRAM MANAGEMENT AND COMMERCIAL
SATELLITE SYSTEMS ANALYSES**

by

Ellen E. Roberts

June 1999

Thesis Advisor:

John Osmundson

Associate Advisor:

Douglas Brinkley

19990802 154

Approved for public release; distribution is unlimited

DRG QUALITY INSPECTED

REPORT DOCUMENTATION PAGE

*Form Approved OMB No.
0704-0188.*

Public reporting burden for this collection of information is estimated to average 1 hour per response, including the time for reviewing instruction, searching existing data sources, gathering and maintaining the data needed, and completing and reviewing the collection of information. Send comments regarding this burden estimate or any other aspect of this collection of information, including suggestions for reducing this burden, to Washington Headquarters Services, Directorate for Information Operations and Reports, 1215 Jefferson Davis Highway, Suite 1204, Arlington, VA 22202-4302, and to the Office of Management and Budget, Paperwork Reduction Project (0704-0188) Washington DC

1. AGENCY USE ONLY (Leave blank)	2. REPORT DATE June 1999	3. REPORT TYPE AND DATES COVERED Master's Thesis	
4. TITLE AND SUBTITLE Streamlined Automated Logistics Transmission System Program Management and Commercial Satellite Systems Analyses		5. FUNDING NUMBERS	
6. AUTHOR(S) Ellen E. Roberts			
7. PERFORMING ORGANIZATION NAME(S) AND ADDRESS(ES) Naval Postgraduate School Monterey, CA 93943-5000		8. PERFORMING ORGANIZATION REPORT NUMBER	
9. SPONSORING/MONITORING AGENCY NAME(S) AND ADDRESS(ES)		10. SPONSORING / MONITORING AGENCY REPORT NUMBER	
11. SUPPLEMENTARY NOTES The views expressed in this thesis are those of the author and do not reflect the official policy or position of the Department of Defense or the U.S. Government.			
12a. DISTRIBUTION / AVAILABILITY STATEMENT Approved for public release; distribution is unlimited.		12b. DISTRIBUTION CODE	
13. ABSTRACT (maximum 200 words) Today's fleet logistics operators maintain responsibility for Naval Force sustainment. Without vital data and useful information systems, substantive logistics improvements are difficult to realize. Exploitation of current satellite technology provides unique opportunities for improvements in data-transfer capacity to fleet units. As private industry takes the lead in technological development, the military must closely monitor commercial space-based communications systems. This research analyzed five commercial satellite systems that possess various capabilities, and provides an overview to distinguish their operational characteristics. Information systems must also be developed using an appropriate program management structure, which offers guidance and support. Conclusions are presented for SALTS program management and recommendations are made for several satellite systems that may meet the Navy's requirements.			
14. SUBJECT TERMS Program Management, Satellite Communications		15. NUMBER OF PAGES 102	
		16. PRICE CODE	
17. SECURITY CLASSIFICATION OF REPORT Unclassified	18. SECURITY CLASSIFICATION OF THIS PAGE Unclassified	19. SECURITY CLASSIFICATION OF ABSTRACT Unclassified	20. LIMITATION OF ABSTRACT UL

NSN 7540-01-280-5500

Standard Form 298 (Rev. 2-89)
Prescribed by ANSI Std. Z39-18, 298-102

THIS PAGE INTENTIONALLY LEFT BLANK

Approved for public release; distribution is unlimited

**STREAMLINED AUTOMATED LOGISTICS TRANSMISSION SYSTEM
PROGRAM MANAGEMENT AND COMMERCIAL SATELLITE SYSTEMS
ANALYSES**

Ellen E. Roberts
Lieutenant Commander, United States Navy
B.S., United States Naval Academy, 1986

Submitted in partial fulfillment of the
requirements for the degree of

**MASTER OF SCIENCE IN INFORMATION
TECHNOLOGY MANAGEMENT**

from the

**NAVAL POSTGRADUATE SCHOOL
June 1999**

Author: 
Ellen E. Roberts

Approved by: 
John Osmundson, Thesis Advisor

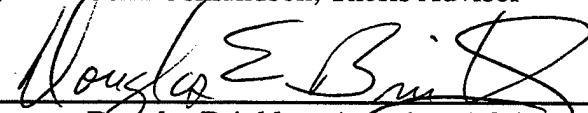
Douglas Brinkley, Associate Advisor

Reuben Harris, Chairman
Department of Systems Management

THIS PAGE INTENTIONALLY LEFT BLANK

ABSTRACT

Today's fleet logistics operators maintain responsibility for Naval Force sustainment. Without vital data and useful information systems, substantive logistics improvements are difficult to realize. Exploitation of current satellite technology provides unique opportunities for improvements in data-transfer capacity to fleet units. As private industry takes the lead in technological development, the military must closely monitor commercial space-based communications systems. This research analyzed five commercial satellite systems that possess various capabilities, and provides an overview to distinguish their operational characteristics. Information systems must also be developed using an appropriate program management structure, which offers guidance and support. Conclusions are presented for SALTS program management and recommendations are made for several satellite systems that may meet the Navy's requirements.

THIS PAGE INTENTIONALLY LEFT BLANK

TABLE OF CONTENTS

I. INTRODUCTION	1
A. INFORMATION TECHNOLOGY	1
B. OPERATIONAL LOGISTICS	1
C. SUPPORTING LOGISTICS WITH INFORMATION TECHNOLOGY	2
D. PURPOSE	4
E. FINDINGS	4
II. LOGISTICS DATA TRANSMISSION REQUIREMENTS	7
A. LOGISTICS DATA	7
1. Requisitions	8
2. Financial Statements	8
3. Other Logistics Files	9
4. Transportation	10
5. Fleet and Squadron Configuration	10
B. OTHER ADMINISTRATIVE AND QUALITY OF LIFE DATA	11
1. Types of Files	11
III. SALTS SYSTEM	13
A. BATCH FILE TRANSMISSION	14
1. File Requests	14
B. USER CAPABILITIES	15
1. Operator Diversity	15
2. Customer Service and Training	15
3. Multiple Communication Channels	16
IV. PROGRAM MANAGEMENT	17
A. MILITARY PROGRAM MANAGEMENT STRUCURE	17
1. Program Phases and Milestones	18

2. Software Development	22
B. SALTS ACQUISITION CATEGORY (ACAT) STATUS	24
1. Program Structure.....	26
2. Original Development Time Frame	28
3. Cost to Develop.....	29
4. Cost to Maintain.....	29
5. Coordination with Other Systems	30
C. SYSCOM SUPPORT	30
V. CURRENT CONFIGURATION	31
A. HARDWARE.....	31
B. COMMUNICATION	32
C. SOFTWARE	32
VI. SALTS CONFIGURATION UPGRADES	35
A. HARDWARE.....	35
B. COMMUNICATIONS.....	36
C. SOFTWARE	37
1. Security.....	39
2. Automatic Program Updates	40
D. FUNDING.....	40
E. COORDINATION WITH NAVSUP.....	40
VII. COMMERCIAL SATELLITE SYSTEMS.....	43
A. SATELLITE SYSTEMS.....	45
1. User Terminal.....	45
2. Space Segment	47
3. Multiplexing.....	49
4. System Characteristics	50
B. COMMERCIAL ALTERNATIVES.....	54

1. International Maritime Satellite (INMARSAT) B	54
2. ICO	57
3. Orbcomm.....	61
4. Globalstar	64
5. Teledesic.....	69
C. COMMERSAT COMPARISON	72
VIII. CONCLUSION.....	77
A. PROGRAM MANAGEMENT	77
B. COMMERSAT	79
C. RECOMMENDATIONS	80
D. RECOMMENDATIONS FOR FURTHER STUDY	81
LIST OF REFERENCES.....	83
INITIAL DISTRIBUTION LIST	85

THIS PAGE INTENTIONALLY LEFT BLANK

LIST OF FIGURES

Figure 1 System Development	12
Figure 2 SALTS Operational Structure.....	14
Figure 3 Program Phases.....	19
Figure 4 Organizational Chart.....	27
Figure 5 Present HW Layout.....	31
Figure 6 SALTS Hardware Upgrade.....	36
Figure 7 Processing Power vs. Modem Speed	37
Figure 8 WinSALTS User Interface.....	38
Figure 9 SALTS Functionality vs. Funding and Data Flow.....	39
Figure 10 Requirements Generation.....	42
Figure 11 INMARSAT Coverage From Ref. [15]	55
Figure 12 ICO System From Ref. [17].....	58
Figure 13 ICO Constellation From Ref. [19]	60
Figure 14 Orbcomm Constellation From Ref. [19].....	63
Figure 15 Globalstar Constellation From Ref. [24]	66
Figure 16 Globalstar Satellite Coverage Areas From Ref. [24].....	67
Figure 17 Teledesic Constellation From Ref. [25].....	70

THIS PAGE INTENTIONALLY LEFT BLANK

LIST OF TABLES

Table III.1 Types of Commands.....	13
Table III.2 Fleet Communication Capabilities	16
Table IV.1 CMM Levels [Ref. 9].....	23
Table IV.2 Acquisition Categories.....	25
Table VII.1 Frequency Band Comparisons	44
Table VII.2 Terminal Classifications	46
Table VII.3 Orbit Latencies.....	48
Table VII.4 System Comparison.....	75

THIS PAGE INTENTIONALLY LEFT BLANK

ACKNOWLEDGMENT

This thesis could not have been accomplished without the support of both my advisors and classmates. A special note of appreciation goes to Jimmy Francis for his honest and pertinent advice.

Cooperation and assistance from the SALTS office were instrumental and greatly appreciated. Any conclusions drawn are solely the authors, not the SALTS team. Their dedication towards keeping the fleet connected is admirable and recognized by every ship on the waterfront.

I. INTRODUCTION

A. INFORMATION TECHNOLOGY

Strategic information management through the use of information technology aims at maximizing improvements in mission performance. The current push within the Department of Defense (DOD) is results-oriented management with which we can improve management information, restructure work processes, and gradually reduce costs while increasing service levels. Without vital data and useful information systems, substantive improvements become unattainable. [Ref. 1]

Unique opportunities for improvement are available for exploitation as long as the technology is aligned with business needs and priorities. Many questionable information systems will continue to be developed unimpeded and under-managed, as leaders respond to crises by purchasing more technology. Naval personnel already hampered by increasing workloads must not be forced to struggle with information systems that add further burdens.

B. OPERATIONAL LOGISTICS

The Naval Supply System Command (NAVSUP) is responsible for providing logistic support to the Naval Forces. One of NAVSUP's aims is to exploit the Internet's capabilities and provide "One Touch" logistics processing for its customers. Logistics is comprised of acquisition, management, distribution, and maintenance of the inventory used to provide replacement parts and other items for sustaining the readiness of ships, aircraft, and other weapon systems, as well as supporting military personnel. Logistics

operations include four major activities: depot maintenance, distribution, materiel management, and transportation.

Distribution is the receipt, storage, issue, and movement of materiel from suppliers to warehouses, or from warehouses to users. Materiel management is the determination of what and how many items DOD needs, how to acquire and where to store them, and the associated inventory management prior to issuance to users.

Transportation is the movement of people and cargo. [Ref. 2] Depot maintenance is the overhaul or repair of restorable and reissueable items.

C. SUPPORTING LOGISTICS WITH INFORMATION TECHNOLOGY

Information technology systems aimed at reducing logistics cycle times, developing a seamless logistics system, and streamlining the logistics infrastructure are a top priority for DOD. The vision of the revamped logistics system is that it will "provide reliable, flexible, cost-effective and prompt logistics support, information, and services to the warfighters; and achieve a lean infrastructure." [Ref. 3] This vision is guided by a principle that highlights the need for near real-time information on material and logistics support capabilities. It also recognizes that the future logistics environment will also require greater mobility and visibility of key assets to provide appropriately rapid responses to changing requirements.

User requirements are generated from multiple sources; including both shore-based installations and deployable units, creating a difficult environment for gathering and distributing information. A tool for broadening the logistics community's ability to communicate with underway vessels and other remotely located units was needed.

Conventional communications channels have proven inadequate to carry both operational

and logistic/administrative data. As Operation Desert Shield/Desert Storm demonstrated, communications requirements over-burdened the existing network and MINIMIZE was imposed. This elimination of virtually all non-tactical communications from the operating theater quickly became a potential threat to sustainment of a protracted military effort in the Arabian Gulf. The Streamlined Automated Logistics Transmission System (SALTS) was designed to fill the void using commercial INMARSAT-A satellites as transmission pipe. SALTS quickly evolved into one of the most widely used fleet logistics tools. Although currently running in the stand-alone format, changing technology and architecture trends are pushing SALTS towards a new, web based solution.

The inherently mobile operational environment and the operational unit's ever-increasing bandwidth requirements demand a comprehensive satellite communications solution robust enough to meet these changing conditions. There are several new commercial options vying for business and within the next five years there will be several more, all with varying capabilities and coverage areas. Thus it is vital that military program managers in conjunction with system users, examine all available alternatives. As it stands International Maritime Satellite Organization (INMARSAT), Globalstar, ORBCOM, Intermediate Circular Orbit (ICO), and Teledesic appear to be the most viable commercial systems for data transmission. Both INMARSAT B and Globalstar are in service, with the others to follow within the next several years. One system eliminated from consideration was Iridium due to its expensive equipment, high usage charges and limited capacity. At 4.6 Kilobytes per second (Kbps), it was designed and is suitable

only for voice transmissions, not data. Another elimination was Skybridge, due to its limited coverage of equatorial and high-latitude regions.

D. PURPOSE

Passing time sensitive data is intrinsic to forward-deployed operational logistic success. Providing fleet logisticians with the required tools is the main objective of the SALTS system. Recently, military satellite (MILSAT) channels have become overburdened during military conflicts; demonstrating that a commercial communications channel is necessary for transmitting logistic data.

The purpose of this analysis is to examine the structure of SALTS program and its associated management structure; and to evaluate potential satellite communication channel upgrades. An alternative for program configuration is considered and five commercial satellite communications systems reviews are performed. The aim of the reviews is not to conduct detailed technical evaluations but to provide long range planning information for possible SALTS program developments.

E. FINDINGS

This new era of commercial satellite communications dramatically expands the available capabilities and features desired by both business and military customers. Competition is driving the market to produce value-laden systems at reasonable prices. Thus, the commercial space sector must be closely monitored with the intent to exploit its developing advantages.

Today's deployed logistics operator is communicating via INMARSAT with SALTS on a daily basis. But as SALTS expands from a Windows based program into a

Web platform this author believes it should be treated as an acquisition program and be relocated at NAVSUP. The overarching balances provided by a tailored acquisition strategy and planned program management would compliment the innovation already demonstrated by the SALTS team. For shipboard operators, the SALTS program could incorporate "One Touch Supply" functions as appropriate; offering them as new SALTS components that would gain immediate user acceptance.

THIS PAGE INTENTIONALLY LEFT BLANK

II. LOGISTICS DATA TRANSMISSION REQUIREMENTS

A. LOGISTICS DATA

The Supply System provides the Navy with essential operating items for ships, aircraft, and facilities; including fuel, food, transportation, clothing, and other services in an effective and economic manner. This mission encompasses a wide variety of disciplines such as inventory control, financial management, contracting, information systems, operations analysis, material and operational logistics, fuels management, and physical distribution. This reflection of the warfighter needs makes the Supply System a critical success factor for the operational efficiency and fighting effectiveness of Naval Forces.

The rapidly shifting strategic balance, including the collapse of the Soviet Union and the ensuing shift in operational focus from open-ocean warfare to littoral operations increases the complexity of logistic support. National Military Strategy indicates that tomorrow's Navy will be an expeditionary force, whose flexibility will be key. And, as history has demonstrated success will greatly depend on timely logistics support. Logistics has thus taken on added importance as operational commanders now seek innovative solutions to war-fighting scenarios.

While all services have traditionally carried out operations overseas, base closures are limiting future land based opportunities. Thus, Naval forces may soon have to fill an even greater role in protecting National Security Interests. [Ref. 4] Remote operations require preplanned supplies and replenishment capabilities and associated strategies must include refined sustainment plans. Sustainment brings about the ever-expanding role of

force logistics and its many different data requirements. SALTS furnishes the remote logistician with a single entry point for Supply System access and file transfer services.

1. Requisitions

Users order both repair and stock replenishment supplies through on board computer systems that create automated requisitions for the material required. These orders or requisitions accumulate within the ship's system until prepared for issue from stock, if the part is on hand; or transmission to the Supply System if not. Requisitions leaving the ship are sent via SALTS for forwarding to DAAS. DAAS then routes the requisitions to the appropriate activity. Upon reaching the designated activity a requisition enters a complex pipeline that includes processing, issuing, procuring (if necessary), and shipping. At each step notification is sent to the ordering activity through SALTS. This notification process provides visibility of a requisition's status to the originator. Timely notification leads to better support through informed customers, who do not blindly wait for a spare part that is unavailable.

2. Financial Statements

Shipboard logistics operators use many different software products to manage various functions. Retail operations are accomplished using the Retail Operations Management (ROM) system. At the end of the retail accounting period financial reporting files are created. Each Navy ship is required to submit various financial reports including: Ship's Operating Target (OPTAR), Food Service, Disbursing and Retail Operations. The timeliness of these reports provides the Type Commander with dependable information on the financial health of the fleet. During times of crisis this information is vital for contingency planning.

Subsidiary reports are also transmitted to fleet units such as Unmatched Expenditure Reports and Depot Level Repairable (DLR) Carcass Reports, each of which requires prompt response or additional charges are incurred. Both the reports and the responses are sent via SALTS.

3. Other Logistics Files

SALTS maintains a database of useful files available for transfer in areas such as Food Service and Retail Operations. These files provide easy access to important information such as publications, notices, bulletins, letters, food warnings, and memorandums. Users merely request the desired files and they are forwarded during the next download. For example, NAVICP instructions are available files from the SALTS download menu.

When material is procured from commercial vendors Fast Pay procedures are followed to avoid late invoice payments and any subsequent interest charges. Reports for these procurements are forwarded from the Fleet Industrial Support Center to the ships for processing. Electronic transmission to deployed ships has significantly cut turn-around times.

Another similar program is the Navy Purchase Card Program, which allows ships to possess their own Citibank Visa card. Like all credit cards, interest accrues if payment is not received promptly. SALTS has been granted access into the bank's system to pull the ship's balance files. Statements are transferred from Citibank to SALTS Central on the 22nd of each month, SALTS determines the end user - then stages the files for delivery. Fleet users receive the electronic statement, view it within the SALTS program, and electronically certify the invoice, then finally forward the certification to Citibank via

SALTS. Citibank then prepares its documentation for forwarding to the appropriate Defense Finance and Service Center for electronic payment. This innovative use of SALTS has again enabled drastic reductions in information cycle times. For fleet units electronic processing has eliminated mail routing delays and eliminated virtually all late fees.

4. Transportation

Once a requisition is processed and the material is shipped to a deployed unit tracking information is forwarded via SALTS to the user. This information can be used to coordinate delivery of material in a foreign port and it also provides tracking information for shipment monitoring. Without prompt notification of shipping status, users would have not insight into delivery possibilities. To this end NAVTRANS and SALTS Central have negotiated an agreement to include the Global Transportation Network (GTN) queries into SALTS.

5. Fleet and Squadron Configuration

Equipment changes and updated maintenance requirements and are integral to ship and aircraft systems supportability. These changes are documented through reports to various activities, which then update system configuration files and respond with new logistics data. New support files are forwarded to the ship or squadron as ship's configuration updates and aviation 3M updates. These updates contain parts listings and maintenance requirements. Again, timeliness directly impacts fleet sustainability.

B. OTHER ADMINISTRATIVE AND QUALITY OF LIFE DATA

SALTS is also a conduit for many non-logistic data files. Perhaps the program could be renamed to more accurately portray its functionality. These additional features provide users with information unattainable from any other source during deployments.

1. Types of Files

As the SALTS program developed, the list of data types transmitted grew quickly. Figure 1 depicts the system's evolution and addition of capabilities. The following non-logistic data files are also transported to remote users via SALTS, for many of them there are no other means to deliver the information:

- News: New York Times Fax and Stars and Stripes
- Personnel/Pay: SDS, Diary entries, Detailers
- Rate Training: Manuals and Courses
- Postal: Mail tracking
- Hazardous Material: Ship's Hazardous Material Inventory List (SHMIL) feedback reports
- Personnel Information: Link Magazine, Training Bulletins, Advancement Results, PARS
- Email: Personal and Official
- U.S. Coast Guard requisitions

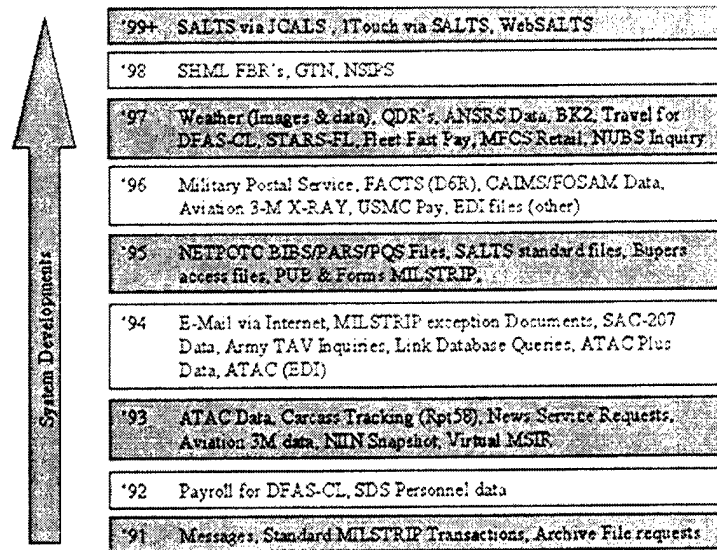

Figure 1 System Development

III. SALTS SYSTEM

The SALTS system provides a reliable, accessible, secure, and easy to use method of transporting logistics data and other files anywhere in the world. The software program is continuously improved to streamline its code and incorporate new and more efficient routines. The hardware is chosen to incorporate the system's need for reliability, security and accessibility. The program's goal is to design and implement the most comprehensive automated integrated logistic tool possible, and to put that tool in the hands of as many remote customers as possible. The worldwide users are distributed as follows in Table III.1:

Unit Type	Quantity
Combatant and Support Ships	347
Naval Shore Based Accounts	1571
US Marine Corps Units	160
Air Force/Army/DLA/Other	170
Military Sealift /Coast Guard	83

Table III.1 Types of Commands

SALTS Central, depicted in Figure 2 is the processing center that processes and maintains the system, including both hardware and software components. It operates and maintains the software and hardware, and orchestrates data brokering agreements.

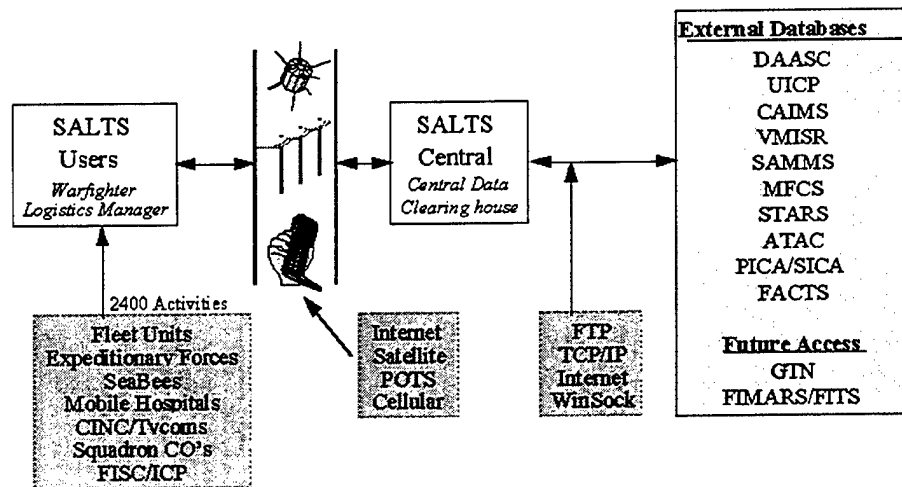

Figure 2 SALTS Operational Structure

A. BATCH FILE TRANSMISSION

In order to limit satellite connection time SALTS Central processes individual incoming files destined for users, sorts them, and creates batch files. These batch files are then placed in the user's mailbox until log-in. Upon log-in, the waiting files are downloaded to the user and messages from the user are uploaded. These batch files can include Internet E-MAIL, Milstrip, Payroll, SDS, Aviation 3-M, Asset Visibility response, NUBS, ATAC, Carcass Tracking, PLTS, Military Postal Tracking, USO Grams, DAO Financial Reporting, and News Services. A new service has also implemented electronic distribution of NAVICP instructions to SALTS customers.

1. File Requests

Within the SALTS software is the capability to request files or information from SALTS Central. The requests are created then combined with the other outgoing files and stored on the operator's computer until the next transmission. User requests can

include database inquiries, specific downloadable files, or even a retransmission of previously received files.

B. USER CAPABILITIES

While the SALTS system is widely distributed, with users at both fleet and shore based commands around the world, the primary design focus concentrates on the principal users consisting of ships, expeditionary units and remote activities. These principal customers drive the system hardware requirements and software capabilities. However, there are also over two thousand connected shore activities with more flexible communication channels. All activities want Push and Pull access to non-tactical data. To satisfy their needs SALTS must provide a comprehensive automated solution.

1. Operator Diversity

The system is designed for operation by enlisted personnel of various ratings, each of which requires system access for different purposes. These ratings include Electronic Technicians (ET) for transmission path equipment and Storkeepers (SK), Mess Specialists (MS), Disbursing Clerks (DK), Ship's Serviceman (SH), Personnelman (PN) and Postal Clerks (PC) for data entry. System use by such a wide variety of ratings mandates a simple, easy to navigate software interface.

2. Customer Service and Training

With customers around the globe support services are performed primarily over the phone or by email to SALTS Central. For new installations and difficult problems, there are also three detachment offices in Norfolk, San Diego, and Pearl Harbor. SALTS Central also provides an informational newsletter to its customers. Training for Supply

Officers has been incorporated into Supply Officer Basic Qualification Course and for enlisted personnel into supply rating A-schools.

3. Multiple Communication Channels

Implementation of a data transmission system aboard a mobile platform dictates the need for a satellite solution. The expense of satellite service in-turn implies alternate connection methods for a ship's in-port periods. Ships in port limit SALTS transmissions to DSN or commercial phone lines. Multiple access methods (Table III.2) provide users with options suitable to their situation or organization. The recent acquisition of Inmarsat B terminals and services provides a new satellite alternative. This variety of connection methods helps ensure accessibility to the SALTS system.

Unit	Channels Available
Large	Internet via Challenge Athena, Inmarsat B
Medium	Inmarsat A or 2 Inmarsat B Channels
Small	Inmarsat A or 1 Inmarsat B Channel
All	Pierside DSN and Commercial Lines

Table III.2 Fleet Communication Capabilities

IV. PROGRAM MANAGEMENT

A. MILITARY PROGRAM MANAGEMENT STRUCTURE

Both industry and government activities have recognized the importance of managing the processes surrounding the procurement of systems. This stems from the need for a cohesive strategy, consistent planning and implementation, and maximum interoperability and performance. This architecture must provide sufficient a framework to establish details planning, development, acquisition, maintenance and ultimately disposal. As such, guidance for all defense acquisition programs is prescribed with the intent of implementing an integrated management environment. This environment encompasses requirements generation, planning, programming, budgeting, and acquisition management. [Ref. 5] It is an event-driven process that emphasizes risk mitigation and affordability, and that explicitly links milestone decisions to demonstrated accomplishments. The Department of Defense guidelines are aimed at effectively translating operational needs into stable, affordable acquisition programs. Guidance also permits rapid incorporation of mature technology through non-traditional acquisition techniques such as prototyping or evolutionary acquisition. This permits quick response to a user's needs and is notably applicable to commercial off-the-shelf items. [Ref. 6]

Acquisitions pass through numerous phases, requiring different sets of expertise for successful completion. Systems Acquisition is becoming progressively more complex, requiring dynamic management techniques. Meanwhile there is pressure to meet stringent timelines within restrictive cost limitations. The ensuing goal is to provide

operationally effective and suitable systems that meet life cycle cost, program schedule, and performance thresholds.

Tailoring the Acquisition Strategy around a specific program ensures the most appropriate management structure is provided. Thus, the system of Acquisition Milestones and Phases is not rigid, and may be modified to meet individual program needs. Phases may be shortened and even eliminated with combined Milestone Decisions. Commercial items and mature technologies do not require an extended Program Definition and Risk Reduction phase, if at all.

During each phase key documents including the ORD, APB, and Acquisition Strategy are updated ensuring continued focus on fleet needs, risk mitigation and CAIV implementation. Since DOD acquisitions are designed to be event driven, vice schedule driven, phase exit criteria should be tied to areas of program risk that require intensive management. At the milestone reviews the decision authority issues an Acquisition Decision Memorandum (ADM), approving entry into the next phase.

1. Program Phases and Milestones

Figure 3 reflects the outlined sequence of program decision milestones and their ensuing phases. It serves as a model that may be altered to reflect program needs.

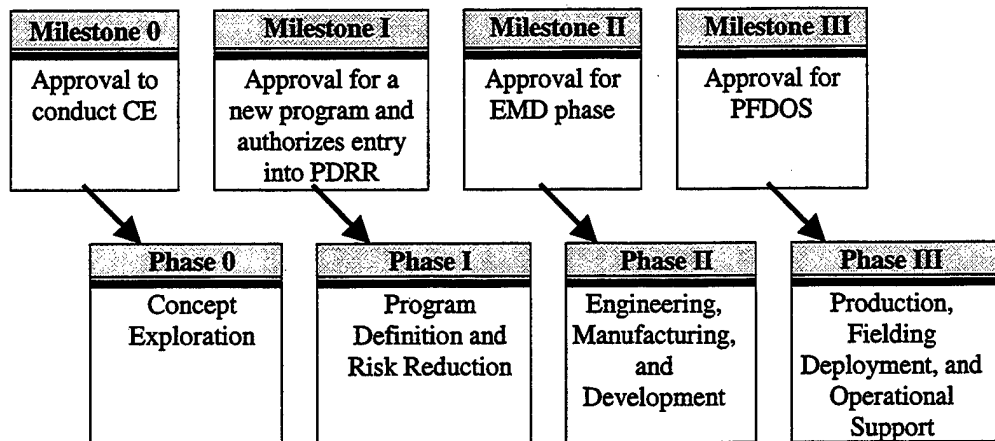

Figure 3 Program Phases

a. Milestone 0

After a Mission Needs Statement (MNS) has been submitted and a favorable assessment of the mission need by the operational validation authority has been granted, the program management process begins. The Milestone Decision Authority (MDA) convenes a Milestone 0 review and issues an Acquisition Decision Memorandum (ADM). The ADM determines if a material solution is warranted, and if so, approves entry into the Concept Exploration (CE) Phase.

b. Concept Exploration Phase

Alternative system concepts and technology reviews are conducted to identify available solutions to satisfy the user's need. The focus is on a competitive exploration of potential ideas, concepts and solutions, while working with industry and the user to foster innovation and determine trade-offs in capability, schedule and cost.

Activities during CE include reviewing experiences with similar systems and identifying viable alternatives. Towards this end contractor proposals are evaluated to select the most promising system design concepts. Then during the evaluation of

competing alternatives, trade-offs of performance, cost, and schedule are assessed to identify and reduce program risk. Key products of this phase are the Operational Requirements Document (ORD), the program Acquisition Strategy, and the initial Acquisition Product Baseline (APB). The APB contains key cost, schedule and performance parameters of the system proposed to meet the mission need. These Key Performance Parameters (KPP) are drawn from the ORD.

The Acquisition Strategy is based on alternatives described by the ORD and outlines plans for overall system development, testing, production, support, and fielding. It should include planning for the use of prototypes and/or models and simulations to assess and reduce risk. The Acquisition Strategy also identifies the process for transitioning critical technologies from science and technology efforts into the phases of system development.

The program manager ensures sufficient funds are programmed so that the system is fully funded in the Future Year Development Plan (FYDP) at Milestone I. Cost as an Independent Variable (CAIV) objectives are concurrently developed by the program manager, assisted by a cost performance integrated product team CPIPT. These CAIV objectives are aimed at controlling total life-cycle costs through cost saving acquisition streamlining and trade-offs between cost, schedule, and performance. [Ref. 7]

c. Milestone I

End products of this phase to be reviewed at the Milestone I review include the initial ORD, performance specifications, technical performance requirements and systems interfaces, and a proposed acquisition program baseline (APB) containing cost, schedule, and performance thresholds and objectives. The Milestone I ADM approves the Acquisition Strategy, APB, Resource Decisions and CAIV objectives, and

Phase I Exit Criteria. The decision to enter into Program Definition and Risk Reduction (PDRR) indicates that the technology reviewed in the CE phase is mature enough for development into a system.

d. Program Definition and Risk Reduction (PDRR) Phase I

This phase results in the selection of a system for development and eventual production. Selection is chosen through testing of critical processes and technologies, risk areas identification, and development of risk abatement plans. Supportability and manufacturing considerations must be also be integrated into the design effort to preclude costly redesign efforts downstream. The phase includes fabrication of prototype systems or subsystems to support design development.

Through integrated product teams (IPTs), updates to the ORD are manifested in the APB reflecting any revised objectives and thresholds, including any proposed changes to cost and schedule objectives and thresholds. As a result of the IPT process, the user and acquisition community can implement changes to baselined cost, schedule or performance objectives necessitated by technology trade-offs or affordability assessments. [Ref. 8]

e. Milestone II

The MDA conducts a Milestone II review and then issues an ADM providing permission to proceed into Engineering and Manufacturing Development (EMD), thus approving the acquisition strategy, the updated APB, updated CAIV objectives, and any exit criteria required to be demonstrated during EMD.

f. Engineering and Manufacturing Development (EMD) Phase

The design established during the PDRR Phase, must now be matured through developmental and operational test activities so it is ready to be produced. All

technical, operational, and funding requirements must be met. The PM must now complete system development to the point that a decision can be made to produce the system in quantity in an economical manner. Development and procurement of production representative systems are conducted to support test and evaluation and evaluate the contractor's ability to produce the end item. A Critical Design Review determines if designs are complete for each configuration item. Logistics considerations, initially identified in the CE Phase, become the focus as the program office analyzes system operational and logistical supportability issues. [Ref. 7]

g. Milestone III

The MDA conducts a Milestone III review and issues an ADM providing permission to proceed after approving the acquisition strategy, the updated APB, updated CAIV objectives, and any exit criteria required.

h. Production, Fielding/Deployment and Operational Support Phase

This phase consists of manufacturing processes, the ensuing contract monitoring, and acceptance testing. Activities include production acceptance test and evaluation, monitoring of the contractor's quality assurance program, and adhering to a production schedule that meets the system's Initial Operational Capability (IOC).

Product improvements, which could be a direct result of feedback from the field, are incorporated either during production or retrofitted in the field. Follow-on Test and Evaluation (FOT&E) may be conducted.

2. Software Development

Information technology (IT) programs must include a variety of engineering, architectural, data structure, and interoperability issues. Considerations for software

intensive systems include open systems design environment, compatibility with the Joint Technical Architecture (JTA), adherence to the Defense Information Infrastructure Common Operating Environment (DII/COE), and the contractor's Software Engineering Institute (SEI) Capability Maturity Model (CMM) level of certification. SEI maintains lists of companies and their corresponding level of software development maturity. The assigned levels (Table IV.1) are indicative of an ability to repetitively produce reliable software. The Software CMM has become a de facto standard for assessing and improving software development processes. CMM describes the principles and practices underlying an evolutionary path from ad hoc, chaotic processes to mature, disciplined software processes.

Level	Maturity
I - Initial	The software process is characterized as ad hoc, and occasionally even chaotic. Few processes are defined, and success depends on individual effort and heroics.
II - Repeatable	Basic project management processes are established to track cost, schedule, and functionality. The necessary process discipline is in place to repeat earlier successes on projects with similar applications.
III - Defined	The software process for both management and engineering activities is documented, standardized, and integrated into a standard software process for the organization. All projects use an approved, tailored version of the organization's standard software process for developing and maintaining software.
IV - Managed	Detailed measures of the software process and product quality are collected. Both the software process and products are quantitatively understood and controlled.
V - Optimizing	Continuous process improvement is enabled by quantitative feedback from the process and from piloting innovative ideas and technologies.

Table IV.1 CMM Levels [Ref. 9]

Ensuring both the SALTS program office and contractor are aware of and are employing appropriate controls is important for continued improvements and success.

Implementation of CMM delineated process can be accomplished through contracting with qualified sources. Thus, CMM status could be included in the required qualifications in the Request for Proposals.

The key differentiation between levels is focus shift from implementation of repeatable process to refining quality process improvements. At Level II is the focus on the software project's establishment of basic project management controls. They include: Requirements Management, Software Project Planning, Software Project Tracking and Oversight, Software Subcontract Management, Software Quality Assurance, and Software Configuration Management.

The key process areas at Level III address both project and organizational issues, Level IV shifts emphasis to Quantitative Process Management and Software Quality Management. Finally, Level V covers issues such as Defect Prevention, Technology Change Management, and Process Change Management. [Ref. 9]

B. SALTS ACQUISITION CATEGORY (ACAT) STATUS

Acquisitions are placed into categories based on their purpose and cost (Table IV.2) as well as visibility, with review and approval authority commensurate to their status. SALTS, as an Automated Information System (AIS) is a combination of computer hardware and software, data, and telecommunications that performs functions such as collecting, processing, transmitting, and displaying information. [Ref. 8]

Acquisition Category	Fiscal Threshold	Milestone Authority
ACAT IC/D	\$355M RDT&E or \$2.135B Procurement	DAB (ACAT ID), Component (ACAT IC)
ACAT IA	\$360M Life, \$120M Total or \$30M in any One Year	OSD (C3I)
ACAT II	\$140M RDT&E or \$645M Procurement	CAE/Service Secretary
ACAT III	No Fiscal Thresholds	Lowest Appropriate Level

Table IV.2 Acquisition Categories

As a low cost, ad hoc system valued at approximately two million dollars per year, SALTS has fallen through the crack. Now in its eighth year, it has never been treated as an acquisition program and does not receive the associated visibility and guidance. This relative anonymity allowed the system to develop quickly without time consuming document preparation and corresponding approval milestone reviews.

Unfortunately the lack of guidance has also permitted development to continue without an acquisition strategy, ORD, or even an APB. These documents, while cumbersome to develop, do serve indispensable roles. Without the user's requirements documented by an ORD it is impossible to define the appropriate system operating parameters. An acquisition strategy should define and implement a program designed to deliver the system required on-time, within cost constraints meeting performance thresholds.

1. Program Structure

Within a service the Component Acquisition Executives (CAEs) supervises the acquisition system and enforces policy. The CAE may also serve as decision authorities for programs other than ACAT ID. This would include a program such as SALTS.

Program Executive Officers (PEOs) review and assess changes reported in assigned programs. They monitor the significance of any problems reported by each PM and review the PM's proposed action plans and the level of risk associated with such plans. PEOs also serve as decision authorities for assigned programs.

System Command (SYSCOM) Commanders provide support to PEOs and PMs and are decision authorities for assigned programs. They provide matrix support for programs, including contracting, technical reviews, logistic support, and comptrollers.

Program Managers (PMs) manage their assigned programs in a manner consistent with the policies and principles articulated in the DOD 5000 series instructions. In addition, PMs follow the phases and prepare for the milestone decisions previously discussed. They provide assessments of program status and risk not only to higher authorities but also to the user. The active management and control applied within approved resources dictates program cost, performance, and schedule.

a. Position within NAVICP

Although assigned to the Naval Inventory Control Point (NAVICP) Philadelphia (Figure 4), the SALTS program actually fulfills requirements that should fall under the purview of NAVSUP. NAVICP is not a systems command and its activities primarily focus on aviation and weapon system support. Consequently, the author feels that SALTS as an automated systems program office is inappropriately located. There is

limited guidance and support for the program management structure, and the command does not have a vested interest in the success of the program. This has left the SALTS office largely unguided and with few reporting requirements. This has left the program to act as a free agent, unrestrained or unassisted by the overhead present in a large organization. While SALTS has been an overwhelming success, its results have thus been derived from the strength of character belonging to the program manager.

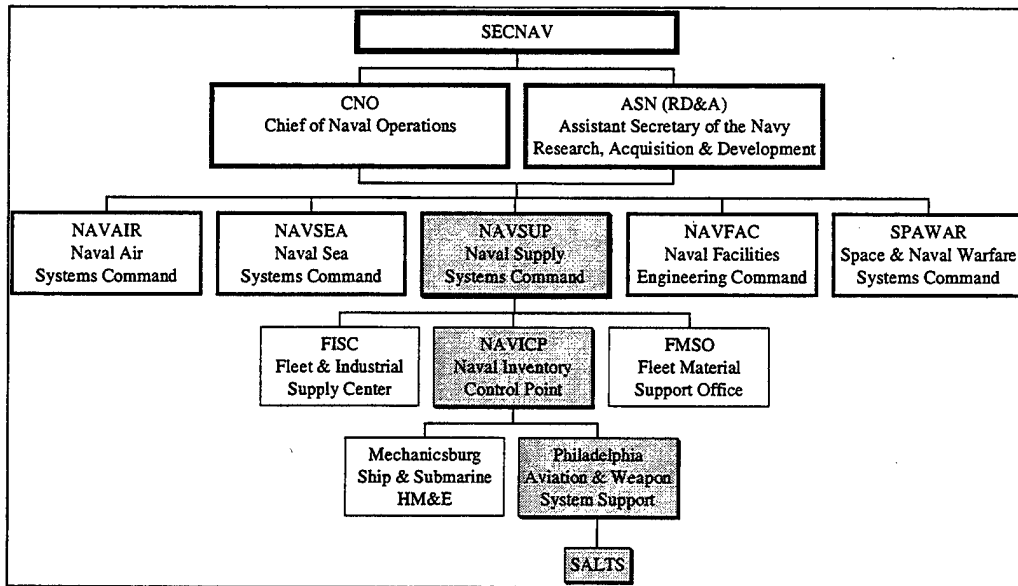

Figure 4 Organizational Chart

b. Military, Civilian, Contractor Manning

Manning within the program consists of a combined Military, Civil Servant, and Contractor Support team. The program manager is a Naval Officer, currently a Lieutenant Commander. His responsibilities encompass all aspects of operational and administrative management, as well as personnel management and contractor supervision.

Contractor support is crucial for both software and hardware expertise, and assistance with program management. The contract vehicle is cost reimbursable with a fixed fee and the line items include provisions for the following:

- HW and SW ADP support
- Programming and SW engineering support for developed applications
- Life cycle support
- Electrical engineering support
- Equipment evaluation and product recommendation
- Test support services for applications
- Develop applications and system models
- Configuration management and technical support
- Maintenance support
- Sight surveys and development of floor plans and bill of materials
- Install and uninstall new equipment and applications
- Equipment management and inventory
- Support training requirements and perform operator training
- Technical publication support
- Inspection and testing of equipment
- Resource management
- Program management support

2. Original Development Time Frame

In three and a half months a small, twelve to sixteen-person team was able to research available options, evaluate interoperability, and select the best solution. Then this software package was installed on every deploying ship/unit involved in Desert Storm. Within six months all units were trained and operational.

Although initially viewed as a temporary solution, SALTS was so well received for both its simplicity as well as its functionality that the users wanted to keep it. Not only did they want to retain the original features but they also requested additional capabilities. Accordingly, the commercial off the shelf (COTS) software was replaced by a slightly more robust version created in the C++ language. Thus began a cyclical, progressive development process of prototyping and installation.

3. Cost to Develop

The cost to develop original SALTS software and procure its corresponding hardware components was approximately two to three million dollars. This estimate does not include personnel costs.

4. Cost to Maintain

The system's simple hardware architecture is designed for ease of maintenance and remote monitoring. This provides the means for reliability and inexpensive support. Software upgrades and maintenance consume the major portion of a two million dollar annual budget. The budget is partially funded by NAVSUP (\$800,000) with the remainder derived from usage charges paid by other commands.

User hardware costs are not included in the maintenance figure. Each unit is responsible for upkeep, maintenance, and replacement costs associated with the computer platform that SALTS resides on. For most commands this is a stand-alone personal computer with a 56Kbps modem.

5. Coordination with Other Systems

SALTS has negotiated data brokering agreements with many different systems thus integrating multiple data types into a single access platform for the user. These systems include Naval and Joint resources, as well as a few commercial sources.

C. SYSCOM SUPPORT

The author feels that NAVSUP, as the SYSCOM directly responsible for logistic systems, should be the driving force behind SALTS. That said, the program receives only moderate support and involvement from relatively few headquarters personnel. This dichotomy may occur due to the low dollar value of the program, although this should not cloud the system's operational value. By all measurements, SALTS is an extraordinarily successful system. Fleet customers universally accept it as the solution that provides a single source for logistic and administrative data. One Touch Supply should build on established SALTS data brokering agreements and the SALTS office should help develop the SOW. This approach could promote a fused data picture between SALTS and the One Touch system.

V. CURRENT CONFIGURATION

A. HARDWARE

A primary objective of the SALTS system was configuration simplicity. This was accomplished through selection of available technology; no new development efforts were conducted. No proprietary equipment was considered, basic off-the-shelf, commercial hardware was used to configure the architecture. As it stands, forty dial-up hosts interface with Windows NT server machines and Oracle database server machines at SALTS Central (Figure 5). Transmission and receipt are conducted utilizing modems and network hardware.

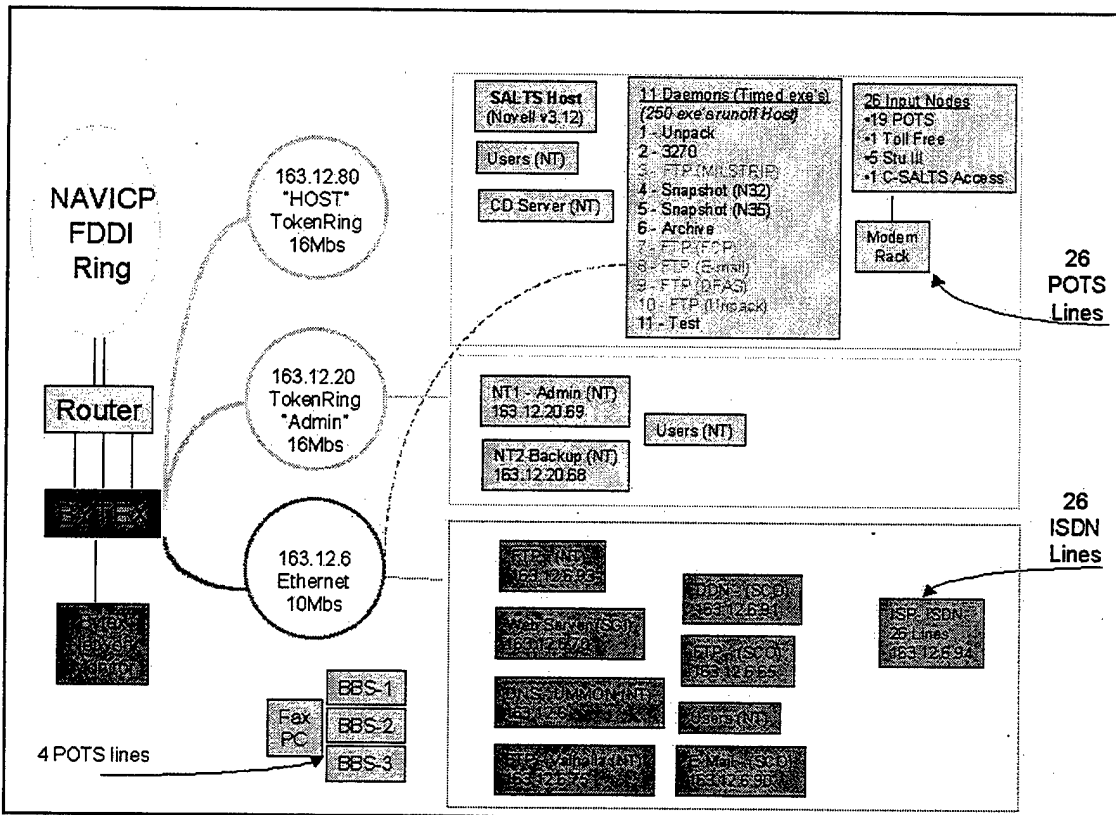

Figure 5 Present HW Layout

B. COMMUNICATION

Data files can be sent to and received from SALTS Central five ways, Commercial Satellite (INMARSAT), Military Satellite (UHF & SHF), Cellular telephone, telephone landline (DSN or Commercial), and via the INTERNET (NIPRNET). While an INTERNET TCP/IP connection can be use to for file transfer, it is not a web page interface but a File Transfer Protocol (FTP) routine within the SALTS software. Secure connections are made using STU-III connections on both the user and SALTS Central ends.

INMARSAT A connections are established at up to 9600 bytes per second (bps). Landline calls are processed by modems limited to 14.4 Kbps while STU-III communications are limited to 9600, but usually occur at only 2400 bps.

C. SOFTWARE

The client is a DOS Application and the host is a SALTS Central server. For file transfer there are ten Servers running twenty-six nodes and thirteen daemons. The daemons gather data from various sources and then compress the information, address them for a particular unit and finally file the information packets. Upon log-in by a unit the files are encrypted then transferred using FTP.

Within the software the user selects options from established menus. Upon completion of a menu item routine the resulting file or request is appended to the batch awaiting transfer. The user can, at any time, establish a connection with SALTS Central. The outgoing files are sent and then those from SALTS Central are pushed to the user. A filter within the program allows customers to limit the individual file size during

downloads. This feature provides user control in preventing long connection times, especially when using satellite services.

THIS PAGE INTENTIONALLY LEFT BLANK

VI. SALTS CONFIGURATION UPGRADES

A. HARDWARE

SALTS Central re-host plans are under development as the existing equipment is currently running near capacity. Figure 6 depicts the planned architecture with two Silicon Graphics server machines. Once installed the hardware will shift from over forty personal computers to two machines with remote administration. To ensure accessibility and availability the new configuration will provide complete redundancy through use of mirrored database. The mirror system will come on line automatically if the primary machine experiences trouble. The new hardware is IT 21 compliant as well as NIPERNET Firewall Policy compatible. All attempts have been made to adhere to open standards and the hardware and operating system have also been certified as DII/COE/GCSS compliant.

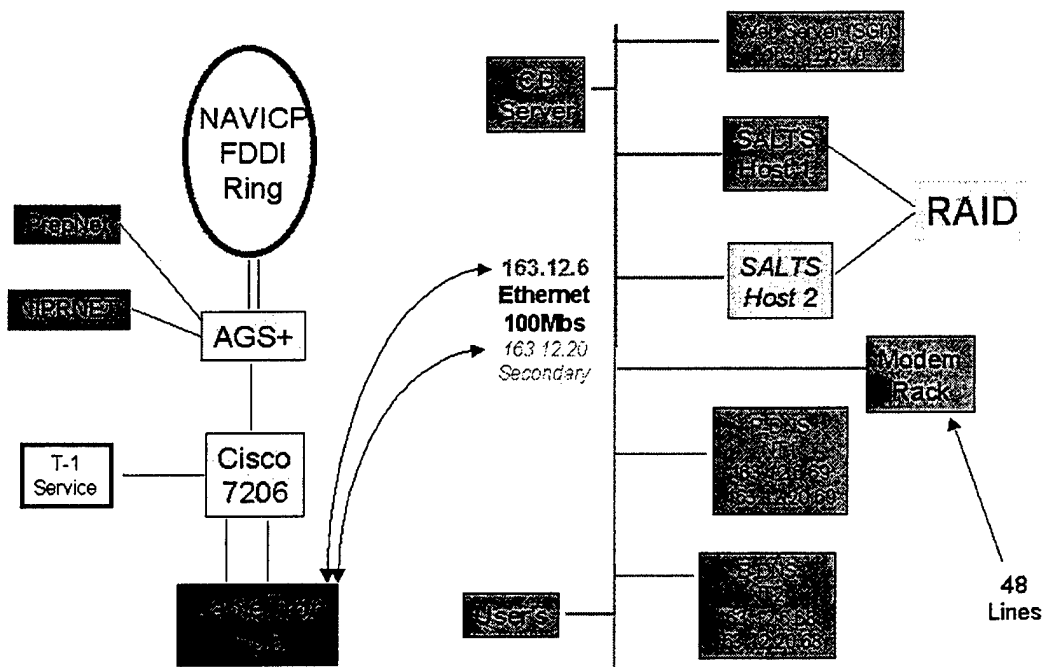

Figure 6 SALTS Hardware Upgrade

B. COMMUNICATIONS

The system upgrades will greatly enhance communication capabilities. All previous methods of reaching SALTS central will remain in place but the transmission capacities will be enhanced. The previous modem bank was limited to twenty-six lines at 14.4 Kbps while the new implementation will hold forty-eight at fiftysix Kbps. These upgrades are in response to changing fleet capabilities. The fleet is slowly incorporating two new transmission methods, Inmarsat B terminals and Challenge Athena link access that reach sixty-four Kbps and 1.544 Megabytes per second (Mbps). Both are commercial satellite systems but Challenge Athena availability is limited to large ships.

The additional bandwidth that is required for effective web browsing has steadily increased as the size of individual web pages has grown. Today the average page reaches

five hundred kilobytes. Deluxe, graphic intensive pages can reach up to 20 Mbps. If SALTS transitions to a web based version careful consideration of access methods must occur. While processor speeds have dramatically improved, communications continue to lag, as demonstrated in Figure 7. The long delays produced by relatively slow satellite links could severely and negatively impact user effectiveness and exponentially increase communication costs.

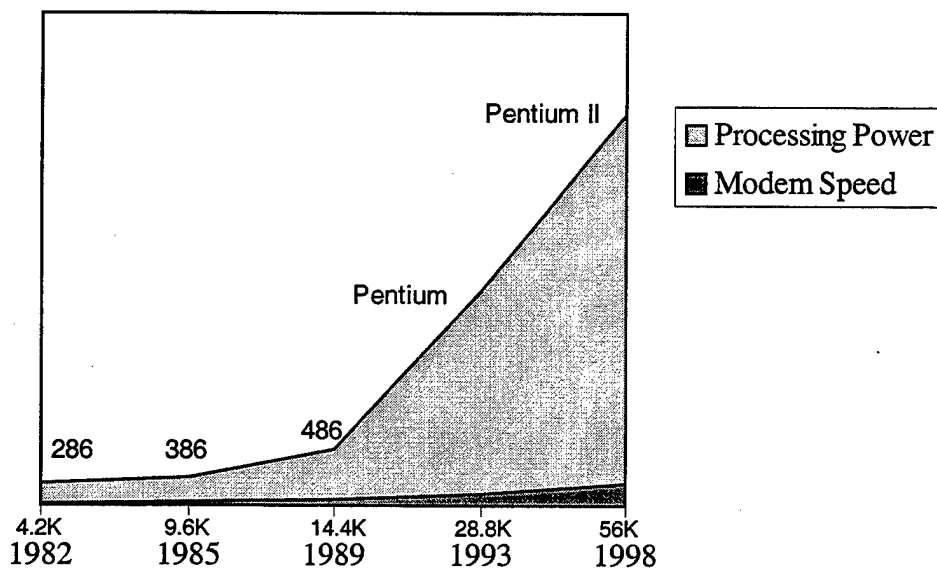

Figure 7 Processing Power vs. Modem Speed

C. SOFTWARE

Currently SALTS Central is completing the conversion from the previous DOS version to Winsalts, a Windows based solution (Figure 8). From here guidance from the Navy Supply Systems Command (NAVSUP) is to provide a web-based version for “One Touch” logistics processing.

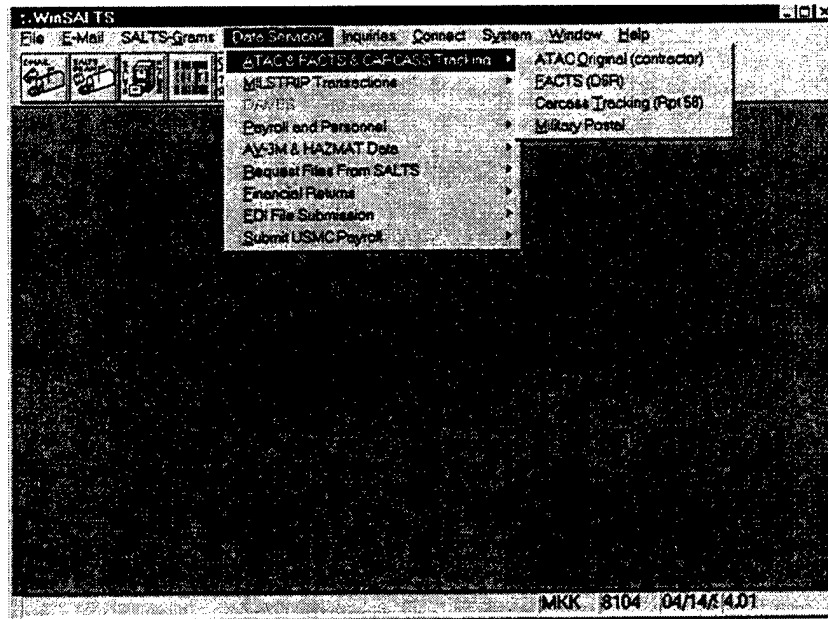

Figure 8 WinSALTS User Interface

The site will be designed to provide customers with a single point of entry with a single login that allows access to a host of databases & services. A trusted relationship with data owners will be developed to afford One Touch the capability to present their customers with the ability to:

- Obtain requisition status information
- Obtain Stock Check information
- Perform input and submission of both standard and non-standard requisitions
- Perform a technical screening

The upcoming developments include a Client – Server Architecture with the Client running on any windows capable platform and the server on any Platform running Windows NT Server. A LAN Version or Web/Intranet Version proposes the Client as any browser on any platform connecting using TCP/IP with a web server residing at SALTS Central.

In an attempt to improve the already vast array of available information increased capabilities include: NAVAIR X- Rays, QDRs / RODs, GTN, and ARTIS. These additions will be incorporated into a system that already enjoys high user familiarity and exceptional ease of use.

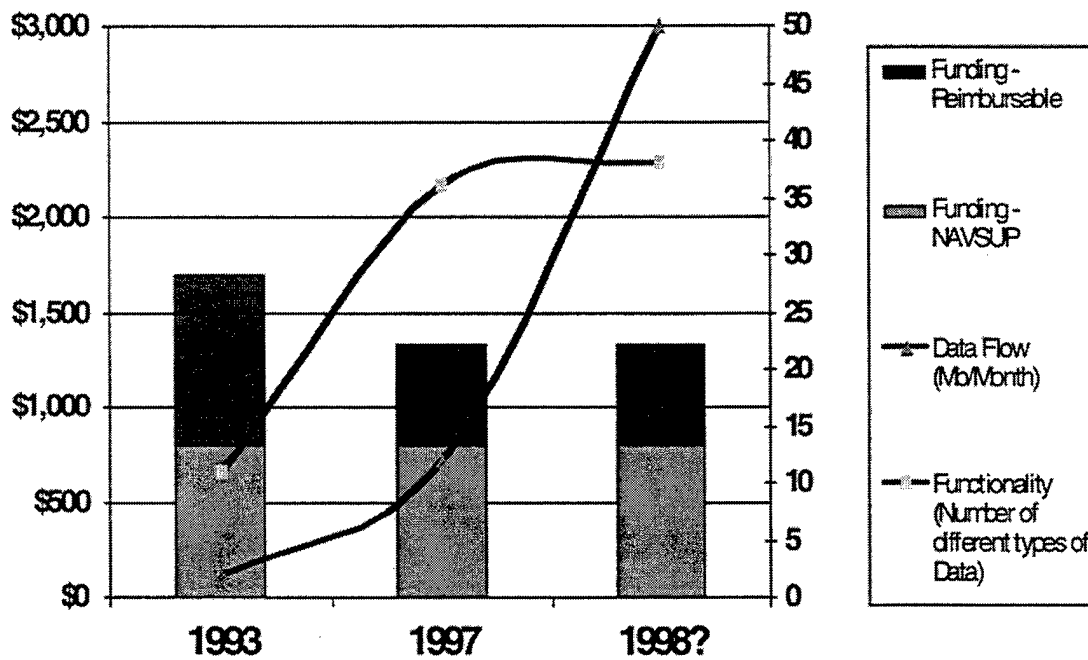

Figure 9 SALTS Functionality vs. Funding and Data Flow

1. Security

All information destined for SALTS users is hidden behind a firewall. A user must have both a valid login name and password to access the system. To date there have been no break-ins by unauthorized personnel. During transmission data is secured using public key encryption through the use of a commercial software product named Secret Agent. Data is encrypted on both upload and download. The use of software encryption

will replace slower STU-III connections. NOC has opened the appropriate ports in their firewall to ensure the Commercial Fleet Communications Package (CFCP) will work properly with WINSALTS customers afloat.

2. Automatic Program Updates

All program updates are electronically transmitted and install automatically as patch files. There is no user involvement and no danger of damaged disks or slow mailings. No site visits are conducted to perform the upgrades and all users are on the same software version. This is extraordinarily beneficial for the users who may not have the expertise to install the upgrade and for customer service. SALTS Central is able to train its help desk on a single version of their product and thus keep manning down to a minimum.

D. FUNDING

With the downward trend in defense spending most programs must fight to maintain adequate investment levels. SALTS, although not centrally funded is also under constant fiscal pressure. Since funding results from two major sources the program manager must focus on both. Large shore activity users must be satisfied with the service, or they will no longer purchase it. NAVSUP funds the primary users, the fleet units, but exhibits reluctance during each funding cycle.

E. COORDINATION WITH NAVSUP

One Touch Supply is a new concept and still developmental program designed by NAVSUP to provide web-based parts ordering system. While this may be a viable and more effective solution for shore based activities, its suitability for underway units is

hindered by the available communications channels. Users cannot afford, either in time or money, to be online for hours.

NAVSUP is currently working to refine its definition of "One Touch" supply and SPAWAR's role is translating these needs into requirements for space system design. While NAVSUP and SPAWAR wrestle with requirements definition (Figure 10) for the next generation of the Supply System, the SALTS office provides the most viable application of current technology. Logistic users want access to the immediate answers provided by web client-server architecture but they also demand batch processing for the majority of logistics information.

In the software marketplace vendors strive to make their programs acceptable to the user. A major hurdle for all software user-interface designers is developing user familiarity and product acceptance.

An integrated system with the benefits of both SALTS familiarity and access to the entire Supply System would be a difficult yet worthwhile feat for the fleet user. As long as this development is handled with checks and balances and a program management approach that incorporates multifaceted, interdisciplinary teams.

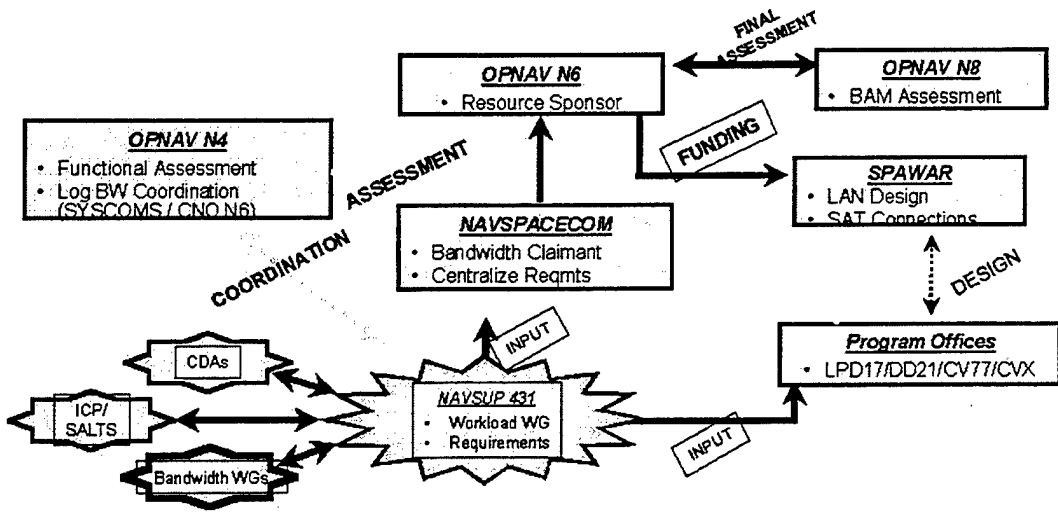

Figure 10 Requirements Generation

VII. COMMERCIAL SATELLITE SYSTEMS

Recent DOD studies project at least a three to five-fold growth in warfighter information requirements that must be satisfied by SATCOM systems in the next decade. This surge in required data transfer capabilities is due largely to the emerging need for push-pull information exchange. [Ref. 10] In an era when our armed forces must be able to sustain two Major Regional Conflicts, communications play a vital role in achieving mission objectives. Communication channels are described using their position within the electromagnetic spectrum. Satellite frequencies are depicted in Table VII.1.

The Fleet UHF Satellite Communication system is the predominate military satellite communication system serving the fleet. This system, however, is operating at full or near full capacity thus restricting the availability of channels. The system architecture is not suitable for modern, high data rate requirements such as video and imagery transmission. In addition, UHF is highly susceptible to jamming. Experience gained from Operations Desert Shield/Storm graphically demonstrated the limitations of the UHF FLTSATCOM system during periods of heavy communication loads or interference. [Ref. 10]

The SHF spectrum provides a highly desirable satellite transmission medium due to characteristics not available in lower operating frequencies. These include wide operating bandwidth to support high data rates, narrow uplink bandwidth, and inherent jam resistance. Operations Desert Shield/Storm reinforced the requirement for SHF SATCOM capability on aircraft carriers and amphibious flagships to satisfy minimum tactical command and control, intelligence, and warfighting communication

requirements. However, a shortfall in Defense Satellite Communication System (DSCS) satellite capacity has been well documented. [Ref. 10]

Military EHF satellite systems provide robust assured low and medium data rate capability to deployable and mobile assets. EHF systems will furnish global coverage, however, jam resistance must be traded for higher data rate capability. Currently, there are no plans to incorporate high data rate capability to EHF SATCOM. [Ref. 10]

Band	Frequency	Advantages	Disadvantage
VHF	30 – 300 MHz	Low power requirements, Mobile	Limited distance, Susceptible to jamming, Crowded spectrum
UHF L,S	300 – 3000 MHz	Greater bandwidth, Small/highly mobile, Mature technology	Susceptible to jamming, Crowded spectrum
SHF C, X, S, Ku, Ka	3 – 30 GHz	Greater bandwidth, Less vulnerable to nuclear blackout	Susceptible to jamming
EHF Ka	30 – 300 GHz	Extensive bandwidth, Jam-resistant, Non-crowded spectrum, Least vulnerable to nuclear blackout	Risky technology, Susceptible to rain attenuation

Table VII.1 Frequency Band Comparisons

Existing and planned military SATCOM initiatives do not fulfill projected requirements; therefore, commercial alternatives have been identified as a cost-effective solution. Their capabilities are leveraged to provide service where military capabilities do not exist. The promise of seamless global real-time voice, fax, data and even broadband multimedia capabilities has the potential to dramatically change the way information is distributed and shared around the globe.

A. SATELLITE SYSTEMS

The initial Operational Requirements Document (ORD) for commercial satellite services was prepared by Chief of Naval Operations (OPNAV), code N6, it documented the need for satellite capacity beyond military capabilities. The Navy commercial satellite communication (COMMERSAT) initiative was then instituted as an ACAT IV acquisition program for the INMARSAT A system. INMARSAT services were procured and fleet units were then outfitted with equipment. At the time, INMARSAT was the only available service provider with global coverage. The Navy negotiated a rate of \$6.25 per minute from ship to shore and \$12.25 per minute ship to ship. At these rates, bills upwards of \$50,000 were not uncommon for small ships with embarked staffs.

SALTS satellite traffic is currently averaging twelve gigabits per month for deployed units, a seemingly low figure. However, this figure represents pure compressed data, there are no associated structures such as web pages. NAVSUP's push for "One Touch Supply" will require a web-based solution, which denotes a significant increase in impending requirements.

To meet an ever-increasing demand, new commercial satellite systems are emerging and deploying new constellations. The three main components of the systems are the space segment, ground segment, and the terminal. The space segment consists of the constellation of satellites, frequencies and orbit. The ground segment is comprised of gateways and the Control Center. The terminal units provide user access to the system.

1. User Terminal

As a key component of any system is the terminal, it can vary in both size and complexity. Size alone has a dramatic impact, particularly on small ships with limited

most space availability. Complexity will dictate installation requirements, another significant impact since there is also a direct correlation to personnel technical capabilities. Terminal size depends on both frequency and power requirements. These issues have led to the terminal becoming the both the cost and fleet integration driver. Removal of old terminals is also a major issue for replacement systems. Thus program managers must evaluate the manpower and funding issues surrounding all aspects of new system initiation. Terminals may fall into three categories based on data throughput rates as follows:

Terminal Classification	Data Rate
Low	600 bps - 64 kbps
Medium	64 Kbps - 1.544 Mbps (T-1)
High	1.544 Mbps (T-1) and higher

Table VII.2 Terminal Classifications

The wide-band terminals operating in the commercial C and Ku bands will provide additional capacity for the transmission of video, imagery, teleconferencing, and multiple simultaneous secure voice connections (Table VII.2). Low data rate terminals will provide narrow band point-to-point voice, facsimile, and data transmission capabilities. The various services and capabilities combined provide the required coverage, protection and capacity that the Navy needs to maintain contact with shore-based commands, deployed units, and joint/allied forces during all phases of operations.

The maintenance and support philosophy will rely on the commercial market, with vendor-supplied spares kits, and modular replacement. Government/Organic Depot capability will not be established in support of COMMERSAT. [Ref. 10]

Protocols define the interactions between communications processes. Their role is to provide compatibility among distinct communications systems. Use of standard protocols ensures cooperative path establishment and open methods of information transfer. Gateways are devices used to connect dissimilar networks through translation of associated protocols. They can also be used to implement data security functions such as firewalls. They may also be owned and operated by either the satellite communications company, or third party service providers. Control Stations provide telemetry and tracking services while also monitoring satellite operational functions.

2. Space Segment

The space segment is divided into categories primarily by orbit height. As the orbit directly effects coverage and latency, its impact on communications is great.

a. Low Earth Orbit (LEO)

LEO satellites possess orbits from 500 to 2000 kilometers (km). Proximity to the earth has both advantages and disadvantages. Low orbit heights create significant drag on the satellite and shortens its life span to an average of three to five years. LEO satellite speeds can reach 7.6 km per second, which demand frequent transmission hand-offs since the satellite travels out of range quickly.

There are advantages to close proximity to the earth as well, such as reduced propagation delays (Table VII.3) and small antenna requirements. These features are complimentary to the desires of telephone and network users who will not tolerate the long signal delays during conversations.

b. Medium Earth Orbit (MEO)

An earth orbit in an altitude roughly midway between the earth and geosynchronous orbit. It falls between between the altitudes of 1,500 and 6,500 kilometers above the earth.

c. Geostationary Orbit

GEOs are positioned at precisely 22,238 miles above the earth's equator allowing them to maintain an orbit that takes exactly twenty-four hours to rotate around the earth. GEO satellite systems are best suited for their missions of high-speed data, television transmission, and other wideband push applications.

Orbit Classification	Orbit Height	Signal Delay
GEO	35,786 Km	252 msec
MEO	10,000-20,000 Km	133 msec
LEO	up to 2,000 Km	5 msec

Table VII.3 Orbit Latencies

Since LEOs are closer to earth, the signal is stronger and smaller terminals can be used. LEOs are also sub-divided into different categories based on frequency: little LEOs (800 MHz), big LEOs (2 GHz), and broadband LEOs (20 to 30 GHz). The inverse relationship between frequency and wavelength dictates that when frequency increases, wavelength decreases and the receiving terminal (whether it's a phone or dish) can be made smaller. [Ref. 11] Size of the antenna is a great concern for ships with limited mast space and weight concerns.

Over the next few years, both GEO and LEO providers intend to develop services in the Ka band where higher frequencies support data rates ranging from 16 Kbps to 1.2 Gbps. Those are theoretical maximums, though; most likely speeds will actually range

between 2 Kbps and 155 Mbps. As these next-generation satellites are launched, new switching capabilities will enable satellites to forward traffic between satellites for delivery to another part of the globe, something they cannot do today.

3. Multiplexing

Communications systems employ various multiplexing methods in order to handle numerous simultaneous signals over the same transmission path. This multiple access technique permits efficient utilization of the system's limited assigned spectrum. A multiple access method is a definition of how the radio spectrum is divided into channels and how channels are allocated to the many users of the system.

a. Time Division Multiple Access (TDMA)

TDMA is a digital multiplexing scheme that takes a slice of spectrum and divides it up into time slots. It then assigns access times to each subchannel at specific, regular intervals. This time slot is allocated whether or not information is being transmitted, although the system can vary the length of time slots. TDMA can accept multiple data rates and sequence them into a higher capacity data stream. [Ref. 12] Only one subscriber at a time is assigned to each time slot, or channel. No other conversations can access this channel until the call is finished

b. Frequency Division Multiple Access (FDMA)

FDMA divides a circuit into several smaller channels by frequency for simultaneous transmission. It allows a system to accept multiple users, sharing the same data path. Because the bandwidth can only be divided into a limited number of channels and increasing the number of channels decreases the bandwidth of each, user support is constrained. [Ref. 12]

c. Code Division Multiple Access (CDMA)

With CDMA, unique digital codes, rather than separate frequencies or channels are assigned to each user. Current systems take a signal at 9600 bits per second (bps) and spread it over a transmitted rate of about 1.23 Megabits per second (Mbps). This spreading occurs through the use of digital codes that are applied to the data bits. The data bits are transmitted along with the signals of all other users in the cell. When the signal is received, the codes are removed from the desired signal, separating the users and returning to the original data rate of 9600 bps. Because of the spread signal it is difficult to jam or interfere with a CDMA signal; it is also very hard to detect. One possible disadvantage is the associated hardware complexity. While this technology has been employed in the cellular phone industry, its use in satellite communications is still immature. Complexity also leads to higher equipment costs.

4. System Characteristics

There are many possible evaluation characteristics feasible for satellite system comparisons. Those chosen for this study are based upon the Capstone Key Performance Parameters in the Capstone Requirements Document and the two practical issues of cost and antenna size. [Ref. 13]

a. Coverage/Availability

Coverage delineates the geographic area encompassed by the satellite's transponders, or footprint. A wider perspective considers accessibility to the transmission path throughout the entire system. In other words, globally accessibility is a key consideration because the commercial focus is on land masses. The Navy's

requirements are decidedly concentrated on the oceans, making system coverage analysis critical to selection of appropriate commercial services.

b. Capacity

The conventional, technical definition of capacity is the data transmission rate over a given channel. As previously discussed, multiplexing allows for more efficient use of the spectrum and enhances a system's ability to provide full capacity to multiple users. Thus the version of multiplexing chosen by a particular architecture directly impacts total system capacity. Information being supplied by commercial providers presents ideal transfer rates, or those achieved with light system loading.

An additional consideration is availability of capacity during times of crisis. While commercial satellite usage has been approved as long as the United States' operations have North Atlantic Treaty Organization (NATO) approval or the United States is not the aggressor, the Navy will compete for system use with the provider's other customers. At the Commercial SATCOM Industry Day, 15 April, 1998, several companies indicated a possibility of providing a certain amount of guaranteed capacity. This of course, would have to be approved by the corporation and there could be difficulties since several of the providers are multi-nation consortiums.

Naval units must be capable of receiving information enroute at sea to perform a wide variety of short-notice missions over a global range of operating areas. Access to commercial satellite capacity permits tailoring of communications over a wide variety of missions and operating areas. This will allow them to deploy with the maximum diversity of SATCOM resources. Commensurate with the unit's size and mission COMMERSAT, with its flexible approach, can be employed to provide supplemental and complimentary communication capacity. Commercial systems are not

however, designed to shift capacity from one zone to another. LEO systems are not in orbit over a point long enough to concentrate capacity and most commercial GEOs do not possess steerable beams.

c. Protection

The COMMERSAT space segment is vulnerable to the same threats as military satellite systems, and within the ground segment antenna and transceivers are also vulnerable. Systems may be jeopardized by electromagnetic threats including jamming, interception, exploitation, high-altitude electromagnetic pulse, and degradation of the communication links. Physical threats include direct and indirect fire weapons, environmental factors, chemical contamination, and nuclear destruction. The physical adversities remain unopposed, and consistent with DOD recommendations for the use of COMMERSAT the systems will not be modified to counter these threats. [Ref. 10]

While DOD's position is not to modify the commercial systems there are those that either offer more secure features or possess resistant technology. As examples, the narrow antenna beamwidths used in COMMERSAT antennas operating in the C and Ku bands provide some downlink jam resistance, and the type of multiplexing also impacts vulnerability. Many corporations are just as concerned about data security as the military. Several providers, whose marketing is aimed at that business sector correspondingly perform encryption of signals. Encryption heightens the confidentiality of information.

Another pillar of secure communications is authentication of the user or prevention of spoofing. While commercial satellite providers have not publicly released detailed information in this arena, they are certainly concentrating on it. With the lessons learned from the cellular phone industry, one can be sure that satellite systems will

employ technology to verify user identities. Corporations can ill afford to let impersonators access to their proprietary information and the military will benefit from measures implemented to prevent user impersonation.

Finally, DOD use of COMMERSAT systems is not intended to provide protected, survivable communication in a hostile environment. Communications requiring such protection will be conducted over MILSAT channels.

d. Access

As discussed within Coverage, military users of commercial systems will have to compete with civilian users, as well as those from other military units. DOD cannot control commercial satellite accessibility. Certain providers do indicate a willingness to allow priority traffic service but such capability would come at a significant price. Therefore, limited control over satellite access may hinder selection of commercial SATCOM services for operationally related communications.

SALTS however, is unconstrained by such demands of assured access due to the nature of its transmissions. If the system provides reasonable accessibility, other factors become more significant.

e. Interoperability

While interoperability in the Capstone Requirements Document centered on satellite use for Joint forces, this study will shift to a focus on operability with open standards. Since the SALTS system is a data transmission program the communications pipe must be compatible with the associated communication standards such as TCP/IP for Internet connections. Compliance with open standards will define the use of the term interoperable.

Another consideration could have been the ability to achieve interoperability between different systems, such that a single terminal could be used. This aspect was considered implausible due to the nature of the emerging technology of the commercial systems. Each of the commercial systems was developed independently and there was no pressure to influence commonality.

B. COMMERCIAL ALTERNATIVES

The Navy and DOD must analyze features, costs, risks, and quality to determine a strategy for incorporation of commercial capabilities into the military environment. Understanding the characteristics of commercial systems can determine their applicability.

1. International Maritime Satellite (INMARSAT) B

The INMARSAT analog system was the initial commercial satellite system selected for providing on demand point-to-point voice and data transfer capability for the Navy. Its global coverage (Figure 11) provided the necessary oceanic footprint to furnish the communication path for ships at sea. Unfortunately, a low user volume of 40,000 to 50,000 subscribers kept service charges high at approximately seven dollars per minute.

[Ref. 14]

The digital follow-on version is now available as INMARSAT-B. It offers lower communication costs, worldwide availability, greater bandwidth, and higher reliability. Services have been expanded to include paging, high-speed data, and video teleconferencing.

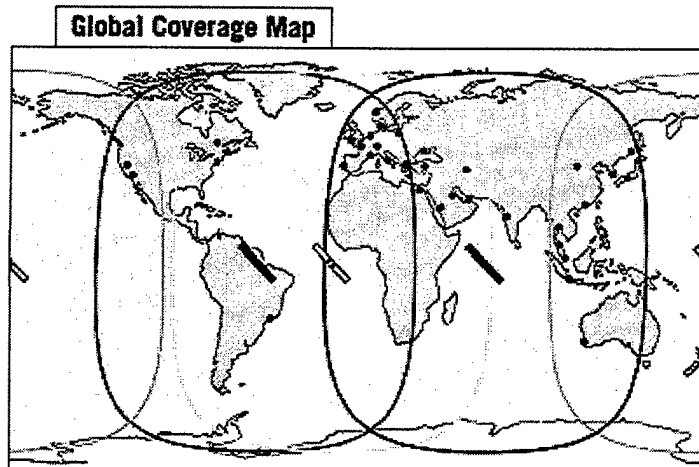

Figure 11 INMARSAT Coverage From Ref. [15]

a. Ground Segment

INMARSAT's ground segment is decomposed into Ship Earth Stations (SES), Land Earth Station (LES), Network Coordination Stations (NCS), and a Network Operations Center in London, Uk. The LES gateways are located throughout the world and are owned by third parties. COMSAT, a US owned corporation owns the four SESs used by the Navy. COMSAT has also laid a fiber backbone connecting each of LESs, allowing Navy users to avoid connections routed through an internationally owned gateway. [Ref. 16]

Calls originating from a ship's SES first generate a request message that is addressed to the nearest gateway, the message is then forwarded to the NCS which assigns a channel in the appropriate satellite's spot beam. The assignment is relayed back to the SES and gateway.

b. Space Segment

It uses an existing constellation of eight fixed geostationary satellites. The satellites do not relay messages between themselves; all packets are routed through

ground stations. Each of the new INMARSAT III satellites uses up to seven spot beams and a single global beam. The number of spot beams is chosen according to traffic demands. The bandwidth can also be dynamically allocated between the beams to distribute traffic. [Ref. 15]

c. Coverage/Availability

Each SES and LES acts as a gateway between the Inmarsat satellites and the terrestrial communications network. The satellites cover approximately 70° North to 70° South latitudes. The systems use of eight satellites offers redundancy should a satellite fail.

d. Capacity

INMARSAT allocates a maximum of five channels for “peak” 64 Kbps data capacity [Ref. 15]. The maximum capacity is approximately 2,400 calls depending on the bandwidth of the individual transmissions. A distinct advantage of the Inmarsat-3 satellites is the ability to concentrate their power on particular areas of high traffic within the footprint.

e. Protection

The INMARSAT system alone offers little protection against jamming, detection or confidentiality. It does however support customer use of encryption devices such as STU-III phones. Additional protection is offered by the COMSAT LES structure.

f. Access

The use of a COMSAT gateway assures Naval access to the system. This is possible because the gateways perform such functions as the TDMA time slot

assignments, call priority establishment, and maintenance of access control tables [Ref. 16].

2. ICO

ICO is a MEO system designed to provide hand-held mobile communications for global customers (Figure 12). Formed under the significant influence of INMARSAT, launches are due to begin late in the first half of 1999. Voice, fax and narrowband data services are scheduled to begin in 2000. The orbital pattern of the ICO constellation is designed for significant coverage overlap, ensuring that usually two but sometimes three and up to four satellites will be in view of a user and a Satellite Access Nodes (SAN) at any time. [Ref. 17] The system will support dual mode terminals that can receive both Global System for Mobile Communications (GSM) cellular and satellite communications.

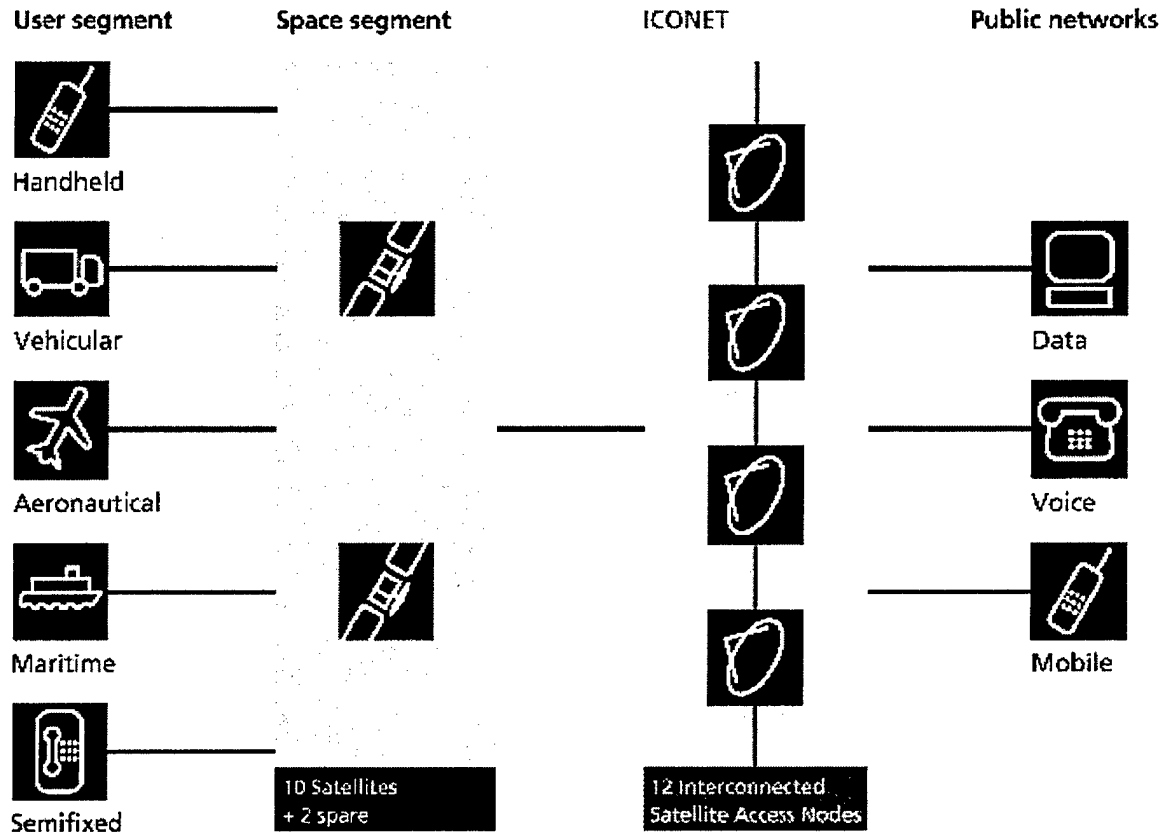

Figure 12 ICO System From Ref. [17]

a. Ground Segment

Twelve SANs will be located around the world and will communicate with the satellites. They will route transmissions to the terrestrial network (ICONET), which is a fiber backbone. The ICONET will carry the traffic to the gateway with PSTN access. This linking of SANs by high-speed cable offers additional control of traffic and provides a means to effectively route calls. The satellites will communicate with the SAN, which will select call routings to ensure the highest possible quality and availability of service to system users. Calls from a mobile terminal will be routed via the satellite constellation and ICONET to the appropriate PSTN gateway. Traffic destined for another mobile satellite subscriber will be routed to the appropriate SAN and then the corresponding satellite. There is no intersatellite routing. [Ref. 18]

b. Space Segment

A constellation of ten MEO satellites in orbit at 10,390 km above the Earth's surface will be arranged in two planes of five satellites each. Each satellite will cover approximately 30 per cent of the Earth's surface. There will also be one spare satellite in each plane. The transmissions will be in the C and S bands with the satellites expected to last twelve years.

The constellation (Figure 13) has been designed to provide global coverage and to maximize path diversity of the system. Path diversity is the simultaneous availability of more than one satellite to a user. Alternative transmission paths decrease the likelihood of dropped calls.

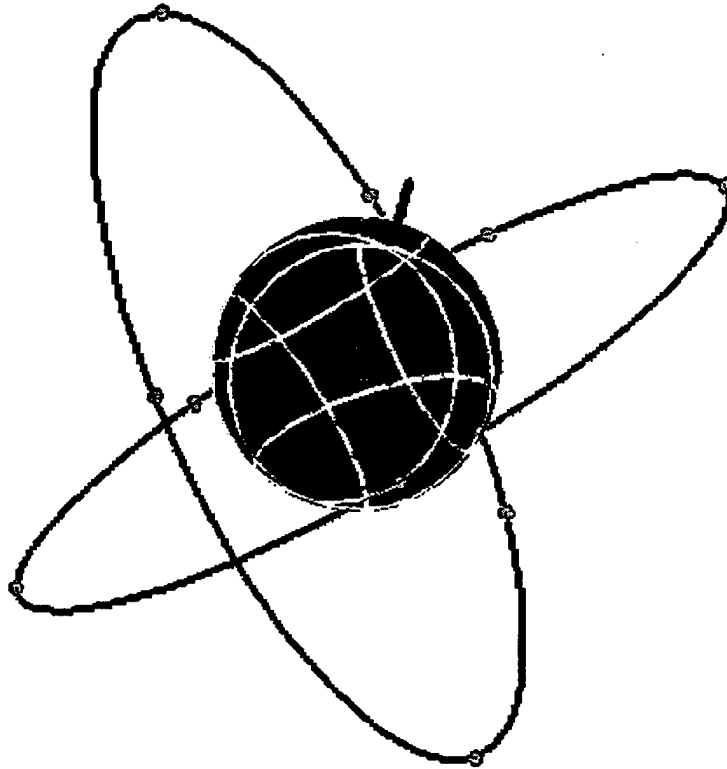

Figure 13 ICO Constellation From Ref. [19]

c. Coverage/Availability

The configuration has been designed to provide coverage of the entire Earth's surface and to maximize the path diversity of the system. Path diversity is the availability of more than one satellite to a user simultaneously. Providing a fully distributed system ensures alternative paths for transmission in case the line of sight from one satellite is obstructed. These features increase the likelihood of uninterrupted calls and provide extremely high availability.

d. Capacity

Each satellite has 750 carriers with six channels per carrier and is thus designed to support at least 4,500 telephone channels using TDMA. [Ref. 17] The complete constellation should support 2,400 million voice minutes per year. [Ref. 14]

e. Protection

ICO will incorporate GSM's user verification processes. This will include authentication of user information and status, as well as location of the user anywhere on the globe. [Ref. 17] An optional feature is Smartcard compatibility that will allow connection of security modules [Ref. 18].

f. Access and Control

With use of the same COMSAT-owned gateway used for INMARSAT ICO will likewise offer the same access security and control [Ref. 18].

g. Interoperability

ICO's intent is to deploy a standards-based system that will be interoperable with both network and telecommunication standards.

3. Orbcomm

As the first operational LEO data system Orbcomm offers messaging and paging services with its network of forty-eight satellites. The system also features global positioning system (GPS) data that can be used for asset management. Instead of terrestrial fixed site relay repeaters to provide worldwide geographic coverage. Small low-power, low-cost subscriber equipment is a primary element of ORBCOMM's business strategy and it is paired with low cost service pricing.

a. Ground Segment

The ground segment, possesses most of the "intelligence" of the ORBCOMM System. It is composed of Gateway Control Centers (GCC) located in a territory that is licensed to use the System. Interfaces to the GCC enable reliable, efficient and cost effective integration of the ORBCOMM System into existing or new customer MIS systems. Gateway Earth Station (GES) link the ground segment with the space segment and will be in multiple locations worldwide. The GESs provide the following functions:

- Acquire and track satellites based on orbital information from the GCC
- Transmit and receive transmissions from the satellites
- Transmit and receive transmissions from the GCC or NCC
- Monitor status of local GES hardware/software
- Monitor the system level performance of the satellite "connected" to the GCC or NCC

The Network Control Center (NCC) is responsible for managing the network elements and the US gateways. It provides network management of ORBCOMM's satellite constellation.

b. Space Segment

The main function of ORBCOMM's satellite network (Figure 14) is to complete the link between the user's terminal and the switching capability at the gateway. The satellites are packet routers ideally suited to directing small data packets from remote sites and relaying them through a tracking Earth station and then to a GCC.

A message sent from an SC unit is received at the satellite and relayed down to a GES that connects the ground system with the satellites. The GES then relays the message via satellite link or dedicated terrestrial line to the NCC. The NCC routes the

message to the final addressee via e-mail, dedicated telephone line or facsimile.

Messages and data sent to an SC can be initiated from any computer using common e-mail systems including the Internet. Trial messages have been averaging thirty seconds from source to destination. [Ref. 20]

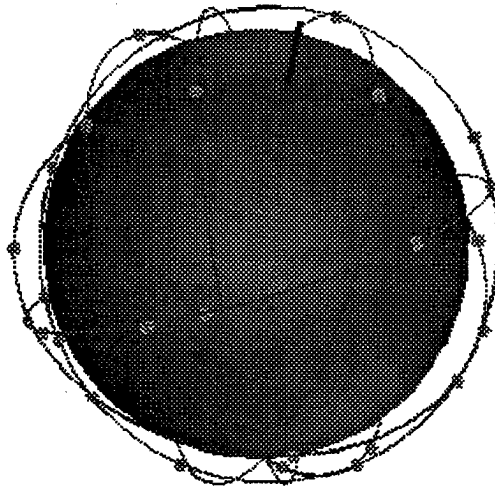

Figure 14 Orbcomm Constellation From Ref. [19]

c. Coverage/Availability

Initial reliability has been 99.99% although that figure is jeopardized by Orbcomm's decision to position its spares on the ground, rather than in orbit [Ref. 21]. Another drawback for Naval use is the type of ocean service. If a user is unable to access a satellite the system reverts to a store and forward methodology. [Ref. 22]

In March, 1999 the FCC granted a modified its license to allow for more efficient, higher data rate subscriber downlinks. In addition, the FCC authorized an increase in the orbital altitude of the non-high inclination satellites in the ORBCOMM constellation from 775 km to 825 km. These modifications will allow ORBCOMM to

improve availability in the higher latitudes, including Alaska, Northern Canada, Northern Europe and Russia, while increasing capacity in the temperate zones. [Ref. 23]

d. Capacity

Orbcomm uses TDMA to handle subscribers within the same cell. The maximum data rate is 4800 bps on the downlink with a 9600 bps uplink [Ref. 22]. The system's capacity is one million messages per hour. However, each message is limited to two thousand bytes.

e. Interoperability

The GCC provides switching capabilities to link mobile Subscriber Communicator (SC) with terrestrial-based customer systems via standard communications modes including X.400, X.25, leased line, dial-up modem, public or private data networks, and e-mail networks including the Internet.

4. Globalstar

Globalstar was established as an international partnership with major members from the United States, Japan, France, and service providers around the globe. Globalstar's focus is on cellular extension, a satellite solution that extends beyond the user's cellular provider. The equipment will be dual mode, capable of receiving both Global System Mobile (GSM) communications and Globalstar's. It is both a voice and data transfer solution.

As satellites are constantly moving in and out of view, they will be seamlessly added to and removed from the calls in progress, thereby reducing the risk of call interruption. Soft hand-off is a key feature of Globalstar that works hand-in-hand with path diversity. It enables a Globalstar user to be connected to as many as three satellites

simultaneously. Path Diversity is a method of signal reception that permits the combining of multiple signals of varying power strengths into a single coherent signal. As satellites are moving in and out of view, they will be added to and removed from the calls in progress, in an attempt to reduce the risk of call interruption. [Ref. 24]

a. Earth Segment

Globalstar's satellites do not directly connect one Globalstar user to another. Rather, they relay communications between the user and a gateway, using a satellite relay only when Public Switch Telephone Network (PSTN) access is unavailable. The party being called will be connected with the gateway through the PSTN or back through a satellite if the party is another Globalstar user.

The gateways are not owned Globalstar, but rather by commercial providers. Gateways can be shared by multiple service providers who then share the investment expenses. Globalstar may also be willing to permit a military gateway. However, while users are deployed overseas, their transmissions may be routed through the nearest local gateway.

b. Space Segment

Currently Globalstar has launched twenty of its fifty-two satellites. This will provide for a final constellation (Figure 15) of forty-eight satellites with the remaining four to orbit as spares. Launches are scheduled to continue until the full Globalstar constellation is complete. The company plans to initiate service in the third quarter of 1999, using an initial thirty-two satellite constellation. The satellites in the first-generation constellation are designed to operate at full performance for a minimum of seven and one half years. There is no on-board processing or crosslinks. Each satellite

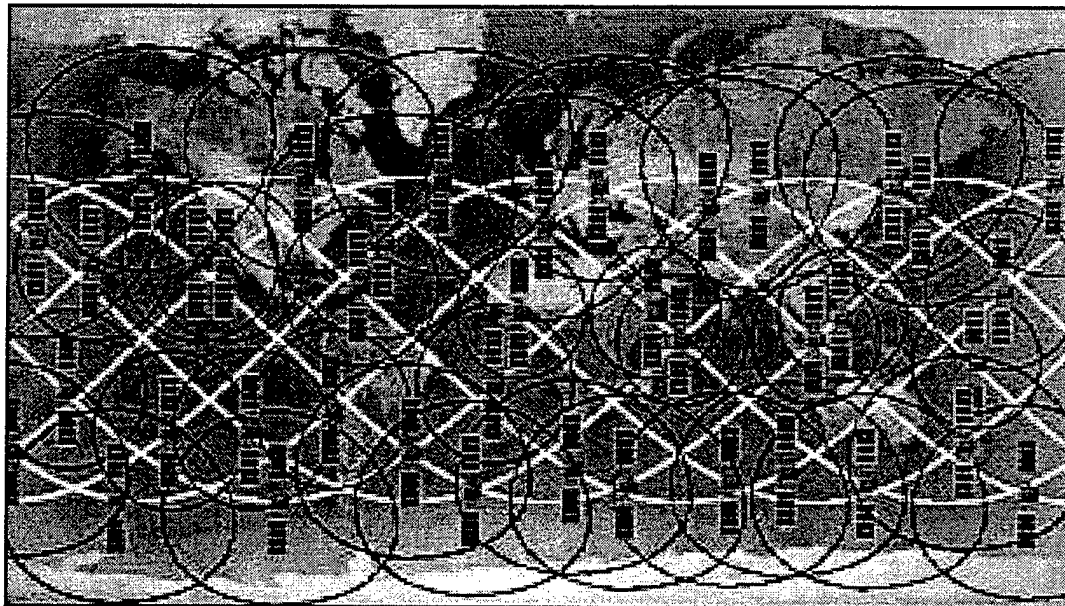

Figure 16 Globalstar Satellite Coverage Areas From Ref. [24]

d. Capacity

Globalstar has adapted a combination of FDMA with CDMA and spread spectrum modulation that enables it to support multiple users simultaneously and to share its allocated frequencies with other CDMA systems. Globalstar believes that CDMA, combined with the path diversity offered by multiple satellites, will result in higher call quality and fewer dropped calls when handing off between satellites. The system should be able to achieve approximately 2800 simultaneous calls. [Ref. 24]

e. Access

Satellite Operations Control Centers (SOCC) will track and control the satellite constellation using command and telemetry units located in various gateways around the world. Ground Operations Control Centers (GOCC) are responsible for planning and controlling satellite utilization by gateway terminals and for coordinating

this utilization with the Satellite Operations Control Center (SOCC). The gateways then process real time traffic within these assigned resources.

The gateway stations are the interconnection points between the satellite constellation and land-based telecommunications networks. Each gateway tracks the satellites orbiting in their view. Each nation with at least one gateway within its borders will have complete control over system access by users within its territory. Full global land-based coverage of virtually all areas of the globe can be achieved with fewer than sixty gateways.

Globalstar will build thirty-eight gateways to be installed around the world. These should be ready when service begins in the third quarter of 1999. Tri-mode handsets that will be able to switch automatically from terrestrial cellular analog or digital cellular networks to the Globalstar satellite network, thus allowing users to make or receive calls outside of cellular coverage areas.

f. Protection

All links with the satellites are commercially encrypted. The use of CDMA and spread spectrum modulation also offer protection through the difficulty in signal isolation and detection. The system also requires a fire-wall to ensure security between service providers sharing a gateway. [Ref. 24]

g. Interoperability

The Globalstar system integrates with existing telephone communications infrastructures such as T1 and ISDN using standard interfaces to existing PSTN.

5. Teledesic

Teledesic's aim is to build a global, broadband system to provide affordable, worldwide, fiber-like access to telecommunications services such as computer networking, broadband Internet access, high-quality voice and other digital data needs. The goal will be to provide guaranteed end-to-end quality of service to meet broadband needs. [Ref. 25]

a. Ground Segment

Teledesic Network ground segment consists of terminals, network gateways and network operations and control systems. Terminals are the edge of the Teledesic Network and provide the interface both between the satellite network and the terrestrial end-users and networks. They perform the translation between the Teledesic Network's internal protocols and the standard protocols of the terrestrial world, thus isolating the satellite-based core network from complexity and change.

Teledesic terminals communicate directly with the satellite network and support a wide range of data rates. The terminals also interface with a wide range of standard network protocols, including IP, ISDN, ATM and others. Although optimized for service to fixed-site terminals, the Teledesic Network is able to serve transportable and mobile terminals, such as those for maritime and aviation applications.

b. Space Segment

The space segment or satellite-based switching network provides the communication links among terminals. To implement this network Teledesic intends to use a constellation of 288 interlinked LEO satellites (Figure 17). The topology of this

LEO-based network is dynamic so it must continually adapt to these changing conditions to achieve the optimal connections.

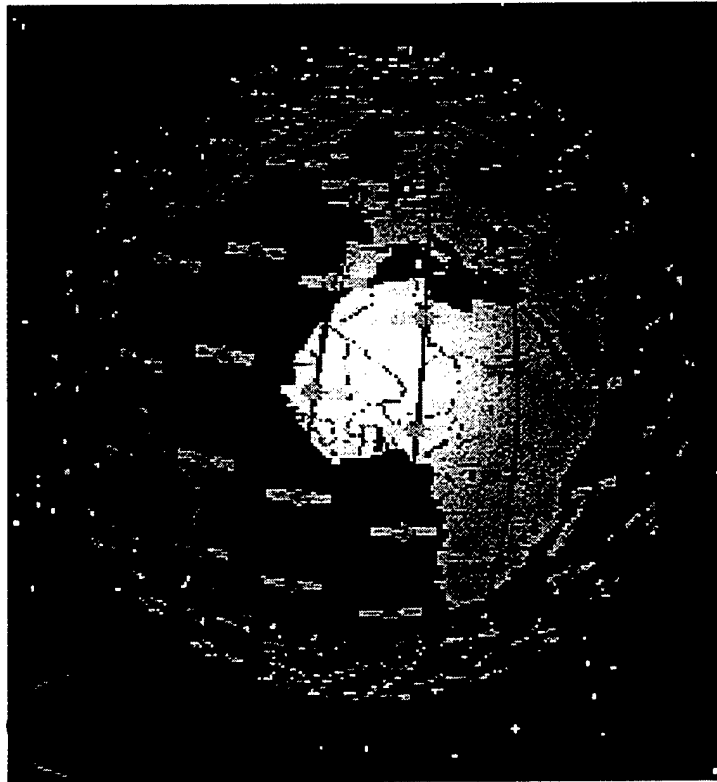

Figure 17 Teledesic Constellation From Ref. [25]

c. Coverage/Availability

Overlapping coverage areas plus the use of in-orbit spares permits the rapid repair of the network whenever a satellite failure occurs. Essentially, Teledesic is attempting to build reliability into the system in order to eliminate vulnerability to the failure of a single satellite.

The Teledesic Network uses an Earth-fixed cell design to minimize the hand-off problem associated with use of its large number of satellites. The Teledesic system maps the Earth's surface into a fixed grid of approximately 20,000 "supercells," each consisting of nine cells. Each supercell is a square 160 km on each side. Supercells

are arranged in bands parallel to the Equator. There are approximately 250 supercells in the band at the Equator, and the number per band decreases with increasing latitude. [Ref. 25]

A satellite footprint encompasses a maximum of 64 supercells, or 576 cells. The actual number of cells a satellite is responsible for varies with its orbital position and the distance from adjacent satellites. In general, the satellite closest to the center of a supercell has coverage responsibility. As a satellite passes overhead beam steering compensates for the satellite's motion as well as the Earth's rotation. [Ref. 25]

d. Capacity

Most users will have two-way connections that provide up to 64 Mbps on the downlink and up to 2 Mbps on the uplink. Broadband terminals will offer 64 Mbps of full duplex capacity. The smaller cells with a single beam will allow Teledesic to achieve a high capacity density. The system is also designed to handle ten times the volume if surge capacity is required.

e. Access

Channel resources including frequencies and time slots are managed by the "serving" satellite. The multiple access scheme is implemented within the terminal, and the satellite serving the cell manages the sharing of channel resources among terminals. The combination of Earth-fixed cells and multiple access methods results in very efficient use of spectrum. The network also supports bandwidth-on-demand, allowing a user to request and release capacity as needed. Service plans will also include priority service classes to be negotiated with the user's contract.

f. Protection

Teledesic features both uplink and downlink encryption. The constellation architecture also inherently provides additional protective features. The sophisticated techniques and capability required to jam all 288 satellites (or even a significant portion of them) would be difficult if not impossible to achieve given their short time within view. Additionally, the probability that enough traffic could be generated to flood the system and cause congestion is minimal, due to the system's intersatellite adaptive routing techniques and high bandwidth. Thus Teledesic, will provide natural resistance to jamming attempts, protection for data traveling over its network and barriers to message flooding.

g. Interoperability

The system is designed for compatibility with all applications that are based on current and future protocols, i.e., TCP/IP, IPv6. Teledesic's aim is to provide an extension to an existing Local Area Network (LAN).

C. COMMERSAT COMPARISON

Table VII.4 provides a comparison of key characteristics by system. LEO satellite systems offer significant advantages over GEO systems for signal delivery. These advantages result from an orbit selection that enhances the quality of services to low-power mobile user equipment. The latency effects inherent in GEO systems produce the echo effect heard in voice transmissions. Geostationary satellite communications systems also require changes to meet terrestrial network standards and protocols to accommodate their inherent high latency. This problem is compounded because many real time applications also fail with the half-second delays and network protocols such as

TCP/IP also fail. Hardware equipment is also bulky and expensive, consisting of directional antennas, which must point at a satellite and below deck terminals the size of a video recorder.

Since there are fewer, wider coverage satellites another drawback to GEOs is their susceptibility to single points of failure. GEO systems also require expensive end-user equipment with large power sources to reach the satellites and expensive per-minute transmission charges. Signal's routed through a LEO system can be integrated transparently with telephone or network infrastructures.

One advantage of remaining with INMARSAT is that the Navy is one of COMSAT's largest customers, and COMSAT is INMARSAT's largest shareholder. This would ensure the service's needs were considered during business decisions. Another is the INMARSAT-3 satellite's ability to handle heavy traffic in a specific region, a capability not offered by the LEO systems. However, the system is largely inefficient since a ship to ship call requires at least one gateway routing and two satellite hops. In a GEO orbit additional hops quickly compound the time delay and correspondingly the cost also rises dramatically.

Orbcomm's simple structure and thus low cost equipment offer limited yet useful services. The integration of Orbcomm transmission into SALTS would be feasible, and the system's extremely low service charges make it an attractive yet limited option. Its most likely application will be container tracking and personal paging due to the narrow bandwidth.

The Globalstar ground network is not as extensive as ICO's and it will instead route all calls through public networks. Globalstar's view is that their system will

maximize the use of existing, low-cost communications services. ICO is hoping their network of self-owned gateways will keep system costs low and that it will furnish extra reliability and call-handling capacity for ICO's terrestrial infrastructure. Teledesic, in its guarantee of quality of service, also proposes performance of their own routing vice the use of public networks.

If a satellite fails, the LEO systems Globalstar, and Teledesic will be remain able to provide capacity, as redundancy is built into the architecture of their satellite constellations. By contrast, INMARSAT as a GEO system would suffer an entire regional system outage if a satellite failed. The outage would last until one of the older INMARSAT-2's acting as spares could be brought on-line. Orbcomm, with its spares on the ground will actually have to coordinate a satellite launch before it is able to restore complete services.

In the realm of protection, commercial systems are susceptible to electronic warfare measures such as jamming and message attacks. The system's specific architecture however, may mitigate the effects of an attack through use of CDMA or dynamic routing. Globalstar and Teledesic offer data protection through the use of encryption. While INMARSAT is not encrypted it does permit the use of STU-III connections. ICO in turn allows use of smartcards. Orbcomm, in keeping with its low cost strategy does not offer encryption. SALTS also encrypts its own transmissions.

The DOD goal of true interoperability is currently unachievable with commercial, proprietary systems. While users on different systems can certainly communicate with each other, they would need different terminal equipment. Since all of the systems in this analysis are compliant with standard protocols this issue is one of logistics.

	INMARSAT	ICO	ORBCOM	Teledesic	Globalstar
Full Service	In Service	Aug-00	In Service	2003	Dec-99
Orbit	GEO	MEO	LEO	LEO	LEO
# Satellites	8 (1 Spare)	10 (2 Spare)	48	300(12 Spares)	56 (4 Spare)
Coverage	Polar Gaps	Global	70N to 70S	72N to 72S	72N to 72S
Lifespan Yrs	15	12	5	10	7.5
Terminal Cost		\$1,000	\$250-1,000	\$1,500	\$1,000
Cost per Min	\$29,200/mth per channel	\$1.50	~\$0.75	Competitive (TBD)	\$0.30
Service Charge	N/A	\$25.00	Various	TBD	\$23.60
Data Rate	9.6-64 Kbps	9.6Kbps	2.4 Kbits	2.05-64 Mbps	9.6 Kbps
Encryption	No	TBD	No	Yes	Yes
Antenna Size	135 by 124 cm (antenna housing) 41x15x25 cm (below deck equip)	Handheld or Terminal	Handheld	Various: 28 cm to 60 cm	Handheld
Access Mode	TDMA	TDMA & FDMA	TDMA	ATDMA & FDMA	FDM & CDMA
Band	L, C	L	VHF	Ka	L
Frequencies	1630 – 1660	1980 – 2010	148 and 150	28.6 – 29.1	1610 – 1626.5
Uplink [Ref. 26]	6430 – 6450 MHz	MHz	MHz	GHz	MHz
Downlink [Ref. 26]	1530 – 1560 3600 – 3630 MHz	2170 – 2200 MHz	137 – 138 MHz	18.8 – 19.3 GHz	2483.5 - 2500 MHz

Table VII.4 System Comparison

THIS PAGE INTENTIONALLY LEFT BLANK

VIII. CONCLUSION

With the end of the Cold War and the advent of budgetary limitations, DOD's logistics systems must now support a smaller, highly mobile, high-technology force with processes that are as efficient as possible. Those processes must align with the goal to provide basic hardware and repair parts to keep weapon systems combat-ready.

We are witnessing the advent of a new era of commercial satellite communications, with expanding capacity and interlinked LEO satellite constellations. New features such as packet switching and dynamic routing between source and destination make analysis of commercial satellite systems worthwhile. Systems studies and ensuing long-term service agreements will lead to great benefits for the mobile logistics communicator whose email, high-speed web browsing and file transfer demands are increasing exponentially.

A. PROGRAM MANAGEMENT

SALTS provides timely access to information that directly impacts fleet readiness. This information availability is the key to force sustainment. Enhanced inventory utilization is promoted through increased asset visibility and in-transit status. Improved funds management is facilitated through timelier financial reporting. In an increasingly complex environment SALTS offers the single best alternative for ships and remote users. The system has evolved and kept pace with customer requirements, becoming the single point of entry for multiple databases and services. The ease of use, combined with file traceability and system reliability brings remote access to logistic information to operational units when they need it.

Forced into an arena comprised of multi-million dollar communications programs SALTS finds itself alone and unlike any other Department of Defense acquisition program. There is no formal recognition of the system as a program and it lacks any official categorization such as an acquisition category (ACAT). The structured and regulated phases of program management offer visibility and direction for systems development. For SALTS there needs to be an implementation of a program structure that provides a balance between program control and the current unstructured management.

While SALTS' low visibility has allowed unencumbered development it has also fostered a lack of systems command level appreciation and minimal financial support. In an era of austere funding the SALTS success should be studied as a model for rapid non-tactical software development. It is important for NAVSUP and SPAWAR to consider the option that One Touch Supply build upon, not replace SALTS. SALTS provides considerable non-logistics information.

NAVSUP customers would benefit from increased SYSCOM involvement in the program that directly impacts fleet logistic operations. Incorporation of One Touch under the SALTS umbrella will immediately offer user acceptance and draw upon the corporate knowledge possessed by SALTS personnel. The checks and balances provided by a tailored program management strategy that incorporates a suitable acquisition strategy and use of the SEI's CMM, could compliment the innovation and dedication already demonstrated by the SALTS team.

NAVICP is not the most appropriate command for an acquisition program. While it has provided a haven for quick development and rapid prototyping, program

management is not its intended role. Only at the SYSCOM level can the suitable support and guidance be found. With equivalent positions the program can liaison with SPAWAR satellite programs to ensure logistic/administrative data transmission needs are met. The author feels NAVSUP must increase its commitment towards improving its Information Technology management infrastructure. This should include promotion opportunities, program staffing and funding, and graduate school attendance. The logistics business, centers and revolves around information therefore the corresponding management expertise must be a core competency.

Exploitation of the most reliable and expeditious communications channels available is necessary to adequately and efficiently support the warfighter. SALTS has achieved drastic reductions in information cycle times through the foresight of a few IT knowledgeable leaders.

COMMERSAT requirements generation has traditionally overlooked operational logistic needs. This has transpired from a lack of understanding and thus limited involvement by NAVSUP and N4 during MNS and ORD development. Relinquishing control and responsibility for advancing technology will lead down a non-recoverable path.

B. COMMERSAT

As commercial space takes the lead in technological development, the military must closely monitor the evolution with aims at exploiting its advantages. Commercial affordability and the exponential growth in bandwidth demand are both pushing towards a broadband solution. Current Internet economic trends also indicate that service quality will improve as it simultaneously becomes less expensive. These trends further dictate

that manufacturers will obsolete their own products, mandating the need to remain abreast of the rapidly changing technology.

Technology reviews that coincide with industry developments should correspondingly be integrated into program planning. As the pace of obsolescence increases, close ties with commercial service providers will provide opportunities to plan upgrades in system capabilities.

Current information indicates that broadband COMMERSAT access will be established by 2002. Inclusion of commercial services into planned military requirements is well on the way. Both OPNAV N6 and SPAWAR are evaluating systems as they develop. Careful consideration of primary system characteristics, including coverage/availability, capacity, access, protection, and interoperability – must be balanced off each other to arrive at the desired level of system performance.

C. RECOMMENDATIONS

Each of the systems is slightly different, but several may meet the Navy's requirements. It is the author's opinion that ICO or Globalstar will offer the most viable systems within the next two to three years. Comparatively large deployable antenna size and greater latency figures hinder the INMARSAT system. When Teledesic deploys, and if its goals are achieved it will become the Navy's most powerful option.

The author feels that the smaller antenna sizes associated with the ICO and Globalstar systems as well as their lower subscriber costs warrant immediate consideration for Naval implementation. Orbcomm's limited capabilities and lack of protection eliminate it as a useful full-service communications channel.

D. RECOMMENDATIONS FOR FURTHER STUDY

Future research into the areas of distributed databases, software distribution, multimedia email, and supply chain information management would be valuable.

Another area is a new program in which OPNAV N6 is working with COMSAT on an inclined orbit or "WabbleSat" program that would provide inexpensive, broadband and dedicated satellite access. [Ref. 27] Investigation into the characteristics and applications of this system could be beneficial.

Orbcomm and its terminal hardware partner are developing exciting new methods of tracking and monitoring items in remote areas. Initial research has produced, small and inexpensive devices that utilize Orbcomm's GPS feed. This would appear to be a useful technology for the logistics community, and container management in particular.

THIS PAGE INTENTIONALLY LEFT BLANK

LIST OF REFERENCES

- 1 General Accounting Office, AIMD-96-64, *Information Technology Investment: Agencies Can Improve Performance, Reduce Costs, and Minimize Risks*, p.2, 30 September 1996.
- 2 General Accounting Office, GAO/NSIAD-97-28, *Logistics Planning: Opportunities for Enhancing DOD's Logistics Strategic Plan*, pp.2-3, 18 December 1996.
- 3 General Accounting Office, AIMD-97-6, *Defense IRM: Strategy Needed for Logistics Information Technology Improvement Efforts*, p. 3, 14 November 1996.
- 4 Department of Defense, Secretary of the Navy, *Forward from the Sea*, pp. 1-3, 1994.
- 5 Department of Defense, Defense Systems Management College, *Introduction to Defense Acquisition Management*, pp. 5-16, Defense Systems Management College Press, June 1996.
- 6 Department of Defense Directive 5000.2R, *Mandatory Procedures for MDAPs and MAIS Acquisition Programs*, 23 March 1998.
- 7 Defense Systems Management College, *Teaching Note Concept Exploration Phase*, G.J.Hagan, pp.1-3, 18 Nov 1998.
- 8 Department of Defense Directive 5000.1, *Defense Acquisition*, 15 Mar 96.
- 9 Software Engineering Institute, "Capability Maturity Model", [<http://www.sei.cmu.edu/activities/cmm/>]. May 1999.
- 10 Department of Defense, Chief of Naval Operations N6, *Commercial Satellite Communication Operational Requirements Document*, pp. 3-5, January 1999.
- 11 Gareiss, Robin, "Satellite Services: Down to Earth and Ready for Business", [<http://www.data.com/roundups/earth.html>]. December 1997.
- 12 Department of Defense, C4ISR Handbook for Integrated Planning, pp. 2-46, 2-82, 6-60, 17 April 1998.
- 13 US Space Command, *Advanced Military Satellite Communications Capstone Requirements Document*, 1998.
- 14 Mehrotra, Asha, *GSM Systems Engineering*, 1st ed., pp. 403-418, Artech House Inc., 1996.
- 15 Inmarsat, "The INMARSAT System", [<http://www.inmarsat.org/about2/index.html>]. June 1999.
- 16 Stone, C. R., *Integration of Commercial Mobile Satellite Services into Naval Communications*, Masters Thesis, Naval Post graduate School, Monterey, California, September 1997.
- 17 ICO, "The Space Segment", [<http://www.ico.com/system>]. June 1999.
- 18 Kakavas, I., *The Applications in Military Communication of Low and Medium Earth Orbit Commercial Satellite Systems*, Master's Thesis, Naval Postgraduate School, Monterey, CA, September 1997.
- 19 Wood, Lloyd, "Lloyd's Satellite Constellations", [<http://www.ee.surrey.ac.uk/Personal/L.Wood/constellations/orbcomm.html>]. June 1999.
- 20 CNN, "Orbcomm Launches Full Commercial Sat Data Service" [<http://www.cnnfn.com/digitaljam/newsbytes/122263.html>]. December 1998.

- 21 Orbital Communications, "Orbcomm News", [<http://www.orbcomm.com>]. May 1999.
- 22 EMail from Tandler, John, Orbital Communications, to author, 2 June 1999.
- 23 Florida Today Space Online, "Orbcomm Authorized by FCC", [<http://www.flatoday.com/space/explore/stories/1998/042298d.htm>]. 22 April 1999.
- 24 Globalstar, "System Description", [<http://www.globalstar.com/tech/system/>]. June 1999.
- 25 Teledesic, "Technical Overview of the Teledesic Network", [<http://www.teledesic.com/tech/details.html>]. June 1999.
- 26 NRAO, "Satellite Constellation Survey", [<http://www.nrao.edu>]. May 1999.
- 27 Interview between Commander Celsey, USN, OPNAV N6 and the author, March 1999.

INITIAL DISTRIBUTION LIST

1. Defense Technical Information Center 2
8725 John J. Kingman Road, Ste 0944
Fort Belvoir, VA 22060-6218
2. Dudley Knox Library 2
Naval Postgraduate School
411 Dyer Road
Monterey, CA 93943-5101
3. Professor John Osmundson, Code CC/OS 1
Naval Postgraduate School
Monterey, CA 93943
4. Douglas Brinkley, Code SM/Bi 1
Naval Postgraduate School
Monterey, CA 93943
5. LCDR Ellen E. Roberts 1
4406 South Pershing CT
Arlington, VA 22206