

**DOES THE U. S. ARMY STILL NEED A
MILITARY INTELLIGENCE BATTALION
COMMANDER AND A G2 IN A HEAVY
DIVISION?**

**A MONOGRAPH
BY
Major David L. Ward
United States Air Force**

19990804 071

**School of Advanced Military Studies
United States Army Command and General Staff
College
Fort Leavenworth, Kansas**

First Term AY 98-99

Approved for Public Release Distribution is Unlimited

DTIC QUALITY INSPECTED 2

REPORT DOCUMENTATION PAGE

Form Approved
OMB No. 0704-0188

Public reporting burden for this collection of information is estimated to average 1 hour per response, including the time for reviewing instructions, searching existing data sources, gathering and maintaining the data needed, and completing and reviewing the collection of information. Send comments regarding this burden estimate or any other aspect of this collection of information, including suggestions for reducing this burden, to Washington Headquarters Services, Directorate for Information Operations and Reports, 1215 Jefferson Davis Highway, Suite 1204, Arlington, VA 22202-4302, and to the Office of Management and Budget, Paperwork Reduction Project (0704-0188), Washington, DC 20503.

1. AGENCY USE ONLY <i>(Leave blank)</i>	2. REPORT DATE 17 December 1998	3. REPORT TYPE AND DATES COVERED Monograph	
4. TITLE AND SUBTITLE DOES THE U.S. ARMY STILL NEED A MILITARY INTELLIGENCE BATTALION COMMANDER AND A G2 IN A HEAVY DIVISION		5. FUNDING NUMBERS	
6. AUTHOR(S) DAVID L WARD		8. PERFORMING ORGANIZATION REPORT NUMBER	
7. PERFORMING ORGANIZATION NAME(S) AND ADDRESS(ES) School of Advanced Military Studies Command and General Staff College Fort Leavenworth, Kansas 66027		10. SPONSORING / MONITORING AGENCY REPORT NUMBER	
9. SPONSORING / MONITORING AGENCY NAME(S) AND ADDRESS(ES) Command and General Staff College Fort Leavenworth, Kansas 66027		11. SUPPLEMENTARY NOTES	
12a. DISTRIBUTION / AVAILABILITY STATEMENT APPROVED FOR PUBLIC RELEASE DISTRIBUTION UNLIMITED.		12b. DISTRIBUTION CODE	
13. ABSTRACT <i>(Maximum 200 words)</i> SEE ATTACHED			
14. SUBJECT TERMS G2, MILITARY INTELLIGENCE, MI BN Commander, MI Architecture, Intelligence System			15. NUMBER OF PAGES 63
17. SECURITY CLASSIFICATION OF REPORT UNCLASSIFIED			16. PRICE CODE
18. SECURITY CLASSIFICATION OF THIS PAGE UNCLASSIFIED	19. SECURITY CLASSIFICATION OF ABSTRACT UNCLASSIFIED	20. LIMITATION OF ABSTRACT UNLIMITED	

SCHOOL OF ADVANCED MILITARY STUDIES

MONOGRAPH APPROVAL

Major David L. Ward

Title of Monograph: *Does the U.S. Army Still Need a Military Intelligence Battalion
Commander and a G2 in a Heavy Division?*

Approved by:



COL Joseph Bolick, MA, MMAS Monograph Director

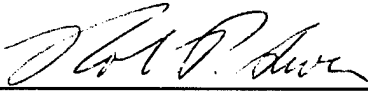

LTC Robin P. Swan, MMAS Director, School of Advanced
Military Studies

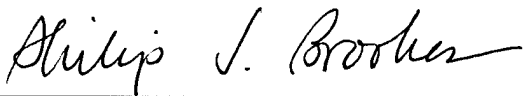

Philip J. Brookes, Ph.D. Director, Graduate Degree
Program

Accepted this 16th Day of December 1998

Abstract

DOES THE U.S. ARMY STILL NEED A MILITARY INTELLIGENCE BATTALION COMMANDER AND A G2 IN A HEAVY DIVISION? by MAJ David L. Ward, USA, 63 pages.

The formation of the MI battalion in a U.S. Army heavy division brought a Military Intelligence commander of the same rank as the G2 into existence. The existence of two Military Intelligence lieutenant colonels in a heavy division has caused a number of problems that have not been adequately addressed by doctrine. None of the other battlefield operating systems have a battalion commander and staff officer of the same rank whose responsibilities are so intertwined. This paper examines whether a heavy division still requires a G2 and a MI battalion commander.

Doctrinal guidance concerning the roles and functions of the G2 and MI battalion commander is vague and contradictory. This paper shows the disconnects and often confusing definitions used. The terms intelligence system and intelligence architecture which are often used synonymously and incorrectly in Military Intelligence Field Manuals are discussed and defined.

This paper examines four options in structure and roles for the G2 and MI battalion commander. The obvious question is whether or not one individual can manage the intelligence system and should he be either a commander or a staff officer. Should MI create a Division Intelligence Coordinator (DIVINT) position modeled along the Fire Support Coordinator (FSCOORD) position in DIVARTY? Or with the increase in technology and connectivity, does the heavy division still require an MI battalion? Can the G2 manage the intelligence system with the assets assigned to the brigades? If both are still required, what is the best structure and accompanying roles and functions? Other than the current structure, a final alternative is to modify the current structure to leverage the MI battalion commander and to clearly define the roles and functions of the G2 and MI battalion commander.

The four options are evaluated on the basis of better intelligence, practicality, training and unity of command and purpose. The paper concludes by determining that the heavy division does require a G2 and MI battalion commander but their roles should be modified for a more efficient intelligence architecture and intelligence system. These new roles and functions along with structural changes are discussed.

Table of Contents

I. INTRODUCTION	1
INTRODUCTION	1
BACKGROUND	4
THE INTELLIGENCE SYSTEM AND ARCHITECTURE	5
II. CRITERIA AND METHODOLOGY.....	10
CRITERIA.....	10
METHODOLOGY	11
III. PERSONNEL, ROLES AND FUNCTIONS	13
ACE, G2 AND MI PERSONNEL	13
DOCTRINAL ROLES AND FUNCTIONS OF THE G2 AND MI BATTALION COMMANDER	15
G2 EXPERIENCES	20
IV. ALTERNATIVES.....	22
DIVISION INTELLIGENCE COMMAND (DIVINT).....	22
DISBANDING OF THE MI BATTALION	24
RETAIN CURRENT STRUCTURE	26
REDEFINED ROLES	27
V. ANALYSIS AND DISCUSSION.....	32
DIVINT	32
DISBAND MI BATTALION	34
CURRENT STRUCTURE.....	36
REDEFINED ROLES	38
ANALYSIS RESULTS	41
VI. CONCLUSION	42
G2 ROLES AND FUNCTIONS	43
MI BATTALION COMMANDER ROLES AND FUNCTIONS	44
APPENDIX A (INTERVIEW QUESTIONS).....	47
APPENDIX B (ASSISTANT CHIEF OF STAFF, G2 (S2), INTELLIGENCE	48
ENDNOTES	51
BIBLIOGRAPHY.....	56

List of Figures

FIGURE 1. DIVINT DIAGRAM	22
FIGURE 2. DIVINT DIAGRAM (MODIFIED).....	23
FIGURE 3. DISBAND MI BATTALION	25
FIGURE 4. CURRENT STRUCTURE	27
FIGURE 5. REDEFINED ROLES AND STRUCTURE	28

I. Introduction

Introduction

The intelligence system of systems has changed remarkably over the past fifteen years since the formation of the first Military Intelligence (MI) battalions in the early 1980s. The formation of the MI battalion in a U.S. Army heavy division brought a Military Intelligence commander of the same rank as the G2 into existence. This ordinarily would not have been a problem since one is primary staff and the other a commander. U.S. Army doctrine is very clear as to the responsibilities of line and staff officers. The potential confusion arises because no other primary staff officer has such interdependence between the battalion and the staff officer. The G1, G3, and G4 do not have a battalion commander that is such a fundamental part of their business. The DISCOM commander does not provide the people and resources to the G4 to accomplish the G4's mission. There is not a reallocation of assets to the staff. This not to say they do not have a close relationship which is essential for mission success. The relationship between the G2 and the Military Intelligence battalion commander is further confused by calling the G2 "the senior intelligence officer".¹ These disconnects lead to questions for the Military Intelligence Corps.

Have the roles and functions of the heavy division G2 and Military Intelligence battalion commander changed so that the division no longer requires both in their current form? This is the research question this paper will answer. Understandably, there is some hesitancy to bring up the need for two Military Intelligence lieutenant colonels in

this time of downsizing. Some feel that the Military Intelligence Corps needs to hang on to what it has. The more important action is to be able to justify requirements.

This paper briefly describes the background to the question of the roles and functions of the G2 and MI battalion commander and whether the heavy division still requires both in their current form. It explains the terms intelligence architecture and intelligence system since they are critical to understanding the roles and functions of the G2 and MI battalion commander. Chapter Two examines the methodology and evaluation criteria. Chapter 3 reviews current doctrine on the roles and functions of the G2 and MI battalion commander. It highlights discrepancies and the need for change. Chapter Four proposes four alternatives to examine whether both LTCs are still needed or is one LTC MI in a heavy division sufficient. The obvious question is whether or not one lieutenant colonel can effectively manage the intelligence system. In seeking to answer this question, the paper proposes four viable alternatives of which two have a single LTC MI in charge of the intelligence system. The paper examines four options for solving the problem of defining the roles and functions of the G2 and MI battalion commander and whether the U.S. Army still needs both.²

The options are as follows:

- 1.) DIVINT Structure
- 2.) Disband MI battalion and assign intelligence assets to units
- 3.) No change from current structure
- 4.) Redefined MI battalion commander and G2 roles

The first option, DIVINT, eliminates the G2 and replaces him with a MI battalion commander assuming the status of a Division Intelligence coordinator (INTCOORD). This is modeled along the DIVARTY commander and FSCoord positions. The second option disbands the MI battalion and assigns the elements to the maneuver brigades and to the staff much in the same manner as the battalion organizes for combat. Rather than habitual DS and GS roles, the intelligence personnel and systems would be organic to the units. The third option retains the current with the MI battalion commander and G2. The fourth option involves a modification of the current structure with organizational and doctrinal changes while maintaining a MI battalion commander and G2. Their new roles and functions will be defined.

With the exception of the third option, all these alternatives require different roles and functions for the G2 and/or the Military Intelligence battalion commander. The role and function of the G2 and the MI battalion commander need to be defined to take advantage of new technologies and information management practices to provide the best intelligence support to the commander. These roles and functions should not only solve current problems but address the future as well. The role and function of the G2 requires modification to allow greater leveraging of the MI commander. The roles and functions of the MI battalion commander should be defined to eliminate confusing responsibilities and awkward work-arounds that rely on commander's personalities and friendships to succeed rather than doctrine to accomplish the mission.

Each of the options are evaluated in Chapter Five with the evaluation criteria explained in Chapter Three to determine the best alternative for the most effective intelligence system. The grading scale is excellent, good and satisfactory. A matrix is

listed at the end of Chapter Five with the results of the evaluation. Chapter Six selects the best alternative and explains the delineation of roles and functions in the areas where there is confusion in the doctrine.

Background

How did this situation arise? In 1979, the creation of a Military Intelligence battalion led to the transfer of some of the responsibilities and capabilities for collection and analysis of information away from maneuver commanders and the G2 to this new position. Given the highly technical nature of the information collected, namely Signals Intelligence (SIGINT), this was the smart thing to do.

The creation of the MI battalion in the late 70's was necessary to provide intelligence support under the control of the supported commander. As BG James A. Neal, Commander of the Intelligence Center and School wrote in *Military Intelligence* magazine in 1980, Combat Electronic Warfare and Intelligence (CEWI) was a validated concept. It brought the different intelligence disciplines into an integrated single organization under the full command of corps and division commanders.³ The emphasis of his article and the MI units seemed to be on the acquisition of needed intelligence collection systems. There never seemed to be enough equipment to accomplish the mission. In a following article, COL Joseph C. Wilson wrote about his experiences as the commander of the first MI Group. He solved the problem of responsibilities between himself and the G2 in a Memorandum of Understanding (MOU). His MOU recognized the G2 as responsible for the production of intelligence while the MI Group provided the assets.⁴

Unfortunately, the relationship between the G2 and Military Intelligence battalion commander has not changed since COL Wilson's article in 1980. Except now the G2 no longer owns the assets to do analysis as during COL Wilson's tenure. Since the Military Intelligence battalion has changed form, the roles and functions need to be redefined.

Why *does* the intelligence system require two Military Intelligence lieutenant colonels when the other battlefield operating systems do not? Air Defense Artillery, Signal and Engineer do not have a lieutenant colonel on staff and another in command. They are able to function with a Major working under the guidance of the G3 but still responsible for their battlefield operating system. The Major on staff does the planning and the LTC battalion commander is responsible for the functioning of the system. The DIVARTY commander is able to fulfill his role as commander and fire support coordinator for the division. Modifications of this theme are discussed in Douglas A. Macgregor's *Breaking the Phalanx*.⁵ These ideas are reasonable questions that arose during the collection of information for this paper. Surprisingly some of these questions arose from former G2s and MI battalion commanders. It was curious on how the serving G2s and Military Intelligence battalion commanders talked about the importance of teamwork and getting along with one another while the former and some serving officers talked about bad relationships they had been in or observed.⁶

The Intelligence System and Architecture

Before continuing the discussion on the need for two MI LTCs in a division, it is important to define two terms that are often incorrectly used within the intelligence community: intelligence system and intelligence architecture. Intelligence has been

described as a system of systems. “The intelligence BOS is built upon the premise that the whole is greater than the sum of its parts.”⁷ There is not a definition in FM 34-1, *Intelligence and Electronic Warfare*, of the intelligence system. The terms, intelligence Battlefield Operating System (BOS), intelligence system, and intelligence architecture are used interchangeably in some portions of the manual. At other times, there appears to be an implied difference in the terms.⁸ The term “Intelligence architecture” is even harder to define from FM 34-1. The first time the term appears is in a definition of the intelligence battlefield operating system.

“Intelligence supports the Army as a whole through the intelligence BOS. The intelligence BOS is a flexible and tailorable *architecture* (italics added) of procedures, personnel, organizations, and equipment that responds to the intelligence needs of commanders at all echelons. The Intelligence BOS architecture provides specific intelligence and communications structures at each echelon from the national level through the tactical level. These structures include intelligence organizations, systems, and procedures for collecting, processing, analyzing, and delivering intelligence to decision-makers who need it. Effective communications connectivity and automation are essential components of this architecture.”⁹

Architecture appears to be part of the intelligence BOS when it is next discussed under force projection operations.

“During force projection operations, MI uses intelligence BOS procedures and architecture, established during peacetime, to ensure that the force commander is supported with accurate and responsive intelligence from predeployment through redeployment.”¹⁰

The definition of intelligence architecture in FM 34-1 is non-existent. In the draft version of FM 34-10, *Division Intelligence and Electronic Warfare*, intelligence architecture is used more frequently and usually in the context of communications.

“The MI battalion SIGO is responsible for the laydown of the divisional intelligence architecture. He works for the XO and supports the ACE Chief and the S3 in establishing assured communications architecture.”¹¹

“The G2 and MI battalion commander configure the intelligence architecture and IEW operations to provide continuous intelligence support during the six stages of a force projection operation.”¹²

The G2 and MI battalion commander must consider many elements in the development of the division’s intelligence architecture.”¹³

Although prominently mentioned several times, there is not a definition of the intelligence architecture.

It is better defined and explained in Chapter VII, *The Joint Intelligence Architecture, Joint Publication 2.0, Joint Doctrine for Intelligence Support to Operations*. The joint intelligence architecture provides a multimedia communications network with interoperable systems that link units and intelligence organizations in a global grid.

“ The joint intelligence architecture provides the means to interconnect collectors, producers, customers in an information network. All intelligence made available to the network from any source is stored and communicated as data whether it is a text file, graphics, imagery or formatted information.”

The joint intelligence architecture is a dynamic, flexible structure providing global access to an information grid that consists of all intelligence sources at all echelons. The joint intelligence architecture is configured to provide access to all intelligence sources from anywhere.¹⁴ This is the definition this paper will use.

The intelligence architecture is part of the intelligence system. It is the structure by which data is moved between collectors, producers and customers. The intelligence architecture consists of the communications equipment and the people who operate it. It

is not simply equipment. The main difference between the intelligence architecture and the signal battalion's communication nets is that the personnel in the intelligence architecture manipulate the data as well as move it. They manipulate it into a form that the consumer desires.

For example, an All Source Analysis System operator may receive the locations of enemy Air Defense Artillery (ADA) Radars. He can process the data to create an electronic overlay to show where the enemy ADA coverage is located around a certain objective. This intelligence could then be combined with intelligence from the terrain detachment to show the best route for a deep attack by helicopters. Once the ASAS operator manipulated the data and pulled it off the ASAS machine, it left the intelligence architecture and became part of the intelligence system.

The intelligence system is more than the architecture and the collectors. The intelligence system includes the intelligence input into the Military Decision-Making Process, the link between the G2, the BDE S2s and the separate battalion S2s, and interaction with outside agencies. The intelligence system contains the link between the collection manager, the G2 and G3 plans officers and the formulation of the Decision Support Template (DST) and its use by division operations. There is not an electronic link in this case. A procedural link exists to ensure the intelligence collectors are answering the commander's Priority Intelligence Requirements (PIR) in a timely manner. The intelligence system is composed of many systems of which the architecture is but one part.

It is important to understand that there is a difference between the intelligence architecture and the intelligence system. The intelligence architecture is an integral part of the intelligence system. This is important when discussing who has responsibility for either the intelligence architecture or the intelligence system.

II. Criteria and Methodology

Criteria

Before proposing the alternatives, the criteria for evaluating them will be explained. The criteria for evaluating any change in roles or functions of the G2 and the MI battalion commander are straightforward and simple. They are better intelligence, practicality, training and unity of command and purpose.

Better intelligence is defined as analyzed information answering the priority intelligence requirements in a timely fashion. Any new role cannot just speed up the flow of information. Information must be analyzed and turned into intelligence before being passed to the commander. The analysis must be performed by someone of the appropriate rank and experience. This is the critical function.

Any new function or structure must be practical. The job descriptions must be within the capabilities of the position. The duties and time demands need to be within the capabilities of a normal officer with appropriate training. The U.S. Army can not design a position that requires a master in information management and computer science if the U.S. Army is not going to assess and retain such officers in the MI Corps. Officer accessions and job assignments must lead to producing the necessary officers for the positions.

A change in functions needs to address who is responsible for what aspect of training. Intelligence is described as a system of systems. Each part of the system needs to be trained to the same level for the system to function. The preponderance of low density Military Occupational Skills (MOS) spread over multiple units and staffs

increases the difficulty of the task. A single point of contact for training and execution is the ideal.

Unity of command and purpose addresses the maneuver commander's need for a structure that better supports him. This is often a decision as to whether it is better to consolidate scarce resources for training and maintenance or it is more advantageous to assign assets to their habitually supported units to become an extension of the commander's will. The commander must be able to tailor his forces to accomplish the mission. Any function must consider how it will affect the commander's ability to forge an effective team.

The criteria grading scale will be excellent, good and satisfactory. Each of the options will be evaluated individually. There may be more than one option, which receives the same grade on a criterion. The selected option will have the highest overall grade in all four criteria. A table will be presented at the end of the analysis and discussion chapter that records all the results.

Methodology

Evidence gathering for researching the roles and functions of the G2 and MI battalion commander turned out to be more difficult than imagined. The role of the G2 has evolved over the past seventy-five years to be well defined. Other than that of a commander, the role and function of the MI battalion commander in the intelligence system is vague. Doctrine in field manuals is remarkably brief. It often consists of no more than a line at times. Sometimes he rates a whole paragraph. Draft MI Manuals give him a couple of pages. The shortage of information carried over into military

publications such as *Military Review*, *Military Intelligence*, and *Army* magazines. This was especially strange in the *Military Intelligence* journal. There were only a couple of columns or ½ page articles that dealt with the roles and functions of G2s and MI battalion commander. There has been nothing substantive published on this issue in the past five years since the Analytical Control Element (ACE) was moved back into the MI battalion.

This shortage of meaningful information required a series of interviews with Military Intelligence officers who had been G2s and MI battalion commanders in heavy battalions over the past five years. Given that there are only five heavy divisions in the force and battalion command tours last two years, there were less than twenty-five possible personnel available to interview. The interview questions listed in appendix A were chosen as a starting point. The five-year deadline was chosen to correspond with the creation of Analytical Control Element (ACE) and its assignment to the MI battalion.

Current published Military Intelligence manuals as well as those draft manuals available over the Internet on the Fort Huachuca Intelligence Center and School home page were used. Some of these manuals are draft and subject to revision but they serve as a valuable road map to see if the problems are being addressed. As such they are quoted and used.¹⁵ They are an indication of future thought. The other source for the future is the series of pamphlets published by TRADOC on Force XXI.

III. Personnel, Roles and Functions

Personnel and their roles and functions will be discussed next. It is important to understand the major elements and personnel in the intelligence system and their location on the battlefield.

ACE, G2 and MI Personnel

Since a constrained resources environment is assumed, a review of G2 personnel and their locations in the command posts as well as selected MI battalion personnel is appropriate. There will be a minimum of additional personnel added or deleted in all four options.

One of the most recent organizational changes was the formation and addition of the ACE to the MI battalion. The ACE was formed from the All Source Intelligence Center (ASIC) located in the Division HHC under the control of the G2 and the Technical Control and Analysis Element (TCAE) located in the MI battalion. It was put in the MI battalion due to a Department of the Army directive for the sole reason of reducing the size of the division Headquarters Company.¹⁶ The ACE is the center of operations for the division's IEW effort. The ACE consists of single source analysis sections (SIGINT, IMINT, etc), an all source analysis section, a collection management team and a targeting cell. The ACE is OPCON or DS to the G2 from the MI battalion.¹⁷ The ACE provides the G2 with his primary means of producing intelligence.

The reorganization and reassignment of G2 analytical personnel to the newly formed Analytical Control Element (ACE) left the G2 with eleven personnel assigned to the division staff of the division HHC. Of those eleven, nine are intelligence personnel. These personnel are responsible for G2 operations and special security operations (SSO). The G2 Plans officer is in the Plans section. The proposed tables of organization (TOE) for the digitized divisions (TOE87004F100) remain essentially unchanged from the current heavy division TOE (TOE87004A100) in the G2 main/current operations.

The big differences are in the G2 TAC and G2 rear command post sections. The G2 rear CP section is eliminated and the G2 TAC personnel are increased. Since it would be unwise to design a Command Post to serve the needs of the intelligence system, the missions of the TAC CP and Main CP will remain unchanged. The function of the G2/TAC CP in Force XXI (TOE87004F100) is to maintain communications with the S2s of the maneuver brigades, separate battalions and separate or special purpose intelligence gathering assets. Digitization will allow the TAC to constantly exchange information with the G2 Main CP to maintain the current enemy situation. It also contains an intelligence support team from the ACE. The deputy/assistant G2 is in the TAC. He is supported by one other captain and four enlisted analysts.

While the G2 TAC maintains the current battle, the G2 main concentrates on production of intelligence products through the IPB process. The production of intelligence products is accomplished by the ACE. The G2 identifies high value targets and recommends priority intelligence requirements. The G2 also directs counterintelligence (CI) operations and support. He directs these operations from the Division Main Command Post and maintains contact with MI battalion commander.

The MI battalion commander is the primary intelligence collector for the division. The MI battalion fulfills tasks generated by the G2 and G3. The MI commander executes the collection of intelligence through the use of the battalion's organic, assigned, or attached IEW assets from Echelons Above Division (EAD). While many of his personnel work directly for the G2, especially the ACE, it is still his responsibility to train, maintain and provide overall support for the individuals.¹⁸ The MI battalion commander has the normal complement of battalion officers and staff to assist him in his duties.¹⁹

As can be shown from the number of personnel in the G2 sections, the G2 does not have many personnel to help him with his many responsibilities. The TOE places his deputy in the TAC while his position is in the main. This lack of depth in personnel constrains his options in accomplishing his tasks.²⁰ The G2 is dependent on the ACE to accomplish his analysis so that he can function as the senior analyst in the division. The G2 is dependent on the MI battalion commander to train the ACE so it can perform its mission to support the G2. It is therefore critical that the roles and functions of the G2 and MI battalion commander be defined so they can accomplish their primary mission of providing timely, relevant and accurate intelligence to the commander.

Doctrinal Roles and Functions of the G2 and MI battalion commander

Now that the resources (personnel and their location) available have been reviewed, current doctrine will be examined. Before proposing new roles and functions for the MI battalion commander and G2, it is necessary to review current published roles and functions. Function will be defined as "the action for which a person or thing is

particularly fitted or employed or an assigned duty or activity”.²¹ A role is a “function or position”.²² Function will be the task and who is responsible for accomplishing it. Role will be who does what in particular situations or the line between staff and command. Examples are wargaming, resource reporting, intelligence estimates and appendixes, and command matters.

It is necessary to examine MI, Division operations and staff Field Manuals to gain a full appreciation of the G2 and the MI battalion commander roles and functions. The division G2 role and function has remained unchanged since the 1984 printing of the FM 101-5. It has remained essentially unchanged for 30 years.²³ The 1997 FM 101-5, *Staff Organization and Operations*, lists the duties and responsibilities of the G2: “The G2 (S2) is the principle staff officer for all matters concerning military intelligence (MI), security operations, counterintelligence (CI) and military intelligence training.”²⁴ A complete listing and definition is found in appendix B.

In FM 34-1, *Intelligence and Electronic Warfare*, “The G2 is the commander’s senior intelligence officer and primary staff officer for intelligence at Army service component-level through battalion.”²⁵ The term “Senior Intelligence Officer” was probably first included because there were two Military Intelligence LTCs in the division and it was felt that there had to be an order of importance in the intelligence system. Date of rank was ineffective and there is no chain of command between the two officers. It was probably an attempt to eliminate confusion. The problem is that this gave license to some G2s to cross the line from staff to command business. This subject arose during a number of interviews with former G2s and MI battalion commanders.²⁶

In FM 71-100, *Division Operations*, the G2 cell is better explained.

“The G2 cell at the main CP requests, collects, analyzes, produces, and distributes weather information, intelligence and time-sensitive combat information about the enemy for the division’s deep, close and rear current and future operations. It comprises a G2 operations element, an ACE, an Air Force weather team and a division terrain team... the G2 and his staff provides critical information on the enemy for divisional operations. They analyze the data presented concerning the enemy force and using US doctrinal concepts, translate it in terms understandable to the commander.”²⁷

Discussing the roles and functions of the MI battalion commander is not as clear cut in doctrine. In the 1994 version of FM 34-1, *Intelligence and Electronic Warfare Operations*, the roles and functions of the MI commander are defined as follows:

“The MI Commander executes IEW operations using his organic and attached assets. He is responsible for providing the commander with a trained and mission-ready IEW force. He develops MI leaders capable of leading small teams in OOTW and companies or battalions in war. In war and OOTW, the MI commander is responsible for C², maneuver, sustainment and protection of his unit. The MI commander ensures his unit executes the G2 (S2) intelligence SOR and G3 (S3) SOR in concert with the concept of operation. The MI commander anticipates the IEW operational requirements of future operations.”²⁸

This definition is no different from any other commander. This definition is clear until you compare it to the G2’s responsibilities in the preceding paragraph in the field manual. It states that “the G2 (S2) supervises the intelligence training of the unit and his staff.” One supervises the training of the unit and another is responsible for a trained and mission ready force. FM 34-1 attempts to reconcile conflicts like the training issue by stating

“The G2 (S2) and MI commander are a team whose mission is to provide IEW support to the commander. As a team, they are responsible to the commander for planning and directing the intelligence activities of the command. Together, they develop standards for IEW training and operations.”²⁹

Rather than relying on doctrine for a delineation of roles and functions, G2s and MI commanders are to work out their own understanding. This process is further explained in FM-34-10 (DRAFT) *Division IEW Operations* under the Battle Command chapter. The role of the MI battalion commander and staff are defined as follows:

“The division has an arrangement between the MI battalion commander and the G2. The G2 is the division’s senior intelligence officer advisor to the commander on intelligence matters. The MI battalion commander is a commander who also reports to the commanding general on intelligence matters, the status of his battalion, and its ability to meet its mission.

The MI battalion commander is responsible for the collection of intelligence through the use of his organic, assigned, or attached IEW assets. Some of the battalion’s personnel, such as those in the ACE, work directly with the G2. However, he is still responsible for training these personnel, maintaining their equipment and system, and providing overall support.”³⁰

“The MI Battalion Commander is just that, a commander. He is the primary intelligence collector for the division. By virtue of his position as the primary collection officer within the division, he reports to the commanding general in intelligence matters.”

FM 34-1 also devotes a number of pages (4-11 through 4-14) on the internal command and control of his unit but nothing on how he fits into the intelligence system. Although not reflected in doctrine yet, the MI battalion commander is no longer just a manager of assets. He controls the quality of analysis of information as well as the collection of information. He controls the analysis through training and ownership of the assets.

As has been shown in the preceding paragraphs, finding a doctrinal or approved definition or delineation duties of the MI commander and the G2 is difficult. Each of the definitions taken alone seems reasonable and correct.

The problem arises when you compare them to the more fully developed and accepted job description of the G2. The job description of the G2 has remained essentially unchanged for thirty years in U.S. Field Manuals. All the Military Intelligence Field Manuals are emphatic that the G2 is the senior intelligence officer (SIO) in the division as well as that the MI commander is a commander. The term SIO does not appear in FM 101-5. One is staff and the other is a commander. Simply stating one is a commander and the other primary staff is not as clean cut in the intelligence business as it might be in maneuver or combat arms. The problem is that they are both trying to manage a system: the intelligence system. Neither doctrine nor tactics, techniques and procedures addresses who is responsible. The intelligence system is described as a "system of systems." A system needs one overall manager or leader. Dividing it between two somewhat equal partners reduces the efficiency of the system. The system is composed of identifiable components.

For example, what does "senior intelligence advisor to the commander" entail? Is the G2 expected to answer questions or provide advice on all intelligence collection systems? Or would it be better to ask the commander who owns and uses the assets?³¹ The G2 should not be expected to answer such questions. Who should design the architecture? The person who uses the information the architecture produces or the one who has to build it, use it and maintain it? It was not until the Gulf War that these questions started to surface. It was easy to muddle through exercise scenarios during Battle Command Training Programs. It took an actual wartime deployment and combat to expose these problems.

G2 Experiences

One of the most detailed and comprehensive looks at the functions and roles of the Division G2 was written by BG Quirk after the Gulf War. He detailed his experiences as the G2 of the 24th ID (M) during its participation in the war. His discussion of interaction with the MI BN commander is limited to three and a half pages out of 318. This is partially attributed to the fact that he owned the personnel that would form the ACE. He also, with MG McCaffrey, redefined the role of the senior intelligence officer in the unit. MG McCaffrey saw himself as the senior intelligence officer while the G2 was the senior analyst. This subtle difference resulted in some changes in the way the G2 section operated. McCaffrey's version of a G2 and Deputy G2 is more in line with the current ACE chief and his battle captains. Given this focus, it is understandable why LTC Quirk had little time to command or overwatch the intelligence system if he was analyzing the information full time and providing analysis to the commander.

LTC Quirk, G2, didn't see many problems in the relationship between himself and the MI battalion commander during the 24th ID(M) deployment during Desert Shield/Desert Storm. He saw the key to success as a strong personal relationship between the two. He saw the significant factor as the fact that the MI BN commander had spent three years as a G2. He believed that the MI commander was fully employed as an executor of orders. The MI commander worked for the ADC (M) and CG in working a specialized piece of the MI mission. LTC Quirk's only connection was in designing the collection plan and using the collected information along with the rest of his intelligence sources. He left the collection mission to the MI battalion commander. He controlled all facets of the analysis.

It was easy to initially dismiss this situation as a command idiosyncrasy of MG McCaffrey. As further research demonstrated, MG McCaffrey had noted the discrepancy. Although MG McCaffrey seemed in BG Quirk's work to concentrate on refocusing the mission and priorities of the G2, the recent organizational changes make his thoughts relevant to the roles and functions of the MI battalion commander as well. BG John Stewart furthered this idea of the Senior Intelligence Officer in his work published after the Gulf War as the Third Army G2 describing it as one of the tenets that MI must maintain.³²

With this insight and the doctrinal confusion and vagueness resident in US Army Field Manuals, the next chapter will look at four options to define the roles and functions of the MI battalion commander and G2. These alternatives will examine whether or not it is possible to reduce the confusion of responsibilities by combining the functions under a single commander or a single staff officer as well as modifying the current structure.

IV. Alternatives

This chapter explains the four options for deciding whether or not the heavy division still requires an MI battalion commander and a G2. As mentioned earlier, one option removes the G2, another removes the MI battalion commander, current structure, and the final one is a modification of the current system. The alternatives will be analyzed in the following chapter.

Division Intelligence Command (DIVINT)

Figure 1. DIVINT Diagram

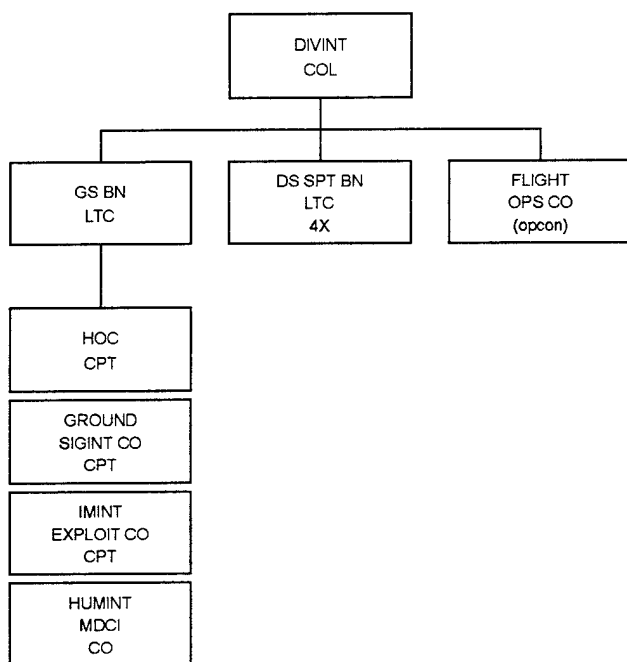

The Division Intelligence Command (DIVINT) is modeled on the division artillery (DIVARTY) structure. MAJ Tom Felts proposed a version of DIVINT in his monograph “Building a Tactical intelligence Model for the information-based Force”. His model was a brigade-sized force with an intelligence Colonel as the commander with no G2. There are three Direct Support (DS) battalions and a General Support (GS)

battalion in addition to an ACE. It is also resourced to provide intelligence support down to the company level along FIST lines. MAJ Felts assigned information warriors down to the company level.³³

His structure is very robust with a lot of capability, but it bucks the trend of smaller units. My version of a DIVINT is achieved through the relocation of Military Intelligence assets and removal of the LTC MI G2.

The DIVINT would be a LTC that would combine the roles and functions of the MI battalion commander and the G2. The DIVINT is responsible for the intelligence and architecture. The DS company team and ACE would remain essentially unchanged with minor modifications. The unmanned aerial vehicles (UAVs) would be assigned to the aviation brigade in the same manner as the Quickfix helicopters.

Figure 2. DIVINT Diagram (Modified)

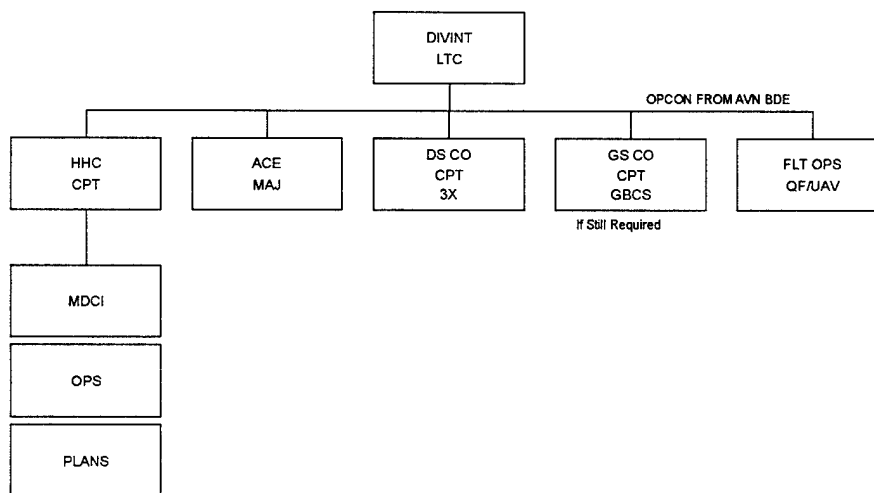

Ground based SIGINT in the form of Ground-Based Common Sensor (GBCS) is eliminated from the MI battalion. This assumption is made based on comments from

senior Military Intelligence officers, BG Wayne Hall and MG John Thomas, and the Rand Study which question the need for tactical ground based SIGINT.³⁴

The HHC, ACE and the DIVINT will be located in the Division Command Posts (TAC and Main). The ACE will be located at the Main Command Post. The operations section will split between the Main and Tactical Command Post. The Plans section will be at the Main CP. The majors located in the Plans, operations and TAC will assume added importance. They will be the intelligence representatives to the command staff for the majority of the time. The DIVINT will be available for crucial decisions but will concentrate on ensuring the battalion accomplishes its mission.

Quickfix and the UAVs would be OPCON to the MI battalion as under current doctrine. Projected technology is expected to solve the downlink problem with the UAVs. Moving the UAVs to the Aviation Brigade simplifies maintenance, launch, and recovery while reducing the signature and displacement and emplacement times of the Brigade TOCs.

Disbanding of the MI Battalion

One way to eliminate the confusion between the G2 and the MI battalion commander is to eliminate the MI battalion. The assets would be assigned to the brigades and G2 in much the same way they are deployed for combat. This option has much in its favor in keeping true to the precept that the U.S. Army trains as it fights. The G2 is a time-tested role and function that is integrated into the Military Decision-Making Process (MDMP).

The Analytical Control Element (ACE) is resubordinated back to the G2 and assigned to the Division Headquarters Company. The Direct Support (DS) companies are divided between the Brigade Headquarters Companies and the Brigade S2 sections. The Unmanned Aerial Vehicle (UAV) sections are merged with the Quickfix platoon in the aviation brigade. The Counter-intelligence personnel are back in the G2 section.

Either the tactical SIGINT mission is eliminated or the (GBCS) Ground-Based Common Sensor System is assigned to DIVARTY and OPCON to the G2. The GBCS can be managed in much the same way as the Target Acquisition Battery with its counter-battery radars. This is not as odd as it seems. One of SIGINT's biggest tactical missions is locating enemy artillery. This assignment ensures a closer sensor to shooter link. It follows the pattern of the Quickfix to the aviation brigade where it can be better supported logistically.

Figure 3. Disband MI Battalion

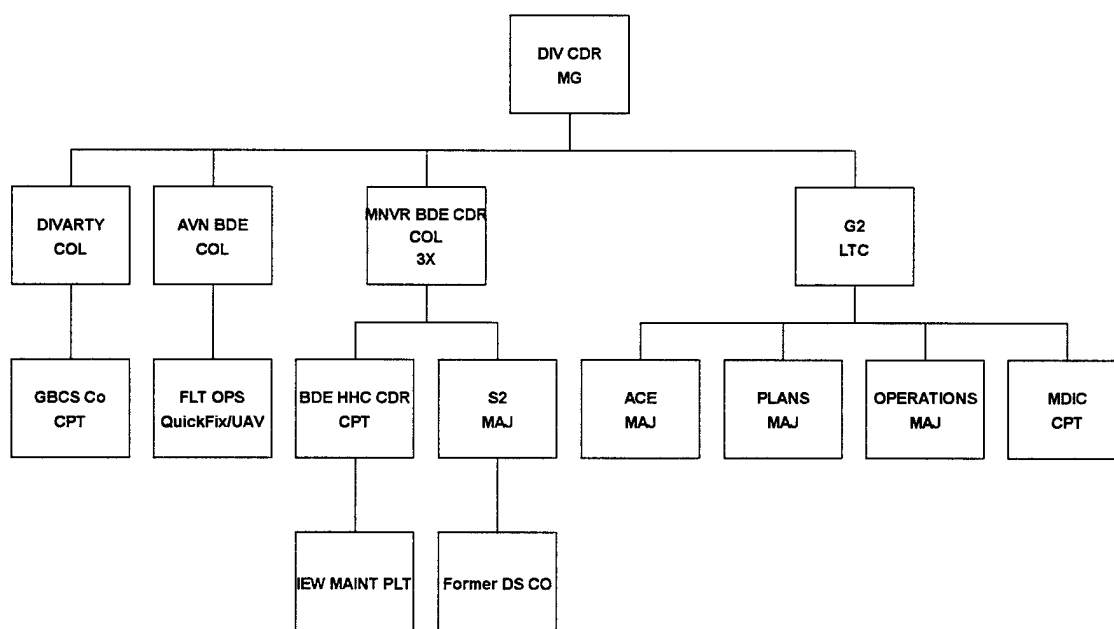

The Brigade S2 would integrate the capabilities and personnel of the Analytical Control Team (ACT) into the section. Maintenance personnel are assigned to the brigade headquarters maintenance section. There would be no reduction in personnel and the section would train as they fight. The only positions lost would be company commander and 1SG. The personnel would remain but the job titles would change.

The Brigade S2s would achieve greater importance since the MI battalion S3 and MI battalion Executive Officers would disappear. The maneuver brigade S2s would become the branch qualifying positions for MI field grade officers.

The G2 in this option, remains a staff officer while the Headquarters Company commanders at Division and Brigade assume the command functions. The G2 (in partnership with the G3) is responsible for the training and functioning of the intelligence system within the brigade. The operations officers at all levels write the reconnaissance and security plan in association with the intelligence officers. Electronic intelligence collectors are treated no differently than scouts, aviation, or counter-battery radars.

Retain current structure.

The third option leaves the current structure intact with an MI battalion commander and a G2. The G2 is a primary staff officer who works under the supervision of the Division Chief of Staff. His intelligence duties and areas of responsibility are found in Appendix B. The MI battalion commander is a commander of a separate battalion who is rated by the ADC(S) or ADC(M). The G2 and MI battalion commander's doctrinal roles and duties as described in FM 34-10 were discussed earlier in Chapter 3.

Figure 4. Current Structure

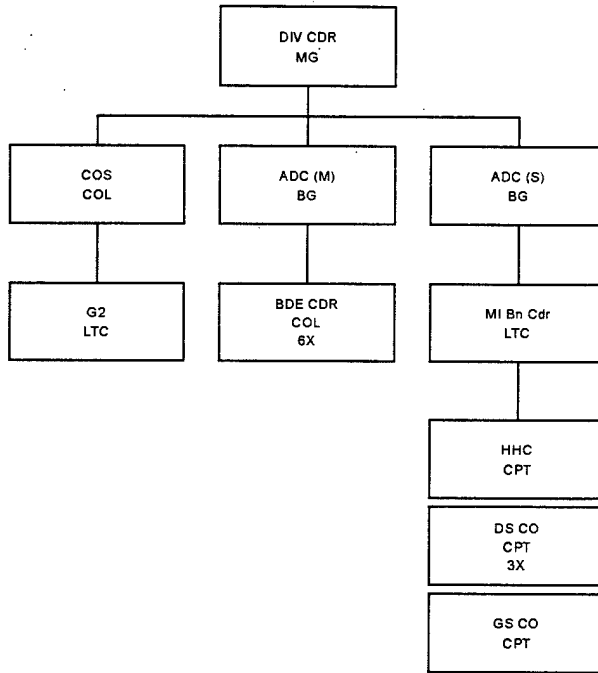

Redefined Roles

The redefined roles alternative retains the MI battalion commander and G2 but in different roles. The MI battalion also modifies its structure slightly. The term Senior Intelligence Officer is removed from the definition of the G2. It is an archaic term that is out of step with the rest of the branches. There is no senior maneuver officer, senior personnel officer or senior logistics officer. The G2 becomes the senior analyst for the division who tasks the intelligence system. His main job is to make the prediction for the commanding general. He works with and is responsible for training the brigade S2s.

The G2 now concentrates on making predictions for the division commander.³⁵ Force XXI intelligence is designed to be predictive in nature. The debate over whether to

merely enumerate capabilities or make predictions is considered settled. The prediction is the decision as to what the enemy is going to do. This could be during the Military Decision-Making Process with Mission Analysis and Wargaming or during the actual operation for support to the decision support template. The G2 makes the decision on whether enough information has been collected to satisfy the commander's priority intelligence requirements. The division commander obviously has the final decision, but he has the wisdom and experience of an MI LTC to help him. The MI LTC can determine whether the systems available can get any more information or improve resolution. This insight is invaluable to the commander.

The G2 integrates the G2 plans and G2 operations sections. He manages the turnover from G2 plans to G2 operations and ensures that the collection manager was a participant in the development of the PIR and the "latest time information is of value" (LTIOV).

Figure 5. Redefined Roles and Structure

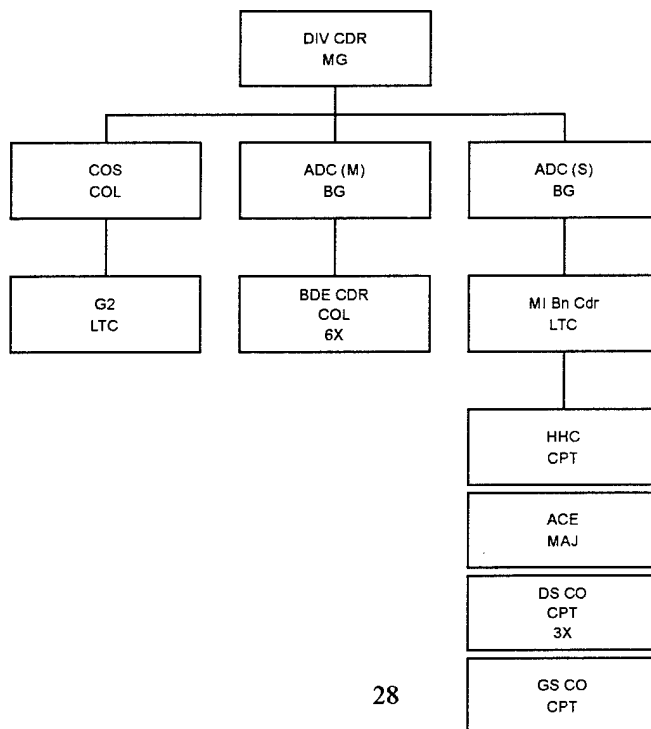

He maintains contact with the brigade S2s in the same manner that the division G3 talks to brigade S3s. The ACE does not serve as his intermediary. His mobility is limited due to his functions within the division main command post (DMAIN). He is required to understand the current status of the ongoing battle and predict the future battle. The best place to accomplish this is the task is the DMAIN due to the connectivity with higher, lower and adjacent units. He tasks the intelligence system to gather information through the collection plan or reconnaissance and security annexes.

He does not manage assets. The MI battalion commander manages the assets. The G2 is not held responsible for the status of Intelligence and Electronic Warfare (IEW) systems and does not command or control any systems that come in support of the division. If an intelligence asset is supporting the division, it falls under the command and control of the MI battalion commander. All IEW assets are attached, OPCON, DS or GS to the MI battalion.

The MI battalion commander is responsible for establishing and maintaining the intelligence architecture. If it comes from outside the division, the MI battalion commander's function is to integrate it into the intelligence architecture. The G2 has no executing responsibility. He is courtesy-copied on the status. The MI battalion commander works under the Assistant Division Commander (Support) ((ADC (S)) to supply a service and product to the division staff. He is similar in some respects to the SIGNAL battalion commander.

The MI battalion commander is responsible for ensuring the dissemination, collection and analysis of intelligence is performed at division level. He ensures the

system functions to provide the right intelligence as tasked by the G2 so the G2 can make his predictions or capabilities assessments. The MI battalion commander does not have an independent voice on what the enemy might do. He is a commander and not an analyst.

One of the services and products he provides is a trained ACE. The ACE has a METL developed by the MI battalion commander. The MI battalion commander ensures they are trained to standard and can deliver the goods and services required by the G2 and his plans and operations sections. The MI battalion commander trains the Analytical Control Teams (ACT) who are part of the DS company teams in their support of the Brigade S2s. Given the complexity of the All Source Analysis System (ASAS), the MI battalion commander ensures all personnel not assigned to the Brigades can operate the system and use it to its potential.³⁶

The MI battalion Analytical Control Element (ACE) is reorganized as a company to facilitate training and command and control. Given its deployment on the battlefield, size and single unique mission, it requires a company commander. It should not remain as part of the MI battalion Headquarters Company.

There is only one major organizational change between this alternative and the current structure. The analytical control element (ACE) is organized as a separate company within the Military Intelligence battalion.³⁷ The division also retains two Military intelligence LTCs. The role and function of each is modified to more clearly define responsibilities. One role is completely eliminated. The title of Senior Intelligence Officer is removed from the lexicon. The G2 is now the senior analyst for

the division and the MI battalion commander is the commander of all intelligence assets and personnel not assigned to the G2 or S2 sections within their respective headquarters.

The MI battalion commander is responsible for the intelligence architecture.

V. Analysis and Discussion

The four options will be analyzed using the criteria detailed in Chapter 2. The analysis will first determine whether the roles of the G2 and MI battalion commander can be combined into one role thereby eliminating confusion over who is responsible for what portion of the intelligence system. If they can be combined, should the combined role be a commander or a staff officer. If they can not be combined, is the current structure the best that can be achieved or can it be modified to provide clearer guidance on the roles and functions of the G2 and MI battalion commander? The evaluation criteria are better intelligence, practicality, training and unity of command and purpose. The grading scale is excellent, good and satisfactory. The first option reviewed will be the DIVINT alternative.

DIVINT

The DIVINT option receives a “satisfactory” on providing better intelligence to the commander. The single MI LTC is a commander in this alternative is focused on command issues rather than analytical issues. He is better able to collect the information but less positioned to perform analysis. His expertise in analysis and experience is not readily available to the plans cell and command group. He will be out seeing to the welfare of his troops and the functioning of the intelligence system. Analysis would be performed by majors and warrant officers. Although they will perform the majority of the analysis in all four options, in this option the MI LTC is the least available.

Practicality rates a “good.” The DIVINT commander is responsible for both command and as a staff officer to provide input into the Military Decision-Making

Process. He is the only LTC MI in the division. One of the functions will suffer. It is not beyond his abilities. It is simply difficult to accomplish both. He does not have the depth in staff as does the DIVARTY commander.³⁸

The DIVINT alternative is ideal for simplifying training. The DIVINT commander owns the analytical portion in the ACE, the collectors in three Direct Support Companies and the General Support Company, and the G2 Plans and G2 Operations. He can develop an integrated multi-echeloned training plan. Standards in files, databases, communications and reports can be dictated. There is no confusing OPCON or DS relationships between the MI battalion commander and the G2. All of the intelligence personnel not assigned to maneuver unit S2 sections are in one unit, therefore simplifying training. It is for these aforementioned reasons that the DIVINT option rates an "excellent" in training.

Unity of command also rates an "excellent." The DIVINT designed battalion can easily task organize to support the commander's needs. It is easier to task organize platoons in a battalion than to form units from unit S2 sections. The army is familiar with task organizing units for specific missions. The modularity of the DIVINT battalion permits this to happen.

This structure works well with a concept that has brigades fighting dispersed on the battlefield. There is rightly some concern about a battalion commander being able to visit his troops on the battlefield; however, this is mitigated by the fact that DS Company soldiers assigned to the brigades will have their company commanders with them and due to the nature of their location and work will have close interaction with the Brigade

commander and senior leadership. These troops survival and mission accomplishment is tied to the success of the brigade during combat and not to the MI battalion. They will receive the appropriate care and supervision.

Disband MI Battalion

As the first alternative replaced the traditional G2 with a modified MI battalion commander in the role of a DIVINT, the second alternative disbands the MI battalion and eliminates the LTC MI commander. In this alternative, the LTC Military Intelligence Officer is the division's senior analysts. It is also a return to the pre-1980 situation when MI units were not assigned to the heavy division.³⁹

This alternative can provide excellent intelligence. As stated in the definition of better intelligence, it is analyzed information answering the priority intelligence requirement in a timely fashion. The G2 owns all the analytical elements, planning and operational staff at division level. His primary purpose is to serve as the senior analyst in the division. He has all the personnel and resources to accomplish this mission. The addition of two majors formerly serving as the XO and S3 gives him the depth for consistent 24 hours operations in all intelligence functional areas. This option assumes that the Officer Professional Management and Distribution (OPMD) plan would not change and the MI Majors would be available in the same numbers and military education level (MEL 4).

The senior analyst position as the G2 is practical. A normally educated and militarily trained MI LTC is fully capable of performing this duty. There is no conflict between command and staff responsibilities. The career progression would not be

interrupted by having to get command or branch qualifying positions such as Executive Officer or S3. While these jobs are valuable for professional development, they do not contribute very much to being a good analyst. As mentioned earlier, the brigade S2 position would become the MEL 4 branch qualifying position. This would result in MI LTCs having experience in analysis under combat conditions and in making predictions for commanders. He will only have to be one place. He is not split between command and staff functions. These factors lead to an "excellent" rating in practical.

Although the training that results from having a single senior analyst is excellent, the overall training of the intelligence system is only a "satisfactory." The intelligence system needs to be trained as a system to be truly effective. Standards need to be applied and enforced across the division. This is much harder to do without a single person to set and enforce the standards. The G2 would rely on the G3 to task brigade commanders to maintain approved standards. This is obviously the way most of the army works. It is just difficult to train low density MOSs who are responding to other commanders demands. The commanders and S2s may have the best intentions but the division's brigades operate on different training schedules and priorities. Coordinating the resources and time is very difficult. It is feasible to accomplish the training, but hardly efficient or optimal.

The lack of an MI only structure denies the division commander the ability to task organize assets without moving assigned assets from one brigade headquarters company to another. This is especially true for scarce items such as the Ground Station Modules (GSM) which would not be organic to all brigades unless more are fielded. It is better for the brigade commander in that his intelligence assets are assigned to him. He can

develop his warfighting staff and adapt it to his personal style. This especially helps in the Force XXI intelligence task of Present. The products the S2 sections produce will be tailored to the commander based on experience and training. It is excellent for the brigade commander but only satisfactory for the division commander. As it takes away an inordinate amount of the division commander's flexibility, it rates on a "satisfactory" for unity of command and purpose.

Current Structure

The current structure and roles of the G2 and MI battalion commander is the hardest of the four options to evaluate. This is because the roles are so generic and loosely defined given the complexity of the mission. This vague definition of roles does provide the freedom to adapt to changing personalities and talents of the G2, MI battalion commander and division commander. Without a firm foundation to begin with, this understanding of roles as mentioned could take too long and actually degrade the intelligence system. This is especially true given the one to two year duration of the G2 coupled with two years of command in the MI battalion commander and division commander. The infrequency of stressful division staff training events such as a Battle Command Training Program Warfighter may allow almost a year to pass before an understanding is reached.

The current structure results in a "good" for better intelligence. If it was any better, the question of whether the U.S. Army needed two LTC MI in a heavy division would never have arisen. The current situation can be modified to provide good intelligence but it is so dependent on individual personalities and skills. If either

individual is removed from the position their executive officer, a deputy, should be able to step in and the system continue to function. Currently, the G2 is not labeled as the senior analyst. He is the senior intelligence officer which conjures up ideas of managing the assets of the intelligence system, tasking the assets of the intelligence system and maybe evaluating training performed by the MI battalion commander.

The functions are practical. Any MI LTC can become a G2 or a battalion commander. The assignments and training are available. MI battalion commanders are selected by a command board. They are generally selected before they have the opportunity to be a G2. There are instances of LTC coming directly from strategic career directly into G2 positions after not having served in tactical assignments for almost ten years. G2s are currently assigned to positions after consultation with the division commander. This arrangement has been in place for almost twenty years and has sufficient flexibility in the staff and command relationship to tailor it to the Division commander. It doctrinally allows the G2 and MI battalion commander to come to an understanding as to what roles and functions they are going to perform. It has the added benefit of often retaining an MI LTC in a division for 3-4 years since he often switches from the MI battalion commander to the G2 or vice versa. There is a continuity and experience which is beneficial to the command group and intelligence system. Since there are very few qualifications for G2, this option rates a "good" in practical.⁴⁰

Training is "satisfactory" in this alternative. It is what causes the most concern and spills over into the other evaluation criteria. It is often a matter of who is responsible for what portion of the system. As written earlier, if you take the job descriptions separately, they make sense. The difficulty arises when you combine them and try to put

them into practice. The training of the ACE personnel and their relationship to the G2, MI battalion commander and HHC commander is a prime example. The training of the ACTs in the DS Company teams and the Bde S2s and their combined relationship with the G2 is divided. How does one individual who is responsible for the intelligence system as the senior intelligence officer affect training when he doesn't own the assets and influence a commander that is not in the same rating chain?

It becomes difficult to coordinate the training of low density MOS when there is ambiguity in the training responsibilities. Currently the G2, S2s and MI battalion commander are responsible for training their own soldiers. Group training is often attempted but seldom accomplished. The critical idea to remember is that all portions of the intelligence system are dependent on the other portions to be successful. An untrained portion of the intelligence system will undermine the effectiveness of the whole system.

The ability to task organize and modify itself is resident in the current structures. It can address the commander's need for a structure that best supports him. With broadly defined roles, and two LTC MI, its rating in Unity of Command and Purpose is "excellent" in the current alternative.

Redefined Roles

The definition of the G2 as the senior analyst will result in better intelligence. His primary function is to turn information into intelligence to support the commander. He is the most experienced MI officer in the division and he will be making the predictions for the division commander.⁴¹ Under the current system, the G2's intellectual energy is

divided between several different areas. The task of making predictions often fell to the ACE Chief or senior warrant. The G2 is now engaged full time in analytical and synthesis work in this alternative. For this reason, better intelligence rates an "excellent." The MI battalion commander is fully committed to collecting information on the battlefield and obtaining intelligence from outside the division through the intelligence architecture.

The job descriptions are within the capabilities of the individual and can be rated "good" as well. It is entirely possible to train an MI LTC to perform both of these functions and roles. Ideally the battalion commander would transition to be the G2 but this is not required. A series of jobs involving maneuver brigade S2, G2 Plans, operations officer or ACE chief in any combination at the tactical level would prepare a LTC to be a division G2. An assignment at an EAC organization such as NGIC or DIA and the Joint Intelligence Centers for the CINCs would be invaluable to understand what national level intelligence can provide.

The only other additional personnel for the MI battalion commander would be the addition of a space operations officer to the S3 staff and the addition of a Signal Corps Major to the staff. The intelligence architecture is only going to get more complicated, complex and reliant on space systems.

The training area is still not perfect and only deserves a "good." The low density MOSs are still split between the G2, MI battalion and brigade S2 sections. The training piece of the ACE is improved through its own chain of command and removal of the non-

value added HHC commander. With the training of the intelligence architecture solely concentrated in the MI battalion commander, there is one person responsible.

The G2 is no longer responsible to the division commander for the training of the intelligence architecture. Is the G3 or Assistant Division Signal Officer (ADSO) held responsible for the training of the maneuver units or the signal system? No. It is the brigade commanders or the signal battalion commander who responds to the division commander. The G2 does not have management or oversight requirements. As mentioned earlier, the senior intelligence officer title and all the implied, confusing meaning is eliminated. The G2 is responsible for the training of the intelligence system and the MI battalion commander is responsible for the intelligence architecture.⁴²

The Unity of Command and Purpose deserves an "excellent." It retains the flexibility in the MI battalion to task organize for missions and retains the G2 in the DMAIN to forge an effective G2 operations and G2 planning team. There is an individual to handle each of the critical tasks: analysis and command. The MI battalion retains its DS company teams and ability to tailor capabilities to the mission.

The organization of the Analytical Control Element (ACE) and its command and control relationship is a recurring theme amongst the G2 and MI battalion commanders surveyed. The majority felt it should be a separate company in the MI battalion rather than a section assigned to the Headquarters Company. This would alleviate some of the training and command problems with the interaction between the G2 and MI battalion commander. The G2 could address training issues with an ACE commander on the spot rather than working through an HHC commander or the MI battalion commander. The

individuals that the soldiers work for would be their commander rather than a section leader or a staff officer. It would also eliminate the MI battalion HHC commander from a confusing responsibility for training. The major problem with making the ACE a company is that it requires a commander of field grade experience, a major, to be successful. A company grade officer simply does not have the education, training, or experience to be successful. It would also require the additional overhead associated with a company such as a supply sergeant.

Analysis Results

The final results in a table form are located below

Option Criteria	Better Intelligence	Practical	Training	Unity of Command and Purpose
DIVINT	Satisfactory	Good	Excellent	Excellent
Disband MI Battalion	Excellent	Excellent	Satisfactory	Satisfactory
Current Structure	Good	Good	Satisfactory	Excellent
Redefined Roles	Excellent	Good	Good	Excellent

VI. Conclusion

The preceding analysis clearly demonstrates that the U. S. Army Heavy Division requires two Military Intelligence lieutenant colonels for the intelligence system to function. One who is in charge of the system and another who is responsible for the architecture. One officer can not effectively manage both. Intelligence is such a critical part of the Military Decision-Making Process that it requires a full time officer with the experience and training of an LTC. The other battlefield operating systems and branches such as ADA, Engineer and Signal are integrated into the G3 operations section for MDMP and are represented by a maneuver LTC in the G3. DIVARTY has a greater number of staff officers to assist him in his role.

The numbers, complexity and distribution of military intelligence systems and equipment do not work in isolation. A piece of equipment may be located in a brigade area of operations to support it, but is ineffective unless linked to other pieces of equipment spread throughout the depth of the battlefield. MI equipment is inefficient to use in isolation. The LTC MI battalion commander ensures these and additional pieces of equipment are formed into a working intelligence architecture.

Since the need for two MI LTC in a heavy division has been demonstrated, this eliminates the two single LTC options. Each of these options solved one problem in the area of better intelligence or training. Unfortunately, the gaps they created in other areas reduced the overall efficiency of the intelligence system. This leaves the final two options in the current structure or a redefined functions.

The status quo is a workable structure with almost twenty years of experience but it has not kept up with changes in organization and technology. The G2 is held responsible for the intelligence system and its supporting architecture. The MI battalion commander's role is not clearly defined. This leads to arrangements and understandings between the G2 and MI battalion commander. The best alternative is to keep the two LTC MI officers in the roles of G2 and MI battalion commander but redefine their functions. The following roles define areas where the two have overlapped and are not all-inclusive. The G2 still has staff functions to perform and the MI battalion commander still has command responsibilities.

G2 Roles and Functions

The G2's primary function is as the senior analyst to the division commander. He tasks the intelligence system to provide information and intelligence to answer the PIR. He sets priorities, provides direction and implementation guidance. The ACE, G2 plans and G2 operations support him in this endeavor.

His primary training task is to train the Brigade S2s to make predictions. He works as closely with them as does the ACE. They have direct access to him and are not relegated to working through the deputy G2 at the TAC or the ACE Chief. This is a critical relationship. He ensures their commander's PIR enter the system as well as the commanding general's.

The G2 recommends the training priorities through the G3 who forwards them to the MI battalion commander in the form of the Division Training Guidance. The MI battalion commander, as a commander is held responsible for execution. The G2 does

not have staff management over the MI battalion and its training. G2 training is concerned with the subordinate units, internal procedures, interaction with outside agencies and higher units and their role in the division intelligence system. The training of the intelligence architecture is the responsibility of the MI battalion commander.

MI Battalion Commander Roles and Functions

The MI battalion commander acquires some new responsibilities. He has always had command responsibilities over his battalion. He is an executor of tasks and develops, trains, and maintains the intelligence architecture to support the tasks. He takes the missions developed by the G2, tasked by the G3 and develops the system to accomplish them. These are normally in the form of PIR and IR. He integrates any system or capability coming into the division and its intelligence architecture.

There was some concern amongst former G2s and Military Intelligence battalion commanders as to who designed the intelligence architecture. It was felt that since the MI battalion is organized along DS Company Teams that if the aviation brigade or DIVARTY needed a capability, that the Military Intelligence battalion commander would not provide it unless the G2 was serving as the DIVARTY or Aviation Brigade proponent on the staff. Although the task organization is created by the G3 with input from the G2 and MI battalion commander, the assumption needs to be made that MI battalion commander will design an architecture to support answering the PIR and accomplish the mission. If the aviation brigade needs a GSM, it will get one.

Having the G2 design the architecture and the MI battalion commander execute it leads the G2 to getting too involved in the MI battalion's business. The G2 starts

requiring all the maintenance reports, training status, and location on the battlefield to put it together. This leads to G2 people being diverted from plans and operations to maintaining the data and building the architecture. The G2 directs who should be able to talk to whom and what the reporting links will be. The MI battalion commander has the staff to accomplish this task. As for task organization, the G2 sets priorities and the MI battalion commander develops the appropriate task organizations and support relationships.

The MI battalion commander is responsible for training his portion of the intelligence system. As mentioned earlier, the G2 concentrates on training the Brigade S2, G2 Plans and G2 Operations. The MI battalion handles the rest. He trains the ACE and ACTs to work ASAS and provide the products the G2 (S2) requires. He trains all the collectors from CI, SIGINT and IMINT. He ensures the communications architecture can support the intelligence architecture. It is here that he may need a Signal Corps Major instead of a captain and a Space operations officer in the S3. This will reinforce his capabilities.

This change does not affect only Military Intelligence officers. Commanders need to be informed as well. Almost all division commanders have been G3s and most probably have experience being an S1 or S4 at battalion or brigade level. Few, if any, have any experience being an S2 or G2. They need to know who is responsible for what piece of the intelligence system in the same way that if trucks are not getting fixed, they go to the DISCOM commander and not the G4.

The question of whether the heavy division still requires a G2 and an MI battalion commander is answered affirmatively. There are staff and command functions within the intelligence system that must be performed. A single individual is not capable of performing both roles. Upon closer examination, similarities to the DIVARTY or Signal battalion situations do not apply to the intelligence system. The DIVARTY commander has a larger staff and more experienced commanders. The Signal battalion staff representative operates under the guidance of the G3 and the signal battalion does not manipulate the data it moves through it's system.

Two Military Intelligence lieutenant colonels are required. One, a staff officer, is required to manage the intelligence system. Another, a commander, is required to train, build and maintain the intelligence architecture so the intelligence system can function. U.S. Army doctrine does not adequately address this separation in doctrine. It does not adequately address the difference between the intelligence architecture and system in current or proposed doctrine. A modification of the roles and functions of the G2 and the MI battalion commander accompanied by the creation of a separate ACE company within the MI battalion will improve the intelligence system. If you redefine the roles and functions to clearly articulate the MI battalion commander's and G2's role in the intelligence system, you end up with a better intelligence system. Effort is not wasted fighting over doctrinal responsibilities and personalities are not the dominant factor.

Appendix A (Interview Questions)

1. What did (do) you see as the role of the MI BN Commander? What your biggest disappointment in the job?
2. What did (do) you see as the role of the Division G2? What your biggest disappointment in the job?
3. What doctrinal or structural changes would you make, if any, to the relationship between the G2 and the MI battalion commander?
4. In what areas, did their responsibilities overlap?
5. Do you have a suggested structural, doctrinal or TTP change that would alleviate the overlap?
6. What were the two biggest challenges to integrating the Military Intelligence battalion into the G2 staff and the Military Decision Making Process?
7. Who was responsible for the training of the Intelligence system within the division? Did the responsibility lie within the G2 staff or the MI BN, or was it split between them?
8. How did you handle the training of the Analytical Control Element? Who was responsible for training? Who decided the METL?
9. How did you prepare yourself for the job mentally? Did you have any civilian education or non-military training which was advantageous?
10. Would the elimination of the SIGINT mission from the MI BN change your recommendations?
11. How critical do you think the Military Intelligence battalion (Heavy Division) is for leader development and promotion within the MI Corps?

Appendix B (Assistant Chief of Staff, G2 (S2), Intelligence

The G2(S2) is the principal staff officer for all matters concerning military intelligence (MI), counter-intelligence, security operations, and military intelligence training. An intelligence officer is located at every echelon from battalion through corps. Following are the areas and activities that are the specific responsibility of the G2(S2).

Military intelligence (MI)

- Disseminating intelligence to commanders and others in a timely matter.
- Collecting, processing, producing, and disseminating intelligence.
- Conducting and coordinating intelligence preparation of the battlefield (IPB).
- Recommending unit area of interest and assisting the staff in defining unit battlespace.
- Describing the effects of the battlefield environment on friendly and enemy capabilities.
- Determining enemy most probable and most dangerous course of action and key events.
- Coordinating with the entire staff and recommending PIR for the commander's critical information requirements.
- Integrating staff input to IPB products for staff planning, decision making , and targeting.
- Coordinating with the G3 (PM) for processing (for intelligence purposes) materials taken from EPWs and civilian internees.
- Coordinating ground and aerial reconnaissance and surveillance operations with other collection assets.
- Participating in targeting meeting.
- Debriefing personnel returning from enemy control.

- Analyzing, in coordination with the G3 (engineer coordinator [ENCOORD]), enemy capability to use environmental manipulation as a means to impede friendly forces or jeopardize long-term objectives.
- Coordinating technical intelligence activities and disseminating information.
- Assisting the G3 in planning target acquisition activities for collection of target information.
- Coordination with the chemical officer to analyze the enemy's capability and predictability of using nuclear, biological, and chemical (NBC) weapons.
- Coordinating with the G1 the enemy situation that may affect evacuation or hospitalization plans.
- Coordinating with the G4 the enemy situation that may affect logistics operations.
- Coordinating with the G5 the enemy situation that may affect civil-military operations.
- Assisting the G3 (deception officer) in preparing deception plans by recommending the target and objective based on assessed enemy collection capability and susceptibility to deception.
- Assisting the G3 in information operations, to include command and control warfare (C²W).
- Planning and managing intelligence collection operations in coordination with the G3 and fire support planners.
- Recording, evaluating, and analyzing collected information to produce all-source intelligence that answers the commander's priority intelligence requirements and information requirements (IR), including battle damage assessments (BDAs).
- Maintaining the current situation regarding the enemy and environmental factors updating IPB and the intelligence estimate.
- Determining map requirements and managing the acquisition and distribution of map and terrain products in coordination with the G3 (ENCOORD), who is responsible for map and terrain product production.

Counterintelligence (CI)

- Identifying enemy intelligence collection capabilities, such as human intelligence (HUMINT), signals intelligence (SIGINT), imagery intelligence (IMINT), and efforts targeted against the unit.
- Evaluating enemy intelligence capabilities as they affect the areas of OPSEC, countersurveillance, signals security (SIGSEC), security operations, deceptions planning, psychological operations (PSYOP), rear area operations, and force protection.
- Conducting counterintelligence liaison for security and force protection.
- Conducting counterintelligence force protection source operations.

Security operations

- Supervising the command and personnel security program.
- Evaluating physical security vulnerabilities to support the G3.
- Coordinating security checks for indigenous personnel.

Staff planning and supervision over the special security office.

Intelligence training

- Preparing the command intelligence training plan and integrating intelligence, counterintelligence, operational security, enemy (organization, equipment, and operations), and intelligence preparation of the battlefield considerations into other training plans.
- Exercising staff supervision of MI support to the command's intelligence training program.

Staff Weather Officer

- Coordination of staff responsibility for the staff weather officer (SWO). (The duties and responsibilities of the SWO can be found under the special staff officer section.)

Endnotes

¹ U.S. Department of the Army. *Field Manual 34-1. Intelligence and Electronic Warfare Operations*. (Washington, D.C.: Headquarters, 27 September 1994): 4-2. This term is continued in the draft version of FM 34-10. The first sentence in the staff mission chapter states "The G2 is the division's senior intelligence officer."

² Douglas A. Macgregor, *Breaking the Phalanx*. (Westport, CT: Praeger Publishers, 1997): 72. COL Douglas Macgregor proposed a combination C4I battalion. Macgregor's C4I battalion was not considered as a viable option. It must be remembered that COL Macgregor envisioned eliminating division level headquarters. His organization would not technically be able to support a heavy division. He envisioned a combination intelligence and signal unit called a C4I battalion. Although the idea of this unit is intriguing in its idea of combining, MI, NBC, Signal, FS, MP and ADA in a single unit, it is beyond the feasible now. It is not simply a matter of technology. The battalion relies on scarce overhead air-breathing and non-air-breathing assets such as JSTARS, UAVs and satellites to provide information. Sensors merely provide information. Humans must conduct analysis and synthesis to produce intelligence. Artificial intelligence software may provide tools to speed up the process, but experience and knowledge will still be required.

The battalion is not adequately resourced with analytical ability. Merely knowing where the enemy is located is helpful but not the end-state of intelligence. If you are fighting outnumbered, it is helpful to know what the enemy is capable of or what he is going to do. Situational awareness is not the end-all, be-all of intelligence collection.

It is also a matter of training leaders to command and control such organizations. How is the army going to train and retain officers in 16-22 years to command such complex organizations? The future commander would be a mere figurehead to the Combat Group or Division commander.

The C4I option does not meet the minimum requirements for Analysis and Present in the Force XXI intelligence tasks as outlined in TRADOC Pamphlet 525-75. There are insufficient intelligence personnel to adequately support analysis in current operations. This capability cannot be accomplished via split-based operations. Personnel of appropriate rank and experience must be present. We will not have artificial intelligence software that can turn information into intelligence or war-gaming products any time soon. Based on this failure to meet minimum requirements this option will not be considered.

³ James A. Neal, Jr., "From the Commander: CEWI-A Validated Concept?" *Military Intelligence* (October-December 1980): 2.

⁴ Joseph C. Wilson. "Reflections of a CEWI battalion Commander" *Military Intelligence* (October-December 1980): 3.

⁵ Macgregor's work proposes a combination of signal and military intelligence battalion. Another issue which arose was the need for separate military intelligence and signal battalions. Since the MI Battalion relies so much on communications to move information around, why not let the signal battalion take over the function of moving the data. Intelligence data is no different than any other sort of data. This question arises when the Commanding General of the Intelligence Center and School, MG Thomas, at Ft. Huachuca states to MI officers that he sees the role of the MI battalion commander is to ensure intelligence flows into the division from higher while the G2 integrates intelligence into the Military Decision Making Process (MDMP).

⁶ This problem or area of concern was noted by all participants in the interviews. Some participants had horror stories about how G2s and MI battalion commander would avoid walking on the same side of the street or even talking to one another. It was somewhat curious how the current officers are a team, but the former officers talk about real tension existing. The main problem seemed to be hurt feelings and pride about stepping in each other's responsibilities. The Division Commander, Chief of Staff and Assistant Division Commanders seemed to exacerbate this by not understanding the roles of the G2 and MI battalion commander. For example, the G2 gets blamed for faulty analysis when he does not own the ACE. This leads to conflicts with the MI battalion commander over the quality of training and priorities.

⁷ FM 34-1, 1-11.

⁸ *Ibid.*, 1-2. The first time the term “intelligence system” is used is on the second page of the manual. “From this broad baseline, commanders possess the capability to prioritize, focus, and surge the *intelligence system* (italics added) supporting the force projection operations. The commander plays a key role in mission-based intelligence and intelligence readiness. Since there is no longer one threat facing the U.S., command involvement is essential in ensuring that the *intelligence system* is focused on the commander’s top contingencies.” FM 34-1, p1-4, treats the terms Intelligence BOS and intelligence system differently when discussing one of the key principles of force projection IEW: The commander drives intelligence. “As shown in Figure 1-3, the commander must-..., Understand the capabilities and limitations of the intelligence BOS, Know how to leverage and employ the intelligence system to its full potential....”

⁹ *Ibid.*, 1-11.

¹⁰ *Ibid.*

¹¹ United States Department of the Army, *Field Manual 34-10 (Draft), Division Intelligence and Electronic Warfare Operations*. (Washington, D.C.: Headquarters, , 26 February 1998): 3-11.

¹² *Ibid.*, 5-1.

¹³ *Ibid.*, 5-8.

¹⁴ Joint Chiefs of Staff, *JCS Pub 2-0. Joint Doctrine for Intelligence Support to Operations* (Washington, D.C.: The Joint Chiefs of Staff, 12 October 1995): VII-1.

¹⁵ MI doctrine, http://huachuca-usaic.army.mil/SCHOOL/doc_pubs.html, 11 September 1998

¹⁶ Joseph Bolick, Former Commander, 522nd Military Intelligence Battalion, Interview by author, 26 October 1998, Transcript.

¹⁷ Field Manual 34-10 (Draft), 4-6.

¹⁸ *Ibid.*, 4-8.

¹⁹ The MI battalion has an XO, S1, S2, S3,S4, SIGO and BMO.

²⁰ The tasks the G2 will have to accomplish in Force XXI are found in TRADOC Pam 525-75, *A Concept for Force XXI Intel Ops*. Intel XXI is designed to provide commanders a knowledge based, prediction oriented capability which can meet the requirements of Force XXI. Intel XXI accomplishes this capability through seven tasks. These seven tasks supersede those tasks currently associated with the intelligence cycle. These new tasks are not cyclic like described in the current model. They are in line with the doctrinal intelligence tasks. The seven tasks are direct, collect, analyze, disseminate, present, attack and protect. Since these tasks and these definitions may not be familiar and the G2 and MI battalion commander will be expected to accomplish them, a short description of each task is necessary. They are the screening criteria for the four options.

In Force XXI, intelligence officers direct the full range of intelligence and RSTA assets to include organic, joint, national and multi-national sources. TRADOC Pam 525-75 states that S2s and G2 must act as their commander’s “Chief of Reconnaissance.” Directing involves asset visibility, synchronization, tasking, sensor to shooter linkages [sensor to sensor] and while using visual displays, artificial intelligence and automated synchronization matrices.

Collecting enables the commander to see their extended battlespace. Collection systems will be fewer, more modular and tailored to the mission. There will also be a greater emphasis on HUMINT. Collecting provides commanders intelligence, including terrain and weather needed to understand their battlespace and locate, identify and track critical targets.

Analysis must portray the situation so commanders can understand and act on the information. “Analysis converts battlespace data and information into intelligence and understanding to support effective decision-making.” Analysis rapidly turns information into understanding so those commanders can more effectively conduct decisive operations.

Dissemination is a critical link in the intelligence process. Intelligence is of little value if it does not get to the decision-maker in a timely manner. Dissemination takes place through a combination of push-pull systems. These "push-pull" systems are rapidly becoming more technologically advanced through better software and communications systems.

Present deals with creating an accurate and relevant high fidelity, intelligence picture of the battlefield. It includes current and future operations as well as war-gaming during the military decision-making process. This often entails tailoring the presentation of intelligence to a format desired by a commander. It is often non-standard and dependent on his command style.

Attack concerns using lethal and non-lethal means on High Payoff Targets. It is aimed at the opponent's command and control structure and decision-making process. It encompasses command and control warfare (C2W). Electronic attack shapes the battlespace for the commander.

Protect includes defensive and offensive actions. Offensive protect uses attack means to reduce the enemy's means to effect our C2. Defensive protect reduces friendly vulnerability.

²¹ The American Heritage Dictionary, 2nd College Edition, 539.

²² Ibid., 1068.

²³ United States Department of the Army, *FM 30-5, Combat Intelligence*, (Washington, D.C., Headquarters, Department of the Army, 27 June 1967) 28. FM 30-5 lists responsibilities of the G2 as follows "The Intelligence Officer is the principle staff officer assigned to assist the commander to carry out his intelligence and counter intelligence responsibilities. As such, the intelligence officer assists the commander (and staff) by furnishing intelligence which is needed to make decisions and plan operations. intelligence is provided by the intelligence officer through written reports, estimates and oral briefings."

²⁴ United States Department of the Army, *Field Manual 101-5, Staff Organization and Operations*, (Washington, D.C. Headquarters, Department of the Army, 31 May 1997): 4-10 - 4-11

²⁵ Field Manual 34-1, 4-2.

²⁶ One of the interviewers stated that when it had been brought up before senior MI officers in the past, the response was "They were both grown ups and to deal with it". He felt this was a very unsatisfactory answer to a doctrinal problem.

²⁷ United States Department of the Army, *Field Manual 71-100 Division Operations*. (Washington D.C., Headquarters, Department of the Army, 26 August 1996): 3-9.

²⁸ Field Manual 34-1, 4-3.

²⁹ Ibid., 4-2.

³⁰ Field Manual 34-10 (Draft), 3-9.

³¹ Gary C. Phillips, Former Commander, 104th Military Intelligence Battalion. Interview by author, 28 October 1998, Fort Leavenworth, KS. Tape recording.

³² John Stewart F, Jr., *Operation Desert Storm, The Military Intelligence Story: A View from the G-2, 3rd Army*. (Riyadh, Saudi Arabia: 3rd U.S. Army, April 1991): 36. "Finally, it is clear that having an MI unit with a commander and staff working in support of G-2 is a doctrinal tenet that MI must hold. The G-2, in his role as senior intelligence officer for the commander, must have the freedom to direct, manage, produce, analyze, program and staff. It is the MI unit commander who trains, task organizes, and implements"

³³ Thomas H. Felts, *Building a Tactical Intelligence Model for the Information-Based Force* (SAMS Monograph, 18 December 1997): 32

³⁴ J.R Bondanella, E.M. Cesar, Jr., P.D. Allen, P. Propper, and C. L., *Shipbaugh Estimating the Army's Intelligence Requirements and Capabilities for 1997-2001* (Santa Monica, CA: Rand, 1993): xxvii. The Rand study questioned the need for tactical SIGINT at Corps level and SIGINT demonstrated serious

problems with fluid situations on the battlefield. It recommended keeping a ground-based system in the division to augment airborne means when weather turned bad and the situation turned static. It found that airborne collection was superior in all other aspects. There was also limited use in stability and support operations. MG Thomas made his comments to meeting of MI officers at Command and General Staff College. BG Hall made his comments to a briefing of officers from the School of Advanced Military Studies.

³⁵ Gus Greene, Commander, 104th Military Intelligence Battalion, Interview by author, 25 September 1998, FT Leavenworth, KS. Transcript. This term was best described by LTC Gus Greene during his interview and in his letter to the author. LTC Greene referred to it as making the "call".

³⁶ This point is critical. A poorly trained operator on the ASAS and faulty updating of the database lowers the quality of the entire system. Standards must be developed and enforced. This is becoming more important with digitization and ASAS's possible integration with the Battlefield Planning and Visualization (BPV) system. The MI Battalion commander is the individual who can enforce these standards since he owns the assets.

³⁷ Steven Rotkoff, Former G2, 1st Cavalry Division, Interview by author, 19 November 1998, Fort Leavenworth, KS. Tape recording. LTC Rotkoff suggested that an even better place for it was back under the control of the G2 in the Headquarters Company of the Division. He felt this would eliminate any problem of who owned the ACE by establishing a clear rating chain. Given the current trend to keep headquarters as small as possible this option was not considered viable at this time. There is also the problem of dividing up the personnel and systems which comprise the ASAS system. The G2 would own a portion of the systems while the MI battalion would own the rest. Training and automation protocol difficulties would be increased.

³⁸ Field Manual 101-5, 4-26. "The Fire Support Coordinator (FSCOORD) is the special staff officer for coordinating fire support and field artillery assets and operations in the command. The FSCOORD is the senior field artillery officer in the force. The assistant or deputy is a permanent staff officer representing the FSCOORD in his absence." The DIVARTY has a COL Commander, LTC Executive Officer, LTC operations officer, and officers in the plans and Tactical Command Post. He also has LTCs commanding all of his subordinate units which lessen the strain.

³⁹ Deleting the Military Intelligence battalion would be a huge step for the MI Corps. It is seen by some as the MI Corps' crowning achievement of the past twenty years. There is a battalion to command that assigns an intelligence unit under the command of a division commander on a permanent basis. Success in the MI Corps is still built upon branch qualifying jobs in tactical assignments. This option would eliminate three positions that the rest of the U.S. Army recognizes: Battalion Commander, Executive Officer and operations Officer.³⁹

Although leader development and command opportunities for Military intelligence officers is important, it should not be the overriding factor in keeping the current lieutenant colonel command position in the MI battalion. Military Intelligence officers and their systems primary responsibility is to provide intelligence to the commander in a way that is timely relevant, specific and accurate.

The increase in systems capabilities and communications and intelligence architecture makes this possible. The heavy division does not lose systems or capabilities. They are assigned to other units for maintenance and troop support. There would still be OPCON and tasking relationships to the G2.

⁴⁰ There seems to be a problem in recruiting former MI battalion commanders to become G2s. Although this is hard to be prove factually, enough anecdotal evidence exists to raise serious concerns. BG Hall discussed the subject with MI officers and SAMS officers during his briefings on the future of Military Intelligence on 20 August 1998. The subject came up during interviews with former battalion commanders who were aware of other officers who avoided G2 jobs once they were non-select for battalion command. These non-select officers knew that the G2 was a difficult job, but no matter how well they did it they could not be selected for the War College.

⁴¹ The G2 will be the most experienced MI officer if had been assigned to the appropriate positions in the MI battalion, been assigned as a maneuver Brigade S2 and held MI battalion command.

⁴² Although it seems at cross purposes to assign the G2 the responsibility for the intelligence while the MI Battalion commander is responsible for the intelligence architecture while it was stated earlier that the architecture is part of the system, this not the case. The G3 is responsible for and designs an operations plan of which the fire support plan is an integral part. The DIVARTY commander is then held responsible for the execution of the fire support plan.

Bibliography

Books

- Bondanella, J.R., E M Cesar, Jr. P.D. Allen, P. Propper, and C. L. Shipbaugh. *Estimating the Army's Intelligence Requirements and Capabilities for 1997-2001*. Santa Monica, CA: Rand, 1993.
- Cesar, Edison, Patrick Allen, Steven Bankes, John Bondanella, Rick Eden, H. Edward Hall, Clairice Veit, Loretta Verma, Robert Weissler, and Barry Wilson. *A New Approach for Measuring the Operational Value of Intelligence for Military Operations*, Santa Monica, CA: Rand, 1994.
- Macgregor, Douglas A. *Breaking the Phalanx*. Westport, CT: Praeger Publishers, 1997
- Stewart, John F., Jr. *Operation Desert Storm, The Military Intelligence Story: A View from the G-2, 3rd Army*. Riyadh, Saudi Arabia: 3rd U.S. Army, April 1991.

Articles

- Baker, Daniel F. "Deep Attack: A Military intelligence Task Force in Desert Storm. *Military intelligence* (October-December 1991): 39-42.
- Bell, J. Lloyd Jr., Alexandra M. Hoffner, Lynn T. Merrel and Michael D. Woods. "The New DS MI Company: Applying Technology to Defeat the Enemy." *Military Intelligence* (October-December 1997):
- Brady, Michael D. "Intelligence Operations on the Digitized battlefield" *Military Intelligence* (July-September 1997): 23-25.
- Brooks, John R. "The Results of TF XXI AWE Are In—Things Are A-Changin" *Military Intelligence* (July-September 1997): 9-10.
- Brooks, John R. and Steven L. Campbell. "The EXFOR: Intelligence in Force XXI." *Military Intelligence* (April-June 1996): 14-18.
- Cabeen, Jules P. Jr. and Brian R. Dunmire. "Alternative Change in the Force XXI GS MI Company." *Military Intelligence*. (July-September 1996): 25-28.
- Chopin, Theodore G. "ASAS System update and planned RWS Fielding and Institutional Support." *Military Intelligence* (October-December 1996): 49-50.
- Dickey, Gary Don. "AWE intelligence Communications Architecture: The Division ACE Battle Captain" *Military Intelligence* (July-September 1997): 18-19.
- Eichelberger, Charles B. "The MI Corps A Vision of the Future." *Military Intelligence* (October-December 1991): 7-13.
- Hallagan, Robert F. "An introduction to our intelligence Branch Operational Concept." *Military Intelligence* (January-March 1993): 6-15.
- Harris, H. Brock. "Building a DS MI Company" *Military Intelligence* (October-December 1997): 40-43.
- Lady, John F. III. "Directing Intelligence operations IV: Intelligence Battle Command." *Military Intelligence* (October-December 1997): 24-28.
- LaPorte, Leon J. and Gus E. Greene, Sr. "First Team intelligence Support to the 1st Cavalry Division" *Military Intelligence* (October-December 1997): 6-7.
- Madden, Patrick M. and Robert Hallagan. "Army Intelligence Split-Based Operations." *Military Intelligence* (April-June 1994): 5-8.
- Martinez, Erasmo A. "Division XXI Intelligence Operations." *Military Intelligence*, (April June 1996): 19-22.
- Neal, James A. "From the Commander: CEWI—A Validated Concept?" *Military Intelligence* (October-December 1980): 2.
- Owens, Ira C. "Army intelligence Operations in Force XXI." *Army* (October 1994): 45-149

- Perkins, Stephen P. "Force Tailoring: Deploying the G2's piece of the Assault Command Post" *Military Intelligence* (October-December 1997): 48-50.
- Phillips, Gary E. "Intelligence to the point of the spear." *Military Intelligence* (April-June 1995): 22-24.
- Ryan, Keith. The MI Revolution: The Analysis and Control Element (ACE) and the All-Source Analysis System (ASAS)." *Military Intelligence* (July-September 1994): 19-25.
- Stapleton, David. "Brigade Intelligence Systems tested at ODC II." *Military Intelligence* (July-September 1994): 16-18.
- Turner, Albert F. "On the path to the Digital Division: Force XXI and the AWES" *Military Intelligence* (July-September 1997): 11-13.
- Wilson, Joseph C., "Reflections of a CEWI battalion Commander" *Military Intelligence*(October-December 1980): 3.

Government Manuals

- Field Manual 34-1. *Intelligence and Electronic Warfare Operations*. Washington, D.C.: Headquarters, Department of the Army. 27 September 1994.
- Field Manual 34-3, *Intelligence Analysis*. Washington, D.C.: Headquarters, Department of the Army, 15 March 1990.
- Field Manual 34-8, *Combat Commander's Handbook on Intelligence* Washington, D.C.: Headquarters, Department of the Army, 28 September 1992
- Field Manual 34-10, *Division Intelligence and Electronic Warfare Operations*. Washington, D.C.: Headquarters, Department of the Army, November 1986.
- Field Manual 34-10 (Draft), *Division Intelligence and Electronic Warfare Operations*. Washington, D.C.: Headquarters, Department of the Army, 26 February 1998.
- Field Manual 71-100, *Division Operations*. Washington D.C., Headquarters, Department of the Army, 26 August 1996
- Field Manual 100-5. *Operations*. Washington, D.C.: Headquarters, Department of the Army, June 1993.
- Field Manual 101-5, *Staff Organization and Operations*, Washington, D.C. Headquarters, Department of the Army, 31 May 1997
- Field Manual 101-5-1. *Operational Terms and Symbols*. Washington, D.C.: Headquarters, Department of the Army, January 1994.
- TRADOC Pamphlet 525-XX. *Force XXI Division Operations Concept*. Fort Monroe, VA: TRADOC, 19 May 1995, <http://www-tradoc.army.mil/tpubs/pams/p525-75.htm>, 6 October 1998.
- TRADOC Pamphlet 525-75, *A Concept for Force XXI Intel Opns*, Fort Monroe, 1 November 1996, <http://www-tradoc.army.mil/tpubs/pams/p525-75.htm>, 6 October 1998
- Defense Science Board. "Improved Application of Intelligence to the Battlefield", http://www.fas.org/irp/program/dsb_battlefield_rep.htm, 23 July 1998
- Joint Chiefs of Staff, *JCS Pub 2-0. Joint Doctrine for Intelligence Support to Operations* Washington, D.C.: The Joint Chiefs of Staff, 12 October 1993
- Table of Organization and Equipment, <http://www.usafmsaradd.army.mil/products/toeindex.htm>, 11 September 1998
- Table of Organization and Equipment, *Heavy Division HHC*, <http://www.usafmsaradd.army.mil/toe.cfm?toenumber=87004A100>, 20 November 1998.
- Table of Organization and Equipment, *Force XXI Heavy Division HHC*, <http://www.usafmsard.army.mil/scripts/fmss/testtoe.dll/TOEDetail?TOENumber=87004F100&CIassType=%25&PARNUM=003>, 10 October 1998
- MI doctrine, http://huachuca-usaic.army.mil/SCHOOL/doc_pubs.html, 11 September 1998

Monographs

- Felts, Thomas H. "Building a Tactical Intelligence Model for the Information-Based Force" SAMS Monograph, 18 December 1997.
- Hammond, John C. "Army Intelligence Future (AIF): An Alternative to CEWI." Student Paper Newport, RI: U.S. Naval War College, 26 June 1990.
- Kellar, Brian A "Seeing the AirLand Battlefield: Can the Heavy Division Military Intelligence Battalion Do Its Job?" Student Monograph. Fort Leavenworth, KS: School of Advanced Military Studies, 1991.
- Quirk, Richard J, III "Intelligence for the Division: A G2 Perspective." Student Paper. Carlisle Barracks, Pennsylvania: U.S. Army War College, 1992.

Interviews

- Bolick, Joseph, Former Commander, 522nd Military Intelligence Battalion, Interview by author, 26 October 1998, Fort Leavenworth, KS. Transcript.
- Rotkoff, Steven, Former G2, 1st Cavalry Division. Interview by author, 19 November 1998, Fort Leavenworth, KS. Tape recording.
- Phillips, Gary C., Former Commander, 104th Military Intelligence Battalion. Interview by author, 28 October 1998, Fort Leavenworth, KS. Tape recording.
- Greene, Gus, 104th Military Intelligence Battalion Commander, Interview by author, 25 September 1998, Fort Leavenworth, KS. Transcript.

Letters

- Bolick, Joseph, Former Commander, 522nd Military Intelligence Battalion, to author via electronic mail, 16 October 1998, Fort Leavenworth, KS.
- Greene, Gus, Commander, 104th Military Intelligence Battalion, to author via electronic mail, 20 September 1998, Fort Leavenworth, KS.
- Leeder, Steve, to author via electronic mail, 7 October 1998, Fort Huachuca, AZ.
- Parish, Gary L., G2, 3rd Infantry Division, to author via electronic mail, 19 November 1998, Fort Stewart, Georgia.
- Perkins, Stephen P., Commander, 103rd Military Intelligence Battalion, to author via electronic mail, 20 November 1998, Fort Stewart, Georgia