

AD _____

GRANT NUMBER DAMD17-94-J-4307

TITLE: Genetic Alterations in Familial Breast Cancer: Mapping
and Cloning Genes Other Than BRCA1

PRINCIPAL INVESTIGATOR: Mary-Claire King, Ph.D.
Warren Winkelstein, Jr., M.D., M.P.H.

CONTRACTING ORGANIZATION: University of California
Berkeley, California 94720

REPORT DATE: September 1998

TYPE OF REPORT: Final

PREPARED FOR: Commander
U.S. Army Medical Research and Materiel Command
Fort Detrick, Frederick, Maryland 21702-5012

DISTRIBUTION STATEMENT: Approved for public release;
distribution unlimited

The views, opinions and/or findings contained in this report are those of the author(s) and should not be construed as an official Department of the Army position, policy or decision unless so designated by other documentation.

DTIC QUALITY INSPECTED 4

19990811 109

REPORT DOCUMENTATION PAGE

Form Approved
OMB No. 0704-0188

Public reporting burden for this collection of information is estimated to average 1 hour per response, including the time for reviewing instructions, searching existing data sources, gathering and maintaining the data needed, and completing and reviewing the collection of information. Send comments regarding this burden estimate or any other aspect of this collection of information, including suggestions for reducing this burden, to Washington Headquarters Services, Directorate for Information Operations and Reports, 1215 Jefferson Davis Highway, Suite 1204, Arlington, VA 22202-4302, and to the Office of Management and Budget, Paperwork Reduction Project (0704-0188), Washington, DC 20503.

1. AGENCY USE ONLY <i>(Leave blank)</i>	2. REPORT DATE September 1998	3. REPORT TYPE AND DATES COVERED Final (15 Aug 94 - 14 Aug 98)	
4. TITLE AND SUBTITLE Genetic Alterations in Familial Breast Cancer: Mapping and Cloning Genes Other than BRCA1		5. FUNDING NUMBERS DAMD17-94-J-4307	
6. AUTHOR(S) Mary-Claire King, Ph.D. Warren Winkelstein, Jr., M.D., M.P.H.			
7. PERFORMING ORGANIZATION NAME(S) AND ADDRESS(ES) University of California Berkeley, California 94720		8. PERFORMING ORGANIZATION REPORT NUMBER	
9. SPONSORING / MONITORING AGENCY NAME(S) AND ADDRESS(ES) U.S. Army Medical Research and Materiel Command Fort Detrick, Maryland 21702-5012		10. SPONSORING / MONITORING AGENCY REPORT NUMBER	
11. SUPPLEMENTARY NOTES			
12a. DISTRIBUTION / AVAILABILITY STATEMENT Approved for Public Release; Distribution Unlimited		12b. DISTRIBUTION CODE	
13. ABSTRACT <i>(Maximum 200 words)</i> The purpose of this project was to identify genes responsible for inherited predisposition to breast cancer in families. The gene PTEN was successfully cloned by this project, and simultaneously by others (for a different reason) and proved to be such a gene. This project indicated that inherited mutations in PTEN predispose to breast cancer in women with the rare Cowden's syndrome. However, symptoms of that syndrome may be very subtle, so breast cancer may be the first sign to appear. Inherited mutations in PTEN predispose to multiple other cancers that may appear with breast cancer in these patients. Also, this project demonstrated the value of patients with germline translocations and breast cancer for the identification of tumor suppressor genes.			
14. SUBJECT TERMS Breast Cancer		15. NUMBER OF PAGES 26	
		16. PRICE CODE	
17. SECURITY CLASSIFICATION OF REPORT Unclassified	18. SECURITY CLASSIFICATION OF THIS PAGE Unclassified	19. SECURITY CLASSIFICATION OF ABSTRACT Unclassified	20. LIMITATION OF ABSTRACT Unlimited

GENETIC ALTERATIONS IN FAMILIAL BREAST CANCER:
MAPPING AND CLONING GENES OTHER THAN BRCA1

TABLE OF CONTENTS

Front cover	1
SF298, Report documentation page	2
Foreword	3
Table of contents	4
Introduction	5
Body	7
Conclusions	16
References	17
Appendix 1	19
Bibliography	26
Personnel	26

GENETIC ALTERATIONS IN FAMILIAL BREAST CANCER: MAPPING AND CLONING GENES OTHER THAN BRCA1

INTRODUCTION

Despite the importance of BRCA1 and BRCA2 to inherited breast cancer, it is clear that there remain families with multiple cases of breast cancer with no identified BRCA1 or BRCA2 mutations (after screening the entirety of both genes) and no apparent linkage of breast cancer to either 17q21 or 13q12 (see our 1995 progress report; Schubert et al. 1997; Czabo and King 1997). The goal of project DAMD17-94-J4307 was to identify genes responsible for inherited breast cancer in these and other "unexplained" families. In the course of carrying out a genome-wide screen for linkage in these families, it became clear that the frequent combination of late age at breast cancer onset and small family size would limit the statistical power of linkage analysis. Therefore, we decided to integrate linkage analysis with the analysis of germline chromosomal abnormalities that might predispose to breast cancer.

In order to identify germline chromosomal abnormalities that might alter breast cancer genes, we sought patients who had both very early onset breast cancer and developmental abnormalities. It was our hypothesis that this combination of phenotypes would often reflect de novo, germline chromosomal rearrangements in genes critical to breast cancer, as well as of genes critical to normal development. The most promising case discovered so far in this search was that of a young woman (LP) with early bilateral breast cancer in the context of Cowden's syndrome and a complex de novo rearrangement of chromosomes 10q, 2q, and 13q.

Although Cowden disease is rare, it was our hypothesis that the Cowden disease gene might influence breast cancer risk in families other than those with Cowden disease. It is well-documented that some mutations in a gene may lead to a very severe phenotype and other mutations in the same gene to a more restricted phenotype. The high frequency of breast cancer in female Cowden patients (~30%)

makes it a strong candidate for a breast cancer susceptibility gene (Hanssen and Fryns 1995).

Cowden's disease is a multiple hamartoma syndrome with an autosomal dominant pattern of inheritance (Weary et al. 1972), originally described in the family of Rachel Cowden (Lloyd and Dennis 1963). Cowden disease is characterized by multiple nodules of the skin and mucous membranes, fibromas of breast and thyroid, and gastrointestinal polyps (Brownstein et al. 1977). Mental retardation, macrocephaly, seizures, and ataxia are frequently involved. Although Cowden syndrome has traditionally been defined by skin lesions, it also involves cancer of internal organs, most frequently thyroid and breast.

From the outset of this project, we were aware that breast cancer frequently occurs in the context of Cowden's disease (Walton et al. 1986). In seven families with 21 cases of Cowden disease, inheritance was autosomal dominant with high penetrance and high frequency of breast cancer in females, craniomegaly, gastrointestinal polyps, and fibromas (Starink et al. 1986). In another Cowden disease family, the proband had multiple papillomas and was diagnosed at age 32 with breast cancer. Her mother died of breast cancer at age 42, and 2 maternal aunts had premenopausal breast cancer (Williard et al. 1992). In still another large Cowden disease family, there was greater disease severity and earlier onset in successive generations (Hanssen et al. 1993).

Our efforts to clone genes spanning the translocation breakpoints of LP were supported by DAMD17-94-J4307. After the critical gene PTEN was cloned (Li et al. 1997, Steck et al. 1997), we characterized the role of PTEN in inherited predisposition to breast cancer (Lynch et al. 1997; included in this report). We examined potential interactions between PTEN and mismatch repair genes or between PTEN and thyroid cancers. Cloning and characterization of the PTEN gene and its interactions form the body of this report.

BODY OF REPORT

Cloning translocation breakpoints on chromosome 10q

In an effort to clone the gene responsible for Cowden's syndrome, we identified a patient with Cowden's syndrome and an abnormal karyotype. Cytogenetic analysis of LP chromosomes indicated a complex chromosomal rearrangement involving 2q, 10q, and 13q. Following the publication of linkage for Cowden's syndrome to chromosome 10q23-q24 (Nelen et al. 1996), we concentrated molecular analysis on the chromosome 10q breakpoint. STSs for genetic markers flanking and within the Cowden's critical region were used to isolate BAC clones by PCR screening of commercially available DNA pools (Research Genetics, Inc.) A list of BACs identified by this STS screening and their location on the translocated chromosomes is shown in Table 1. These BACs were then used to further characterize the translocation breakpoints, as described below.

Our analysis by fluorescence in situ hybridization (FISH) revealed that LP's chromosome 10q23 breakpoint was within the Cowden's disease region defined by linkage (Table 1). Marker AFMa086wg9 identified BAC 151F15 which by FISH analysis of LP chromosomes was distal to the der10 breakpoint. Marker D10S215 identified BAC 336J2 which by FISH analysis was proximal to the der10 breakpoint. Marker D10S215 also identified BAC 200C8 which by FISH was proximal to the der10 breakpoint and showed a faint signal on the der2 chromosome at 2q33.3. This result was unexpected. The ends of BAC 200C8 were sequenced and PCR primers developed. PCR primers specific to the T7 end of BAC 200C8 were used to screen the BAC DNA pools. BACs 101I13 and 380E3 were positive for BAC 200C8T7 primers. FISH analysis of B101I13 indicated a strong hybridization signal on the der10q23.3 and on der 2q33.3, confirming the earlier result with BAC 200C8. Fish analysis of BAC 380E3 showed a strong hybridization signal on der 2q33.3 and on der13q14.1. Taken together this data indicates that the patients chromosome 10q rearrangement involved

chromosomes 2, 10, and 13 and that a submicroscopic portion of chromosome 10 was present on the der2 chromosome at the point of translocation.

PCR primer pair 151F15.SP6, specific to the SP6 end of BAC 151F15, was developed and tested against all other BACs identified in this study. 151F15.SP6 amplified BAC 151F15 and BAC 380E3. Hence we had identified a BAC contig across both chromosome 10 breakpoints from proximal marker D10S215 to distal marker AFMa086wg9 (Table 1).

Table 1. Contig of BACs in Cowden's region of chromosome 10q23.3

	BACs								
	336J2	200C8	101113	380E3	151F15	288D12	328G18	81N3	290C21
	<u>Minimal contig including CD gene</u>								
D10S215	X	X							
200C8.T7		X	X	X					
151F15.SP6				X	X				
AFMa086wg9					X				
D10S541						X			
WI-8733							X		
D10S564								X	X
position relative to breakpoint on LP chromosome 10	proximal	proximal	proximal	proximal	distal	distal	distal	distal	distal
position on LP chromosome der2			der2	der2					

Candidate genes for Cowden's Disease

To identify genes in this contig, whole BACs 101I13 and 380E3 were sonicated and shotgun subcloned into M13mp18. Sample sequencing of these two BACs included 768 individual M13 subclones from BAC 101I13 and 480 individual M13 subclones from BAC 380E3. For these two BACs approximately 80% of the inserts contained human sequences, 13% contained E coli DNA, 5% contained BAC vector DNA only, and 2% contained no insert. The insert sizes for BACs 101I13 and 380E3 are 150Kb and 90Kb respectively, as determined by PFGE analysis of NotI digested BAC DNA. The total amount of novel sequence identified for BACs 101I13 and 380E3 was 220 kb. Analysis of contigs generated from this sequence indicates that only one contig of sequence is shared between these two BACs. The amount of DNA sequence shared by BACs 101I13 and 380E3 is roughly 5 kb. Of the possible 245 kb of genomic sequence, our sample sequencing identified approximately 220 kb which is divided into 93 individual contigs ranging in size from 650 bp to 8.2 kb with an average size of 2 kb.

Chromatograms from M13 subclones of BACs were base-called by Phred, and contigs generated using Phrap (P. Green, unpublished), repetitive elements were masked by RepeatMasker (A.Smit, unpublished), and the subsequent sequence was used to search the non-redundant and EST databases at the NCBI. We developed a program to automate this sequence analysis called "SeqHelp" which generates output in HTML format (Lee et al., in press). The BLAST analysis of BAC sequences revealed numerous EST hits and several hits on the non-redundant database. In the cases where ESTs were identified to share a high degree of sequence similarity with the genomic sequences derived in our lab, that EST or cluster of ESTs was used for an iterated BLAST search and to search against the Unigene database. Where possible, a minimal tiling path of ESTs for a particular gene was identified and those clones were obtained from Research Genetics. Upon arrival, each IMAGE consortium EST was verified by sequencing in the forward and reverse directions. A compilation of ESTs

and genes identified by this sample sequencing strategy is shown in Table 2. In total, this strategy identified one probable pseduogenes, two known genes, and eight novel genes.

Table 2. Clones for Cowden's region.

Soares libraries in T7T3D: retina (HR), melanocyte (HM), heart (HH19W), liver/spleen (FLS), placenta (HP), lung (HL19W)

Other libraries: Morton fetal cochlea; Stratagene colon, fetal spleen 937205, liver 937224, lung 937210

Sibiling contigs: 87-3, 101-97-100-103-104-109, 107-106-108, 110-18-29-32, 96-57-73, 31-63-55-91

Candidate gene	Contig	EST	IMAGE	clone	Genbank 5'	Genbank 3'	Library	Size	Rcvd	BAC bin	Repeat	T7 seq	T3 seq	maps back	Sthn blot	cDNA lifts	Comments
1	87	yd10e12	66766	T67647	T64918	1NFLS	1400	11.27	1	no	X	X	YES				same as yd77f12
	87	yd77f12	114287	T86559	T86737	1NFLS	1400	11.27	1	no	X	X	YES	Y			
	87	yu09a07	233268	H78837	H80084	1NFLS	na	11.27	1	Flama	X	X	NO				
2	95	yj22f11	149517	M00274	none	Nb2HP	900	11.27	1	no	X	X	YES	Y			no hits
3	110a	zb58e04	307806	W21284	none	NbHL19W	1528	11.27	1	yes	X	X	YES	Y			HIT
	110b	ys82e12	221326	H92038	H92039	N2b4HR	897	11.27	1	yes	X	X	YES	Y			
	110c	yx44f06	264611	N29304	N20238	2NbHM	1521	11.27	1	no	X	X	YES	Y			HIT
	110c	ze39e04	361374	AA017584	AA017563	N2b4HR	1200	11.27	1	no	X	X	YES	Y			
	110c	zf07g02	376274	AA041238	AA040800	NbHH19W	450	11.27	1	no	X	X	YES	Y			similar to MN1?
	110d	ze66g12	364006	AA021528	AA021529	N2b4HR	2100	11.27	1	no	X	X	YES	Y			similar to auxilin
110d	zf57b09	381017	none	AA057423	N2b4HR	2100	11.27	1	no	X	X	YES	Y			similar to auxilin	
4	31	mh88e08	458054	AA028745	none	NbMP13.5	na	1.18	3		X	X	Y	ND			MSP1 (mouse)
5	45	yc36e01	82776	T73612	none	liver	na	1.18	3		X	O					
6	74	ys11a12	214462	H71498	H71499	1NFLS	1040	1.18	1+2		X	X	Y	ND			
	74	za50h09	296033		N67051	1NFLS	na	1.18	1+2		X	X	Y	ND			
7	88	ys84c09	221488	H92144	none	N2b4HR	na	1.18	3+2	L1	X	X	Y				
8	90	yw71d12	257687	N40032	N27294	2NbHP	na	1.18	2		X	X	Y				
	90	yd44g03	111124	T83552	T82265	1NFLS	793	1.18	2		O	O	Y				
9	101	mb88g05	336536	W18519	none	p3NMF19.5	na	1.18	2		X	X	Y				ATP sulfurylase
	101	yb81c09	77584	T58926	T58867	liver	2275	1.18	2		O	X					ATP sulfurylase
	101	yc86b10	22836	T75047	R45266	1NIB	1617	1.18	2		O	O					ATP sulfurylase
	101	yi08f10	138667	R63483	R63484	Nb2HP	1789	1.18	2		O	O	Y				ATP sulfurylase
	101	yq76h07	201757	R99758	R99935	1NFLS	1339	1.18	2		X	X	Y				ATP sulfurylase
	101	yt65f04	275454	R84938	none	N2b4HR	2365	1.18	2		X	X	Y				ATP sulfurylase
	101	yw36g11	254372	none	N22190	cochlea	na	1.18	2		no	X	X	Y	Y		ATP sulfurylase
	101	yx09h10	261283	none	H98126	2NbHM	na	1.18	2			X	X	Y			ATP sulfurylase
	101	zb49a03	306892	W24271	N91940	NbHL19W	na	1.18	2			X	X	Y			ATP sulfurylase
	101	zc38a02	324554	W46906	W46759	NbHSF	na	1.18	2			X	X	Y			ATP sulfurylase
	101	zc38a08	324566	W46911	none	NbHSF	na	1.18	2			X	X	Y			ATP sulfurylase, CpG
	101	zc39c06	324682	W47234	none	NbHSF	na	1.18	2			X	O	Y			ATP sulfurylase
	101	zc41e07	324900	W49748	W49664	NbHSF	na	1.18	2			X	X	Y			ATP sulfurylase
	101	zh69d06	417323	W88929	W89186	1NFLS	na	1.18	2			X	X	Y			ATP sulfurylase
	101	zl69e07	509892	AA054697	AA056460	colon	na	1.18	2			X	X	Y			ATP sulfurylase, CpG
	101	zo92a06	594322	AA169652	AA169832	ovarian	na	1.18	2			X	X	Y			ATP sulfurylase
	101	zr40b09	665849	AA193419	none	NhMPaS1	na	BO	2			X	O				ATP sulfurylase
10	105	yx89a10	268890	N35829	none	2NbHM	na	1.18	1		X	O	N?				cofilin (5q13)
	105	za83a07	299124	W05247	N75449	NbHL19W	na	1.18	1		X	X	Y	Y			cofilin (5q13)
	105	zd69b06	345875	W77755	W72026	NbHL19W	na	1.18	1		X	O					cofilin (5q13)
11	107	yf99e02	30466	R18232	R42168	1NIB	1741	1.18	3		X	X	Y				alpha tubulin (K00558)
	107	yh15f04	37775	R61426	none	1NIB	na	1.18	3		X	X	Y				alpha tubulin (K00558)
	107	yl72d11	43584	H13396	H06059	1NIB	1464	1.18	3		X	X	Y				alpha tubulin (K00558)
	107	yl90b12	45452	H10475	H09719	1NIB	1785	1.18	3		O	O	?				alpha tubulin (K00558)
	107	yo18d05	178281	H46838	none	N2b5HB55Y	828	1.18	3		O	O	N				alpha tubulin (K00558)
	107	yx48f04	264991	N30486	none	2NbHM	na	1.18	3		X	X	Y	Y			alpha tubulin (K00558)
	107	yy40e11	273740	N44865	N33383	2NbHM	na	1.18	3		X	X	N				alpha tubulin (K00558)
	107	yz18a02	283370	N57579	N52758	2NbHMSP	na	1.18	3		X	X					alpha tubulin (K00558)
	107	zb94g08	320510	W31769	W04668	NbHPA	727	1.18	3		X	X	Y				alpha tubulin (K00558)
	107	zc06f03	321533	W32662	W32476	NbHPA	1650	1.18	3		X	X	Y				alpha tubulin (K00558)
	107	ze66f12	363983	AA021513	none	N2b4HR	na	1.18	3		X	X	Y	Y			no hits
	107	zo72a10	592410	AA158531	AA158532	pancreas	na	1.18	3		X	O	Y				alpha tubulin (K00558)

Mutations in candidate genes

To search for mutations in candidate genes, we first probed Southern blots of genomic DNA from LP and control individuals. No abnormal restriction patterns or band intensities were observed. Next we evaluated each gene in the region using SSCP to detect small sequence changes. We had collected DNA from 12 different Cowden's families including the translocation patient, all of which were to be examined using SSCP.

During the course of searching for mutations in the candidate genes from Table 2, two reports were published of a putative tyrosine phosphatase, PTEN, on chromosome 10q23 that is deleted in late stage tumors (Li et al. 1997, Steck et al. 1997). This gene corresponds to **Candidate Gene 3** of Table 2. Reports of the role of PTEN in cancer, and immediately thereafter in Cowden's syndrome (Nelen et al. 1997), prompted us to look more closely at this gene in our Cowden's syndrome families.

We screened all Cowden's syndrome families by sequencing PTEN exons from genomic DNA. Mutations were identified in seven families which are likely to be the cause of Cowden's syndrome in these patients. We did not identify any PTEN sequence changes or rearrangements in LP. Our characterization of PTEN in families with breast cancer and Cowden's syndrome was published in American Journal of Human Genetics, which is included as the next section of this report.

Genetic analysis of epistatic interaction between PTEN and mismatch repair genes.

Can de novo germline mutations of PTEN occur as a result of mismatch repair defect and present clinically as isolated cases of Cowden syndrome? Among the families with Cowden syndrome a subset of these families have a history of early onset cancer including colon, kidney and endometrial cancers, malignancies which are not typically associated with Cowden syndrome. We identified mutations of PTEN, determined whether the mutations were de novo, examined tumor samples for microsatellite instability, tested for linkage of mismatch repair genes in families with co-occurrence of early onset gastrointestinal cancer / Cowden syndrome and screened for germline mutations in DNA mismatch repair genes.

Family 241

Family 241 contains two members with Cowden syndrome and a history of small intestine and colon carcinoma. Linkage studies were performed in the region of 10q22-23 and subsequent sequencing of the nine exons of PTEN identified a nonsense mutation in the two affected individuals. (Lynch et al., 1997) No PTEN mutations were identified in any other living family members within this family including the mother of the proband. The father of the proband was deceased at the time that DNA was collected from this family. To determine if the proband's germline PTEN mutation was a de novo one, we obtained a colon cancer biopsy from the father of the proband. Genomic DNA was prepared from this biopsy and subsequently, a modified nested PCR primer strategy was used to amplify the portion of exon 8 containing the mutation. Subsequently, fluorescent thermocycle sequencing was used to determine the DNA sequence from the PCR product. No mutation was identified in the father of the proband, demonstrating that the mutation in the proband was truly de novo.

Given the early onset of small intestinal adenocarcinoma in the proband (age of onset at 32) and the presence of colon cancer and polyps in other immediate family members, we analyzed sections of his tumor for evidence of microsatellite instability. Genomic DNA was prepared microdissected tumor material. Loss of DNA mismatch repair function in his tumor was determined using a standardized set of mononucleotide and dinucleotide markers which are highly specific and sensitive for the detection of microsatellite instability and indicate lost activity of hMSH2 or hMLH1 (Dietmaier et al., 1998). There was no evidence of any microsatellite instability in the patient's tumor sample.

To identify any genetic evidence suggesting a possible mismatch repair defect, we performed linkage analysis for MSH2, MLH1 and MSH6 in family 241. MSH2 and MSH6 were excluded as possible candidates. A haplotype of the area surrounding MLH1 appeared to segregate with GI cancers or history of polyps within this family. As a followup study, we performed SSCP analysis of MLH1 and did not identify any mutations in the family.

Family 227

This family is remarkable for the presence of colon cancer in the family and early onset endometrial cancer in the proband. Endometrial carcinomas make up hereditary nonpolyposis colorectal cancer (HNPCC). A germline PTEN mutation was identified in the affected proband. To determine if DNA mismatch repair defect could be identified in this individual, we tested microdissected endometrial carcinoma for the presence of microsatellite instability. There was no evidence of microsatellite instability in her endometrial tumor.

Analysis of PTEN in sporadic thyroid cancers

Affected individuals with Cowden syndrome are at increased risk for non-medullary thyroid cancers. To determine if PTEN contributed to tumorigenesis in sporadic nonmedullary thyroid cancers, we analyzed 28 sporadic thyroid cancers for the presence of mutations in PTEN and loss of heterozygosity at the PTEN locus. Dinucleotide repeat marker AFMa086wg9 located within intron 2 of PTEN was used to determine hemizygous status within the tumor. No loss of heterozygosity events were detected in this collection. We are also sequencing PTEN to identify the presence of any somatic mutations. For this tumor collection, analysis of exons 2-7 have not identified any mutations.

CONCLUSIONS

1. Inherited mutations in PTEN/MMAC predispose to breast cancer. These mutations are always in the context of Cowden's Syndrome, and do not appear in families with breast cancer in the absence of Cowden's symptoms. However, the Cowden's symptoms may be very subtle, and breast cancer may be the first manifestation of PTEN mutation to come to clinical notice.
2. Clinicians should consider testing for mutations in PTEN in patients with very young breast cancer, or breast cancer in combination with other malignancies.
3. Breast cancer patients with germline chromosomal translocations offer excellent opportunity to identify other tumor suppressor genes for breast cancer.
4. Still more genes for inherited predisposition to breast cancer probably exist.

REFERENCES

- Brownstein MH, Mehregan AH, Bikowski JBB, Lupulescu A, Patterson JC. 1979. The dermatopathology of Cowden's syndrome. *Brit J Dermatol* 100:667-673.
- Dietmaier W, Wallinger S, Bocker T, Kullmann F, Fishel R, Ruschoff J. 1997. Diagnostic microsatellite instability: definition and correlation with mismatch repair protein expression. *Cancer Research*. 57:4749-4756.
- Hanssen AMN, Fryns JP. 1995. Cowden syndrome. *J Med Genet* 32:117-119.
- Hanssen AMN, Werquin H, Suys E, Fryns JP. 1993. Cowden syndrome: report of a large family with macrocephaly and increased severity of signs in subsequent generations. *Clin Genet* 44:281-286.
- Lee MK, Lynch ED, King M-C. 1998. SeqHelp: a program to analyze molecular sequences utilizing common computational resources. *Genome Res*: in press.
- Li J, Yen C, Liaw D, Podsypanina K, Bose S, Wang SI, Puc J, Miliareis C, Rodgers L, McCombie R, Bigner SH, Giovanella BC, Ittmann M, Tycko B, Hibshoosh H, Wigler MH, Parsons R. 1997. PTEN, a putative protein tyrosine phosphatase gene mutated in human brain, breast, and prostate cancer. *Science* 275:1943-1946
- Lloyd KM, Dennis M. 1963. Cowden's disease: a possible new symptom complex with multiple system involvement. *Ann Intern Med* 58: 136-142.
- Lynch ED, Ostermeyer EA, Lee MK, Arena JF, Ji HL, Dann J, Swisshelm K, Suchard D, MacLeod PM, Kvinnsland S, Gjertsen BT, Heimdal K, Lubs H, Møller P, King M-C. 1997. Inherited mutations in PTEN associated with breast cancer, Cowden Disease, and juvenile polyposis. *Amer J Human Genet* 61:1254-1260.
- Nelen MR, Padberg GW, Peeters EAJ, Lin AY, van den Helm B, Frants RR, Coulon V, Goldstein AM, van Reen MMM, Easton DF, Eeles RA, Hodgson S, Mulvihill JJ, Murday VA, Tucker MA, Mariman ECM, Starink TM, Ponder BAJ, Ropers HH, Kremer H, Longy M, Eng C. 1996. Localization of the gene for Cowden disease to chromosome 10q22-23. *Nature Genet* 13: 114-116.
- Nelen MR, van Staveren WC, Peeters EA, Hassel MB, Gorlin RJ, Hamm H, Lindboe CF, Fryns JP, Sijmons RH, Woods DG, Mariman EC, Padberg GW, Kremer H (1997) Germline mutations in the PTEN/MMAC1 gene in patients with Cowden disease. *Hum Mol Genet* 6:1383-1387
- Schubert EL, Lee MK, Mefford HC, Argonza RH, Morrow JE, Hull J, Dann JL, King M-C. 1997. BRCA2 in American families with four or more cases of breast or ovarian cancer: Recurrent and novel mutations, variable expression, penetrance, and the possibility of families whose cancer is not attributable to BRCA1 or BRCA2. *Amer J Human Genet* 60: 1031-1040.

Starink TM, van der Veen JPW, Arwert F, de Waal LP, de Lange GG, Gille JJP, Eriksson AW. 1986. The Cowden syndrome: a clinical and genetic study in 21 patients. *Clin Genet* 29: 222-233.

Steck P, Perhouse M, Jasser SA, Yung WK, Lin H, Ligon AH, Langford LA, Baumgard ML, Hattier T, Davis T, Frye C, Rong H, Swedlund B, Teng DHF, Tavtigian SV (1997) Identification of a candidate tumour suppressor gene, *MMAC1* at chromosome 10q23.3 that is mutated in multiple advanced cancers. *Nat Genet* 15:356-362

Szabo CI, King M-C. 1997. Population genetics of *BRCA1* and *BRCA2*. *Amer J Human Genet* 60:1013-1020.

Walton BJ, Morain WD, Baughman RD, Jordan A, Crichlow RW. 1986. Cowden's disease: a further indication for prophylactic mastectomy. *Surgery* 99: 82-86.

Weary PE, Gorlin RJ, Gentry WC Jr, Comer JE, Greer KE. 1972. Multiple hamartoma syndrome (Cowden's disease). *Arch Derm* 106: 682-690.

Williard W, Borgen P, Bol R, Tiwari R, Osborne M. 1992. Cowden's disease: a case report with analyses at the molecular level. *Cancer* 69: 2969-2974.

Inherited Mutations in PTEN That Are Associated with Breast Cancer, Cowden Disease, and Juvenile Polyposis

Eric D. Lynch,^{1,*} Elizabeth A. Ostermeyer,^{1,*} Ming K. Lee,¹ J. Fernando Arena,⁴ HanLee Ji,¹ Jamie Dann,¹ Karen Swisshelm,² David Suchard,³ Patrick M. MacLeod,⁵ Stener Kvinnsland,⁶ Bjorn Tore Gjertsen,^{6,7} Ketil Heimdal,⁶ Herb Lubs,^{4,8} Pål Møller,⁶ and Mary-Claire King¹

Departments of ¹Medicine and Genetics and ²Pathology and ³Harborview Medical Center, University of Washington, Seattle; ⁴Department of Pediatrics and Sylvester Comprehensive Cancer Center, University of Miami, Miami; ⁵Genetics Section, Victoria General Hospital, Victoria, British Columbia; ⁶Unit of Medical Genetics, Division of Oncology, Norwegian Radium Hospital, Oslo; ⁷Sogn and Fjordane County Hospital, Forde, Norway; and ⁸University of Tromsø, Tromsø, Norway

Summary

PTEN, a protein tyrosine phosphatase with homology to tensin, is a tumor-suppressor gene on chromosome 10q23. Somatic mutations in PTEN occur in multiple tumors, most markedly glioblastomas. Germ-line mutations in PTEN are responsible for Cowden disease (CD), a rare autosomal dominant multiple-hamartoma syndrome. PTEN was sequenced from constitutional DNA from 25 families. Germ-line PTEN mutations were detected in all of five families with both breast cancer and CD, in one family with juvenile polyposis syndrome, and in one of four families with breast and thyroid tumors. In this last case, signs of CD were subtle and were diagnosed only in the context of mutation analysis. PTEN mutations were not detected in 13 families at high risk of breast and/or ovarian cancer. No PTEN-coding-sequence polymorphisms were detected in 70 independent chromosomes. Seven PTEN germ-line mutations occurred, five nonsense and two missense mutations, in six of nine PTEN exons. The wild-type PTEN allele was lost from renal, uterine, breast, and thyroid tumors from a single patient. Loss of PTEN expression was an early event, reflected in loss of the wild-type allele in DNA from normal tissue adjacent to the breast and thyroid tumors. In RNA from normal tissues from three families, mutant transcripts appeared unstable. Germ-line PTEN mutations predispose to breast cancer in association with CD, although the signs of CD may be subtle.

Introduction

The protein tyrosine phosphatase and tensin homologue PTEN is a tumor suppressor of glioblastoma, breast cancer and prostatic cancer (Li and Sun 1997; Li et al. 1997; Steck et al. 1997), and malignant melanoma (Guldberg et al. 1997). The gene has at least three names: "PTEN" (phosphatase with *tensin* homology; Genbank accession number U93051), "MMAC1" (mutated in multiple advanced cancers; Genbank accession number U92436), and "TEP1" (TGF β -regulated and epithelial-cell-enriched phosphatase; Genbank accession number U96180). In primary breast carcinomas, both somatic and germ-line PTEN mutations occur, albeit at low frequency (Rhei et al. 1997). Previous observations of loss of heterozygosity (LOH) at chromosome 10q23 in follicular thyroid cancer and endometrial cancers suggested that PTEN might act as a tumor suppressor for these cancers as well (Jones et al. 1994; Zedenius et al. 1995). In patients with Cowden disease (CD; MIM 158350 [Hanssen and Fryns 1995]), germ-line mutations in PTEN have been identified (Liaw et al. 1997; Nelen et al. 1997). Germ-line PTEN mutations are also associated with the closely related Bannayan-Zonana syndrome (Marsh et al. 1997).

In this report, we evaluate families with inherited predisposition to breast cancer and/or CD or related syndromes, for germ-line mutations in PTEN. We identify and characterize germ-line point mutations in PTEN in seven families, describe the cancer and other phenotypes associated with each of these mutations, and demonstrate somatic loss of the wild-type PTEN allele in the associated tumors.

Subjects and Methods

Family Ascertainment

Twenty-five families were included in this analysis. Five families (families 97, 903, 1085, 1130, and 1163;

Received June 18, 1997; accepted for publication October 13, 1997; electronically published December 19, 1997.

Address for correspondence and reprints: Dr. Eric D. Lynch, Division of Medical Genetics, University of Washington, K160 Health Sciences, Box 357720, Seattle, WA 98195-7720. E-mail: genemap@u.washington.edu

*These authors contributed equally to this work.

© 1997 by The American Society of Human Genetics. All rights reserved. 0002-9297/97/6106-0008\$02.00

Table 1

Phenotypes Associated with Inherited Mutations in PTEN

MUTATION(S)	EFFECT	FAMILY	PATIENT (SEX)	PHENOTYPE (AGE [IN YEARS] AT DIAGNOSIS)						
				Skin Lesions	Breast	Endometrium	Thyroid	CNS	Gastrointestinal Tract	
68 T→A	L22X	903	I-2 (F)	+	Ca (46)					
			903	II-1 (F)	+	Ca (24)		Fol Ca (18)	L Hem	
328 C→T	Q109X	1130	I-2 (F)	+	Ca (34)					
565 A→T	R188X	1085	I-2 (F)	+	Bil Ca (31)		Fol Ad	Nf	G, D, C polyps	
			1085	II-1 (F)	+	Ad (29)				
			1085	II-2 (F)	+				C polyps	
697 C→T	R232X	97	II-1 (F)	+	Ca (27)				C polyps	
1003 C→T	R334X	241	I-1 (M)	+				Macro	Sm Int Ca (34)	
			241	II-2 (M)	+			Macro	C, Sm Int polyps	
1003 C→T	R334X	227	II-1 (F)	+	DCIS (41)	Ca (42)	Fol Ad (42)	Macro	R Ca (42)	
1028 T→A and 1039 T→C	V332E and F346L	1163	I-2 (F)		Ca (50)		Ad (49)	Neu (33, 34)		
			1163	II-2 (F)	+	Ad (30)	Ca (48)	Fol Ad (32, 40)		G, C polyps (37, 38)
		1163	II-3 (F)		Atyp H (33)	Ca (42)	Fol Ad (33)		D polyps (31)	
			1163	II-4 (M)					Pin (42)	C polyps
			1163	II-5 (F)		Ca (42)				
			1163	III-1 (F)		Ad (17)		Pap Ca (11)		

NOTE.—Ad = adenoma; Atyp H = atypical hyperplasia; Bil = bilateral; C = colon; Ca = adenocarcinoma; D = duodenal; DCIS = ductal carcinoma in situ; Fol = follicular; G = gastric; Hem = hemangioma; L = liver; Macro = macrocephaly; Neu = malignant neuroma; Nf = neurofibroma; Pap = papillary; Pin = pineal-gland tumor; R = renal cell; and Sm Int = small intestine. A plus sign (+) denotes a chronic condition.

table 1) were ascertained for co-occurrence of breast cancer and CD in the same family. Four other families (including family 227; table 1) were ascertained for co-occurrence of breast and thyroid tumors without definite diagnosis of CD, although the proband of family 227 was subsequently evaluated as having features of the syndrome (table 1). Thirteen families at high risk of breast, ovarian, and/or prostate cancer but with no detected signs of CD were also included. At least one affected member in each of these 13 families had wild-type sequences at BRCA1 and BRCA2; in 2 families, linkage of cancer predisposition to markers flanking PTEN yielded small positive LOD scores (1.3 and 1.2).

Three other families with diagnoses of CD were included. Family 241 (table 1) was diagnosed with both juvenile polyposis syndrome (MIM 174900) and CD. In another CD family, individuals had macrocephaly, skin lesions, and mental retardation but no cancer, in three generations. In a third CD family, affected individuals had thyroid adenomas, intestinal polyps, neurofibromas, lipomas, and colon cancer, at ages 48 and 68 years.

Of the families described above, seven (including 903, 1085, 1130, and 1163) were evaluated clinically at the Norwegian Radium Hospital. Three families (including 227 and 241) were evaluated clinically at the University

of Washington hospitals. The other families were from our series of families at high risk of breast and ovarian cancer. Protocols for human subjects were approved by the institutional review boards at the University of Washington, the Norwegian Radium Hospital, and other collaborating institutions, as appropriate.

Lymphoblast cell lines were prepared (Henle and Henle 1970; Raskind et al. 1984), and DNA was extracted from cell lines and from whole blood, by use of a high-salt-extraction method (Gentra Systems).

Genotyping Families and Tumors

Markers D10S583, D10S215, D10S541, D10S573, and D10S564 were used to determine haplotypes for pedigree analysis and for evaluation of LOH in tumors. Primer sequences for these markers are available on-line from the GenBank (http://www.ncbi.nlm.nih.gov/genbank/query_form.html). Markers were typed by use of PCR conditions and electrophoresis protocols described in the work of Friedman et al. (1994).

Dissection of Tumor Blocks

Paraffin-embedded tissue samples were cut into 5-micron sections for staining with hematoxylin and eosin.

Table 2

Primers That Amplify PTEN cDNA

EXONS	PRIMER		ALIGNMENT TO PUBLISHED cDNA SEQUENCES (nt)		SIZE (nt)
	Forward	Reverse	U93051 (PTEN)	U92436 (MMAC)	
1-5	5'-CCCAGACATGACAGCCATCATC-3'	5'-GTGGTGGGTATGGTCTTCAAAG-3'	1-289	1028-1323	296
4-6	5'-CTGAAAGACATTATGACACCGCC-3'	5'-GTCTCTGGTCCTTACTTCCCATAG-3'	215-486	1249-1520	272
5-7	5'-GGAAAGGGACGAACTGGTGAATG-3'	5'-AGCTGGCAGACCACAACTGAG-3'	379-659	1413-1693	281
6 and 7	5'-CAATGTTCAAGTGGCCGAACCTG-3'	5'-TTTTCTGAGGTTTCCTCTGGTCC-3'	611-866	1645-1900	256
7-9	5'-CAAAGTAGAGTTCTCCACAAACAG-3'	5'-TAGCCTCTGGATTTGACGG-3'	759-1078	1763-2112	320

With the H- and E-stained slide as a guide, normal and tumor cells were microdissected from adjacent 10-micron sections that had also been deparaffinized. Genomic DNA was extracted from the microdissected cells by use of the manufacturer's suggested protocol (Gentra Systems).

Sequencing Genomic DNA, for PTEN Mutations

To analyze patient DNA for mutations in the PTEN gene, nested PCR products corresponding to each of the nine exons were amplified. PCR primers are as described by Steck et al. (1997). PCR products were purified by centrifugation through Sephacryl 300 (Sigma) in 96-well plates (Nalge Nunc International). Purified PCR products were quantified by visual inspection following electrophoresis through 2% agarose gels and ethidium bromide staining. Patient samples were sequenced by use of Energy Transfer Dye Primers (Amersham). The sequencing products were resolved on an ABI377 fluorescent DNA sequencer. Base calling of the trace files was done by use of the ABI sequence-analysis software version 3.0. PTEN-coding sequence and flanking splice junctions were sequenced from 70 independent normal chromosomes.

Transcript Analysis

Isolation of poly(A)⁺ RNA was performed by use of oligo-dT cellulose in a high-salt environment (Sambrook et al. 1989). Patient and control mRNA was reverse transcribed with random hexamers (Amersham) and Superscript Moloney murine leukemia virus RTase (Gibco-BRL), by use of standard procedures. Table 2 indicates the primer pairs used to amplify cDNA, the exons amplified by each pair, and the sizes of amplified products.

PCR was performed for 35 cycles, at 94°C for 15 s, 55°C for 15 s, and 72°C for 1 min, and the products were purified by centrifugation through Sephacryl-300 columns (Sigma). Purified PCR products were cycle sequenced by use of dye-terminator chemistry (Perkin Elmer-ABI). Sequencing products were resolved on 4%

LongRanger acrylamide gels (FMC), with an ABI-377 fluorescent sequencer.

The existence of a pseudogene similar to PTEN complicates mutation analysis of PTEN cDNA. We used cDNA to evaluate stability of mutant PTEN transcripts but not as the template for original mutation detection. Variants detected in cDNA can be inferred to be from the PTEN gene if they are also observed in genomic DNA amplified with PTEN-specific genomic primers.

Results*Mutations in Families*

Mutations in the PTEN-coding sequence were identified in the seven families illustrated in figure 1. All seven mutations involved single-nucleotide substitutions. Six were nonsense mutations leading to immediate stops in exons 1 and 5-8. One variant comprised two missense mutations in exon 9, 1028 T→A (V342I) and 1039 T→C (F346L), on the same parental chromosome. No polymorphisms in the PTEN-coding sequence were detected in any of 70 unrelated chromosomes.

Germ-line mutations in PTEN and their associated phenotypes are indicated in table 1 and figure 1. Multiple invasive cancers occurred in the seven families with germ-line mutations. Among 10 women >30 years of age who had confirmed or probable germ-line mutations, there have been eight breast cancers, three endometrial cancers, one thyroid cancer, one malignant neuroma, and one renal-cell carcinoma. Of the two adult men with germ-line mutations, one died of intestinal cancer at age 35 years, and the other was diagnosed with brain cancer at age 42 years.

Nonsense mutation 697 C→T in individual 9701 is de novo. Parentage in family 97 was verified by multiple markers on chromosome 10 (fig. 1). Both parents have wild-type sequence at bp 697 (fig. 2). It is not clear in which parental chromosome the new mutation occurred. Nonsense mutation R232X was observed previously in

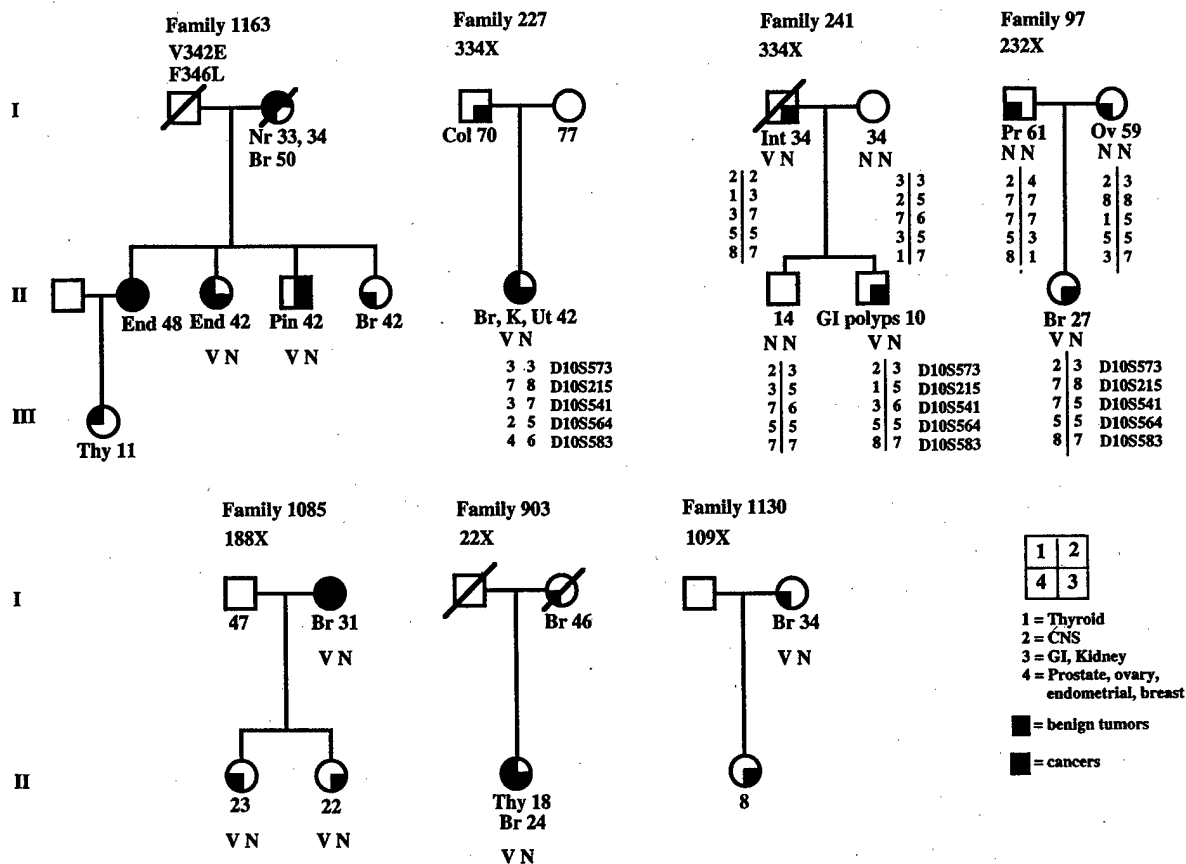

Figure 1 Cancers and noninvasive lesions in families with PTEN germ-line mutations. Symbols are divided into segments on the basis of organ site, with blackened quadrants representing cancers and with gray-shaded quadrants representing noninvasive tumors. PTEN mutations are indicated above each family, and the heterozygous variant (VN) or homozygous normal (NN) genotype for each tested individual is shown below the symbol representing that individual. Haplotypes comprising five markers flanking PTEN are shown for families 227 and 241, to demonstrate the independence of the 1003 C→T mutation. PTEN genotypes and marker haplotypes for family 97 indicate that the PTEN mutation in the daughter is de novo.

a CD patient (Liaw et al. 1997) and occurs in a potential tyrosine phosphate-acceptor motif (Steck et al. 1997).

The paired missense mutations in family 1163 occurred in both affected relatives for whom DNA was available. The wild-type transcript was present, but the mutant transcript was absent, in RNA prepared from whole blood of the affected individuals (fig. 2). Hence the two missense mutations are likely to be on the same chromosome. Mutation 1028 T→A changes the exon 9 splice acceptor from tagGT to tagGA and so may lead to aberrant splicing of this last exon. The instability could be due to the missense mutations or to aberrant splicing.

Nonsense mutation 1003 C→T appeared in both individual 22701 and family 241, as independent mutations. The haplotype constructed from D10S573, D10S215, D10S541, D10S564, and D10S583 in family 241 (fig. 1) shares no alleles with the comparable haplotype in patient 22701. Data from LOH studies of tumor specimens further suggests that allele 7 at D10S541

is on the haplotype with the mutation in patient 22701 (see below).

No germ-line mutations in the PTEN-coding sequence were detected in two families with CD but no early-onset cancers. Nor were germ-line PTEN mutations detected in any of the 13 breast cancer families that have wild-type sequence at BRCA1 and BRCA2. With the screening method that we employed, genomic deletions of an exon or more would not have been detected. However, large deletions do not appear to account for a substantial proportion of germ-line PTEN mutations, although these are common as somatic alterations (Li et al. 1997; Steck et al. 1997).

LOH in Tumors

Biopsy specimens from renal-cell carcinoma, uterine carcinoma, breast ductal carcinoma in situ (DCIS), and thyroid adenoma of patient 22701 were evaluated for

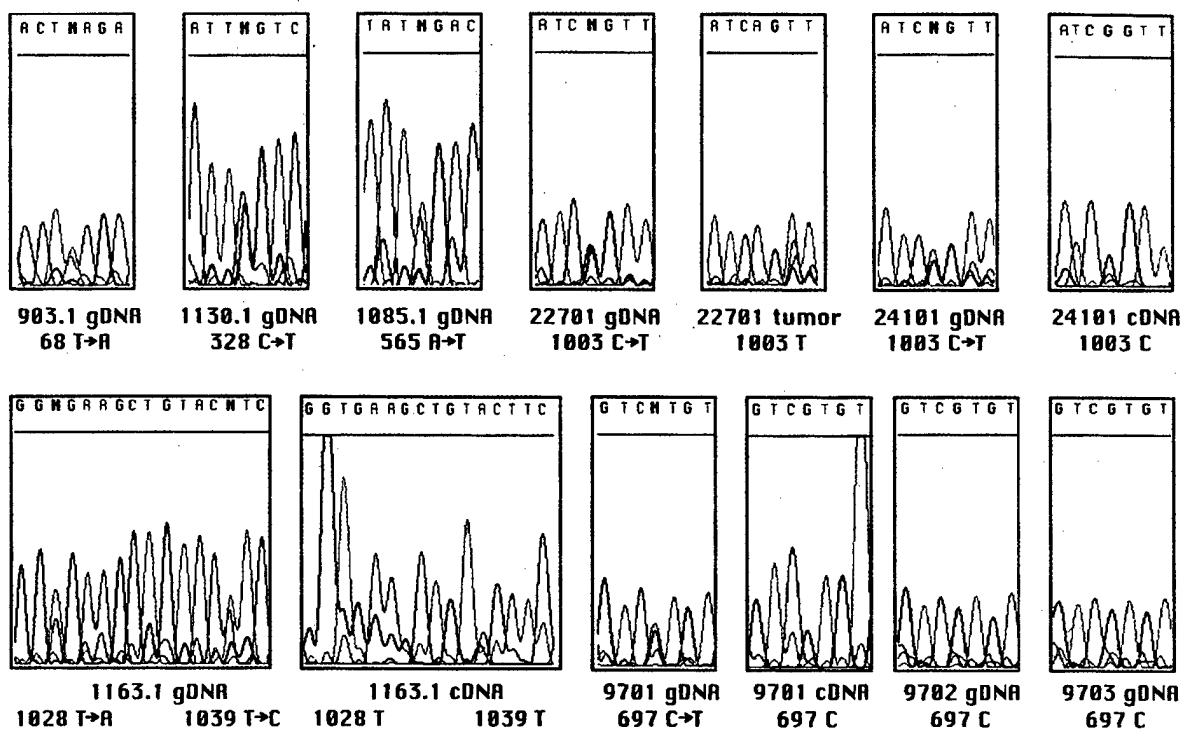

Figure 2 PTEN sequences from genomic DNA (gDNA), tumor DNA, and constitutional cDNA, from families with inherited mutations in this tumor-suppressor gene. Heterozygosity for inherited mutations in genomic DNA is illustrated for probands from seven families. Sequences may be either sense or antisense; mutations are indicated for the sense strand. Sequence "22701-tumor" reflects hemizygosity for the mutant PTEN allele in DNA from the renal-cell carcinoma of patient 22701. Sequences "24101 cDNA," "1163.1 cDNA," and "9701 cDNA" reflect the presence of only the wild-type transcript in normal cells from individuals with mutations, consistent with instability of the mutant transcripts. Sequences of genomic DNA from 9702 and 9703, parents of 9701, are homozygous normal, indicating that the mutation in individual 9701 is de novo.

LOH at PTEN bp 1003 and at markers D10S215, D10S541, and D10S564. All tumors revealed both LOH at the three markers and hemizygosity for the mutant allele at the altered site (fig. 2). Loss of the normal allele and retention of the mutant sequence support the hypothesis that PTEN acts as a tumor suppressor. Normal tissue surrounding the renal-cell carcinoma and the uterine carcinoma were heterozygous at bp 1003, as expected. Interestingly, DNA from apparently normal tissue adjacent to the DCIS and adjacent to the thyroid adenoma was clearly hemizygous, retaining only wild-type sequence.

Loss of Mutant Transcripts from Patient mRNA

For families 97, 241, and 1163, cDNA was prepared from lymphoblast poly(A)⁺ RNA, in order to test the stability of mutant and wild-type transcripts. As shown in figure 2, mutant transcripts were not detected in RNA by dye-terminator sequencing. Loss of mutant transcripts from patients with nonsense mutations is consistent with degradation of these transcripts through a non-

sense-mediated pathway (Decker and Parker 1994; Maquat 1996).

Discussion

The genetics of germ-line mutations in PTEN is consistent with its somatic genetics and biochemistry, all of which indicate that the gene is a tumor suppressor for breast and other cancers (Li and Sun 1997; Li et al. 1997; Liaw et al. 1997; Steck et al. 1997). The PTEN gene has distinctive features at the levels of cells, families, and species. First, the gene is highly conserved. Human and mouse amino acid sequences are >97% identical (Steck et al. 1997). The gene is also highly conserved within humans.

Second, consequences of even minimal mutations may be profound, even at the level of transcription. Nonsense-mediated mRNA degradation leading to transcript instability has been characterized in several species (Leeds et al. 1991; Pulak and Anderson 1993; Cui et al. 1995). Nonsense-mediated mRNA degradation may

play a role in the reduced mRNA expression of disease-related nonsense mutations (Dunn et al. 1989; Lim et al. 1992; Friedman et al. 1994; Menon and Neufeld 1994). The absence of mutant transcripts in cDNA from affected individuals with PTEN germ-line nonsense mutations suggests that the PTEN mutant transcript may be degraded by a nonsense-mediated pathway.

Third, a high fraction of tumors have deleted the gene and some flanking sequence. The phenotypes associated with either somatic or germ-line mutations are highly variable. In the same person, one germ-line mutation and several somatic mutations may lead to tumors in multiple organ systems. The multiple hamartomas in various organs suggest expression in early development and tissue differentiation. A gene critical to early development could well be highly conserved among species.

Lhermitte-Duclos disease is observed in some families with CD and is associated with severe neurological symptoms (Lhermitte and Duclos 1920; Albrecht et al. 1992). None of the patients with detected PTEN mutations in our series were diagnosed with Lhermitte-Duclos disease. Because mutations in these families were found throughout the gene, and because mutations in families with Lhermitte-Duclos disease have been observed in exons 2 and 5-7 and in intron 4 (Liaw et al. 1997; Nelen et al. 1997), it appears unlikely that mutations causing Lhermitte-Duclos disease cluster in any one region of PTEN.

Fourth, a high proportion of observed mutations are new, rather than persisting over several generations or recurring as founder mutations in individuals who are not closely related. PTEN mutations that were observed in more than one family are independent events. These characteristics may reflect mutation and selection interacting in a particularly dramatic way for an important gene. PTEN may be vulnerable to the entire range of types of mutations, but the gene may be so functionally constrained and so ubiquitously expressed that essentially no alterations are benign.

Acknowledgments

We thank Virginia Sybert, Barbara Trask, Rachel Hernandez, and Piri Welch for technical advice and helpful discussion. This study was supported in part by a supplement to NIH grant P30-CA14395 to J.F.A.; by memorial contributions from the Mary Gibford family to K.S.; and by NIH grant RO1-CA27632, Department of Defense grant DAMD 17-94-J-4370, and an American Cancer Society Research Professorship to M.-C.K.

References

- Albrecht S, Haber RM, Goodman JC, Duvic M (1992) Cowden syndrome and Lhermitte-Duclos disease. *Cancer* 70: 869-876
- Cui Y, Hagan KW, Zhang S, Peltz SW (1995) Identification and characterization of genes that are required for the accelerated degradation of mRNAs containing a premature translational termination codon. *Genes Dev* 9:423-436
- Decker CJ, Parker R (1994) Mechanisms of mRNA degradation in eukaryotes. *Trends Biochem Sci* 19:336-340
- Dunn JM, Phillips RA, Zhu X, Becker A, Gallie BL (1989) Mutations in the RB1 gene and their effects on transcription. *Mol Cell Biol* 9:4596-4604
- Friedman LS, Ostermeyer EA, Szabo CI, Dowd P, Lynch ED, Rowell SE, King M-C (1994) Confirmation of BRCA1 by analysis of germline mutations linked to breast and ovarian cancer in ten families. *Nat Genet* 8:399-404
- Guldberg P, Thor Straten P, Birck A, Ahrenkiel V, Kirkin AF, Zeuthen J (1997) Disruption of the MMAC1/PTEN gene by deletion or mutation is a frequent event in malignant melanoma. *Cancer Res* 57:3660-3663
- Hanssen AMN, Frys JP (1995) Cowden syndrome. *J Med Genet* 32:117-119
- Henle W, Henle G (1970) Evidence for a relation of Epstein-Barr virus to Burkitt's lymphoma and nasopharyngeal carcinoma. In: Dutcher RM (ed) *Comparative leukemia research*. Karger, Basel, pp 706-713
- Jones MH, Koi S, Fujimoto I, Hasumi K, Kato K, Nakamura Y (1994) Allelotype of uterine cancer by analysis of RFLP and microsatellite polymorphisms: frequent loss of heterozygosity on chromosome arms 3p, 9q, 10q, and 17p. *Genes Chromosom Cancer* 9:119-123
- Leeds P, Peltz SW, Jacobson A, Culbertson MR (1991) The product of the yeast UPF1 gene is required for rapid turnover of mRNAs containing a premature translational termination codon. *Genes Dev* 5:2303-2314
- Lhermitte J, Duclos P (1920) Sur un ganglioneurome diffus du cortex du cervelet. *Bull Assoc Fr Cancer* 9:99-107
- Li DM, Sun H (1997) TEP1, encoded by a candidate tumor suppressor locus, is a novel protein tyrosine phosphatase regulated by transforming growth factor beta. *Cancer Res* 57:2124-2129
- Li J, Yen C, Liaw D, Podsypanina K, Bose S, Wang SI, Puc J, et al (1997) PTEN, a putative protein tyrosine phosphatase gene mutated in human brain, breast, and prostate cancer. *Science* 275:1943-1946
- Liaw D, Marsh DJ, Li J, Dahia PLM, Wang SI, Zheng Z, Bose S, et al (1997) Germline mutations of the PTEN gene in Cowden disease, an inherited breast and thyroid cancer syndrome. *Nat Genet* 16:64-67
- Lim SK, Sigmund CD, Gross KW, Maquat LE (1992) Nonsense codons in human beta-globin mRNA result in the production of mRNA degradation products. *Mol Cell Biol* 12: 1149-1161
- Maquat LE (1996) Defects in RNA splicing and the consequence of shortened translational reading frames. *Am J Hum Genet* 59:279-286
- Marsh DJ, Dahia PLM, Zheng Z, Liaw D, Parsons R, Gorlin

- RJ, Eng C (1997) Germline mutations in PTEN are present in Bannayan-Zonana syndrome. *Nat Genet* 6:333-334
- Menon KP, Neufeld EF (1994) Evidence for degradation of mRNA encoding alpha-L-iduronidase in Hurler fibroblasts with premature termination alleles. *Cell Mol Biol* 40:999-1005
- Nelen MR, van Staveren WC, Peeters EA, Hassel MB, Gorlin RJ, Hamm H, Lindboe CF, et al (1997) Germline mutations in the PTEN/MMAC1 gene in patients with Cowden disease. *Hum Mol Genet* 6:1383-1387
- Pulak R, Anderson P (1993) mRNA surveillance by the *Caenorhabditis elegans* smg genes. *Genes Dev* 7:1885-1897
- Raskind WH, Tirmali N, Jacobson R, Singer J, Fialkow PJ (1984) Evidence for a multistep pathogenesis of a myelodysplastic syndrome. *Blood* 63:1318-1323
- Rhei E, Kang L, Bogomolny F, Federici MG, Borgen PI, Boyd J (1997) Mutation analysis of the putative tumor suppressor gene PTEN/MMAC1 in primary breast carcinomas. *Cancer Res* 57:3657-3659
- Sambrook J, Fritsch EF, Maniatis T (1989) *Molecular cloning: a laboratory manual*, 2d ed. Academic Press, New York
- Steck P, Perhouse M, Jasser SA, Yung WK, Lin H, Ligon AH, Langford LA, et al (1997) Identification of a candidate tumour suppressor gene, MMAC1 at chromosome 10q23.3 that is mutated in multiple advanced cancers. *Nat Genet* 15:356-362
- Zedenius J, Wallin G, Svensson A, Bovee J, Hoog A, Backdahl, Larsson C (1996) Deletions of the long arm of chromosome 10 in progression of follicular thyroid tumors. *Hum Genet* 3:299-303

BIBLIOGRAPHY

Ostermeyer EA, Lynch ED, Lee MK, Ji HL, Dann J, Swisshelm K, Møller P, King M-C. 1997. Germline mutations in PTEN/MMAC are frequently de novo and predispose to cancers of the breast, intestine, thyroid, uterus, and kidney. **American Society of Human Genetics 47th Annual Meeting**. Abstract 416.

Lynch ED, Ostermeyer EA, Lee MK, Arena JF, Ji HL, Dann J, Swisshelm K, Suchard D, MacLeod PM, Kvinnsland S, Gjertsen BT, Heimdal K, Lubs H, Møller P, King M-C. 1997. Inherited mutations in PTEN associated with breast cancer, Cowden Disease, and juvenile polyposis. **Amer J Human Genet** 61:1254-1260.

PERSONNEL RECEIVING TOTAL OR PARTIAL PAY FROM DAMD17-94-J-4307

Eric D. Lynch, PhD
Senior Fellow

Elizabeth A. Ostermeyer, PhD
Senior Fellow

Ming K. Lee, Ph.D.
Senior Fellow

Jamie Dann, M.S.
Genetic Counselor

Rhoda Argonza
Research Technician

Gigi Chow
Student Lab Assistant