

JPRS: 4729

27 June 1961

HUNGARIAN PNEUMATIC ANALOGUE SYSTEM COMPUTER UNIT

By Imre Szabo

19990806 096

RETURN TO MAIN FILE

Reproduced From
Best Available Copy

Distributed by:

OFFICE OF TECHNICAL SERVICES
U. S. DEPARTMENT OF COMMERCE
WASHINGTON 25, D. C.

U. S. JOINT PUBLICATIONS RESEARCH SERVICE
1636 CONNECTICUT AVE., N.W.
WASHINGTON 25, D. C.

DISTRIBUTION STATEMENT A
Approved for Public Release
Distribution Unlimited

JPRS: 4729

CSO: 1709-S

HUNGARIAN PNEUMATIC ANALOGUE SYSTEM COMPUTER UNIT

[Following is the translation of an article by Imre Szabo in Meres es automatika (Mensuration and Automation) Vol IX, No 2, Budapest, February 1961, pages 57-61.]

The usual composition of the pneumatic control circuits which are used during the solution of the simpler problems concerning regulation and control are described below.

The momentary values of the physical pneumatic characteristics which are to be controlled are sensed by a relay which converts the impulses into corresponding air currents and feeds these air currents into the control system. The control signal is an air pressure in proportion to the sensed physical characteristic. If permanent control is needed, one adjusts the fundamental signal according to the preferred value of the physical characteristic which is to be controlled. This may be done on the control system itself or through the use of a separate apparatus. The controlling device compares the control and the fundamental signals; if there is a difference between the signals, the controlling device alters its output to the activator in order to correct the difference. Accordingly, the generally used pneumatic control circuits are composed of relays and an activator driven by a servo-motor, not considering the external pneumatic accessories used for different purposes (such as registering). The schematic diagram of such a system is shown in Figure 1, which illustrates the water-level control of an open-surface pool.

The liquid level of the pool must be kept constant, despite the irregular water input. This is possible only if the rate of liquid drainage is equal to the rate of liquid replacement. This problem, according to Figure 1, is solved by controlling the drainage as a function of the actual liquid level.

It is easy to see that in order for the controlling action to start, there must be a change in the liquid level, so that in case of disturbance the control signal will differ from the fundamental signal. The magnitude and duration of the connection depend upon the components of the control device, the magnitude of the disturbance, and the characteristics of the pool. Under favourable conditions it is possible to produce only a small degree of correction, or it may be

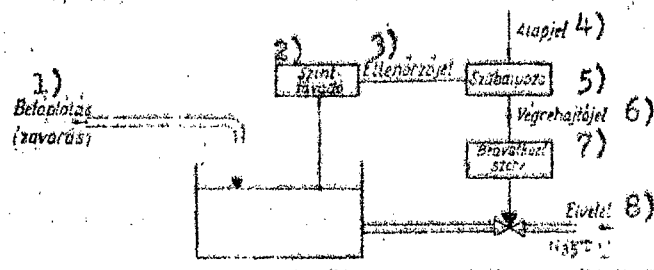

Figure 1.

Legend

- | | |
|-------------------------|----------------------------|
| 1) Input (interference) | 5) Control unit |
| 2) Level relay | 6) Output signal |
| 3) Monitoring signal | 7) Servo-powered activator |
| 4) Fundamental signal | 8) Output |

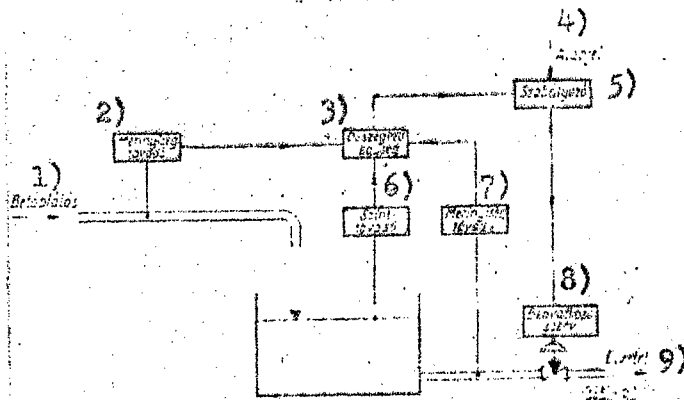

Figure 2

Legend

- | | |
|-----------------------|----------------------------|
| 1) Input | 6) Level relay |
| 2) Rate relay | 7) Rate relay |
| 3) Computer | 8) Servo-powered activator |
| 4) Fundamental signal | 9) Output |
| 5) Control unit | |

impossible to solve the problem with the available equipment.

Obviously, if the rate of liquid drainage equals the rate of liquid replacement the liquid level must remain constant. Therefore, it is advisable to measure the amount replaced and drained and to act accordingly in case of a difference. In spite of an equal drainage and replacement, the constant level may be still arbitrary; therefore, as a third parameter it is necessary to measure the actual liquid level. As shown in Figure 2, this problem is solved with a pneumatic computer unit. According to Figure 2, the computer adds the signals from the relay which measures the amount of liquid replaced and the signals from the relay which measures the actual liquid level; simultaneously, the computer subtracts the signal from the relay which measures the amount of drained liquid. The result is then forwarded to the controlling device, which compares this signal with the fundamental signal and activates the servo-mechanism if needed. It is apparent that because the amount drained equals the amount replaced the computer will forward the level-indicating signal without changing it, and the entire system will work as shown in Figure 1. On the other hand, the result of a change in liquid replacement will show up as a change in the actual liquid level, and the controlling device will act accordingly to correct the difference. Therefore, the controlling action starts even before the disturbance becomes effective; that is, the controlled factor, the liquid level, changes.

With the utilization of the computer, this system offers a fast solution. At this time we should mention that the pneumatic computer can perform not only simple additions and subtractions, but it also makes possible multiplication by a constant figure. Furthermore, it is capable of influencing the signal with a pre-determined dynamic characteristic.

The type MMG pneumatic computer, to be discussed below, is capable of the solution of four simultaneous signals. Naturally, the unit may be used with less than four input signals.

The computer is an important part of pneumatic progressive control systems, since most problems of control can be solved sufficiently only with procedures involving several parameters; that is besides the factors to be controlled, other characteristics of the liquid must be considered.

The Construction of the Computer

The schematic diagram of the computer is shown in Figure 3. As far as operation is concerned, the most important section is the chamber system, consisting of four chambers (a, b, c, d) so that four simultaneous signals may be dealt with. The direction of pressure is negative in chambers "a" and "c" and positive in chambers "b" and "d." By positive in direction, we mean that as the input increases or

decreases, the output of the computer also increases or decreases. In the case of a negative direction the reverse of this is true.

The chamber system is under pressure from a spring that can be adjusted with a hand-crank. The chamber system controls a pneumatic signal-amplifier. This pneumatic signal-amplifier was described in an earlier edition of the MMG. The output of the amplifier is fed into the lowest membrane of the chamber system. The influence of the input pressure in chambers a,b,c, and d is equalized by the output pressure.

The computer unit operates on the compensating-force theory. This theory states that for a given input signal, the output signal can assume only one value.

There are two adjustable chokes built into the apparatus. These are conical needle valves which are useful for the continuous control of the circulating air masses; this is done with a fine adjustment of the cross-section area of the opening. The dynamic characteristics of the computer can be adjusted with these needle valves. Besides these, there is a two-position shut-off valve which also influences the operation of the computer. In its open position the shut-off valve allows the output pressures of the computer to be fed not only under the lowest membrane but also into chamber "a," thus dividing the output by two. This assures a constant mathematical ratio in case only two input signals are used. (In this case, of course, we are not using chamber "a.")

We must also mention that the membranes bordering each chamber are without exception double membranes, even though they are shown as plane membranes on the schematic diagram. This is because they are subjected to pressure from both sides. The four connections on the casing of the cylindrical device are for the input signals. The bottom two serve as valves for the output signal and the air supply. In the fundamental position of the chambers and in the closed position of the adjustable and shut-off valves, the A,B,C, and D signals are fed into their corresponding a,b,c, and d chambers. Since the cylindrical cylinders can rotate around their own axes in their own planes, it is possible to interchange the order of the signals; furthermore, it is possible to achieve a position in which more than one chamber receives the same signal. In this case, of course, the number of workable input signals is less than four. Also, by the rotation of the chambers it is possible to send a signal through the adjustable valve or to allow free air to pass through a chamber. The number of variations that may be produced in this manner allow the computer to perform certain functions; we shall discuss the most important of these. We will not go into all possibilities, but these can be derived from this article.

Figure 3

Legend

- 1) Adjustable choke
- 2) Circulation with atmosphere
- 3) Air supply
- 4) A,B,C,D input signals
- 5) Output signals
- 6) Two-position shutoff valve
- 7) Adjustable choke

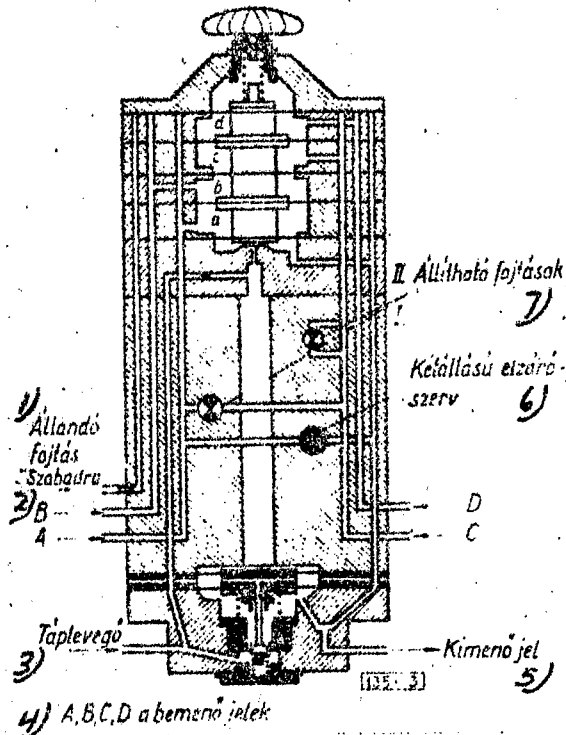

The Operation of the Computer Unit

The computer is capable of processing the four signals, A, B, C, and D, simultaneously. The construction of the chamber system is such that each chamber is isolated alternately with membranes whose surface-area ratio is one to two. If, according to the fundamental setting, we feed signals A, B, C, and D in this order into chambers a, b, c, and d, then the operation will develop according to Figure 4. The equilibrium of the chamber system is expressed in the following formula:

$$B+D-C+B-A-K = 0.$$

The value of the output signal is

$$K = B+D-(A+C)+R.$$

The computer, therefore, subtracts the sum of pressures A and C from the sum of pressures B and D. R is the force exerted by the spring with which we adjust the output-level so that under the circumstances expected during operation a negative signal will not develop. During operation, interference will not develop, even in case of a negative result because the nature of the equipment is such that it cannot produce a negative output.

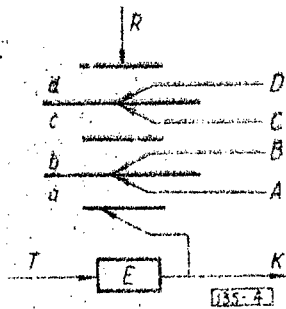

Figure 4.

In such a situation the minimum input signal will always prepare the computer for controlling the action of maximum magnitude and speed. The maximum magnitude and speed are determined by the physical limitations of the equipment. Since the operating range of the pneumatic control system is between .2 - 1.0 atmospheres of pressure, the possibility exists that after the operations have been performed an output signal may result whose pressure is greater than 1.0 atmospheres. In the case of the control system, however, the situation is similar to the one described previously. We do not utilize the computer as a single unit where its limitations would be disadvantageous.

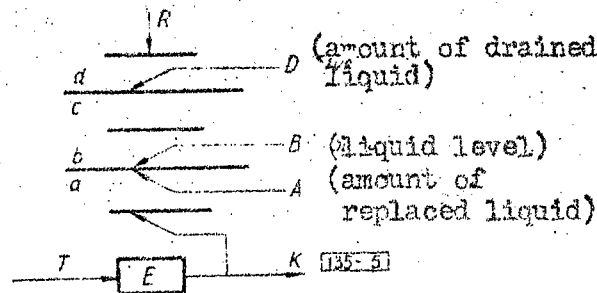

Figure 5

We must also mention that the letters used in the above illustrations represent forces, and that the A, B, C, and D forces result from the input pressures and act upon the surfaces of the chambers in use. The chamber surfaces are equal; as a result, the forces are proportional to the pressures. This is why we can use the letter symbols to represent pressures. If less than four input signals are used, certain connections on the analyzer will remain free. In place of the letters corresponding to them we substitute a zero; thus, the equation remains valid.

The connection diagram of the computer in the control system shown in Figure 2 is shown in Figure 5. In this case one connection (C) is not used, and according to the formula the value of the output signal can be determined in the following manner:

$$K = B + D - A + R.$$

Since R, which is adjusted by a spring, is a constant, it is obvious that the output of the computer depends upon the actual liquid level when the rate of liquid replacement and drainage is equal ($A = D$).

The function of the two-position shut-off valve shown in Figure 3 is illustrated in Figure 6. The output of the computer is fed into chamber "a" in addition to the normal feedback. This is accomplished through the opening of the two-position shut-off valve. (Naturally, in this case the A connection is sealed off from the outside.)

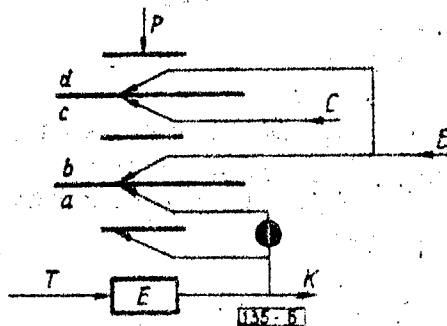

Figure 6

This example also illustrates the possibility of feeding one signal into two chambers simultaneously by rotating the chambers. In this case we shall feed signal B into chambers b and d. The equation is the following:

$$R + B - C + B - K - K = 0;$$

$$K = \frac{2B - C + R}{2}.$$

It is obvious that the feeding of the output signal into chamber "a" resulted in a division by two, while the effect of signal B was doubled. When such connections are used we place much greater emphasis on the B parameter than on that of C.

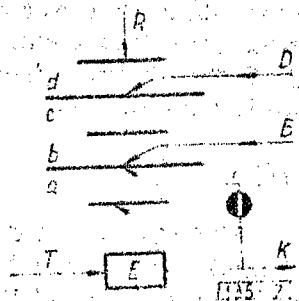

Figure 7

Figure 7 illustrates the method of obtaining the algebraic mean of the two signals according to the following relationship:

$$K = \frac{B+D}{2} + \frac{R}{2}$$

Figure 8 shows a situation in which we wish to place less emphasis on a signal. The A and C signals are fed into chamber "d" through adjustable choke no II. Chamber "d" is in circulation with the atmosphere through a constant choke.

Circulation
with atmas
phere

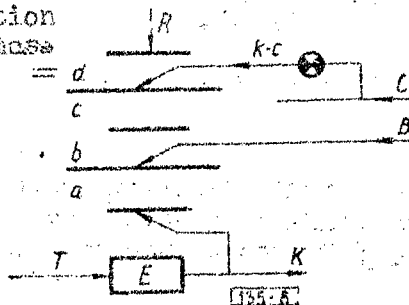

Figure 8

The A and D input connections are sealed from the outside. Thus, we have created a pneumatic member (RCR). The constant value of the pressure developed in the intermediate storage chamber (d) will be (kA) , where $(0 < k < 1)$. The value of (k) can be adjusted with choke no II. The value of the output signal is:

$$K = kC + B + R.$$

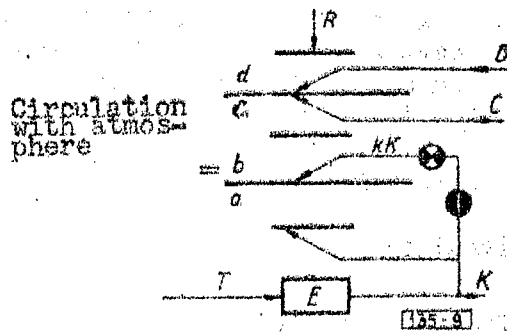

Figure 9

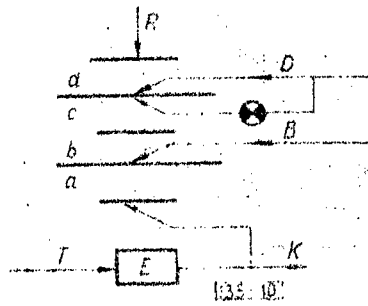

Figure 10

When proper coupling is used, the amplification factor of the computer can be changed with adjustable choke no I. This connection diagram is shown in Figure 9. As an example, the computer must process negative (C) and positive (D) input signals. The input connection is sealed from the outside. The output signal is fed through choke no I. into chamber "b," which is in circulation with the atmosphere through the constant chokes.

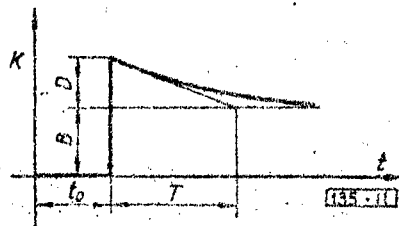

Figure 11

The (RCR) member thus created is stored in chamber "b;" the pressure that is developed here will have a value of $(k-K)$, where $(0 < k < 1)$. The value of (k) is determined by the adjustable choke. The balancing equation of the chamber system is:

$$R+D-C+kK-K=0.$$

The value of the output signal is:

$$K = \frac{1}{(1-k)} (D-C+R).$$

Therefore, the amplification factor becomes:

$$\frac{1}{1-k}$$

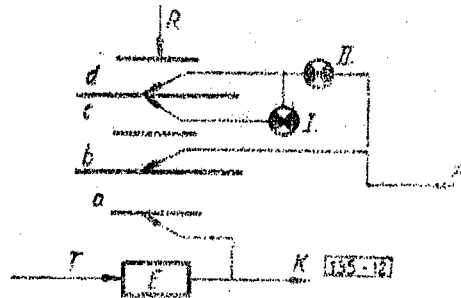

Figure 12

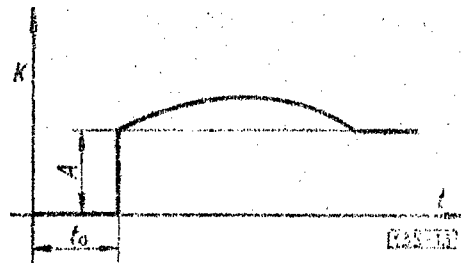

Figure 13

Since the value of (k) can be adjusted between $(0-1)$, theoretically the amplification factor can be adjusted between $(1-∞)$; in practice, we can acquire an amplification factor of $(35-40)$. This satisfies the industrial needs in all respects.

The variations so far discussed were the statistical functions of the computer. As we mentioned before, the computer is also capable of the dynamic analyzation of the individual signals.

In the case of the set-up shown in Figure 10, the D signal is fed into chambers d and c in proportion, but into chamber "c" we feed signal D through an adjustable choke. Thus, in the first moment signal D, enters only chamber "d." The equation is:

$$K=D+B+R; t=t_0.$$

Starting from ($t=t_0$) time interval, the value of the output signal begins to decrease since the D signal begins to fill up chamber "c" through the adjustable choke. After the filling process has taken place, the pressure in chamber "c" will build up to equal the pressure in chamber "d." The time which is required to reach the stable condition depends upon the setting of the adjustable choke. The equation of this function in the stable condition is:

$$K=B+R.$$

By comparing the two equations it is easy to see that the computer considers the D signal at the beginning of its operation only; later on, it disregards it. Naturally, this situation exists whenever the D signal changes even to a small degree. Figure 11 shows the functions of this changing process; this refers to the sudden engagement of signals B and D.

The occasional occurrence of interference signals in such a computer should be noticed. The influence of these interference signals is the greatest during periods of no change in the control signals.

Figure 12 illustrates a system in which the effect of the input signals is intensified for a certain period of time, but when the stable condition is reached the output signal is set back to its original value. Two adjustable chokes are used for this purpose. Figure 13 illustrates the transition of this process.

The capabilities of this computer have still not been exhausted. The cases mentioned above serve only as examples. The method of connection should be chosen with consideration for the properties of the section which is to be controlled. With the utilization of the computer the usefulness of pneumatic control systems is greatly expanded; furthermore, it becomes possible to cope with problems which could not be solved with simpler control systems. The photograph of the apparatus is shown in Figure 14. It is finished in gray hammertone.

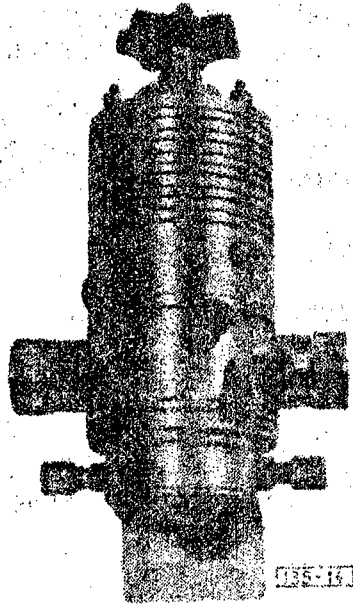

Figure 14

The properties of the computer are:

Number of input signals.....	4
The range of input signals.....	0.2 - 1.0 atmospheres
The range of output signals.....	0.2 - 1.0 atmospheres
The pressure of air feed.....	1.2 atmospheres
Accuracy.....	$\pm 1.0\%$
Type number.....	137-230.

The pictorial diagram is shown in Figure 15.

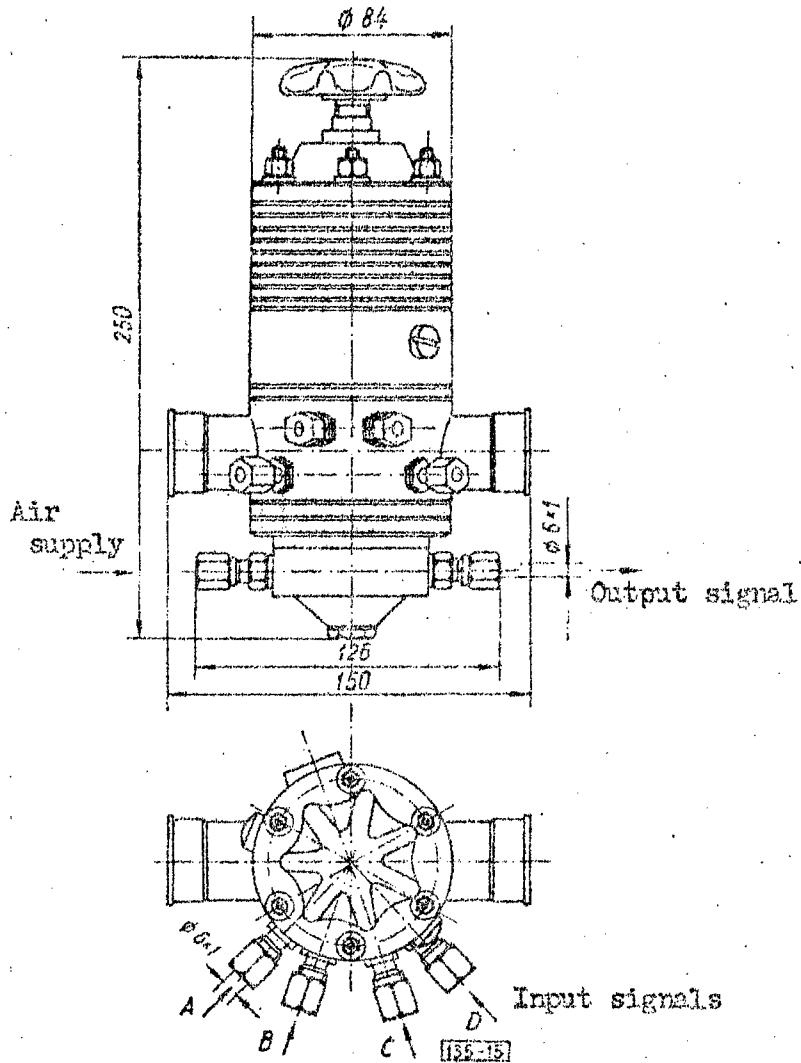

Figure 15

10,419

-END-