

ARMY RESEARCH LABORATORY



Travel Software Requirements Analysis: A C-BASS Component

by Barbara F. Gravels and
Vickie L. Smith

ARL-MR-453

August 1999

19990813 060

Approved for public release; distribution is unlimited.

The findings in this report are not to be construed as an official Department of the Army position unless so designated by other authorized documents.

Citation of manufacturer's or trade names does not constitute an official endorsement or approval of the use thereof.

Destroy this report when it is no longer needed. Do not return it to the originator.

Army Research Laboratory

Aberdeen Proving Ground, MD 21005-5066

ARL-MR-453

August 1999

Travel Software Requirements Analysis: A C-BASS Component

Barbara F. Gravels and Vickie L. Smith
Corporate Information and Computing Directorate, ARL

Approved for public release; distribution is unlimited.

Abstract

This document presents the software requirements analysis for Travel, Version 1.0, a component of the Corporate Business Application Software System (C-BASS) that automates travel requests for the U.S. Army Research Laboratory (ARL). The document follows the process of structured analysis, or step-wise refinement of requirements, as applied to the development of a prototype for the full version of Travel. The "environmental model" includes a high-level system description, followed by a context diagram and a list of events to which the system must respond. The "behavioral model" includes a data flow diagram (DFD) for each of the four Travel 1.0 subsystems. From this representation, the basic functional specifications are derived and represented in structured English (or program design language). The final segment of the document includes a data dictionary that defines all data and control items.

Table of Contents

	<u>Page</u>
List of Figures	v
List of Tables	v
1. Introduction	1
1.1 Travel Version 1.0.....	1
1.2 Development Plan and Project Schedule	1
1.3 Contents of This Report	1
2. Structured Analysis Overview	3
3. System Overview	4
3.1 Required Functionality	4
3.2 Context Diagram	5
3.3 Event List	6
4. System Requirements	6
5. Functional Specifications	11
5.1 Travel Subsystems.....	11
5.2 Subsystems Data Flow Diagrams	12
5.3 Processing Narration	15
6. Data Dictionary	23
7. References	45
Distribution List	47
Report Documentation Page	49

INTENTIONALLY LEFT BLANK.

List of Figures

<u>Figure</u>	<u>Page</u>
1. Travel Process Diagram.	2
2. Scope of System Activities.....	2
3. Context Diagram for Travel.	5
4. Major Subsystems of Travel.....	12
5. Prepare Travel Request Subsystem.	13
6. Approve Funds Subsystem.....	14
7. Edit/Cancel Travel Request.....	15
8. Inquiries Process.....	15

List of Tables

<u>Table</u>	<u>Page</u>
1. High-Level Requirements for Travel Version 1.0.....	4

INTENTIONALLY LEFT BLANK.

1. Introduction

Travel Version 1.0 is a component of the Corporate Business Application Software System (C-BASS) family of applications, an integrated set of Lotus Notes and Web-based software to support U. S. Army Research Laboratory (ARL) electronic workflow and task automation. The motivating force behind the C-BASS project has been ARL downsizing and findings elaborated on in the Business Process Reengineering (BPR) exercises in organizational change beginning in 1996. Travel Version 1.0 is the second software deliverable of the C-BASS. BuyIt (an automation of the small purchase process) was the first.

1.1 Travel Version 1.0. The purpose of Travel Version 1.0 (referred to hereafter as Travel 1.0) is to model a secure client/server system that provides for the processing of travel requests for ARL personnel. This proof-of-principle prototype will alleviate some of the risks involved in implementing new technologies used to build the ARL Intranet.

The essential, top-level requirements for Travel 1.0 are described in the ARL BPR "To-Be Model: ARL Travel Orders" [1]. This document refines the requirements set forth in that antecedent report. Figure 1 shows the flow of the travel process based on the BPR "To-Be Model: ARL Travel Orders."

1.2 Development Plan and Project Schedule. Development of a full production travel automated system will proceed in phases, using an incremental, evolutionary approach. As Figure 2 indicates, Travel 1.0 is a scaled-down rendition of the overall travel process, which includes preparing the travel request, obtaining approvals, and generating an electronic travel packet including a hard copy of DD1610 and a Travel Information Sheet.

1.3 Contents of This Report. This document presents the results of a structured system analysis used to derive the software requirements for Travel 1.0, starting with the baseline requirements given in the BPR "To-Be Model: ARL Travel Orders" [1]. The body of the report contains five sections:

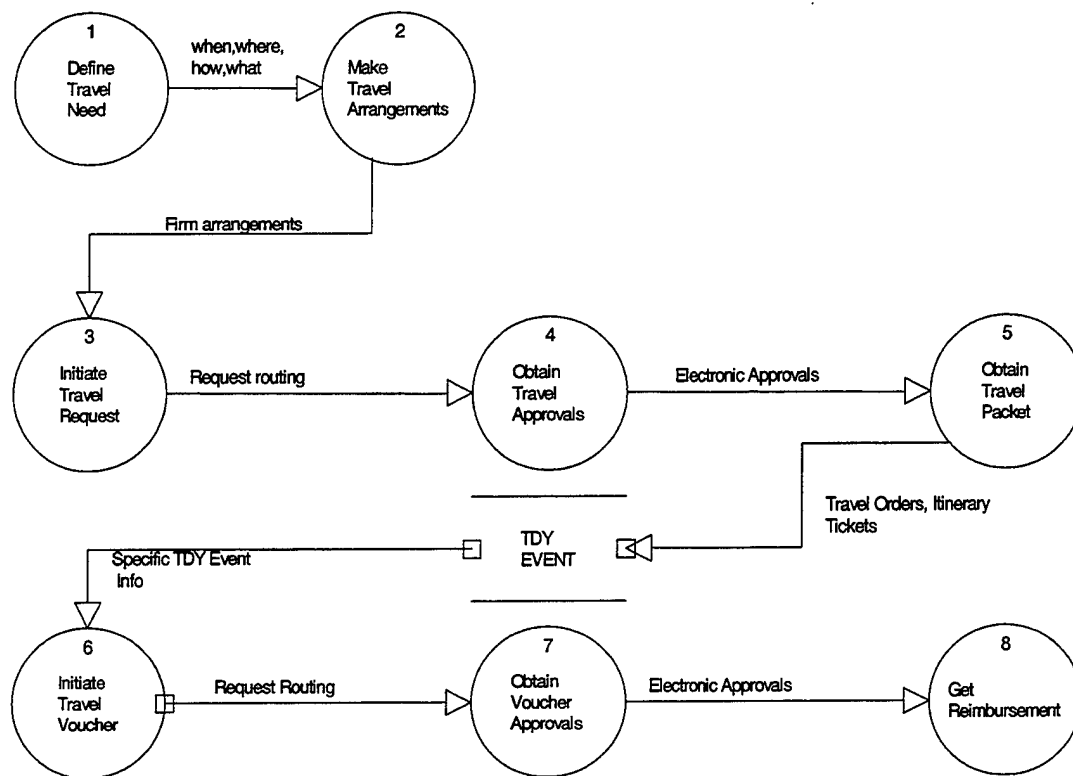

Figure 1. Travel Process Diagram.

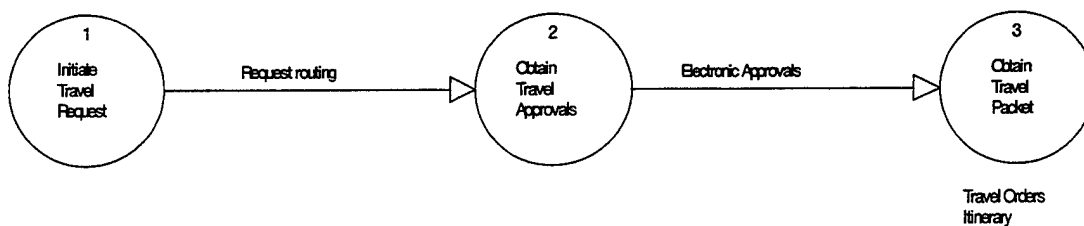

Figure 2. Scope of System Activities.

- “Structured Analysis Overview” - briefly explains the methodology used to extract the software functional specifications.
- “System Overview” - describes the basic Travel 1.0 concept and outlines the high-level requirements.
- “System Requirements” - breaks the general requirements into lower-level, derived requirements and describes each in detail.
- “Functional Specifications” - discusses the products of the structured analysis (i.e., the data flow diagrams (DFDs) and structured English narrative), for each subsystem of Travel 1.0.
- “Data Dictionary” - lists each of the Travel 1.0 data elements, giving the full description and type for the data model.

2. Structured Analysis Overview

The purpose of a structured analysis is to develop detailed specifications from high-level requirements. Through a series of step-wise refinements, primary system functions are broken down into progressively more detailed levels of processes, and the data flows between these processes are defined. Three modeling tools facilitate this decomposition: (1) DFDs, (2) structured English process narratives (represented in pseudo-code or program design language [PDL]), and (3) a data dictionary defining each object (data or control item).

The results of this analytical approach are systematic elaborations of product requirements, typically expressed as two separate types of composite models:

- An environmental model that defines the system’s interfaces to the outside world (see section 3, “System Overview”).
- A behavioral model that defines the internal behavior the system must exhibit in order to deal with the environment (see section 4, “System Requirements,” and section 5, “Functional Specifications”).

3. System Overview

The environmental model typically consists of three components: (1) a concise statement of the system's purpose and required functionality, (2) a context diagram, and (3) an events list. The context diagram is the highest level DFD. It shows the system as a single process, including users' interaction and communication with external systems, as well as data flow input and output. The events list is an index of outside stimuli the system must respond to in order to accomplish the purpose of the system.

3.1 Required Functionality. The overall concept of Travel 1.0 is to provide a secure, automated means for the preparation, routing, approval, and tracking of travel requests. Table 1 lists the high-level requirements for Travel 1.0 and gives a general description of what the requirements involve.

Table 1. High-Level Requirements for Travel Version 1.0

Requirement	Description
Security	Provide security measures to prevent unauthorized access to the system and its data and keep authorized users from performing tasks not allowed in their roles
Travel Request Preparation	Provide a means for the requesters and functional users to input/edit relevant information pertaining to a travel request
Automated Request Routing	Automate the process of travel requests to the various functional areas
Electronic Approval	Provide a means for designated officials and functional users to electronically approve, reject, or cancel a travel request
Request Tracking	Allow users to track the status of active travel requests currently in the system and provide printing capability
Legacy System Interface	Implement automated interfaces to SOMARDS and ORACLE systems ^a

^a ORACLE systems are software solutions produced by Oracle Corps. Standard Operating and Maintenance Army Research Development System (SOMARDS) is a Defense Department legacy system.

3.2 Context Diagram. Figure 3 shows the context diagram for Travel 1.0. Each outlying square in the diagram represents an external entity (users, functional areas, and legacy systems) with which Travel 1.0 communicates. The arrows indicate the data that flow into and out of Travel 1.0.

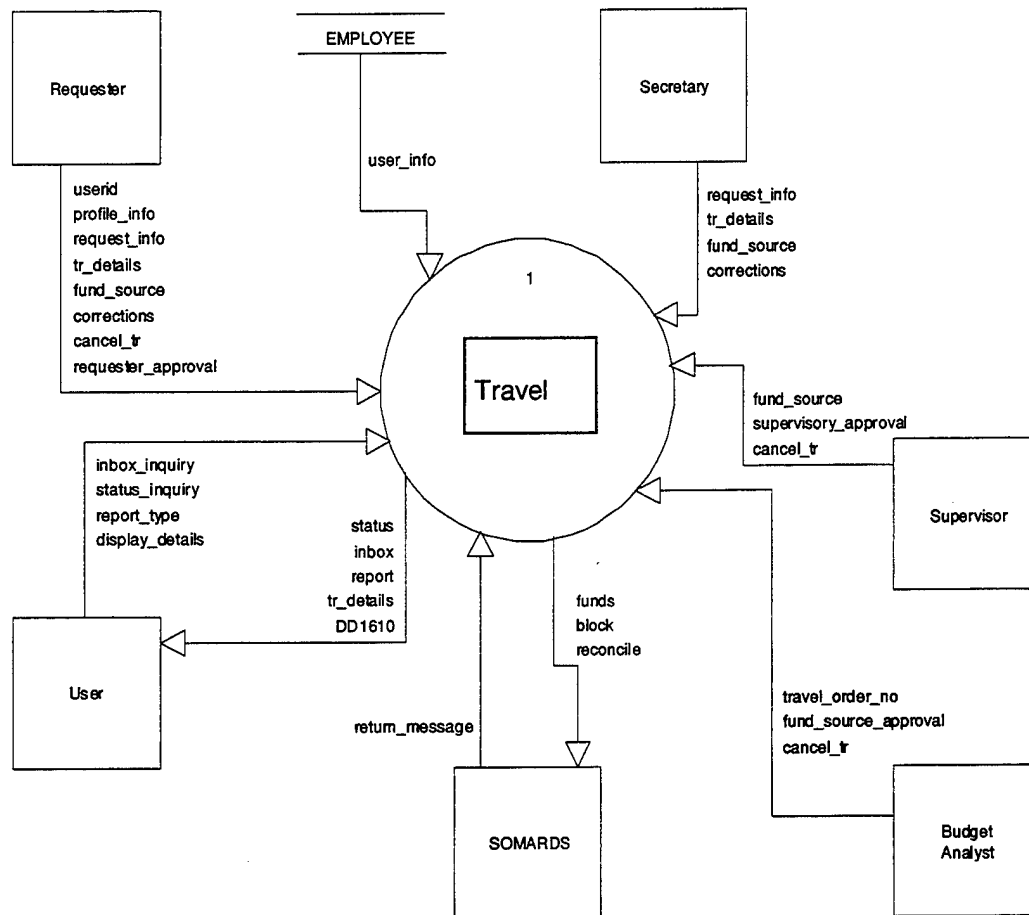

Figure 3. Context Diagram for Travel.

A few elements on Figure 3 need additional explanation. First, the external entity “User” represents all users of the system, and the data flows associated with the box indicate display of basic information. Second, all of the other external entities (“Requester,” “Secretary,” “Supervisor”), and their corresponding data flows show the specific information that is passed to

Travel 1.0 by the user or by the system. Lastly, the data store EMPLOYEE contains user information, such as name, phone number, address, office symbol, and the like.

3.3 Event List. The following list contains the events to which the system must respond:

- Requester defines travel needs and itinerary.
- Requester prepares travel request.
- Fund source is completed at the office level.
- Requester, secretary, supervisor, or budget analyst cancels or rejects travel request.
- Budget analyst approves fund source.
- Travel 1.0 generates a travel order number.
- SOMARDS certifies and commits funds.
- Ability to view, review, and track forms.
- Routing.
- Reporting.
- Requester obtains a Travel Packet (DD1610, Travel Information Sheet) when form is completed.
- Email notification.

4. System Requirements

Antecedent studies and legacy systems, as well as user-centered task analyses for business practices, contribute to Travel 1.0's concept-level requirements. For example, the "Report Specifications" [2] and the "To-Be Model: ARL Travel Orders" [1] documents, produced during the BPR development effort, contributed characterizations of core business processes and preliminary descriptions of subsystems to accomplish defined tasks. However, for some areas, these documents lack detail; hence, necessary elements had to be derived. Additionally, requirements have been adjusted to accommodate the constrained scope of a prototype implementation. The "Travel Software Development Plan" [3] more fully addresses the boundaries of the prototype and the impact of the legacy systems on Travel 1.0's design.

E1 Security

E11 Prevent unauthorized access

- Description — Prevent unauthorized access to the system and its data.
- Source — Derived, due to the nature of the system.
- Interfaces to major functions and external entities:
 - User

E12 Enforce role restrictions

- Description — Prevent users from performing tasks or accessing/editing data that are out of the scope of their role.
- Source — BPR “To-Be Model” document, Automation Requirements section, requirement.
- Interfaces to major functions and external entities:
 - User
 - Approvals
 - Edits
 - Employee address book (for roles)

E2 Travel request preparation

E21 Create traveler profile

- Description — Allow the requester to create a traveler profile with preliminary user information filled in.
- Source — Derived from the need for a more automated system.
- Interfaces to major functions and external entities:
 - User
 - Security
 - Employee address book (for user info.)

E22 Select travel requirements

- Description — Import traveler profile data and provide a means for the user to enter proceed date, itinerary, purpose of travel, transportation mode, per diem, and other estimated costs, other specific info., and fund source.
- Source — BPR “To-Be Model” document, Automation Requirements section, requirement A1.
- Interfaces to major functions and external entities:
 - User
 - Traveler profile
 - Security

E23 Select additional Information

- Description — Provide means for the user to enter lodging info., rental car info., tdy site info., and airline info.
- Source — User requested.
- Interfaces to major functions and external entities:
 - User
 - Security

E24 Complete travel request

- Description — Provide a means for the requester and/or supervisor to complete the fund source.
- Source — BPR “To-Be Model” document, Automation Requirements section, requirement A2.
- Interfaces to major functions and external entities:
 - User
 - Security

E25 Edit travel request

- Description — Provide a means for users to edit certain request details as needed.
- Source — Derived, due to the need for making corrections to travel request.
- Interfaces to major functions and external entities:
 - User
 - Security

E26 Cancel travel request

- Description — Provide a means for users to cancel a travel request as needed.
- Source — BPR “To-Be Model” document, Automation Requirements section, requirement A2.
- Interfaces to major functions and external entities:
 - User
 - Security

E3 Routing

- Description — Automate the process of routing travel requests to the various functional areas and approving officials.
- Source — BPR “To-Be Model” document, Automation Requirements section, requirement A1.
- Interfaces to major functions and external entities:
 - Security
 - Employee address book (for default routing)

E4 Electronic Approval

- Description — Provide a means for approving officials and functional users to approve, reject, or cancel a travel request.

- Source — BPR “To-Be Model” document, Automation Requirements section, requirement A2.
- Interfaces to major functions and external entities:
 - User
 - Security

E5 Legacy system interfaces

- Description — Provide an electronic interface to the legacy financial system (SOMARDS) that automates the certification and commitment of funds.
- Source —To-Be Model section, process model diagram A3, process A33.

E6 Inquiries

E62 Status Inquiries

- Description — Allow users to track the status of active travel requests currently in the system.
- Source — User requested.
- Interfaces to major functions and external entities:
 - User

E63 Reports

- Description — Allow users to generate reports and print DD1610.

E64 Print Travel Details

- Description — Ability to print travel details.

E7 Navigation

- Description — Provide users with a means for navigating to the various functional areas within the system.
- Source — Derived from the requirements listed previously.
- Interfaces to major functions and external entities:
 - User

5. Functional Specifications

The behavioral model expands the analytical results from the environmental model to define more fully how the system performs its prescribed tasks. Typical representations in this model are (1) concise data flow charts showing how information is transformed as it moves through the system and subsystems, (2) a set of structured English statements forming a processing narration based on data types, control structures, and transformations, and (3) a data dictionary defining each data and control item.

5.1 Travel Subsystems. The seven functionalities listed in the previous section identify the major required functionality of Travel 1.0: (1) security, (2) travel request preparation, (3) routing, (4) electronic approval, (5) legacy system interfaces, (6) inquiries, (7) navigation. For the purpose of deriving more complete software specifications in this design exercise, these preliminary categories are consolidated into four subsystems: (1) Prepare Travel Request, (2) Approve Funds Process, (3) Inquiries, and (4) Edit/Cancel Travel Request.

Figure 4 shows the major functional subsystems of Travel 1.0, as represented by a DFD. Each of the four bubbles in the diagram represents a major subsystem or process, with the arrows showing the data flowing into and out of the processes.

The data store ACTIVE, located in the center of the diagram, holds all the active travel requests, while waiting for the various users to perform their functions on them. The CANCELED data stores contain travel requests that have been canceled. The small squares along the outer edges of this DFD are interfaces to the outside world.

No process bubble for security appears at this level because the application development environment (i.e., Lotus Notes) handles user authorization and system security. Additionally, enforcement of role restrictions is handled within each subsystem, as detailed in section 5.2.

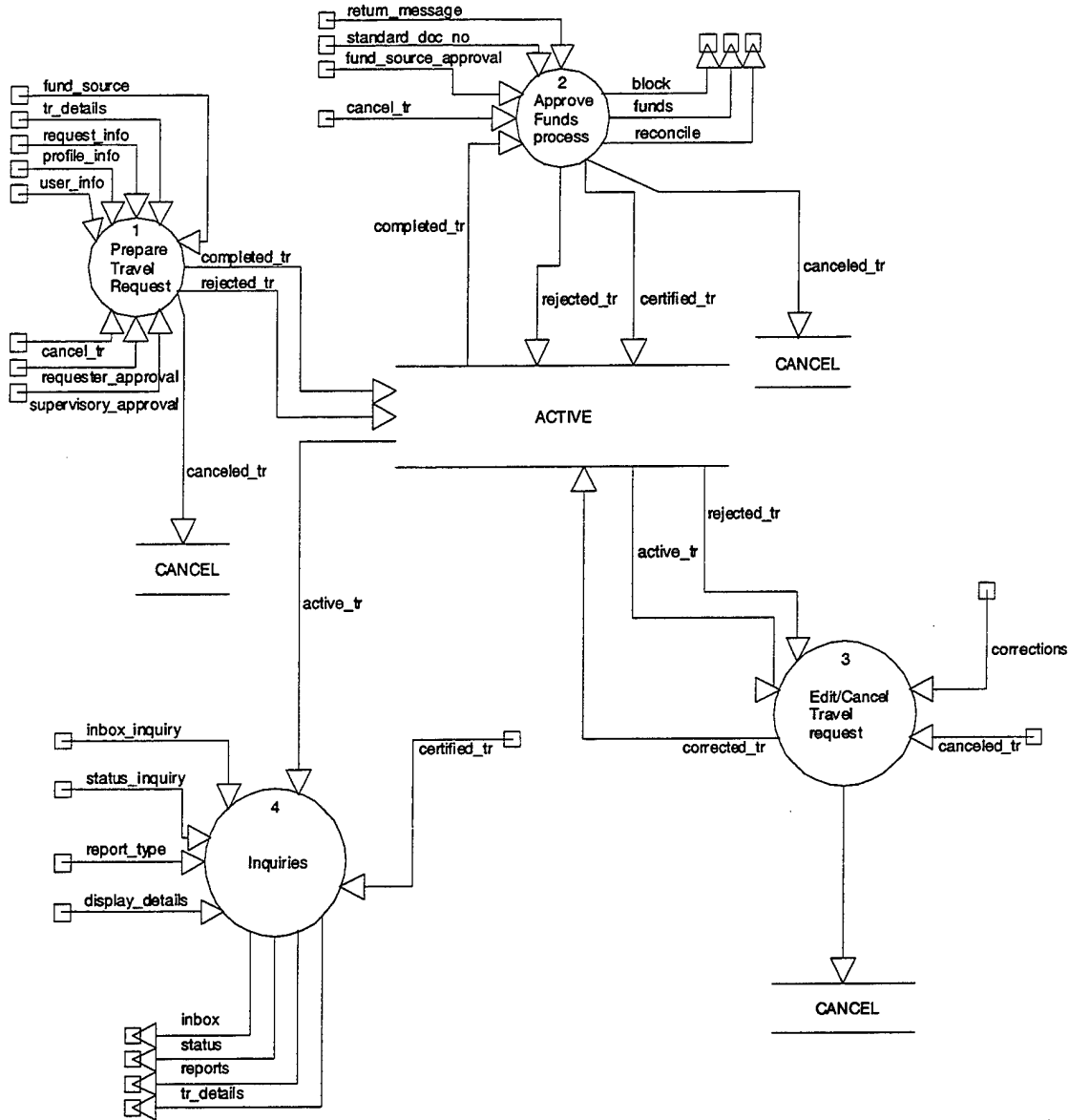

Figure 4. Major Subsystems of Travel.

5.2 Subsystems Data Flow Diagrams. System objects and operations can be coherently represented as DFDs. A DFD can be used to capture system concepts and components at any level of abstraction. Each of the following four DFDs (Figures 5–8) provides more detail for the information flow and the functionality of each of the identified Travel 1.0 subsystems.

Figure 5 shows the DFD for the Prepare Travel Request subsystem. The major inputs to this process (and its basic functions) are the requester information (derived from the user-supplied userid and the EMPLOYEE data store), profile information, travel request information, and travel details. The fund source completes the information for the request and the requester, and supervisory approval puts the request into the travel cycle.

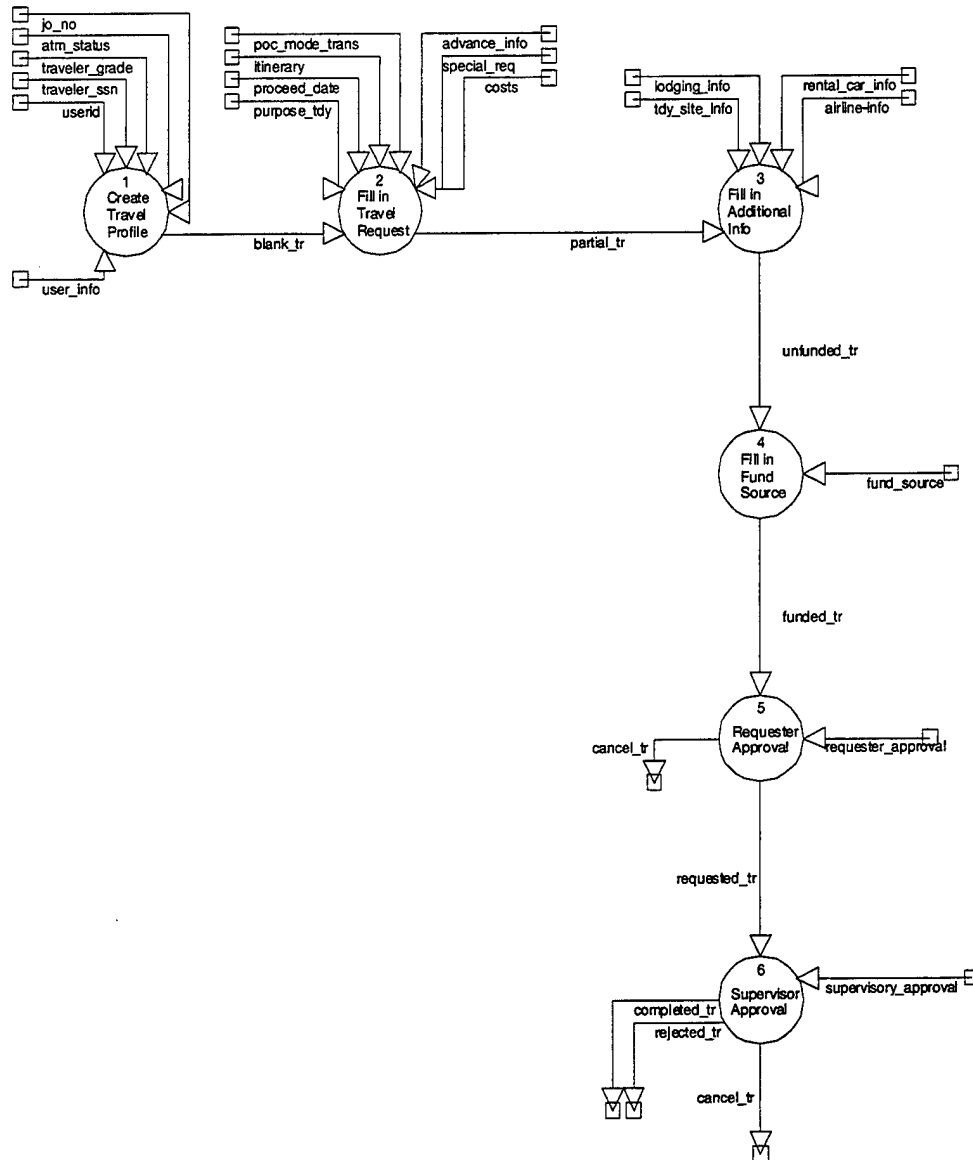

Figure 5. Prepare Travel Request Subsystem.

Figure 6 shows the DFD for the Approve Funds subsystem. This subsystem, besides having interfaces to users for approvals, also interfaces with Budget for approvals and connects to the SOMARDS legacy system. The Build Block process is executed at the start of the day and creates the transaction block that will be used by Travel 1.0 for the remainder of the day. As travel requests are created during the course of the day, the Certify Funds process polls SOMARDS and grabs the returning message. Depending on the results, the request is either certified or rejected (with explanation). At the end of the day, the Reconciled process is executed to balance the transaction block.

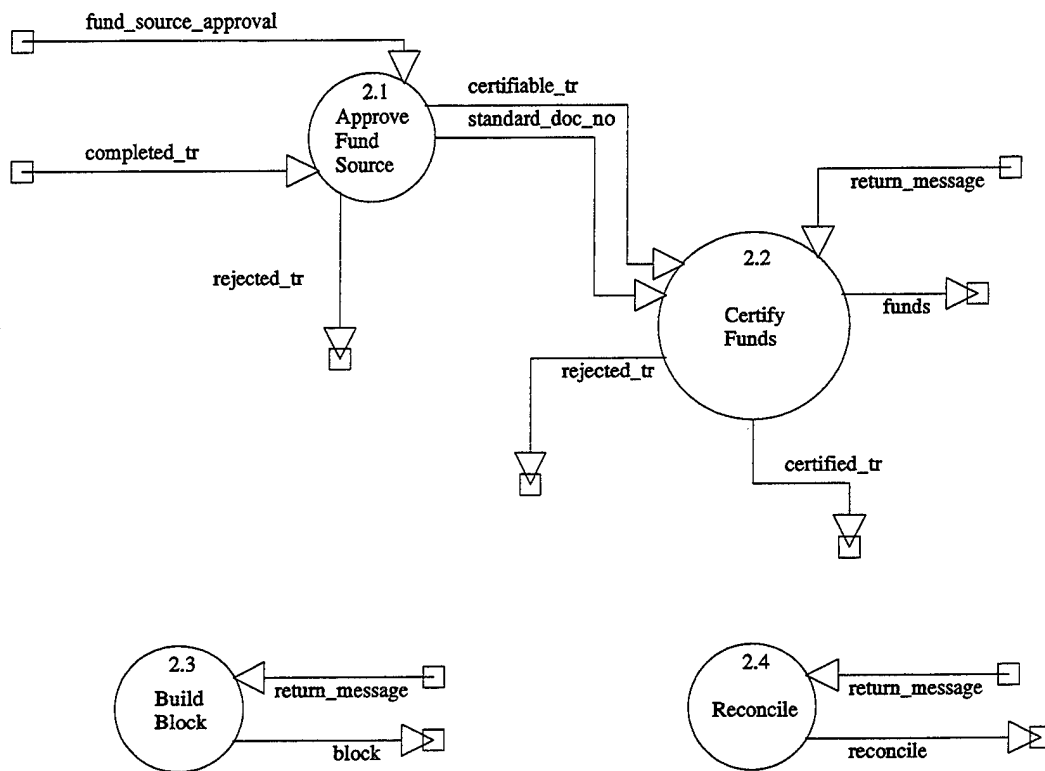

Figure 6. Approve Funds Subsystem.

Figure 7 diagrams the Edit/Cancel Travel Request process. The rejected travel request is displayed to the requester for corrections. Depending on where the rejection came from and how far along the approval process the request has traveled, the requester will only be allowed to edit certain fields within the form.

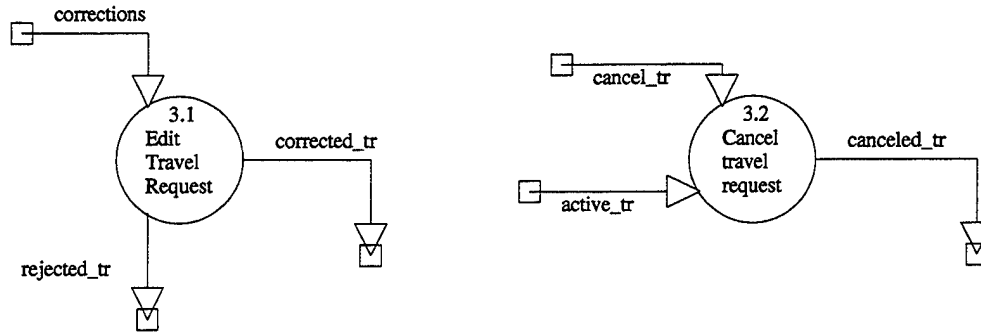

Figure 7. Edit/Cancel Travel Request.

The INQUIRIES process is diagrammed in Figure 8. The processes shown in this figure are used to display to the user pending actions (inbox), status of requests, reports, and travel request details. The user also has the capability to print the DD1610 and the Travel Information Sheet at this point.

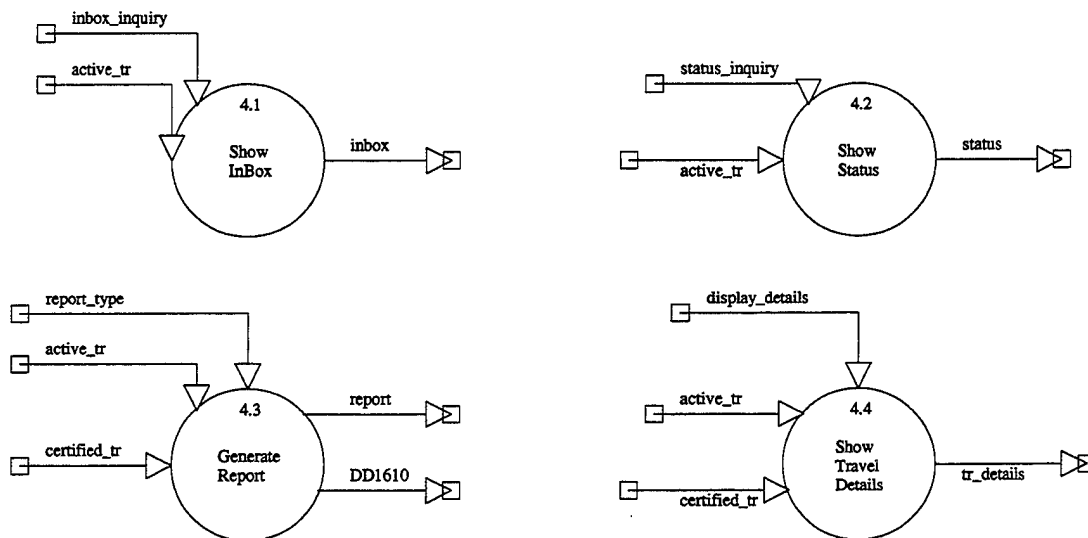

Figure 8. INQUIRIES process.

5.3 Processing Narration. Having captured the flow of information and identified data objects, each transformation can be further expanded by using the notation of structured English.

In this quasi-formalism, basic procedural constructs are combined with English phrases to give concise descriptions for each major operation listed in the prescribed tasks analysis given in section 4.

E1 Security

E11 Login

- Input — userid, passwd
- Process:
 - REPEAT
 - GET from user the userid, passwd
 - UNTIL VALID userid, passwd
 - ALLOW login
- Output — N/A

E12 Role

- Input — role, action
- Process
 - GET from EMPLOYEE the role using requester_userid
 - IF VALID action for role THEN
 - EXECUTE action
 - ELSE
 - NULL
 - ENDIF
- Output — action_results

E2 Prepare Travel Request

E21 Create new traveler profile

- Input — tr, requester_userid, user_info, profile_info
- Process 1.1
 - GET from EMPLOYEE the user_info using requester_userid

- GET from user traveler_ssn, traveler_grade, atm_status, jo_no
- SET in tr the requester_userid
- SET in tr the user_info using user_info
- SET in tr the profile_info
- Output — blank_tr

E22 Fill in travel request

- Input — blank_tr, purpose_tdy, proceed_date, itinerary_from, itinerary_to, itinerary_ret, poc_mode_trans, advance_auth, special_req, costs
- Process 1.2
 - GET from user the the purpose_tdy
 - GET from user the the proceed_date
 - GET from user the itinerary_from
 - DO WHILE there is another site to travel
 - GET from user the itinerary_to
 - SET in tr the itinerary_to
 - ENDDO
 - GET from user the itinerary_ret
 - SET in tr the itinerary_ret
 - GET from user the poc_mode_trans
 - SET in tr the poc_mode_trans
 - GET from user the advance_auth
 - SET in tr the advance_auth
 - GET from user the special_req
 - SET in tr the special_req
 - GET from user the costs
 - SET in tr the costs
- Output — partial_tr

E23 Fill in additional Information

- Input — partial_tr,tdy_site_info, lodging_info, rental_car_info, airline_info
- Process 1.3
 - GET from user the tdy_site_info, lodging_info, rentalcar_info, airline_info
 - SET in tr the tdy_site_info, lodging_info, rentalcar_info, airline_info
- Output —unfunded_tr

E24 Fill in fund source

- Input —unfunded_tr, fund_source
- Process 1.4
 - GET from user the fund_source
 - SET in tr the fund_source
- Output — funded_tr

E25 Correct travel request

- Input — rejected_tr, corrections
- Process 3.1
 - DISPLAY to user rejected_tr and explanation
 - DO WHILE there are more corrections
 - GET from user the corrections
 - SET in tr the corrections
 - ENDDO
- Output — corrected_tr

E26 Cancel request

- Input — active_tr, cancel_tr
- Process 3.2
 - DISPLAY to user the active_tr

- GET from user the cancel_tr
- PUT canceled_tr into CANCELED
- Output — canceled_tr

E3 Routing

E31 Automated routing

- Input — active_tr
- Process — TBD
- Output — active_tr

E32 Manual routing

- Input — active_tr
- Process — TBD
- Output — active_tr

E4 Approvals

E41 Requester approval

- Input — funded_tr, requester_approval
- Process 1.5
 - DISPLAY to user the funded_tr
 - GET from user the requester_approval
 - IF requester_approval is Yes, THEN
 - SET in tr the requester_approval to Yes
 - SET in tr the request_date to today's date
 - SET in tr the inbox_location to supervisor
 - ELSE
 - GET from user the explanation
 - SET in tr the requester_approval to No
 - SET in tr the explanation
 - SET in tr the inbox_location to secretary
 - ENDIF
- Output — requested_tr, rejected_tr

E42 Supervisory approval

- Input — requested_tr, supervisory_approval
- Process 1.6
 - DISPLAY to user the funded_tr
 - GET from user the supervisory_approval
 - IF supervisory_approval is Yes, THEN
 - SET in tr the supervisory_approval to Yes
 - SET in tr the request_date to today's date
 - SET in tr the inbox_location to budget
 - ELSE
 - GET from user the explanation
 - SET in tr the supervisory_approval to No
 - SET in tr the explanation
 - SET in tr the inbox_location to requester
 - ENDIF
- Output — completed_tr, rejected_tr

E43 Fund source approval

- Input — completed_tr, fund_source_approval, standard_doc_no
- Process 2.1
 - DISPLAY to user the completed_tr
 - GET from user the fund_source_approval
 - IF fund_source_approval is Yes, THEN
 - SET in tr the fund_source_approval to Yes
 - SET in tr the inbox_location to certification
 - SET in tr the standard_doc_no
 - ELSE
 - GET from user the explanation
 - SET in tr the fund_source_approval to No
 - SET in tr the explanation

- SET in tr the inbox_location to requester
 - ENDIF
 - Output — certifiable_tr, rejected_tr
- E5 Interface with legacy systems
- E51 Build block
- Input — N/A
 - Process 2.3
 - PUT to SOMARDS the block
 - GET from SOMARDS the return_message
 - Output — N/A
- E52 Certify funds
- Input — certifiable_tr
 - Process 2.2
 - GET from certifiable_tr the funds
 - PUT to SOMARDS the block, funds
 - GET from SOMARDS the return_message
 - IF return_message is OK, THEN
 - SET in tr the certification to Yes
 - ELSE
 - SET in tr the to certification to No
 - SET in tr the explanation to return_message
 - SET in tr the inbox_location to requester
 - ENDIF
 - Output — certified_tr, rejected_tr
- E53 Reconcile
- Input — N/A
 - Process 2.4

- PUT to SOMARDS the block, reconcile
- GET from SOMARDS the return_message
- Output — N/A

E6 Inquiries

E62 Status

- Input — active_tr
- Process 6.2
 - GET current status from ACTIVE
 - DISPLAY to user the status
- Output — status

E63 Generate Report

- Input — active_tr, report_type
- Process 6.3
 - DISPLAY to user report
 - DISPLAY to user active_tr
- PRINT DD1610
- Output — report, DD1610

E64 Show Travel Details

- Input — active_tr, display details
- Process 6.4
 - DISPLAY to user tr_details
 - PRINT tr_details
- Output — tr_details

E7 Navigation

E71 Navigate

- Input — TBD
- Process — TBD
- Output — TBD

E72 Logout

- Input — N/A
- Process — TBD
- Output — N/A

6. Data Dictionary

While DFDs and pseudo-code (structured English) are important to system specifications, additional information is required for a complete analytical model. The content of each data or control item should be more fully identified. A data dictionary is a quasi-formalism for describing content of information as it flows through the system. The standard notation conventions are

<u>Notation</u>	<u>Meaning</u>
=	is composed of
+	and
[]	either - or
{ } ⁿ	n repetitions of
()	optional data
* *	comments

Travel 1.0's data dictionary appears next. Each left-handed element is taken from the DFD and the Process Narrative model of the system. Each of these data items is then given an expanded, unambiguous definition in the right-hand column.

acct_citation = *Accounting Citation*
 {alphanumeric}

action = **

ACTIVE = {active_tr}

active_tr = *Travel Request at some point in the approval cycle*

advance = *Amount of advance*
units: dollars

advance_auth = *Advance authorized*
["Yes" | "No"]

advance_info = **
[advance_auth + advance]

air_cost = *Airfare*
units: dollars

airline_info = **
[airline_info_to + airline_info_ret]

airline_info_ret = *Airline information return trip*
[r_from_airport + r_depart_flight_no + r_depart_city +
r_depart_state + r_depart_date + r_depart_time + r_to_airport +
r_connection_flight_no + r_connection_city + r_connection_state
+ r_connection_date + r_connection_time + r_arr_airport
r_arr_city + r_arr_state + r_arr_date + r_arr_time]

airline_info_to = *Airline information to destination*
[from_airport + depart_flight_no + depart_city + depart_state
+depart_date + depart_time + to_airport + connection_flight_no +
connection_city + connection_state + connection_date +
connection_time + arr_airport + arr_city + arr_date + arr_state +
arr_time]

arr_airport = *Arriving to airport*
{alphabetic_character}

arr_city = *Arriving to city*
{alphabetic_character}

arr_date = *Arriving Date*
format: MMDDYY
{date}

arr_state = *Arriving State*
{legal_character}

arr_time = *Arriving Time*
{numeric_digit}

atm_status = **
{alphabetic_character}

batch_no = *SOMARDS batch number*

be_passenger = *Will be a passenger in POV or rental car*
 ["Yes | No"]

blank_tr = *Travel Request with the requester and requester profile info
 filled* [requester_userid + user_info +
 profile_info]

blk_no = *SOMARDS block number*
 "ARL"

blk_tkt_dt = *SOMARDS block ticket date*
 format: MMDDYY
 {date}

block = *SOMARDS build block data*
 [trns_cd + user_auth_key + cmd_dsg + update_code + blk_no +
 blk_tkt_dt + tot_blk + batch_no + tot_batch]

boq = *Government Quarters*
 ["Yes | No"]

CANCEL = {canceled_tr}

cancel_tr = *Travel Request canceled by traveler, supervisor or budget*

canceled_tr = *Travel Request that has been canceled*
 [active_tr + cancel_tr]

certifiable_tr = *Travel Request that has fund source approval*
[completed_tr + fund_source_approval]

certification = *SOMARDS Certification*
["Yes | No"]

certified_pr = *Travel Request that has been certified by SOMARDS*
[certifiable_tr + certification]

city = **
{alphabetic_character}

completed_tr = *Travel Request that has been approved by the supervisor*
[requested_tr + supervisory_approval]

connection_city = **
{alphabetic_character}

connection_date = **
format: MMDDYY
{date}

connection_flight_no = **
{alphanumeric}

connection_state = **
{legal_character}

connection_time = **
 {numeric_digit}

corrected_tr = *Travel request that has been corrected by the user*
 [rejected_tr + corrections]

corrections = *Corrections to a rejected travel request*

costs = *Total estimated cost of tdy*
 [perdiem_cost + air_cost + other_cost + registr_cost + etc-costs]
 units: dollars

cum_btch_value = *SOMARDS cumulative batch total for the days certification*
 units: dollars

DD1610 = *Printout of form DD1610*

depart_flight_no = *Departure Flight Number*
 {alphanumeric}

depart_city = *Departure City*
 {legal_character}

depart_date = *Departure Date*
 format: MMDDYY
 {date}

department = *Organization Element(Dir/Div/Branch)*
 {legal_character}

depart_state = *Departure State*
{legal_character}

depart_time = *Departure Time*
{numeric_digit}

display_details = *Display to user specific travel information*

EMPLOYEE = {employee}

employee = *Employee information - the bare minimum should contain*
[user_info + {roles}]

eor = *Funding element of resource*
{alphanumeric}

etc_costs= *Other costs*
units: dollars

explanation = *Rejection, cancellation, or return explanation*
{legal_character}

first_name = *A person's first name*
{alphabetic_character}

from_airport = *Departure airport*
{alphabetic_character}

from_city = *Departure city*
 {legal_character}

from_date = *Departure date*
 format: DD-MON-YY
 {date}

from_mode_trans = *Mode of transportation "TO" the TDY site*
 {legal_character}

from_state= *Departure State*
 {legal_character}

fund_source = **
 [jo_no + acct_citation + eor_1 + eor_2]
 {alphanumeric}

fund_source_approval = *Budget Analyst approval of fund source*
 ["Yes | No"]

funded_tr = *Travel request with a fund source*
 [unfunded_tr + fund_source]

funds = *Funding information for SOMARDS certification*
 [trns_cd + user_auth_key + cmd_dsg + update_code + blk_no +
 blk_tkt_dt + batch_no + rej_rept_director + doc_ref_no + jo_no +
 eor + act_amt]

gov_installation = *Name of government installation*
{alphabetic_character}

gov_phone = *Government installation phone number*
{numeric_digit}

grade = *Traveler's grade*
{alphanumeric}

have_passenger = *Will have passenger(s) in POV or rental car*
["Yes | No"]

hotel_address = **
{alphanumeric}

hotel_name = **
{alphabetic_character}

hotel_phone = **
{numeric_digit}

in_around_tdy = *Rental car authorized in/around TDY site*
[Yes|No]

inbox = *Travel requests requiring action from user*
{active_tr}

inbox_inquiry = **
TBD

inbox_location = *Current Travel Request Location*
TBD

itinerary_info = **
[itinerary_from + itinerary_to + itinerary_ret]

itinerary_from = *Traveler's "FROM" itinerary information*
[from_state + from_city + from_date +
from_mode_trans]

itinerary_ret = *Traveler's "RETURN" itinerary information*
[ret_state + ret_city + ret_date +ret_mode_trans]

itinerary_to = *Traveler's "To" itinerary information*
[to_state + to_city + to_date + tdy_days + perdiem +
to_mode_trans]

jobtitle= *Official title of user*
{alphabetic_character}

jo_no = *Funding Job Order Number*
{alphanumeric}

last_name = *A person's last name*
{alphabetic_character}

leave_auth = *Leave authorized during TDY*
[Yes|No]

leave_days = *Number of leave days taken*
 {numeric_digit}

location = *Official duty station*
 {alphanumeric}

lodging_info = *Travel lodging information*
 [boq + gov_installation + gov_phone +hotel_name +
 hotel_phone + hotel_address + lodging_remarks]

lodging_remarks = *Remarks pertaining to lodging accommodations*
 {alphanumeric}

mail_stop = *Mail stop or department*
 {legal_character}

mi = *Middle initial*
 {alphabetic_character}

mode_type = *Type of Transportation*
 {legal_character}

name = **
 [first_name + last_name + mi]
 {alphabetic_character}

other_cost = *Total estimated "OTHER" costs*
 [rental_cost + etc_cost]
 units: dollars

partial_tr = **
 [blank_tr + purpose_tdy + proceed_date, itinerary +
 leave_days + costs]

passenger = *Passenger in POV or rental car*
 [have_passenger + be_passenger]

perdiem = *Perdiem rate*
 units: dollars

perdiem_cost = **
 [perdiem * tdy_days]
 units: dollars

phone_no = *Phone number*
 {numeric_digit}

pov_mode_trans_info = **
 [pov_mode_trans + pov_to_from_mmode]

pov_mode_trans= * Traveler selects reason for using his/hers POV (more
 advantegeous to gov. or limited reimbursement
 from gov)*

pov_passenger= *Name of gov. employee that the traveler will be a passenger to
 his/hers POV*
 {alphabetic_character}

pov_to_from_mmode = *Traveler uses POV to/from rental car pick-up*
 [Yes | No"]

pov_type= *Type of POV*
 {alphabetic_character}

proceed_date = *Proceed date of TDY*
 format: MMDDYY
 {date}

profile_info = *Traveler's profile information*
 [ssn + grade + atm_status + jo_no]

purpose_tdy = *TDY purpose*
 {alphabetic_character}

reconcile = *End of the day SOMARDS reconcile info*
 [trns_cd + user_auth_key + cmd_dsg + update_code + blk_no +
 blk_tkt_dt + batch_no + tot_blk + tot_batch + ty_act_cd +
 cum_btch_value + variance]

registr_auth = *Registration fees authorized*
 [Yes|No]

registr_cost = *Registration fee not included on DD1556*
 units: dollars

rejected_tr = *Travel request that has been rejected by Supervisor or Budget*
 [active_tr + explanation]

rej_rept_director = *SOMARDS REJ-REPT-DIRECTOR*
"R"

remarks= **
{alphanumeric}

rental_car_agency = *Name of rental car agency*
{alphabetic_character}

rental_car_info = *Rental car information*
rental_car_agency + rental_car_phone

rental_car_phone = *Rental car agency phone no.*
{numeric}

rental_cost = *Rental car cost*
[tdy_days * 35.00]
units: dollars

rental_passenger= *Name of gov.employee that the traveler will be
passenger to his/hers rental car*
{alphabetic_character}

report = **
TBD

report_type = *Type of report to generate*
TBD

request_date = *System date*

request_info = **
 [purpose_tdy + proceed_date + itinerary_info + pov_mode_trans,
 advance_info + special_req + costs]

requested_tr = * Travel request that has been approved by the requester*
 [funded_tr + requester_approval]

requester_approval = * Approval from requester*
 ["Yes | No"]

requester_userid = **
 {userid}

ret_city = * Return City*
 {legal_character}

ret_date = * Return Date*
 format: MMDDYY
 {date}

ret_mode_trans = * Mode of transportation from the TDY site*
 {legal_character}

ret_state = * Return State*
 {legal_character}

return_message = * Message returned from SOMARDS process*
 [processing complete | bad user_auth_key |
 wrong update code | blk_no/blk_tkt_dt already exists |
 accounting class displayed | blk_no/blk_tkt_dt doesnot
 exist | invalid jo_no| invalid eor | insufficient funds | duplicate
 comt_ref_no | cum_btch_value | make changes | variance]

r_arr_airport= * Arrival airport return trip*
 {alphanumeric}

r_arr_city= * Arrival City name return trip*
 {legal_character}

r_arr_date= * Arrival date return trip*
 format: MMDDYY
 {date}

r_arr_state = * Arrival state return trip*
 {legal_character}

r_arr_time= * Arrival time return trip*
 {numeric_digit}

r_connection_city= * Connection City name return trip*
 {legal_character}

r_connection_date= * Connection flight date return trip*
 format: MMDDYY
 {date}

r_connection_flight_no = * Connection flight time return trip*
{alphanumeric}

r_connection_state = * Connection flight state return trip*
{legal_character}

r_connection_time = * Connection flight time return trip*
{numeric_digit}

r_depart_city = * Departure city return trip*
{alphabetic_character}

r_depart_date= * Departure date return trip*
format: MMDDYY
{date}

r_depart_flight_no = * Departure flight no return trip*
{alphanumeric}

r_depart_state = * Departure State return trip*
{legal_character}

r_depart_time = * Departure Time return trip*
{numeric_digit}

r_from_airport = * Return from airport information*
[airline_info_ret]

r_to_airport = * Airport name return trip*
{alphanumeric}

role = * user role*
{alphanumeric}

share_rental= * Traveler will share driving of rental car with other gov.
employees.
[Yes|No]

special_req = * Other special requirements about the TDY*
[passenger + registr_auth + leave_auth + leave_days +
trip_report + rental_car_auth]

ssn= * Social security number*
{numeric_digit}

standard_doc_no= * Standard document number*
{alphanumeric}

state = * State or province*
{legal_character}

status = **
TBD

status_inquiry = **
TBD

supervisory_approval = * Approval from supervisor*
["Yes | No"]

tdy_days = * Number of TDY days
[ret_date - proceed_date]
{numeric_digit}

tdy_poc_name = *TDY Point Of Contact*
{alphabetic_character}

tdy_poc_phone = * TDY phone*
{numeric}

tdy_site_info = **
[tdy_site + tdy_poc_name + tdy_phone + tdy_site_remarks]

tdy_site_remarks = *TDY site remarks*
{alphanumeric}

tdy_site = *TDY site name*
{alphanumeric}

to_airport = * Connecting flight to airport*
{alphabetic_character}

to_city = *Destination City*
legal_character}

to_date = *Arrival Date*
 format: MMDDYY
 {date}

to_from_mmode = *Rental car authorized to/from main mode*

to_from_tdy = *Rental car authorized to/from TDY site*

to_mode_trans = *Mode of transportation AT the TDY site*
 {legal_character}

to_state = *Destination State*
 {legal_character}

tot_batch = *SOMARDS batch number*
 units: dollars
 ["0.00" | cum_btch_value]

tot_blk = *SOMARDS total block*
 units: dollars
 ["0.00" | cum_btch_value]

tr = *Travel Request*

tr_details = *Travel specific information*
 [tdy_site_info, lodging_info, rental_car_info, airline_info]

trip_report = *Trip report required*
 ["Yes | No"]

trns_cd = *SOMARDS transaction code*
 ["003" | "004" | "310"]

ty_act_cd = *SOMARDS action code*
 "C"

unfunded_tr= *Partial travel request with additional information*
 [partial_tr + tr_details]

update_code = *SOMARDS update code*
 ["CM" | "NM"]

user_auth_key = *SOMARDS user authorization key*
 {alphanumeric}

user_info = *User information*
 [name + phone_no + department + location + title]

userid = **
 {alphanumeric}

variance = *SOMARDS variance between tot_batch and
 cum_btch_value - should be 0.00*
 units: dollars

variation = *Authorized itinerary variation*
 ["Yes | No"]

INTENTIONALLY LEFT BLANK.

7. References

1. Business Process Reengineering Project. "To-Be Model: ARL Travel Orders." U.S. Army Research Laboratory, Aberdeen Proving Ground, MD, March 1997.
2. Business Process Reengineering Project. "ARL Travel System: Report Specifications (DRAFT)." U.S. Army Research Laboratory, Aberdeen Proving Ground, MD, March 1997.
3. Gravels, B., J. Kelly, and V. Smith. "Travel Automated System: Software Development Plan." TAS-97-01, Aberdeen Proving Ground, MD, U.S. Army Research Laboratory, May 1997.

INTENTIONALLY LEFT BLANK.

<u>NO. OF COPIES</u>	<u>ORGANIZATION</u>
2	DEFENSE TECHNICAL INFORMATION CENTER DTIC DDA 8725 JOHN J KINGMAN RD STE 0944 FT BELVOIR VA 22060-6218
1	HQDA DAMO FDQ D SCHMIDT 400 ARMY PENTAGON WASHINGTON DC 20310-0460
1	OSD OUSD(A&T)/ODDDR&E(R) R J TREW THE PENTAGON WASHINGTON DC 20301-7100
1	DPTY CG FOR RDE HQ US ARMY MATERIEL CMD AMCRD MG CALDWELL 5001 EISENHOWER AVE ALEXANDRIA VA 22333-0001
1	INST FOR ADVNCD TCHNLGY THE UNIV OF TEXAS AT AUSTIN PO BOX 202797 AUSTIN TX 78720-2797
1	DARPA B KASPAR 3701 N FAIRFAX DR ARLINGTON VA 22203-1714
1	NAVAL SURFACE WARFARE CTR CODE B07 J PENNELLA 17320 DAHLGREN RD BLDG 1470 RM 1101 DAHLGREN VA 22448-5100
1	US MILITARY ACADEMY MATH SCI CTR OF EXCELLENCE DEPT OF MATHEMATICAL SCI MAJ M D PHILLIPS THAYER HALL WEST POINT NY 10996-1786

<u>NO. OF COPIES</u>	<u>ORGANIZATION</u>
1	DIRECTOR US ARMY RESEARCH LAB AMSRL DD J J ROCCHIO 2800 POWDER MILL RD ADELPHI MD 20783-1145
1	DIRECTOR US ARMY RESEARCH LAB AMSRL CS AS (RECORDS MGMT) 2800 POWDER MILL RD ADELPHI MD 20783-1145
3	DIRECTOR US ARMY RESEARCH LAB AMSRL CI LL 2800 POWDER MILL RD ADELPHI MD 20783-1145
	<u>ABERDEEN PROVING GROUND</u>
4	DIR USARL AMSRL CI LP (305)

NO. OF
COPIES ORGANIZATION

7 DIRECTOR
US ARMY RESEARCH LAB
AMSRL IS
J GRILLS
AMSRL IS ES
R ROSEN
AMSRL CS
COL K LOGAN
AMSRL CI E
W JERNIGAN
W MCCOY
B SCHALLHORN
AMSRL SE S
A SINDORIS
2800 POWDER MILL RD
ADELPHI MD 20783-1145

1 DIRECTOR
US ARMY RESEARCH LAB
AMSRL EA
P STAY
WSMR NM 88002-5501

ABERDEEN PROVING GROUND

10 DIR USARL
AMSRL CI N RADHAKRISHNAN
AMSRL CI E D ULERY (6 CPS)
AMSRL HR SF B AMREIN
AMSRL WM IM R MCGEE
AMSRL CS AP D ORE

REPORT DOCUMENTATION PAGE			<i>Form Approved</i> OMB No. 0704-0188	
Public reporting burden for this collection of information is estimated to average 1 hour per response, including the time for reviewing instructions, searching existing data sources, gathering and maintaining the data needed, and completing and reviewing the collection of information. Send comments regarding this burden estimate or any other aspect of this collection of information, including suggestions for reducing this burden, to Washington Headquarters Services, Directorate for Information Operations and Reports, 1215 Jefferson Davis Highway, Suite 1204, Arlington, VA 22202-4302, and to the Office of Management and Budget, Paperwork Reduction Project(0704-0188), Washington, DC 20503.				
1. AGENCY USE ONLY (Leave blank)	2. REPORT DATE August 1999	3. REPORT TYPE AND DATES COVERED Final, Jan-Jul 1997		
4. TITLE AND SUBTITLE Travel Software Requirements Analysis: A C-BASS Component			5. FUNDING NUMBERS AC9UA4EC	
6. AUTHOR(S) Barbara F. Gravels and Vickie L. Smith				
7. PERFORMING ORGANIZATION NAME(S) AND ADDRESS(ES) U.S. Army Research Laboratory ATTN: AMSRL-CI-AS Aberdeen Proving Ground, MD 21005-5067			8. PERFORMING ORGANIZATION REPORT NUMBER ARL-MR-453	
9. SPONSORING/MONITORING AGENCY NAMES(S) AND ADDRESS(ES)			10. SPONSORING/MONITORING AGENCY REPORT NUMBER	
11. SUPPLEMENTARY NOTES				
12a. DISTRIBUTION/AVAILABILITY STATEMENT Approved for public release; distribution is unlimited.			12b. DISTRIBUTION CODE	
13. ABSTRACT (Maximum 200 words) This document presents the software requirements analysis for Travel, Version 1.0, a component of the Corporate Business Application Software System (C-BASS) that automates travel requests for the U.S. Army Research Laboratory (ARL). The document follows the process of structured analysis, or step-wise refinement of requirements, as applied to the development of a prototype for the full version of Travel. The "environmental model" includes a high-level system description, followed by a context diagram and a list of events to which the system must respond. The "behavioral model" includes a data flow diagram (DFD) for each of the four Travel 1.0 subsystems. From this representation, the basic functional specifications are derived and represented in structured English (or program design language). The final segment of the document includes a data dictionary that defines all data and control items.				
14. SUBJECT TERMS Travel, Software Requirements Analysis, Software Travel Orders, C-BASS			15. NUMBER OF PAGES 50	
			16. PRICE CODE	
17. SECURITY CLASSIFICATION OF REPORT UNCLASSIFIED	18. SECURITY CLASSIFICATION OF THIS PAGE UNCLASSIFIED	19. SECURITY CLASSIFICATION OF ABSTRACT UNCLASSIFIED	20. LIMITATION OF ABSTRACT UL	

INTENTIONALLY LEFT BLANK.

USER EVALUATION SHEET/CHANGE OF ADDRESS

This Laboratory undertakes a continuing effort to improve the quality of the reports it publishes. Your comments/answers to the items/questions below will aid us in our efforts.

1. ARL Report Number/Author ARL-MR-453 (Gravels) Date of Report August 1999

2. Date Report Received _____

3. Does this report satisfy a need? (Comment on purpose, related project, or other area of interest for which the report will be used.) _____

4. Specifically, how is the report being used? (Information source, design data, procedure, source of ideas, etc.) _____

5. Has the information in this report led to any quantitative savings as far as man-hours or dollars saved, operating costs avoided, or efficiencies achieved, etc? If so, please elaborate. _____

6. General Comments. What do you think should be changed to improve future reports? (Indicate changes to organization, technical content, format, etc.) _____

CURRENT
ADDRESS

Organization

Name

E-mail Name

Street or P.O. Box No.

City, State, Zip Code

7. If indicating a Change of Address or Address Correction, please provide the Current or Correct address above and the Old or Incorrect address below.

OLD
ADDRESS

Organization

Name

Street or P.O. Box No.

City, State, Zip Code

(Remove this sheet, fold as indicated, tape closed, and mail.)
(DO NOT STAPLE)