

REPORT DOCUMENTATION PAGE

Form Approved
OMB No. 0704-0188

Public reporting burden for this collection of information is estimated to average 1 hour per response, including the time for reviewing instructions, searching existing data sources, gathering and maintaining the data needed, and completing and reviewing the collection of information. Send comments regarding this burden estimate or any other aspect of this collection of information, including suggestions for reducing this burden to Washington Headquarters Services, Directorate for Information Operations and Reports, 1215 Jefferson Davis Highway, Suite 1204, Arlington, VA 22202-4302 and to the Office of Management and Budget, Paperwork Reduction Project (0704-0188), Washington, DC 20503.

1. AGENCY USE ONLY (Leave blank)		2. REPORT DATE January 5, 1998	3. REPORT TYPE AND DATES COVERED Final 05/05/97 to 01/05/98	
4. TITLE AND SUBTITLE Portable Total Integrated Scatter and Retro-Reflectance Instrument			5. FUNDING NUMBERS 5773600 297 4753 663005 000000 00000 65502F 503000 F03000	
6. AUTHORS John S. Harchanko				
7. PERFORMING ORGANIZATION NAME(S) AND ADDRESS(ES) AZ Technology, Inc. 4901 Corporate Drive Suite 101 Huntsville, AL 35805			8. PERFORMING ORGANIZATION REPORT NUMBER 97-4-344-007	
9. SPONSORING / MONITORING AGENCY NAME(S) AND ADDRESS(ES) USAF Applied Technology Division AEDC/DOT Attn: Kevin Zysk 1099 Avenue C Arnold AFB, TN 37389-9011			10. SPONSORING / MONITORING AGENCY REPORT NUMBER FA0600-97-C-0012	
11. SUPPLEMENTARY NOTES				
12a. DISTRIBUTION / AVAILABILITY STATEMENT No restriction			12b. DISTRIBUTION CODE	
13. ABSTRACT (Maximum 200 words) A summary of the work performed to determine the feasibility of manufacturing a portable instrument to measure the Total Integrated Scatter and Retro-Reflectance with respect to wavelength is given. The results of a fully functioning breadboard which measures the TIS and Retro-Reflectance of a surface at a laser wavelength are presented. The breadboard demonstrates the enabling technology of a novel, patented ellipsoidal cavity (patent #5,659,397) that is significantly smaller than conventional methods for making TIS and Retro-Reflectance measurements. The performance of the ellipsoidal cavity was demonstrated and a design study to adapt this technology for use in conjunction with a scanning FTIR spectrometer was performed. TIS and Retro-Reflectance measurements of metals and thermal control coating are presented. A Lambertian study of Labsphere's SRS-99 Spectralon™ and IRT-94 InfraGold™ are presented. In addition, an attempt to measure the retro-reflectance of a solid model rocket plume is presented.				
14. SUBJECT TERMS TIS, Backscatter, Retro-Reflectance, Portable FTIR, Rocket Plume			15. NUMBER OF PAGES	
17. SECURITY CLASSIFICATION OF REPORT Unclassified			16. PRICE CODE	
18. SECURITY CLASSIFICATION OF THIS PAGE Unclassified		19. SECURITY CLASSIFICATION OF ABSTRACT Unclassified		20. LIMITATION OF ABSTRACT UL

**Final Technical Progress Report
for
May 5, 1997 through January 5, 1998**

**Portable Total Integrated Scatter and
Retro-Reflectance Instrument**

Contract Number F40600-97-C-0012

January 5, 1998

Report 97-4-344-007

Prepared for:

**The Department of the Air Force
Arnold Engineering and Development Center**

Prepared by:

**DISTRIBUTION STATEMENT A
Approved for Public Release
Distribution Unlimited**

AZtek

**AZ Technology, Inc.
4901 Corporate Drive, Suite 101
Huntsville, AL 35801**

19990818 227

CONTENTS

	<u>Page</u>
PREFACE	1
INTRODUCTION	5
1.0 APPARATUS	6
2.0 PROCEDURE	8
3.0 RESULTS AND DISCUSSION	9
4.0 CONCLUDING REMARKS	12
5.0 REFERENCES	12

ILLUSTRATIONS

<u>Figure</u>	<u>Page</u>
1. Hemispherical Collection Cavity	13
2. SMART-TIS Concept	13
3. Laser Section	14
4. Measurement Section	14
5. Electrical/Electronic Block Diagram	15
6. Lambertian Study of Spectralon™ SRS-99	15
7. Lambertian Study of Infragold™ IRT-94	16
8. System Spectral Response	16

TABLES

<u>Table</u>		<u>Page</u>
1.	RMS Surface Roughness Measurement Comparison	17
2.	Retro-Reflectance of Commonly Available Materials	17
3.	Near-Normal Hemispherical Reflectance Measurement Comparison.....	17
4.	Solid Model Rocket Test Firing Summary	17

INTRODUCTION

Characterizing the optical properties of materials is becoming an increasing challenge as new materials, composite structures, coatings, etc. are constantly being developed. The ability to accurately measure the optical signature, specifically the Total Directional-Hemispherical Reflectance and the Retro Reflection (or backscatter) as well as the Total Integrated Scatter (TIS) from a surface, is useful in many applications including thermal control, surveillance, interceptors, camouflage, targets and decoys. In using laser designation systems (or other optical designators), the backscatter from a target determines the amount of detectable signal which is available for a weapons system. Minimizing the backscatter or bi-directional TIS from a target surface allows the signal to be "lost" in the background of noise, thus preventing a target lock-on. As new enemy hardbody materials are being developed, the spectral properties of the retroreflectance and TIS can be explored in order to determine possible weaknesses in their backscatter minimization attempts. Conversely, if the retroreflectance or TIS from a particular surface is known to be very large within a certain IR wavelength range, then a laser can be chosen to help maximize the return signal. Spectral information about the backscatter and reflectance properties of a surface are extremely important in this type of research and characterization. New coatings and materials are constantly being developed and must be characterized by their spectral scattering and reflectance properties.

The goal of this effort was to determine the feasibility of designing and manufacturing a portable instrument to measure TIS and retro-reflection properties of surfaces. This instrument would not only be extremely useful in characterizing the TIS/backscatter signature of a target, but also in developing new coatings to tailor the effect of scattering, measuring the RMS roughness of high-energy laser optics, production line monitoring, etc. Portability of the instrument would be a major advantage in signature characterization since witness samples may not be available and measuring the actual hardware using existing laboratory instrument would be all but impossible.

By leveraging the technology developed for a Total Emittance Measurement Portable (TEMP-2000) instrument, developed by AZ Technology, it is now possible to make a portable TIS instrument. Previous measurement methods used large, bulky optical systems in order to define and separate the specular and diffuse reflections from a surface. The TEMP-2000 is the first truly portable unit able to measure total hemispherical and total normal emissivity by virtue of a novel, patented optical component*. The optical component functions as a hemispherical collector cavity by collecting a 2π steradian cone from the sample and directing it to the detector located at the other end of the collector. Entrance holes were cut into the side of the cavity to allow the incident beam to illuminate the sample at various angles. Corresponding exit holes were cut into the opposite side of the cavity from the entrance holes in order to allow the specularly reflected beam to exit the cavity. The retro-reflected beam is reflected back on itself and exits out the same entrance hole. The specular, diffuse and retro-reflected beams are thus separated for optical detection. This concept is shown in Fig. 1. The outside dimensions of the cavity are approximately 2 inches tall with a diameter of 1.5 inches at the largest point. From the

* Patent #5,659,397

size of the cavity, it is easy to see how a small, portable instrument can be fabricated. Note that most of the exit holes are omitted for clarity and that only a small portion of the diffuse beam is shown: also for clarity. The holes cut into the cavity subtend a very small portion of the total solid angle of the cavity and therefore do not appreciably affect the measurement.

Since this is the first time the hemispherically collecting ellipsoidal cavity has been used for scatter measurements, it was necessary to verify the measurement performance of a system using this optic as the enabling technology. Phase I of this effort was to design, build, assemble and test a small breadboard system which demonstrated the measurement performance of the collection cavity as well as the feasibility of building a small, portable instrument. This report documents the configuration of the instrument and the measurement results. The measurements include TIS, retro-reflectance, hemispherical reflectance and Lambertian properties of several sample surfaces. In addition, the retro-reflectance of a solid model rocket plume was measured.

It was desirable to be able to measure the scatter properties of a surface with respect to incident angle (as demonstrated in the Lambertian properties measurement). The instrument measures the scatter properties at 15°, 30°, 45°, 60°, 75° angle of incidence (AOI). The Phase I instrument was therefore named: Spectral Multi-Angle Retroreflectance - Total Integrated Scatter (SMART-TIS). Although the Phase I instrument uses a laser as the source, future versions developed in Phase II and III, will have the capability to measure the scatter properties as a function of wavelength.

1.0 APPARATUS

A simple concept drawing of the optical system is shown in Fig. 2. The dashed lines in this figure represent an example of other possible beam paths for some of the different angles of incidence. The laser, the half-wave plate, the reference detector, and the retro-detector all rotate together about the pivot point. This rotation, working in conjunction with the first elliptical mirror, varies the angle of incidence on the sample. While a laser ($\lambda = 635\text{nm}$) is shown as the source in this illustration, it can be replaced with a broadband source such as a tungsten-halogen bulb or, for measurements farther in the infrared (IR), an open air igniter would serve quite well as an IR source. Note that in this simple concept drawing, the system is two-dimensional. When the system is shown to be three dimensional, as in later figures, the elliptical mirrors will be referred to as the ellipsoidal mirrors in order to more accurately describe their true shape.

In order to more clearly depict the system, it was broken into two sections. The first section of the Phase I TIS/Retro-Reflectance instrument is illustrated in Fig. 3 and consists of the laser, beam splitter, and all components in between. The laser beam used in this instrument is linear polarized 100:1 and produces a rectangular beam which is limited to a circular beam by a 1mm diameter aperture. Fig. 3 shows a tuning fork chopper as the first component in the optical path. This was used to determine if mechanical modulation produced a higher detector output than electronic modulation. Electronic modulation proved to be better than the tuning fork chopper in terms of system simplicity and maximizing detector output, so the tuning fork chopper was removed from the beam path. The beam then passed through a spatial filter which consisted of a

10X microscope objective and a 30 micrometer diameter pinhole. The focusing lens assembly refocused the laser beam at the rotation axis of the rotation stage and also matched the f-number of the remainder of the system. The polarization rotator consists of a half-wave plate in order to rotate the plane of polarization of the laser. The non-polarizing beam splitter (which is centered on the rotation axis so that the laser is focused exactly in the middle of the beam splitter) transmitted 50% of the energy to the first ellipsoidal mirror and reflected 50% of the laser energy to the laser incident (or reference) detector.

One focal point of the ellipsoidal mirror also coincided with the rotation axis of the rotation stage while the second focal point coincided with the sample. Both ellipsoidal mirrors consist of a 3/4-inch wide section of an ellipsoid and are not full ellipsoids. By rotating the rotation stage about its axis, the beam can be effectively directed onto the sample at various angles as shown in Fig. 4. Note that Fig. 4 is showing a top view with respect to Fig. 3. Note that the retro-reflected beam is shown in this figure as a dashed line. The hemispherical collection cavity is also ellipsoidal in shape and had one focal point correspond with that of the first ellipsoidal mirror. The purpose of the hemispherical collection cavity is to direct a full hemisphere (2π steradians) of the diffuse energy up to the diffuse detector located at the other end of the cavity. Note the conical apertures shown on the right-hand side of the hemispherical collection cavity which allow the incident energy into the hemispherical collection cavity. These holes are set at 15° , 30° , 45° , 60° and 75° with respect to the surface normal of the sample. A corresponding set of apertures is also drilled 180° opposite into the left-hand side of the cavity (not shown for clarity). These allow the specular energy to exit the cavity and strike the second ellipsoidal mirror which focuses this energy onto the specular detector. The second ellipsoidal mirror also has one of its focal points coincident with the first ellipsoidal mirror; the specular detector is placed at the other focal point of the second ellipsoidal mirror.

Extensive optical analysis of the system was performed in order to optimize the optical performance. While SYNOPSIS performed much of the analysis, there were geometrical considerations for which MathCAD was used such as determining the percent hole losses in the hemispherically collecting ellipsoidal cavity versus the size of the cavity for a constant beam convergence. In order to design the system, MicroStation CAD was used. This was an easy method to help set the f-number for the system and maintain the necessary physical clearances required for the rotation stage. SYNOPSIS was used to help determine the direction of the design and for the finishing touches. In addition, there was some error in the diamond machining of the two ellipsoidal mirrors. SYNOPSIS helped define the impact of the errors so that a decision to whether or not to remachine could be based on quantitative data. The error in machining the ellipsoidal mirrors was determined to be acceptable and the mirrors were not remachined.

Fig. 5 shows the electronic block diagram of the system. The lock-in amplifier is manufactured by Stanford Research Systems, Inc., and the laser and laser electronics are manufactured by Micro-Laser Systems, Inc. The function generator is manufactured by Wavetek and the multiplexer is simply a computer data switch rewired to minimize any crosstalk. The chopper

and chopper driver are manufactured by Electro-Optical Products Corporation and the detectors are silicon photodiodes manufactured by EG&G Judson.

2.0 PROCEDURE

The basic measurement procedure is to first calibrate the instrument using two calibration samples, one highly specular and the other highly Lambertian, of known total hemispherical reflectances. The unknown sample can then be placed against the measurement aperture and the various detector voltages are then recorded for later analysis. (During Phases II and III, the sample measurement and analysis will be automated and the instrument will simply display the results.) The raw output of the measurement is simply a series of detector voltages from which a TIS and Retro-Reflectance measurement are computed. The derivation and history of the TIS equation can be found in many sources, but perhaps the most complete and accurate is found in Jean Bennett's work¹. The retro-reflectance measurement has not had as much scientific scrutiny as the TIS measurement, so a good definition, albeit extremely simple, which fits the intended application of measuring hardbody signatures, is used.

The TIS equation used in this study is as follows:

$$TIS = \frac{V_D}{V_D + V_S} \left[\frac{R_L V_S}{R_S V_D} \right]_{CAL}$$

where V_D is the diffuse detector voltage, V_S is the specular detector voltage, R_L is the near-normal hemispherical reflectance of the Lambertian sample, R_S is the near-normal hemispherical reflectance of the specular sample, and the *CAL* subscript denotes the quantity which is referred to as the calibration factor. The calibration factor is derived by first measuring a specular sample of known reflectance and recording the specular detector reading only. Next, a Lambertian sample of known reflectance is measured and the diffuse detector reading only is recorded. These four quantities, then, make up the calibration factor. Note that the V_S and the V_D in the calibration factor is not the same as that outside the brackets. The detector voltages outside the brackets are recorded with the unknown sample placed against the sample aperture. Note that the instrument is aligned such that with no sample over the aperture, a true zero TIS and retro-reflectance value can be obtained.

Once the calibration factor is set at the beginning of a measurement session, it does not have to be measured again during that session; although it is a good idea to measure a series of unknown samples and then reverify the calibration factor. Note that the calibration of the instrument is performed at a 15° incidence angle so that the near-normal hemispherical reflectances of the calibration samples is still considered to be valid. The purpose of the calibration is to correct the difference in responsivities between the two detectors. For the various angles of incidence on the sample this should be a constant. To verify this, a separate test setup was made so that the detector output versus angle of incidence could be measured. The output versus angle of incidence was found to be very smooth and flat up to the limit of the measurement which was approximately 85°.

The measurement of retro-reflectance is much more simple by comparison. The instrument is designed to limit the retro-reflected energy to a certain solid angle at each angle on incidence on the sample. At 15° angle of incidence, the system limits the backscatter to approximately 0.06% of 2π steradians so that for a Lambertian surface of nearly 100% reflectance, the retro-reflectance detector output would be, by definition, 0.06%. In order to calibrate the instrument, a highly reflective ($R \geq 0.99$) Lambertian surface is placed against the sample aperture and the retro-reflectance detector is recorded. The unknown sample is then placed against the sample aperture and the detector reading is recorded and then scaled against the calibration reading to determine the percent retro-reflectance.

3.0 RESULTS AND DISCUSSION

The results of the SMART-TIS breadboard are quite convincing and show the instrument to be working well. There is considerable agreement between measurements made with SMART-TIS breadboard and other instruments. Approximately nine years ago, the University of Alabama in Huntsville (UAH) built a TIS breadboard based on a Coblenz Sphere arrangement¹. The measurements from the UAH breadboard were verified by a round-robin measurement between UAH and the Naval Warfare Center by Dr. Jean Bennett.

Two mirrored samples were obtained from UAH (Newport 1 and Newport 2) in order to determine the accuracy of the TIS measurement. The SMART-TIS obtained very good correlation with UAH's breadboard on the Newport 1 mirror. However, the correlation with the Newport 2 mirror showed some discrepancy. After researching the differences in the two readings, it was determined that the coating on the Newport 2 mirror had begun to degrade since UAH had measured the sample and thus the SMART-TIS was giving an accurate reading. This shows the utility of this type of instrument. For example, if the Newport 2 mirror had been measured by the SMART-TIS in the field, this instrument would have been able to quickly determine that the Newport 2 mirror had fallen below operational specifications. Because of the degradation of the Newport 2 mirror, it was dropped from further data analysis.

In order to determine the retro-reflectance measurement capability, several readily available samples were measured. These samples ranged from 0.06% to 0.5% backscatter of the original incident beam. In order to further demonstrate the utility and flexibility of the instrument, the combined SMART-TIS measurements of the diffuse and specular reflectance of a sample were compared against a commercial instrument: AZ Technology's Laboratory Portable SpectroReflectometer instrument (LPSR-200). This instrument measures the near-normal hemispherical reflectance of a sample from 250-2800nm within $\pm 1\%$ full scale. The hemispherical reflectance is defined as the reflectance of a surface within a 2π steradian hemisphere. In terms of the SMART-TIS measurement, the hemispherical reflectance, would be the sum of the specular and diffuse reflectances. One more study was performed in order to determine the diffuseness of two samples: Labsphere's Spectralon™ (SRS-99) and Infragold™ (IRT-94). The results of each of these tests are provided below.

For comparison purposes and to establish the accuracy of the breadboard, the results of the TIS measurements are shown in Table 1. These measurements were performed at 15° AOI in the case of the SMART-TIS breadboard and at a near-normal angle in the UAH breadboard instrument. The UAH breadboard instrument measured the samples using an unknown polarization angle while the SMART-TIS instrument illuminated the samples with linear polarized light oriented for maximum reflectance from a surface (E-field oscillations were parallel to the surface). The UAH breadboard utilized a laser at 532nm while the SMART-TIS utilized a 635nm laser. These differences should affect the comparative data very little. The difference that should produce the largest error is the difference in beam size on the sample. The UAH measurement kept the beam close to 1mm in diameter while the SMART-TIS breadboard had a spot size of approximately 0.25mm. The effect of the larger spot size was to average out any minute imperfections in the coating. Nevertheless, the measurements of the Newport mirror agree quite well.

Next, the retro-reflectance of several samples was measured with the SMART-TIS. Since it is relatively difficult (as compared to the TIS measurements) to obtain samples for which the retro-reflectance is known, Phase I of the project simply proved that a reasonable retro-reflectance measurement could be obtained. The results of this study are shown in Table 2.

It was determined that it should be possible to also use the detector readings from the diffuse, specular and retro-reflectance detectors to measure the directional-hemispherical reflectance of a surface and compare this measurement to that of AZ Technology's LPSR-200. The results of this measurement comparison clearly demonstrate the accuracy and utility of the breadboard. The results of this comparison are shown in Table 3. The breadboard directly measures the diffuse and specular reflectance. In order to obtain hemispherical data, the two are simply added together since the retro-reflectance is typically well less than 0.5%.

The samples were chosen to represent the range of samples that the actual Phase II instrument might encounter. The "Black Anodize" sample has directionally aligned machine marks on a substrate of 6061-T6 aluminum. The "S.A. Anodize" sample is the same substrate, but with a sulfuric acid anodize over the substrate. The "Indium" sample is a small block of fairly pure indium weighing approximately 1/4 pound. The "Diffuse Black" sample is an aluminum substrate spray coated with a specially formulated inorganic diffuse black baffle coating. The "Diffuse White" sample is that same substrate sprayed with a titanium-oxide pigment in a zinc orthotitanate binder. The "Nickel" sample is an aluminum substrate plated with electroless nickel. The "Spec Cal Mirror" sample is the same mirror that is used to calibrate the specular detector when performing a TIS measurement. The "Sand-Blasted Al" sample is a sand-blasted substrate of 6061-T6 aluminum.

Extremely good correlation was found between the two instruments. Note that the accuracy of the LPSR-200 is stated to be $\pm 3\%$ of full scale. The LPSR-200 measures a rectangle approximately 2.5mm x 7.5mm.

Finally, a study of the diffuse properties of two of Labsphere's standard materials was performed. The sample was placed at the sample aperture and the diffuse detector reading was recorded at the various input angles. The results of this study are shown in Fig. 6 and Fig. 7. This data shows that both samples diverge from a perfect Lambertian scatter. The SRS-99 sample is very Lambertian out to 60° (at 635nm) while the IRT-94 sample diverges from Lambertian very quickly (at 635nm). There is no other data readily available for either sample at 635nm, but the data available for the spectralon samples has enough variability with wavelength to suggest that this data is valid.

In order to measure the retro-reflectance from a rocket plume, the hemispherical collection cavity, diffuse detector and specular detector were all removed from the system so that the laser could illuminate the rocket plume directly. The laser focusing optics were also removed from the system so that the laser was well collimated where it intersected the plume. Since the measurement of an actual rocket plume would have been rather costly, a solid model rocket engine was purchased and mounted to a test stand. The solid rocket was manufactured by Aerotech, Inc. of Las Vegas, NV. A reloadable casing was used with the solid rocket model number F22-7J single stage which had 46 grams (1.63 oz.) of propellant delivering a total impulse of 65 N-seconds (14.6 lb-sec) and an average thrust of 22 N (4.9 lbs.). Four engines were fired, each lasting for just over 3 seconds. The laser modulation and detection frequency were driven by the signal generator which was set at 20 Hz.

The first engine was successfully fired in order to verify the test stand operation. The laser was fired at the rocket plume for the second and fourth rocket firings, but was turned off for the third rocket firing in order to determine if there was any signal from the rocket plume itself. The modulation/detection frequency was chosen in order to remain outside of the anticipated band of frequencies produced by the rocket plume which was thought to be rather high. Despite this, a signal was present from the plume even at 20 Hz. The fourth firing was slightly different from the second in that a filter was used to reject any energy outside the spectral band of the laser in an attempt to minimize the signal from the plume. Table 4 summarizes the four firings. The spectral response of the system with the filter is shown in Fig. 8.

The data obtained during these tests suggests that the measurement of a rocket plume retro-reflectance is possible, but the highly variant nature of the signal, as well as the background, require an instrument specifically designed for such a measurement. Particular attention needs to be given to the spectral transmission of the laser filter, in order to block out the background signal. The spot size of the laser on the rocket plume should also be considered. A larger spot size could possibly help suppress, or average out the spatial variance of the signal and/or background. One more possibility includes sweeping the modulation frequency of the laser. This may have several advantages. First, areas of low background noise may be identified in this manner. Second, the retro-reflectance of the plume should be the same regardless of the laser modulation frequency so that some data averaging could possibly be done.

4.0 CONCLUDING REMARKS

A novel method for measuring the scatter properties with respect to angle of incidence has been demonstrated. This technology will enable the design and manufacture of a portable benchtop, laboratory FTIR spectrometer capable of measuring scatter properties versus wavelength as well as a small, rugged, hand-held portable instrument capable of measuring scatter properties at a single wavelength. Both instruments will be capable of sample measurements at various angles of incidence. A design study shows an FTIR can be packaged with the ellipsoidal cavity to produce a much needed and highly precise instrument for scientific use.

The scanning FTIR spectrometer instrument, would allow TIS and Retro-Reflectance measurements as a function of wavelength in order to investigate spectrally interesting areas in hardbody signatures, thermal control coatings, and other industries. The technology can be easily adapted for true, hand-held laboratory/portable measurements, thus helping to spread the use of TIS measurements in the optics industry where it has long been fairly inaccessible due to the lack of commercial instrumentation and the cost of performing the measurement.

The measurement performance of the SMART-TIS instrument breadboard shows that the instrument is capable of making precise, repeatable measurements of surface scatter properties. The utility and flexibility of the instrument has also been demonstrated in measuring the Lambertian properties of a surface as well as performing the hemispherical reflectance measurements. The rocket plume study shows the need for an instrument to be designed solely for the purpose of performing the measurement of rocket plumes.

Phase I of the Total Integrated Scatter and Retro-Reflectance Portable Instrument Program has met or exceeded all the goals and expectations set forth from beginning to end. A novel approach to making TIS and Retro-Reflectance measurements has been demonstrated and proven to be highly accurate and repeatable.

5.0 References

1. Bennett, Jean M. and Mattson, Lars. *Introduction to Surface Roughness and Scattering*. Optical Society of America, Washington, D.C., 1989.

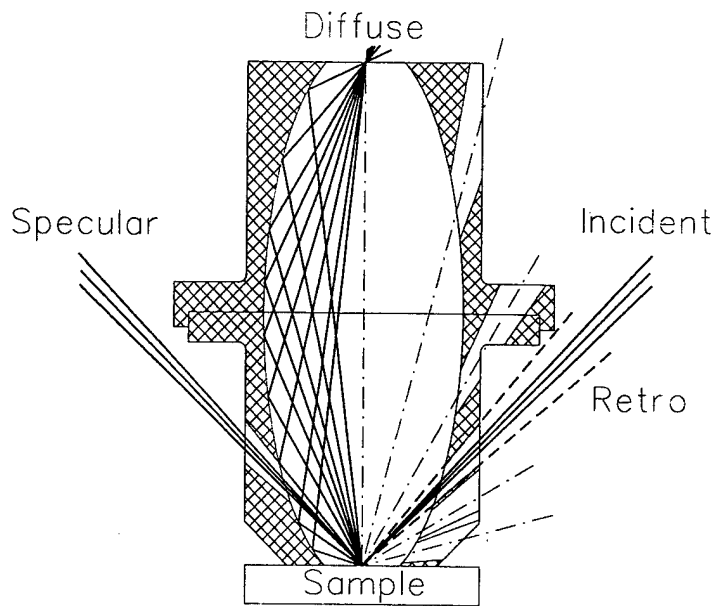

Figure 1. Hemispherical Collection Cavity.

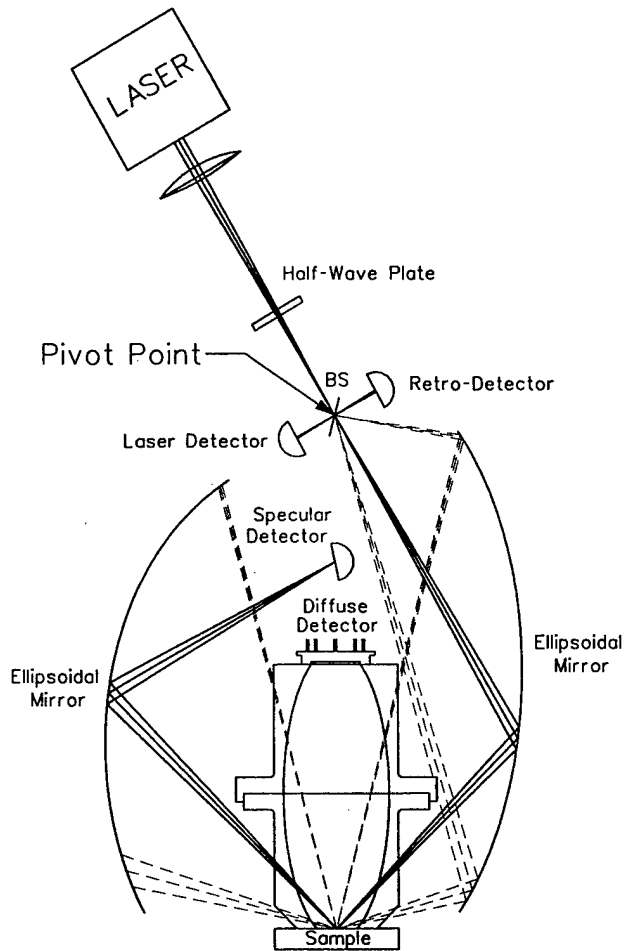

Figure 2. SMART-TIS Concept.

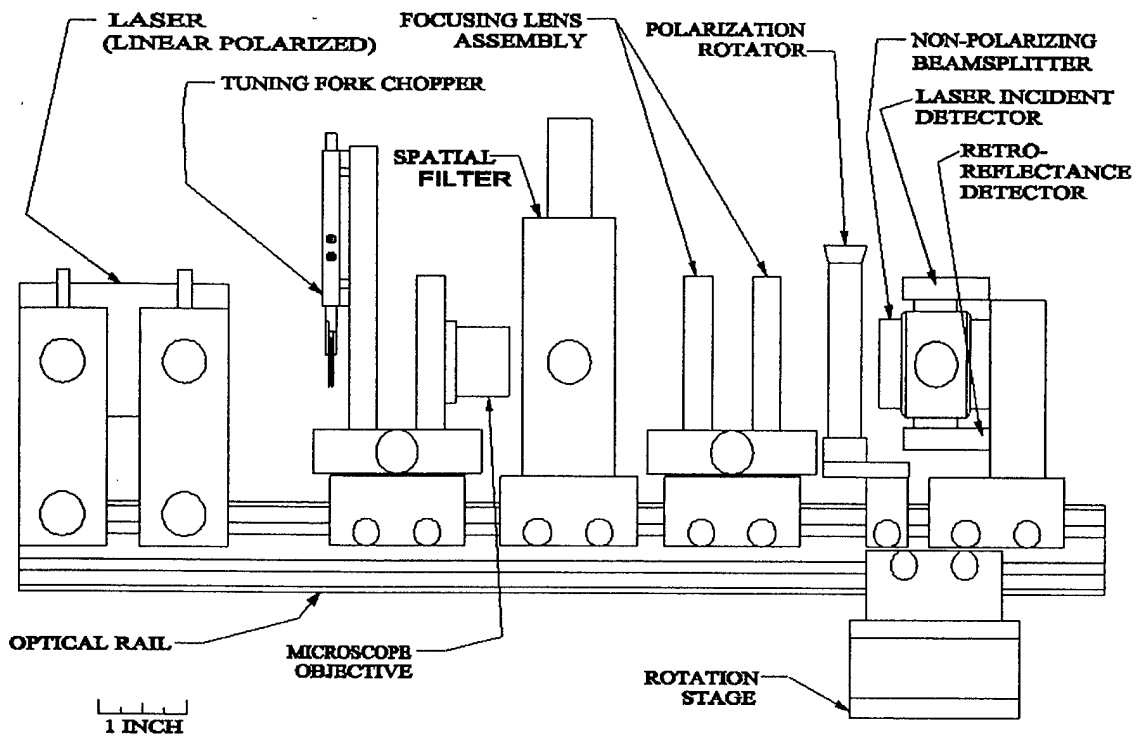

Figure 3. Laser Section.

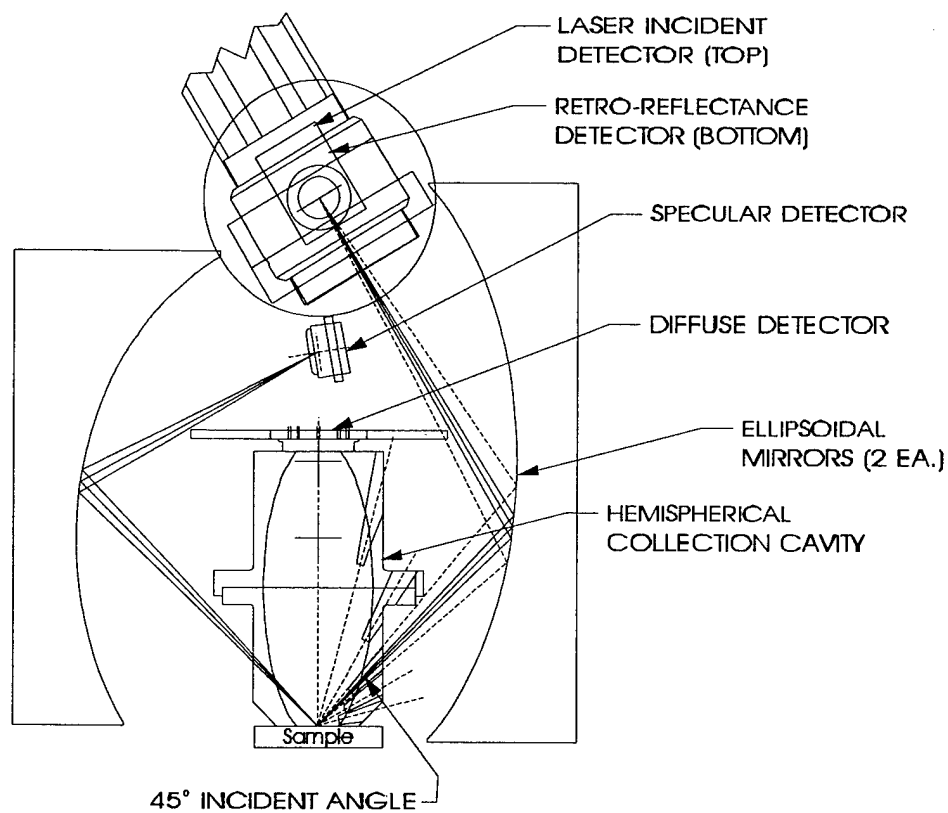

Figure 4. Measurement Section.

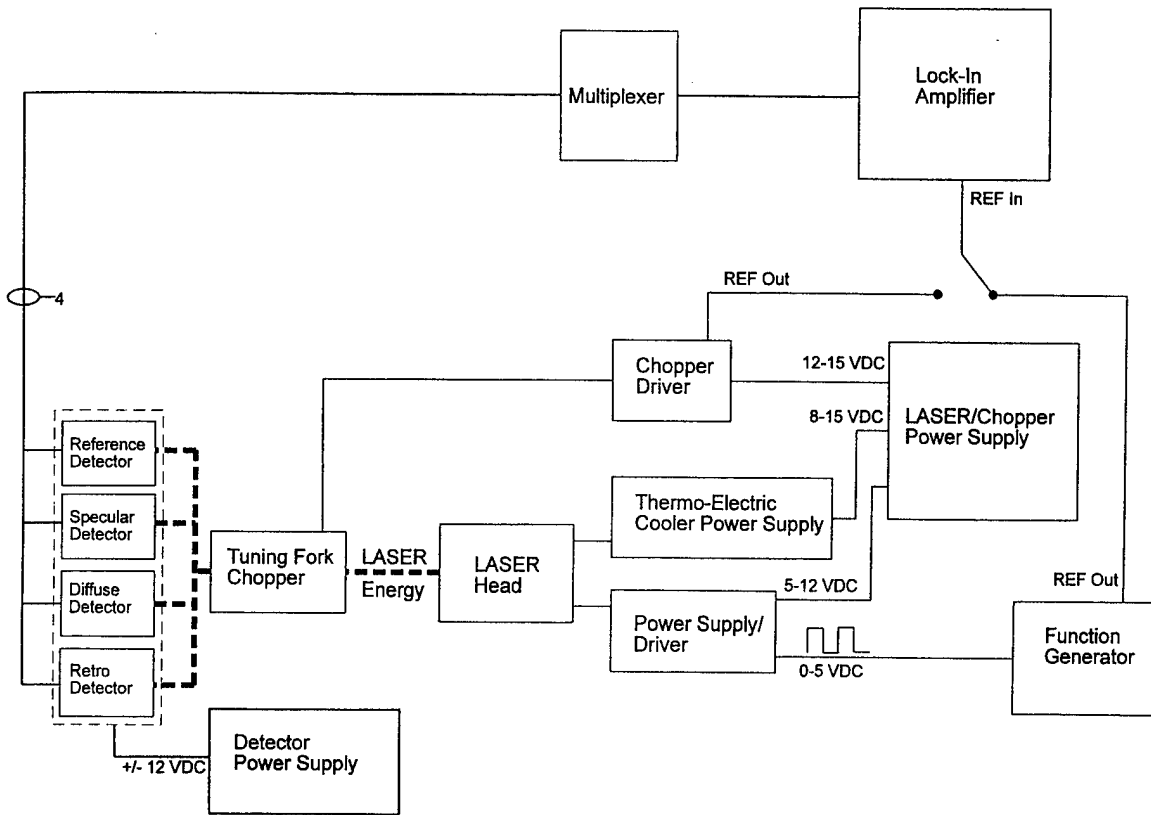

Figure 5. Electrical/Electronic Block Diagram.

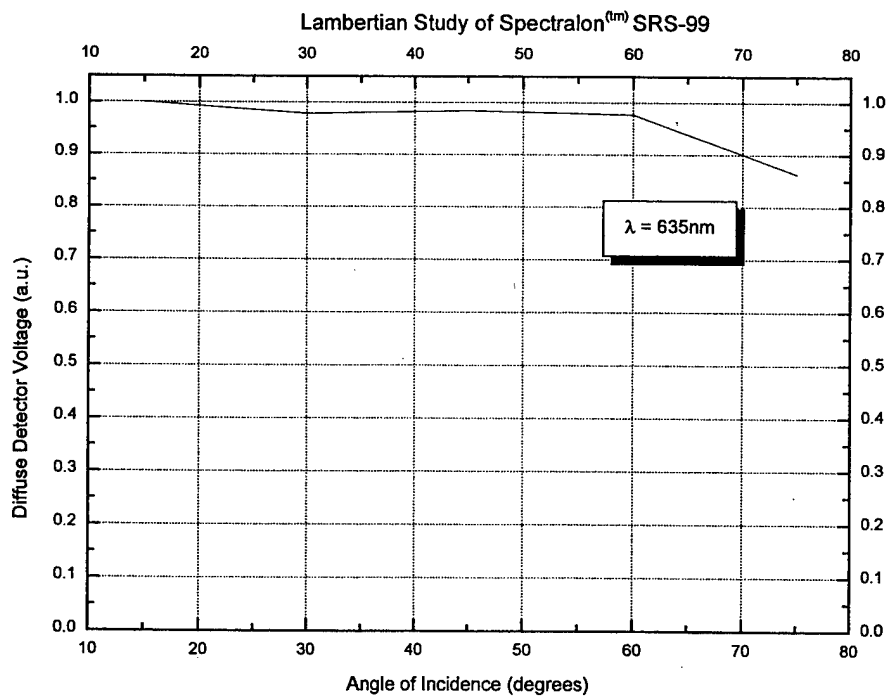

Figure 6. Lambertian Study of SpectralonTM SRS-99.

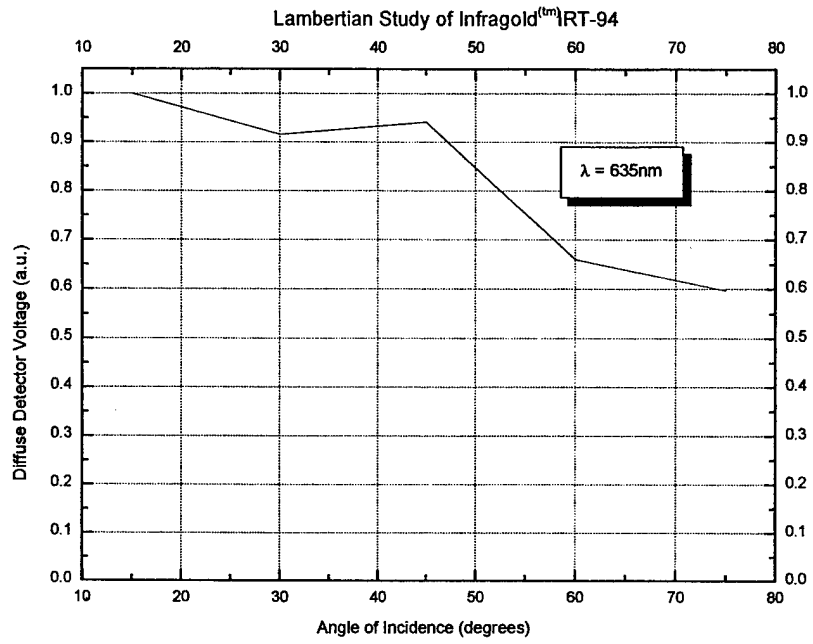

Figure 7. Lambertian Study of Infragold[™] IRT-94.

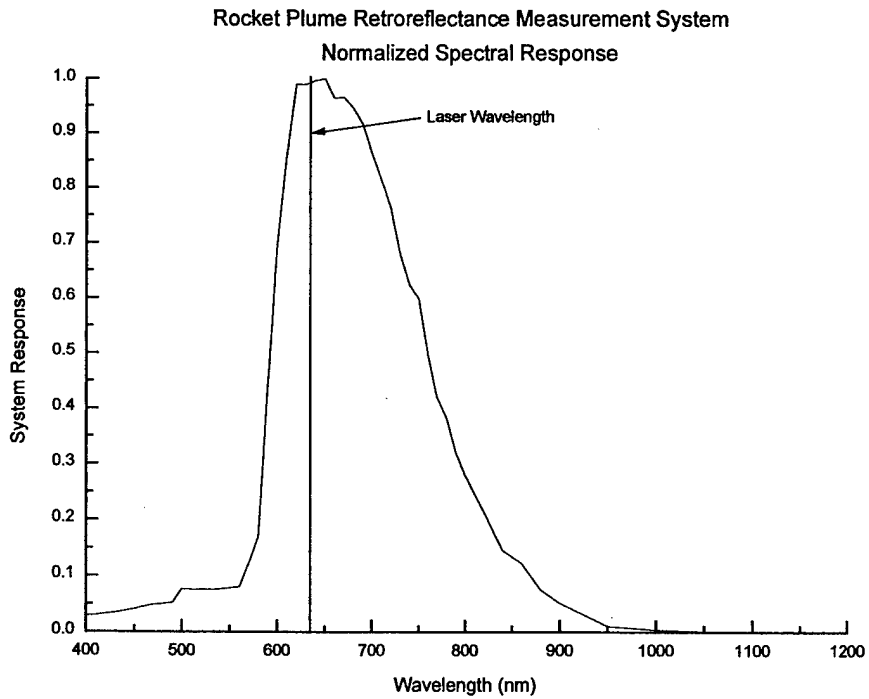

Figure 8. System Spectral Response.

Sample	Comments	SMART-TIS	UAH	% Error	Date Measured	% Change
Newport 1	Slightly dusty, good condition	20.4Å	21Å	-1.4%	11/1/97	-
Newport 1	Stored on clean bench	20.4Å	21Å	-1.4%	11/4/97	0%

Table 1. RMS Surface Roughness Measurement Comparison.

Sample	Description	Percent Retro-Reflection
Spectralon SRS-99	Near-Lambertian Scattering Surface	0.06%
Aluminum Block	Single-Direction Sanded Surface	0.50%
Brass Shim Stock	Directionally Aligned Machine Marks	0.06%
3M Post-It Notes	Notepad, 1/4" Thick	0.08%
Aluminum Foil	Shiny Side, Aligned for Maximum	0.20%

Table 2. Retro-Reflectance of Commonly Available Materials.

Sample Name	Diffuse	Specular	SMART-TIS	LPSR
Black Anodize	0.05	0	0.05	0.05
S.A. Anodize	0.65	0.03	0.68	0.68
Indium	0.46	0.13	0.59	0.59
Diffuse Black	0.02	0	0.02	0.02
Diffuse White	0.94	0	0.94	0.94
Nickel	0.41	0.02	0.43	0.44
Spec Cal Mirror	0	0.95	0.95	0.95
Sand-Blasted Al	0.57	0.01	0.58	0.57

Table 3. Near-Normal Hemispherical Reflectance Measurement Comparison.

Firing	Laser	Measurement
1	OFF	None: Verify Test Stand Operation
2	ON	Plume Retroreflectance and Intrinsic Plume Signature
3	OFF	Intrinsic Plume Signature
4	ON	Plume Retroreflectance and Intrinsic Plume Signature (spectral filter)

Table 4. Solid Model Rocket Test Firing Summary.