

AD_____

AWARD NUMBER DAMD17-98-1-8233

TITLE: Mammary Specific Expression of CRE Recombinase Under the Control of an Endogenous MMTV LTR: A Conditional Knock-Out System

PRINCIPAL INVESTIGATOR: Reb J. Russell, II., Ph.D.

CONTRACTING ORGANIZATION: University of Pennsylvania
Philadelphia, Pennsylvania 19104-3246

REPORT DATE: February 1999

TYPE OF REPORT: Annual Summary

PREPARED FOR: U.S. Army Medical Research and Materiel Command
Fort Detrick, Maryland 21702-5012

DISTRIBUTION STATEMENT: Approved for public release;
distribution unlimited

The views, opinions and/or findings contained in this report are those of the author(s) and should not be construed as an official Department of the Army position, policy or decision unless so designated by other documentation.

REPORT DOCUMENTATION PAGE

Form Approved
OMB No. 0704-0188

Public reporting burden for this collection of information is estimated to average 1 hour per response, including the time for reviewing instructions, searching existing data sources, gathering and maintaining the data needed, and completing and reviewing the collection of information. Send comments regarding this burden estimate or any other aspect of this collection of information, including suggestions for reducing this burden, to Washington Headquarters Services, Directorate for Information Operations and Reports, 1215 Jefferson Davis Highway, Suite 1204, Arlington, VA 22202-4302, and to the Office of Management and Budget, Paperwork Reduction Project (0704-0188), Washington, DC 20503.

1. AGENCY USE ONLY <i>(Leave blank)</i>	2. REPORT DATE February 1999	3. REPORT TYPE AND DATES COVERED Annual Summary (1 Apr 98 - 31 Jan 99)	
4. TITLE AND SUBTITLE Mammary Specific Expression of CRE Recombinase Under the Control of an Endogenous MMTC LTR: A Conditional Knock-out System		5. FUNDING NUMBERS DAMD17-98-1-8233	
6. AUTHOR(S) Reb J. Russell, II., Ph.D.			
7. PERFORMING ORGANIZATION NAME(S) AND ADDRESS(ES) University of Pennsylvania Philadelphia, Pennsylvania 19104-3246		8. PERFORMING ORGANIZATION REPORT NUMBER	
9. SPONSORING / MONITORING AGENCY NAME(S) AND ADDRESS(ES) U.S. Army Medical Research and Materiel Command Fort Detrick, Maryland 21702-5012		10. SPONSORING / MONITORING AGENCY REPORT NUMBER	
11. SUPPLEMENTARY NOTES		19990820 032	
12a. DISTRIBUTION / AVAILABILITY STATEMENT Approved for public release; distribution unlimited		12b. DISTRIBUTION CODE	
13. ABSTRACT <i>(Maximum 200 words)</i>			
14. SUBJECT TERMS breast cancer		15. NUMBER OF PAGES 7	
		16. PRICE CODE	
17. SECURITY CLASSIFICATION OF REPORT Unclassified	18. SECURITY CLASSIFICATION OF THIS PAGE Unclassified	19. SECURITY CLASSIFICATION OF ABSTRACT Unclassified	20. LIMITATION OF ABSTRACT Unlimited

FOREWORD

Opinions, interpretations, conclusions and recommendations are those of the author and are not necessarily endorsed by the U.S. Army.

____ Where copyrighted material is quoted, permission has been obtained to use such material.

____ Where material from documents designated for limited distribution is quoted, permission has been obtained to use the material.

____ Citations of commercial organizations and trade names in this report do not constitute an official Department of Army endorsement or approval of the products or services of these organizations.

 In conducting research using animals, the investigator(s) adhered to the "Guide for the Care and Use of Laboratory Animals," prepared by the Committee on Care and use of Laboratory Animals of the Institute of Laboratory Resources, national Research Council (NIH Publication No. 86-23, Revised 1985).

____ For the protection of human subjects, the investigator(s) adhered to policies of applicable Federal Law 45 CFR 46.

____ In conducting research utilizing recombinant DNA technology, the investigator(s) adhered to current guidelines promulgated by the National Institutes of Health.

____ In the conduct of research utilizing recombinant DNA, the investigator(s) adhered to the NIH Guidelines for Research Involving Recombinant DNA Molecules.

____ In the conduct of research involving hazardous organisms, the investigator(s) adhered to the CDC-NIH Guide for Biosafety in Microbiological and Biomedical Laboratories.

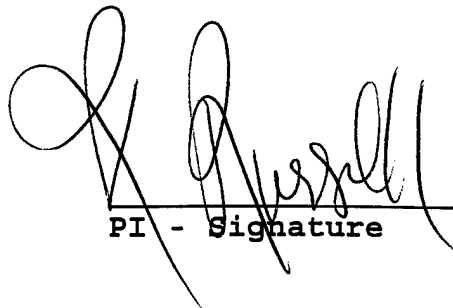

PI - Signature

Date

TABLE OF CONTENTS

Front Cover

SF 298 (Report Documentation Page)

Foreword

Table of Contents

Introduction 2

Vector Construction 2

Animal Production 3

Obtaining External Reagents 4

Conclusions 4

Introduction

The project to test expression of Cre recombinase directed by the *Mtv-17* locus is in its first year of three years of funding. The hypothesis of the project was to develop a novel and useful breast cancer model using the tissue specific expression of the *Mtv-17* locus, which has previously been shown to express only in the mammary gland. We proposed to ‘knocking-in’ Cre recombinase at the *Mtv-17* env region and this should result in expression of this enzyme only in the mammary gland. Mice that carry the *Mtv-17* Cre fusion vector will be mated to lox P p53 conditional knock-out mice, resulting in loss of functional p53 in the mammary gland only. These animals should only develop mammary tumors and not other tumors. Our knock-in vector will provide a conditional knock-out system and locus for mammary gland specific expression of many different transgenes and should be of widespread utility to the study of both transformation and development of this tissue.

At this time, the progress of the project can be divided into three parts. The first part is vector construction. The second part is production of animals. The third portion is the obtaining of certain reagents.

Vector Construction

Three vectors were described in the proposal. All three vectors are knock-in vectors. These vectors by definition are designed to place either a gene or sequence in a specific locus by homologous recombination in embryonic stem cells.

The first vector has been constructed to ‘knock-in’ Cre recombinase into the *Mtv-17* locus at the env position (figure 1). This is accomplished through vector design which mutates the endogenous ATG start site of env followed by the ATG start site of Cre recombinase. The second vector is similar to the first. It is also designed to homologously recombine with the *Mtv-17* locus (figure). However, in the second vector Cre recombinase is placed in the gag position and the ATG start site of gag is removed in the construct. Both of these vectors have been constructed and have been used to transform embryonic stem (ES) cells.

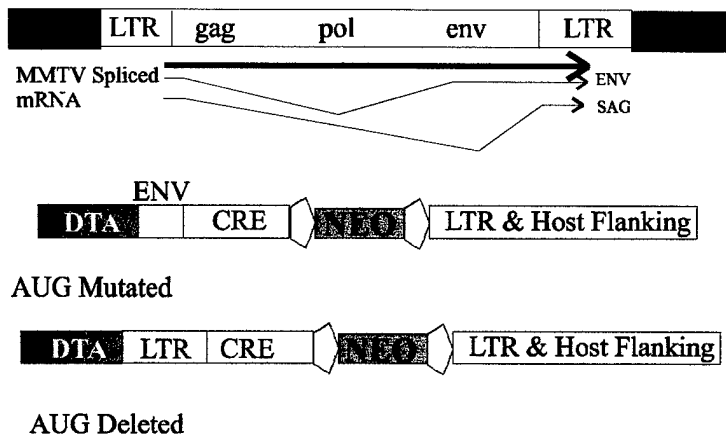

Figure 1: The two knock-in constructs which express Cre Recombinase under the direction of the *Mtv-17* locus. The top figure is the endogenous locus and the mRNA which is synthesized from that locus. The second figure is the vector which is designed to homologously recombine with env position of the locus. The bottom panel is the second vector which is designed to homologously recombine with the gag position of *Mtv-17* locus. Long Terminal Repeats (LTR), Cre Recombinase (CRE), Neomycin resistance (NEO), Diphtheria Toxin A (DTA).

The third and final vector is designed to undergo homologous recombination with the p53 locus (figure 2). Rather than knocking-in a gene such as Cre recombinase. This vector has been designed to embed lox P sites into introns four and six. The result is the production of normal p53 protein in all cells except those that express Cre recombinase. In cells that express Cre recombinase, a mutant protein will be formed which retains the tetramerization domain but lacks a DNA binding domain. This protein is predicted to be a dominant mutant. Even an animal heterozygous for the mutant p53 should have an elevated rate of cancer. The p53 knock-in vector is two steps from being finished at this time.

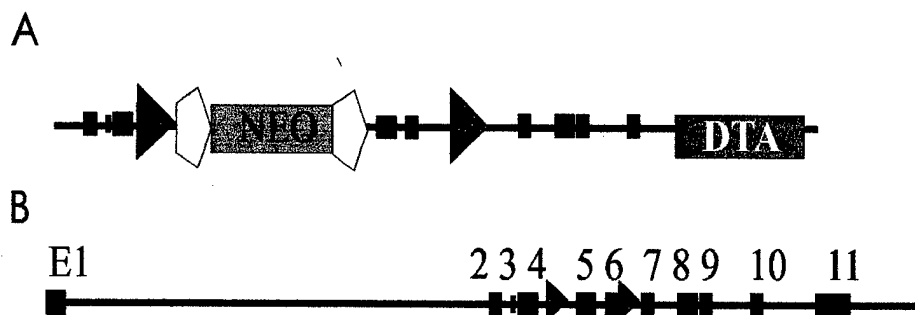

Figure 2: The p53 knock-in vector (panel A) and endogenous p53 locus following homologous recombination (panel B). The lox p sites represented by the triangles are embed in the introns, represented by the solid lines and the exons are represented by the solid boxes. (See figure 1 for abbreviations).

Animal Production

The first two targeting vectors, which knock-in Cre recombinase, have been transfected into the C57/Bl6 embryonic stem cells. To date, 197 neomycin (neo) positive colonies have been obtained using the first knock-in vector (figure 1). It is designed to place Cre in the env position of the *Mtv-17* locus. These neo colonies were then screened by a polymerase chain reaction using primers directed against the portion of the envelope that is only in the endogenous *Mtv* loci and not in the knock-in vector. The other primer is located in Cre recombinase which is only in the targeting vector. The only way that the desired 1.5 Kb product of this PCR can be obtained is if homologous recombination at an *Mtv* locus has occurred. The PCR screen is only preliminary since a positive 1.5 Kb product could also be obtained from recombination of vector with either of two other endogenous *Mtv* loci present in the C57/Bl6 genetic background. However, this is less likely due to the large amount of host flanking region which should primarily if not exclusively direct the vector into the *Mtv-17* position.

Four of the 197 clones produced a 1.5 Kb fragment. These clone will be expanded and tested using by southern analysis for confirmation of the correct locus. The four clones represent a possible homologous recombination to the correct locus but in no way should be considered correct until the southern analysis can be performed.

The second knock-in vector is designed to place Cre in the gag position of the *Mtv-17* locus. Transfection into ES cells has produced 94 neo positive colonies. These colonies can not easily be screened by PCR. Rather, these colonies have been unsuccessfully been screened by southern blot analysis of the genomic DNA of the embryonic stem cells. More colonies will need to generated and tested.

The two male lox P B-gal reporter mice (a kind gift of David Anderson, Ph.D. California Institute of

Technology) were obtained. After a period of quarantine, these mice were bred to C57/Bl6 females to generate a F2 generation. The F2 animals were tested by PCR analysis for the presence of the B-gal gene and as expected all animals in the F2 generation possessed the construct. The heterozygous F2 females were bred with the F1 homozygous males to generate a F3 generation. By Mendelian genetics, 50% of the F3 offspring should be homozygous for the reporter transgene. The easiest way to test the genotype of these animals with respect to the transgene is to test by breeding. The F3 generation, once it reaches sexual maturity, will be bred to animals that are nullizygous for the transgene. The resulting offspring will be genotyped by PCR analysis. The genotype of the offspring will allow us to determine the F3 generation genotype and homozygous animals can be crossed to generate a homozygous colony.

Obtaining External Reagents

The Balb/c genomic p53 construct was a kind gift of Lawrence Donehower, Ph.D. This was used in the production of the p53 knock-in vector. The lox P reporter mice were a kind gift of David Anderson, Ph.D. These mice will be used to test the tissue specific expression of Cre Recombinase under the direction of the *Mtv-17* locus. A Cre Recombinase expressing adenovirus was a kind gift of Frank Graham, Ph.D. The adenoviral infection of lox P mice will reveal any limitations if any of the reporter mice have in expression of β -galactosidase. The leukemia inhibitory factor (LIF) expressing CHO cells were a kind gift of the Genetics Research Institute, Cambridge, MA. The C57/ Bl6 mouse embryonic stem cells were a kind of Collin Stewart, Ph.D.

Conclusions

In summary, we have produced two of the three homologous recombination vectors proposed for the project. The third vector is nearly complete. Embryonic stem cell production is continuing with four potentially positive clones being obtained for one of the constructs. All of the reagents, which we proposed obtaining from outside sources, have been obtained. In general, the research has progressed according to the original statement of work with a slight lag in the production of the p53 vector. However, this vector is not necessary until later in the project since tissue specific expression of Cre recombinase must first be ascertained before breeding to p53 conditional knock-out mice can be done.

As I have already informed the Army, I will be leaving this project and the University of Pennsylvania to take a research and development position in industry at the end of January 1999. I strongly recommend that this project be continued in Professor Susan Ross' Laboratory with Jennifer Czarneski, Ph.D. as principal investigator. This project has great potential and has progressed according to the statement of work with all the necessary reagent to complete this project having been obtained. It is my sincere hope that the US Army Breast Cancer Research Program in its wisdom will see the benefits in continuing to fund the last two years of this project in my absence.