

Poynting's Theorems and Their Relationship to Antenna Power, Q, and Bandwidth

by

D. J. White

and

P. L. Overfelt

Research Department

JUNE 1999

NAVAL AIR WARFARE CENTER WEAPONS DIVISION
CHINA LAKE, CA 93555-6100



Approved for public release; distribution is
unlimited.

19990823 052

Naval Air Warfare Center Weapons Division

FOREWORD

This report documents work carried out and completed during fiscal year 1998 under an Office of Naval Research program funding document number N0001498WX20506, 6.1 funding. This research resulted in a better understanding of the fundamental limitations in antenna Q and bandwidth for electrically small antennas.

This report was reviewed for technical accuracy by Donald R. Bowling.

Approved by
JOHN W. FISCHER, *Head*
Research Department
30 April 1999

Under authority of
CHARLES H. JOHNSTON, JR
CAPT, U.S. Navy
Commander

Released for publication by
KAREN HIGGINS
Director for Research and Engineering

NAWCWPNS Technical Publication 8419

Published by Technical Information Division
Collation Cover, 43 leaves
First printing 60 copies

REPORT DOCUMENTATION PAGE

Form Approved
OMB No. 0704-0188

Public reporting burden for this collection of information is estimated to average 1 hour per response, including the time for reviewing instructions, searching existing data sources, gathering and maintaining the data needed, and completing and reviewing the collection of information. Send comments regarding this burden estimate or any other aspect of this collection of information, including suggestions for reducing this burden, to Washington Headquarters Services, Directorate for Information Operations and Reports, 1215 Jefferson Davis Highway, Suite 1204, Arlington, VA 22202-4302, and to the Office of Management and Budget, Paperwork Reduction Project (0704-0188), Washington, DC 20503.

1. AGENCY USE ONLY (Leave blank)		2. REPORT DATE June 1999	3. REPORT TYPE AND DATES COVERED Final, FY97-98	
4. TITLE AND SUBTITLE POYNTING'S THEOREMS AND THEIR RELATIONSHIP TO ANTENNA POWER, Q, AND BANDWIDTH (U)			5. FUNDING NUMBERS N0001498WX20546	
6. AUTHOR(S) D. J. White and P. L. Overfelt				
7. PERFORMING ORGANIZATION NAME(S) AND ADDRESS(ES) Naval Air Warfare Center Weapons Division China Lake, CA 93555-6100			8. PERFORMING ORGANIZATION REPORT NUMBER NAWCWPNS TP 8419	
9. SPONSORING/MONITORING AGENCY NAME(S) AND ADDRESS(ES) Dr. William Stachnik ONR Code 313 800 N. Quincy Arlington VA 22217-5660			10. SPONSORING/MONITORING AGENCY REPORT NUMBER	
11. SUPPLEMENTARY NOTES				
12A. DISTRIBUTION/AVAILABILITY STATEMENT A Statement; public release; distribution unlimited.			12B. DISTRIBUTION CODE	
13. ABSTRACT (Maximum 200 words) (U) In this report a number of the basic ideas and assumptions involved in the analysis of electrically small antennas is considered. Poynting's theorems in both the time and frequency domain cases are derived, and the conditions under which they are mathematically applicable are examined. Their relationships with stored energy, both time dependent and time average, are derived. Resistive and reactive power flow into circuits is examined and compared with the power flow across a closed surface surrounding an antenna. It is found that while using this approach to find the input or radiation resistance of a single port antenna can be justified, using the same approach to obtain the antenna input reactance cannot be justified. The antenna quality factor (Q) concept is considered from first principles, various forms of Q are explored for series and parallel circuits, and the relationship of the Q to the antenna bandwidth is discussed. A consistent theoretical foundation and a physical understanding of the radiation and stored energy properties of general antennas are constructed to determine the performance limits on electrically small antennas.				
14. SUBJECT TERMS Electrically small antennas, Poynting's theorems, reactive power, resistive power, antenna quality factor, bandwidth			15. NUMBER OF PAGES 86	
			16. PRICE CODE	
17. SECURITY CLASSIFICATION OF REPORT UNCLASSIFIED	18. SECURITY CLASSIFICATION OF THIS PAGE UNCLASSIFIED	19. SECURITY CLASSIFICATION OF ABSTRACT UNCLASSIFIED	20. LIMITATION OF ABSTRACT UL	

UNCLASSIFIED

SECURITY CLASSIFICATION OF THIS PAGE (When Data Entered)

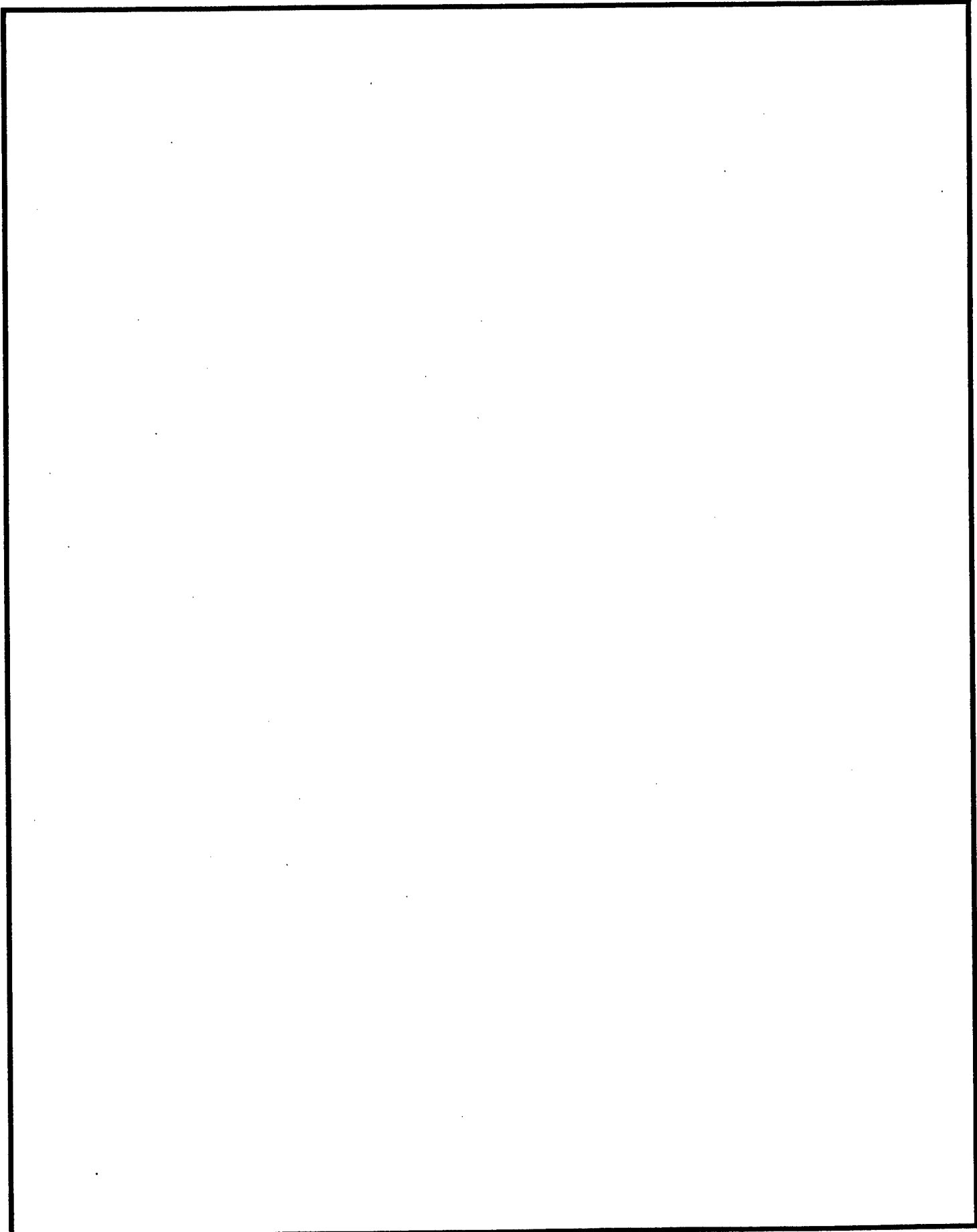

CONTENTS

Introduction	3
The Complex Poynting's Theorem (Time Harmonic Case)	4
Time Dependent Poynting's Theorem (General Case)	13
Summary and Discussion of Poynting's Theorems	16
Resistive and Reactive Power Flow and Equivalent Circuits	20
Power Flow and Poynting's Vector	27
Antenna Q and Bandwidth	34
Conclusion	53
References	54
Appendices	
A. The "Exact" Dipole Antenna and its Tangential Boundary Condition	57
B. Alternate Forms of the Circuit Power Flow Equation	65
C. The Relations Between the Field Components in Straight and Retarded Time	75
D. Effect on Q of Adding Purely Reactive Elements to Any Circuit	77
E. Equivalent Current and Voltage Generators	83
Figures:	
1. Complex Surface of Integration for the Complex Poynting Theorem With Actual Antenna Excluded	8
2. Complex Surface of Integration for the Complex Poynting Theorem With Actual Antenna Included	10
3. Series RLC Circuit With Applied Voltage, V	20
4. Parallel RLC Circuit With Applied Voltage, V	25
5. A Capacitively Loaded Dipole	34
6. A Typical Stored Energy as a Function of Time Plot	42
7. Using a Parallel Inductance as a Matching Element for a Hypothetical Series R C Antenna	49
8(a). Series RLC Circuit With Signal Source Shown as a Voltage Generator in Series With Impedance, Z_0	51
8(b). Parallel RLC Circuit With Signal Source Shown as a Voltage Generator in Series With Impedance, Z_0	50
A-1. Wire Dipole Antenna	57
A-2. Model for Dipole Antenna	58
A-3. Plot of F (Which is Proportional to the Magnitude of E_z Squared) Versus f	62
E-1. Voltage Generator	83
E-2. Current Generator	83
E-3. The Correct Current Generator to Deliver the Identical Current to the Load as the Voltage Generator $V_0 \cos \omega t$	86

INTRODUCTION

The use of physically small antennas and antenna arrays can produce large benefits, particularly considering the limited space available on missiles, satellites, and aircraft. Unfortunately, if the desired operating frequency is low, physically small also means electrically small. For example, if the operating frequency is around 500 MHz, the wavelength is 0.6 m, 60 cm, or approximately two feet. On a four-inch diameter missile it is clear that the largest antenna dimension available is liable to be only a fraction of a wavelength, i.e. electrically small. A little reading of antenna books and literature devoted to antenna theory and practice will soon lead to the conclusion that electrically small antennas present severe problems in terms of efficiency, operating bandwidth, beam-width, antenna patterns, gain and directivity. Experimental work will quickly reinforce these conclusions. Nonetheless, the possible variations in antenna and antenna array design appear infinite, so one can always hope to come up with the magical efficient, highly directive, wide bandpass (if that is what is desired) antenna that somehow "beats the game."

This need to use electrically small antennas and the problems of implementation have led to a long continuing effort on finding the theoretical limits on small antenna performance (References 1 through 11). That this work has continued for so long is, perhaps, due to the large payoff that could be obtained with at least acceptable electrically small antennas, and some doubt and confusion as to the universal validity of the preceding theoretical results. Indeed, Grimes (References 12 through 24) appears to claim that Q and bandwidth restrictions, arrived at by Wheeler (Reference 2), Chu (Reference 1), Harrington (Reference 3) and others, are much too restrictive and apply only to certain simple antennas. He asserts that much better performance can be obtained by using antennas consisting of the proper combination of electric and magnetic multipoles.

It is not the purpose of this report to determine, once and for all, what are the performance limits of electrically small antennas. It is rather to lay a solid theoretical foundation and physical understanding of the radiation and stored energy properties of antennas needed to find these theoretical limits. This foundation is badly needed because, while the papers quoted generally deal in some fairly involved mathematics to prove the particular points of the particular papers, they are not only difficult for the reader to follow, but all suffer from some lack of careful interpretation of the meanings of Poynting's theorem, equivalent circuits, and Q. For this purpose a careful derivation of Poynting's theorem for both the frequency domain [$\exp(j\omega t)$] and the time domain [$\cos(\omega t + \phi)$] forms for the electromagnetic fields is initiated in the next section.

THE COMPLEX POYNTING'S THEOREM (TIME HARMONIC CASE)

Technical books and papers on electromagnetic theory, at least in modern times, generally assume electromagnetic fields of the form

$$\bar{\mathbf{E}} = \bar{\mathbf{E}}_0 \exp(j\omega t) \quad (1a)$$

$$\bar{\mathbf{H}} = \bar{\mathbf{H}}_0 \exp(j\omega t) \quad (1b)$$

where $\bar{\mathbf{E}}_0$ and $\bar{\mathbf{H}}_0$ are complex vectors.

However, such complex fields have no physical existence—it could be said that "Mother Nature," only knows/contains real numbers, not complex or imaginary. Often electromagnetic texts (References 25 through 36) will note that the use of complex fields is merely a mathematical convenience and that the actual fields are of $\sin \omega t$ or $\cos \omega t$ form, and what is meant or understood is actually the real parts of Equations 1a and b.

Breaking $\bar{\mathbf{E}}_0$ and $\bar{\mathbf{H}}_0$ into real and imaginary parts,

$$\bar{\mathbf{E}}_0 = \bar{\mathbf{E}}_0' - j\bar{\mathbf{E}}_0'' \quad (2a)$$

$$\bar{\mathbf{H}}_0 = \bar{\mathbf{H}}_0' - j\bar{\mathbf{H}}_0'' \quad (2b)$$

it is simple to show that

$$\bar{\mathcal{E}} = \text{Re } \bar{\mathbf{E}} = \bar{\mathbf{E}}_0' \cos \omega t + \bar{\mathbf{E}}_0'' \sin \omega t \quad (3a)$$

$$\bar{\mathcal{H}} = \text{Re } \bar{\mathbf{H}} = \bar{\mathbf{H}}_0' \cos \omega t + \bar{\mathbf{H}}_0'' \sin \omega t \quad (3b)$$

It should be noted that $\bar{\mathcal{E}}$ and $\bar{\mathcal{H}}$ are not physically realizable either, but only in the sense that they have neither beginning nor ending in time. Otherwise Equations 3a and b are perfectly general for sinusoidal time dependence of the fields.

For linear problems in electromagnetics, (i.e., problems in which the field quantities $\bar{\mathcal{E}}$ and $\bar{\mathcal{H}}$, or in circuit problems, current and voltage, appear only to the first power) it generally suffices, and is mathematically simpler, to use the complex or time harmonic form, work the problem, and, if necessary, take the real part upon completion.

For nonlinear problems, however, this procedure will lead to erroneous results. For example, suppose there is a device whose output is proportional to voltage squared, i.e.,

$$L = KV^2 .$$

If the form $V = V_0 \exp(j\omega t)$ is used, then

$$L = KV_0^2 \exp(j2\omega t)$$

and if the real part is taken, $L = KV_0^2 \cos 2\omega t$.

On the other hand, if the $V = V_0 \cos \omega t$ form is used,

$$V^2 = V_0^2 \cos^2 \omega t = V_0^2 (1 + \cos 2\omega t) / 2$$

so that

$$L = KV_0^2 (1 + \cos 2\omega t) / 2 ,$$

which is clearly not equal to the first result.

Much of the work previously referenced is based, at least in part, on the Poynting vector and Poynting's theorem. There are two forms of Poynting's vector in general use, the complex Poynting vector

$$\bar{S}_c = (\bar{E} \times \bar{H}^*) / 2 \tag{4a}$$

and the time domain Poynting vector

$$\bar{S} = \bar{E} \times \bar{H} . \tag{4b}$$

In antenna problems generally, \bar{H} is proportional to \bar{E} (and \bar{E} to \bar{H}) so it is clear that \bar{S}_c and \bar{S} are proportional to the fields squared and are, in that sense, nonlinear. It follows that \bar{S}_c should be used and interpreted with caution.

In most physics texts (Reference 25), the time domain Poynting vector is interpreted as the instantaneous intensity of energy flow at a point in an arbitrary electromagnetic

field, i.e., the energy per second crossing a unit area whose normal is oriented in the direction of the vector, $\bar{\mathcal{E}} \times \bar{\mathcal{H}}$. Correspondingly, the real part of the complex Poynting vector is interpreted as the mean intensity of the energy flow in a harmonic electromagnetic field.

It is nonetheless true that most antenna texts (References 26 through 36) choose to work with \bar{S}_c , probably for the sake of mathematical simplicity. Doing this has led to some misinterpretation of Poynting's theorem and its application to antennas. However, to refresh the reader's memory, Poynting's theorem in complex form is derived first. (While this derivation can be found in many texts, the steps are important in understanding what Poynting's theorem does and does not say.)

A useful vector identity is

$$\nabla \cdot \bar{\mathcal{E}} \times \bar{\mathcal{H}}^* = \bar{\mathcal{H}}^* \cdot \nabla \times \bar{\mathcal{E}} - \bar{\mathcal{E}} \cdot \nabla \times \bar{\mathcal{H}}^* \quad (5)$$

Maxwell's equations for the time harmonic case are

$$\nabla \times \bar{\mathcal{E}} = -j\omega\mu\bar{\mathcal{H}} \quad (6a)$$

$$\nabla \times \bar{\mathcal{H}} = \bar{\mathcal{J}} + j\omega\epsilon\bar{\mathcal{E}} \quad (6b)$$

Substituting these into Equation 5 gives

$$\nabla \cdot \bar{\mathcal{E}} \times \bar{\mathcal{H}}^* = j\omega(\epsilon\bar{\mathcal{E}} \cdot \bar{\mathcal{E}}^* - \mu\bar{\mathcal{H}} \cdot \bar{\mathcal{H}}^*) - \bar{\mathcal{E}} \cdot \bar{\mathcal{J}}^* \quad (7)$$

Integrating both sides with respect to volume gives

$$\int_V \nabla \cdot \bar{\mathcal{E}} \times \bar{\mathcal{H}}^* dv = j\omega \int_V (\epsilon\bar{\mathcal{E}} \cdot \bar{\mathcal{E}}^* - \mu\bar{\mathcal{H}} \cdot \bar{\mathcal{H}}^*) dv - \int_V \bar{\mathcal{E}} \cdot \bar{\mathcal{J}}^* dv \quad (8)$$

Equation 8 is clearly a mathematical fact, given Maxwell's equations and the time harmonic form of the fields, even though that form is not physically realizable. It is pertinent, however, to ask, "Integrate over what volume?" The answer, of course, is any volume one may choose. It will usually be reasonable to choose a volume enclosing the antenna, although Equation 8 is still true even if this is not done. Usually it simplifies the algebra to use a coordinate system such that the antenna is located at the origin although that is a convenient, not a necessary choice. Coordinate systems and their location are the "inventions" of mankind, and one is free to dispose of them as wished although it is usually preferable to choose them such that can one at least do the algebra.

Any finite sized antenna, no matter how large physically must, by physical reasoning, look like a point source if the observer is far enough away. Thus spherical coordinates are the natural coordinates for most antenna problems, and a logical volume in most cases would be a sphere with the antenna at its center.

The next step is to apply the divergence theorem to Equation 8, ending up with Poynting's theorem for the time harmonic case, i.e.,

$$(1/2) \oint_A \bar{E} \times \bar{H}^* \cdot d\bar{a} = (j\omega/2) \int_V (\epsilon \bar{E} \cdot \bar{E}^* - \mu \bar{H} \cdot \bar{H}^*) dv - (1/2) \int_V \bar{E} \cdot \bar{J}^* dv \quad (9)$$

Equation 9 is essentially, a mathematical identity, given Maxwell's equations and the assumption of time harmonic fields. However, it is the "almost" any volume for the volume integration on the right-hand side that causes problems.

The solutions to Maxwell's equations in spherical coordinates are composed of products of spherical Hankel functions (actually of the first and second kinds), their derivatives, associated Legendre polynomials, their derivatives, and functions of ϕ in the forms of $\exp(jm\phi)$, $\cos m\phi$, and $\sin m\phi$. These are the spherical harmonic solutions (Reference 25).

Typically the antenna is considered as a point source at the origin (although it is clear that actual antennas must have finite extent) and often only spherical Hankel functions of the second kind are used, which are generally of the form (Reference 25)

$$\exp(-jkr) \sum_{n=1}^M a_n (1/kr)^n ,$$

whereas the first kind are of the form

$$\exp(jkr) \sum_{n=1}^M a_n^* (1/kr)^n ,$$

on the basis that radiation propagates only outward from the antenna as signified by $\exp(-jkr)$.

If the antenna is not at the origin or is considered to be finite in extent, spherical Bessel functions would have to be utilized as well, at least inside some sphere containing the antenna (Reference 35). Regardless, the spherical Hankel functions contain a singularity, and become infinite at $r=0$.

The divergence theorem only applies to volumes that contain no singular points (References 37 and 38). Thus the origin must be excluded from Equation 9 if the solution is to contain spherical Hankel functions. This can be done by excluding a small

sphere of radius a_i around the origin (any other non-spherical volume around the origin would presumably suffice but would no doubt greatly complicate the integration process).

Having excluded the origin, and hence the singular point (References 37 and 38), the surface integral on the left must be performed over the complete surface, where the origin is surrounded by an arbitrary inner sphere of radius a_i and an outer sphere of radius a_o which is as large as desired. To signify this, Equation 9 is rewritten as

$$\left[(1/2) \oint_A \bar{E} \times \bar{H}^* \cdot d\bar{a} \right]_{a_i, a_o} = (j\omega/2) \int_V (\epsilon \bar{E} \cdot \bar{E}^* - \mu \bar{H} \cdot \bar{H}^*) dv - (1/2) \int_V \bar{E} \cdot \bar{J}^* dv \quad (10)$$

where the subscripts a_i and a_o indicate that the integration must be over the complete surface including the inner sphere used to exclude the singular point at the origin (see Figure 1).

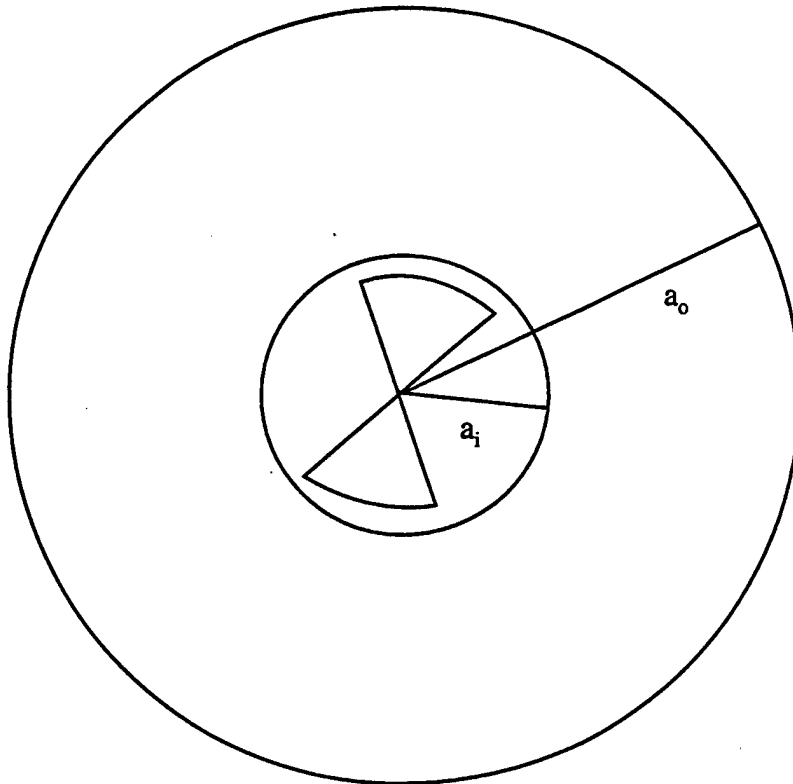

FIGURE 1. Complex Surface of Integration for the Complex Poynting Theorem With Actual Antenna Excluded.

There is no particular limit on the size of a_i . Frequently the current density \bar{J} at the antenna is not known and is difficult to solve for. Thus it is common practice to assume a current density or current on the antenna that is "reasonable," and work from there. An example is the assumed sinusoidal current distribution on a dipole antenna. For a half

example is the assumed sinusoidal current distribution on a dipole antenna. For a half wave dipole using this assumed current distribution, "exact" electromagnetic fields can be derived (Reference 39). It is shown in Appendix A that these "exact fields" cannot be correct in the sense that tangential \bar{E} does not go to zero at the antenna surface, as it should for a good conductor. Thus there is motive for making a_1 the radius of the smallest sphere that will just enclose the antenna. The volume between a_1 and a_0 then has $\bar{J} = 0$, and Equation 10 becomes

$$\left[(1/2) \int_A \bar{E} \times \bar{H}^* \cdot d\bar{a} \right]_{a_1, a_0} = (j\omega/2) \int_V (\epsilon \bar{E} \cdot \bar{E}^* - \mu \bar{H} \cdot \bar{H}^*) dv \quad (11)$$

in the outer region. This is the situation shown in Figure 1 and will be the case used generally in the remainder of this report.

Aside from the mathematical convenience of not having to deal with the volume integral over $\bar{E} \cdot \bar{J}^*$, there is another, perhaps more cogent reason to exclude the actual antenna where \bar{J} exists.

Consider Figure 2. In this case the integration includes the volume of the actual antenna, V_1 , where \bar{J} exists and the fields are given by \bar{E}_1 and \bar{H}_1 . Exterior to V_1 in the sphere of radius a_0 is the volume V_2 with the fields \bar{E}_2 and \bar{H}_2 . It is \bar{H}_2 and \bar{E}_2 that can be expressed in terms of the exterior spherical harmonics and thus have the singularity at $r = 0$. \bar{E}_1 , \bar{H}_1 , and \bar{J} need have no such singularity and physical argument can be made that since V_1 contains the actual antenna, no such singularity exists.

Equation 8 can now be written as

$$\int_{V_1} \nabla \cdot \bar{E}_1 \times \bar{H}_1^* dv + \int_{V_2} \nabla \cdot \bar{E}_2 \times \bar{H}_2^* dv = j\omega \int_{V_1} (\epsilon_1 \bar{E}_1 \cdot \bar{E}_1^* - \mu_1 \bar{H}_1 \cdot \bar{H}_1^*) dv$$

$$+ j\omega \int_{V_2} (\epsilon_0 \bar{E}_2 \cdot \bar{E}_2^* - \mu_0 \bar{H}_2 \cdot \bar{H}_2^*) dv - \int_{V_1} \bar{E}_1 \cdot \bar{J}^* dv$$

which is true without any particular qualification.

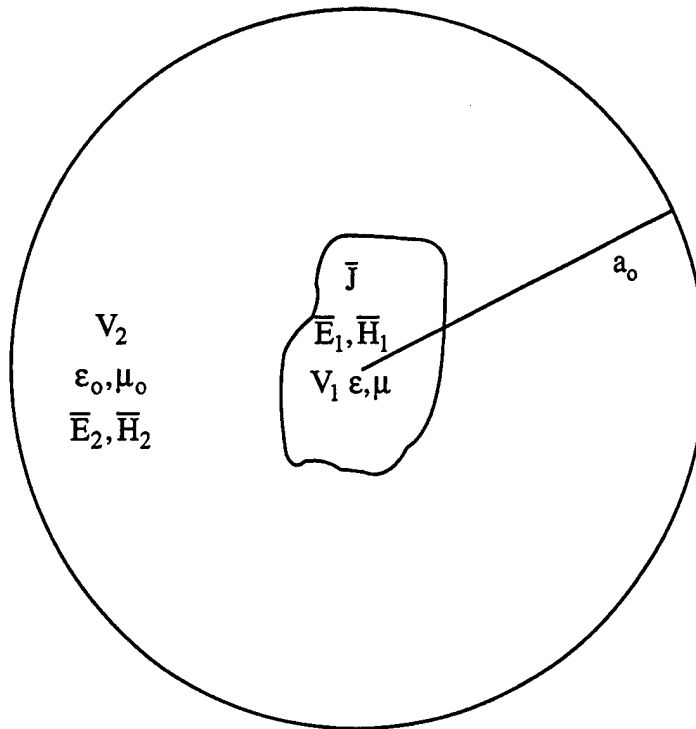

FIGURE 2. Complex Surface of Integration for the Complex Poynting Theorem With Actual Antenna Included.

On the other hand, if one tries to work with Equation 9, noting the lack of singularity so that an inner and an outer sphere need not be considered, one would have

$$\left[\oint_A \bar{E}_2 \times \bar{H}_2^* \cdot d\bar{a} \right]_{a_0} = j\omega \int_{V_1} (\epsilon_1 \bar{E}_1 \cdot \bar{E}_1^* - \mu_1 \bar{H}_1 \cdot \bar{H}_1^*) dv$$

$$+ j\omega \int_{V_2} (\epsilon_0 \bar{E}_2 \cdot \bar{E}_2^* - \mu_0 \bar{H}_2 \cdot \bar{H}_2^*) dv - \int_{V_1} \bar{E}_1 \cdot \bar{J}^* dv .$$

Now, while \bar{E}_1 , \bar{H}_1 , \bar{E}_2 , and \bar{H}_2 are all solutions to Maxwell's equations and are constrained by the usual boundary conditions, they are not the same functions, in general, as shown by the lack of singularities in \bar{E}_1 and \bar{H}_1 and the existence of \bar{J} in only V_1 . However, if \bar{E} and \bar{H} (or at least $\nabla \cdot \bar{E} \times \bar{H}^*$) are not the same functions of the coordinates in both V_1 and V_2 , the divergence theorem does not apply.

Thus if we are considering a volume with $\bar{f}(r)$ in one part and $\bar{g}(r)$ in another part, the divergence theorem can be applied to the surface of that part of the volume that contains $\bar{f}(r)$ and to the surface of that part which contains $\bar{g}(r)$ separately, but not to the surface that encloses both volumes together (References 37 and 38). The volume must be *unifunctioned*.

The complex Poynting theorem is usually written in the form of Equation 9 and it will be observed that the surface integral in Equation 9 is just the power flow across a surface surrounding the antenna and the real part of that integral is the time average or radiated power flow across that surface. This is true if the surface integral is only evaluated at a_0 but this has little to do with Poynting's theorem per se; i.e., this could have been simply stated without ever deriving the theorem.

In free space ϵ and μ are real, thus the first volume integral on the right hand side of Equation 9 is imaginary. Since a_1 is taken to be the radius of a sphere large enough to enclose the antenna (where \bar{J} is zero outside such a sphere), the second volume integral on the right is zero, leaving the right-hand side of Equation 9 imaginary. It follows that the left-hand side of Equation 9 must also be imaginary, as indeed it is if the integration is over the complete surface as in Equation 10.

Physical reasoning shows that this must be the case. If the surface integral over $(1/2)\text{Re}(\bar{E} \times \bar{H}^*)$ is the time average radiated power, and then it must be the same for any sphere surrounding the antenna, i.e., $\text{Re} \int_A \bar{E} \times \bar{H}^* \cdot d\bar{a}$ is independent of the spherical radius.

However, performing the integral over the complete surface is the same as

$$\left[\int_A \bar{E} \times \bar{H}^* \cdot d\bar{a} \right]_{a_1, a_0} = \int_A \bar{E} \times \bar{H}^* \cdot \hat{N}_i da \Big|_{a_1} + \int_A \bar{E} \times \bar{H}^* \cdot \hat{N}_o da \Big|_{a_0}$$

But the outward normal at a_0 is $\hat{N}_o = \hat{r}$, and at a_1 , the inner normal is $\hat{N}_i = -\hat{r}$, so the real parts must cancel.

As a corollary, since $\text{Re}[\bar{E} \times \bar{H}^* \cdot d\bar{a}]$ is independent of radius and the increment of area is

$$da = r^2 \sin \theta \, d\theta \, d\phi, \quad (12)$$

the real part of $\bar{E} \times \bar{H}^*$ must go as $1/r^2$ so the integration will be independent of r , and only those portions of \bar{E} and \bar{H} that go as $1/r$ contribute to the radiated power.

To sum up this section, those who write Poynting's theorem (Reference 26) in the form of Equation 9, then state that the real part of the left hand side of Equation 9 represents radiated power are, at best, misleading. They should state that the time average radiated power is indeed given by $(1/2)\text{Re} \int_A \bar{E} \times \bar{H}^* \cdot d\bar{a}$ on a sphere external to

the antenna, but that this is not actually part of Poynting's theorem which is correctly expressed by Equation 10 (with care) or by Equation 11 for the case of antennas where there is a singularity at the origin.

Finally, Poynting's theorem can be confusing in another way, insofar as the dielectric constant, ϵ , and magnetic permeability, μ , are concerned. At least one text (Reference 30) notes that the imaginary part of the first integral on the right hand side of Equation 9 (which should be written as Equation 10), upon being multiplied by j , represents dissipated energy. If one understands this to mean that ϵ is the complex dielectric constant as usually defined from

$$\nabla \times \bar{H} = \bar{J}_c + \partial \bar{D} / \partial t = \sigma \bar{E} + j\omega \epsilon_0 \epsilon' \bar{E} = j\omega \epsilon_0 (\epsilon' - j\sigma / \omega \epsilon_0) \bar{E} = j\omega \epsilon_0 \epsilon_c \bar{E} ,$$

one would be wrong. In deriving Poynting's theorem the conduction current was already taken into account. Thus, in Equations 8, 9, and 10, ϵ is real ($= \epsilon_0 \epsilon'$), unless some kind of losses other than conduction losses have been included in the displacement current term in Maxwell's equation.

That this is so can be seen as follows. Consider some volume in space characterized by ϵ , μ , and σ where there is a current density \bar{J} , and electric and magnetic fields \bar{E} and \bar{H} . It is assumed that in this volume these quantities are everywhere finite (no singularities--it can be argued that for any physically real situation this must be the case). In this case, Equation 9 applies without any need for an inner and an outer surface--only the outer surface need be used.

It follows, in this case, that the left-hand side of Equation 9 will have both real and imaginary parts, with the real part representing the radiation out of the volume V . It will be assumed, for this example, that $\mu = \mu_0$, and the current, \bar{J} , is given by Ohm's law,

$$\bar{J} = \sigma \bar{E} \tag{13}$$

where σ is real.

If it were assumed that ϵ_c is the complex dielectric constant as given by $\epsilon_c = \epsilon_0(\epsilon' - j\sigma/\omega \epsilon_0)$ with ϵ' and σ real, the right-hand side of Equation 9 becomes

$$\begin{aligned} & j\omega \int_V \epsilon_0 (\epsilon' - j\sigma / \omega \epsilon_0) \bar{E} \cdot \bar{E}^* dv - j\omega \int_V \mu_0 \bar{H} \cdot \bar{H}^* dv - \int_V \sigma \bar{E} \cdot \bar{E}^* dv \\ & = j\omega \int_V (\epsilon_0 \epsilon' \bar{E} \cdot \bar{E}^* - \mu_0 \bar{H} \cdot \bar{H}^*) dv \end{aligned}$$

That is, the right-hand side of Equation 9 would be totally imaginary, which, of course, is impossible since power is radiated and the left-hand side has a real part. Clearly one has to be very careful in interpreting and applying the complex Poynting's theorem.

TIME DEPENDENT POYNTING'S THEOREM (GENERAL CASE)

Beginning with the vector identity

$$\nabla \cdot \bar{\mathcal{E}}(t) \times \bar{\mathcal{H}}(t) = \bar{\mathcal{H}}(t) \cdot \nabla \times \bar{\mathcal{E}}(t) - \bar{\mathcal{E}}(t) \cdot \nabla \times \bar{\mathcal{H}}(t) \quad (14)$$

where $\bar{\mathcal{E}}(t)$ and $\bar{\mathcal{H}}(t)$ are general real (physical) time dependent fields,

Maxwell's equations are now

$$\nabla \times \bar{\mathcal{E}}(t) = -\partial \bar{\mathcal{B}}(t) / \partial t \quad , \quad (15a)$$

$$\nabla \times \bar{\mathcal{H}}(t) = \bar{\mathcal{J}}(t) + \partial \bar{\mathcal{D}}(t) / \partial t \quad . \quad (15b)$$

Substituting Equation 15a and b into Equation 14 gives

$$\nabla \cdot \bar{\mathcal{E}}(t) \times \bar{\mathcal{H}}(t) = -\bar{\mathcal{H}}(t) \cdot \partial \bar{\mathcal{B}}(t) / \partial t - \bar{\mathcal{E}}(t) \cdot \bar{\mathcal{J}}(t) - \bar{\mathcal{E}}(t) \cdot \partial \bar{\mathcal{D}}(t) / \partial t \quad . \quad (16)$$

Integrating both sides over a volume in accordance with the previous section and applying the divergence theorem:

$$\begin{aligned} \oint_A \bar{\mathcal{E}}(t) \times \bar{\mathcal{H}}(t) \cdot d\bar{a} &= \int_V \nabla \cdot \bar{\mathcal{E}}(t) \times \bar{\mathcal{H}}(t) dv \\ &= -\int_V [\bar{\mathcal{H}}(t) \cdot \partial \bar{\mathcal{B}}(t) / \partial t + \bar{\mathcal{E}}(t) \cdot \partial \bar{\mathcal{D}}(t) / \partial t] dv - \int_V \bar{\mathcal{E}}(t) \cdot \bar{\mathcal{J}}(t) dv \quad . \end{aligned} \quad (17)$$

Assuming that $\bar{\mathcal{E}}(t)$, $\bar{\mathcal{H}}(t)$, and $\bar{\mathcal{J}}(t)$ has the sinusoidal time dependence of Equation 3a and b and that

$$\bar{\mathcal{D}} = \epsilon \bar{\mathcal{E}} \quad (18a)$$

$$\bar{\mathcal{B}} = \mu \bar{\mathcal{H}} \quad , \quad (18b)$$

Equation 17 becomes

$$\oint_A \bar{\mathcal{E}} \times \bar{\mathcal{H}} \cdot d\bar{a} = - \int_V (\mu \bar{\mathcal{H}} \cdot \partial \bar{\mathcal{H}} / \partial t + \epsilon \bar{\mathcal{E}} \cdot \partial \bar{\mathcal{E}} / \partial t) dv - \int_V \bar{\mathcal{E}} \cdot \bar{\mathcal{J}} dv \quad (19)$$

Equation (19) can just as well be written in the form

$$\oint_A \bar{\mathcal{E}} \times \bar{\mathcal{H}} \cdot d\bar{a} = -(1/2) \frac{\partial}{\partial t} \int_V (\mu \bar{\mathcal{H}} \cdot \bar{\mathcal{H}} + \epsilon \bar{\mathcal{E}} \cdot \bar{\mathcal{E}}) dv - \int_V \bar{\mathcal{E}} \cdot \bar{\mathcal{J}} dv \quad (20)$$

The same rules regarding the divergence theorem apply as in the previous section that the volume must contain no singularities and that $\bar{\mathcal{E}}$, $\bar{\mathcal{H}}$, and $\bar{\mathcal{J}}$ must be the same functions throughout the volume.

Choosing an inner sphere that encloses the antenna and any outer sphere to meet these criteria,

$$\left[\oint_A \bar{\mathcal{E}} \times \bar{\mathcal{H}} \cdot d\bar{a} \right]_{a_i, a_o} = - \frac{\partial}{\partial t} \int_V (\mu \bar{\mathcal{H}} \cdot \bar{\mathcal{H}} / 2 + \epsilon \bar{\mathcal{E}} \cdot \bar{\mathcal{E}} / 2) dv \quad (21)$$

One can recognize the sum of $\epsilon(\bar{\mathcal{E}} \cdot \bar{\mathcal{E}})/2$ and $\mu(\bar{\mathcal{H}} \cdot \bar{\mathcal{H}})/2$ as the total electric and magnetic energy per unit volume in V. Thus

$$\left[\oint_A \bar{\mathcal{E}} \times \bar{\mathcal{H}} \cdot d\bar{a} \right]_{a_i, a_o} = -\partial U / \partial t \quad (22)$$

where U is the total energy in the volume, V.

What is the relationship between Equations 21 and 11? After all, complex numbers cannot truly represent physical fields. From Equation 3a and b

$$\begin{aligned} \bar{\mathcal{E}} \cdot \bar{\mathcal{E}} &= (\bar{E}_0' \cos \omega t + \bar{E}_0'' \sin \omega t) \cdot (\bar{E}_0' \cos \omega t + \bar{E}_0'' \sin \omega t) \\ &= (E_0')^2 \cos^2 \omega t + (E_0'')^2 \sin^2 \omega t + 2\bar{E}_0' \cdot \bar{E}_0'' \sin \omega t \cos \omega t \end{aligned}$$

Finally, with the use of trigonometric identities,

$$\begin{aligned}\bar{\mathcal{E}} \cdot \bar{\mathcal{E}} / 2 &= (1/4)\left((E_0')^2 + (E_0'')^2\right) + (1/4)\left((E_0')^2 - (E_0'')^2\right)\cos 2\omega t \\ &+ (1/2)\bar{E}_0' \cdot \bar{E}_0'' \sin 2\omega t\end{aligned}\quad (23a)$$

and it follows that

$$\begin{aligned}\bar{\mathcal{H}} \cdot \bar{\mathcal{H}} / 2 &= (1/4)\left((H_0')^2 + (H_0'')^2\right) + (1/4)\left((H_0')^2 - (H_0'')^2\right)\cos 2\omega t \\ &+ (1/2)\bar{H}_0' \cdot \bar{H}_0'' \sin 2\omega t\end{aligned}\quad (23b)$$

Now

$$\bar{\mathcal{E}} \cdot \bar{\mathcal{E}}^* = \left(\bar{E}_0' - j\bar{E}_0''\right)e^{j\omega t} \cdot \left(\bar{E}_0' + j\bar{E}_0''\right)e^{-j\omega t} = (E_0')^2 + (E_0'')^2 \quad (24a)$$

and

$$\bar{\mathcal{H}} \cdot \bar{\mathcal{H}}^* = (H_0')^2 + (H_0'')^2 \quad (24b)$$

Therefore, $\epsilon \bar{\mathcal{E}} \cdot \bar{\mathcal{E}}^* / 4$ is the *time average* energy per unit volume in the electric field, and $\mu \bar{\mathcal{H}} \cdot \bar{\mathcal{H}}^* / 4$ is the *time average* magnetic energy per unit volume.

On the other hand

$$\begin{aligned}\bar{\mathcal{E}} \times \bar{\mathcal{H}} &= \left(\bar{E}_0' \cos \omega t + \bar{E}_0'' \sin \omega t\right) \times \left(\bar{H}_0' \cos \omega t + \bar{H}_0'' \sin \omega t\right) \\ &= (1/2)\left(\bar{E}_0' \times \bar{H}_0' + \bar{E}_0'' \times \bar{H}_0''\right) + (1/2)\left(\bar{E}_0' \times \bar{H}_0'' - \bar{E}_0'' \times \bar{H}_0'\right)\cos 2\omega t \\ &+ (1/2)\left(\bar{E}_0' \times \bar{H}_0'' + \bar{E}_0'' \times \bar{H}_0'\right)\sin 2\omega t\end{aligned}\quad (25)$$

while

$$\begin{aligned} \bar{E} \times \bar{H}^* &= (\bar{E}_0' - j\bar{E}_0'') e^{j\omega t} \times (\bar{E}_0' + j\bar{E}_0'') e^{-j\omega t} \\ &= (\bar{E}_0' \times \bar{H}_0' + \bar{E}_0'' \times \bar{H}_0'') + j(\bar{E}_0' \times \bar{H}_0'' - \bar{E}_0'' \times \bar{H}_0') \end{aligned} \quad (26)$$

Comparing Equations 25 and 26 one finds

$$(1/2)\text{Re}(\bar{E} \times \bar{H}^*) = \overline{(\bar{E} \times \bar{H})} \quad (27)$$

where the bar means time average. The imaginary part of $\bar{E} \times \bar{H}^*$, however, bears no obvious relation to any part of Equation 25 except that it is the difference instead of the sum of the quantities in brackets in the coefficient of $\sin 2\omega t$ in Equation 25.

SUMMARY AND DISCUSSION OF POYNTING'S THEOREMS

Given time domain variation of the fields and currents (Equation 3a and b), the time domain form of Poynting's theorem is

$$\oint_A \bar{E} \times \bar{H} \cdot d\bar{a} = -\frac{\partial}{\partial t} \int_V (\mu \bar{H} \cdot \bar{H} / 2 + \epsilon \bar{E} \cdot \bar{E} / 2) dv - \int_V \bar{E} \cdot \bar{j} dv$$

where the volume integrated over can be *any* volume with the surface integral being over the *complete* surface of that volume. This is provided the volume integrated over contains no singularities and \bar{E} , \bar{H} , and \bar{j} are the *same* vector functions throughout that volume.

The time harmonic or complex form of Poynting's theorem is

$$(1/2) \oint_A \bar{E} \times \bar{H}^* \cdot d\bar{a} = j2\omega \int_V (\epsilon \bar{E} \cdot \bar{E}^* / 4 - \mu \bar{H} \cdot \bar{H}^* / 4) dv - (1/2) \int_V \bar{E} \cdot \bar{j} dv$$

This is actually Equation 9 rewritten slightly to emphasize the time average relations between Equation 9 and the previous equation. The same conditions as to the volume, surface, and functions integrated over apply, and it should be noted that while Equation 9 is mathematically correct, \bar{E} and \bar{H} are not physically realizable fields.

The usual solutions (the spherical Hankel functions) for radiation in spherical coordinates contains a singularity at the origin, therefore, if these fields are to be used the

volume must exclude the origin. Real antennas are finite in extent and generally the fields and currents in the volume actually containing the antenna are not functionally the same as the fields and currents (usually zero) exterior to the antenna, *even* though these fields must meet the usual boundary conditions of continuous tangential \vec{E} and \vec{H} with the interior fields. Therefore, the volume must exclude the actual antenna as well as the origin for Poynting's theorem to be applicable.

Typically \vec{j} is zero exterior to the antenna and, given that we are usually interested in a volume that surrounds the antenna in order to determine radiated power, Poynting's theorem reduces to

$$\left[\oint_A \vec{E} \times \vec{H} \cdot d\vec{a} \right]_{A_i, A_o} = -\frac{\partial}{\partial t} \int_V (\mu \vec{H} \cdot \vec{H} / 2 + \epsilon \vec{E} \cdot \vec{E} / 2) dv \quad (28)$$

where the volume V is the volume between any inner surface A_i , which surrounds the antenna and any outer surface, A_o , which also surrounds the antenna.

The equivalent form for the complex Poynting theorem is

$$\frac{1}{2} \left[\oint_A \vec{E} \times \vec{H}^* \cdot d\vec{s} \right]_{A_i, A_o} = j2\omega \int_V (\epsilon \vec{E} \cdot \vec{E}^* / 4 - \mu \vec{H} \cdot \vec{H}^* / 4) dv \quad (29)$$

Both sides of Equation 29 are purely imaginary.

Because closed form integration over anything but spherical surfaces in spherical coordinates can be at least tedious if not impossible, A_i and A_o are easiest to work with if they are spherical so that a_i is the radius of the smallest sphere, which will contain the antenna, whether the antenna is spherical or not, and a_o is the radius of any sphere exterior to this with the same origin, in which case Poynting's theorems become:

$$\left[\oint_A \vec{E} \times \vec{H} \cdot d\vec{a} \right]_{a_i, a_o} = -\frac{\partial}{\partial t} \int_V (\mu \vec{H} \cdot \vec{H} / 2 + \epsilon \vec{E} \cdot \vec{E} / 2) dv = -\partial U / \partial t$$

and

$$\frac{1}{2} \left[\oint_A \vec{E} \times \vec{H}^* \cdot d\vec{a} \right]_{a_i, a_o} = j2\omega \int_V (\epsilon \vec{E} \cdot \vec{E}^* / 4 - \mu \vec{H} \cdot \vec{H}^* / 4) dv$$

Note that $\epsilon \vec{E} \cdot \vec{E}^* / 4$ is the time average of $\epsilon \vec{E} \cdot \vec{E} / 2$, i.e., the time average of the total electric energy per unit volume in V . The same relation holds for $\mu \vec{H} \cdot \vec{H}^* / 4$ and

$\mu \bar{\mathcal{H}} \cdot \bar{\mathcal{H}} / 2$. The right-hand side of Equation 21 is the time derivative of the total electromagnetic energy in the volume V , whereas the right-hand side of Equation 11 is $j2\omega$ times the difference between the time averages of the magnetic and electric energies in V .

Finally, it is noted (and this is separate from Poynting's theorem) that

$$P_A = (1/2) \operatorname{Re} \oint_A \bar{\mathbf{E}} \times \bar{\mathbf{H}}^* \cdot d\bar{\mathbf{a}} \quad (30)$$

where the above integral is around any surface surrounding the antenna and P_A is the time average power flow across that surface, i.e., the radiated power, while

$$P_i = \oint_A \bar{\mathbf{E}} \times \bar{\mathcal{H}} \cdot d\bar{\mathbf{a}} \quad (31)$$

is the instantaneous power flow across that surface.

Note that, in general

$$P_i \neq -\frac{\partial}{\partial t} \int_V (\mu \bar{\mathcal{H}} \cdot \bar{\mathcal{H}} / 2 + \epsilon \bar{\mathbf{E}} \cdot \bar{\mathbf{E}} / 2) dv$$

and

$$P_A \neq \operatorname{Re} \left[j2\omega \int_V (\epsilon \bar{\mathbf{E}} \cdot \bar{\mathbf{E}}^* / 4 - \mu \bar{\mathbf{H}} \cdot \bar{\mathbf{H}}^* / 4) dv \right]$$

as the right-hand side of the latter doesn't usually exist in most cases of interest.

A reasonably clear picture of Poynting's theorem(s), power flow across a surface surrounding an antenna, and energy contained in the volume surrounding the antenna is now achieved.

The question arises as to how to employ these concepts to tell something about the antenna that one needs or wants to know. Of course, to carry out the integration, dot and cross products etc., the presumption is that one already knows the mathematical forms of the electric and magnetic fields. If this is so, one already has the information needed for the antenna pattern, gain, beamwidth, sidelobe levels, polarization, etc. In addition to these things it would generally be useful to know some other properties, like input impedance and bandwidth, i.e., the behavior of the input impedance with frequency.

Engineers typically relate input impedance and bandwidth to concepts such as resistive and reactive power flow, equivalent circuits, and the quality factor, Q . The latter is usually found through ad hoc relations such as

$$Q = f_0 / \Delta f \quad (32)$$

where f_0 is the operating or resonant frequency and Δf the 3 dB bandwidth around f_0 . The equation for the Q is often given also as a relation between stored energy and dissipated power as

$$Q = \omega U_s / W_L \quad (33)$$

where W_L is the time average power loss and U_s is the energy stored in the circuit. The implication, of course, is that "high Q " circuits have a narrow operating bandwidth. The power lost, W_L , can be identified as the power radiated, Equation 30, in the absence of additional ohmic losses in the antenna. The reactive energy stored can be found by the proper integration over $\vec{E} \cdot \vec{E}$ and $\vec{H} \cdot \vec{H}$, using the reactive fields.

Papers on the fundamental limits of antennas have followed this general procedure in one fashion or another to show that for electrically small antennas the ratio of the reactive energy stored in the antenna fields to the average power radiated is large (References 1, 3, and 7). It is then concluded with reference to Equation 32 that since the Q is high, these are intrinsically narrowband devices. Although there is obviously a certain validity to this general approach, one has to be extremely careful not to push it too far. Although Equations 32 and 33 may be wonderful generalizations which seem almost intuitive through long acquaintance, they need careful examination when applied to a particular antenna or antenna system. As always, the devil is in the details.

It is common practice in antenna texts to use the term "radiation resistance," usually found by employing Equation 30 together with

$$P_A = I_0^2 R_r / 2 \quad (34)$$

where I_0 is the input current to the antenna and R_r is the radiation resistance. When this definition is applied to an infinitesimal dipole one gets the usual formula (References 26 through 28)

$$R_r = 80\pi^2 (\Delta z / \lambda)^2 \quad (35a)$$

or, for a short dipole with a physically reasonable current distribution

$$R_r = 20\pi^2(h/\lambda)^2 \quad (35b)$$

where Δz and h are the dipole lengths.

While the radiation resistance is a seemingly straightforward concept, it too can have its problems. It is one thing to apply it to an antenna with a single pair of input terminals where the current is known at those terminals; it is another thing to find the meaning in the case of an antenna array (Reference 40).

RESISTIVE AND REACTIVE POWER FLOW AND EQUIVALENT CIRCUITS

Consider the series RLC circuit shown in Figure 3 with an applied voltage

$$V = V_0 \cos \omega t \quad (36)$$

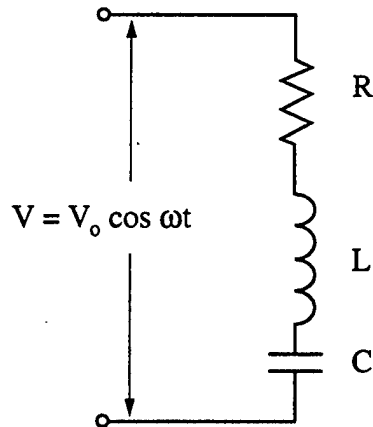

FIGURE 3. Series RLC Circuit With Applied Voltage, V .

The current through the circuit must therefore be

$$I = \text{Re}(V_0 e^{j\omega t} / Z) \quad (37a)$$

where the impedance, Z , is

$$Z = R + jX = R + j(\omega L - 1/\omega C) \quad (37b)$$

or

$$Z = |Z| \exp(j \tan^{-1}(X/R)) = |Z| e^{j\phi} \quad (37c)$$

The current then becomes

$$I = (V_0 / |Z|) \operatorname{Re} \left[e^{j(\omega t - \phi)} \right] = (V_0 / |Z|) \cos(\omega t - \phi) = I_0 \cos(\omega t - \phi) \quad (38)$$

and the power into the circuit is thus, using Equations 36 and 38,

$$P = IV = \left(V_0^2 / |Z| \right) \cos \omega t \cos(\omega t - \phi) \quad (39)$$

Using the double angle formula,

$$P = \left(V_0^2 / |Z| \right) \cos \omega t (\cos \phi \cos \omega t + \sin \phi \sin \omega t) \quad (40)$$

However,

$$\cos \phi = 1 / \sqrt{1 + \tan^2 \phi} = \cos \tan^{-1} \frac{X}{R} = R / |Z| \quad (41a)$$

and

$$\sin \phi = \tan \phi / \sqrt{1 + \tan^2 \phi} = X / |Z| \quad (41b)$$

Substituting these into Equation 40 we have

$$P = \left(V_0^2 / 2|Z|^2 \right) [R(1 + \cos 2\omega t) + X \sin 2\omega t] \quad (42)$$

The first term of Equation 42 ranges between zero and $V_0^2 R / |Z|^2 = I_0^2 R$ and would seem logically to be associated with the time dependence of the resistive power loss, while the second term ranges between $-I_0^2 X / 2$ and $I_0^2 X / 2$ and could be associated with the reactive power being alternately supplied by and returned to the source.

Such an interpretation sounds plausible (Reference 24), but is, in this case, technically incorrect. This is readily shown by using the reactive power as the derivative with respect to time of the reactive energy, i.e.,

$$P_{Xi} = \partial U_{Xi} / \partial t \quad . \quad (43)$$

The reactive energy in the inductance is

$$U_{Li} = I^2 L / 2 \quad (44a)$$

and in the capacitor

$$U_{Ci} = C V_C^2 / 2 \quad (44b)$$

where V_C is the voltage across the capacitor.

Now

$$U_{Li} = (V_0^2 / 2 |Z|^2) L \cos^2(\omega t - \phi) = (V_0^2 L / 4 |Z|^2) [1 + \cos 2(\omega t - \phi)] \quad . \quad (45)$$

The voltage across the capacitor is

$$V_C = \mathbf{Re}(I / j\omega C) = \mathbf{Re}(-jV_0 / \omega C |Z|) \exp[j(\omega t - \phi)]$$

or

$$V_C = (V_0 / \omega C |Z|) \sin(\omega t - \phi) \quad . \quad (46a)$$

Thus

$$U_{Ci} = (V_0^2 / 2 \omega^2 C |Z|^2) \sin^2(\omega t - \phi) = (V_0^2 / 4 \omega^2 C |Z|^2) [1 - \cos 2(\omega t - \phi)] \quad . \quad (46b)$$

The total reactive energy is then

$$U_{Xi} = \frac{V_0^2}{4\omega|Z|^2} [(\omega L + 1/\omega C) + (\omega L - 1/\omega C) \cos 2(\omega t - \phi)] \quad (47)$$

which has an interesting symmetry.

Substituting Equation 47 into Equation 43

$$P_{Xi} = \left(-V_0^2 X / 2|Z|^2\right) \sin 2(\omega t - \phi) \quad (48)$$

which is of a different phase and sign than $(V_0^2 X / 2|Z|^2) \sin 2\omega t$ as could be gathered from Equation 42 although the magnitudes of Equation 42 and Equation 48 are the same.

One can obtain the correct answer by finding the resistive power loss directly as

$$P_r = I^2 R = (V_0^2 R / |Z|^2) \cos^2(\omega t - \phi) = (V_0^2 R / 2|Z|^2) [1 + \cos 2(\omega t - \phi)] \quad (49)$$

and postulating (note that we cannot set $P_x = I^2 X$) that the total power flow must be Equation 49 combined with Equation 48:

$$P = (V_0^2 / 2|Z|^2) \{R [1 + \cos 2(\omega t - \phi)] - X \sin 2(\omega t - \phi)\} \quad (50)$$

It only remains to show that Equations 50 and 42 are equal. They are and this will be shown in Appendix B.

The reactive power flow could have been derived directly by observing that

$$P_X = IV_X \quad (51)$$

where

$$V_X = \text{Re}[jIX] = \text{Re}[jXV_0 e^{j\omega t} / Z] \quad (52)$$

or

$$P_X = -(V_0 X |Z|) \sin(\omega t - \phi) (V_0 / |Z|) \cos(\omega t - \phi) = -(V_0^2 X / 2|Z|^2) \sin 2(\omega t - \phi)$$

which is, of course, Equation 48.

In general, as shown in Appendix B, if the applied voltage and current are given by

$$V(t) = V_0 \cos(\omega t - \alpha) \quad (53a)$$

and

$$I(t) = I_0 \cos(\omega t - \beta) \quad (53b)$$

then $P = IV$ can be written in two ways, either

$$P = (V_0 I_0 / 2) \{ \cos(\alpha - \beta) [1 + \cos 2(\omega t - \beta)] + \sin(\alpha - \beta) \sin 2(\omega t - \beta) \} \quad (54a)$$

or

$$P = (V_0 I_0 / 2) \{ \cos(\alpha - \beta) [1 + \cos 2(\omega t - \alpha)] - \sin(\alpha - \beta) \sin 2(\omega t - \alpha) \} \quad (54b)$$

In any given case, only one of these two expressions can be (directly and correctly) broken into resistive and reactive power flow. The importance of this will become clearer when resistive and reactive power flow in relation to the Poynting vector is examined.

Before this is done, however, there are a couple of points to be made. If one considers a single antenna as a (one port or two terminal) black box which contains any series/parallel combination of capacitors, inductors, and resistors, and if one applies a signal at any single frequency, one can measure an input impedance consisting of a real resistance, and a series reactance. The exact relation to the various resistors and reactance (capacitors and inductors) actually in the box depends on their values and series/parallel arrangement. In fact, from a measurement at a single frequency with no other a priori knowledge as to the contents of the box, one has no information as to what the box actually contains other than, if there is a real part to the input impedance, there must be at least one resistor in the box, and if there is an imaginary part, at least one reactive element. Even if one has a priori knowledge of what the box contains, for example, a series RLC circuit, a measurement at a single frequency suffices only to give the value of the resistance and the reactance, but not L or C individually. Clearly, if the box contains frequency independent resistors, capacitors and inductors, and one wishes to find their values and their series/parallel arrangements, one must measure the input admittance or impedance as a function of frequency and endeavor to find that combination of frequency independent elements that gives the measured frequency dependence.

The alternative would be to assign frequency dependent elements such that the observed frequency dependence is $Z(\omega) = R(\omega) + jX(\omega)$. Regardless, the power flow at any frequency can be written in the form of either Equation 42 or Equation 50.

To illustrate this point, suppose the black box contains not the series RLC circuit of Figure 3, but the parallel RLC circuit of Figure 4. The input admittance is

$$Y = G + jB = 1/R + j(\omega C - 1/\omega L) . \quad (56)$$

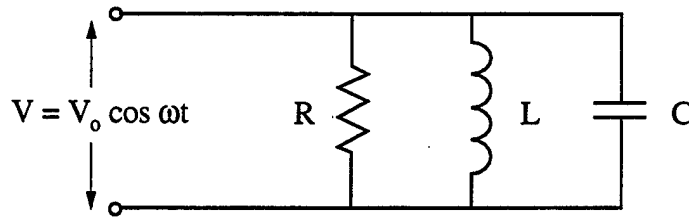

FIGURE 4. Parallel RLC Circuit With Applied Voltage, V.

The input impedance is

$$Z = 1/Y = (G - jB)/(G^2 + B^2) . \quad (57)$$

The power dissipated in the resistance is

$$P_R = I_r^2 R = V^2 / R = V_0^2 G \cos^2 \omega t = (V_0^2 G / 2)(1 + \cos 2\omega t) . \quad (58)$$

The capacitor current is

$$I_c = \text{Re}[V_0 e^{j\omega t} / X_c] = \text{Re}[j\omega C V_0 e^{j\omega t}] = -V_0 \omega C \sin \omega t \quad (59)$$

and for the inductor current

$$I_L = \text{Re}[V_0 e^{j\omega t} / j\omega L] = (V_0 / \omega L) \sin \omega t . \quad (60)$$

The power flow to the capacitor is

$$P_C = I_C V = -(V_0^2 \omega C / 2) \sin 2\omega t \quad (61)$$

and to the inductor,

$$P_L = I_L V = (V_0^2 / 2\omega L) \sin 2\omega t . \quad (62)$$

The total power flow is then

$$P = P_R + P_C + P_L = \left(V_0^2 / 2 \right) \left[G(1 + \cos 2\omega t) - (\omega C - 1 / \omega L) \sin 2\omega t \right] \quad (63a)$$

or

$$P = \left(V_0^2 / 2 \right) \left[G(1 + \cos 2\omega t) - B \sin 2\omega t \right] \quad (63b)$$

In terms of the previous discussion, Equation 63 must be the same as Equations 42 or 50, which are identities. Choosing Equation 42 as the simpler case, we must have

$$\left(V_0^2 / 2 \right) \left[G(1 + \cos 2\omega t) - B \sin 2\omega t \right] = \left(V_0^2 / 2 |Z|^2 \right) \left[R(1 + \cos 2\omega t) + X \sin 2\omega t \right] \quad .$$

Substituting from Equation 57 this is the same as

$$G(1 + \cos 2\omega t) - B \sin 2\omega t = \left[G(1 + \cos 2\omega t) - B \sin 2\omega t \right] \left(|Z|^2 (G^2 + B^2) \right)^{-1} \quad .$$

Since $Z = 1/Y$,

$$|Z|^2 = 1/|Y|^2 = 1/(G^2 + B^2) \quad , \quad (64)$$

one arrives at $G(1 + \cos 2\omega t) - B \sin 2\omega t = G(1 + \cos 2\omega t) - B \sin 2\omega t$, which is the expected result.

If the black box contains an antenna, then an antenna is by no means an RLC circuit but rather a distributed one. Nonetheless, at the input terminals one will measure some input impedance with a power flow which can be written in the form of Equation 42 or its identity, Equation 50. Knowing the input voltage and current one will know whether the input is capacitive or inductive and whether Equation 42 or 50 is appropriate from the aspect of reactive and resistive power flow. If one measures the input impedance as a function of frequency, one can attempt to establish an equivalent circuit for the antenna, either a circuit that involves frequency dependent elements or a circuit involving frequency independent elements.

It is, however, a goal of antenna theorists to establish the input impedance theoretically. Logically, the first step is to find the "radiation resistance" via the power radiated, i.e., the surface integral of the Poynting vector over a sphere surrounding the antenna. Here the real part of the complex Poynting vector can be used or, if the (physical) Poynting vector is employed, those terms with radial dependence of $1/r^2$.

The power radiated is generally found in terms of the assumed antenna current squared, and hence is related to the term $I^2 R_r$, where I is the input current to the antenna and R_r is the radiation resistance. Employed this way, R_r is obviously a series element, and will generally be found to be frequency dependent. For small dipoles (References 26 and 28) the radiation resistance is given as

$$R_r = 80\pi^2 (h/\lambda)^2 \quad (65a)$$

for an assumed uniform current distribution and

$$R_r = 20\pi^2 (h/\lambda)^2 \quad (65b)$$

for an assumed sinusoidal current distribution.

In either case, R_r goes as one over the wavelength squared, i.e., as the frequency squared. Thus any series equivalent circuit employing the radiation resistance involves frequency dependent circuit elements. Thus one can see the motivation in using this same integral to find the radiation reactance, and perhaps extending it to the concepts of Q and bandwidth.

Finally one can note that while the concepts of radiation resistance, radiation reactance, and antenna input impedance seem conceptually clear for antennas with a single input port (actually there are caveats even here), these concepts become much more complicated in dealing with antenna arrays (antennas with multiple input ports). This has been covered to a limited extent in an earlier report (Reference 40).

POWER FLOW AND POYNTING'S VECTOR.

One can return to Equation 25 and rewrite it as (References 14 and 15)

$$\bar{S} = \bar{\mathcal{E}} \times \bar{\mathcal{H}} = \bar{N}_0 + \bar{N}_1 \cos 2\omega t + \bar{N}_2 \sin 2\omega t \quad (66a)$$

where

$$\bar{N}_0 = (\bar{E}_0' \times \bar{H}_0' + \bar{E}_0'' \times \bar{H}_0'')/2 \quad , \quad (66b)$$

$$\bar{N}_1 = (\bar{E}_0' \times \bar{H}_0' - \bar{E}_0'' \times \bar{H}_0'')/2 \quad , \quad (66c)$$

and

$$\bar{N}_2 = \left(\bar{E}_0' \times \bar{H}_0'' + \bar{E}_0'' \times \bar{H}_0' \right) / 2 \quad (66d)$$

If one integrates \bar{S} , as in Equation 31, on a surface surrounding the antenna, the result will be the instantaneous power flow across that surface. If the surface chosen is spherical and centered on the antenna, then da is given by Equation 12 and $d\bar{a}$ is in the direction of \hat{r} . Thus only the radial component of Equation 66 enters into the integration and

$$P = \oint_A N_{0r} r^2 \sin \theta d\theta d\phi + \cos 2\omega t \oint_A N_{1r} r^2 \sin \theta d\theta d\phi + \sin 2\omega t \oint_A N_{2r} r^2 \sin \theta d\theta d\phi \quad (67)$$

which can be written as

$$P = M_0 + M_1 \cos 2\omega t + M_2 \sin 2\omega t \quad (68a)$$

where

$$M_0 = \oint_A N_{0r} r^2 \sin \theta d\theta d\phi \quad (68b)$$

$$M_1 = \oint_A N_{1r} r^2 \sin \theta d\theta d\phi \quad (68c)$$

$$M_2 = \oint_A N_{2r} r^2 \sin \theta d\theta d\phi \quad (68d)$$

Generally speaking, the complex time harmonic solutions for the fields in antenna problems have the form of $F(r, \theta, \phi) \exp(-jkr) \exp(j\omega t)$. It is thus natural to combine ωt and $-kr$ as $\omega t - kr$, which can be written as ωt_r where

$$t_r = t - (k/\omega)r = t - r/c \quad (69)$$

t_r is called the retarded time and it simply means that physically the propagation time may be small but it is not zero. Some authors, notably Grimes, generally specify the use of retarded time in expressing power flow (Reference 22).

In fact one can always write Equations 1a and 1b in the form

$$\bar{E} = \bar{E}_1 \exp(j\omega t_r) = (\bar{E}_1' - j\bar{E}_1'') \exp(j\omega t_r) \quad , \quad (70a)$$

$$\bar{H} = \bar{H}_1 \exp(j\omega t_r) = (\bar{H}_1' - j\bar{H}_1'') \exp(j\omega t_r) \quad (70b)$$

so that

$$\bar{\mathcal{E}} = \bar{E}_1' \cos \omega t_r + \bar{E}_1'' \sin \omega t_r \quad (71a)$$

and

$$\bar{\mathcal{H}} = \bar{H}_1' \cos \omega t_r + \bar{H}_1'' \sin \omega t_r \quad . \quad (71b)$$

The relations between \bar{E}_1 , \bar{H}_1 and \bar{E}_0 , \bar{H}_0 are explored in Appendix C with the result that

$$\bar{E}_1' = \bar{E}_0' \cos kr + \bar{E}_0'' \sin kr \quad (72a)$$

$$\bar{E}_1'' = -\bar{E}_0' \sin kr + \bar{E}_0'' \cos kr \quad (72b)$$

$$\bar{E}_0' = \bar{E}_1' \cos kr - \bar{E}_1'' \sin kr \quad (72c)$$

$$\bar{E}_0'' = \bar{E}_1' \sin kr + \bar{E}_1'' \cos kr \quad (72d)$$

and a like set of equations relating \bar{H}_0 and \bar{H}_1 .

The mathematical manipulations remain unchanged so Equation 66a could just as well be written as

$$\bar{S} = \bar{N}_0' + \bar{N}_1' \cos 2\omega t_r + \bar{N}_2' \sin 2\omega t_r \quad (73a)$$

where

$$\bar{N}_0' = (\bar{E}_1' \times \bar{H}_1' + \bar{E}_1'' \times \bar{H}_1'') / 2 \quad (73b)$$

with similar expressions (from Equations 66c and b) for \bar{N}_1' and \bar{N}_2' .

The integration for P is over a surface and does not involve dr, thus $\sin 2\omega t_r$ and $\cos 2\omega t_r$ can also be pulled from under the integrals so that we can write

$$P = M_0' + M_1' \cos 2\omega t_r + M_2' \sin 2\omega t_r \quad (74a)$$

where

$$M_0' = \int_A N_{0r}' r^2 \sin \theta d\theta d\phi \quad (74b)$$

with equivalent expressions for M_1' and M_2' .

Since P must be the same in Equations 74a and 68a, they may be equated and the following relations found:

$$M_0 = M_0' \quad (75a)$$

$$M_1 = M_1' \cos 2kr - M_2' \sin 2kr \quad (75b)$$

$$M_2 = M_1' \sin 2kr + M_2' \cos 2kr \quad (75c)$$

$$M_1' = M_1 \cos 2kr + M_2 \sin 2kr \quad (75d)$$

$$M_2' = -M_1 \sin 2kr + M_2 \cos 2kr \quad (75e)$$

As Grimes (References 14 and 15) observed, Equation 68a [or Equation 74a] can be written in the form of Equation 42 or, its equivalent, Equation 50, or, more generally, Equation 54a and b. One way to do this is to set

$$P = M_0 + M_1 \cos 2\omega t + M_2 \sin 2\omega t = M_0 [1 + \cos(2\omega t - \delta)] + M_4 \sin(2\omega t - \delta) \quad (76)$$

and solve for M_4 and δ .

From Equation 76

$$M_1 \cos 2\omega t + M_2 \sin 2\omega t = M_0 [\cos \delta \cos 2\omega t + \sin \delta \sin 2\omega t] \\ + M_4 [\sin 2\omega t \cos \delta - \cos 2\omega t \sin \delta]$$

which reduces to the pair of equations,

$$M_1 = M_0 \cos \delta - M_4 \sin \delta \quad (77a)$$

$$M_2 = M_0 \sin \delta + M_4 \cos \delta \quad (77b)$$

Squaring Equation 77a and b and adding the result gives (References 14 and 15),

$$M_4 = \pm (M_1^2 + M_2^2 - M_0^2)^{1/2} \quad (78)$$

The simplest way to find δ is to divide Equation 77a by 77b resulting in

$$M_1 / M_2 = (M_0 \cos \delta - M_4 \sin \delta) / (M_0 \sin \delta + M_4 \cos \delta) \quad .$$

Factoring out $\cos \delta$ from the numerator and denominator on the right-hand side and solving for $\tan \delta$ gives

$$\tan \delta = (M_0 M_2 - M_1 M_4) / (M_0 M_1 + M_2 M_4) \quad (79)$$

Of course, if retarded time had been used instead, one would have

$$P = M_0 [1 + \cos(2\omega t_r - \delta')] + M_4' \sin(2\omega t_r - \delta') \quad (80)$$

where

$$M_4' = \pm \left(M_1'^2 + M_2'^2 - M_0^2 \right)^{1/2} \quad (81)$$

and

$$\tan \delta' = \left(M_0 M_2' - M_1' M_4' \right) / \left(M_0 M_1' + M_2' M_4' \right) . \quad (82)$$

Substituting Equation 75d and e into Equation 81 gives

$$\begin{aligned} M_4' &= \left(\pm M_1^2 \cos^2 2kr + M_2^2 \sin^2 2kr + 2M_1 M_2 \sin 2kr \cos 2kr + M_2^2 \cos^2 2kr \right. \\ &\quad \left. + M_1^2 \sin^2 2kr - 2M_1 M_2 \sin 2kr \cos 2kr - M_0^2 \right)^{1/2} \\ &= \pm \left(M_1^2 + M_2^2 - M_0^2 \right)^{1/2} = M_4 . \end{aligned} \quad (83)$$

This last result, taken in conjunction with Appendix B, shows that if $M_4 = \left(M_1^2 + M_2^2 - M_0^2 \right)^{1/2}$ is chosen, one of the two possible solutions of this general form, as discussed in the previous section results, whereas, if the minus root is chosen, the other solution will result. On the other hand, if one works with retarded time, the same two solutions would result. Using the plus minus subscript to indicate which one of the two subscripts in Equation 83 is chosen, one has

$$2\omega t_r - \delta_{\pm}' = 2\omega t - \delta_{\pm}$$

which, when solved, yields

$$\delta_{\pm}' = \delta_{\pm} - 2kr . \quad (84)$$

This can be shown by direct substitution.

Thus it makes no difference as to whether retarded time is used or not, the same two possible answers of this same general form result, although antenna fields are generally most easily and naturally written in terms of retarded time.

If Equation 76 is to be interpreted in terms of resistive and reactive power flow, only one of the two possible forms can be correct, although M_0 (for a one port, two terminal antenna) would be proportional to the radiation resistance and, without a priori knowledge as to which form is correct, M_4 could at least be taken as representing the absolute value of the radiation reactance.

Unfortunately, this interpretation (Reference 22) is on somewhat shaky physical grounds. The radiation resistance seems to represent a reasonable physical concept. Clearly the power radiated must be supplied by the signal source driving the antenna. One can find this power radiated by integrating the Poynting vector over the surface of any sphere surrounding the antenna. If one uses the complex Poynting vector, one takes (1/2) the real part to find the time average power radiated; if one uses the time domain form of the Poynting vector, one looks for that part that is independent of the radius of the sphere chosen. If the power radiated is given in terms of the square of the input current to the antenna terminals, then the coefficient of that square is the radiation resistance, and if there are no other losses, such as conduction losses in the antenna, this must represent the resistive part of the input impedance as seen at the antenna terminals.

The reactive power concept is not so clear. M_4 , the reactive power flow depends on the radius of the sphere chosen, with M_4 generally increasing with decreasing r , since the terms in \vec{E} and \vec{H} involved with the reactive power flow go as $1/r^2$, $1/r^3$, etc. The sphere that just encloses the antenna gives the largest reactive power flow and is closest to the antenna terminals. However, as seen in Figure 1, unless the antenna completely fills this minimum sphere, there remains considerable volume exterior to the antenna for energy storage and thus reactive power flow within the sphere but exterior to the antenna. Although it would probably have to be done numerically, the Poynting vector could be integrated over a surface more closely conforming to the antenna's physical shape. However, as discussed in Appendix A, the theoretical fields close to an antenna are of doubtful correctness in terms of the usually given electromagnetic solutions, and integrating using incorrect fields would likely add more error than correction.

In the case of Figure 5, a capacitively loaded dipole, the capacitors add reactance not included in the contributions of the external fields and thus there is always some reactance due to antenna geometry not included in M_4 .

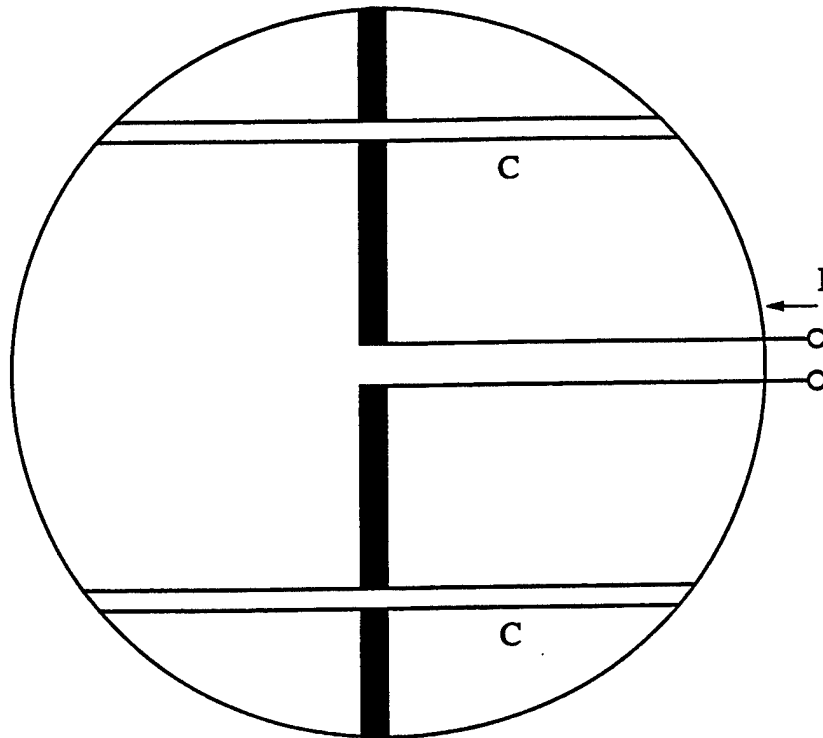

FIGURE 5. A Capacitively Loaded Dipole.

Regardless of these caveats on the use of M_4 to find radiation reactance, there seems to be an even bigger problem in recasting Equation 68a in the form of Equation 76 and interpreting it in terms of resistive and reactive power flow. To compare Equation 76 with the circuit analysis of the previous section requires that M_4 be real, which in turn requires that $M_1^2 + M_2^2 \geq M_0^2$ in Equation 78, otherwise M_4 is imaginary. In Reference 41 it is shown that for

$$\bar{E} = \pm j\eta\bar{H} \quad , \quad (85)$$

M_1 and M_2 are zero. Fields meeting this condition are known as Rumsey fields (References 41 and 42) and are not especially esoteric. Circularly polarized fields have this property.

If these radiation reactance (and resistance) concepts have problems, perhaps one should instead deal with the stored energy in the antenna fields, and from this find an antenna "Q," and an operating bandwidth. This approach will be discussed in the next section.

ANTENNA Q AND BANDWIDTH

The basic definition of the quality factor, Q, is given by (Reference 29)

$$Q = \frac{\omega(\text{energy stored in the circuit})}{\text{average power loss}} = \frac{\pi(\text{energy stored in the circuit})}{\text{energy loss per half cycle}} \quad (86)$$

Written out symbolically

$$Q = \omega U / W_L \quad (87)$$

The instantaneous energy stored in inductors and capacitors is found from the expressions

$$U_{Li} = LI^2 / 2 \quad (88a)$$

$$U_{Ci} = CV^2 / 2 \quad (88b)$$

where the subscript i indicates instantaneous value since I and V are generally functions of time.

The power dissipated in a resistance is

$$W_{Li} = IV = I^2 R = V^2 / R \quad (89)$$

Equation 86 specifies the "time average power loss." If the current through the resistor is of the physically realizable form

$$I = I_0 \cos \omega t \quad (90)$$

then

$$W_{Li} = RI_0^2 \cos^2 \omega t = RI_0^2 (1 + \cos 2\omega t) / 2 \quad (91)$$

The time average power loss is then

$$W_L = RI_0^2 / 2 \quad (92)$$

If the current is assumed to be in the physically non-realizable time harmonic form

$$I = I_0 e^{j\omega t} \quad (93)$$

and

$$W_L = R I I^* / 2 = R I_0^2 / 2 \quad , \quad (94)$$

the time average power loss has been found. One could recover W_{Li} from the time harmonic complex notation form by employing

$$W_{Li} = R(I I^* + \text{Re} I I) / 2 = (R/2) \text{Re}(I I^* + I I) \quad . \quad (95)$$

Running the same current through an inductor in series with this resistance, the stored energy is

$$U_{Li} = (L/2) I_0^2 \cos^2 \omega t = I_0^2 L (1 + \cos 2\omega t) / 4 \quad . \quad (96)$$

Applying this directly to Equation 87 results in a time dependent Q

$$Q_t = \frac{\omega L (1 + \cos 2\omega t)}{2R} \quad (97)$$

and while there is nothing wrong *a priori* with this, Q is usually given as a time independent quantity. Curiously enough, if one changes the definition of Q in Equation 86 in the denominator from being the time average power loss to instantaneous power loss, one would have

$$Q_{it} = \frac{\omega I_0^2 L (1 + \cos 2\omega t) / 4}{R I_0^2 (1 + \cos 2\omega t) / 2} = \omega L / 2R \quad (98)$$

which is time independent.

If U is defined to represent the peak energy stored, which is

$$U = I_0^2 L / 2 \quad (99)$$

one finds that

$$Q = (\omega I_0^2 L / 2) / (R I_0^2 / 2) = \omega L / R \quad (100)$$

This is the usual equation given for the Q of an inductor and a series resistance, and it is in this sense that many engineering texts define Q (Reference 29).

If one were to use the average energy stored rather than the peak energy, one would have

$$U_{La} = I_0^2 L / 4 \quad (101)$$

and

$$Q_a = \omega L / 2R \quad (102)$$

which is the same as in Equation 98.

It is this definition of Q that is used by other texts (Reference 43). Again, $Q_a = Q/2$, but this is not always the case and this will be discussed in detail later. In this case we also have $Q_u = Q_a$, but, in fact, Q_u is not generally independent of time as shall be seen.

Suppose the series inductor is replaced with a series capacitor. The time harmonic voltage across the capacitor is given by

$$V_c' = jX I_0 e^{j\omega t} = -j I_0 e^{j\omega t} / \omega C \quad (103)$$

so that

$$V_c = \text{Re}[V_c'] = (I_0 / \omega C) \sin \omega t \quad (104)$$

The energy stored in the capacitor is

$$U_{Ci} = (C I_0^2 / \omega^2 C^2) \sin^2 \omega t = (I_0^2 / 4 \omega^2 C) (1 - \cos 2\omega t) \quad (105)$$

The peak energy stored is

$$U_C = I_0^2 / 2 \omega^2 C \quad (106a)$$

and the time average energy is

$$U_{Ca} = I_0^2 / 4\omega^2 C \quad . \quad (106b)$$

In terms of peak energy, then, the Q is

$$Q = (I_0^2 / 2\omega^2 C) / (RI_0^2 / 2) = 1/\omega CR \quad (107)$$

which is the usual equation for the Q of a series capacitance and resistance (Reference 29).

In terms of the time average energy stored, the Q is

$$Q_a = 1/2\omega CR \quad . \quad (108)$$

Thus $Q_a = Q/2$, but again this is not always the case.

One can also see from Equations 100 and 107 that in these two cases, $Q = |X|/R$, i.e., the absolute value of the reactance divided by the series resistance. Again, this is not true in general.

In this case, it is important to note that Q_{tt} is given by

$$Q_{tt} = \left[I_0^2 (1 - \cos 2\omega t) / 4\omega C \right] / \left[RI_0^2 (1 + \cos 2\omega t) / 2 \right] = \tan^2 \omega t / 2\omega CR \quad . \quad (109)$$

From this, it appears that Q_{tt} might not be a useful concept, since it ranges with time from zero to infinity.

Turning to the series RLC circuit of Figure 3, one could, of course, directly use the previous equations by using the current as given in Equation 90. However, Figure 3 shows an applied voltage of $V_0 \cos \omega t$, so it is instructive to use Figure 3 directly with the given applied voltage, rather than replace it with the current of Equation 90. The answer will be the same.

The time harmonic current is given by

$$\begin{aligned}
 I' &= V'/Z = V_0 e^{j\omega t} / [R + j(\omega L - 1/\omega C)] \\
 &= V_0 e^{j\omega t} \exp(-j \tan^{-1} X/R) / (R^2 + X^2)^{1/2}
 \end{aligned}$$

or

$$I' = (V_0 / |Z|) \exp[j(\omega t - \phi)] \quad (110)$$

where

$$Z = (R^2 + X^2)^{1/2} \text{ and } \phi = \tan^{-1} X/R .$$

The time dependent current is then

$$I = (V_0 / |Z|) \cos(\omega t - \phi) . \quad (111)$$

The energy stored in the inductance is then

$$U_{Li} = (LV_0^2 / 4|Z|^2) [1 + \cos 2(\omega t - \phi)] \quad (112)$$

while the power lost in the resistance is

$$W_{Li} = (V_0^2 R / 2|Z|^2) [1 + \cos 2(\omega t - \phi)] \quad (113a)$$

with a time average power loss of

$$W_L = V_0^2 R / 2|Z|^2 . \quad (113b)$$

The time harmonic voltage across the capacitor is

$$V_c' = (jX_c V_0 / |Z|) \exp j(\omega t - \phi) = (V_0 / \omega C |Z|) \exp[j(\omega t - \phi - \pi/2)] \quad (114a)$$

and the time dependent voltage is

$$V_c = (V_0 / \omega C |Z|) \cos(\omega t - \phi - \pi/2) = (V_0 / \omega C |Z|) \sin(\omega t - \phi) \quad (114b)$$

The energy stored in the capacitor is thus

$$U_{Ci} = (CV_0^2 / 2\omega^2 C^2 |Z|^2) [1 - \cos 2(\omega t - \phi)] \quad (115)$$

and the total stored energy is

$$U_i = U_{Li} + U_{Ci} = (V_0^2 / 4|Z|^2) \left\{ L[1 + \cos 2(\omega t - \phi)] + (1/\omega^2 C)[1 - \cos 2(\omega t - \phi)] \right\}$$

or

$$U_i = (V_0^2 / 4\omega |Z|^2) [\omega L + 1/\omega C + (\omega L - 1/\omega C) \cos 2(\omega t - \phi)] \quad (116)$$

The time average stored energy is then

$$U_a = (V_0^2 / 4\omega |Z|^2) (\omega L + 1/\omega C) \quad (117)$$

The peak stored energy, however, depends on whether $\omega L > 1/\omega C$ or not. Thus

$$U = (V_0^2 / 2\omega |Z|^2) \begin{cases} \omega L & ; \quad \omega L \geq 1/\omega C \text{ or } \omega \geq \omega_0 \\ 1/\omega C & ; \quad \omega L \leq 1/\omega C \text{ or } \omega \leq \omega_0 \end{cases} \quad (118)$$

where the resonant frequency is given by

$$\omega_0 = 1/\sqrt{LC} \quad (119)$$

Using the peak energy definition of "Q," then

$$Q = \omega L / R \quad ; \quad \omega \geq \omega_0 \quad (120a)$$

$$Q = 1/\omega CR \quad ; \quad \omega \leq \omega_0 \quad (120b)$$

On the other hand, the average Q is given by

$$Q_a = \omega L/2R + 1/2\omega CR \quad (121)$$

At very high frequencies ($\omega \gg \omega_0$) where $1/2\omega CR$ is negligible, the average Q_a is $\omega L/2R$ or one half the peak energy Q as given in Equation 120a.

At very low frequencies ($\omega \ll \omega_0$) where $\omega L/2R$ can be neglected, Q_a goes to $1/2\omega CR$, also one half the peak energy Q .

On the other hand, at resonance when $\omega = \omega_0$, the peak energy Q is

$$Q_0 = L/R\sqrt{LC} = (1/R)\sqrt{L/C} \quad (122)$$

while

$$Q_{a0} = L/2R\sqrt{LC} + \sqrt{LC/2CR} = (1/R)\sqrt{L/C} = Q_0 \quad (123)$$

Thus, in a series resonant circuit, Q_a ranges from $Q/2$ to Q . It can be shown that these limits hold for any circuit, starting with the premise that stored energy is always positive, ($U_i \geq 0$), and that it consists of a time dependent part that varies as 2ω and a time independent part.

It follows that a stored energy versus time plot must look like Figure 6, which represents a sinusoidal waveform plus a dc component such that the function is always positive. From this figure, if $U_{\min} = 0$, then $U_a = U/2$ and $Q_a = Q/2$, as is the case for a series resistor and capacitor.

On the other hand, if $U - U_{\min}$ is small (the time varying part is small), $U_a \approx U$ and $Q_a = Q$. At resonance in the series resonant circuit, the time varying part of the stored energy is zero (the total reactance is zero) and $Q_a = Q$. Thus it is clear that

$$Q/2 \leq Q_a \leq Q \quad (124)$$

for all circuits.

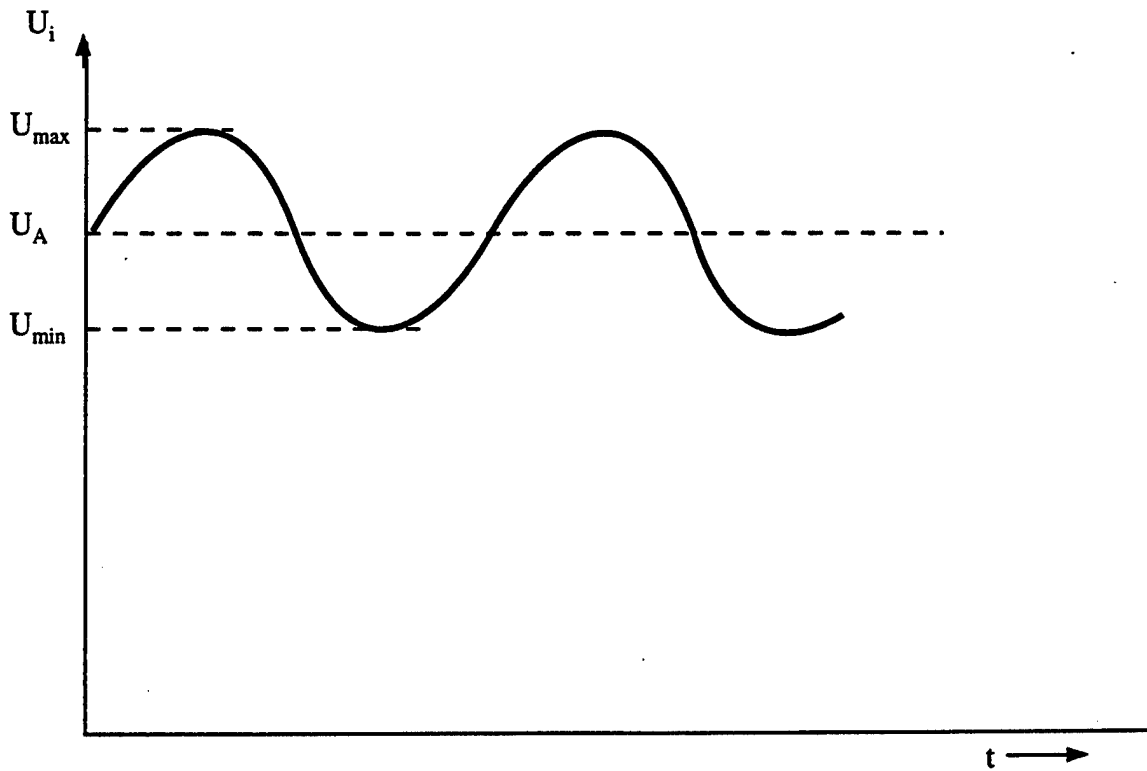

FIGURE 6. A Typical Stored Energy as a Function of Time Plot.

So far the examples covered have been series circuits; parallel circuits must be discussed also. Consider a capacitor, C , in parallel with a resistance, R , across which is applied a voltage $V_0 \cos \omega t$. The instantaneous energy stored is

$$U_{Ci} = (CV_0^2/4)(1 + \cos 2\omega t)$$

while the power loss is

$$W_{Li} = R(V_0^2 \cos^2 \omega t / R^2) = V_0^2(1 + \cos 2\omega t)/2R .$$

Then, in terms of peak energy stored, the Q is

$$Q = (\omega CV_0^2/2)/(V_0^2/2R) = \omega CR \quad (125)$$

while in terms of time average energy stored it is

$$Q_a = \frac{\omega CR}{2} . \quad (126)$$

Thus the peak energy Q is the inverse of the series RC case, but the time average Q_a is still one half of the Q as calculated from the peak energy.

Considering the case of an inductance, L , in parallel with a resistance, R , the current through L with the same applied voltage is

$$I_L = (V_0 / \omega L) \sin \omega t \quad (127)$$

and the instantaneous stored energy is

$$U_{Li} = (L/2) (V_0^2 / \omega^2 L^2) \sin^2 \omega t = (V_0^2 / 4\omega^2 L) (1 - \cos 2\omega t) \quad (128)$$

The Q is

$$Q = R / \omega L \quad (129)$$

i.e., the inverse of Equation 100 for the series RL case. The time average Q becomes

$$Q_a = R / 2\omega L \quad (130)$$

Consider the complete parallel RLC circuit of Figure 4. The total stored energy is

$$U_i = U_{Li} + U_{Ci} = V_0^2 [1/\omega L + \omega C + (\omega C - 1/\omega L) \cos 2\omega t] / 4\omega \quad (131)$$

The time average stored energy is

$$U_a = V_0^2 (\omega C + 1/\omega L) / 4\omega \quad (132)$$

while the peak stored energy is

$$U = \begin{cases} V_0^2 C / 2 & ; \omega C \geq 1/\omega L \\ V_0^2 C / 2\omega^2 L & ; \omega C \leq 1/\omega L \end{cases} \quad (133)$$

Thus

$$Q_a = R(\omega C + 1/\omega L)/2 \quad (134a)$$

and

$$Q = \begin{cases} \omega CR & ; \quad \omega C \geq 1/\omega L \\ R/\omega L & ; \quad \omega C \leq 1/\omega L \end{cases} \quad (134b)$$

In this case, after comparison with Equations 120a, 120b, and 121, it is seen that the time average Q_a is not the inverse of the series case, rather L and C are interchanged. Again, at resonance, $Q_a = Q$ and Q_a is in accord, as it must be, with Equation 124.

Reference 43 gives two equations for finding the Q of a circuit. They are

$$Q_a = (\omega/2R)\partial X/\partial\omega \quad , \quad (135a)$$

$$Q_a = (\omega/2G)\partial B/\partial\omega \quad . \quad (135b)$$

We have added the subscript a to Q_a because it will now be shown that the application of either of these equations leads to the time average Q_a . Consider the series resonant circuit of Figure 3. Now

$$Q_a = (\omega/2R)\partial(\omega L - 1/\omega C)/\partial\omega = (\omega L + 1/\omega C)/2R$$

which is of course, Equation 121.

Now apply Equation 135b to the parallel circuit of Figure 4. Then

$$Q_a = (\omega R/2)\partial(\omega C - 1/\omega L)/\partial\omega = R(\omega C + 1/\omega L)/2$$

which is Equation 134a.

Equations 135a and b may have been assumed to be universal but, in fact, Equation 135a applies only to series circuits and 135b only to parallel circuits.

To show this, consider the circuit of Figure 3. The input impedance is

$$Z = R + j(\omega L - 1/\omega C) = R + jX \quad (136a)$$

and the input admittance is

$$Y = G + jB = 1/Z = (R - jX)/(R^2 + X^2). \quad (136b)$$

Applying Equation 135b,

$$Q_a = (\omega/2G) \partial \left[-X/(R^2 + X^2) \right] / \partial \omega$$

or

$$Q_a = \left[\omega(X^2 - R^2)/2R(X^2 + R^2) \right] \partial X / \partial \omega$$

and

$$Q_a = [(\omega L + 1/\omega C)/2R] \left[(X^2 - R^2)/(X^2 + R^2) \right].$$

This is not the same as Equation 121, but rather is modified by the factor $(X^2 - R^2)/(X^2 + R^2)$. For ω very small, this factor goes to unity since $1/\omega C \gg R$ and $1/\omega C \gg \omega L$ and this equation would give a correct value for Q_a . Also, for ω very large, the same is true. Otherwise this expression is incorrect, although, curiously, as $\omega \rightarrow \omega_0$, $X \rightarrow 0$, and the above equation reduces to

$$Q_a = -(\omega L + 1/\omega C)/2R$$

i.e., the negative of the correct value. The same procedure of finding the input impedance of the parallel circuit of Figure 4 and applying Equation 135a yields similar results.

Any series circuit consisting of N_1 resistors, N_2 inductors, and N_3 capacitors can be replaced with Figure 3 where R is the sum of the resistors, L the sum of the inductors, and the capacitance C can be found from

$$1/C = 1/C_1 + 1/C_2 + \dots + 1/C_{N_3}. \quad (137)$$

A parallel circuit containing N_1 resistors, N_2 inductors, and N_3 capacitors can be represented by Figure 4 where C is the sum of the capacitances, and

$$1/R = 1/R_1 + 1/R_2 + \dots + 1/R_{N_1} \quad (138a)$$

with

$$1/L = 1/L_1 + 1/L_2 + \dots + 1/L_{N2} \quad . \quad (138b)$$

It follows that Equation 135a applies strictly only to series circuits and Equation 135b to parallel circuits and neither is exact for general series-parallel circuits.

It is common to give the Q in terms of a resonant frequency divided by a 3-dB bandwidth, i.e.,

$$Q = f_0 / \Delta f_0 \quad . \quad (139)$$

In fact this expression is used so much that it is easy to subconsciously accept it as a fundamental definition of Q, instead of in terms of the stored energy and the power loss per cycle. Upon reflection, however, it is immediately clear that this expression is somewhat meaningless in terms of, say, a simple series R and L circuit where there is no resonance. Thus Equation 139 cannot be applied to every circuit, only those that resonate. It follows that if an antenna is operated in a frequency region where it is not self resonant, then the "Q" of this antenna can be treated in terms of Equation 87, i.e., stored energy and power loss, but not directly in terms of Equation 139. That is, given the Q and the operating frequency, one cannot use Equation 139 to find the bandpass, since the antenna is not resonant. Antennas that are small with respect to a wavelength are usually in this situation (References 44 through 47).

If it is assumed, for now, that resonance means a real input impedance (the reactance goes to zero at f_0), then one can talk about the "bandwidth" only in terms of the antenna plus its matching circuit, or at least in terms of the antenna plus whatever reactance is added externally to cancel out the antenna reactance. For example, suppose that around the operating frequency, f_0 , our particular antenna can be well represented by a frequency independent resistance in series with a frequency independent capacitance, i.e., R and C of Figure 3. The "Q_p" of this combination is given at resonance by Equation 107 with $\omega = \omega_0$. Adding a series inductor, L, so that $L = 1/\omega_0^2 C$, the input impedance at f_0 is just R. It should be noted that the antenna is still not "matched" in the classical sense, unless it happens that $R = Z_0$, the characteristic impedance of the generator being used to feed the antenna.

The current through the series RLC circuit of Figure 3 in time harmonic form is

$$I_C = V_C / [R + j(\omega L - 1/\omega C)] \quad (140)$$

where $V = \text{Re}[V_c]$.

The time average power loss in the resistor is given by Equation 94 and is

$$W_L = V_0^2 R / 2 [R^2 + (\omega L - 1/\omega C)^2] \quad . \quad (141)$$

At resonance the time average power loss is

$$W_{L0} = V_0^2 / 2R \quad . \quad (142)$$

Since the time average power loss decreases for frequencies on either side of ω_0 , one can look for the 3 dB frequencies, ω_1 and ω_2 , where the power dissipated is down by a factor of 2, i.e.,

$$W_{L1,2} / W_{L0} = \left\{ V_0^2 R / 2 \left[R^2 + (\omega_{1,2} L - 1 / \omega_{1,2} C)^2 \right] \right\} (2R / V_0^2) = 1/2$$

or

$$R^2 / \left[R^2 + (\omega_{1,2} L - 1 / \omega_{1,2} C)^2 \right] = 1/2$$

which results in

$$(\omega_{1,2} L - 1 / \omega_{1,2} C)^2 = R^2 \quad . \quad (143)$$

The resistance, R, is always positive so that in taking the square root of both sides,

$$\omega_2 L - 1 / \omega_2 C = R \quad ; \quad \omega_2 > \omega_0 \quad (144a)$$

and

$$1 / \omega_1 C - \omega_1 L = R \quad ; \quad 1 / \omega_1 C > \omega_1 L \quad \text{or} \quad \omega_1 > \omega_0 \quad . \quad (144b)$$

Equations 144a and 144b can be solved explicitly for ω_1 and ω_2 giving

$$\omega_2 = \left[RC + \sqrt{R^2 C^2 + 4LC} \right] / 2LC \quad (145a)$$

and

$$\omega_1 = \left[-RC + \sqrt{R^2 C^2 + 4LC} \right] / 2LC \quad . \quad (145b)$$

If

$$\Delta\omega = \omega_2 - \omega_1 = R/L \quad , \quad (146)$$

then

$$\omega_0 / \Delta\omega = f_0 / \Delta f = \omega_0 L / R = Q_p \quad (147)$$

where Equation 147 is also Equation 139.

Since no approximations have been made, this expression is exact for a series resonant circuit.

It is interesting to note that

$$\Delta\omega_2 = \omega_2 - \omega_0 = \omega_0 \left[\omega_0 RC + \sqrt{\omega_0^2 R^2 C^2 + 4} - 2 \right] / 2 \quad (148a)$$

while

$$\Delta\omega_1 = \omega_0 - \omega_1 = \omega_0 \left[\omega_0 RC - \sqrt{\omega_0^2 R^2 C^2 + 4} + 2 \right] / 2 \quad (148b)$$

Thus the resonance curve is not symmetrical in ω , since $\Delta\omega_2 \neq \Delta\omega_1$. In fact

$$\Delta\omega_2 \geq \Delta\omega_1 \quad (149)$$

because

$$\sqrt{\omega_0^2 R^2 C^2 + 4} \geq 2 \quad (150)$$

For high Q circuits where R is small enough, $\Delta\omega_1$ will become virtually equal to $\Delta\omega_2$, however.

Of course the Q involved is for the whole series RLC circuit, however, the antenna was assumed to be a series R and C with a matching coil to make the impedance real at the operating frequency/resonance. Since both the capacitor and inductor store energy, one can quickly see that the total energy stored might be greater than for the antenna alone. It can be seen that adding any further reactive elements for, say, the purpose of

matching the input impedance to a characteristic impedance (or any other purpose for that matter) might raise the Q , and, by implication narrow the bandwidth Δf in Equations 148 and 140. In fact, it can be shown, given a circuit with some Q , that the addition of reactive elements in either series or parallel carries the following condition on the resultant Q_r ;

$$Q_r \geq Q \quad . \quad (151)$$

This proof is carried out in Appendix D.

In the example just covered, the Q_r of the matched circuit is $1/\omega CR$ for frequencies below or equal to the resonant frequency, i.e.,

$$Q_r = Q \quad ; \quad f \leq f_0 \quad (152a)$$

and the addition of the inductance leaves the Q unchanged. For frequencies above resonance, however,

$$Q_r = \omega L / R = \omega / \omega_0^2 RC = \omega Q_0 / \omega_0 = \omega^2 Q / \omega_0^2 \quad . \quad (152b)$$

That is, Q_r is greater than the Q of the antenna alone. Of course it can be argued that near the operating frequency, f_0 , the Q doesn't change much for a high Q circuit because f/f_0 must be near unity to stay within the 3 dB bandwidth.

In summary, if an antenna could be faithfully represented by frequency independent series resistance and capacitance (and the authors know of no such antenna), the Q as determined from the radiated power and stored energy could be used to determine the operating bandwidth and frequency with a series inductance for matching. Unfortunately, this has not been shown to be the case in general. For example, a parallel inductance could be chosen as a matching element for the hypothetical series R and C antenna in Figure 7.

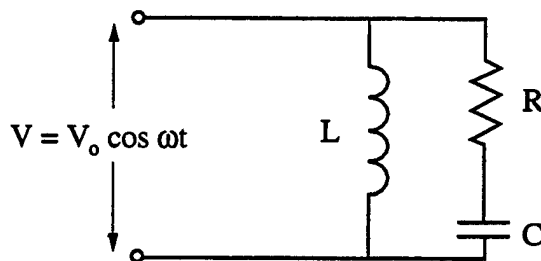

FIGURE 7. Using a Parallel Inductance as a Matching Element for a Hypothetical Series $R C$ Antenna.

Before dealing with this case, one needs to derive the equivalent of Equation 148 for a parallel resonant circuit. While it seems that this should be straightforward, there are conceptual difficulties to overcome. In using the power loss of Figure 3 at resonance and the 3 dB frequencies to define the operating bandwidth, there was no difficulty because the current I through the (radiation) resistance had an inverse relation with the impedance, Z . However, if Figure 4 is used as drawn, maintaining a constant voltage $V_0 \cos \omega t$ across the circuit, the power lost (radiated) will be independent of frequency as $V_0^2 \cos^2 \omega t / R$.

Typically in portraying experimental work the signal source is shown as a voltage generator in series with a series impedance Z_0 so that actual circuits look like Figures 8a and 8b. Figure 8a can be treated exactly as Figure 3 with R replaced by $R_T = R + Z_0$, as long as Z_0 is real, and the loaded Q_L becomes;

$$Q_L = \omega L / R_T \quad ; \quad f \geq f_0 \quad (153a)$$

$$Q_L = 1 / \omega C R_T \quad ; \quad f \leq f_0 \quad (153b)$$

Figure 8b is different. The characteristic impedance Z_0 absorbs some of the generator output, but as Z_0 goes to zero the power lost (radiated) in the (radiation) resistance, R , becomes independent of frequency. One could replace the voltage generator with a current generator having a characteristic conductance across the generator, but while this simplifies the mathematics of the situation because parallel conductances add, the problem remains. The two representations are exactly equivalent as is shown in Appendix E.

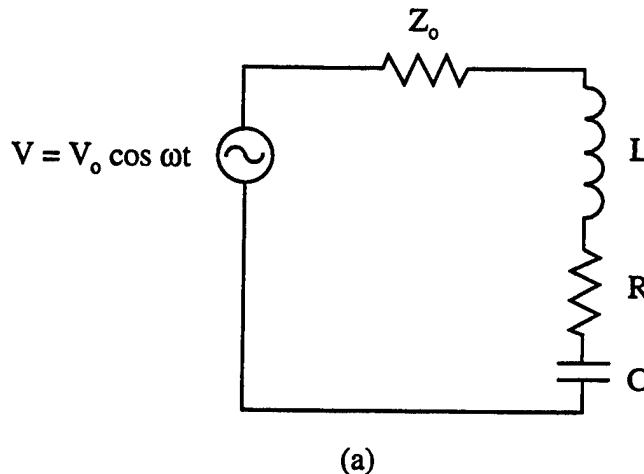
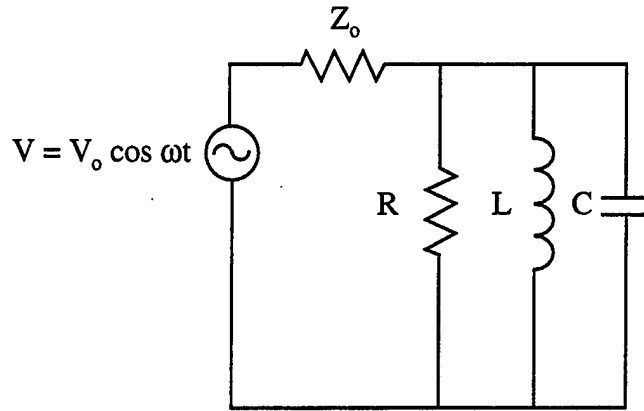

FIGURE 8(a). Series RLC Circuit With Signal Source Shown as a Voltage Generator in Series With Impedance, Z_0 .



(b)

FIGURE 8 (b) Parallel RLC Circuit With Signal Source Shown as a Voltage Generator in Series With Impedance, Z_0 .

Another approach is to examine Figure 3 and observe that $|Z|$ is a minimum at resonance, rising to infinity as $f \rightarrow 0$ and $f \rightarrow \infty$. The admittance, $|Y|$, then has a typical resonant shape with a peak at $f = f_0$.

Looking at the absolute value of the admittance,

$$|Y| = 1 / \left[R^2 + (\omega L - 1/\omega C)^2 \right]^{1/2} \quad (154a)$$

then

$$Y_0 = 1/R \quad (154b)$$

and at the 3 dB points

$$|Y_{1,2}|/|Y_0| = R / \left[R^2 + (\omega_{1,2}L - 1/\omega_{1,2}C)^2 \right]^{1/2} = 1/\sqrt{2} \quad (154c)$$

which results in the equation

$$(\omega_{1,2}L - 1/\omega_{1,2}C)^2 = R^2$$

which is, of course, just Equation 143 and the solution must be Equation 147 as previously found.

In Figure 4 it is the absolute value of the impedance that is maximum at resonance and goes to zero as $f \rightarrow 0$ and $f \rightarrow \infty$. The admittance of Figure 4 is just

$$Y = G + j(\omega C - 1/\omega L) \quad (155)$$

where $G = 1/R$. Then

$$Z_0 = 1/G \quad (156)$$

so that the 3 dB relation is

$$|Z_{1,2}|/|Z_0| = G / \left[G^2 + (\omega_{1,2}C - 1/\omega_{1,2}L)^2 \right]^{1/2} = 1/\sqrt{2} \quad (157)$$

resulting in the equation

$$(\omega_{1,2}C - 1/\omega_{1,2}L)^2 = G^2 \quad (158)$$

Equation 158 is of the same form as Equation 143 with C and L interchanged and R replaced by G. Thus the solution must be given by Equations 146 and 147 with this interchange and substitution, i.e.

$$\Delta\omega = G/C \quad (159)$$

and

$$\omega_o / \Delta\omega = \omega_o C / G = \omega_o CR = Q_p \quad (160)$$

A parallel resonant circuit has the same relation between Q and the resonant frequency divided by the 3-dB bandwidth as the series resonant circuit.

Of course not all circuits are wholly series or wholly parallel but may be some combination of series and parallel elements.

Figure 7 is a simple example of such a circuit. If one cares to analyze this circuit, one will find it far more algebraically "messy" than a simple series or parallel RLC circuit. If the series R and C represent some "mythical antenna," one will find the concepts of matching and bandwidth considerably more complicated.

CONCLUSION

This report has been devoted to examining some of the basic ideas and assumptions that are involved in the theoretical analysis of small antennas. Poynting's theorems in both the time and frequency domain cases have been derived and the conditions under which they are mathematically applicable carefully examined. The relationships with stored energy, both time dependent and time average, were derived.

It was shown that the concept of integrating Poynting's vector over a surface surrounding an antenna to find the power flow, although valid, is not generally the same as or even a part of Poynting's theorem.

Resistive and reactive power flow into circuits was examined and compared with the power flow across a closed surface surrounding an antenna. It was pointed out that while using this approach to find the input or radiation resistance of a single port antenna can often be justified, the situation as regards finding antenna input reactance is on very shaky ground indeed.

Because small antennas are frequently referred to in terms of "Q" and bandwidth, these concepts were explored for series and parallel circuits. Even here much room for misinterpretation and misconceptions was found. Indeed it was found that all of the references quoted here dealing with limitations on the performance of small antennas (References 1 through 24) could be criticized on the grounds of misapplying the fundamentals covered in this report.

However, much more remains to be covered, i.e., to find the theoretical limits on antennas that are small with respect to a wavelength. Some of this work has actually been done in the form of notes and derivations but space, time, and money constraints prevent its inclusion in this report. Further reports are planned dealing with such subjects as some particular antenna configurations that could show performance much improved over the Wheeler limit (Reference 2), Rumsey antennas (Reference 42), and new applications of spherical harmonics and multipoles to small antenna analysis.

REFERENCES

1. L. J. Chu. "Physical Limitations of Omni-Directional Antennas," *J. Appl. Phys.*, Vol. 19 (December 1948), pp. 1163-1175.
2. H. A. Wheeler. "Fundamental Limitations of Small Antennas," *Proc. IRE*, Vol. 35 (December 1947), pp. 1479-1484.
3. R. F. Harrington. "Effect of Antenna Size on Gain, Bandwidth, and Efficiency," *J. Res. Nat. Bur. Stds.D*, Vol. 64D (January 1960), pp. 1-12.
4. L. Solymar. "Maximum Gain of a Line Source Antenna if the Distribution Function is a Finite Fourier Series," *IRE Trans. Antennas Propag.*, Vol. AP-6, (July 1958), pp. 215-219.
5. R. F. Harrington. "On the Gain and Beamwidth of Directional Antennas," *IRE Trans. Antennas Propag.*, Vol. AP-6 (April 1958), p. 219.
6. R. L. Fante. "Maximum Possible Gain for an Arbitrary Ideal Antenna With Specified Quality Factor," *IEEE Trans. Antennas Propag.*, Vol. 40 (December 1992), pp. 1586-1588.
7. J. S. McClean. "A Re-Examination of the Fundamental Limits on the Radiation Q of Electrically Small Antennas," *IEEE Trans. Antennas Propag.*, Vol. 44 (May 1996), pp. 672-676.
8. H. A. Wheeler. "The Radiansphere Around a Small Antenna," *Proc. IRE*, Vol. 47 (1959), pp. 1325-1331.
9. R. E. Collin and S. Rothschild. "Evaluation of Antenna Q," *IEEE Trans. Antennas Propag.*, Vol. AP-12 (January 1964), pp. 23-27.
10. R. C. Hansen. "Fundamental Limitations in Antennas," *Proc. IEEE*, Vol. 69 (February 1981), pp. 170-182.
11. R. L. Fante. "Quality Factor of General Ideal Antenna," *IEEE Trans. Antennas Propag.*, Vol. 17 (March 1969), pp. 151-155.
12. D. M. Grimes. "Radiant Energy Exchange by Small Objects Using Continuum Fields," *J. App. Phys.*, Vol. 49 (August 1978), p. 4341.
13. D. M. Grimes. "Biconical Receiving Antenna," *J. Math. Phys.*, Vol. 23, No. 5 (May 1982), p. 897.
14. D. M. Grimes. "Quantum Theory and Classical, Nonlinear Electronics," *Physica D*, Vol. 20D (1986), p. 285.

15. D. M. Grimes. "Quantum Theory: The Classical Theory of Nonlinear Electromagnetics," *Physica D*, Vol. 32D (1988), p. 1.
16. C. A. Grimes and D. M. Grimes. "A Small Antenna With Aerospace Applications," *1991 IEEE Aerospace Appl. Conference Digest*, Crested Butte, CO (Paper No. 3) (1991).
17. D. M. Grimes, V. Badii, and K. Tomiyama. "Characterization of Biconical Transmitting Antennas," *Radio Science*, Vol. 26 (January 1991), p. 101.
18. S. - H. Kim, D. M. Grimes, and C. A. Grimes. "Electrically Small Mixed Modal (MMA) Array for Aerospace Applications," in the *1992 IEEE Aerospace Appl. Conference Digest*, Snowmass, Colo., February 1992. P. 19.
19. D. M. Grimes, "Atomic Theory and Radiative Transfer on the Basis of Nonlinear, Classical Electrodynamics," A. Lakhtakia, ed., in *Essays on the Formal Aspects of Electromagnetic Theory*, World Scientific Press, Singapore (1993). Pp. 310-356.
20. D. M. Grimes and C. A. Grimes. "Poynting's Theorem and Time-Harmonic Radiators," *1994 IEEE Aerospace Appl. Conference Proceedings*, Vail, Colo., February 1994.
21. D. M. Grimes and C. A. Grimes. "A Classical Field Theory of Photons," T. W. Barrett and D. M. Grimes, eds., in *Advanced Electromagnetism: Foundations, Theory, and Applications*, World Scientific Press, Singapore (1995).
22. D. M. Grimes and C. A. Grimes. "Bandwidth and Q of Antennas Radiating TE and TM modes," *IEEE Trans. Electromagn. Compat.*, Vol. 32 (1995), p. 217.
23. C. A. Grimes and D. M. Grimes. "Small Antenna Configurations: Implementation Promises and Problems," in *IEEE Electromagnetic Compat. Conference Proceedings*, Atlanta, Georgia, August 1995.
24. D. M. Grimes and C. A. Grimes. "Does the Complex Poynting Theorem Adequately Address Reactive Power? or Efficient Electrically Small Antennas," *Speculations in Science and Technology*, January 1996.
25. J. D. Jackson. *Classical Electrodynamics*. New York, Wiley, 1975.
26. C. A. Balanis. *Antenna Theory*. New York, Wiley, 1982.
27. R. S. Elliott. *Antenna Theory and Design*. Englewood Cliffs, New Jersey, Prentice-Hall, 1981.
28. W. L. Stutzman and G. A. Thiele. *Antenna Theory and Design*. New York, Wiley, 1981.
29. S. Ramo, J. R. Whinnery, and T. Van Duzer. *Fields and Waves in Communication Electronics*. New York, Wiley, 1965.
30. R. E. Collin and F. J. Zucker. *Antenna Theory*. New York, McGraw-Hill, 1969. Vols. 1 and 2.

31. R. W. P. King. *The Theory of Linear Antennas*. Cambridge, Mass., Harvard University Press, 1956.
32. R. Plonsey and R. E. Collin. *Principles and Applications of Electromagnetic Fields*. New York, McGraw-Hill, 1961.
33. S. A. Schelkunoff. *Advanced Antenna Theory*. New York, Wiley, 1952.
34. W. K. Panofsky and M. Philips. *Classical Electricity and Magnetism*. Reading, Mass., Addison-Wesley, 1962.
35. J. A. Stratton. *Electromagnetic Theory*. New York, McGraw-Hill, 1941.
36. J. D. Kraus. *Antennas*. New York, McGraw-Hill, 1950.
37. J. M. H. Olmsted. *Advanced Calculus*. (New York, Century-Crofts, 1961.
38. H. F. Davis. *Introduction to Vector Analysis*. Boston, Mass., Allyn and Bacon, 1967.
39. H. Mott. *Polarization in Antennas and Radar*. New York, Wiley, 1986.
40. Naval Air Warfare Center Weapons Division. Active Impedance Matching for Superdirective, Supergain HTS Antenna Arrays, by D. J. White, D. R. Bowling, and P. L. Overfelt. China Lake, Calif., NAWCWPNS, March 1996. 129 pp. (NAWCWPNS TP 8249, publication UNCLASSIFIED.)
41. P. L. Overfelt, D. J. White, and D. R. Bowling, "The Poynting Vector When $\mathbf{E} = i \eta \mathbf{H}$," NAWCWPNS Memo 3900, 474180D/009, March 1996.
42. V. H. Rumsey. *Frequency Independent Antennas*. New York, Academic, 1966.
43. C. G. Montgomery, R. H. Dicke, and E. M. Purcell. *Principles of Microwave Circuits*. New York, McGraw-Hill, 1948.
44. P. L. Overfelt. "Electric Lines of Force of an Electrically Small Dipole-Loop Antenna Array," *IEEE Trans. Antennas Propag.*, Vol. AP-46 (March 1998), pp. 451-456.
45. Naval Air Warfare Center Weapons Center. *Electric Lines of Force of an Electrically Small Mixed Mode Array Antenna*, by P. L. Overfelt. China Lake, Calif., NAWCWPNS, October 1997. 25 pp. (NAWCWPNS TP 8372, publication UNCLASSIFIED.)
46. _____. A Collocated Magnetic Loop, Electric Dipole Array Antenna (Preliminary Results) by P. L. Overfelt, D. R. Bowling, and D. J. White. China Lake, Calif., NAWCWPNS, September 1994. 32 pp. (NAWCWPNS TP 8212, publication UNCLASSIFIED.)
47. P. L. Overfelt, D. J. White, and D. R. Bowling. "Theoretical and Practical Aspects of Achieving Wideband Compact Antenna Elements and Arrays," presented at the ONR *Wideband RF Science and Technology Workshop*, Orlando, Florida, April 8-11, 1997.

Appendix A.

**THE 'EXACT' DIPOLE ANTENNA AND ITS
TANGENTIAL BOUNDARY CONDITION**

Consider the dipole antenna of Figure A-1, constructed of conducting wire with a diameter of a , a gap width g , and a total length L . If the wire is made of a good conductor, if $L \gg a$, the gap width g is very small with respect to a wavelength, and L is on the order of a wavelength, it is usually assumed (Reference A-1) that Figure A-2 is a good model with which to represent Figure A-1, so that the radiated fields can be reasonably found and calculated.

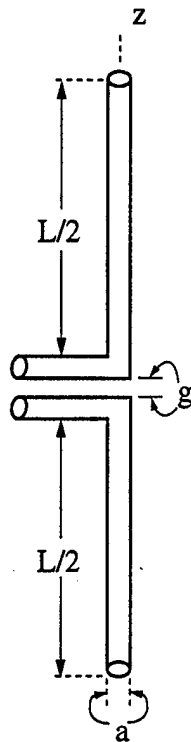

FIGURE A-1. Wire Dipole Antenna.

The model in Figure A-2 could be said to be benign in the sense that increasing the conductivity of the wire, decreasing the wire diameter a , and the gap width g , albeit this limits the permissible driving voltage, should enable the real antenna to arbitrarily approach the model.

A quite general solution to Maxwell's equations can be found using a vector potential formulation. For the time harmonic case, this vector potential is given by,

$$\bar{A} = \frac{\mu}{4\pi} \iiint_V \frac{\bar{J}(\bar{r}')}{|\bar{r} - \bar{r}'|} e^{-jk|\bar{r} - \bar{r}'|} dV' \quad (A-1)$$

For the line source of Figure A-2, this reduces to:

$$A_z = \int_{-L/2}^{L/2} I(z') \frac{e^{-jkR}}{R} dz' \quad (A-2)$$

To solve the dipole problem it is customary, at this point, to assume a current distribution, $I(z')$. Typically a sinusoidal current distribution of the form

$$I(z') = I_0 \sin[k(L/2 - |z'|)] \quad ; \quad -L/2 \leq z' \leq L/2 \quad (A-3)$$

is assumed.

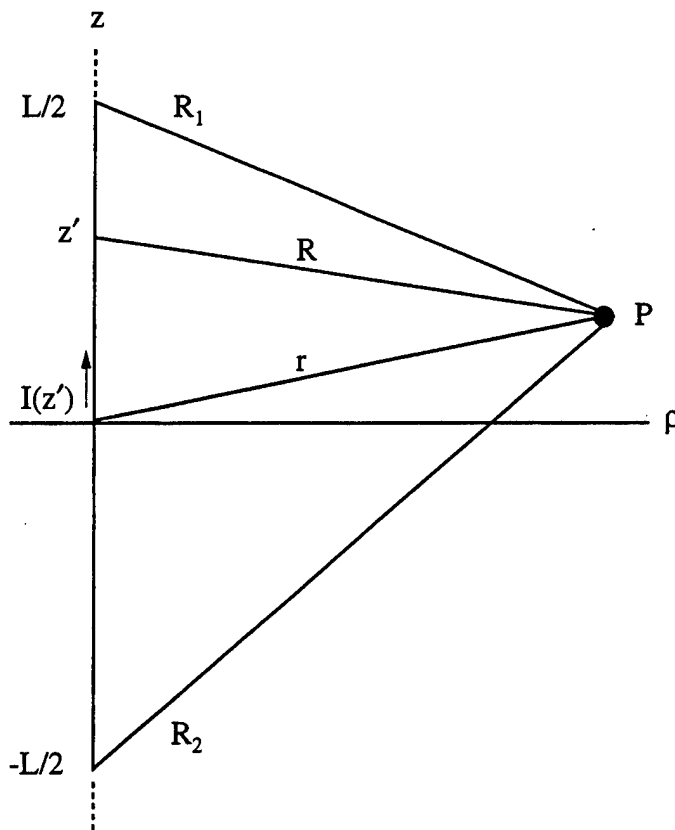

FIGURE A-2. Model for Dipole Antenna.

This current distribution is an assumption but it seems a reasonable one, with the characteristics of a standing wave and going to zero at the dipole ends. In any case, the radiation characteristics of a dipole do not appear to be overly sensitive to the form of the assumed current distribution (References A-2 and A-3), with assumed rectangular, sinusoidal, and triangular distributions giving very similar results.

If Equation A-3 is substituted into Equation A-2 and utilizes

$$\bar{H} = \frac{1}{\mu} \nabla \times \bar{A} \quad (\text{A-4a})$$

which is in this case

$$H_{\phi} = -\frac{1}{\mu} \frac{\partial A_z}{\partial \rho} \quad (\text{A-4b})$$

one obtains terms under the integral that are exact differentials (Reference A-1), and carrying out the integration, the magnetic field is

$$H_{\phi} = \frac{-I_0}{4j\pi\rho} \left[e^{-jkR_1} + e^{-jkR_2} - 2\cos(kL/2)e^{-jkr} \right] \quad (\text{A-5})$$

The nonzero electric field components can be found directly from this by taking the curl of \bar{H} resulting in,

$$E_{\rho} = -\frac{jZ_0 I_0}{4\pi\rho} \left[(z-L/2)e^{-jkR_1} / R_1 + (z+L/2)e^{-jkR_2} / R_2 \right. \\ \left. - 2z\cos(kL/2)e^{-jkr} / r \right] \quad (\text{A-6a})$$

$$E_z = \frac{-jZ_0 I_0}{4\pi} \left[e^{-jkR_1} / R_1 + e^{-jkR_2} / R_2 - 2\cos(kL/2)e^{-jkr} / r \right] \quad (\text{A-6b})$$

Within the limits of the model and the assumed current distribution, these appear to be exact expressions for the fields everywhere exterior to the line source. It is straightforward to transform these fields from cylindrical to spherical coordinates and make the assumption $r \gg L$ and find the usual far field expressions for such an antenna, i.e.,

$$H_{\phi} = \frac{jI_0 e^{-jkr}}{2\pi r} \frac{\cos(kL \cos \theta)/2 - \cos(kL)/2}{\sin \theta} , \quad (\text{A-7a})$$

$$E_{\theta} = Z_0 H_{\phi} \quad (\text{A-7b})$$

Since no dispute of these results has been found in the literature, it is assumed that Equation A-7a and b represent a close approximation to experimental results in the far field, and with the emphasis on near-field measurements in these past several years, one might expect that Equations A-5 and A-6a and b have been experimentally verified to within some fairly close proximity to the antenna surface.

Nonetheless, Equation A-6b possesses a quality which, upon discovery, must make any engineer who started his career in metallic waveguides feel at least uneasy. Namely, the tangential electric field does not go to zero at the antenna surface, or even anything close.

This is most easily demonstrated by the example of a half-wave dipole where $L = \lambda/2$. It then follows that $\cos(kL/2) = \cos(2\rho/4\lambda) = \cos(\pi/2) = 0$. Next, choose an observation point $P(\rho, z) = P(\rho, L/4) = P(\rho, \lambda/8)$. Choosing $z = 0$ would simplify the math, but, for $\rho = 0$, this corresponds to the gap on the real antenna and enforcing tangential $E = 0$ there might be considered unreasonable.

For the chosen observation point, P, R_1 and R_2 become

$$R_1^2 = (z - L/2)^2 + \rho^2 = (\lambda/8 - \lambda/4)^2 + \rho^2 = \lambda^2/64 + \rho^2 \quad (\text{A-8a})$$

$$R_2^2 = (z + L/2)^2 + \rho^2 = 9\lambda^2/64 + \rho^2 \quad (\text{A-8b})$$

$$r^2 = z^2 + \rho^2 = \lambda^2/64 + \rho^2 = R_1^2 \quad (\text{A-8c})$$

Equation A-6b for E_z is then

$$E_z = \frac{-jZ_0 I_0}{4\pi} \left\{ \left(\lambda^2/64 + \rho^2 \right)^{-1/2} \exp \left[-jk \left(\lambda^2/64 + \rho^2 \right)^{1/2} \right] \right. \\ \left. + \left(9\lambda^2/64 + \rho^2 \right)^{-1/2} \exp \left[-jk \left(9\lambda^2/64 + \rho^2 \right)^{1/2} \right] \right\} . \quad (\text{A-9})$$

If one now takes the limit as ρ goes to zero, which ought to be tangential E for a very skinny dipole, there results

$$\lim_{\rho \rightarrow 0} E_z = 2.10834 Z_0 I_0 / \pi \lambda \quad (A-10)$$

It could reasonably be argued that even though tangential E must go very close to zero for the real antenna, with finite conductivity at $\rho = a/2$ in Figure A-1, it is unreasonable to expect this for the line source in Figure A-2. For if the resistance of the wire antenna is

$$R_r = a^2 / 4L\sigma \quad (A-11)$$

then $\lim R_r$, as $a \rightarrow 0$, $\sigma \rightarrow \infty$ is indeterminate

This might be a good argument, but one would expect that tangential E ought to at least have a local minimum somewhere around $\rho = 0$. This doesn't seem to happen. Tangential E is actually maximum at $\rho = 0$, and decreases monotonically after that.

To show this one can take

$$\begin{aligned} |E_z|^2 \left(\pi^2 \lambda^2 / 4 Z_0^2 I_0^2 \right) = F = 1 / (1 + 64 f^2) + 1 / (9 + 64 f^2) \\ + \frac{2 \cos \left(\pi \left(\sqrt{9 + 64 f^2} - \sqrt{1 + 64 f^2} \right) / 4 \right)}{\sqrt{1 + 64 f^2} \sqrt{9 + 64 f^2}} \end{aligned} \quad (A-12)$$

where $f = \rho / \lambda$.

One could take dF/df and show that it is always less than, or equal to, zero and, therefore, that F, and hence $|E_z|$ decreases monotonically as one moves along ρ away from the antenna. It is easier, however, just to plot F versus f and this is done in Figure A-3, out to $f = 0.5$ (a half wavelength). F is maximum at $\rho = 0$ and decreases monotonically with $f(\rho)$.

Clearly, tangential E does not only not go to zero at the antenna for the model of Figure A-2 and the assumed sinusoidal current distribution, it doesn't even go to a minimum.

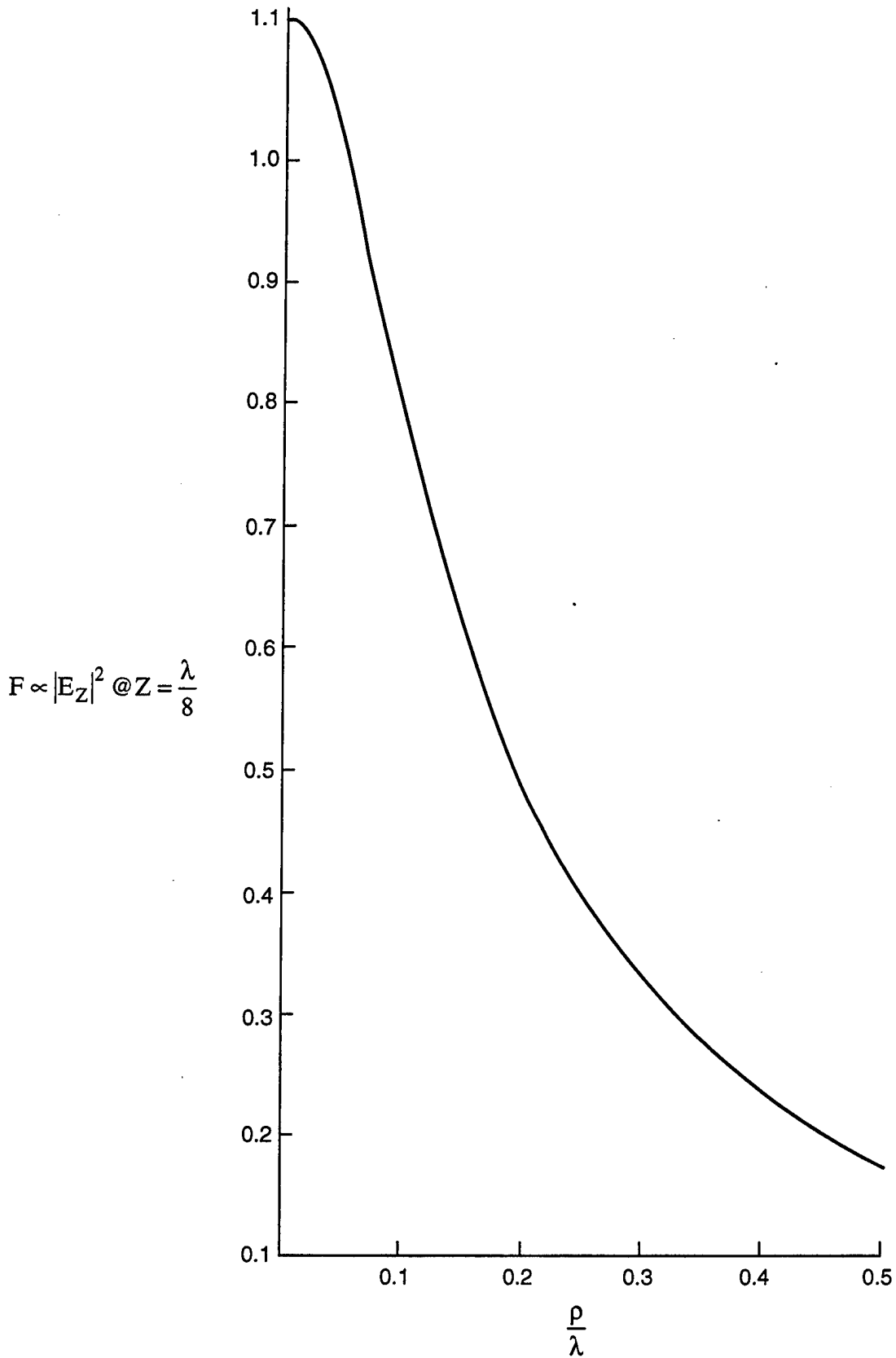

FIGURE A-3. Plot of F (Which is Proportional to the Magnitude of E_z Squared) Versus f .

REFERENCES

- A-1. H. Mott. *Polarization in Antennas and Radar*. New York, Wiley, 1986. Pp. 23-27.
- A-2. P. L. Overfelt. "An Exact Method of Integration for Vector Potentials of Thin Dipole Antennas," *IEEE Trans. Antennas Propag.*, Vol. AP-35 (April 1987), pp. 442-444.
- A-3. Naval Weapons Center. *Near Field Vector Potentials for Thin Dipole Antennas*, by P. L. Overfelt. China Lake, Calif., NWC, September 1985. (NWC TP 6645, publication UNCLASSIFIED.)

Appendix B

ALTERNATE FORMS OF THE CIRCUIT POWER FLOW EQUATION

Suppose we have

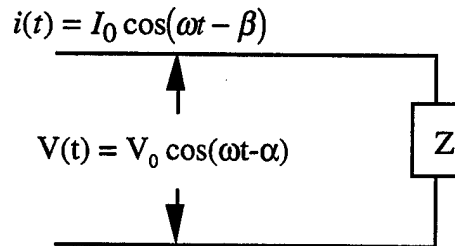

The power flow in the above is given by

$$P(t) = V(t)i(t) \quad (B-1)$$

Of course V_0 and I_0 are not independent, being related by the magnitude of the impedance. The phases α and β are not independent either, their difference being a function of the ratio X/R when $Z = R + jX$.

Carrying out the operation implied in B-1

$$P(t) = I_0 V_0 \cos(\omega t - \beta) \cos(\omega t - \alpha)$$

or

$$P(t) = \frac{I_0 V_0}{2} [\cos(\alpha - \beta) + \cos(2\omega t - \alpha - \beta)] \quad (B-2)$$

by using a trigonometric identity, B-2 can be rewritten as

$$P(t) = \frac{I_0 V_0}{2} [\cos(\alpha - \beta) + \cos(2\omega t - 2\beta + \beta - \alpha)] \quad (B-3)$$

or

$$P(t) = \frac{I_0 V_0}{2} [\cos(\alpha - \beta) + \cos(\beta - \alpha) \cos(2\omega t - 2\beta) - \sin(\beta - \alpha) \sin(2\omega t - 2\beta)]$$

and finally

$$P(t) = \frac{I_0 V_0}{2} [\cos(\alpha - \beta)(1 + \cos(2\omega t - 2\beta)) + \sin(\alpha - \beta) \sin(2\omega t - 2\beta)] \quad (B-4)$$

Of course it could also be written as

$$P(t) = \frac{I_0 V_0}{2} [\cos(\alpha - \beta) + \cos(2\omega t - 2\alpha + \alpha - \beta)] \quad ,$$

leading to

$$P(t) = \frac{I_0 V_0}{2} [\cos(\alpha - \beta)(1 + \cos(2\omega t - 2\alpha)) - \sin(\alpha - \beta) \sin(2\omega t - 2\alpha)] \quad (B-5)$$

As seen in the main body of the report the resistance R is related to $\cos(\alpha - \beta)$ and the reactance X to the $\sin(\alpha - \beta)$.

The exact relation can be found by observing that

$$I(t) = \mathbf{Re} \frac{V_0 e^{j\omega t} e^{-j\alpha}}{R + jX} = \frac{V_0}{|Z|} \cos(\omega t - \alpha - \tan^{-1}(X/R)) \quad (B-6)$$

Thus

$$I_0 = \frac{V_0}{|Z|} \text{ and } \beta = \alpha + \tan^{-1}(X/R) \quad (B-7)$$

Then

$$\cos(\alpha - \beta) = \cos(-\tan^{-1}(X/R)) = \cos(\tan^{-1}(X/R)) = \frac{R}{|Z|} \quad (B-8a)$$

and

$$\sin(\alpha - \beta) = \sin\left(-\tan^{-1}(X/R)\right) = -\sin\left(\tan^{-1}(X/R)\right) = -\frac{X}{|Z|} \quad (\text{B-8b})$$

Both B-4 and B-5, being identities, correctly represent the power flow, however only one of the two, as explained in the main body of the text can be correctly broken up so that the $1 + \cos(2\omega t - \phi)$ represents resistive power flow (where ϕ is either 2β or 2α) and $\sin(2\omega t - \phi)$ represents reactive power flow. Which form is correct requires *a priori* knowledge about the circuit, which is not directly found in the integration of the Poynting vector. Nonetheless the multiplier of $1 + \cos(2\omega t - \phi)$ is proportional to R , so R can be found unambiguously regardless of whether the proper expression is chosen. However, the multiplier of $\sin(2\omega t - \phi)$ is only proportional to $|X|$, so that only $|X|$ could be, in any case, inferred from the integration over the time domain Poynting vector. In any case B-4 and B-5 are of the general form

$$P = A[1 + \cos(2\omega t - \phi)] + B\sin(2\omega t - \phi) \quad (\text{B-9})$$

Is it possible to write either of these (Equation B-9) in the form

$$P = C[1 + \cos(2\omega t - \theta)] + D\sin(2\omega t - \theta) \quad (\text{B-10})$$

where C , D , or θ are different than A , B , or ϕ ? If so then further ambiguities as to the value of R and X (actually $|X|$) would be introduced upon the integration of the time domain Poynting vector.

Set B-10 equal to B-9 obtaining

$$C[1 + \cos(2\omega t - \theta)] + D\sin(2\omega t - \theta) = A[1 + \cos(2\omega t - \phi)] + B\sin(2\omega t - \phi) \quad (\text{B-11})$$

where A , B , and ϕ are known, C , D , and θ are unknown.

Rewriting B-11 as

$$\begin{aligned} C + C\cos\theta\cos 2\omega t + C\sin\theta\sin 2\omega t + D\cos\theta\sin 2\omega t - D\sin\theta\cos 2\omega t \\ = A + A\cos\phi\cos 2\omega t + A\sin\phi\sin 2\omega t + B\cos\phi\sin 2\omega t - B\sin\phi\cos 2\omega t \end{aligned}$$

or

$$C + (C \cos \theta - D \sin \theta) \cos 2\omega t + (C \sin \theta + D \cos \theta) \sin 2\omega t \quad (\text{B-12})$$

$$= A + (A \cos \phi - B \sin \phi) \cos 2\omega t + (A \sin \phi + B \cos \phi) \sin 2\omega t$$

To be true for all values of t one must have

$$C = A \quad (\text{B-13})$$

This can easily be seen by setting $2\omega t = \pi$, then $2\omega t = -\pi$, resulting in the equations

$$C + C \cos \theta - D \sin \theta = A + A \cos \phi - B \sin \phi$$

and

$$C - C \cos \theta + D \sin \theta = A - A \cos \phi + B \sin \phi$$

Adding these equations gives $C = A$.

Thus B-10 is constrained to the form

$$P = A[1 + \cos(2\omega t - \theta)] + D \sin(2\omega t - \theta) \quad (\text{B-14})$$

Equation B-12 becomes

$$(A \cos \theta - D \sin \theta) \cos 2\omega t + (A \sin \theta + D \cos \theta) \sin 2\omega t$$

$$= (A \cos \phi - B \sin \phi) \cos 2\omega t + (A \sin \phi + B \cos \phi) \sin 2\omega t$$

To be true for all values of t one must have

$$A \cos \theta - D \sin \theta = A \cos \phi - B \sin \phi \quad (\text{B-15a})$$

$$A \sin \theta + D \cos \theta = A \sin \phi + B \cos \phi \quad (\text{B-15b})$$

where A , B , and ϕ are assumed known and D and θ unknown.

To eliminate "D" from B-15a and B-15b, multiply through by $\cos \theta$ and $\sin \theta$ resulting in

$$A \cos^2 \theta - D \sin \theta \cos \theta = A \cos \phi \cos \theta - B \sin \phi \cos \theta$$

and

$$A \sin^2 \theta + D \sin \theta \cos \theta = A \sin \phi \sin \theta + B \cos \phi \sin \theta$$

Adding the above, one obtains

$$A = A(\cos \phi \cos \theta + \sin \phi \sin \theta) + B(\cos \phi \sin \theta - \sin \phi \cos \theta)$$

or

$$A = A \cos(\theta - \phi) + B \sin(\theta - \phi) \quad (\text{B-16})$$

Equation B-16 can be solved as follows. Rewrite it as

$$A = \frac{A}{\sqrt{1 + \tan^2(\theta + \phi)}} + \frac{B \tan(\theta - \phi)}{\sqrt{1 + \tan^2(\theta - \phi)}}$$

or

$$A \sqrt{1 + \tan^2(\theta - \phi)} = A + B \tan(\theta - \phi)$$

Squaring both sides and collecting terms, one obtains

$$(A^2 - B^2) \tan^2(\theta - \phi) - 2AB \tan(\theta - \phi) = 0 \quad (\text{B-17})$$

Thus either

$$\tan(\theta - \phi) = 0 \quad (\text{B-18a})$$

or

$$\tan(\theta - \phi) = \frac{2AB}{A^2 - B^2} \quad (\text{B-18b})$$

and the solutions to B-18a are

$$\theta = \phi \quad , \quad (B-19a)$$

$$\theta = \phi + \pi \quad , \quad (B-19b)$$

$$\theta = \phi - \pi \quad . \quad (B-19c)$$

Substitution of B-19a into B-15a and 15b leads immediately to the trivial solution

$$D = B \quad . \quad (B-20)$$

Substitution of B-19b into B-15a and 15b gives

$$-A \cos \phi + D \sin \phi = A \cos \phi - B \sin \phi \quad (B-21a)$$

and

$$-A \sin \phi - D \cos \phi = A \sin \phi - B \cos \phi \quad . \quad (B-21b)$$

Multiplying the first equation by $\sin \phi$ and the second by $\cos \phi$ and subtracting gives

$$D = -B \quad . \quad (B-22)$$

However substitution of this solution back into B-21a and B-21b results in $A = -A$ which is not allowed unless $A = 0$ which is not a general case.

Substituting B-19c into B-15a and B-15b gives

$$-A \cos \phi + D \sin \phi = A \cos \phi - B \sin \phi \quad (B-23a)$$

$$-A \sin \phi - D \cos \phi = A \sin \phi + B \cos \phi \quad . \quad (B-23b)$$

Again, multiplying the top equation by $\sin \phi$, the bottom by $\cos \phi$ and subtracting results in

$$D = -B, \quad (\text{B-22})$$

but with the same result, $A = -A$, i.e., $A = 0$. Thus B-19b and B-19c are not general solutions.

This leaves B-18b as the only other possible general solution. In fact since it is known from B-4 and B-5 there are two such solutions, it is the other general solution. However, to find D in terms of B by direct substitution of B-18b into B-15a and B-15b is algebraically messy. It is easier to return to B-15a and B-15b and rewrite them as

$$A(\cos\theta - \cos\phi) = D\sin\theta - B\sin\phi \quad (\text{B-24a})$$

and

$$A(\sin\theta - \sin\phi) = B\cos\phi - D\cos\theta \quad (\text{B-24b})$$

Eliminating A by multiplying the top equation by $(\sin\theta - \sin\phi)$ and the bottom equation by $(\cos\theta - \cos\phi)$ and subtracting gives

$$D(1 - \sin\theta\sin\phi - \cos\theta\cos\phi) + B(1 - \sin\theta\sin\phi - \cos\theta\cos\phi) = 0$$

Either

$$D = -B \quad (\text{B-25})$$

or

$$1 - \sin\theta\sin\phi - \cos\theta\cos\phi = 1 - \cos(\theta - \phi) = 0 \quad (\text{B-26})$$

Equation B-26 is the (trivial) solution already given in B-19a

Therefore B-25 corresponds to the solution given in B-18b. This can be verified by substitution of B-25 and B-18b into B-15a and B-15b.

Thus, it follows that Equation B-9, corresponding to Equation B-4, can be rewritten as

$$P = A \left[1 + \cos \left(2\omega t - \phi - \tan^{-1} \frac{2AB}{A^2 - B^2} \right) \right] - B \sin \left(2\omega t - \phi - \tan^{-1} \frac{2AB}{A^2 - B^2} \right) \quad (\text{B-27})$$

which must then correspond to Equation B-5, and these are the only two possibilities for this term.

There are, however, two more forms of the power flow equation that might tempt one to break them up into separate resistive and reactive power flow components incorrectly. Consider Equation B-9. Let

$$\phi_1 = \phi + \pi \quad (B-28)$$

Then

$$P = A[1 + \cos(2\omega t - \phi_1 + \pi)] + B\sin(2\omega t - \phi_1 + \pi)$$

or

$$P = A[1 - \cos(2\omega t - \phi_1)] - B\sin(2\omega t - \phi_1) \quad (B-29)$$

If one lets $\phi_2 = \phi - \pi$, ϕ_2 and ϕ_1 differ by 2π and are, in effect, the same angle. The same is essentially true for $\phi_2 = \pi - \phi$.

However, it follows that since Equation B-10 can be written as

$$P = A[1 + \cos(2\omega t - \theta)] - B\sin(2\omega t - \theta) \quad ,$$

by setting

$$\theta_1 = \theta + \pi \quad (B-30)$$

it can also be written as

$$P = A[1 - \cos(2\omega t - \theta_1)] + B\sin(2\omega t - \theta_1) \quad (B-31)$$

Thus, from the preceding, the circuit power flow equation can be written in the separate forms

$$P = A[1 + \cos(2\omega t - \phi)] + B\sin(2\omega t - \phi) \quad (B-32)$$

$$P = A[1 + \cos(2\omega t - \theta)] - B\sin(2\omega t - \theta) \quad (\text{B-33})$$

$$P = A[1 - \cos(2\omega t - \phi_1)] - B\sin(2\omega t - \phi_1) \quad (\text{B-34})$$

$$P = A[1 - \cos(2\omega t - \theta_1)] + B\sin(2\omega t - \theta_1) \quad (\text{B-35})$$

where

$$\phi_1 = \phi + \pi, \theta_1 = \theta + \pi, \text{ and } \theta = \phi + \tan^{-1} \frac{2AB}{A^2 - B^2} \quad (\text{B-36})$$

All of these equations are correct for the total power flow, but only one (either B-9 or B-10) can generally be broken into separate resistive and reactive power flows.

Appendix C

**THE RELATIONS BETWEEN THE FIELD COMPONENTS
IN STRAIGHT AND RETARDED TIME**

Electromagnetic fields in the complex time harmonic form can be written as

$$\bar{E} = \bar{E}_0 e^{j\omega t} = (\bar{E}_0' - j\bar{E}_0'') e^{j\omega t} \quad (C-1)$$

From this the time domain (sinusoidal) physical forms can be found by taking the real part of \bar{E} (or \bar{H} as the case may be).

However, antenna fields usually come in the form

$$\bar{E} = \bar{E}_1 e^{-jkr} e^{j\omega t} = (\bar{E}_1' - j\bar{E}_1'') e^{j\omega t} \quad (C-2)$$

where

$$t_r = t - r/c \quad (C-3)$$

Thus it is simpler and more logical to write the antenna fields, both time harmonic and time domain, in terms of retarded time.

The relations between \bar{E}_0 and \bar{E}_1 are simply derived, starting with Equation C-1, i.e.,

$$\bar{E} = \bar{E}_0 e^{jkr} e^{-jkr} e^{j\omega t} = \bar{E}_0 e^{jkr} e^{j\omega t_r} = \bar{E}_1 e^{j\omega t_r} \quad (C-4)$$

Thus

$$\bar{E}_0 e^{jkr} = \bar{E}_1 \quad (C-5)$$

or

$$\left(\bar{E}_0' - j\bar{E}_0''\right)(\cos kr + j \sin kr) = \bar{E}_1' - j\bar{E}_1'' \quad (\text{C-6})$$

and from this

$$\bar{E}_1' = \bar{E}_0' \cos kr + \bar{E}_0'' \sin kr \quad (\text{C-7a})$$

$$\bar{E}_1'' = \bar{E}_0'' \cos kr - \bar{E}_0' \sin kr \quad (\text{C-7b})$$

Going the other way

$$\bar{E} = \bar{E}_1 e^{j\alpha r} = \bar{E}_1 e^{-jkr} e^{j\alpha r} = \bar{E}_0 e^{j\alpha r} \quad (\text{C-8})$$

or

$$\left(\bar{E}_1' - j\bar{E}_1''\right)(\cos kr - j \sin kr) = \bar{E}_0' - j\bar{E}_0'' \quad (\text{C-9})$$

and

$$\bar{E}_0' = \bar{E}_1' \cos kr - \bar{E}_1'' \sin kr \quad (\text{C-10a})$$

$$\bar{E}_0'' = \bar{E}_1'' \cos kr + \bar{E}_1' \sin kr \quad (\text{C-10b})$$

A like set of equations can be derived for the magnetic fields.

Appendix D

**EFFECT ON Q OF ADDING PURELY REACTIVE
ELEMENTS TO ANY CIRCUIT**

Suppose there is a box (antenna) containing some combination of resistances, capacitances, and inductances in any series, parallel, or series parallel arrangement. This box has some known Q.

Suppose there is some other box containing only lossless capacitors and inductors in any arrangement which is to be attached to the first box for some purpose, matching at some frequency.

There are two ways to attach this box, i.e.,

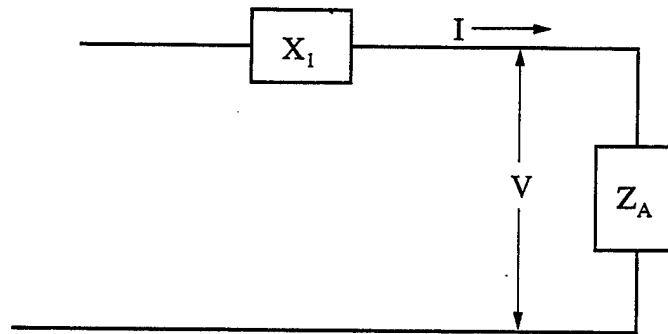

and

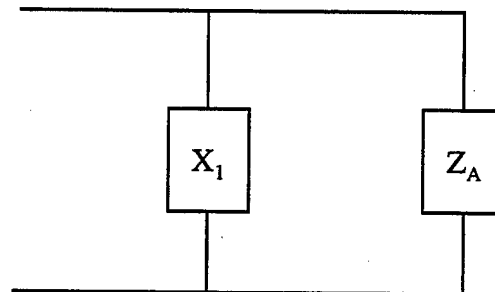

The Q of Z_A was originally determined by applying some voltage V across it and driving some current I through it. Where black box X_1 is joined to Z_A in either the series or parallel sense, V and I might change if one drives the circuit with the same generator although they must retain the same relative phase and amplitude since

$$V = Z_A I .$$

(D-1)

The power flow into A is determined from

$$P = VI = Z_A I^2 = V^2/Z_A \quad (D-2)$$

After the addition of circuit X_1 , in either series or parallel, the exact same V across Z_A , and hence the same I can be maintained by changes in the magnitude, phase and/or characteristic impedance or admittance of the driving generator. For example consider a worst case scenario where circuit X_1 approaches a short and is placed in parallel with circuit Z_A .

If the initial measurement is carried out as

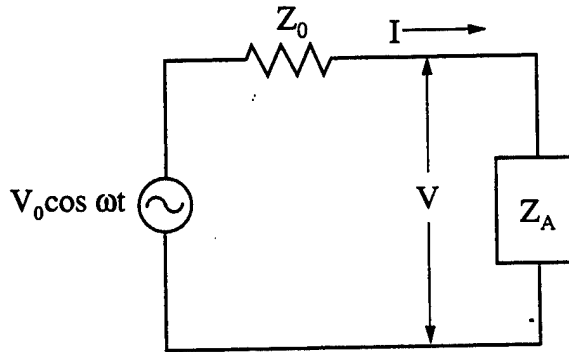

then the same V and I , can be maintained as follows:

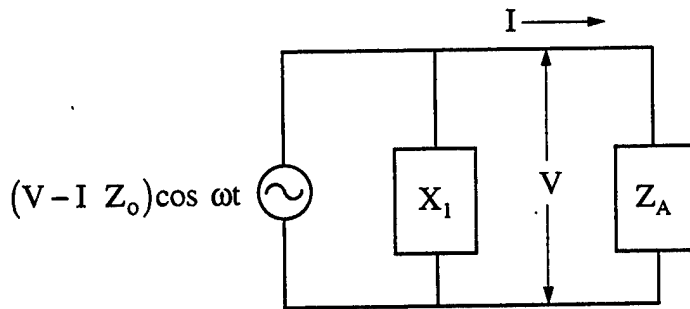

It is postulated that this is done. Now

$$Q = \frac{\omega V}{W_L} \quad (D-3)$$

where W_L is the time average power loss and V is the peak stored reactive energy. W_L is unchanged by the addition of Z_1 if V and I are unchanged since Z_1 is lossless. The reactive energy stored in Z_A is also unchanged and is of the form

$$V_A(t) = K_{A1} + K_{A2} \cos(2\omega t - \phi_A) \quad (D-4)$$

There is a time independent part, K_{A1} , which must be positive, and a time dependent part, $K_{A2} \cos(2\omega t - \phi_A)$. K_{A2} can also be written as a positive number by adding or subtracting π from ϕ_A . That is if $\phi_A = \phi_A' + \pi$, then

$$\cos(2\omega t - \phi_A) = \cos(2\omega t - \phi_A' - \pi) = -\cos(2\omega t - \phi_A') \quad (D-5)$$

It will be assumed that this operation is always carried out so that K_{A2} is positive.

Because the stored energy can never be negative, one must have

$$K_{A1} \geq K_{A2} \quad (D-6)$$

The Q of circuit A alone is thus

$$Q_0 = \frac{\omega(K_{A1} + K_{A2})}{W_L} \quad (D-7)$$

When circuit Z_1 is added, whether it is in series or parallel, and the driving generator is changed to maintain the same V and I across and through circuit A, it will also have stored energy of the form

$$V_1(t) = K_{11} + K_{12} \cos(2\omega t - \phi_1) \quad (D-8)$$

where

$$K_{11} \geq K_{12} \quad (D-9)$$

Again, ϕ_1 is chosen by adding π so that K_{12} is positive.

The total time dependent stored energy is thus

$$\begin{aligned} U(t) &= U_1(t) + U_A(t) = K_1 + K_2 \cos(2\omega t - \phi) \\ &= K_{A1} + K_{11} + K_{A2} \cos(2\omega t - \phi_A) + K_{12} \cos(2\omega t - \phi_1) \end{aligned} \quad (D-10)$$

By breaking D-10 into $\cos 2\omega t$ and $\sin 2\omega t$, one finds that

$$K_1 = K_{A1} + K_{11} \quad , \quad (D-11a)$$

$$K_{A2} \cos \phi_A + K_{12} \cos \phi_1 = K_2 \cos \phi \quad , \quad (D-11b)$$

$$K_{A2} \sin \phi_A + K_{12} \sin \phi_1 = K_2 \sin \phi \quad . \quad (D-11c)$$

It follows that

$$\tan \phi = \frac{K_{A2} \sin \phi_A + K_{12} \sin \phi_1}{K_{A2} \cos \phi_A + K_{12} \cos \phi_1} \quad . \quad (D-12)$$

Squaring Equation D-11b and D-11c and adding gives

$$K_2^2 = K_{A2}^2 + K_{12}^2 + 2K_{A2}K_{12} \cos(\phi_A - \phi_1) \quad . \quad (D-13)$$

Thus the total time dependent stored energy is

$$U(t) = K_{A1} + K_{11} + \sqrt{K_{A2}^2 + K_{12}^2 + 2K_{A2}K_{12} \cos(\phi_A - \phi_1)} \cos(2\omega t - \phi) \quad . \quad (D-14)$$

The peak energy stored is

$$U = K_{A1} + K_{11} + \sqrt{K_{A2}^2 + K_{12}^2 + 2K_{A2}K_{12} \cos(\phi_A - \phi_1)} \quad (D-15)$$

and the resultant Q is

$$Q = \frac{\omega \left(K_{A1} + K_{11} + \sqrt{K_{A2}^2 + K_{12}^2 + 2K_{A2}K_{12} \cos(\phi_A - \phi_1)} \right)}{W_L} \quad . \quad (D-16)$$

Clearly

$$Q \geq Q_0 \quad , \quad (D-17)$$

or the total Q is minimum in those cases where

$$\phi_A - \phi_1 = \pi \quad . \quad (D-18)$$

Then

$$Q = \frac{\omega(K_{A1} + K_{11} + K_{A2} - K_{12})}{W_L} \quad ; \quad K_{A2} \geq K_{12} \quad (D-19a)$$

or

$$Q = \frac{\omega(K_{A1} + K_{11} + K_{12} - K_{A2})}{W_L} \quad ; \quad K_{12} \geq K_{A2} \quad (D-19b)$$

If $K_{12} = K_{11}$, as it does for a simple capacitor or inductor, Equation D-19a becomes

$$Q = \frac{\omega(K_{A1} + K_{A2})}{W_L} = Q_0 \quad (D-20)$$

which is the case for the simple series RLC circuit below resonance as discussed in the body of this report.

Note that if Equation D-19b happens to be the case and $K_{A2} = K_{A1}$, then

$$Q = \frac{\omega(K_{11} + K_{12})}{W_L} \geq Q_0 \quad (D-21)$$

since

$$K_{11} \geq K_{12} \geq K_{A2} = K_{A1} \quad (D-22)$$

It has been shown that $Q \geq Q_0$ for any two terminal circuit when any lossless circuit is added to it externally. One could add further circuits (lossless) in any fashion such as below.

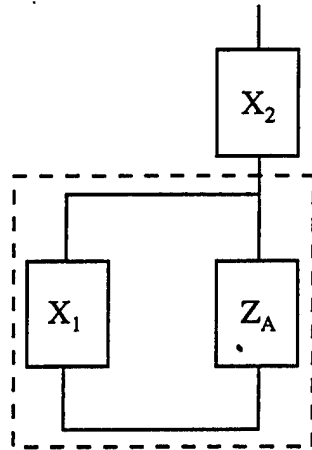

It is readily seen that by treating X_1 and Z_A in the dotted box as the original circuit, adding X_2 in this case (in series), results in a new circuit with a Q equal to or greater than that of the original circuit.

Thus given a circuit with some Q_0 , adding external lossless reactive elements to it in any series, series-parallel, or parallel fashion results in a new circuit with a Q greater than or equal to the original Q_0 .

Appendix E

EQUIVALENT CURRENT AND VOLTAGE GENERATORS

Consider a voltage generator of characteristic impedance Z_0 feeding an impedance Z , which may be any series, parallel, or series-parallel circuit.

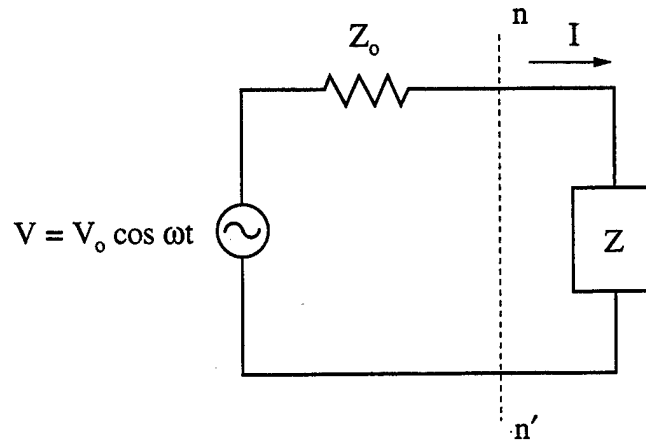

FIGURE E-1. Voltage Generator.

It is desired to replace the voltage generator with a current generator of characteristic admittance Y_0 , Z is unchanged, driving the same impedance, Z , so that the current through (and thus the voltage drop across

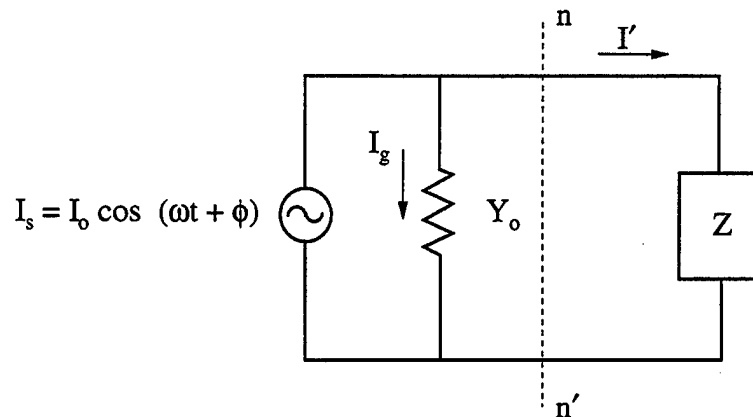

FIGURE E-2. Current Generator.

The two circuits are indistinguishable to the right of plane mm' if

$$I' = I \quad . \quad (E-1)$$

Now let

$$I = R \frac{V_0 e^{j\omega t}}{Z_0 + Z} \quad . \quad (E-2)$$

Let both Z and Z_0 be complex, thus allowing for a complex characteristic impedance although most texts treat Z_0 as real. Thus,

$$I = \text{Re} \frac{V_0 e^{j\omega t} e^{-j\theta}}{\sqrt{(R + R_0)^2 + (X + X_0)^2}} \quad (E-3)$$

where

$$\theta = \tan^{-1} \frac{X + X_0}{R + R_0} \quad (E-4)$$

or

$$I = \frac{V_0 \cos(\omega t - \theta)}{\sqrt{(R + R_0)^2 + (X + X_0)^2}} \quad . \quad (E-5)$$

For the current generator case

$$I_g + I' = I_s \quad . \quad (E-6)$$

From the circuit in Figure E-2, it is obvious that the voltage across Y_0 and Z must be the same, i.e.,

$$I_{gc} Z_0' = I_0' Z \quad . \quad (E-7)$$

Thus $I_c' \left(\frac{Z}{Z_0'} + 1 \right) = I_{sc}$ where the subscript c means complex notation. Thus

$$I_0' = \frac{I_{sc} Z_0'}{Z + Z_0'} \quad , \quad (E-8)$$

therefore $I' = \text{Re} \frac{Z_0' I_0' e^{j\omega t} e^{j\phi}}{Z + Z_0'}$

or

$$I' = \text{Re} \frac{I_0 |Z_0'| e^{j \tan^{-1} X_0' / R_0'} e^{-j\theta'} e^{j\phi}}{\sqrt{(R + R_0')^2 + (X + X_0')^2}} \quad (E-9)$$

where

$$\theta' = \tan^{-1} \frac{X + X_0'}{R + R_0'} \quad . \quad (E-10)$$

Finally,

$$I' = \frac{I_0 |Z_0'| \cos(\omega t + \phi - \theta' + \tan^{-1}(X_0' / R_0'))}{\sqrt{(R + R_0')^2 + (X + X_0')^2}} \quad (E-11)$$

Equating Equations E-11 and E-5, it can be seen that $I' = I$ if

$$Z_0 = Z_0' = \frac{1}{Y_0} \quad , \quad (E-12)$$

$$\Gamma_0 |Z_0'| = I_0 |Z_0| = V_0 \quad , \quad (E-13)$$

and

$$\phi = -\tan^{-1} X_0' / R_0' = -\tan^{-1} X_0 / R_0 \quad (\text{E-14})$$

thus Figures E-3 and E-1 are indistinguishable as far as Z is concerned.

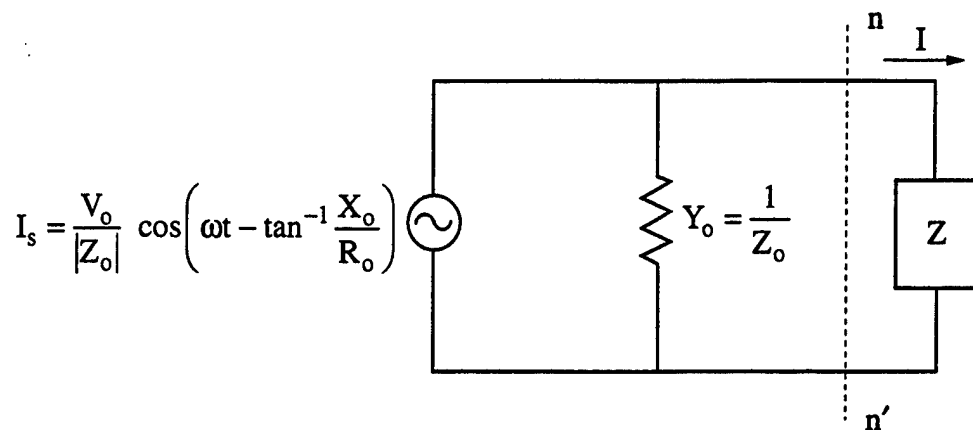

FIGURE E-3. The Correct Current Generator to Deliver the Identical Current to the Load as the Voltage Generator $V_o \cos \omega t$.

Note that a complex characteristic impedance requires a phase shift between the equivalent voltage and current generators.

INITIAL DISTRIBUTION

- 1 Chief of Naval Research, Arlington
 - W. Stachnik
- 3 Naval Air Warfare Center, Aircraft Division, Patuxent River
 - M. Fenton (1)
 - J. Stamm (1)
 - J. Asvestas (1)
- 1 Naval War College, Newport (1E22, President)
- 1 Headquarters, 497 IG/INTW, Falls Church (OUWG Chairman)
- 2 Defense Technical Information Center, Fort Belvoir
- 1 Center for Naval Analyses, Alexandria, VA (Technical Library)
- 6 Naval Air Warfare Center, Weapons Division, Point Mugu
 - Code 452100E, Hurley (1)
 - Code 454310E, Ryken (1)
 - Code 454510E, Adamski (1)
 - Code 534100E, Kujiraoka (1)
 - Code 539400E
 - Williams (1)
 - Schiefer (1)
- 2 Naval Research Laboratory
 - E. Mokole (1)
 - S. Sammadar (1)
- 1 Mitre Corporation, R. Fante
- 1 University of Kentucky
 - D. Grimes (1)
 - Craig Grimes (1)
- 1 University of Wisconsin, J. McClean

ON-SITE DISTRIBUTION

- 4 Code 4BL000D (3 plus Archives copy)
- 1 Code 4T4100D, Decker
- 3 Code 4T4110D
 - Bowling (1)
 - Chesnut (1)
 - DeSandre (1)
- 6 Code 4T4120D
 - Gillis (1)
 - Marrs (1)
 - Overfelt (4)
- 2 Code 4T4400D
 - Elson (1)
 - Tran (1)
- 1 Code 411000D, Keeter
- 1 Code 452100D
- 4 Code 45520D
 - Katzenstein (1)
 - Otto (1)
 - Roush (1)
 - Wang (1)
- 1 Code 471430D, Hilliard
- 1 Code 472C00D, Hewer
- 1 Code 472E00D, Burdick
- 1 Code 472G50D, Barbieri
- 1 Code 472200D, Hoppus
- 3 Code 472210D
 - Chew (1)
 - Kerns (1)
 - Skatvold (1)
- 3 Code 472220D
 - Afendyqiw (1)
 - Ghaleb (1)
 - Kidner (1)
- 3 Code 472230D
 - Bling (1)
 - Miller (1)
 - Paolino (1)
- 1 Code 472240D, Neel