

TM-70-6-FBR

FBR 4989

**AIR FORCE FLIGHT DYNAMICS LABORATORY
DIRECTOR OF LABORATORIES
AIR FORCE SYSTEMS COMMAND
WRIGHT PATTERSON AIR FORCE BASE OHIO**



The Installation and Operation of the
Scratch Strain Gage on a C-5A Aircraft

Theodore L. Haglage

**RETURN TO: AEROSPACE STRUCTURES
INFORMATION AND ANALYSIS CENTER
AFFDL/FBR
WPAFB, OHIO 45433**

Technical Memorandum 70-6-FBR

November 1970

19990817 051

**Reproduced From
Best Available Copy**

This document has been
approved for public release
and sale, its distribution
is unlimited

TM-70-6-FBR

The Installation and Operation of the
Scratch Strain Gage on a C-5A Aircraft

Theodore L. Haglage

Technical Memorandum 70-6-FBR

November 1970

FOREWORD

This report was prepared by Mr. Theodore L. Haglage of the Solid Mechanics Branch, Structures Division, Air Force Flight Dynamics Laboratory. The work was conducted in-house under Project 1467, "Structural Analysis Methods," Task 146704, "Structural Fatigue Analysis Methods."

This report covers work conducted from March 1970 through September 1970. The manuscript was released by the author in November 1970.

This technical memorandum has been reviewed and is approved.



FRANCIS J. JANIK JR
Chief, Solid Mechanics Branch
Structures Division

CONTENTS

SECTION I	Introduction	1
SECTION II	Gage Location and Installation	2
SECTION III	Data Retrieval	5
SECTION IV	Data Reduction	6
SECTION V	Results	7
SECTION VI	Conclusions	14
APPENDIX		15
REFERENCES		17

S E C T I O N I

INTRODUCTION

Flight test evaluation of the Prewitt Scratch Strain Gage (see Appendix for description) has previously been conducted on a T37-B jet trainer aircraft (Reference 1). The results and findings of this program indicate that the gage is an effective damage monitoring device capable of measuring and recording strain cycles of a character and magnitude found in a fighter aircraft structure.

In cooperation with the C-5 SPO, scratch gages were installed on a C-5A Galaxy temporarily based at Wright-Patterson Air Force Base, in an effort to demonstrate the operation of the scratch strain gage on a transport aircraft. A secondary objective of the program was to collect in-flight strain data in the vicinity of the connection of the inner wing to the center wing, W.S. 120.

S E C T I O N I I

GAGE LOCATION AND INSTALLATION

Initially, the inner wing front beam at W.S. 130 was investigated as a potential area for gage installation. Two location alternatives existed: the first being on the upper surface of the front beam upper cap, and the second on the lower surface of the front beam cap. Installation of the scratch gage on the upper surface (W.S. 130) would have necessitated using a protective cover, since the gage would be in the air stream and exposed to the environment. Instrumentation of the lower beam cap would require the removal of a wing-fuselage faring panel for installation and also for servicing of the gage, such as disc replacement, throughout the program. Upon encountering these problems, the center wing beams were investigated and finally chosen as the structural members to be instrumented since the structure is continuous along the beam caps between W.S. 120 and W.S. 0. The beam caps in this area (W.S. 0 to approximately W.S. 80) are completely enclosed within the fuselage and therefore no environmental protection was necessary. The upper and lower front beam caps and the upper rear beam cap are easily accessible for gage installation and servicing; however, the lower rear beam cap is not and therefore not instrumented.

Gage lengths were selected based on predicted strain levels and intended minimum strain range recording sensitivities of the respective gages. These minimum threshold sensitivities, as reported in

Reference 2, for the 12-inch and 6-inch gages are 150 $\mu\epsilon$ and 300 $\mu\epsilon$ respectively. Since the C-5A is a large transport aircraft and responsive to gust loading, it is necessary to record all strain cycles induced by gusts and small maneuvers in addition to the ground-air-ground cycles. At the installation area decided upon, the 12-inch gage is required in order to record all the damaging strain cycles. Six-inch gages, which would only record the larger strain cycles, such as the ground-air-ground cycles, were also used in order to further evaluate their capabilities such as sensitivity and disc capacity. The data could also be used for correlation studies. Four gages, two 6-inch and two 12-inch (Model H), were installed on the aircraft in the following locations, (Figure 1):

- a. six-inch gage - lower front beam cap, left side, W.S. 20
- b. twelve-inch gage - upper front beam cap, left side, W.S. 20
- c. six-inch gage - upper rear beam cap, left side, W.S. 20
- d. twelve-inch gage - upper rear beam cap, right side, W.S. 20

The gages were installed in approximately three hours using an epoxy adhesive with a curing time of 24 hours. Gage gaps (Reference 2) were set at values ranging from 0.020" to 0.052".

Although two of the gages were temperature compensated for aluminum, the effect of strain variance due to a temperature gradient was negligible since all gages were installed inside the fuselage and not exposed to severe environmental conditions.

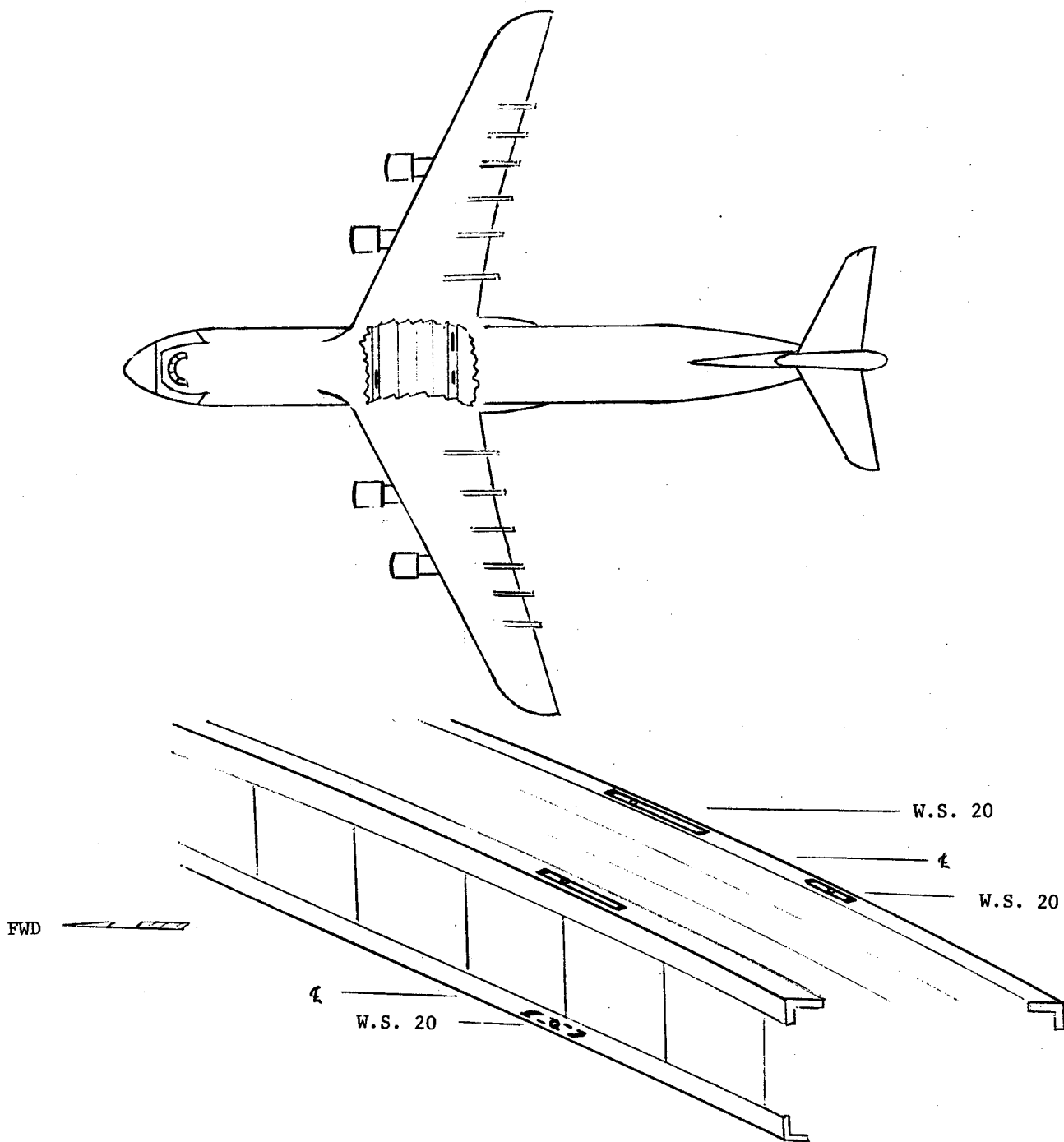

Figure 1: SCRATCH GAGE LOCATIONS ON
C-5A CENTER WING BEAM CAPS

S E C T I O N I I I

DATA RETRIEVAL

With the restriction that the recording disc be allowed to make only a single revolution, and therefore have no overlapped scratch traces, it is estimated that the disc capacity of the 12-inch front beam gage would be approximately 22-25 flight hours and that of the 12-inch rear beam gage would be 12-15 hours, the difference being the more highly strained rear beam. The disc capacity variance in a single gage, however, is due to flight profile differences, (altitude, weight) and also the length of individual flights. For the purposes of this study, the discs were replaced after each flight during the initial phase of the program. This procedure also served as an adequate check-out for any gage malfunctions of which there were none. After removal of a recorded disc, it was immediately tagged and labeled with pertinent information, such as gage number, location, and date. A new disc upon insertion was rotated manually a small amount for the purpose of recording a reference strain level. This arc can also be made at the end of a flight for detecting strain change due to decreased fuel load.

S E C T I O N I V

DATA REDUCTION

The recorded scratch traces were reduced to the form of sequential occurrences of peak (max and min) values of strain using three methods. Initially, a calibrated microscope was used to measure the actual scratch length. This is a tedious and time consuming operation (30 to 60 minutes per disc) but very accurate. Secondly, a method involving the use of an optical comparator was utilized which is much faster than the microscope (approximately 10 minutes per disc) since the measurements are automatically recorded on punch cards. The third method is a privately developed system, the nucleus of which is an electronic optical scan engine which automatically reads the disc in radial and circumferential directions by sensing a reflected light spot. The digitized data is then stored on magnetic tape to be used for damage calculations and life prediction analyses. This system, currently still in the developmental stage, is capable of scanning a recorded disc and storing the data in 30 seconds, but 30 minutes are required by the computer to analyze the data using the associated digital program and print out the results. It is presently thought possible to reduce this process to two to three minutes of elapsed time by the addition of larger and more sophisticated scanning and computer equipment.

The latter two reduction methods, comparator and scan engine, were performed by private companies.

S E C T I O N V

RESULTS

The segment of the flight program during which the scratch gages were installed and operating endured for a total of four months; however, the twelve-inch gages were operational for only the first half of this time. During the latter two months, the aircraft was not operating out of Wright-Patterson, but rather from the Naval Air Station, El Centro, California, and therefore, was not available for disc replacement. Both six-inch gages did remain operational throughout the entire four months.

Portions of five discs for each 12-inch gage contain strain data, (ten discs total), with two discs having recordings on both sides. This collection of data represents 11 flights totaling 41.1 hours of flight time. The minimum strain range threshold sensitivity demonstrated by these gages was equal to $100 \mu\epsilon$. This is not to say that strain range cycles less than this were not recorded, but rather that scratch trace separation due to the disc rotation consistently occurred for values $\geq 100 \mu\epsilon$. This is sufficiently small for accurate damage calculations. The maximum compressive and tensile strains recorded by the 12-inch gages throughout the flight program were $-1500 \mu\epsilon$ and $+756 \mu\epsilon$ respectively. The gages as installed were capable of recording strain amplitude values as large as $-3300 \mu\epsilon$ and $+1600 \mu\epsilon$. Figure 2 is a photomicrograph of a small segment of a scratch

trace recorded by the forward 12-inch gage. From the left, the trace starts with the reference arc A; taxi strain cycles, B ($<100 \mu\epsilon$); tensile strain cycle during take-off, C; gust cycles in the compressive region, D.

As stated previously, the minimum strain range sensitivity of the six-inch gage was $300 \mu\epsilon$, and consequently, strain cycles induced by gust loads and small maneuvers were not recorded. Disc rotation occurred only for larger strain ranges resulting from ground-air-ground cycles including touch-and-go maneuvers as well as full stop landings and thereby greatly increased the disc replacement interval. A minimum disc capacity estimate for this installation is approximately 250 ground-air-ground cycles, and is therefore, basically independent of individual flight lengths.

A scratch trace of a series of strain cycles made by the six-inch gage mounted on the rear beam upper cap (Figure 3) is the recording of two full stop ground-air-ground cycles followed by nine touch-and-go maneuvers and a final full stop.

The reduced strain data of a single flight recorded by the twelve-inch aft gage is listed in Table I. This tabulation also serves as a comparison of three methods of data reduction. Table II presents a set of reduced data typical of the six-inch forward gage. The difference in the reduction precision is apparent in the $\Delta\epsilon$ columns; however, as shown in the accompanying plots, (Figure 4 and 5), the basic trends are the same.

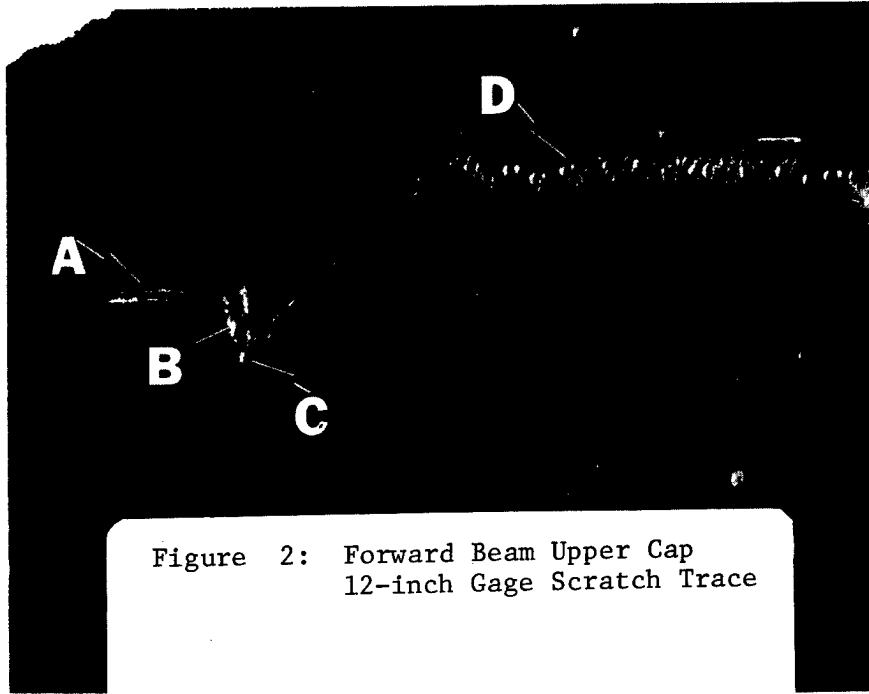

Figure 2: Forward Beam Upper Cap
12-inch Gage Scratch Trace



Figure 3: Rear Beam Upper Cap
6-inch Gage Scratch Trace

Table I: Strain Data Reduction Comparison
(12-inch Scratch Gage)

Microscope			Scan Engine			Comparator		
Max	Min	$\Delta\epsilon$	Max	Min	$\Delta\epsilon$	Max	Min	$\Delta\epsilon$
$\mu\epsilon$	$\mu\epsilon$	$\mu\epsilon$	$\mu\epsilon$	$\mu\epsilon$	$\mu\epsilon$	$\mu\epsilon$	$\mu\epsilon$	$\mu\epsilon$
0	100	100				104	104	0
-16	475	491	50	541	491	0	500	500
316	416	100	442	508	66	313	417	104
325	441	116	400	550	150	271	458	187
191	316	125	267	317	50	-41	375	416
8	150	142	58	208	150	0	208	208
-766	-558	108	-733	-566	167	-770	-562	208
-725	-575	150	-758	-508	250	-728	-582	146
-708	-575	133	-650	-500	150	-666	-478	188

Table II: Strain Data Reduction Comparison
(6-inch Scratch Gage)

Microscope			Scan Engine			Comparator		
Max	Min	$\Delta\epsilon$	Max	Min	$\Delta\epsilon$	Max	Min	$\Delta\epsilon$
$\mu\epsilon$	$\mu\epsilon$	$\mu\epsilon$	$\mu\epsilon$	$\mu\epsilon$	$\mu\epsilon$	$\mu\epsilon$	$\mu\epsilon$	$\mu\epsilon$
0	117	117	-333	900	1233	0	425	425
-200	1017	1217	383	533	150	75	1250	1175
-418	1033	1451	-467	783	1250	83	1208	1125
-83	817	900	483	617	134	167	1000	833
450	817	367	-267	717	984	667	1000	333
433	817	384	317	700	383	667	958	291
450	783	333	433	733	300	667	1000	333
417	817	400	517	750	233	692	1017	325
433	783	350	450	733	283	692	1042	350
417	833	416	400	783	383	683	1000	317
400	833	433	583	767	184	758	1017	259
450	833	383	400	783	383	667	1000	333
383	800	417	450	733	283	333	0	-333
117	233	116	333	750	417			
-50			-333	200	533			

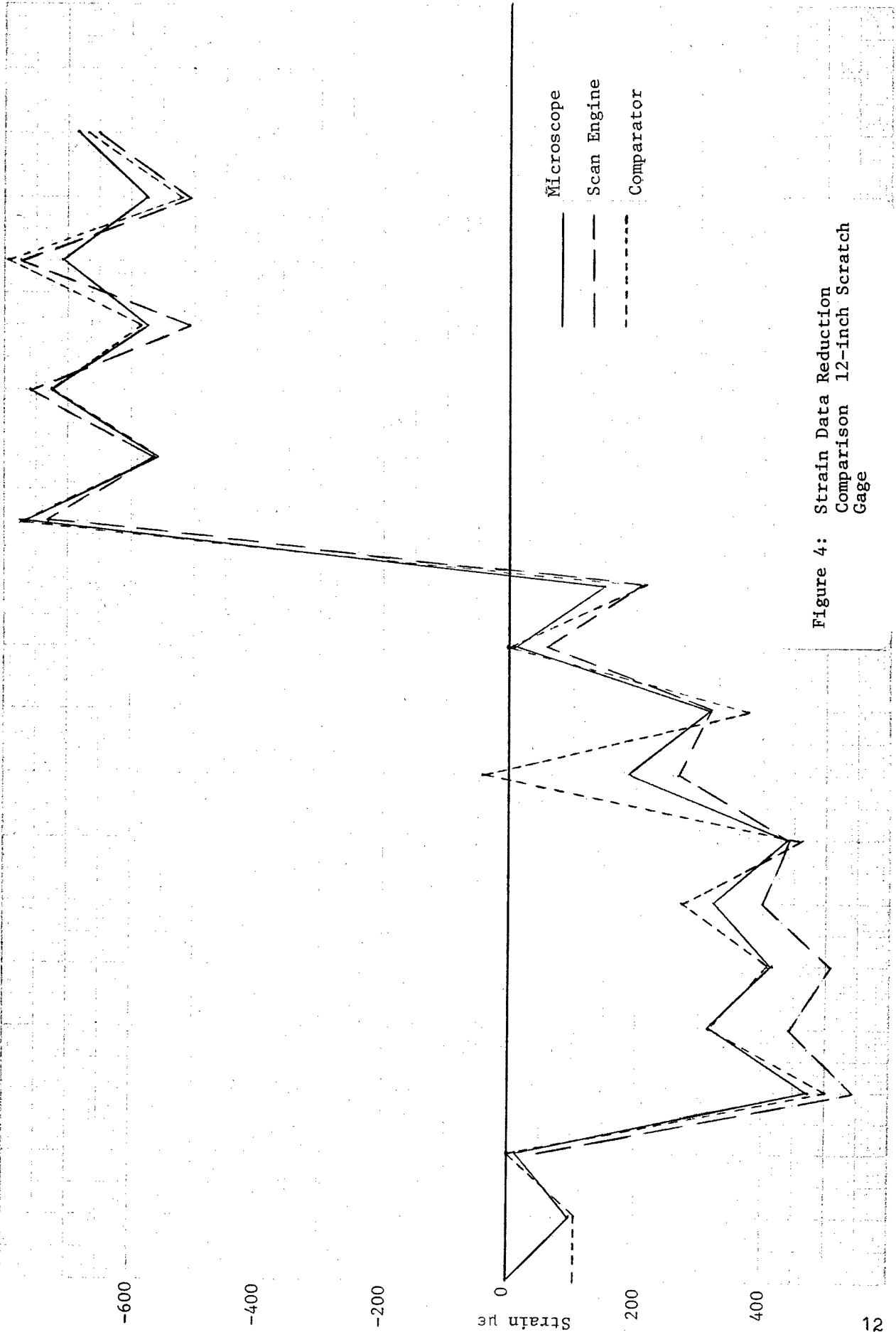

Figure 4: Strain Data Reduction Comparison 12-inch Scratch Gage

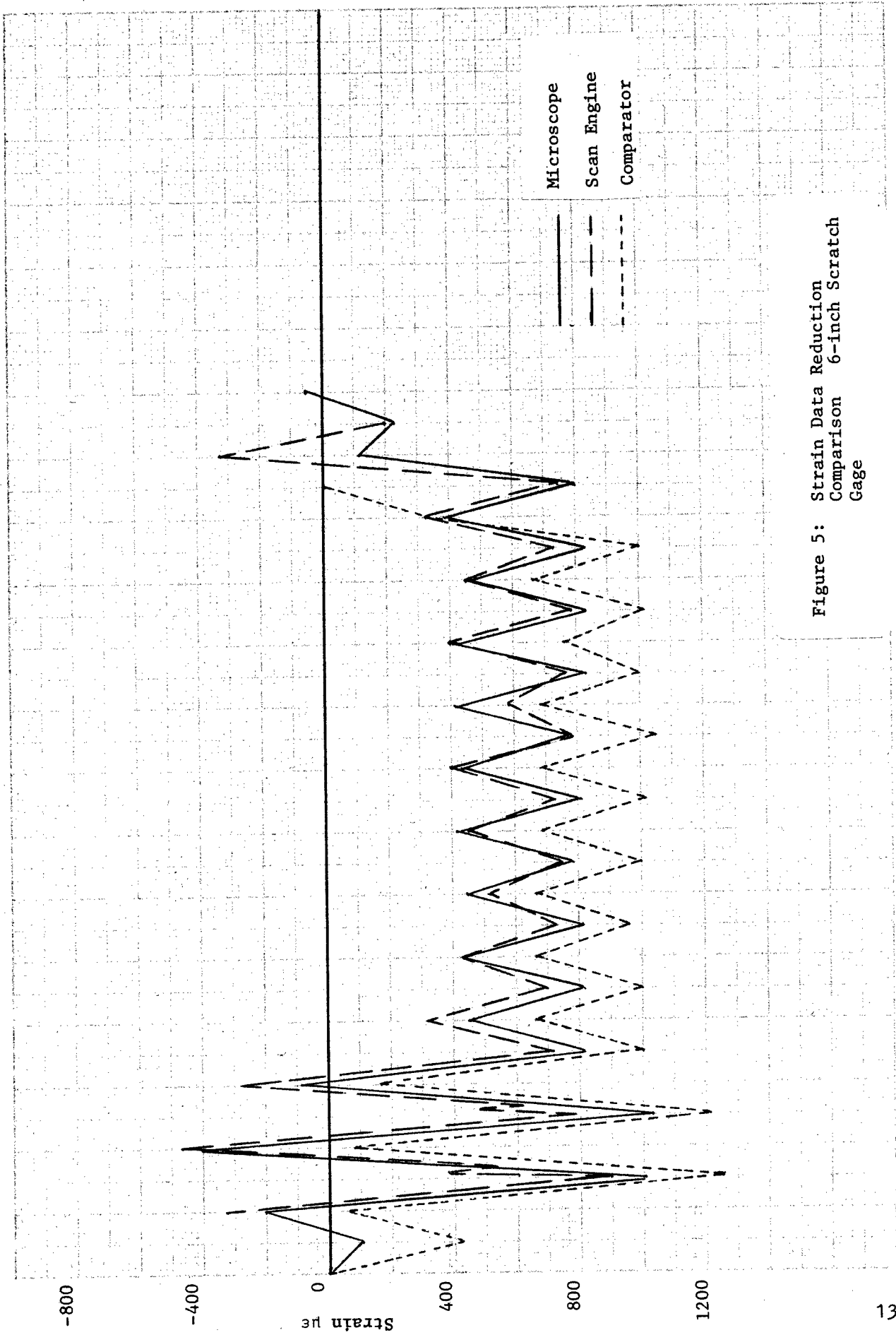

Figure 5: Strain Data Reduction Comparison 6-inch Scratch Gage

S E C T I O N V I

CONCLUSIONS

On the C-5A, the gages, two 6-inch and two 12-inch, performed satisfactorily and recorded strains equal to or less than their respective sensitivities.

The automated data reduction procedures discussed herein have excellent potential for future applications. These systems are currently being refined to levels of greater precision and accuracy. In addition, the time required for the respective operations is being reduced considerably.

A P P E N D I X

GAGE DESCRIPTION

The Prewitt Scratch Strain Gage (Figure 6) is a self-contained mechanical extensometer capable of measuring and recording total deformation (and thus average strain) over the effective installed gage length of the member to which it is attached. The gage consists of two steel base plates (1) and (2), with (1) containing a recording stylus, and (2) the brass recording disc. Physical attachment of the gage assembly to the structure is achieved by either bonding, clamping, or screwing the ends of each base plate.

The outer periphery of the disc is grooved so as to accommodate two rollers (A and B, Figure 6) and encased steel wire brushes (C and D, Figure 6) used to hold the disc in place.

As the structure is strained, the two base plates move relative to each other, causing the stylus to scratch the disc and record the total movement. Automatic rotation of the disc occurs under cyclic straining allowing separation of each strain excursion. This counterclockwise rotation is accomplished during gage contraction by the tangential force of the longer brush, D on the circumference of the disc. The shorter brush, C, is used merely to prevent reverse rotation.

Three standard lengths, three-, six-, and 12- inch are available. However, longer gages and gages temperature-compensated for steel or aluminum can be obtained.

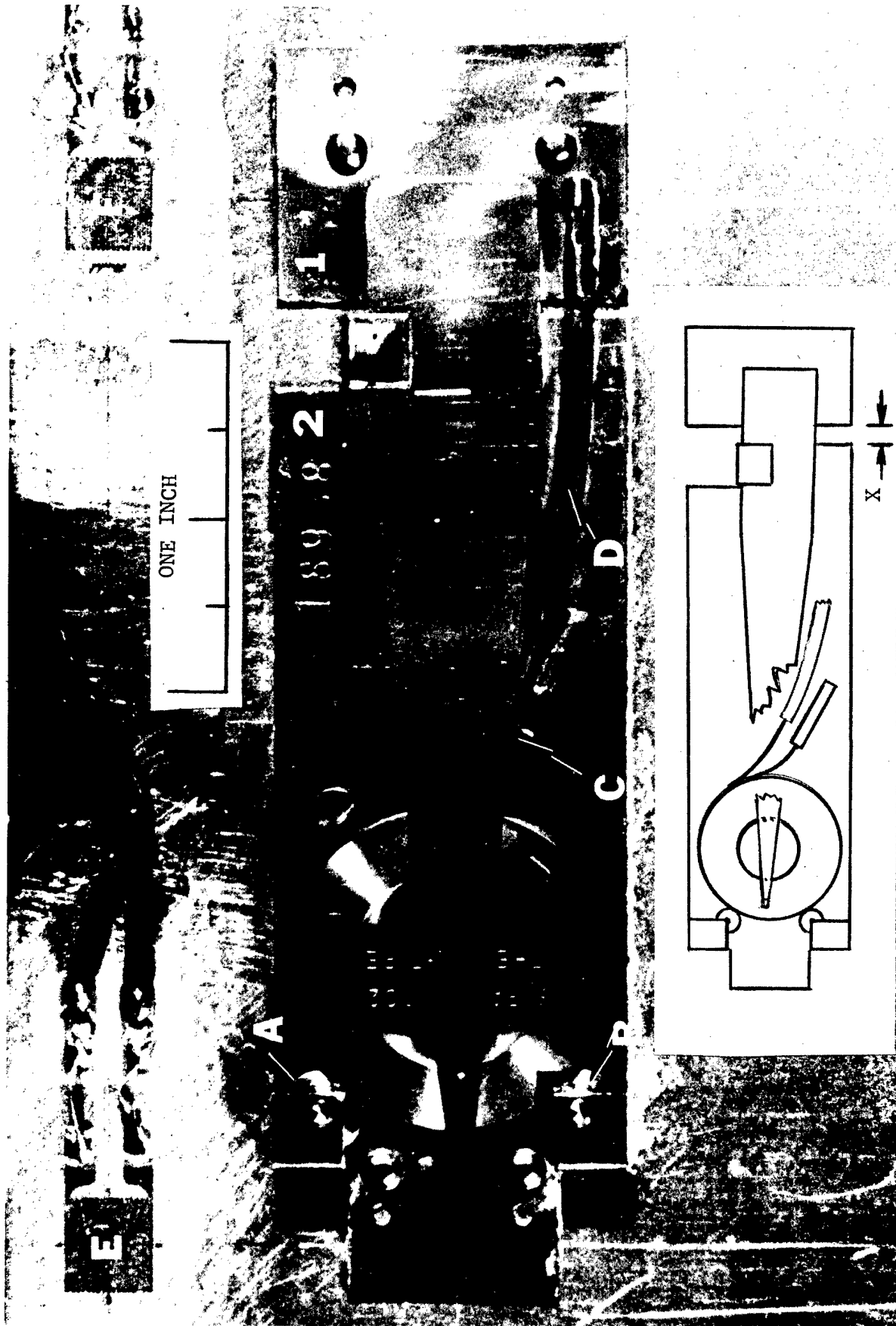

Figure 6: Three Inch Prewitt Scratch Strain Gage

REFERENCES

1. Haglage, T.L., "Flight Test Evaluation of a Scratch Strain Gage," AFFDL-TR-69-116, June 1970.
2. Haglage, T.L., Wood, H.A., "Scratch Strain Gage Evaluation," AFFDL-TR-69-25, July 1969.