

AFRL-PR-WP-TR-1998-2113

**ROBUST 300°C WIRE
INSULATION SYSTEM**



**WING C. WONG
ROBERT J. JONES**

**TRW SPACE & DEFENSE
ONE SPACE PARK
REDONDO BEACH CA 90278**

SEPTEMBER 1998

FINAL REPORT FOR PERIOD JANUARY 1994 – JUNE 1997

APPROVED FOR PUBLIC RELEASE; DISTRIBUTION UNLIMITED

**PROPULSION DIRECTORATE
AIR FORCE RESEARCH LABORATORY
AIR FORCE MATERIEL COMMAND
WRIGHT-PATTERSON AIR FORCE BASE, OH 45433-7251**

DTIC QUALITY INSPECTED 4

19990825 120

NOTICE

USING GOVERNMENT DRAWINGS, SPECIFICATIONS, OR OTHER DATA INCLUDED IN THIS DOCUMENT FOR ANY PURPOSE OTHER THAN GOVERNMENT PROCUREMENT DOES NOT IN ANY WAY OBLIGATE THE US GOVERNMENT. THE FACT THAT THE GOVERNMENT FORMULATED OR SUPPLIED THE DRAWINGS, SPECIFICATIONS, OR OTHER DATA DOES NOT LICENSE THE HOLDER OR ANY OTHER PERSON OR CORPORATION; OR CONVEY ANY RIGHTS OR PERMISSION TO MANUFACTURE, USE, OR SELL ANY PATENTED INVENTION THAT MAY RELATE TO THEM.

THIS REPORT IS RELEASABLE TO THE NATIONAL TECHNICAL INFORMATION SERVICE (NTIS). AT NTIS, IT WILL BE AVAILABLE TO THE GENERAL PUBLIC, INCLUDING FOREIGN NATIONS.

THIS TECHNICAL REPORT HAS BEEN REVIEWED AND IS APPROVED FOR PUBLICATION.



JOHN G. NAIRUS
Program Manager
Electrical Technology Branch
Power Division

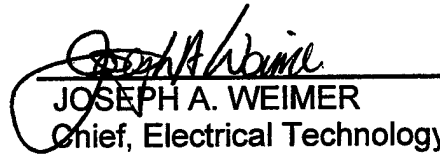

JOSEPH A. WEIMER
Chief, Electrical Technology Branch
Power Division

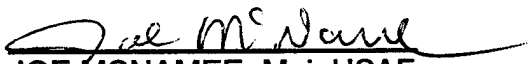

JOE MCNAMEE, Maj, USAF
Acting Chief
Power Division

IF YOUR ADDRESS HAS CHANGED, IF YOU WISH TO BE REMOVED FROM OUR MAILING LIST, OR IF THE ADDRESSEE IS NO LONGER EMPLOYED BY YOUR ORGANIZATION PLEASE NOTIFY AFRL/PRPE WRIGHT-PATTERSON AFB OH 45433-7251 TO HELP MAINTAIN A CURRENT MAILING LIST.

Do not return copies of this report unless contractual obligations or notice on a specific document requires its return

REPORT DOCUMENTATION PAGE

Form Approved
OMB No. 0704-0188

Public reporting burden for this collection of information is estimated to average 1 hour per response, including the time for reviewing instructions, searching existing data sources, gathering and maintaining the data needed, and completing and reviewing the collection of information. Send comments regarding this burden estimate or any other aspect of this collection of information, including suggestions for reducing this burden, to Washington Headquarters Services, Directorate for Information Operations and Reports, 1215 Jefferson Davis Highway, Suite 1204, Arlington, VA 22202-4302, and to the Office of Management and Budget, Paperwork Reduction Project (0704-0188), Washington, DC 20503.

1. AGENCY USE ONLY (Leave blank)		2. REPORT DATE September 1998	3. REPORT TYPE AND DATES COVERED FINAL January 1994 - June 1997	
4. TITLE AND SUBTITLE ROBUST 300°C WIRE INSULATION SYSTEM			5. FUNDING NUMBERS C: F33615-93-C-2367 PE: 62203F PR: 3145 TA: 29 WU: LD	
6. AUTHOR(S) WING C. WONG ROBERT J. JONES				
7. PERFORMING ORGANIZATION NAME(S) AND ADDRESS(ES) TRW SPACE & DEFENSE ONE SPACE PARK REDONDO BEACH CA 90278			8. PERFORMING ORGANIZATION REPORT NUMBER	
9. SPONSORING/MONITORING AGENCY NAME(S) AND ADDRESS(ES) Propulsion Directorate Air Force Research Laboratory Air Force Materiel Command Wright-Patterson Air Force Base, OH 45433-7251 POC: John Nairus, AFRL/PRPE, 937-255-6016			10. SPONSORING/MONITORING AGENCY REPORT NUMBER AFRL-PR-WP-TR-1998-2113	
11. SUPPLEMENTARY NOTES				
12a. DISTRIBUTION AVAILABILITY STATEMENT APPROVED FOR PUBLIC RELEASE; DISTRIBUTION UNLIMITED			12b. DISTRIBUTION CODE	
13. ABSTRACT (Maximum 200 words) The objective was to develop an advanced wire insulation system having improved electrical and thermal properties over the state-of-the-art Kapton® based systems for applications in future generation spacecraft or aircraft. The program focused on using PFPI and PFE-285 films with AFR700B and FM680-1 polyimides as adhesives to bond film layers. All are commercially available and reported to possess excellent electrical and thermal properties. A test matrix was conducted on these film/adhesive candidates and the PFPI/AFR700B was selected as the most promising insulation system. Substantial exploratory work was performed to define the process parameters for manufacturing the insulated conductor wire. The process steps involve (1) casting PFPI film from solution, (2) spray-coated with AFR700B with a solution diluted with methanol, (3) coated film was slit and spliced into continuous tape, (4) coated tapes were wrapped onto a 20 AWG nickel-plated strand wire, and (5) final cure. Results from this development program indicate that substantially more effort is necessary to yield a truly superior polymeric dielectric insulation film material. Exploratory work is needed to modify molecular structure of PFPI by extending the mean molecular weight to improve its flexibility while retaining its high temperature dielectric properties and resistance to thermal oxidative environment.				
14. SUBJECT TERMS High Temperature Polymeric dielectric film, High Temperature Wire Insulation System, PFPI, AFR700B, thermal - electrical properties			15. NUMBER OF PAGES 78	
			16. PRICE CODE	
17. SECURITY CLASSIFICATION OF REPORT UNCLASSIFIED	18. SECURITY CLASSIFICATION OF THIS PAGE UNCLASSIFIED	19. SECURITY CLASSIFICATION OF ABSTRACT UNCLASSIFIED	20. LIMITATION OF ABSTRACT SAR	

TABLE OF CONTENTS

	<u>Page</u>
PREFACE	V
SUMMARY	1
1.0 PROGRAM APPROACH	4
1.1 TASK 1 - FILM/ADHESIVE CANDIDATE SCREENING	4
1.2 TASK 2 - DATABASE PROPERTY DETERMINATION	6
1.3 TASK 3 - INITIAL WIRE INSULATION AND TESTING	6
2.0 TASK 1 EXPERIMENTATION	9
2.1 PREPARATION OR PROCUREMENT OF FILM MATERIALS	9
2.2 THERMAL ANALYSIS	11
2.3 ELECTRICAL PROPERTY MEASUREMENTS	14
2.4 MECHANICAL PROPERTY MEASUREMENTS	16
3.0 TASK 2 EXPERIMENTATION	19
3.1 ISOTHERMAL AGING IN AIR AT 300°C	19
3.2 FLUID IMMERSION TESTING	21
3.3 HUMIDITY AGING AT 90°C/95% RELATIVE HUMIDITY	22
3.4 ELECTRICAL TESTING OF EXPOSED SYSTEM SAMPLES	23
4.0 TASK 3 EXPERIMENTATION	24
4.1 CONTINUOUS CASTING OF PFPI FILM MATERIAL	24
4.2 FILM DRYING WITH HOT PLATE OVEN	36
4.3 SPRAY COATING OF PFPI FILM WITH AFR700B	40
4.4 WIRE WRAPPING EXPERIMENTS	42
4.5 FILM SLITTING	47
4.6 WIRE WRAPPING	48
4.7 THERMAL PROCESSING OF INSULATED WIRE	51
4.8 CAUSES OF THE DRYING PROBLEM	53
5.0 CONCLUSIONS	54
6.0 RECOMMENDATIONS FOR FURTHER WORK	56
7.0 REFERENCES	57
APPENDIX	58

LIST OF TABLES

	<u>Page</u>
TABLE 1. INITIAL FILM/ADHESIVE POLYMER CANDIDATES	4
TABLE 2. APPROVED TASK 1 TEST MATRIX.....	5
TABLE 3. APPROVED TASK 2 FILM/ADHESIVE SYSTEM CANDIDATES	6
TABLE 4. APPROVED TASK 2 TEST MATRIX.....	7
TABLE 6. MECHANICAL PROPERTIES OF WIRE INSULATORS	17
TABLE 7. EFFECT OF 300°C AIR AGING	20
TABLE 8. EFFECT OF DS-108 CLEANING SOLVENT EXPOSURE	22
TABLE 9. EFFECT OF 90°C/95% RH AGING	23
TABLE 10. PFPI FILM DRYING TEST.....	25
TABLE 11. PFPI FILM PROCESS TEMPERATURES AND AIR FLOWS	31
TABLE 12. OPTIMIZED HEATING SCHEDULE	39
TABLE 13. EFFECT OF HEATING CONDITIONS ON PFPI/AFR700B FILM	41
TABLE 14. RESULTS OF FIRST WIRE WRAPPING EXPERIMENT.....	44
TABLE 15. RESULTS OF SECOND WIRE WRAPPING EXPERIMENT.....	45
TABLE 16. TOWER HEATER RESULTS	51
TABLE 17. TOPCOAT TOWER HEATER RESULTS.....	52

LIST OF FIGURES

	<u>Page</u>
FIGURE 1. RDA SPECTRUM ON KAPTON [®]	11
FIGURE 2. RDA SPECTRUM OF PFPI (4BDAF/PMDA FORMULATION).....	12
FIGURE 3. RDA SPECTRUM OF FPE-265.....	12
FIGURE 4. RDA SPECTRUM OF FM680-1 REINFORCED WITH 106 CLOTH	13
FIGURE 5. RDA SPECTRUM OF AFR700B REINFORCED WITH 106 CLOTH	13
FIGURE 6. RDA SPECTRUM OF MODIFIED AFR700B REINFORCED WITH 106 CLOTH	14
FIGURE 7. EFFECT OF 300°C AGING ON PFPI SYSTEMS, FPE SYSTEMS AND KAPTON [®]	21
FIGURE 8. FTIR SPECTRA OF LABORATORY PREPARED PFPI FILMS	26
FIGURE 9. TRAILBLAZER STUDY PLAN	29
FIGURE 10. CASTING PFPI FILM AT REXAM.....	30
FIGURE 11. TYPICAL TGA PROFILES OF REXAM-CAST PFPI FILMS	32
FIGURE 12. FTIR SPECTRA OF REXAM-CAST PFPI FILMS	33
FIGURE 13. SCHEMATIC OF CONTINUOUS FILM PROCESSING OVEN	37
FIGURE 14. PHOTOGRAPHS OF THE CONTINUOUS FILM PROCESSING OVEN	38
FIGURE 15. FTIR SPECTRUM OF REXAM-CAST FILM CURED IN CONTINUOUS OVEN	39
FIGURE 16. CONFIGURATION OF WIRE WRAPPING TEST SAMPLE	43
FIGURE 17. PHOTOMICROGRAPHS OF HEAT-TREATED INSULATED CONDUCTORS	46
FIGURE 18. CORE DIMENSION FOR SPOOLING OF THE SLIT TAPE	47
FIGURE 19. SAMPLES OF PFPI/AFR700B TAPES WITH AND WITHOUT MYLAR [®] WEB.....	48
FIGURE 20. INSULATOR CONSTRUCTIONS FOR WRAPPING CONDUCTOR.....	49
FIGURE 21. 20 AWG CONDUCTOR WRAPPED WITH PFPI/AFR700B INSULATION	50

PREFACE

TRW is pleased to submit the Final Report on Contract F33615-93-C-2367 to the USAF Wright Laboratory/Aero Propulsion and Power Directorate. The technical period of performance described herein spanned from January 1994 to June 1997, and was conducted in the Space & Technology Division of TRW. Dr. Robert J. Jones served as TRW's Program Manager until his retirement in June 1994, upon which he continued to serve as a technical consultant. Dr. Wing Wong served as TRW's Program Manager until the completion of the contract. Mr. Ward Wright, Hsiao-Hu Peng, and Art Rico of the Materials Technology and Engineering Department performed the laboratory work in polymeric film casting, adhesive spray-coating and wire wrapping, and provided technical support throughout the program.

A number of vendors, as listed below, provided polymeric materials supply, material conversion, wire wrapping and property testing services during the program:

- CommScope Wire wrapping
- Cytec FM680-1 polyimide film
- DuPont Kapton[®] polyimide film
- HyComp AFR700B polyimide polymer preparation
- Lawrence Technology Film electrical property testing
- Poly-Materials PFPI polyimide polymer preparation
- Rexam Continuous film preparation
- 3M FPE-265 aromatic polyester film
- Web Converting Film slitting and tape splicing

The authors also want to specially thank Mr. John Nairus and his associates at WL/POOC-1 for their assistance in the electrical testing of the selected film/adhesive samples.

SUMMARY

Contract F33615-93-C-2367, entitled "Robust 300°C Wire Insulation System", was sponsored and directed by the USAF Aero Propulsion and Power Directorate as a continuation of Contract F33615-88-C-2909, entitled "High Temperature Polymer Dielectric Film Insulation". The program scope, objective, approach and technical accomplishments are summarized below.

Insertion of a fully electric power system in future USAF aircraft is hampered by a lack of high-temperature wire insulation material. The state-of-the-art insulator, Kapton[®], shows sharp increase in dielectric loss with increasing temperature, poor long-term oxidation resistance at over 280°C and high incidence of arc tracking failure. Its applicability in missions with temperature requirements over 300°C is highly suspect.

The previous program had successfully identified two advanced aromatic/heterocyclic film-forming polymers having improved electrical and thermal properties over Kapton[®] for wire insulation applications in future generation spacecraft or aircraft. They were Upilex[®]S and PFPI (Partially Fluorinated Polyimide). Upilex[®]S is directly available as a film from a foreign source; PFPI is available domestically but only in varnish. Two key technical problems remained unsolved at the completion in the previous program:

- The production demonstration of PFPI film casting and tape wrapping by automated manufacture processes and
- The identification and demonstration of a $\geq 300^{\circ}\text{C}$ performing adhesive or film tape sealant.

This Contract focused on using PFPI film with AFR700B polyimide as an adhesive to bond film layers, using FPE-265 (an aromatic polyester film from 3M) and FM680-1 (a fluorinated polyimide adhesive based on Avimid N chemistry) as back-ups. All candidates are commercially available and are reported to possess excellent thermal and electrical properties.

The overall objectives of this program were two-fold:

- Selection of a most promising insulation candidate and
- Demonstration of high performance insulating capability of this candidate as a film wrapped material on copper wire.

The program was conducted according to the following sequences:

TASK	KEY TESTS	OUTPUT OF TASK
1	Screen six film/adhesive candidates for: <ul style="list-style-type: none">• Dielectric constant and dissipation factor• Breakdown voltage• Dry arc tracking• Tensile properties• Lap shear strength• RDA Dynamic Work Loss	<ul style="list-style-type: none">• Down select to four promising candidates (PFPI/AFR700B, PFPI/FM680-1, FPE-265/AFR700B, and FPE-265/FM680-1); document test plan for conducting remainder of program
2	Perform detailed test on four system candidates: <ul style="list-style-type: none">• Accelerated aging in air at 300°C• Accelerated aging in high humidity air at 90°C• Compatibility with aircraft degreasing fluid• Testing dielectric strength of exposed samples	<ul style="list-style-type: none">• Down select PFPI film with AFR700B adhesive as the most promising candidate
3	Perform process development work: <ul style="list-style-type: none">• Casting of PFPI film by a solvent method• Thermal processing to fully cured film• Coating of film with AFR700B adhesive• Slitting and splicing of coated film into tapes• Wrapping of AWG 20 conductor wire• Thermal processing of wrapped wire• Initial testing of the insulated wire (8 kV impulse, dynamic cut-through and flex life)	<ul style="list-style-type: none">• Wire test data/samples and recommendations for future work

In Task 1, only PFPI was successfully cast into film from varnish. Its tensile and electrical properties were tested along with FPE 265 and Kapton[®] as control. The dielectric constant and the dissipation loss of PFPI film are significantly lower. Its ac dielectric strength at room temperature is similar to that FM680-1, but slightly below that of Kapton[®]. The lap shear test demonstrated good bond strength for all film/adhesive systems. Modified AFR700B was eliminated because of its low glass transition temperature (260°C).

The four candidates were tested in Task 2 for their thermal oxidation stability, hygro-thermal stability and compatibility to aircraft degreasing solvent by subjecting them to 300°C aging in air, 95% RH/90°C, and immersion in DS-108 at ambient temperature. The FPE-265 film systems degrade readily in 300°C oxidative environment and the FM680-1 bonded systems are less compatible to AFR700B bonded systems in DS-108 immersion. Therefore, PFPI film bonded with AFR700B adhesive was selected as the single most promising candidate for Task 3.

To demonstrate the superior performance of the PFPI/AFR700B insulated conductor wire over the state-of-the-art construction entails substantial exploratory work to define the manufacturing process parameters. The process steps involve:

1. Casting of PFPI film from solution at Rexam.
2. Spray-coating the PFPI film with AFR700B from a solution diluted with methanol. The initial plan of solution-casting AFR700B film on dried PFPI film was abandoned due to difficulties encountered during exhaustive drying of the as-cast PFPI film.
3. The coated film was slit and spliced at Web Converting into rolls of ¼" wide continuous tape for wire wrapping.
4. The coated tapes were wrapped onto a 20 AWG nickel-plated copper strand wire at CommScope, and the inner layer and outer layer of the insulation were laid down in a single pass. Each layer consisted of a double wrap with a 52% overwrap. Cracking and blistering of the PFPI film occurred during the final drying of the wrapped wire. This was likely to be caused by incomplete removal of the last traces of moisture and solvent prior to the cure at elevated temperatures or the poor mechanical properties (or low molecular weight) of as-cast PFPI film.

Results from this success-oriented program indicate that substantially more effort is necessary to yield truly superior polymeric dielectric insulation film material. More work is needed to increase PFPI's mean molecular weight, thereby improving its flexibility while retaining most of its desirable electrical and thermal properties.

1.0 PROGRAM APPROACH

This program was conducted by sequentially performing the following tasks:

1.1 TASK 1 - FILM/ADHESIVE CANDIDATE SCREENING

Task 1 evaluates six film/adhesive combinations (two promising film and three adhesive candidates), selected based on their reported properties that should contribute to a superior 300°C wire insulation system. A summary description of these polymer candidates is shown in Table 1.

Table 1. INITIAL FILM/ADHESIVE POLYMER CANDIDATES

CANDIDATE	POLYMER TYPE	REPORTED MAX. SERVICE TEMP.	RATIONALE FOR SELECTION
Dielectric Film			
PFPI FORMULATION 4-BDAF/PMDA	FLUORINATED POLYIMIDE	>300°C	VERY PROMISING CANDIDATE SHOWN TO POSSESS SUPERIOR 300°C ELECTRICAL PROPERTIES ON CONTRACT F33615-88C-2909
FPE-265	AROMATIC POLYESTER	~300°C	SHOWN TO POSSESS SUPERIOR CAPACITOR FILM ELECTRICAL PROPERTIES BY WL/POOC-1
Adhesive			
AFR700B	FLUORINATED POLYIMIDE	UP TO 371°C	SHOWN TO POSSESS EXCELLENT POTENTIAL FOR HIGH MECHANICAL PROPERTY RETENTION UP TO 371°C
FM680-1	FLUORINATED POLYIMIDE	UP TO 371°C	SHOWN TO POSSESS HIGH ADHESIVE PROPERTY RETENTION AT >300°C
MODIFIED AFR700B ^{a)}	FLUORINATED POLYIMIDE	UP TO 371°C (PROJECTED)	STANDARD AFR700B POLYMER MAY NEED TO BE MODIFIED TO ACHIEVE OPTIMUM BALANCE OF MECHANICAL AND ELECTRICAL PROPERTIES

a) Specific formulation to be selected upon completion of initial unmodified AFR700B testing.

The total film/adhesive candidates were screened per Table 2, with Kapton[®] as a control. Tests included electrical properties (dielectric constant/dissipation factor, breakdown voltage and arc tracking) and thermal-mechanical property determinations (tensile and lap shear mechanical properties and Rheometrics Dynamic Analysis).

Table 2. APPROVED TASK 1 TEST MATRIX

CANDIDATE TYPE OR CLASS	SPECIFIC CANDIDATE	DIELECTRIC CONSTANT/DISSIPATION FACTOR AT RT, 280°C AND 300°C AT 400 Hz & 1000 Hz	BREAKDOWN VOLTAGE, ac & dc AT RT, 280°C AND 300°C	DRY ARC TRACKING AT RT	TENSILE PROPERTIES AT RT, 280°C AND 300°C	LAP SHEAR STRENGTH AT RT, 280°C AND 300°C	RDA DYNAMIC WORK LOSS, -100°C TO +500°C
POLYMER	1. KAPTON® FILM (CONTROL)	YES	YES	YES	NO	N/A	YES
	2. PPI FILM	YES	YES	YES	YES	N/A	YES
	3. FPE-265 FILM	YES	YES	YES	YES	N/A	YES
	4. AFR700B	YES	YES	YES	NO	N/A	YES
	5. FM-680-1	YES	YES	YES	NO	N/A	YES
	6. MOD. AFR700B	YES	YES	YES	NO	N/A	YES
FILM/ADHESIVE SYSTEM	2 BONDED WITH 4	YES	YES	YES	N/A	YES	N/A
	2 BONDED WITH 5	YES	YES	YES	N/A	YES	N/A
	2 BONDED WITH 6	YES	YES	YES	N/A	YES	N/A
	3 BONDED WITH 4	YES	YES	YES	N/A	YES	N/A
	3 BONDED WITH 5	YES	YES	YES	N/A	YES	N/A
	3 BONDED WITH 6	YES	YES	YES	N/A	YES	N/A

Four candidates, i.e., PFPI/AFR700B, FPE-265/AFR700B, PFPI/FM680-1 and FPE-265/FM680-1, were downselected for Task 2 based on Task 1 results (Table 3).

Table 3. APPROVED TASK 2 FILM/ADHESIVE SYSTEM CANDIDATES

POLYMER/ADHESIVE SYSTEM CANDIDATE	SELECTION RATIONALE
PFPI/AFR700B	DEMONSTRATED EXCELLENT POTENTIAL FOR SERVICE AT 300°C WITH GLASS TRANSITION TEMPERATURE (BY DMA, G' KNEE) IN EXCESS OF 320°C
FPE-265/AFR700B	
PFPI/FM680-1 ^{a)}	DEMONSTRATED ACCEPTABLE BONDING CAPABILITY WITH TENSILE LAP SHEAR TESTING AT RT AND 300°C
FPE-265/FM680-1 ^{a)}	ELIMINATE MODIFIED AFR700B AS ADHESIVE DUE TO LOW GLASS TRANSITION TEMPERATURE (260°C), LACK OF LAP SHEAR STRENGTH AT 300°C AND MARGINAL PROCESSABILITY

^{a)} Extracted resin from FM680-1 film adhesive

1.2 TASK 2 - DATABASE PROPERTY DETERMINATION

A test matrix (Table 4) was developed, with USAF approval, to fully assess their potential as a robust wire insulation material for conductors in Task 2. Based upon the experimental test results, PFPI/AFR700B was selected as the most promising film/adhesive candidate for the process development work in Task 3.

1.3 TASK 3 - INITIAL WIRE INSULATION AND TESTING

Task 3 includes the following activities:

- Casting of continuous length of PFPI film material by a solvent method
- Thermal processing to fully imidize and post-cure of the cast PFPI film
- Coating one side of the PFPI film with AFR700B adhesive
- Slitting/splicing of AFR700B coated PFPI film into continuous wire insulation tapes
- Wrapping of 20 AWG strand copper wire with the PFPI/AFR700B insulation tape
- Thermal processing of wrapped wire to fully cure the AFR700B adhesive

- Initial testing of the insulated wire to evaluate its potential

Table 4. APPROVED TASK 2 TEST MATRIX

Test A. Isothermal Aging (Exposed Specimens to Flowing Air at 300°C for 1000 Hour)

MEASUREMENT	AGING TIME (Hour)								SPECIMEN REQUIREMENT (TESTED IN TRIPLICATE)
	0	24	48	144	264	528	768	1000	
WEIGHT CHANGE	X	X	X	X	X	X	X	X	12
VISUAL INSPECTION	X	X	X	X	X	X	X	X	12
TOUGHNESS ON "FLEXING" OR "BENDING"	X	X	X	X	X	X	X	X	12
DRY ARC TRACKING AT RT	X							X	24
BREAKDOWN VOLTAGE, ac & dc, AT RT & 300°C	X							X	96
DIELECTRIC PROPERTY AT RT, 280°C & 300°C, AT 400 Hz & 1 KHz	X							X	8

Test B. Aircraft Fluid Immersion Test (Immersed in DS-108 Degreasing Solvent at Room Temperature for 168 Hour)

MEASUREMENT	AGING TIME (Hour)		SPECIMEN REQUIREMENT (TESTED IN TRIPLICATE)
	0	168	
WEIGHT CHANGE	X	X	12
VISUAL INSPECTION	X	X	12
TOUGHNESS	X	X	12
DRY ARC TRACKING AT RT		X	12

Test C. Hygrothermal Aging (90°C and 95% RH, for 1000 Hour)

MEASUREMENT	AGING TIME (Hour)								SPECIMEN REQUIREMENT (TESTED IN TRIPLICATE)
	0	24	48	144	264	528	768	1000	
WEIGHT CHANGE	X	X	X	X	X	X	X	X	12
VISUAL INSPECTION	X	X	X	X	X	X	X	X	12
TOUGHNESS	X	X	X	X	X	X	X	X	12
DRY ARC TRACKING								X	12
BREAKDOWN VOLTAGE								X	48
DIELECTRIC PROPERTY								X	4

2.0 TASK 1 EXPERIMENTATION

The five polymeric dielectric candidates, PFPI (4-BDAF/PMDA formulation), FPE-265, AFR700B, modified AFR700B and FM680-1, as well as the Kapton[®] control, were studied in Task 1 as follows:

- Preparation or procurement of film materials
- Thermal analysis
- Electrical property measurements
- Mechanical property measurements

Each activity is separately described below.

2.1 PREPARATION OR PROCUREMENT OF FILM MATERIALS

Samples of the Kapton[®] control and FPE-265 were obtained as films in a nominal 1 mil thickness from DuPont and 3M, respectively. PFPI (4-BDAF/PMDA formulation), FM680-1, AFR700B and modified AFR700B were not available as cured films and were cast from the commercially available precursor materials for property testing.

The PFPI varnish was obtained from Poly-Materials at 25 weight % solids loading in N-methyl-2-pyrrolidinone (NMP). This varnish was filtered through micro-porous Teflon[®] filters (down to 2.5-micron pore size) and cast into 4 mils thick coating on a flat glass plate. The plate was placed in a vacuum oven, and the temperature was raised to 200°C in increments of 50°C per hour, held at 200°C for 2 hours, and allowed to cool to ambient temperature. The PFPI film was peeled away from the glass plate and its reverse side taped to the glass. The assembly was placed into a convection oven at 200°C for 1 hour, followed by raising the temperature in 50°C increments per hour until the film reached 371°C, and held at this temperature for 1 hour. The oven was then cooled to 200°C and the glass plate removed and cooled to room temperature. This technique yielded 1 mil thick films after separating from the plate. In addition, 2 mil and 5 mils PFPI films were also prepared (after substantial trial-and-error) for dry arc track test per ASTM 495.

The FM680-1 film adhesive (5 mil nominal thickness) obtained from Cytec contains reactive components, polyimide precursors and phenylene diamine, and inert fillers, amorphous silica and ceramic scrim cloth (Reference 1). There was no established procedure from the vendor to cast the material into a 1 mil film. Exploratory work was conducted to extract the resin with a solvent mixture of NMP and methyl ethyl ketone (MEK). Several attempts were made to cast film with no success.

The AFR700B prepolymer obtained from HyComp contains a molar ratio 1:9:8 of 5-nadic-ester (NE): *p*-phenylene diamine (*p*PDA): dimethyl 4, 4'-(hexafluoroisopropylene)-bis(phthalate) (6FDE) in 25% solvent (Reference 2). It has low aliphatic content of 2.3% and a formulated molecular weight of 4400. To improve its flexibility, a modified AFR700B formulation was made by replacing the *p*PDA with the diamine 2,2-bis-[4-(4-aminophenoxy)phenyl] hexafluoropropane (4-BDAF) as follows:

1. A mixture of 88.8g (0.20 mole) of 4,4'-(hexafluoroisopropylidene)-bis(phthalic anhydride) (6FDA) and 72 ml of anhydrous methanol was heated at reflux and stirred until the 6FDA was completely dissolved. The heating and mixing continued for 2 more hours to form a solution of the diester derivative of 6FDA (6FDE).
2. A mixture of 4.686g (0.0286 mole) of 5-norbornene-2,3-dicarboxylic nadic anhydride (nadac anhydride or NA) and 12 ml of anhydrous methanol was heated at reflux and stirred until the NA was dissolved. The heating was continued for an additional hour to form a solution of the monoester derivative of NA (NE).
3. The methanolic solution of 6FDE was slowly added at room temperature to a suspension of 100.4g (0.20 mole) of 4-BDAF diamine in 72ml of anhydrous methanol to form a polymer solution. The NE solution was immediately added once the 6FDE/4-BDAF mixture went into solution, again at room temperature, to give the desired modified AFR700 prepolymer at a molar ratio of NE:4-BDAF:6FDE of 1:7:7 and a theoretical molecular weight of about 6530 g/mole.

Laboratory work was also conducted to cast AFR700B and modified AFR700B into 1 mil thick films for electrical property testing. These attempts were not successful because of extremely low viscosity of these prepolymer materials.

2.2 THERMAL ANALYSIS

Samples of 1 mil thick Kapton[®], PFPI and FPE-265 films were subjected to Rheometrics Dynamic Analysis (RDA) to measure storage modulus and detect the glass transition temperature (T_g), at which the storage modulus breaks significantly. The film samples were scanned between -100°C to +500°C in flowing air, using a Rheometrics RDA-700 instrument at 60Hz under a load of approximately 100g. Measurements of FM680-1, modified AFR700B and AFR700B were performed with cured composites reinforced with 106 glass scrim cloth, due to our inability to cast workable films. The RDA results are presented in Figures 1 through 6.

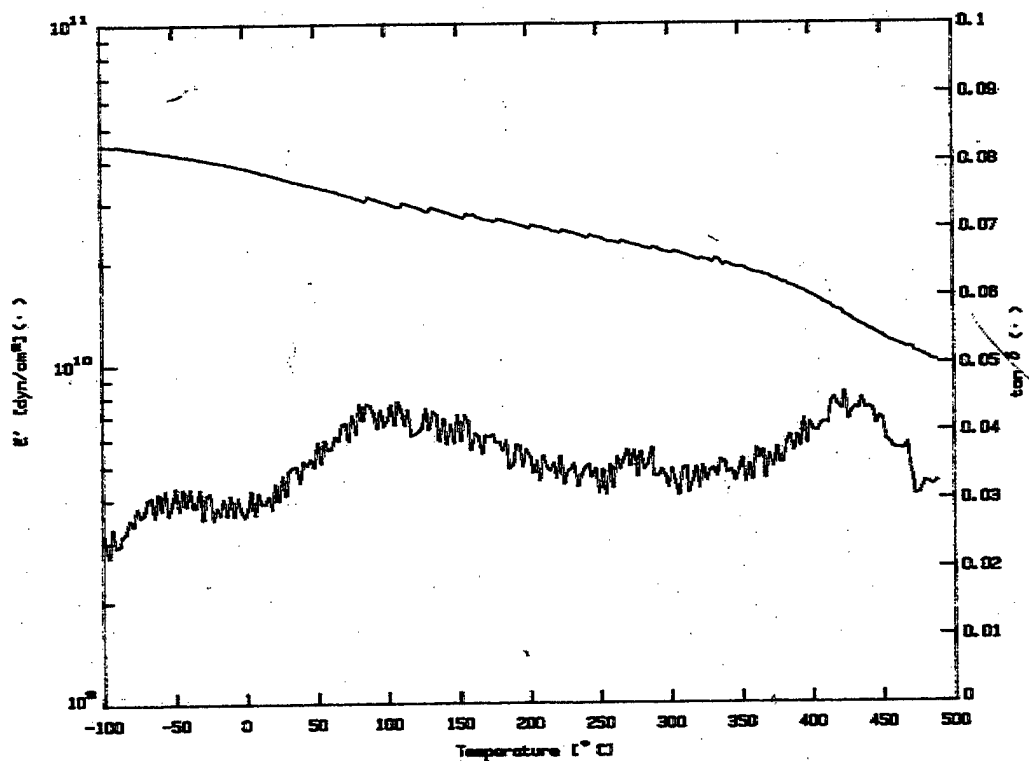

Figure 1. RDA Spectrum on Kapton[®]

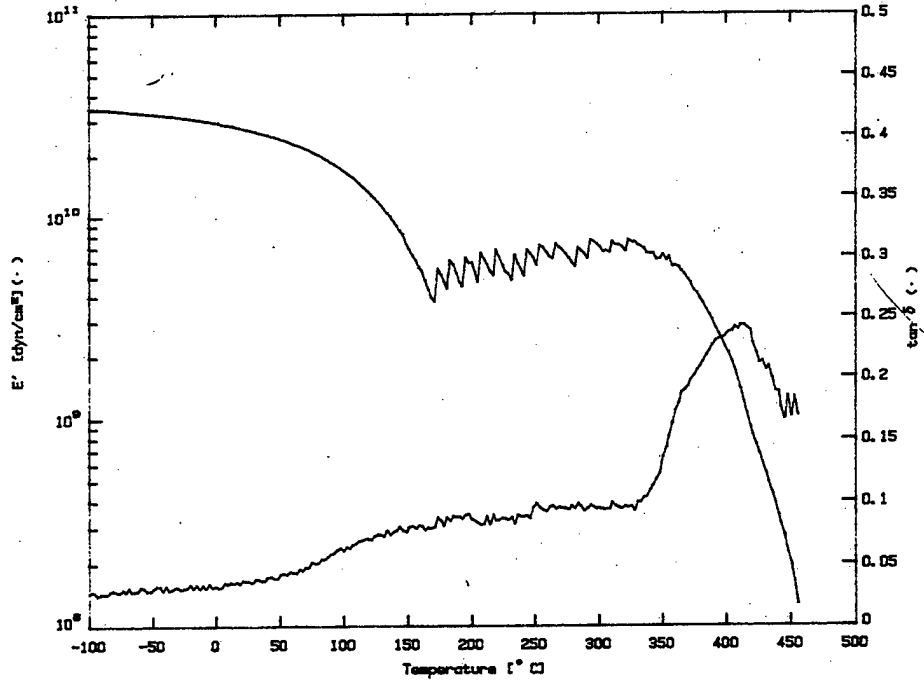

Figure 2. RDA Spectrum of PFPI (4BDAF/PMDA Formulation)

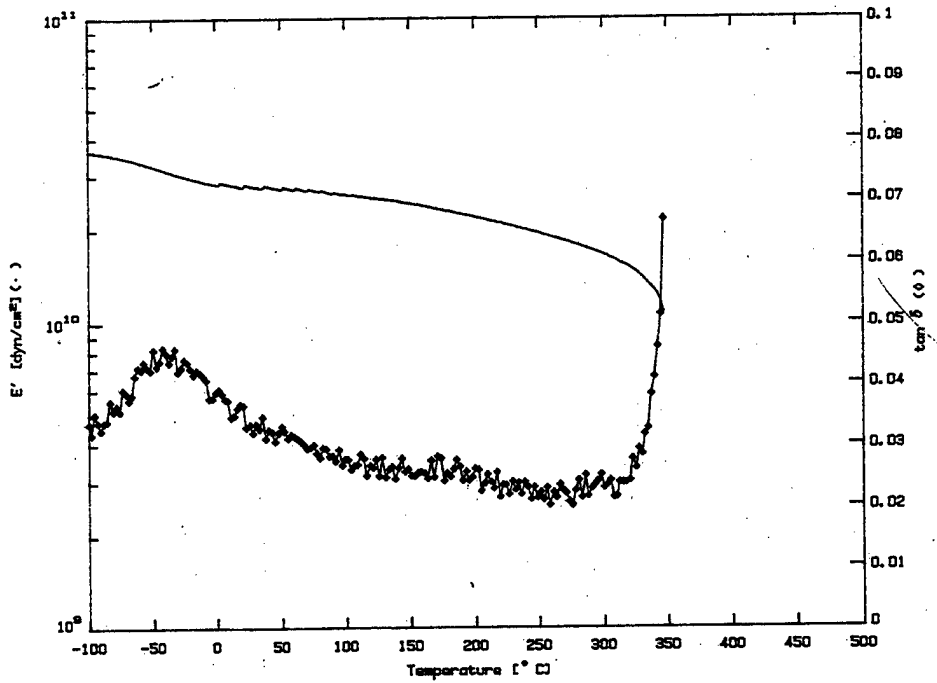

Figure 3. RDA Spectrum of FPE-265

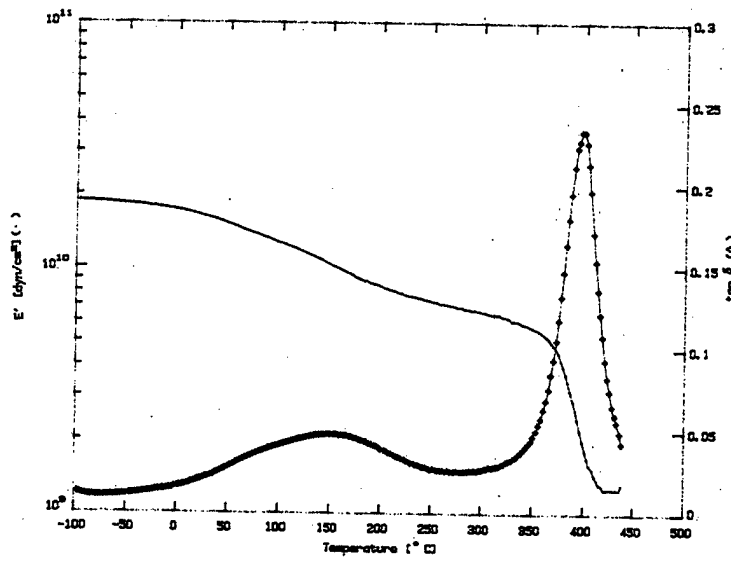

Figure 4. RDA Spectrum of FM680-1 Reinforced with 106 Cloth

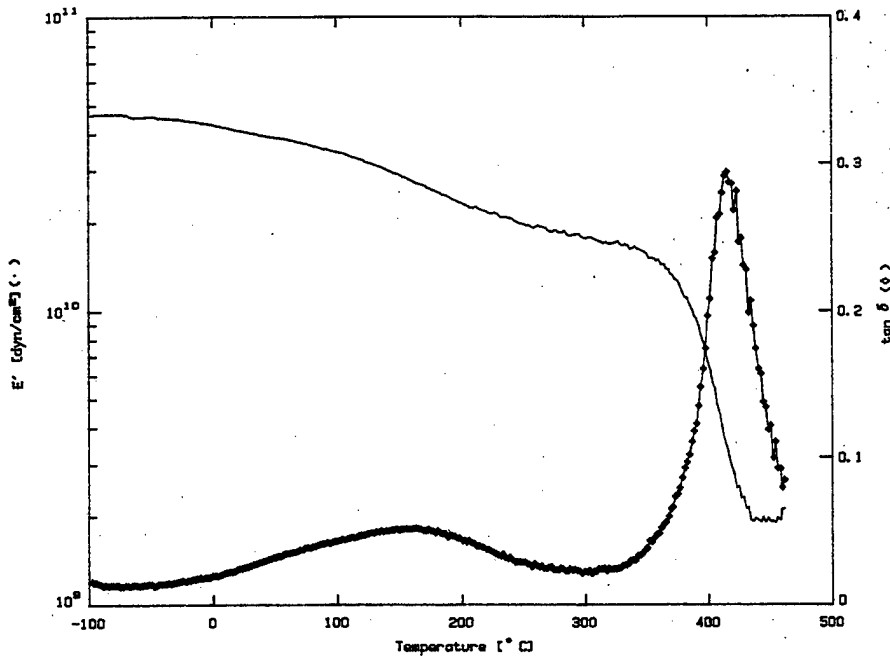

Figure 5. RDA Spectrum of AFR700B Reinforced with 106 Cloth

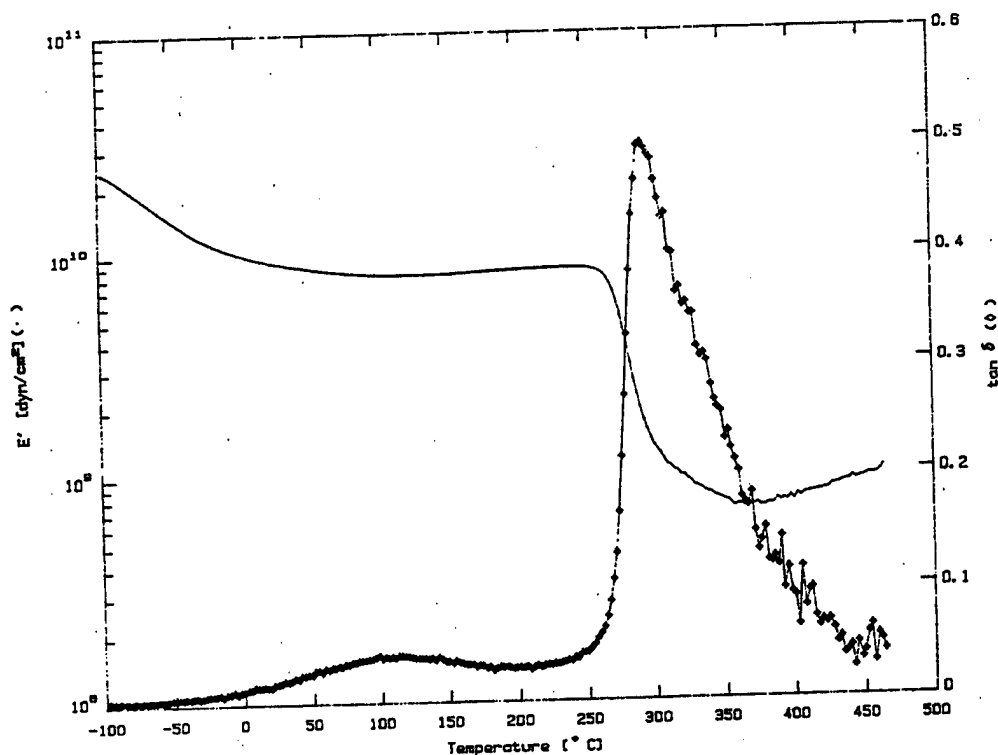

Figure 6. RDA Spectrum of Modified AFR700B Reinforced with 106 Cloth

The RDA spectra for PFPI and Kapton[®] were almost identical to those obtained in prior work on Contract F33615-88-C-2909 showing a T_g of about 350°C for PFPI and no definitive T_g for Kapton[®]. The T_gs for FPE-265, FM 680-1, AFR700B, modified AFR700B were determined by RDA to be about 320°C, 370°C, 380°C, and 260°C, respectively. The modification on the AFR700B resin to improve its flexibility apparently reduces its T_g much more than desired.

2.3 ELECTRICAL PROPERTY MEASUREMENTS

The dielectric constant κ' , dissipation factor κ''/κ' , and the breakdown voltage of the Kapton[®], FPE-264 and PFPI film at room temperature and elevated temperature were tested at Lawrence Technology in accordance with ASTM D150, and ASTM D149, respectively (Table 5). Comparing to Kapton[®] and FPE-265, the κ' and κ''/κ' of PFPI film are significantly lower for the various combinations of temperature (room and 300°C) and frequency (400Hz and 1kHz). The ac breakdown voltage of PFPI at room temperature is

comparable to that of FPE-265, but slightly below that of Kapton®. The higher ac breakdown voltage for Kapton® is not unexpected since DuPont had engineered the film quality and properties for optimal performance. The dc results showed that PFPI has higher room-temperature breakdown voltage than Kapton®.

Table 5. ELECTRICAL PROPERTY OF WIRE INSULATORS^{a)}

Dielectric Properties

PROPERTY	TEMP (°C)	FREQUENCY (kHz)	KAPTON®	PFPI	FPE-265
κ' REAL PART	RT	0.4	3.46	2.08	3.07
		1	2.45	2.08	3.10
	300	0.4	2.89	1.91	2.82
		1	2.88	1.91	2.82
κ''/κ' DISSIPATION FACTOR	RT	0.4	0.0045	0.0028	0.0057
		1	0.0051	0.0011	0.0115
	300	0.4	0.0051	0.0010	0.0017
		1	0.0044	0.0008	0.0017

Breakdown Voltage in kV per mil

TEMP (°C)	ac/dc	KAPTON®	PFPI	FPE-265
RT ^{b)}	ac (60Hz)	6.6, 7.3	6.8, 6.3	6.3, 6.3
	dc	11.2, 9.9	13.3, 10.4	13.1, 11.4
300	ac	2.6	3.2	2.1
	dc	4.2	5.7	5.1

Dry Arc Track In Second

TEMP (°C)	KAPTON®	FPE- 265	PFPI
RT	183	159	135
300	-	-	-

a) included data from previous program (Reference 3).

b) test repeated.

The high-temperature breakdown voltage tests and the room-temperature dry arc tracking tests were not completed because the vendor experienced frequent equipment problems. Selected film samples were eventually forwarded to Wright Laboratory WL/POOC-1 for testing, and the results will be published at later date. The FM680-1, AFR700B and modified AFR700B could not be cast in films and were not tested.

2.4 MECHANICAL PROPERTY MEASUREMENTS

Tensile testing of Kapton®, FPE-265 and PFPI at RT and 300°C was conducted per ASTM D882 on a Model 1122 Instron tester using 5" x 0.5" x 1 mil samples (Table 6). Due to the poor quality of cast films, the tensile properties of FM680-1, AFR700B and modified AFR700B were not measured. As expected, the absolute strengths of the candidate FPE-265 and PFPI films were lower than the Kapton® control due to the development nature, but exceeded a 20% minimum goal in terms of percent of RT strength retained at 300°C. The tensile strength of PFPI is in reasonable agreement with the tensile properties reported in the previous study (Reference 3), i.e., 9.4 ksi for strength and 6.2% for elongation-at-break. It was pointed out in the study that the PFPI "stiffens" or decreases the elongation-at-break when subjected to increasingly longer postcure exposure at 371°C (7.9 ksi and 3.6% after 8 hours).

Table 6. MECHANICAL PROPERTIES OF WIRE INSULATORS

TENSILE PROPERTIES	TEMP (°C)	KAPTON®	PFPI	FPE-265	AFR 700B
STRENGTH ^{a)} (ksi)	RT	28.6	11.5	11.5	-
	250	17.3	7.0	4.2	-
	300	11.6	2.9	2.8	-
ELONGATION ^{b)} (%)	RT	75	6.2	-	<10

^{a)} Data reported are an average of quadruplicate determinations

^{b)} Reported literature values

SUBSTRATE	ADHESIVE	LAP SHEAR STRENGTH ^{a)} (ksi)		% STRENGTH RETENTION AT 300°C
		RT	300°C	
PFPI	AFR700B	1.55	1.00	65
	MOD. AFR700B	2.34	-	-
	FM680-1	1.52	0.58	38
FPE-265	AFR700B	0.92	0.20	22
	MOD. AFR700B	-	-	-
	FM680-1	1.78	0.33	19

^{a)} Data reported are an average of a minimum of duplicate determinations.

The AFR700B, modified AFR700B and solvent-extracted FM680-1 were cast on PFPI and FPE-265 films to prepare the lap shear samples. The film materials being employed were about 0.375" wide x 1 mil thick coated with a 0.5 mil thick adhesive layer. The samples were bonded by laying-up two films with adhesive layers face-to-face with an 1" overlap and 1 mil bond thickness. During specimen preparation, excessive foaming and occasional air channel formation took place on the adhesive layer upon heating due to

the boil-off of solvents. Attempts to pre-remove the solvent by drying failed due to poor resin flow or uneven adhesive spread during cure.

The lap shear test results are summarized in Table 6. The 300°C lap shear test was not performed for modified AFR700B adhesive because of its marginal temperature capability. The RT and 300°C strengths of the tested candidate systems all meet the minimum lap shear tensile property goal of 100 psi. In fact, all breaks occurred in the unbonded areas of the film specimen, indicating the shear strengths exceed the tensile strength of the film.

3.0 TASK 2 EXPERIMENTATION

Based on Task 1 results, PFPI/AFR700B, FPE-265/AFR700B, PFPI/FM680-1, FPE-265/FM680-1 were chosen for study in Task 2 to assess:

- The aging characteristics at maximum temperature, by exposing samples to flowing air at 300°C for 1000 hours.
- The effect of Dynamolds DS-108, a degreaser commonly used for military aircraft maintenance, on wire insulation, by immersing samples to this fluid at room temperature for 168 hours.
- The aging characteristic in humid air, by exposing samples in air at 95% relative humidity and 90°C for 1000 hours.

The exposed test specimens were characterized for the change in dielectric properties (dielectric constant and dissipation factor, breakdown voltage and dry arc tracking). In order to conduct some of these electrical tests, laminated film/adhesive samples of 2.5 mils thickness were prepared. The sample consisted of laminating adhesive (thickness of about 0.5 mil) between two films (each 1 mil thick). The sample preparation procedure was similar to that described earlier for preparing lap shear specimen by casting 0.25 mil thick adhesive on each film.

3.1 ISOTHERMAL AGING IN AIR AT 300°C

Isothermal aging of the four film/adhesive system candidates was conducted in air at 300°C for 1000 hours to test their high temperature oxidative stability. Duplicate samples (1.25" long x 1.25" inch wide x 2.5 mil thick) were placed in an air circulating oven (400 ft³/minute air flow) at 300°C, and weighed after 24, 48, 120, 264, 528, 768, and 1000 hours. The results (Table 7) are plotted in Figure 7, and isothermal aging data for Kapton[®] film from Reference 3 are included for comparison. Kapton[®] degraded readily at 300°C in this environment, and became brittle after about 500 hours.

Table 7. EFFECT OF 300°C AIR AGING

AGING DURATION (HOURS)	PERCENT WEIGHT LOSS BY CANDIDATE FILM/ADHESIVE SYSTEM ^{a)}				
	PFPI/ AFR700B	PFPI/ FM680-1	FPE-265/ AFR700B	FPE-265/ FM680-1	KAPTON® FILM
24	1.3	1.2	1.8	5.6	1.4
48	1.2	1.3	2.2	6.7	1.4
120	1.6	1.6	3.9	10.0	2.0
264	2.3	2.1	8.6 ^{b)}	18.2 ^{b)}	3.3
528	3.7	2.9	21.6	50.0	6.0
768	5.0	3.6	27.0	65.6	8.8
1000	6.2	4.6	28.5	70.7	13.0

a) Average of duplicate samples

b) Onset of severe sample darkening/curling

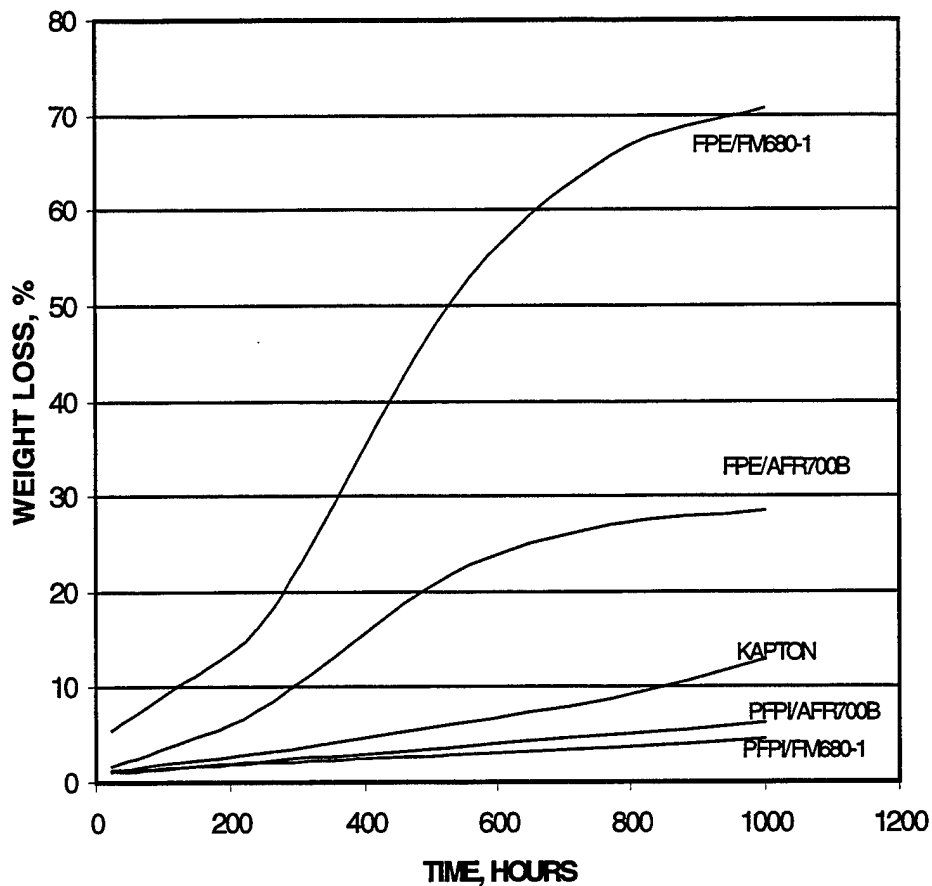

Figure 7. Effect of 300°C Aging on PFPI Systems, FPE Systems and Kapton®

The results showed that PFPI systems are significantly better than the Kapton® systems regardless of the choice of adhesive (AFR700B or FM680-1), but the FPE-265 systems are less resistant than Kapton®.

The test samples were periodically removed from the oven and visually examined. The FPE-265 system samples darkened, curled, and hardened after 11 days of aging. No major change was apparent with the PFPI samples.

3.2 FLUID IMMERSION TESTING

System samples of dimensions 1.0 inch long x 0.5 inch wide x 5 mil thick were immersed at ambient temperature for 1 week in DS108, an ozone non-depleting chemical being

used by Boeing for handwipe cleaning. The film samples were fitted with a clip at each end. One clip was attached to a circular metal ring at the top of resin kettle, which is filled with the cleaner to a level such that approximately one-half of each sample was immersed in the fluid. The film systems with AFR700B adhesive gained less weight (Table 8), indicating that they are more resistant to the chemical change caused by degreasing solvent than those with FM680-1 adhesive.

Table 8. EFFECT OF DS-108 CLEANING SOLVENT EXPOSURE

(HOURS)	PERCENT WEIGHT GAIN BY CANDIDATE FILM/ADHESIVE SYSTEM ^{a)}			
	PFPI/AFR700B	PFPI/FM680-1	FPE-265/AFR700B	FPE-265/FM680-1
24	0.9	7.4	2.1	8.0
48	0.9	3.3	1.4	4.8
120	2.5	7.5	2.2	6.7
168	2.7	6.3	1.8	5.4

^{a)} Average of duplicate samples

3.3 HUMIDITY AGING AT 90°C/95% RELATIVE HUMIDITY

A crucial environmental assessment involves the effect of combined high temperature (i.e., 90°C) and high humidity (i.e., 95% RH) as the “worst case” in which the film materials may normally encounter. Kapton[®] is known to be moisture sensitive (Ref. 3), which casts some doubts on the general humidity resistance of polyimides.

The humidity aging test results obtained after 1000 hours exposure at 90°C/95% RH on system candidates, plus the Kapton[®] film control (data obtained from Ref. 3), are presented in Table 9. The PFPI system candidates showed less than 1% weight change at the end of the exposure period, remained very flexible or “tough” upon flexing and bending, and possessed no tackiness on touching. In contrast, The FPE-265 system candidate became severely darkened at about 264 hours of humidity aging, and Kapton[®] film became very tacky after 324 hours (Ref. 3).

These humidity test results, combined with the isothermal aging test results, strongly support that PFPI system candidates are more stable than the FPE-265 (an aromatic polyester) system candidates. The DS-108 immersion test results clearly identify that AFR700B is chemically more compatible with the degreasing agent than the FM680-1. Hence, PFPI/AFR700B was selected as the key film/adhesive system in this study.

Table 9. EFFECT OF 90°C/95% RH AGING

AGING DURATION (HOUR)	PERCENT WEIGHT LOSS(-) OR WEIGHT GAIN (+) BY CANDIDATE FILM/ADHESIVE SYSTEM ^{a)}				
	PFPI/AFR700B	PFPI/FM680-1	FPE-265/AFR700B	FPE-265/FM680-1	KAPTON® FILM
24	-0.9	-0.1	+1.1	-1.6	-
48	-0.9	-0.1	+1.0	-2.1	-2.1
120	-0.9	-0.1	+1.1	-2.6	-2.0
264	-0.9	-0.1	+1.0 ^{b)}	-2.8 ^{b)}	-2.2
528	-0.9	-0.1	+1.2	-2.4	c)
768	-0.8	-0.1	+0.1	-3.3	-
1000	-0.7	-0.1	+0.3	-3.3	-

a) Average of duplicate samples

b) Onset of severe sample darkening

c) Sample developed surface tackiness and weight change could not be obtained (Ref.3)

3.4 ELECTRICAL TESTING OF EXPOSED SYSTEM SAMPLES

Samples of exposed system samples, along with controls (system and film), were forwarded to Wright Lab for electrical testing. This arrangement was necessary due to problem encountered at Lawrence Technology, especially with the breakdown and dry arc-tracking measurements. Full electrical property characterization of the system samples has not been completed, but TRW is confident that the results would validate the selection of PFPI/AFR700B as the final system candidate.

4.0 TASK 3 EXPERIMENTATION

Task 3, Initial Wire Insulation and Testing, aims to:

1. process 2000 to 3000 feet of 1-foot wide continuous PFPI/AFR700B film in rolls, and
2. wrap sufficient quantity of 20 AWG copper wire with PFPI/AFR700B insulation for subsequent testing as insulated wire.

Each of the experimental areas listed above is separately described below.

4.1 CONTINUOUS CASTING OF PFPI FILM MATERIAL

To prove the feasibility of producing PFPI/AFR700B insulated wire, it is necessary to produce continuous PFPI film in rolls using a commercial process. Unlike commercial film material, such as Kapton[®], Upilex[®], and FPE-265, PFPI is only available from the vendor as a varnish. While defect-free films have been cast in the laboratory in the size of about 1' x 1', films of similar quality have yet to be demonstrated by a commercial process.

Several commercial processes, including melt extrusion, aqueous dispersion powder technology and solution cast process, have been utilized to produce polyimide films. We contracted the Rexam Corporation (formerly Rexham), Industrial Products Division, to conduct a small-scale continuous solution process casting of the film. Prior to conducting the film casting activities at Rexam, the following key decisions were made based on past program experience or screening experiments conducted at TRW:

- Web Selection - The selection of webbing material for casting of PFPI film depends on the maximum processing temperature and the ability of cast film to release from the web. The temperature for the complete cure of PFPI is 700°F, well beyond the temperature capability (400°F) of the multi-zone oven at Rexam. The 400°F web candidates are Mylar[®] (a thermally stabilized polyester) film and Kapton[®] film. A film drying experiment was performed at TRW. The screening tests (Table 10) show that PFPI could not be released from Kapton[®] after heating the cast film on Kapton[®] web at temperatures as low as 250°F (Run # 17). On the other hand, drying of cast film

on Mylar[®] web is limited to 300°F (Run #18 and Run #18-1) because of the lower thermal stability of Mylar[®].

Table 10. PFPI FILM DRYING TEST

RUN	WEB THICKNESS (MIL)		TIME (MINUTE) AT TEMP, °F				RELEASED FROM WEB
	MYLAR [®]	KAPTON [®]	250	300	350	400	
13	2		4	4	4	4	NO
14		3	4	4	4	4	NO
15	7		4	4	4	4	NO
16	7		8				YES
17		3	8				NO
18	7		4	4			YES
18-1	7		4	4	4		NO
19 ^{a)}		3			4	4	YES
20	7		8	8			YES ^{b)}
21	7		8	4			YES
22	7		8	4	4 ^{c)}	4 ^{c)}	GOOD FILM

^{a)} Used film from Run #18 film and replaced Mylar[®] web with Kapton[®] web

^{b)} Not as easily as Run #18 to release film from web

^{c)} Film was treated at 350°F and 400°F without web

An alternate process was developed (Run #22) in which PFPI was treated at temperatures up to 400°F to attain low residual solvent content. The process involved the drying of PFPI cast on Mylar[®] web in two low temperature cycles, 250°F for 8 minutes and 300°F for 4 minutes. The subsequent higher temperature drying (4

minutes each at 350°F and 400°F) was completed with free-standing PFPI film after removing the Mylar® web. The Fourier Transform Infrared (FTIR) spectrum of Run #22 film (Figure 8) shows that the film is partially imidized. The additional passes of Run #22 heating schedule would increase the % solid content of the film.

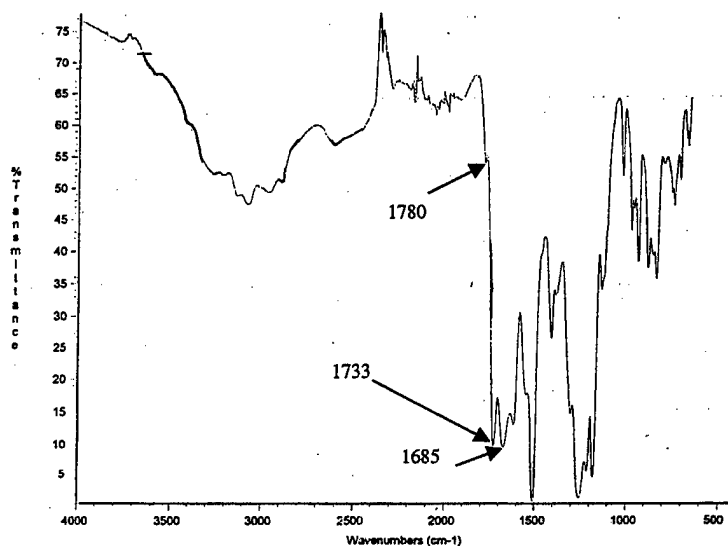

(a) Partially Cured Film (Run #22 in Table 10)

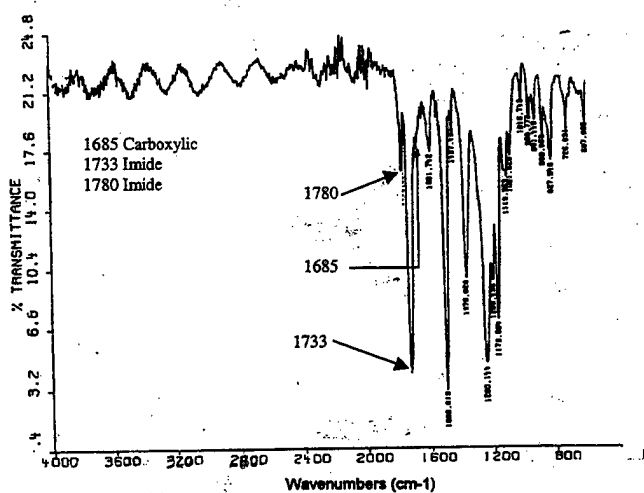

(b) Fully Cured Film

Figure 8. FTIR Spectra of Laboratory Prepared PFPI Films

Based on the results, it was decided that PFPI would be cast on 5 mil Mylar® web,

dried with Mylar[®] at temperatures up to 300°F, and further dried as a free standing film for temperatures above 300°F.

- Co-imidization of PFPI and AFR700B - Since the cast film would not be fully imidized prior to the casting of AFR700B adhesive layer due to the 400°F maximum oven limit, a screening test was also conducted to evaluate the feasibility of co-imidizing film and adhesive after the casting of AFR700B. The AFR700B resin was coated onto a cast PFPI film which had been dried at 400°F. The film/adhesive tape was then treated at 250°F to remove solvents. Visual inspection of the adhesive indicated that it might be too dry as evidenced by the cracking of the adhesive layer. The coated tape was used to wrap a bare copper wire and post-cured at 700°F. The wrapped wire showed adequate adhesive flow and acceptable bonding between layers. The results indicated that co-imidization of PFPI and AFR700B is feasible.
- Drying schedule of AFR700B - Experimental work was conducted to determine the proper drying cycle of AFR700B. The run #22 PFPI film was coated with adhesive and followed by drying in 100°F, 125°F, 150°F and 175°F oven for 4 minutes each to remove methanol solvent. The adhesive was still slightly tacky to touch. The heating scheme was deemed acceptable for drying of AFR700B prior to rewinding.
- Process development for film casting - Samples of PFPI and AFR700B varnishes were evaluated at Rexam for the optimum viscosity for processing films. Preliminary evaluation indicated that the PFPI should be diluted to a starting viscosity of 10 poises in the mixer tank.

Based on the results of the screening tests conducted at TRW and Rexam, a trailblazer process plan (Figure 9) was devised to guide the PFPI/AFR700B production run. The PFPI casting run was conducted in June 1995. The PFPI film was cast on a pilot coater (Figure 10), equipped with a modified Faustel slot-die caster with a new slot design, and operating at a throughput rate range of 6 to 20 feet/min. Rexam had performed several PFPI coating experiments to identify the conditions for casting film with uniform thickness as well as free of blisters and other defects. The PFPI was eventually cast at

a 12-inch width on a continuously-fed 18-inch width x 5-mil thick Mylar® web. PFPI was cast as the polyamic-acid precursor at about 14.8% polymer solids loading by weight in NMP solvent. The solution viscosity was measured at 10.5 poises. The PFPI coating was fed at a pump speed of 20 RPM and a roller speed of 10 feet per minute.

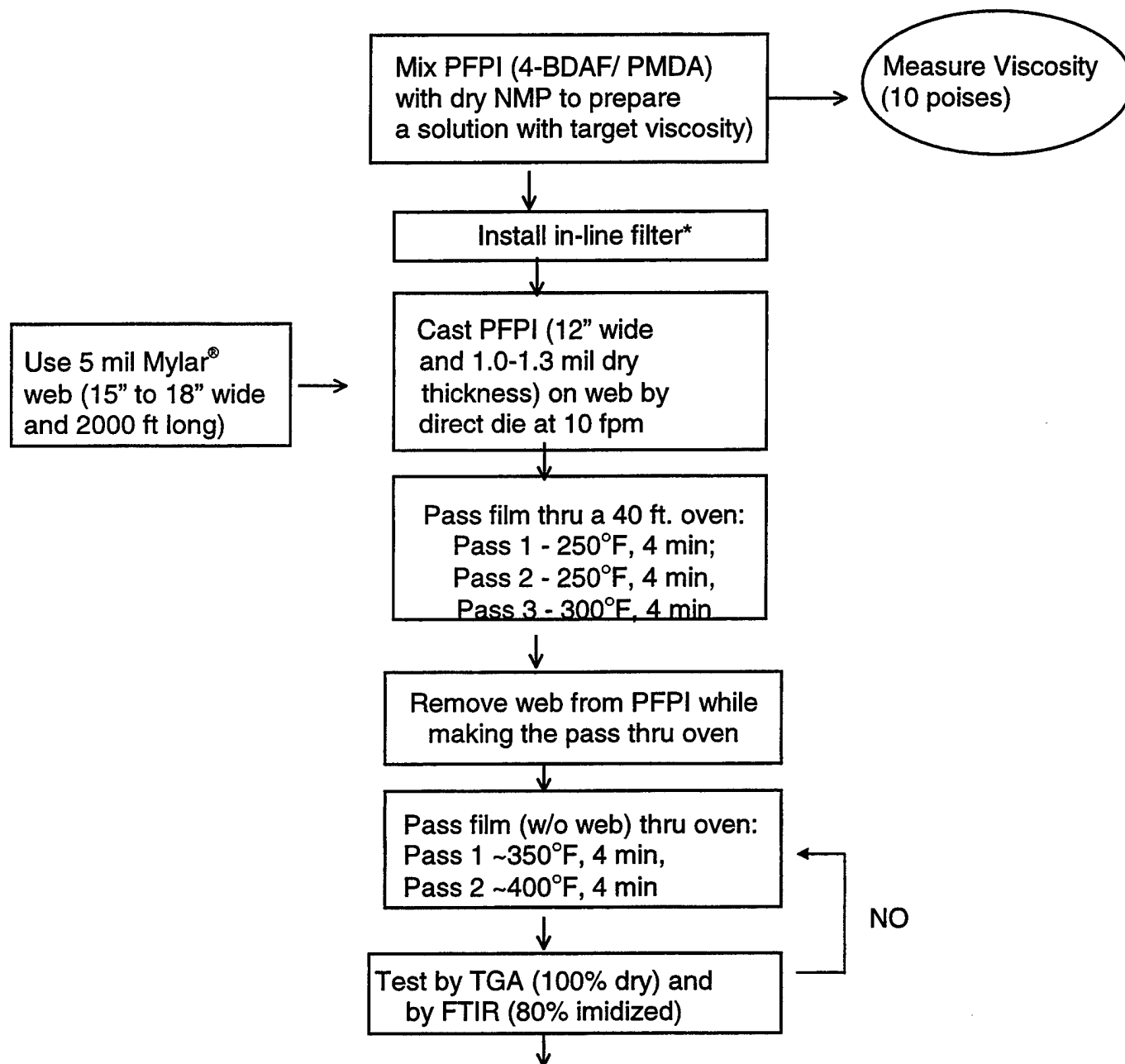

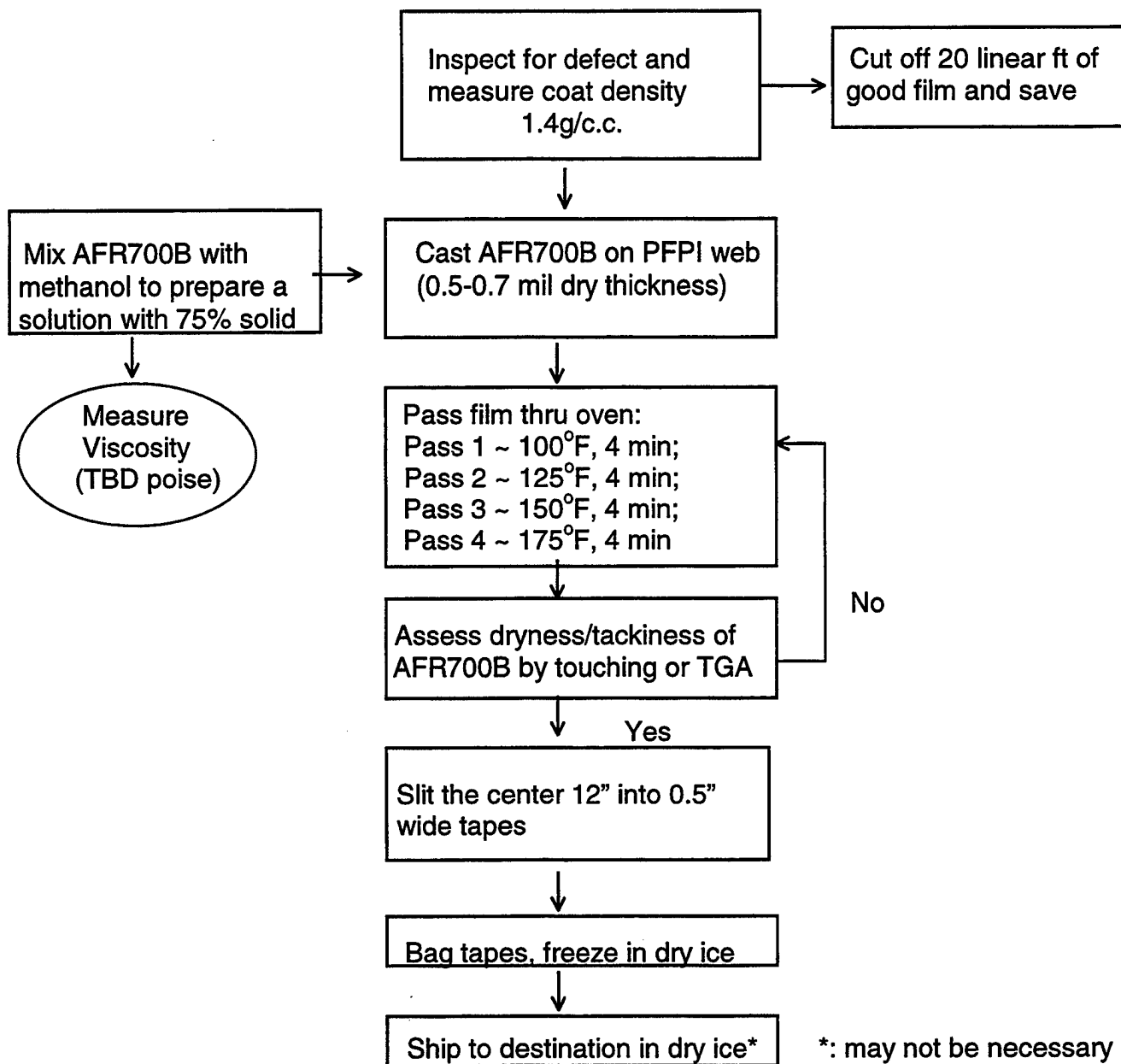
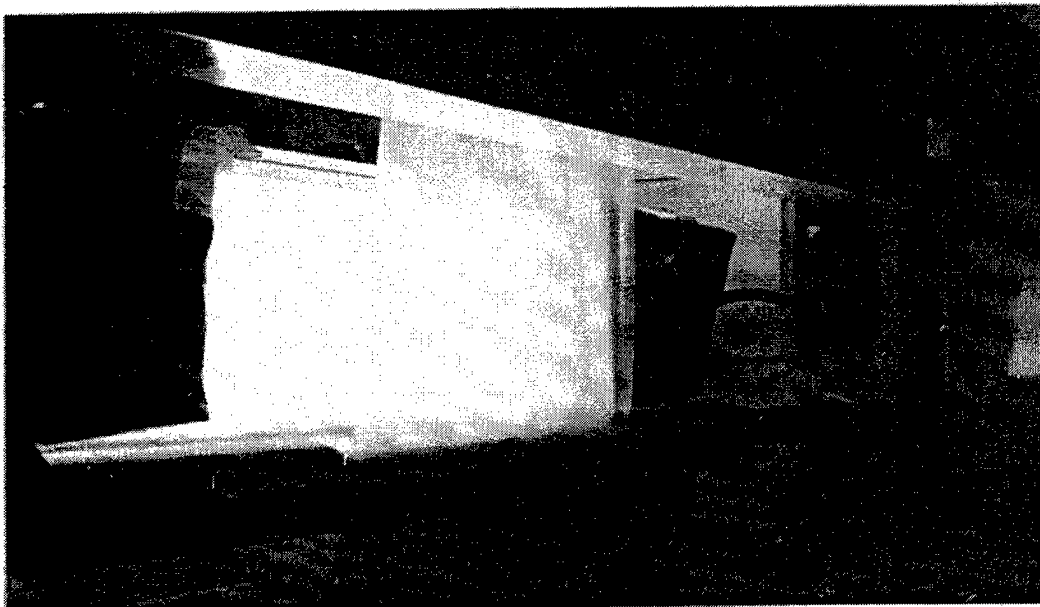
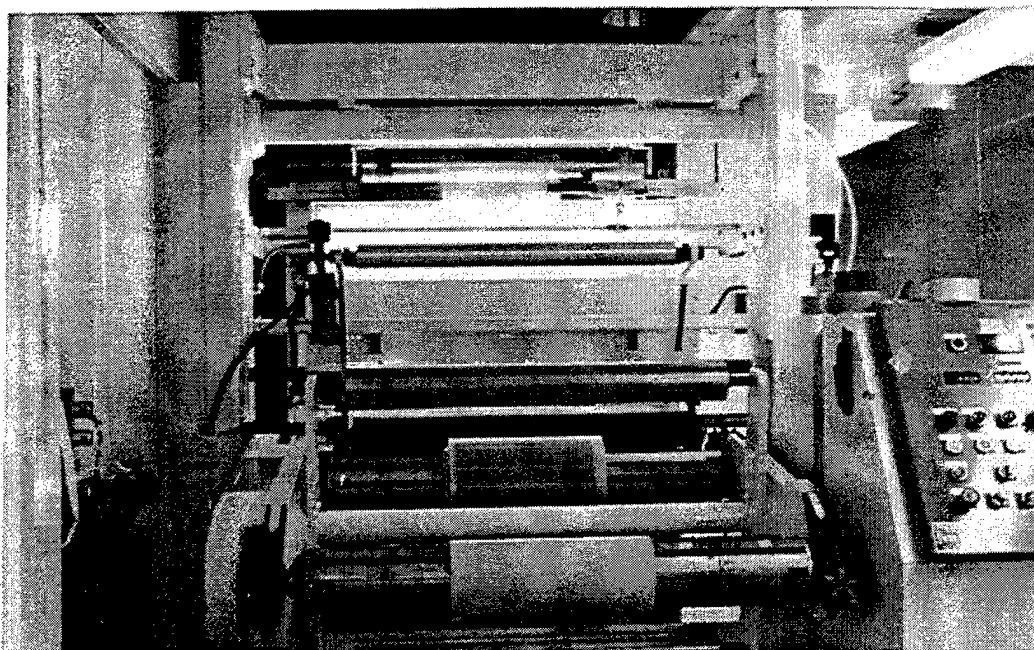

Figure 9. Trailblazer Study Plan

The cast film was dried in-line with four zones of forced air heating to attain a 400°F maximum temperature. The total length of the oven was 40 feet. For the first pass of oven drying during the PFPI coating run, the temperature and air flow for the different zones are shown in Table 11.



(a) 40 feet Drying Oven



(b) Pilot Coater Control

Figure 10. Casting PFPI Film at Rexam

Table 11. PFPI FILM PROCESS TEMPERATURES AND AIR FLOWS

Zone	Temperature (°F)	Air Flow (SCFM)
1	250	712
2	300	789
3	350	1060
4	350	1993

The coating of PFPI on the Mylar[®] web and the first pass drying were successful. Three rolls of 12-inch wide PFPI film with 1000, 1500 and 800 feet lengths, respectively, were coated. These films were very smooth and had minimal defects and, after the first pass drying, were readily separated from the Mylar[®] web and measured to be 1.2 mils thick. Thermogravimetric analysis (TGA) of the “first-pass” PFPI film showed a 20% weight loss upon heating the film from ambient to 500°F (Figure 11a). This weight loss results from the removal of NMP solvent and the byproducts of imidization reaction.

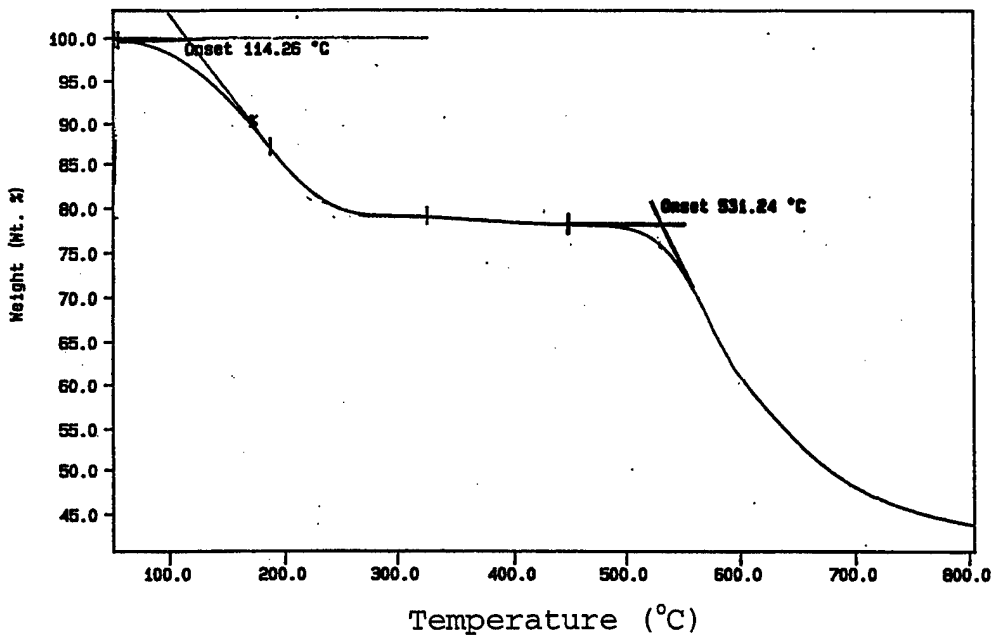

(a) First-pass Film

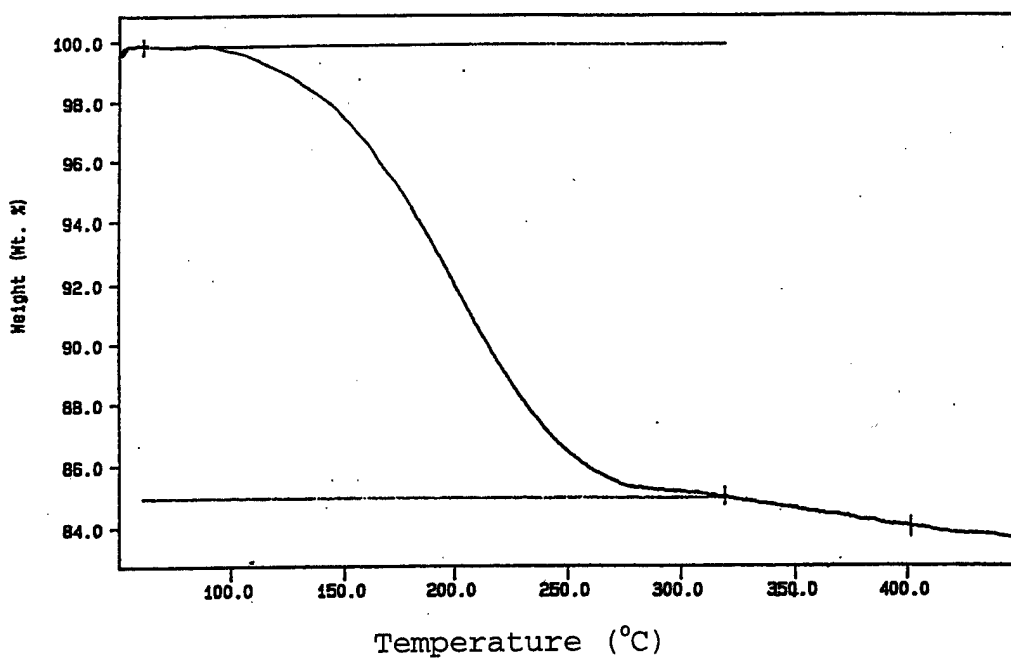

(b) Second-pass Film

Figure 11. Typical TGA Profiles of Rexam-cast PFPI Films

The FTIR spectrum of the “first-pass” film is shown in Figure 12a. The extent of imidization for the “first-pass” film was similar to that of the laboratory prepared, partially cured PFPI film shown in Figure 8a. The extent of imidization is estimated, by comparing the ratio of the 1733 cm^{-1} peak (imide band) to the 1685 cm^{-1} peak (carboxylic acid band) to the peak ratio of a post-cured PFPI film, as 35% imidized after the first pass.

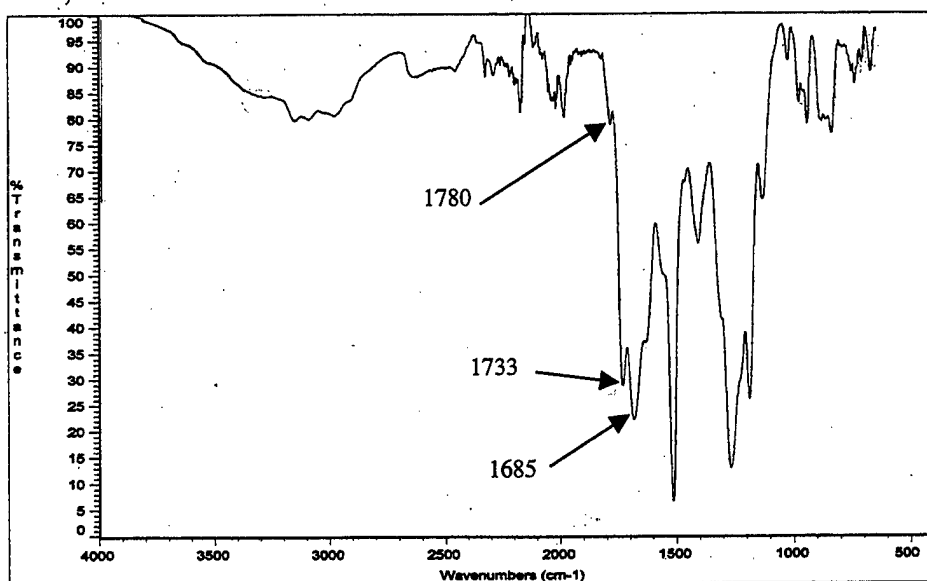

(a) First-pass Film

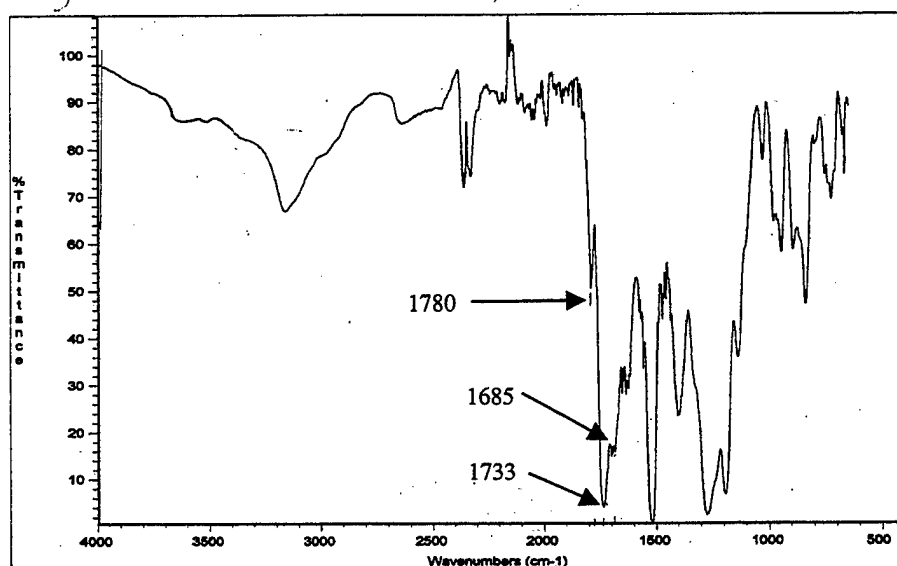

(b) Second-pass Film

Figure 12. FTIR Spectra of Rexam-cast PFPI Films

The objective of the second day at Rexam was to complete the drying of the three rolls of PFPI film cast on the previous day. Complete drying of the PFPI film is critical to minimize deterioration in film quality during the final cure step. Several "second pass" trial runs

were conducted to dry the "first pass" film. The trial runs covered the following process conditions:

- Drying film with and without Mylar® web
- Adjusting roller speed from 5 feet per minute to 10 feet per minute
- Controlling the oven temperature between 350°F and 400°F for all four zones.
- Reducing the winding tension with a portable winder

In most cases, the film became brittle after the second pass and easily cracked as it came out of the oven. The "better" second-pass result was obtained by passing the film with Mylar® web at 350°F oven temperature and 10 feet per minute in roller speed. Still, the film curled badly as it exited from the oven. Estimation from the TGA and FTIR results in Figure 11b and Figure 12b shows that the film had experienced a 15% weight loss (or solvent content) and was about 80% imidized. The second pass also shrank film width from 12" to 10.5", and film thickness from 1.2 mil to 0.9 mil when compared to the first-pass film. The shrinkage was roughly about 25%.

About 2000 feet of the initial 3300 feet of film cast on the first day was consumed on the numerous second-pass drying attempts. The excessive wastage was unavoidable because 200-300 feet of the coated film was spent per pass. Since there was little success in drying the first-pass film, the plan to cast AFR700B polymer precursor onto a dried PFPI film was terminated. The remaining 1300 feet of film was packaged in 4 different rolls, purged with nitrogen, and shipped to TRW. Additional details on the casting and drying of PFPI film were described in the Rexam Report (see Appendix).

The PFPI drying problem was briefly studied. Some of the plausible causes were identified as follows:

- The PFPI resin used at Rexam might have degraded - The PFPI varnish was purchased in June 1994 and was in cold storage for about a year before it was cast into film in June 1995. The shelf life of the varnish is about one year. The resin might have degraded or prematurely polymerized prior to the film casting. The molecular

weight of the Rexam-cast film may be substantially lower than that of the laboratory prepared film.

- PFPI film may be inherently brittle – The first-pass film had roughly 20% of residual NMP, which plasticizes the film. The additional drying pass, which removed about 5% more, was sufficient for film embrittlement to occur.
- Film embrittlement might also be induced by a combination of thermal and mechanical over-stresses exerted on the Rexam film during processing. The winding tension of the rollers of the pilot coater and the rapid heating/cooling are potential sources of processing stresses. Tough PFPI films have been prepared in a batch scale in the laboratory with obviously much less induced stresses. The film embrittlement may be due to the deviations from the casting and drying steps used in the laboratory. These deviations might have deleterious effects on the toughness of the cast film.

Several 12"x10" sheets of first pass PFPI film (about 35% imidized) and second pass film (about 80% imidized) were processed at TRW to determine whether the Rexam-cast film could still be salvaged through continual processing of these films into usable tapes for wire wrapping. After several attempts, a Rexam-cast film was successfully cured with acceptable quality using the following "low-stress" heating schedule:

- Heat in the film in a convection oven at 200°F for 1 hour, followed by 30 minutes at 300°F.
- Turn film over and cure at 300°F for 30 minutes, 400°F for 1 hour, 500°F for 1 hour, 600°F for 1 hour, and finally 700°F for 1 hour.
- Avoid exposing films to direct convective air flow during heating.

The cured film was very smooth and had minimal defects based on visual inspection. The FTIR spectrum of the cured film is identical to that of the fully cured laboratory prepared film (see Figure 8b). The absence of 1685 cm^{-1} (the carboxylic acid band) verifies that the film was completely cured. Similar efforts were also attempted to cure the second pass films. Numerous small cracks were found on the cured films. The difference between first-

pass and second-pass is apt to be caused by additional stresses from the second passing of the PFPI film. It was concluded that the first pass films were still amenable to processing into acceptable quality film.

The dried Rexam-cast PFPI film sample was forwarded to Foster Miller for electrical property test. The ac breakdown voltage was 6300 volts per mil for both room-temperature and 200°C. This level of breakdown voltage met the wiring needs even at 200°C according to Foster Miller. These results are in agreement to those reported by Lawrence Technology for the laboratory prepared PFPI film (Table 5 or Reference 3, i.e., 6300 and 6800 volts per mil breakdown voltage at room temperature and 3200 volts per mil at 300°C).

4.2 FILM DRYING WITH HOT PLATE OVEN

An initial attempt was made to locate an outside facility with 700°F oven capability to fully cure the Rexam-cast film. Several facilities were contacted, including Bertek in Vermont with oven capability up to 450°F at 5 feet per minute and Barcel at Irvine, CA with tower furnace capabilities up to 800°F for processing dip-coated wire. Since TRW was unable to locate a suitable facility for drying 12" wide film, it became necessary to cure the Rexam-cast film in-house.

A parallel plate oven with 800°F heating capability was set up at TRW to continue the processing of the first-pass Rexam-cast film. A schematic and photographs of the continuous processing oven are shown in Figure 13 and 14, respectively. Several pieces of Rexam-cast film were processed in batches with different heating schedules to determine the processing parameters. The successful heating schedule, which produced a cured film with no visual cracks, utilized a small incremental increase in temperature (between 75 and 100°F), and is listed in Table 12.

Top View

CONTINUOUS DRYING AND CURING OF PFPI FILM

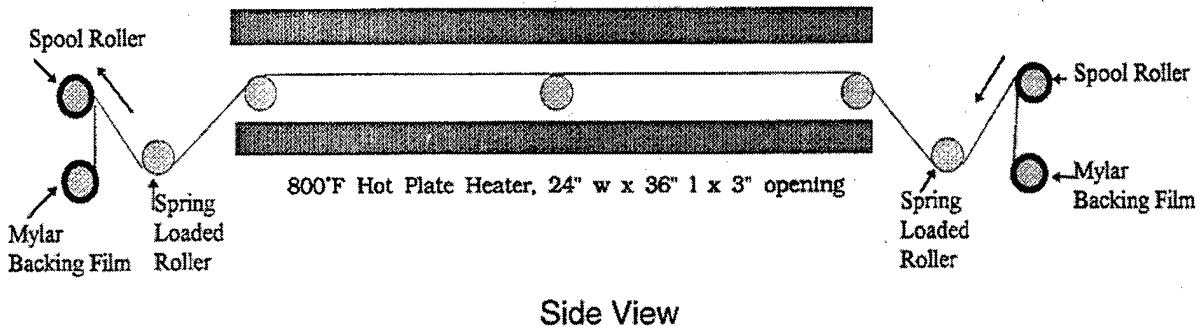
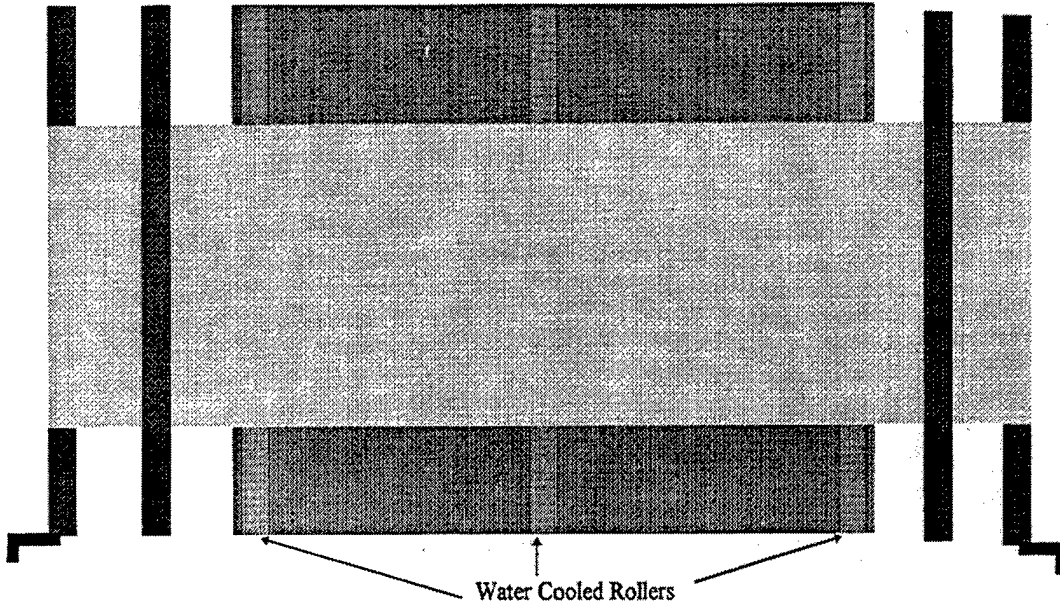
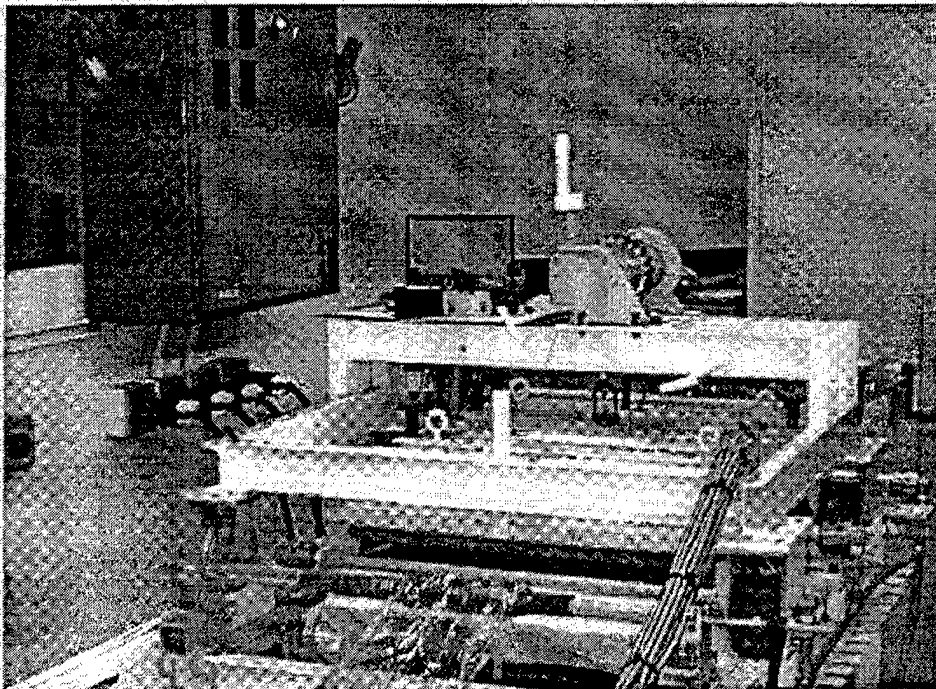
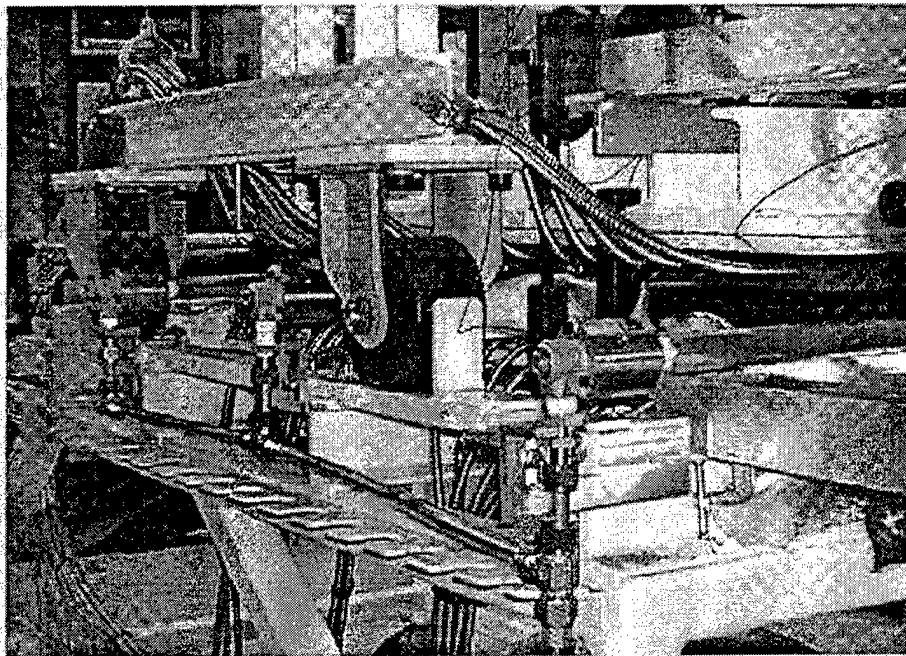

Figure 13. Schematic of Continuous Film Processing Oven



(a) Top View



(b) Side View

Figure 14. Photographs of the Continuous Film Processing Oven

Table 12. OPTIMIZED HEATING SCHEDULE

Temperature set (°F)	Actual Temperature within the Plate Heater (°F)	Number of Passes at Temperature
300	250	1
400	300	2
500	375	1
600	450	1
700	550	2
800	600	3
850	710	3

The film speed was about 10 feet per minute. The absence of the 1685 cm^{-1} peak in FTIR spectrum of the processed film (Figure 15) shows the film was fully imidized. Trial process runs at higher incremental temperature increase resulted in the scorching of the films.

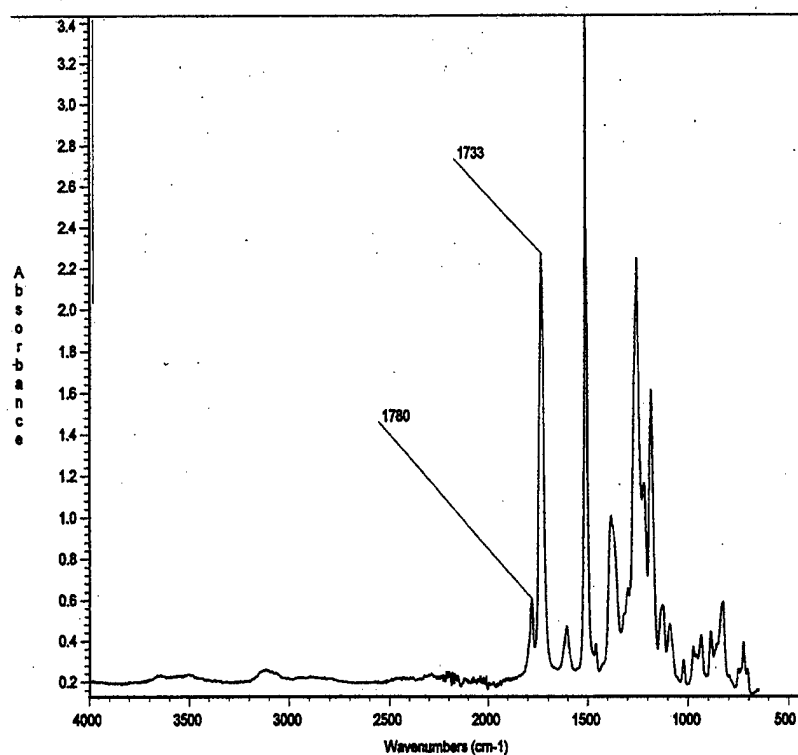

Figure 15. FTIR Spectrum of Rexam-cast Film Cured in Continuous Oven

The next step was to modify the parallel plate oven for continuous processing of the Rexam-cast film. Three water-cooled rollers were installed between the hot plates at different locations (entrance, mid-section and exit). Two spring-loaded rollers were installed outside the entrance and the exit of the hot plate oven for spooling and re-spooling of the film. These modifications were intended to process the PFPI film without any web and to provide the right level of winding tension during processing. Initial trial runs with various web materials had shown that PFPI film will adhere (or weld) readily to Kapton[®] film and aluminum foil at high temperatures, and Mylar[®] is not stable at temperatures above 300°F. Excessive winding tension on the free-standing film during processing would lead to curling and cracking emanating from the edges; insufficient tension would lead to film contacting of hot plates due to sagging.

Several runs, each involving drying and rewinding of film without web, were made with the second pass film using the modified oven. Each run required about 60 feet of Rexam-cast film and was processed in accordance with the heating schedule in Table 12. However, multiple passes through the oven caused the films to curl in the edge in increased severity, and repeated winding and rewinding operation initiated cracks along the curled edge, eventually propagating through the width of the film. This problem is believed to reflect film shrinkage during heating and non-uniformity in tension across the film width during winding.

Attempts were made to improve the quality of the dried film by a combination of varying the level of winding tension and increasing the number of passes at lower temperatures (below 400°F) to strengthen the film prior to cure at higher temperatures. Each case only resulted in cracked and wrinkled films, and attempts to repair the cracks with Kapton[®] tape in order to continue the heat treatment likewise only afforded dried but wrinkled film. It was obvious that a fully cured PFPI film with acceptable quality could not be achieved with the laboratory-type equipment.

4.3 SPRAY COATING OF PFPI FILM WITH AFR700B

The plan at this point was to investigate the method of coating Rexam-cast film in the

partially dried condition with AFR700B adhesive. The coated film would then be cut into strips for wire wrapping. It was envisioned that the drying of PFPI and co-curing with AFR700B should take place during the final heat treatment of wrapped wire. A winding fixture was set up in a spraying booth for the spray coating of PFPI film.

Screening experiments were initiated to determine the spraying parameters, such as solid loading and drying schedule, prior to actual spraying on the PFPI film. The adhesive at a loading of 75% solids in methanol (as received) was applied onto PFPI film with a brush, and the coated films were dried in an oven at temperatures up to 200°F in accordance with the heat cycles given in Table 13.

Table 13. EFFECT OF HEATING CONDITIONS ON PFPI/AFR700B FILM

Heat Cycle	Observations
5 minutes at 200°F	Numerous bubbles and flaking
1 minute at 200°F	Numerous bubbles and flaking
5 minutes at 170°F	Finer bubbles
5 minutes at 150°F	Bubbles
30 minutes at 120°F	No bubbles
5 minutes at 100°F and 1 minute at 200°F	Bubbles and flaking
2 hours at 100°F and 1 minute at 200°F	Bubbles

In all cases, the adhesive-coated film did not stick to each other. This indicates the coated film would be able to be rewound after spraying without sticking to the mating surface. It was also apparent that the coating must be applied in very thin layers to avoid bubble formation and patchy resin deposits with variable thickness. The coating must also be dried at low temperatures to avoid flaking off. The brush coating experiment was discontinued since it could not reproduce the atomization effect of spraying to rapidly remove the methanol solvent in the adhesive, and because films produced by brushing are much thicker than desired.

To coat 0.5 mil of AFR700B resin on PFPI film, the as-received AFR700B resin was diluted with methanol or other solvents (acetone, methyl isobutyl ketone and xylene) at

various concentrations (1:1 and 1:3 in adhesive-to-solvent ratios) to reduce the viscosity for spraying. Atomization causes the solvent in the resin mixture to evaporate off instead of depositing on the film substrate, therefore the low temperature (200°F) drying step is no longer needed.

The coated films were examined visually. The film prepared with 1:1 adhesive-to-solvent ratio had a grainy or powdery texture, while that prepared with 1:3 ratio had a fine, smooth appearance and was slightly tacky to touch. Further attempts to enhance the coating quality by adding small amounts (0.5 volume percent) of acetone or xylene to the 1:3 ratio mixture resulted in a patchy coating on the film. The problem might be due to phase separation during spraying. The 1:3 resin-to-methanol combination was thus chosen as the standard spraying mixture.

Another concern was whether the newly coated film would stick to the back of the Mylar[®] web during re-spooling. Testing was performed with coated film and Mylar[®] under constant compression load to simulate the rewind condition. After 24 hours of compression, the film was readily removed from the Mylar[®] with minimal transfer of adhesive powder to the mating Mylar[®] surface. The alternative approach of spray-coating the Rexam-cast film in the partially dried condition with AFR700B adhesive appeared to be workable.

4.4 WIRE WRAPPING EXPERIMENTS

The next step was to investigate the feasibility of slitting this partially dried film system into tape and wrapping onto conductor wire. Experiments were conducted to assess the factors that could impact the quality of insulated wire such as:

- Residual stress level in the film prior to wrapping
- Degree of dryness in the cast film
- Heating cycle
- Aging of sprayed coating on the film prior to wrapping

The typical test procedure for the wire wrapping experiment first involved spray-coating of

Rexam-cast film (which had undergone one-pass or two-pass through the flow oven at Rexam) with AFR700B resin mixture (mixed with 1:3 ratio of resin to methanol). The coated film on Mylar[®] web was then slit into 0.25 inches wide strips for wire wrapping using a razor blade. A 16 AWG MIL-W-16878/4 Type E stranded silver-coated conductor, with the TFE Teflon insulation stripped off, was used for the experiments. The configuration of doubly wrapped wire with coated PFPI is depicted in Figure 16. The first layer was wrapped at 45 degrees with half the width overlapped and the second layer was wrapped similarly except starting at opposite direction to form a +45/-45 stacking. To prevent the insulation from uncoiling during heating, both ends of the insulation were secured to the wire by wrapping with a small strip of the Kapton[®]/FEP adhesive tape. The test samples were hung on a test fixture and heated in a convection oven using the standard cure cycle. Following film cure, the insulated wire was examined under a microscope for insulation cracks, adhesive extrusion, blisters, trapped bubbles, and cracks along the overlap.

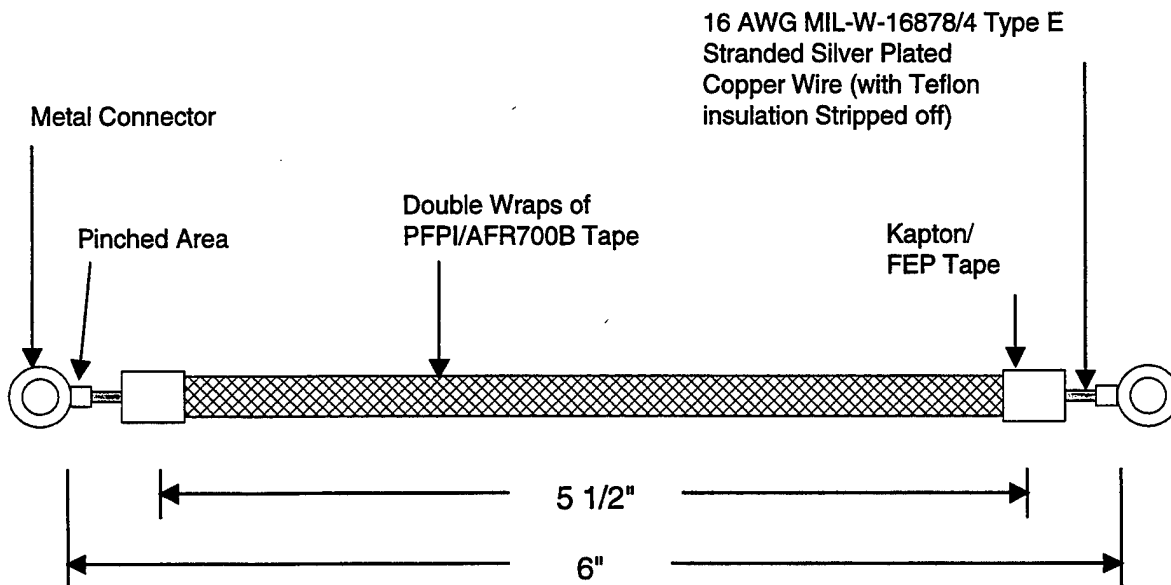

Figure 16. Configuration of Wire Wrapping Test Sample

The results of the first wire wrapping experiment (Runs A through C) are shown in Table 14. Both partially imidized film, with or without 1 month of storage (Run A and B) cracked on wires, and the effect of storage is thus unknown. Run C showed that insulation would not crack if a fully cured PFPI film is used for spray-coating with adhesive. Typical photomicrographs of films with and without cracks are shown in Figure 17.

The Rexam-cast PFPI film is only partially cured (35% cure for first-pass film according to Rexam TGA results) and any attempts to fully cure the film at TRW had been unsuccessful. The only option for salvaging the film was to determine the minimum drying needed before coating with adhesive for the insulation to withstand the thermal and mechanical stresses exerted onto the wrapped wire during the final cure.

Table 14. RESULTS OF FIRST WIRE WRAPPING EXPERIMENT

RUN	PFPI FILM CONDITION PRIOR TO SPRAY COATING ^{a)}	SPRAY-COATING ^{b)}		APPEARANCE OF WRAPPED WIRE
		PASSES	THICKNESS	
A	PARTIALLY IMIDIZED (ONE DRYING PASS) FILM	NONE	0	CRACKS
		10	0.4 MIL	CRACKS
		25	0.8 MIL	CRACKS
B	PARTIALLY IMIDIZED (ONE DRYING PASS) FILM; STORED COATED FILM IN COOLER FOR ONE MONTH	NONE	0	CRACKS
		10	---	CRACKS
		25	---	CRACKS
C	COMPLETELY CURED FILM; CURED WITH LOW RESIDUAL STRESS ^{c)}	NONE	0	NO CRACK
		10	---	NO CRACK
		25	---	NO CRACK

^{a)} Heat cycle for curing wrapped wires: 200°F for 1 hr, 400°F for 1 hr, and 500°F for 1 hr

^{b)} The AFR700B (75% solid) was diluted with methanol in 1:3 volume ratio

^{c)} Cured film with low residual stress (see heat schedule on page 35)

The second wire wrapping experiment was conducted to determine the minimum drying needed. The single-pass Rexam cast film was heat treated by progressively increasing the final temperature (from 350°F to 500°F) before spray-coating. The holding time was from 30 minutes to 1 hour of the cure cycle. The results (Table 15, Runs a through d) indicate that an additional treatment of 30 minutes at 350°F for the first-pass film would be sufficient to avoid cracking of wire insulation after wrapping.

Table 15. RESULTS OF SECOND WIRE WRAPPING EXPERIMENT

RUN	PFPI FILM CONDITION PRIOR TO SPRAY-COATING ^{a)}	SPRAY COATING PASSES ^{b)}	APPEARANCE OF WRAPPED WIRE
a	REXAM-CAST (ONE DRYING PASS) FILM	NONE 10	CRACKS CRACKS
b	SAME AS RUN a PLUS 350°F FOR 30 MIN	NONE 10	NO CRACK NO CRACK
c	SAME AS RUN b PLUS 400°F FOR 1 HR	NONE 10	NO CRACK NO CRACK
d	SAME AS RUN c PLUS 500°F FOR 1 HR	NONE 10	NO CRACK NO CRACK

a) Heat treatment for wrapped wire: 300, 400, 500, 600 and 700°F for 1 HOUR

b) The AFR700B (75% solids) was diluted with methanol in a 1:3 volume ratio

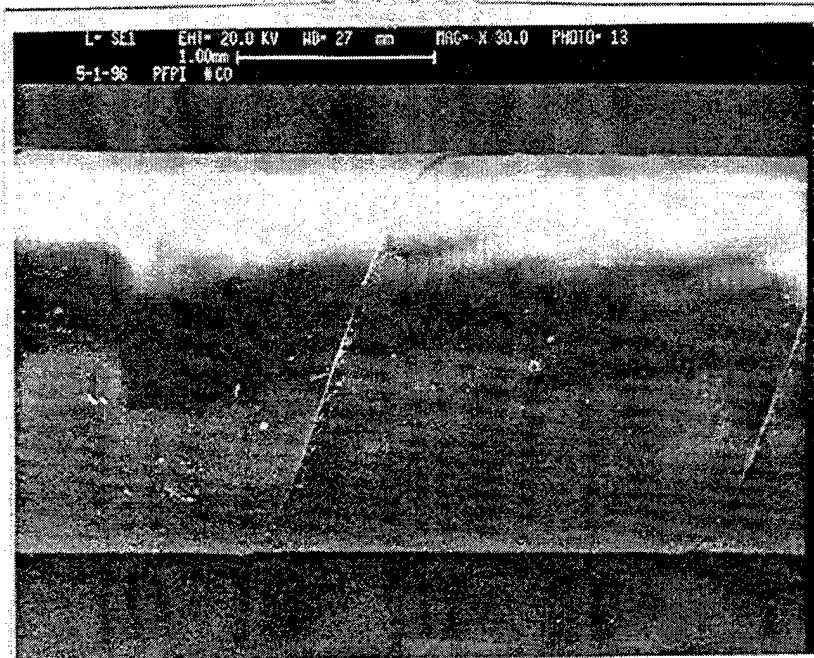

(a) Insulation without Cracks (Sample C in Table 14)

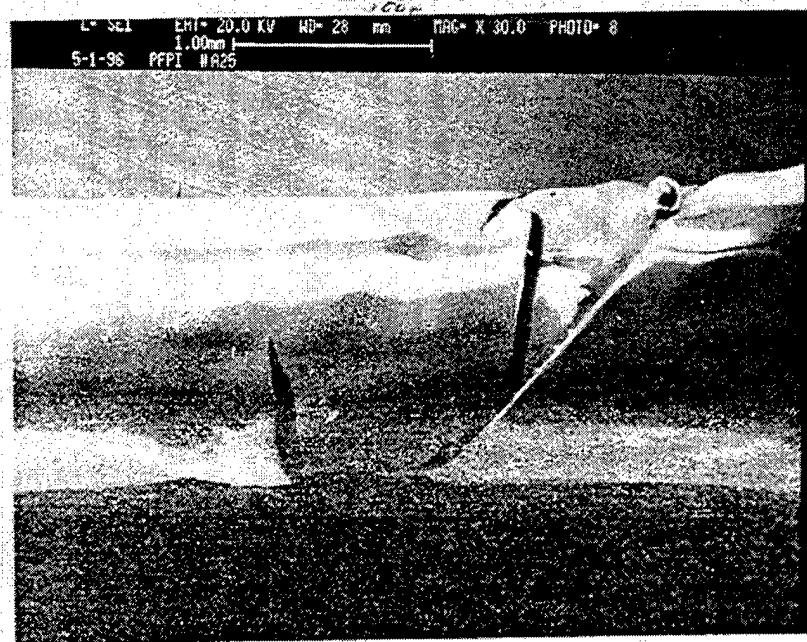

(b) Insulation with Cracks and Adhesive Bead Extruded from Sample B in Table 14

Figure 17. Photomicrographs of Heat-treated Insulated Conductors

4.5 FILM SLITTING

CommScope (formerly Teledyne Thermatics) had agreed to wrap 20 AWG MIL-W-81381 type of insulation wire using the PFPI material for TRW, but did not have the capability to precisely slit the 12 inches wide Rexam-cast film into 0.25 inches wide tape for wrapping. These slit tape segments need to be spliced together at a 45° angle using 0.5-mil Kapton®/FEP tape and rewound into full-length (or continuous) spools of coated PFPI tape (see Figure 18 for dimensional requirements for the re-spooling of finished product). Web Converting Inc. at Boston Mass., was selected for providing the slitting services.

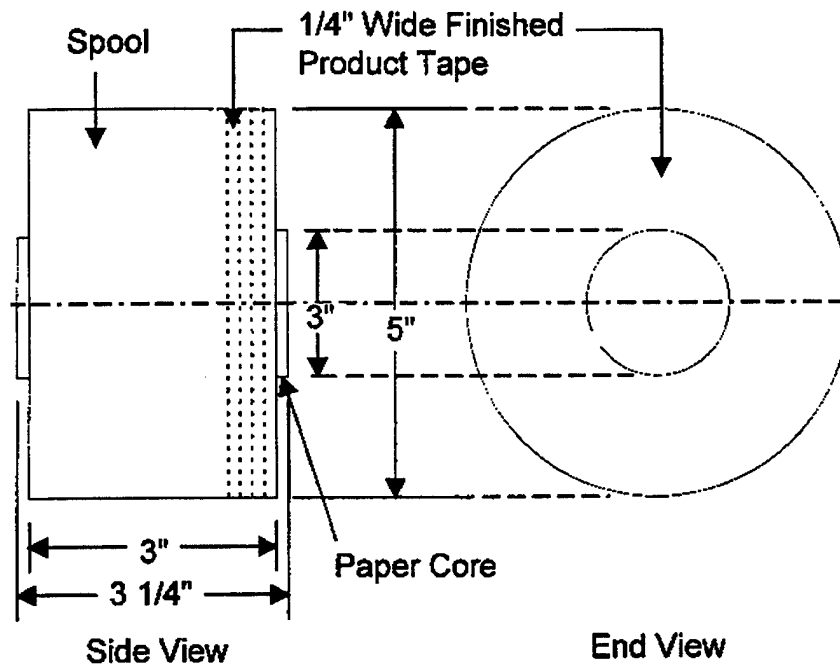

Figure 18. Core Dimension for Spooling of the Slit Tape

Two rolls of PFPI film (each contained about 450 feet of 12"-wide film) were spray-coated with AFR700B (Lot # 516401, diluted with 300% methanol) at TRW. Three passes of coating were performed and the coated film was dried briefly with hot air guns. The coated films were packed in dry ice and shipped to Web Converting Inc, which successfully converted them into two sets of slit tapes. The two sets were spooled tapes

with web (5 mil thick Mylar[®]) and without web, respectively. Each set has 23 spools of tape and each spool on the individual paper core has 450 feet of continuous tape. All of them were packed in dry ice and shipped to CommScope at Elm City, NC, except one spool from each set which was forwarded to TRW for future characterization (Figure 19).

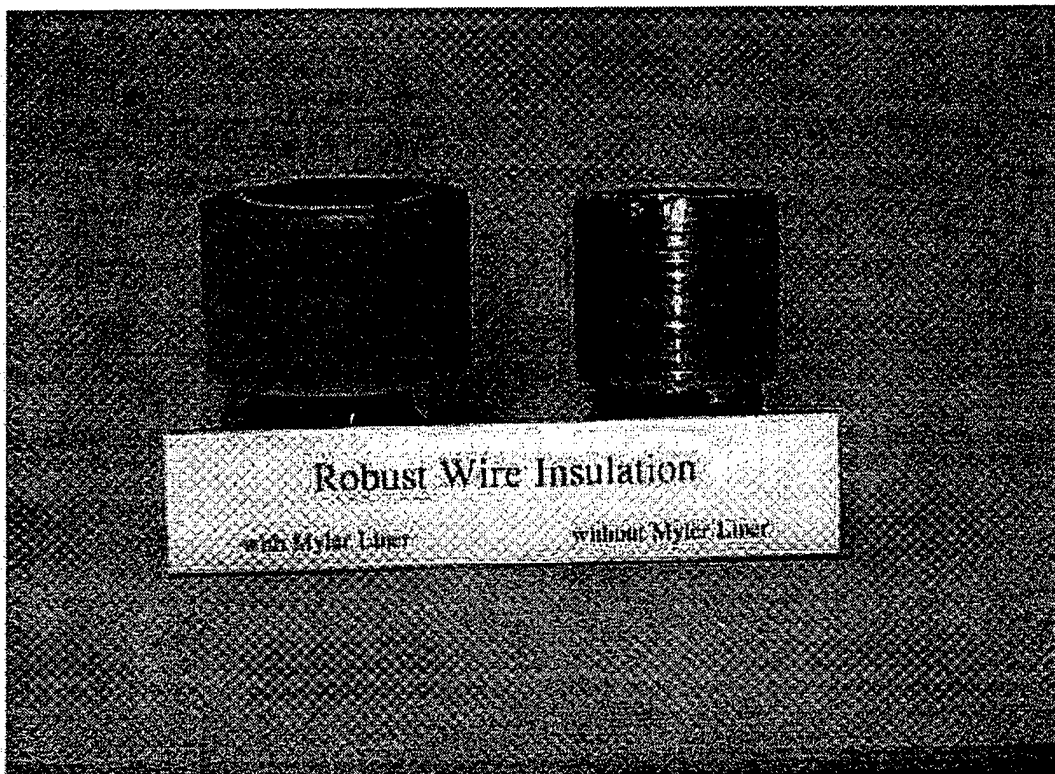
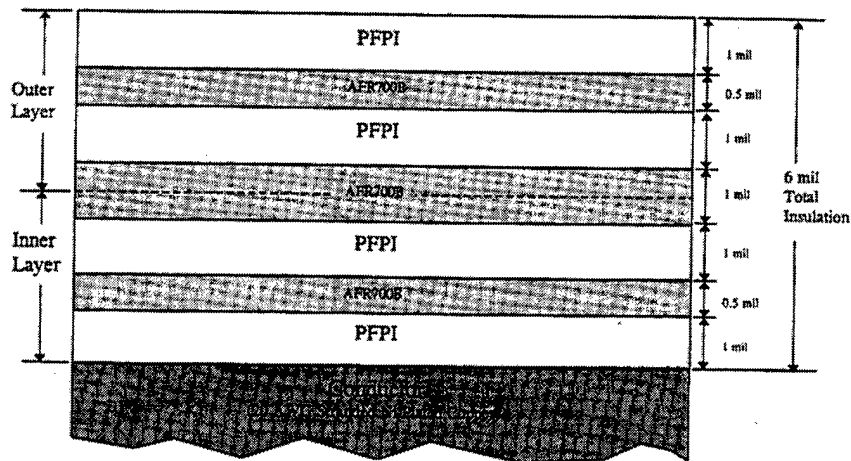

Figure 19. Samples of PFPI/AFR700B Tapes with and without Mylar[®] Web

4.6 WIRE WRAPPING

The wire wrapping development effort at CommScope targeted for a typical TKT construction (such as MIL-M-22759/91-20 in Reference 4). The fluoropolymer used in the cited TKT construction (Figure 20) is an alloy of PTFE, PFA and FEP. For the PFPI insulated wire, the conductor used was 20 AWG nickel-plated copper strand wire (NP20-1932MCD from Hudson International at Inman, SC). The inner layer and outer layer of the insulation were laid down in a single pass. Each layer consisted of a double wrap of coated tape with a 52% overwrap.



(a) PFPI/AFR700B

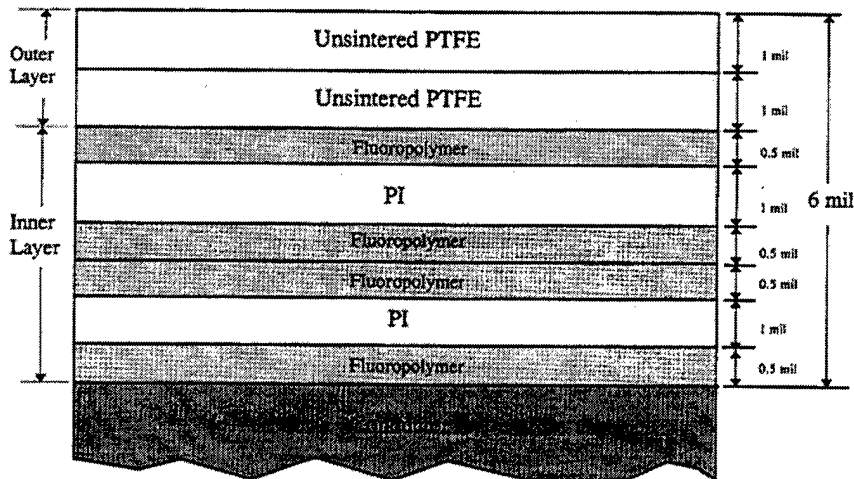

(b) TKT (MIL-M-22759/91-20)

Figure 20. Insulator Constructions for Wrapping Conductor

A key concern for wire wrapping with the partially cured PFPI tape involves its extremely low mechanical strength and the relatively high frictional drag during wrapping. Sufficient tension is needed during wrapping to avoid wrinkle formation on the wire insulation or slippage of insulation on the wrapped wire. A tensile test of a sample of the PFPI tape by CommScope reported tape breakage at about 1200 grams force, which is relatively low. Tension control was therefore paramount.

CommScope eventually identified the following key parameters in wire wrapping:

- Capstan speed (or line speed of the wire) – the speed was varied from 10 fpm (feet per minute) to 20 fpm. A speed of 17.4 fpm was selected to balance between high tensile stresses (resulted from high line speeds) and high drags (from low speeds).
- Head A (for inner layer wrapping) speed – line speed was controlled at 570 rpm to obtain 5.7 wraps per inch. The resultant tension exerted on the wrapping was varied with time between 600 to 800 gm_r.
- Head B (for outer layer wrapping) speed – line speed was controlled at 570 rpm to obtain 5.7 wraps per inch. The resultant tension was about 1000 gm_r.
- Specially designed pins – High drag was encountered during initial startup and was due to the contact of metal pin with non-uniform coating of AFR700B. Coating of the metal pins with Teflon, coupled with applying twists to the tape during wrapping, effectively reduced drag.

Roughly 2000 feet of conductor wire were wrapped using 5 spools of insulation tape. About 70% of the insulated wire (1400 feet) were acceptable (without film breakage in between) for further processing. A sample of the wrapped wire is shown in Figure 21.

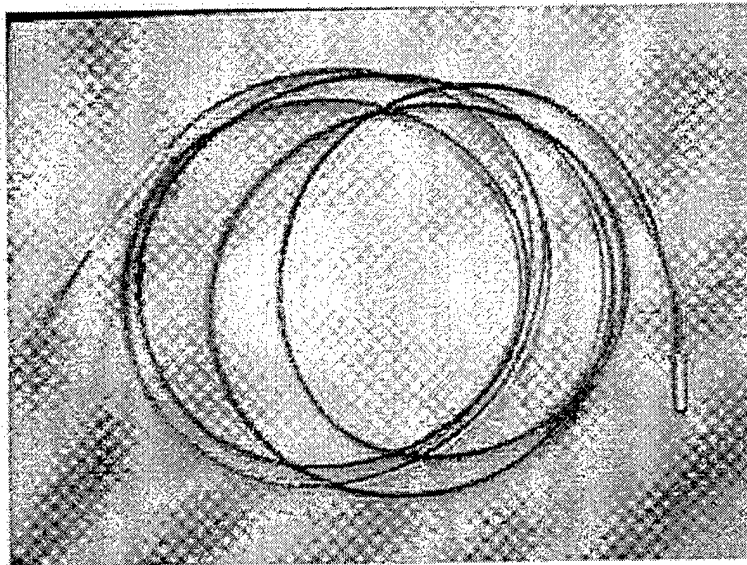

Figure 21. 20 AWG Conductor Wrapped with PFPI/AFR700B Insulation

4.7 THERMAL PROCESSING OF INSULATED WIRE

Several experiments were next performed at CommScope using the tower heater to dry and cure the insulation on the wrapped wire. Each test sample was about 5 feet long. The tower was 80 feet tall with four heating zones. All test runs caused crazes, cracks, bubbles and blisters (Table 16), which may result from expansion of the entrapped volatiles at high temperatures.

Table 16. TOWER HEATER RESULTS

TEST	LINE SPEED (fpm)	ZONE TEMPERATURE (°F)				OBSERVATIONS
		A	B	C	D	
1	20	350	500	600	750	RADIAL CRACKS; APPEARED TO BE OVER PROCESSED
2	40	350	500	600	750	RADIAL CRACKS WITH BUBBLE AND BLISTERS; TRAPPED SOLVENTS
3	70	350	500	600	750	CRACKS AND BLISTERS; WORSE THAN TESTS 1 AND 2
4	20	300	300	500	700	CRAZING; NEED TO DRY IT VERY SLOWLY TO REMOVE THE EXCESS SOLVENTS

Slow drying would allow the diffusion (or migration) of trapped residual volatiles and solvents through the multi-layer insulation. This can be achieved by heating the insulated wire at temperatures well below the boiling points of the volatiles and for longer drying time prior to curing the insulation at higher temperatures (above 350°F). Experiments were thus conducted using a topcoat tower heater that has two separate heater columns. The first heater column (15 feet long) has three heating zones (A-C) and the second column (12 feet long) has two zones (D-E). The topcoat tower allows 6 passes through the first column (each pass enters from bottom and exits from the top) prior to the single pass through the second column.

The results in Table 17 suggested the need for further experimentation with the heating schedule to minimize cracking of wire insulation upon drying. The following heating sequence was emphasized:

- Slow drying of methanol solvent (evolved from AFR700B) and moisture absorbed by the resins at about 180°F
- Slow drying of NMP solvent (evolved from PFPI) at about 350°F
- Slow heating of insulation by increasing temperature up to 750°F at 100°F intervals to achieve full cure.

Table 17. TOPCOAT TOWER HEATER RESULTS

TEST	LINE SPEED (fpm)	ZONE TEMPERATURE (°F)					OBSERVATIONS
		A	B	C	D	E	
1	40	400	460	490	520	520	CRACKS WITH TINY BUBBLES
2	30	180	200	200	180	180	APPEARED OKAY
3	15	180	200	200	350	350	APPEARED TO BE BRITTLE
4	15	180	200	200	350	550	BADLY CRACKED WITH LARGE BUBBLES
5	15	180	200	200	350	350	SLIGHTLY BETTER THAN #3
6	15	220	220	220	350	350	BEGAN TO CRACK AFTER ZONE B; NEED TO START AT LOWER TEMP

Additional experiments were completed at CommScope using the topcoat tower heater. The experiments involved heating a 5 feet long double wrapped PFPI/AFR700B wire sample by passing through the topcoat tower heater at low speed (20 fpm). The two heater columns were kept at the same temperature for each heating cycle. Each cycle

was 7 passes through two heater columns. The following heat treatment schedule was initially planned for this experiment: (1) The 180°F heat cycle, (2) The 350°F heat cycle, and (3) stepwise increase in temperatures from 400°, to 500°, to 600° and finally to 750°F.

Lateral cracks were observed at the third pass during the 350°F passes. In some segments, pieces of insulation fell off from the wire. The second test conducted at a lower temperature 300°F (instead of 350°F) did not improve the cracking problem. Effort to cure the wrapped wire was terminated. It was unlikely to yield a functional wire system for the planned wire testing for completing the Program.

4.8 CAUSES OF THE DRYING PROBLEM

The drying/imidization problem of the wrapped wire was briefly studied. Some plausible causes are:

- The viscosity or the molecular weight of the first-pass PFPI film might be too low, resulting in inadequate mechanical properties to withstand the thermal and mechanical stresses encountered during tape-wrapping and thermal processing at CommScope.
- Removal of the last traces of solvent or moisture was incomplete in the drying step. The release of these volatiles during imidization and cure at higher temperatures eventually led to insulation cracking.

The drying problem could be resolved with the use of co-solvent with NMP in the casting of PFPI. The co-solvents would facilitate the removal of the last traces of solvent by reducing the peak temperature requirement for drying. It is also necessary to identify a more compatible web for casting of PFPI film to allow drying at higher temperatures than the current limit of 300°F with Mylar® web.

5.0 CONCLUSIONS

Based upon the study results, TRW concludes:

1. The program thrust to demonstrate the high performance insulating capability of a most promising insulation candidate as a film wrapped material on copper wire has been partially achieved. The most promising candidate, PFPI using AFR700B polyimide as an adhesive to bond the film, has been shown to possess superior oxidative stability at 300°C, survivability at 90°C/100% RH, resistance to degreasing chemical, and good film-to-film adhesion:
2. PFPI film, by itself, has shown to have good dielectric loss resistance and dielectric strength at 300°C, but similar key dielectric characteristics have not been demonstrated in this study for the PFPI/AFR700B insulation system. A key concern is its low elongation-at-break, which may potentially render the system too rigid for the wire insulation application. A flexible film/adhesive system is required for the wire insulation application, and the individual components should have at least 15-20% elongation-at-break (or preferably 50% for tape-wrapping according to one vendor) and the insulated wire must be able to pass the Wrap Back test as specified in MIL STD 2233 Method 2002. The test involves the wrap back of an insulated wire to form a tightly twisted loop. The elongation-at-break was reported to be 6.3% for laboratory-prepared 1mil thick PFPI (4-BDAF/PMDA formulation) film and less than 10% for AFR700B. This insulation system is believed to be too rigid for this application even if it is developed to its intended insulation capability (as a comparison, the elongations-at-break for Kapton[®], FEP and Upilex[®] are about 75%, 300%, and 30%, respectively).
3. The PFPI film has been successfully cast, slit and spliced into continuous tape, and tape-wrapped onto copper conductor using current manufacturing technology. Despite the drying obstacles, roughly 2000 feet of 20 AWG conductor wire were doubly wrapped with the AFR700B coated PFPI tape with a 52% overwrap and a nominal insulation thickness of 6 mil.

4. A more compatible web for casting of PFPI film or other advanced films must be identified to allow the initial drying of the as-cast film at higher temperatures.
5. More effective means to completely remove solvents or moisture from the solution-cast film for final drying at lower temperatures must be identified. One approach for PFPI film involves the use of co-solvent, with NMP in the solution casting. Similar approach may be necessary for applying an adhesive coating onto the cured film by either solution casting method or spray coating methods.

6.0 RECOMMENDATIONS FOR FURTHER WORK

TRW strongly believes that further work is necessary to yield polymeric dielectric film insulation materials truly superior to state-of-the art Kapton[®] film and film wrapped fluorocarbon materials. The specific key technical areas recommended for further development are as follows:

1. Exploratory work to modify molecular structure of PFPI by extending the mean molecular weight beyond that of 4-BDAF/PMDA formulation to improve its flexibility while retaining its high temperature dielectric properties and resistance to thermal oxidative environment.
2. Review of state-of-the-art and new high temperature polymeric materials must be conducted to identify potential films and sealant material candidates. In addition to the good electrical, thermal, chemical and mechanical properties required for wire insulation, these candidates must possess good toughness and must be easily processed into films.

7.0 REFERENCES

1. D. K. Kohli, "Development of polyimide Adhesive for 371°C (700°F) Structural Performance in Aerospace Bonding Applications - FM680 System," 37th International SAMPE Symposium, Pages 430-439. March 9-12, 1992.
2. B. Rice, "AFR700B - An Overview", HTEMP Review, NASA Conference Publication 1993.
3. R. J. Jones and W.F. Wright, "High Temperature Polymer Dielectric Film Insulation", WL-TR-91-2105, February 1992.
4. R. Solomon et al., "New Insulation Construction for Aerospace Wiring Applications," F33615-89-C-5605, 1992.

APPENDIX

REXHAM CUSTOM

PO Box 368
Matthews NC 28106-7003
Fax 704 845 4333
Telephone 704 847 9171

PD-95-081

July 6, 1995

Dr. Wing C. Wong
TRW Space & Electronic Group
01/2236
One Space Park
Redondo Beach, CA 90278

Dear Dr. Wong:

Enclosed is the summary for the PFPI coating trials and the TGA measurements of the products Rexam conducted for TRW on June 26-27, 1995. If you have any questions regarding the summary and TGA's, please do not hesitate to contact me. I enjoyed talking with you on the phone and look forward to working with you again.

Sincerely,



Quan Song, Ph.D.
New Product Development Group

QS/lb

Enclosure

cc: R. Fields - Rexam



TRW TRIAL SUMMARY

7/5/95

On June 26-27, 1995, Rexam at Mathews conducted polyimide (PFPI) coating trials for TRW on the Pilot Coater. PFPI polyimide film was coated on 5 mil polyester (PET). Before the trials, TRW provided conditions for both film casting and drying. Rexam performed some experiments in the laboratory to test these conditions. We found the viscosity of the PFPI solution suggested by TRW (~ 1000 cP) allowed the solution to flow on the substrate during the drying process, making it hard to achieve films with uniform thickness. We also tried various drying conditions using an oven and found drying at temperatures > 250°F soon after casting did not blister the coating. On the basis of these experiments, film casting and drying conditions proposed for the trials were slightly modified (with the permission from TRW) from the one suggested by TRW.

The PFPI film casting and first pass drying on 6/26/95 were successful. The conditions used were:

PFPI% solid:	14.8
Viscosity	10,500 Centipoise
Pump Speed	20 RPM
Drying Temperatures	zone 1: 250 °F, zone 2: 300°F, zone 3 & 4: 350°F
Oven Air Flow	zone 1: 712, zone 2: 789, zone 3: 1060, zone 4: 1993

With these casting and drying conditions, smooth PFPI films with minimum defects were obtained. After the first pass drying, the film was easily separated from the PET substrate and was strong enough to stand by itself. Film thickness was measured to be 1.2 mils. TGA results indicated the film contained ~20 % solvent after the first pass. With the above conditions, Rexam coated three rolls of PFPI films with roll numbers 1001, 1002, and 1003 at 1000, 1500 and 800 feet, respectively. TGA tests for these rolls were

Roll 1002	20.7%
Roll 1002	22.4%
Roll 1003	20.0%

The objective of June 27 was to dry the films coated during the previous day. The first try was to separate the PFPI film from the PET substrate and dry at 350°F through the four temperature zones. Roll 1003 was tried first at 10'/min. The film seemed to become more brittle after the second pass and it broke when it came out of the oven. The coating after the second pass was checked with TGA and showed ~13% NMP solvent. In addition, the film shrank in both width and thickness, from 14" to 10.5" and 1.2 mil to 0.9 mils, respectively. We had three tries and the films broke every time before the dried films were wound up.

We believe the film after the second pass became brittle and it was hard to maintain uniform tension on the Pilot Coater. So we decided to dry the films with the PET substrate on. The oven temperatures were set at 350°F for all the four zones and the speeds of 5'/min and

10'/min were tried. With the speed at 10'/min the PFPI/PET film curled substantially after the second drying cycle, but with much difficulty we were able to wind a roll. With speed at 5'/min the film curled so badly we could not wind a roll. TGA's were checked for films dried at both speeds and showed 14.9% and 13.7% of NMP for 10'/min and 5'/min, respectively. Because of the small differences in solvent concentrations for the two drying conditions, we decided to dry the film at 10'/min. We started with Roll 1002 and generated Roll 2001. During the drying process one of the Pilot Coater operators had to sit at the exit of the oven, where there are no guard rails, uncurling the film, and two other helped uncurl the film at the winders. At about 300' (Roll 2001) the Pilot machine stopped for an unknown reason. We felt it was unsafe to operate in this way and we did not have a workable machine process.

After discussing this with Bob Jones, we decided to try to dry separated PFPI film again. In order to reduce the tension on the dried PFPI film during the wind-up, a portable rewind was used. We used Roll 1003 for these tries. Unfortunately, all three tries failed and the film broke before it could be wound up.

After meeting with Bob, we decided to increase the drying temperatures from 350°F to 400 °F, again for separated PFPI films. We tried three times and the films broke, with each time at a different place. Since each of these tries consumed a substantial length of coated films we worried about using up the PFPI film without producing any desirable dried product. After talking with Bob Jones, we were instructed to try one more time with Roll 1002 and stop if it failed. We tried and it broke again. As instructed, we wrapped all the film in nitrogen purged bags and stored them in our cool room.

Rexam shipped five rolls (four boxes) of PFPI films packaged with dry ice to TRW on 6/29. These rolls are:

Roll 1001	first pass (coating only)	~450'
Roll 1002	first pass (coating only)	~450'
Roll 1003	first pass (coating only)	~100'
Roll 2001	first & second pass (coating and drying w/ PET)	~320'
Testing Roll		

In the same shipment was the unused AF-R-700B solution which was packaged with dry ice.

Based on our experience, it appears the PFPI film is plasticized by the NMP and become very brittle when dried to less than 15% NMP. With 15% NMP, the film is very tough, but it embrittle when dried. Bob Jones suggested the molecular weight of the PFPI degraded during storage and this caused the embrittlement. Rexam will measure the molecular weight of the polymer over a month storage at cool room using GPC. This information will be sent to Bob Jones when available.

TGA ANALYSIS RESULTS

Sample	Drying Conditions	Percent NMP at 400 °C
Roll 1001	250 °F, 300 °F, 350 °F, 350 °F at 10'/min.	20.7%
Roll 1002	250 °F, 300 °F, 350 °F, 350 °F at 10'/min.	22.4%
Roll 1003	250 °F, 300 °F, 350 °F, 350 °F at 10'/min.	20.0%
Second Pass A Roll 1003	Drying with PET 350 °F, 350 °F, 350 °F, 350 °F at 10'/min.	15.7%
Second Pass B Roll 1003	Drying with PET 350 °F, 350 °F, 350 °F, 350 °F at 5'/min.	13.9%
Second Pass C Roll 1001	Drying off PET 350 °F, 350 °F, 350 °F, 350 °F at 10'/min.	14.1%
Second Pass D Roll 1001	Drying off PET 400 °F, 400 °F, 400 °F, 400 °F at 10'/min.	7.9%
Second Pass E	Drying off PET Stay in the 400 °F oven for ~30 min.	2.8%

Curve 1: TGA

File info: trw000 Mon Jun 26 14:17:39 1995

Sample Weight: 2.325 mg

TAM Check out #1 (Pilot Coater)

TAM Check out #1 (Pilot Coater)

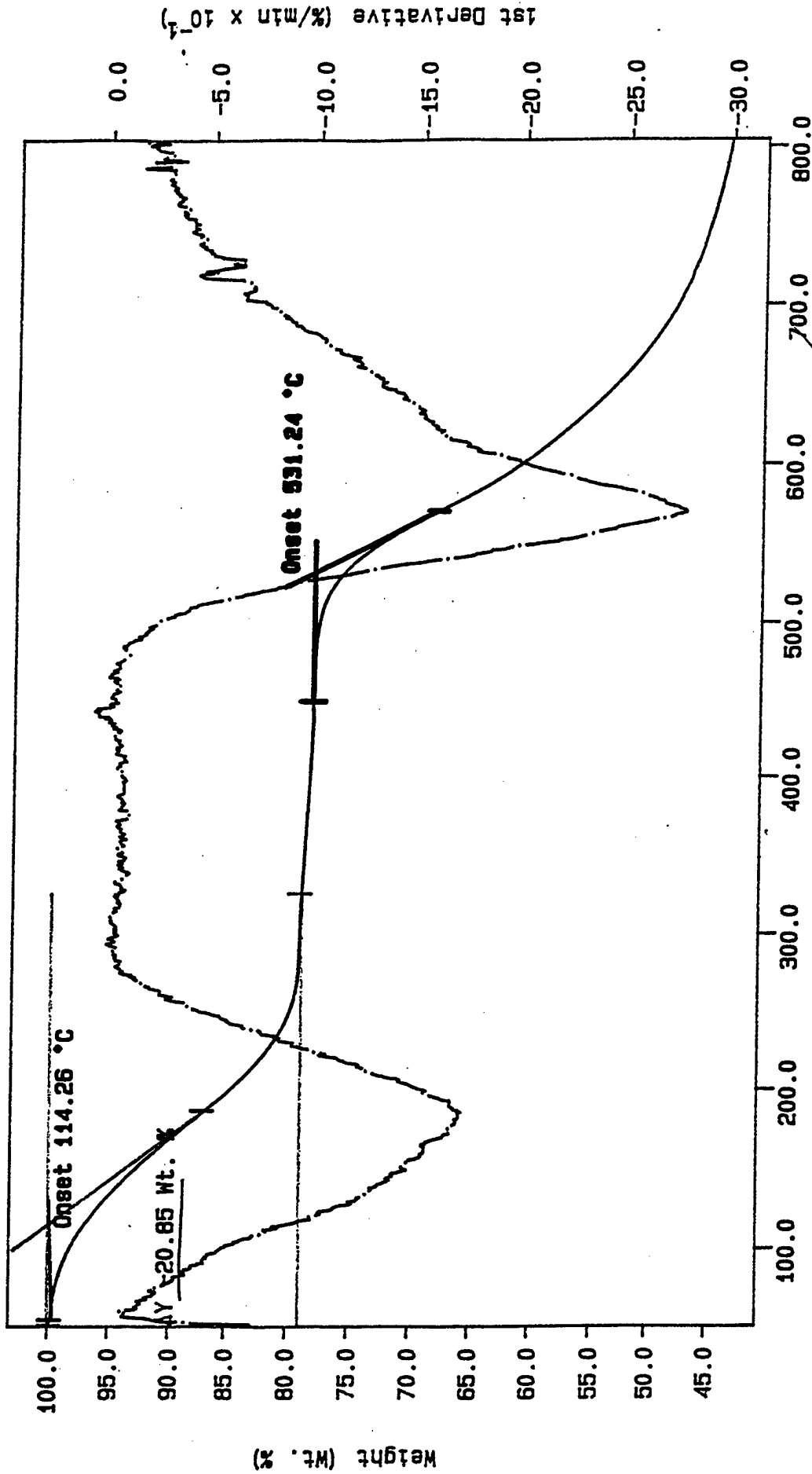

T K Lanning
 Rexham Analytical Services
 Rexham Custom, Matthews, N.C.
 Mon Jun 26 14:25:27 1995

TEMP: 50.0 & 800.0 & TIME: 0.0 min RATE: 10.0 c/min

Curve 1: TGA
File info: trw002 Mon Jun 26 15:42:30 1995
Sample Weight: 2.157 mg
TRW Check out #1 (Pilot Coater)

TRW Check out #1 (Pilot Coater)

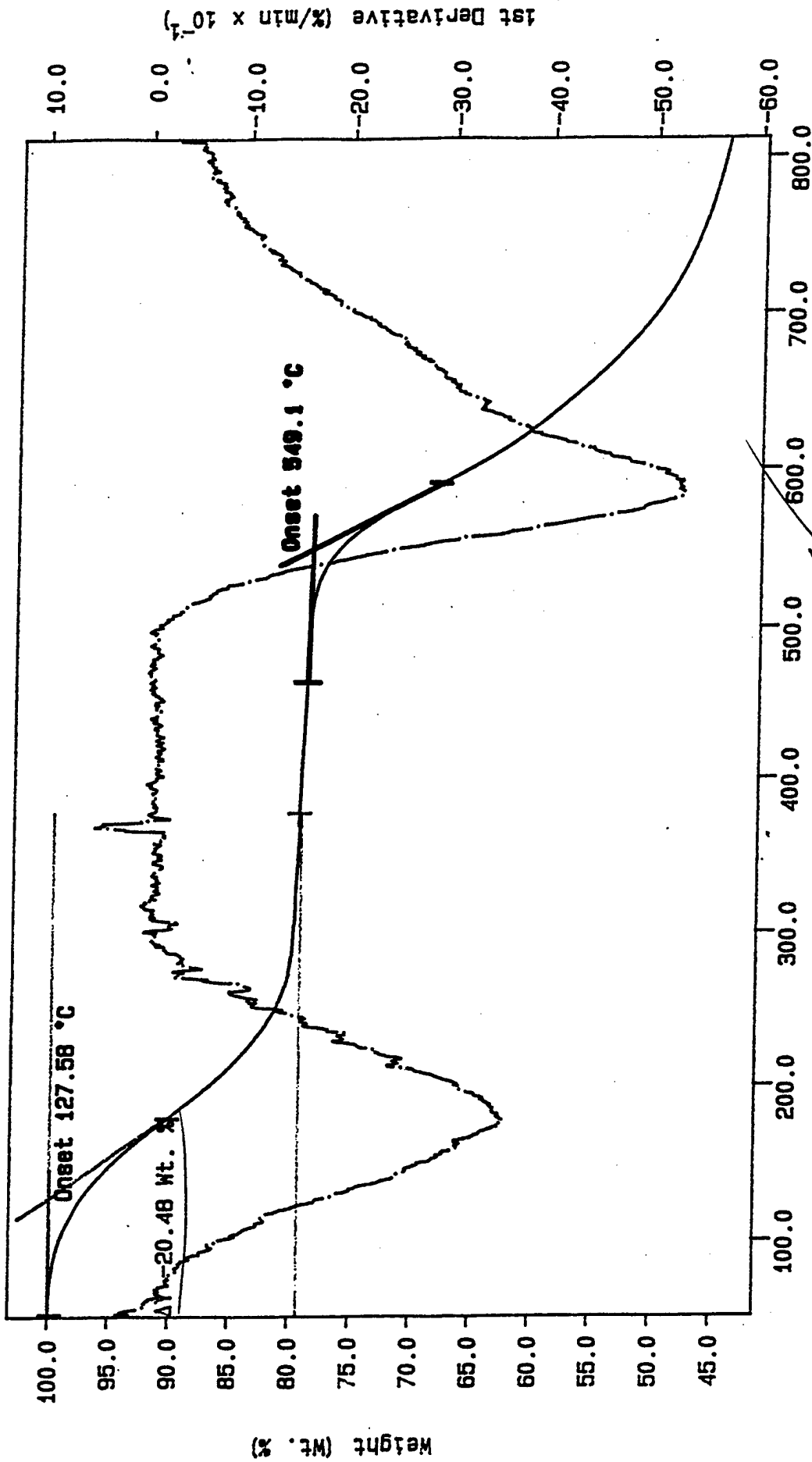

W K Lanning
Hexham Analytical Services
Hexham Custom, Matthews, N.C.
Mon Jun 26 15:44:17 1995

250, 300, 350 & 400F @ 10ft/minute
TEMP: 50.0 C TIME: 0.0 min RATE: 20.0 C/min

Curve 1: TGA

File info: TRM005 Tue Jun 27 01: 40: 18 1995

Sample Weight: 2.903 mg

TRM ROLL 1002 (PILOT COATER)

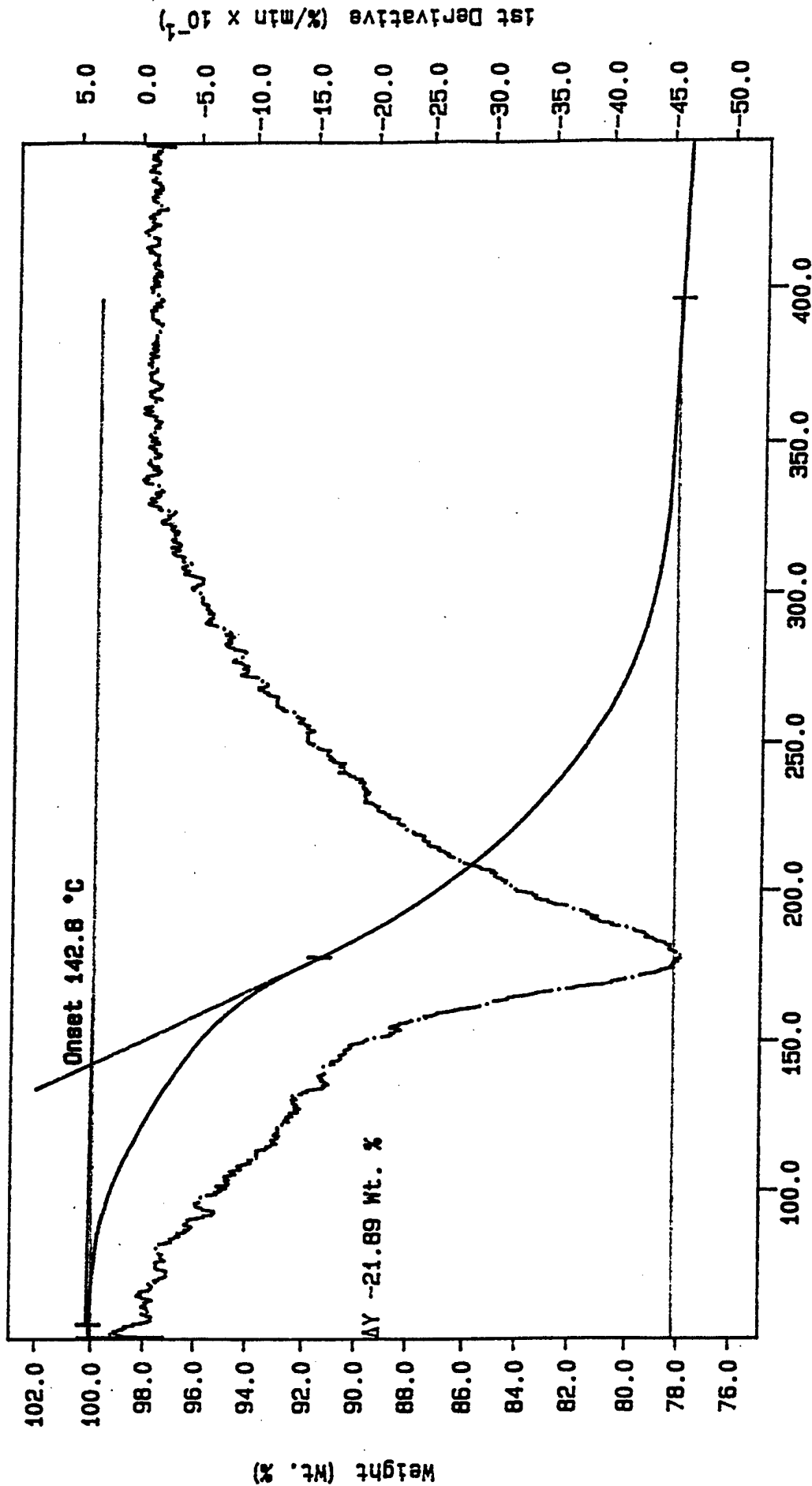

250, 300, 350, 350 AT 10FPM

TEMP1: 50.0 C TIME1: 0.0 min RATE1: 20.0 C/min

Temperature (°C)

C E PIERCE
Rexham Analytical Services
Rexham Custom, Matthews, N.C.
Tue Jun 27 01: 58: 22 1995

Curve 1: T6A

File info: TRW004 Tue Jun 27 00: 42: 15 1995

Sample Weight: 3.053 mg

TRW ROLL 1002 (PILOT COATER)

TRW ROLL 1002 (PILOT COATER)

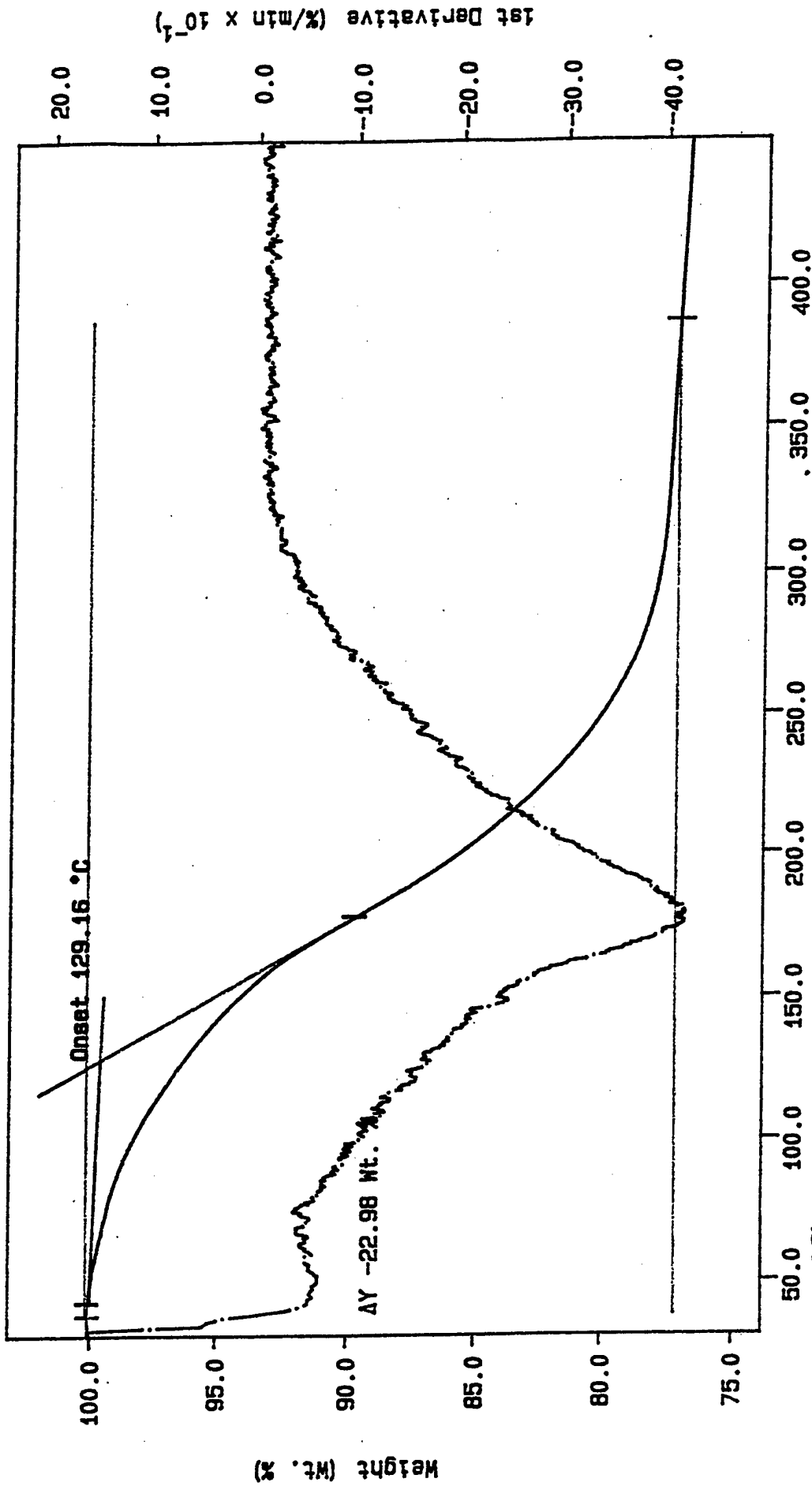

TEMP1: 50.0 & TIME1: 0.0 min RATE1: 20.0 C/min
TEMP2: 450.0 & TIME2: 0.0 min RATE2: 20.0 C/min
350
T-K Tanning
Rexham Analytical Services
Rexham Custom, Matthews, N.C.
Tue Jun 27 05: 17: 04 1995

Curve 1: TGA
File info: trw009 Tue Jun 27 11:53:13 1995
Sample Weight: 0.683 mg
TRW Roll 1003 (pilot Coater)

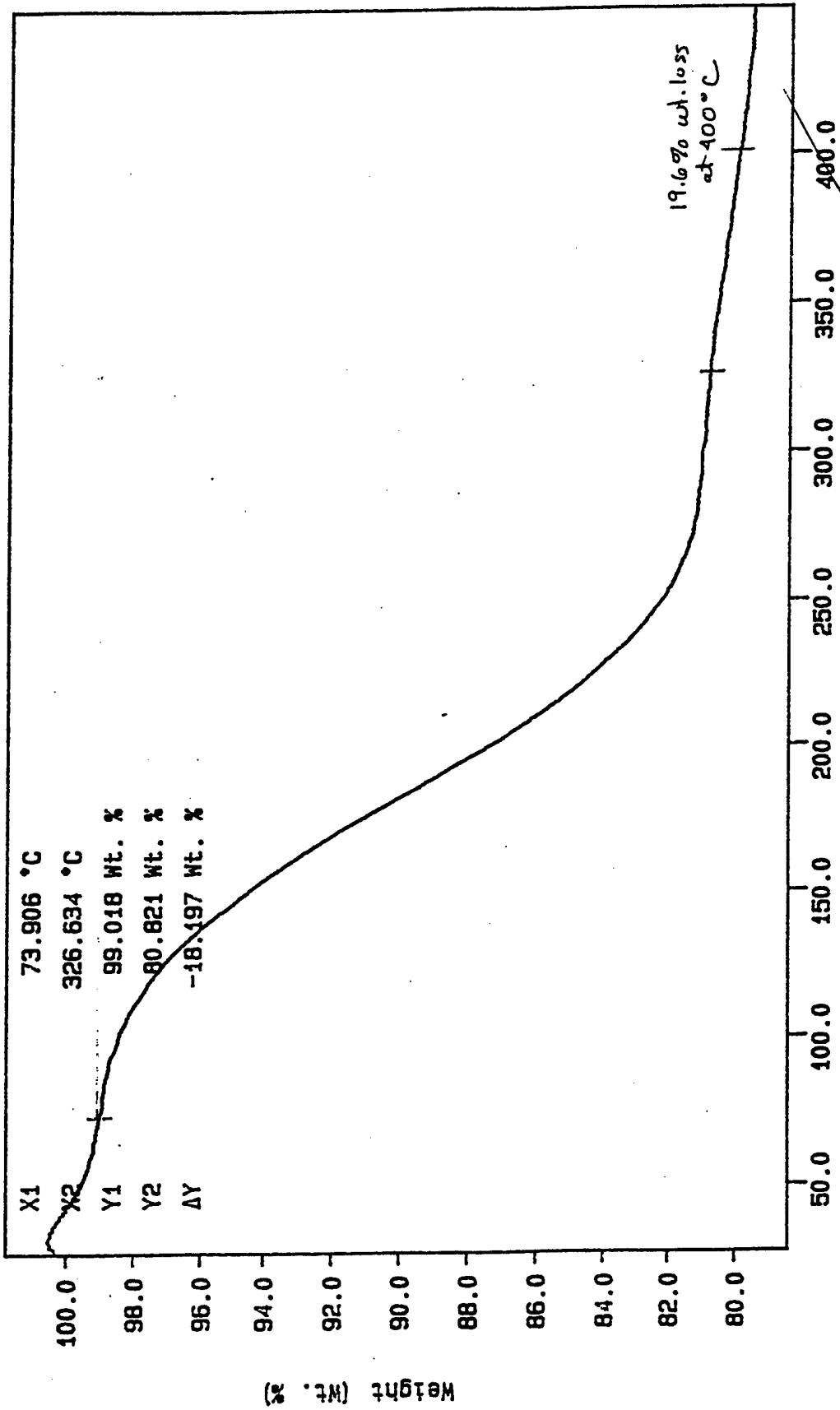

end of roll 10 ft/minute
TEMP: 40.0 C TIME: 0.0 min RATE: 20.0 C/min
T K Lanning
Hexham Analytical Services
Hexham Custom, Matthews, N.C.
Tue Jun 27 15: 18: 41 1995

Curve 1: TGA
File info: trw003 Tue Jun 27 08:34:13 1995
Sample Weight: 2.222 mg
TAM 1003 (pilot coater)

TAM 1003 (pilot coater)

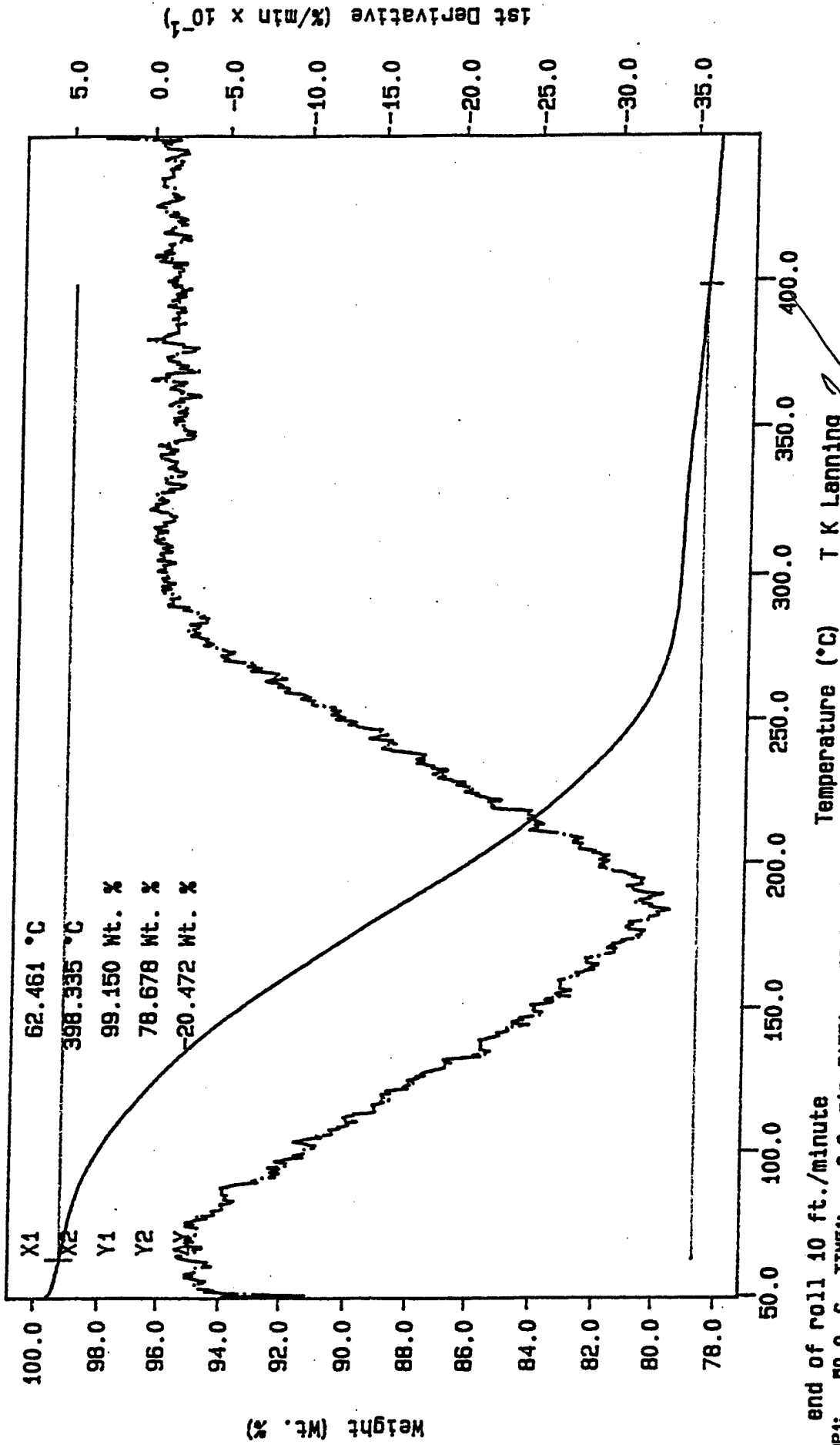

T K Lanning
Rexham Analytical Services
Rexham Custom, Matthews, N.C.
Tue Jun 27 08:37:37 1995

Curve 1: TGA
File info: trw011 Tue Jun 27 13:14:04 1995
Sample Weight: 1.392 mg
TAW drying conditiond (pilot coater)

10 fpr on PET
350°F

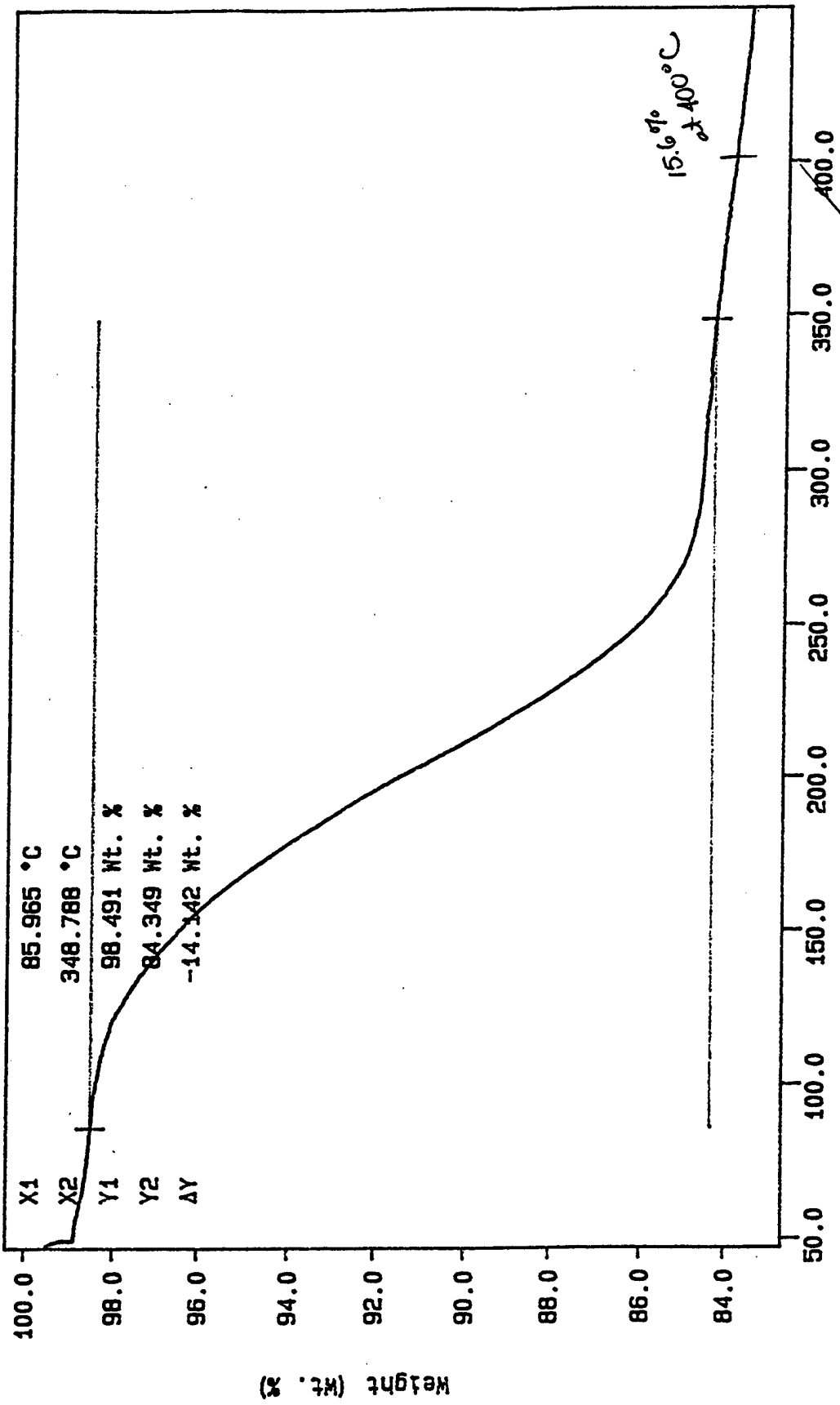

10 feet/minute
TEMP: 48.8 C TIMES: 0.0 min RATE: 20.0 g/min
Temperature (°C)
T K Lanning
Rexham Analytical Services
Rexham Custom, Matthews, N.C.
Tue Jun 27 14:56:54 1995

10 fm - on PET.
350 gf

Curve 1: TGA
File Info: trw008 Tue Jun 27 11:05:07 1995
Sample Weight: 0.637 mg
TRW film drying condition (pilot coater)

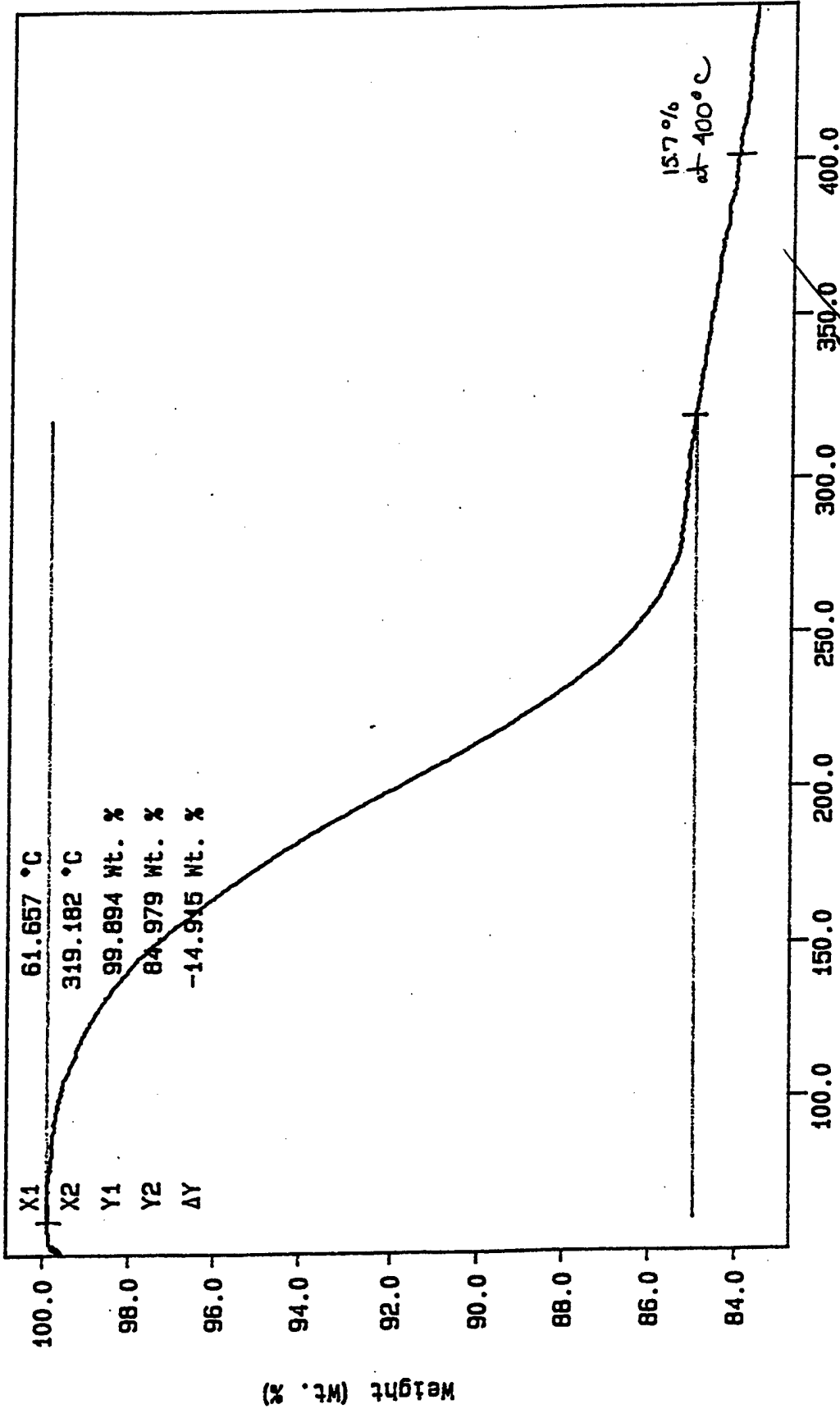

10 feet/minute
TEMP: 40.0 C
TIME: 400.0 C

0.0 min RATE: 20.0 C/min

T K Lanning
Rexham Analytical Services
Rexham Custom, Matthews, N.C.
Tue Jun 27 11:06:21 1995

Curve 1: TGA

File info: trw010 Tue Jun 27 12:27:09 1995

Sample Weight: 1.289 mg

TRW drying conditions (pilot coater)

350 °F 5 gm on PET

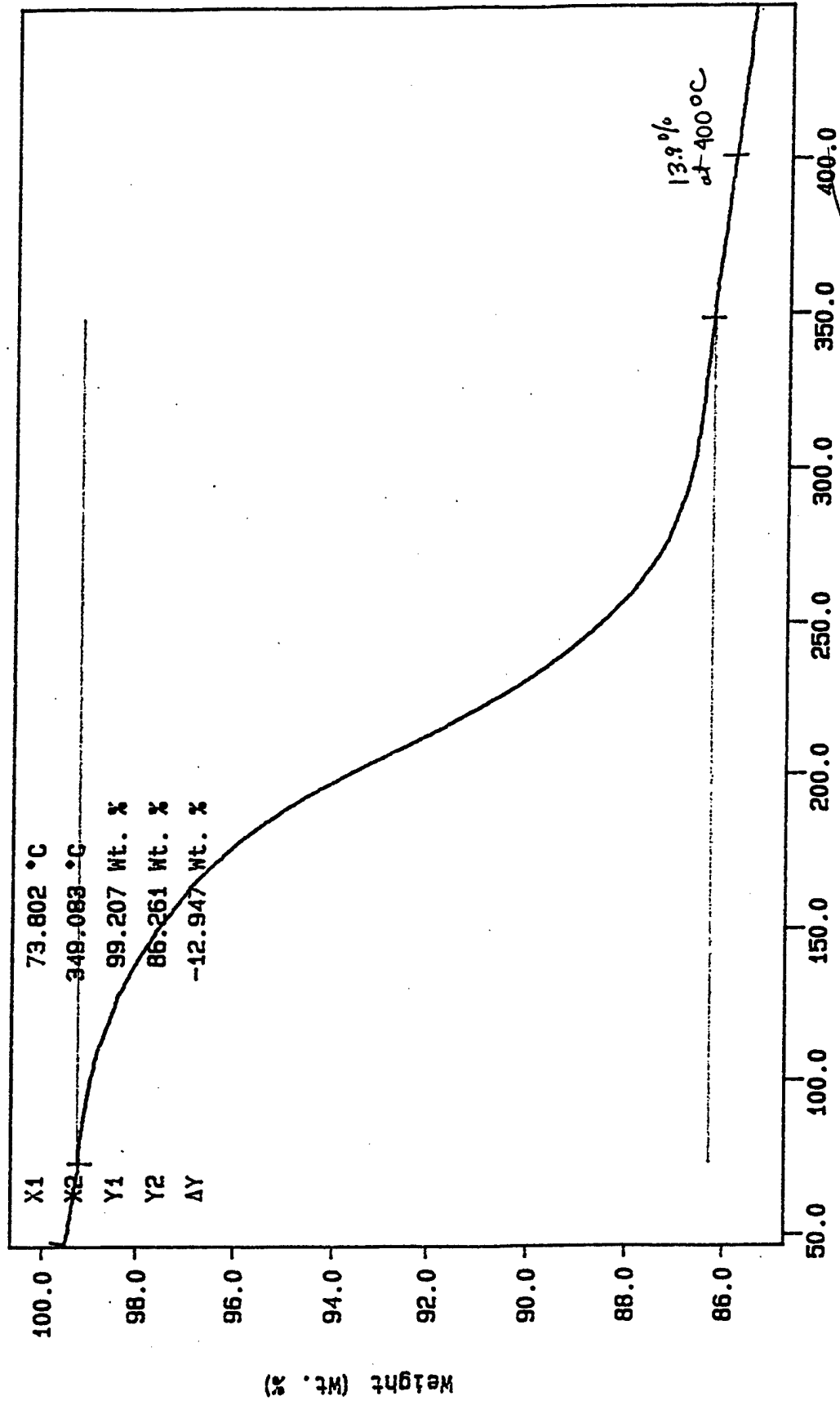

13.9% at 400 °C

5 feet/minute
 TEMP: 40.0 °C TIME: 0.0 min RATE: 20.0 c/min
 T K Lanning
 Rexham Analytical Services
 Rexham Custom, Matthews, N.C.
 Tue Jun 27 15:07:50 1995

350°F 5fpr on DET.

Curve 1: TGA
File info: trw006 Tue Jun 27 09:45:45 1995
Sample Weight: 1.352 mg
TIN drying conditions (pilot coater)

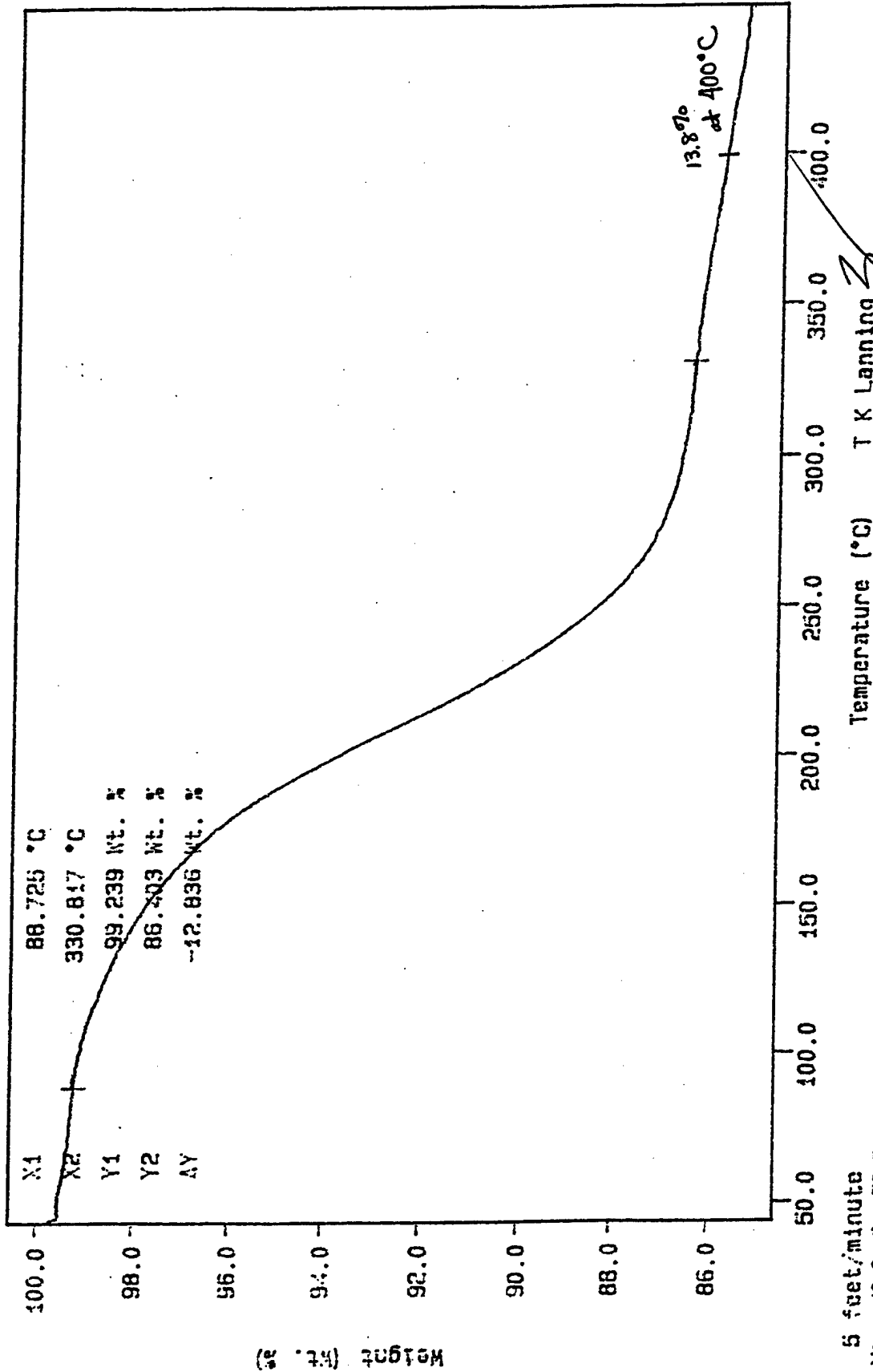

5 feet/minute
TEMP: 40.0 °C
TIME: 130.0 s
MIN RATE: 0.0 g/min
MAX RATE: 20.0 g/min

Temperature (°C)

T K Lanning
Rexham Analytical Services
Rexham Custom, Matthews, N.C.
Tue Jun 27 15:25:18 1995

Curve 1: TGA
File info: trw012 Tue Jun 27 14:26:21 1995
Sample Weight: 0.692 mg
TRW off substrate (pilot coater) 1st dry w/o PET.

10 tgrna

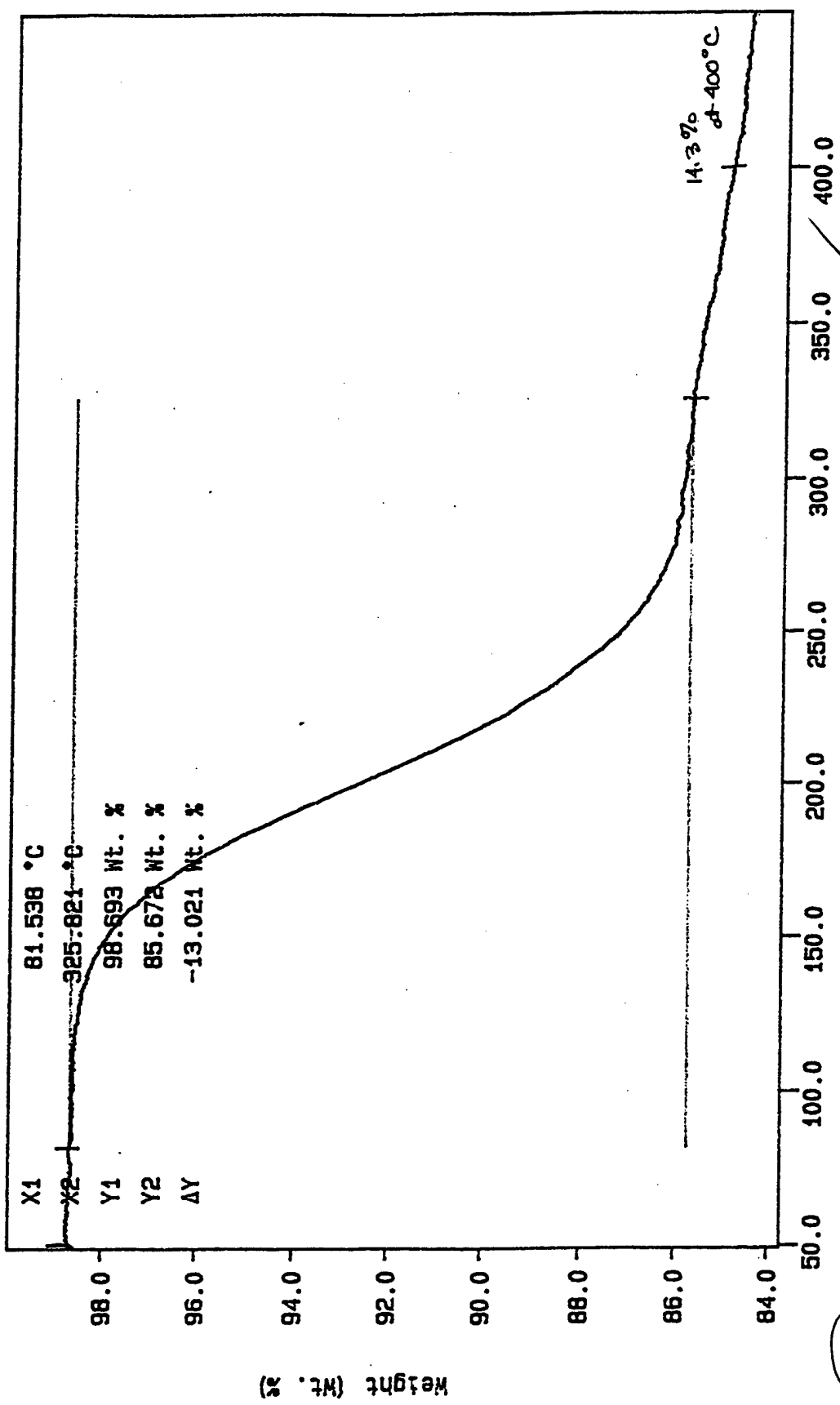

350 F drying
TEMP1: 40.0 C TIME1:
TEMP2: 400.0 C TIME2:
0.0 min RATE1: 20.0 C/min
Temperature (°C)
T K Lanning
Rexham Analytical Services
Rexham Custom, Matthews, N.C.
Tue Jun 27 14:51:23 1995

Curve 1: TGA
File info: trw007 Tue Jun 27 10:19:29 1995
Sample Weight: 0.691 mg
TGA film removed from substrate New 28 substrate - 1st dry w/o PST
10 + pm -

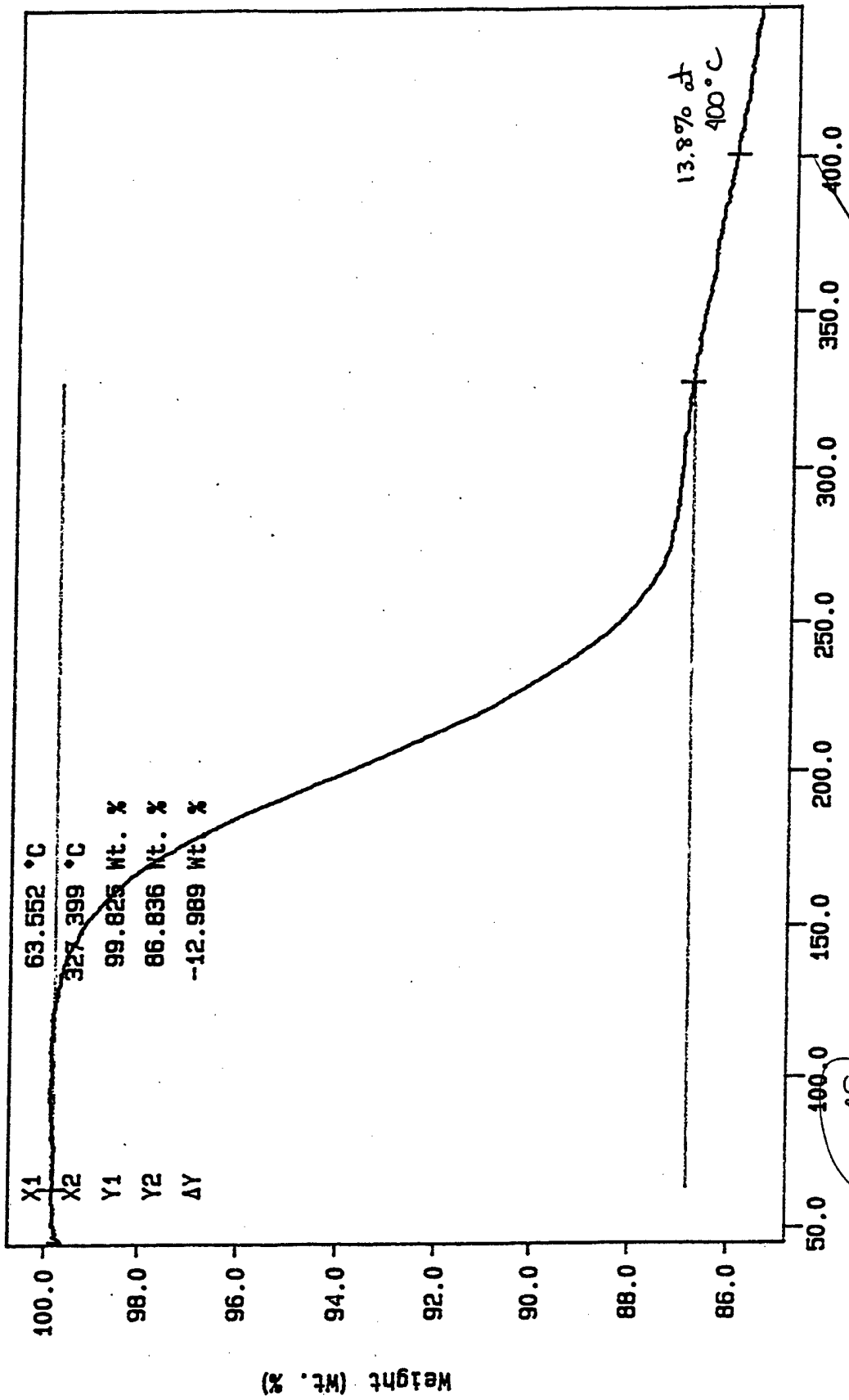

pilot coater
TEMP: 48.8 C TIMES: 0.0 min RATE: 20.0 C/min
350°F
T K Lanning
Rexham Analytical Services
Rexham Custom, Matthews, N.C.
Tue Jun 27 10:20:39 1995

Curve 1: TGA
File info: TRW400 Tue Jun 27 18:09:07 1995
Sample Weight: 2.248 mg
TRW OFF Substrate (Pilot Ctr)

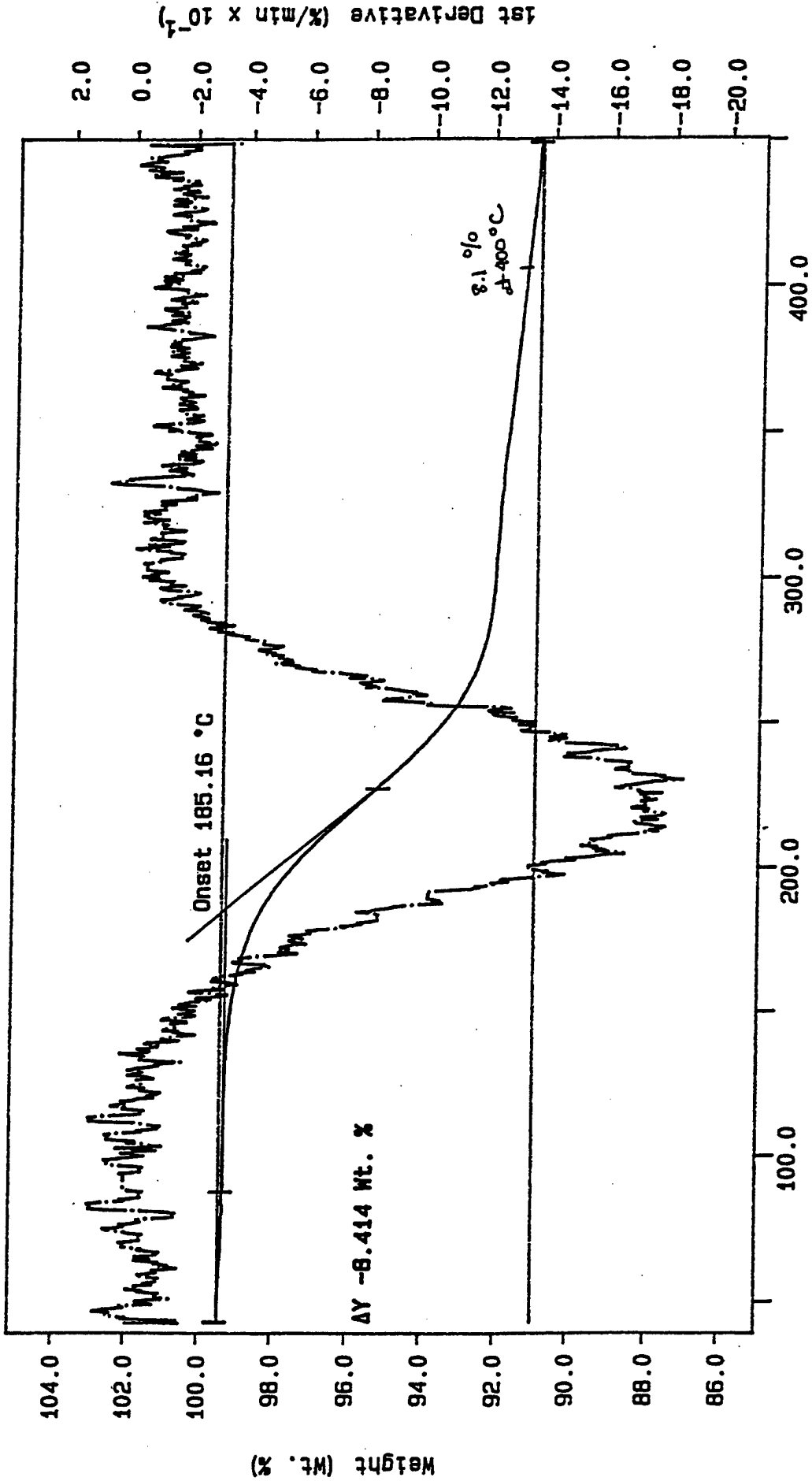

400 Degree Drying
TEMP: 40.0 C TIME: 0.0 min RATE: 20.0 c/min
V Brinson
Rexham Analytical Services
Rexham Custom: Matthews, N.C.
Tue Jun 27 22:19:56 1995

Second Pass D
Roll 1001

Curve 1: TGA
File info: TRW401 Tue Jun 27 20:19:42 1995
Sample Weight: 1.892 mg
TRW OFF Substrate (Pilot Ctr)

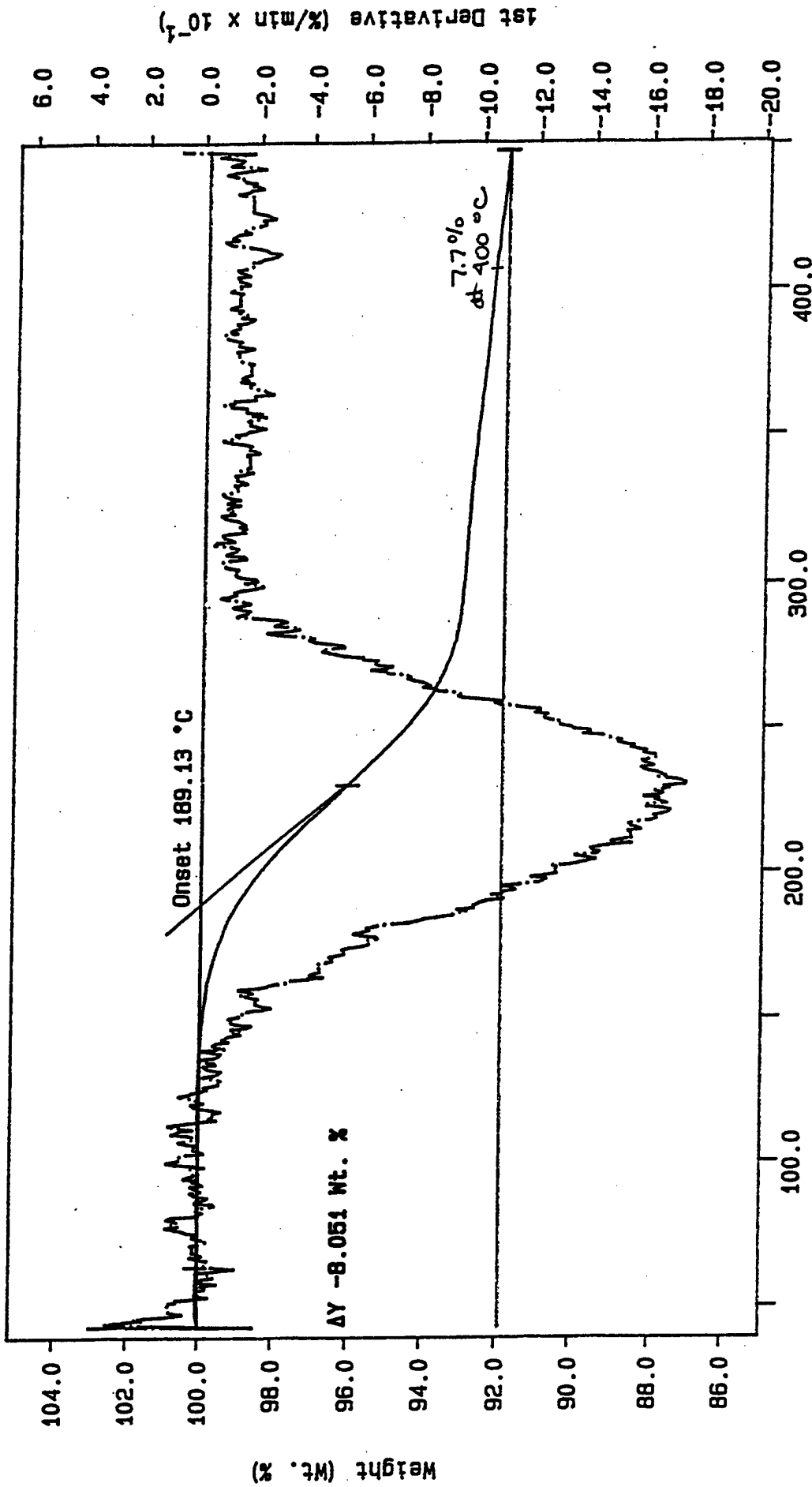

400 Degree F, 10 Ft per Min Drying
TEMP: 400.0 C TIME: 0.0 min RATE: 20.0 c/min
V Brinson
Rexham Analytical Services
Rexham Custom, Matthews, N.C.
Tue Jun 27 22:05:00 1995

Curve 1: TGA

File info: TRW403 Tue Jun 27 19:32:59 1995

Sample Weight: 1.314 mg

TRW OVEN SAMPLE (Pilot Ctr)

TRW OVEN SAMPLE (Pilot Ctr)

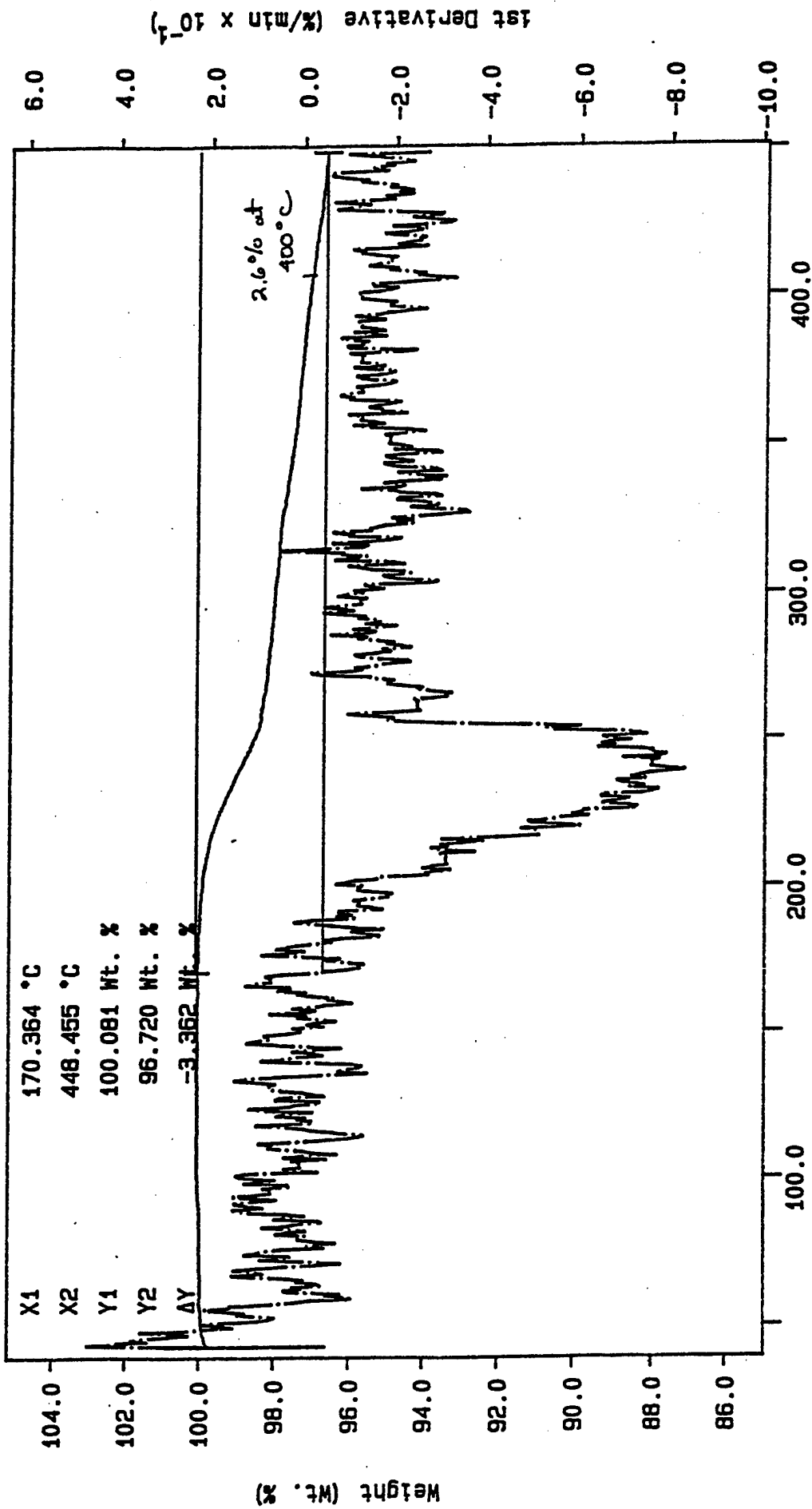

V Brinson
Rexham Analytical Services
Rexham Custom, Matthews, N.C.
Tue Jun 27 22:51:18 1995

Temperature (°C)

Sat in 400F Oven (Brittle)

TEMP1: 40.0 °C TIME1: 0.0 min RATE1: 20.0 °C/min

Curve 1: TGA
File info: TRM404 Tue Jun 27 21:02:32 1995
Sample Weight: 1.060 mg
TRW OVEN SAMPLE (Pilot Ctr)

TRW OVEN SAMPLE (Pilot Ctr)

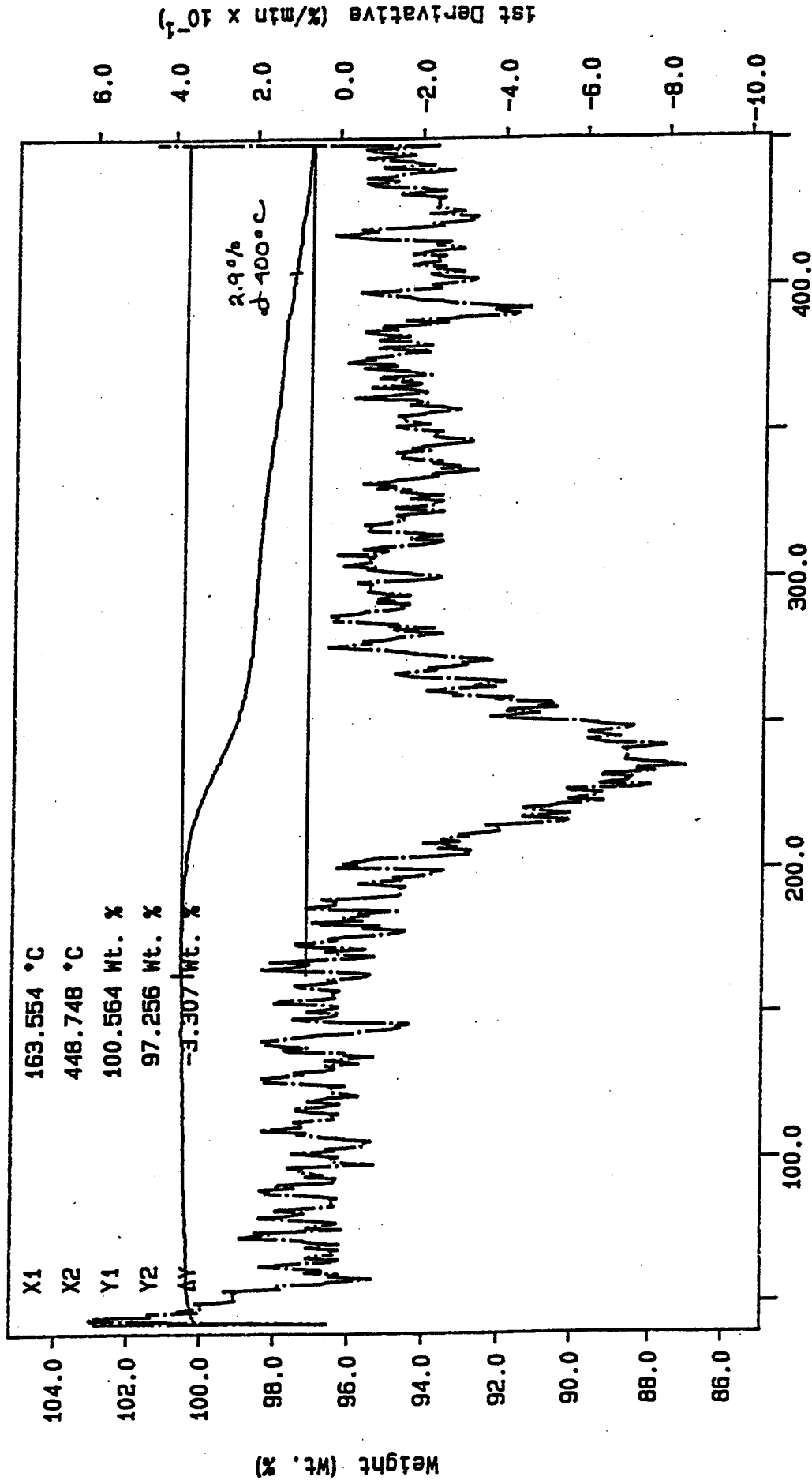

Sat in 400F Oven (Brittle)
TEMP: 48.8 °C TIME: 0.0 min RATE: 20.0 °C/min
V Brinson
Rexham Analytical Services
Rexham Custom, Matthews, N.C.
Tue Jun 27 22:37:48 1995