

The Pennsylvania State University
The Graduate School
Department of Electrical Engineering

**PEAK SHAVING AND ALTERNATIVE POWER:
A Question of Economy, Quality of Life and Quality of Electricity**

A Masters Paper in
Electrical Engineering
By
David Matthew Smith

Submitted in Partial Fulfillment
of the Requirements
for the Degree of
Master of Science

July 1999

DISTRIBUTION STATEMENT A
Approved for Public Release
Distribution Unlimited
DTIC QUALITY INSPECTED 4

19990827 099

We approve the Masters Paper of David M. Smith.

Date of Signature

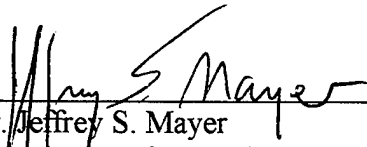

Dr. Jeffrey S. Mayer
Associate Professor of Electrical Engineering
Masters Paper Advisor

7-15-99

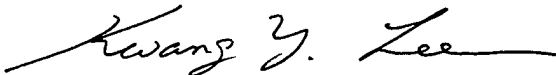

Dr. Kwang Y. Lee
Professor of Electrical Engineering

7-15-99

ABSTRACT

The Navy will need to upgrade the utility infrastructure of its installations in the coming years. There are several factors that they will need to take into consideration, to include energy conservation, environmental and quality of life issues. Peak shaving and load shedding are good business decisions and could be conducted in a better way than they are currently being done.

Fuel cells offer a variety of options for co-generation and power management. A prudent use of the by-products of electric generation from a fuel cell could increase efficiency of the plant and provide cost savings to the user.

The objective of this paper is to look at the problem of being able to peak shave without penalizing the equipment and personnel on board ships that are in port. By understanding the technologies available in fuel cells, a proper choice and proposal can be made.

As Molten Carbonate Fuel Cells and Solid Oxide Fuel Cells become commercially available, the Navy needs to consider using them as power sources for the piers. The co-generation capabilities would be used to generate clean shore steam, one of the many pier services that the ships require.

TABLE OF CONTENTS

Abstract	iii
Table of Contents	iv
List of Figures	vi
List of Tables	vii
Acknowledgements	viii
Chapter 1: Introduction	1
1.1 Possible Technologies	3
1.2 The Problem Defined	4
1.3 Fuel Cell Benefits	7
1.4 Fuel Cell Evolution	10
1.5 Fuel Cells for the Department of Defense	11
Chapter 2: Fuel Cell Stacks and Reformers	13
2.1 Introduction	13
2.2 Fuel Cell Reactions	13
2.3 Fuel Cell Design Features	17
Chapter 3: Fuel Cell Power Plants	24
3.1 Introduction	24
3.2 Balance of Plant and Grid Configurations	24
3.3 Power Conditioning Sub-System	26
3.4 Fuel Handling Requirements	34
3.5 Heat Exchangers	35

Chapter 4: Proposed Solution	37
4.1 Introduction	37
4.2 Proposed Solution	37
4.3 Life-Cycle Costs	41
4.4 Economy Realized	42
Chapter 5: Conclusion	44
Appendix A	46
Appendix B	51
Bibliography	55

LIST OF FIGURES

- 1.1 Generation Efficiencies
- 1.2 Facility Types Using PAFC Plants
- 2.1 Evolving SOFC Cell Configurations
- 2.2 Schematic Representation of Westinghouse Tubular Solid Oxide Fuel Cell
- 3.1 Generic Fuel Cell Power Plant
- 3.2 Configuration for Fuel Cell Grid Connections
- 3.3 Three Phase Line Commutated Inverter
- 3.4 Line Notching Effect
- 3.5 Single Phase PWM (Single Leg Inverter)
- 3.6 Single Phase PWM Waveforms and the Harmonics
- 3.7 Three Phase PWM Waveforms and the Harmonic Spectrum
- 3.8 Block Diagram of a Controller for Static VAR Compensator
- 4.1 Brassboard and Fuel Cell Block Diagram
- 4.2 Break-Even Analysis of a 200kW PAFC

LIST OF TABLES

- 1 Emission Levels for Fuel Cells
- 2 PAFC 200kW Plant Statistics
- 3 U.S. Army Soldier Systems Center Natick
- 4 Overview of the Characteristics of Fuel Cells
- 5 Ship Power Requirements Pier-Side
- 6 Fuel Cell Performance Results Using Logistics Fuels

ACKNOWLEDGEMENTS

I would like to thank Ms. Teresa Issenhouer whose patience and explanation of how utilities for pier services operated was invaluable.

I would also like to thank EMCM(SW) Gregory Burt for correcting my memory and gathering Navy technical information for me. It is true, a Navy Chief is always training his officers.

A final thanks go to the Snipes of the Navy (shipboard engineering department). Without your hard work and dedication, we would never meet the mission.

CHAPTER 1

INTRODUCTION

With the reduction in the number of ships but no reduction in operational tempo, it becomes critical to provide the best service possible to the ships when they are pier-side. We need to ensure that the electrical, heating, water and sewage services do not add unnecessary burdens to the ship's crew.

Currently, as summers set in, Naval Stations are requested by the local utilities to shed load or peak shave to prevent voltage collapse of the entire grid and to prevent the Navy from paying higher rate charges during these periods. This is achieved by paralleling Ship Service Diesel Generators (SSDG) or Ship Service Gas Turbine Generators (SSGTG) temporarily and then removing either partly or entirely the ship's electrical load from the grid. This policy is bad for the equipment, for the environment and for the quality of life of the ship's engineers. The load that is maintained on the SSDG or SSGTG during this time is not enough for proper efficiency of fuel burn and is hard on both the prime mover and the generator. The combustion process that is occurring emits to the atmosphere NO_x , SO_x and CO_2 pollutants that are harmful to the environment. Most importantly, this policy causes members of the crew to be left monitoring the equipment and systems while their shipmates are going home to their families at the end of the normal workday. This problem is then further exacerbated when the ship runs pier side drills that require the Combat Suite to be up and operating. This causes additional

load on the grid which results in the local utility asking for the Navy to peak shave more often.

The objective of this paper is to outline the technologies that are available to allow the Navy to be a “good neighbor” to the local community and a good customer to the local utility companies by shedding some of the load while minimizing pollution. Moreover, a specific technology, namely fuel cells, is proposed as a system that is more efficient than the current system. The economy achieved would offset the capital investment and not be at the cost of the crewmember who spends enough time away from his or her family on a normal duty day or when the ship is at sea.

Fuel cells are identified as an excellent candidate for solving this problem and providing additional benefits to the Navy. The new developments in fuel cell technology would allow their placement near the piers and the use of their co-generation capabilities to supply other required pier-side services.

The remainder of this chapter is devoted to providing additional background on the problem of pier-side ship services and various technical options available, including fuel cells. We will then talk about the benefits, evolution of and the Department of Defense’s involvement in the development of fuel cells. In Chapter 2, terminology and technical details on the key components of a fuel cell power plant are presented. This is followed in Chapter 3 with a discussion of the auxiliary components of fuel cell power plants.

Chapter 4 provides a proposed solution to the problem presented and the economies realized, and Chapter 5 provides a conclusion to this research.

1.1 POSSIBLE TECHNOLOGIES

Electrical power generation technology has improved in several areas over the last few years. Advances in gas turbine waste heat recovery technology, fuel cells and renewable energy sources (solar, wind and tidal) make it prudent to consider upgrades to systems that currently use diesel or gas turbine generators.

Advancements in co-generation with the exhaust heat from gas turbine generators to supply steam turbine have increased efficiencies from 37 percent to 54 percent [1]. However, this has only been applied to generators in the 30 MW and larger range. Large capital investment costs and the inefficiencies of operating at partial load make an upgrade of gas turbines feasible only for a power utility or a corporation that plans on becoming totally self-sufficient. Therefore, we will not consider it for our proposal.

With renewable energy sources, particularly photovoltaics coupled to fuel cells or flywheels, have become extremely attractive for power generation. These hybrids have eliminated the large variance in the output power problem that was formerly an obstacle for some plants. This correction makes these units very reliable and efficient. The only limitation is the large amount of space required for these plants, which will limit where this application could be applied for a Naval installation.

Recent developments in the fuel cell manufacturing industry bring this particular option to the forefront for consideration. All types of fuel cells lend themselves to co-generation and could be used to generate steam or hot water necessary for pier services. This co-generation improves efficiency to a conservative 80 percent overall rating [2]. The footprint of the foundation for a fuel cell is relatively small, varying by manufacturer. For example, a 250 kW unit is as big as two tennis courts [2,3] and a 2-megawatt unit fits in one tennis court [3]. Additionally, they can be located next to any building because they are very quiet with a sound level of 68 dB at 10 feet which is “the sound level of a commercial office”[4].

Based on the reasons stated above, we will pursue the possibilities of correcting the problem of providing pier-side ship service power using fuel cells. Looking at what is commercially available now and what is about to come on-line, we will outline what could be a viable solution for the Department of the Navy in the years to come.

1.2 THE PROBLEM DEFINED

In order to know what the correct solution is, we need to fully understand the problem. We will talk in generic terms to cover all Naval bases with piers. However, the numbers used are ballpark figures collected for Naval Operations Base (NOB), Norfolk, Virginia, unless otherwise stated.

When a ship comes into homeport, it requires certain utility services because the engineering plant shuts down and all of the electrical and steam systems need to be supplied from Pier Services. The ships require steam for heating of hot water, cooking in the galley, for the scullery and laundry. Additionally, it uses steam for ship's climate control and steam jackets on boilers. The electrical load is greatly reduced from underway loads and needs to be supplied by shore activity for efficiency of manpower and fuel use.

Currently, most Naval installations purchase electricity from the local utility for the ships and generate their own steam using oil-fired boilers that produce boiler water/feed water quality steam. The present situation is for there to be a centrally located steam generation plant for the base. Studies are currently underway to determine if a nodal system of several smaller plants strategically located through out the base would be a better approach. If the decision is made to do this, then a co-generation plant may be the right solution.

At various times through the year, the local utilities request the Naval base to peak shave. The number of days throughout the year differs from location to location. Last year (1998), NOB Norfolk experienced 21 days of peak shaving. In order to meet the power utilities requests, the Naval station had the ships that were pier side remove load from the grid by switching to ships power using either a diesel generator or a gas turbine generator. The reasoning to reduce the load on the local grid is a business decision. The Navy has already spent the money for the fuel that is being consumed on the ship and it is

cheaper than paying the peak kilowatt per hour rates that the utility will be charging its customers during those periods. The ships are also used because the base emergency power generation systems do not lend themselves well to sectionalizing the base the way that ships can. When a ship does shift to its own power, a large section of the installation's load has been removed.

Cost avoidance is a good policy; however, the present strategy may not be the best approach. There are problems and inefficiencies with this policy. By looking at manpower, equipment and generation efficiency, there must be a better solution.

Each ship that participates in the peak shaving operation has at least two personnel on watch during this evolution. Depending on ship type and configuration, at least one of these personnel will be in an engineering space that will have temperatures of at least 90° F up to 120° F and sound levels greater than 140 dB. If our proposed solution could reduce this to one or two personnel per naval installation versus the twenty or more for ten ships, we have obtained economy in manpower.

The generators used for this evolution are designed and rated to handle combat loads. When a ship is pier side, unless conducting drills, the electrical load on these generators is less than 60 percent. This low load will cause pitting of the slip rings from low average current densities and failure of the brushes to develop the protective film required to prevent such pitting [5]. Additionally, diesel generators operating at less than 60 percent load causes the engine to carbon up and the lube oil to be diluted.

“Combustion at low or no load is incomplete and may cause heavy carbon deposits which will foul valves, valve stems, intake and exhaust ports and piston rings as well as exhaust system”[6].

Because these generators are being operated at partial load, they are not running at their optimum efficiency. Even if they were operating at peak efficiency, the amount of pollutants produced is cause for concern. Local authorities are establishing more stringent emission levels for NO_x , CO_2 and SO_x . This has occurred throughout California and Massachusetts and will probably occur wherever there are naval installations. The Navy will have to comply with these regulations and the time to consider solutions and take corrective action is now [7].

Additionally, the business decision to produce their own electricity cheaper than the rate at which the local utility charges can be furthered by using a generation process with efficiencies greater than diesel and gas turbine generation can provide.

1.3 FUEL CELL BENEFITS

The realization that we need to be better caretakers of our earth means that we need to find cleaner and more efficient uses of our diminishing fossil fuel energy sources.

Conventional coal plants operate at 33 to 35 percent efficiency [8]. Diesel generators operate at approximately 30 percent peak efficiency, while gas turbines operate at

approximately 37 percent efficiency [1]. The fuel cell operates at 55 percent efficiency as a power generator, which means more kilowatts of power for the same gallon or cubic meter of fuel. This efficiency can climb to 85 percent when used as a waste heat co-generation unit [8]. A comparison to include the co-generation efficiencies is shown in Fig. 1.1 below.

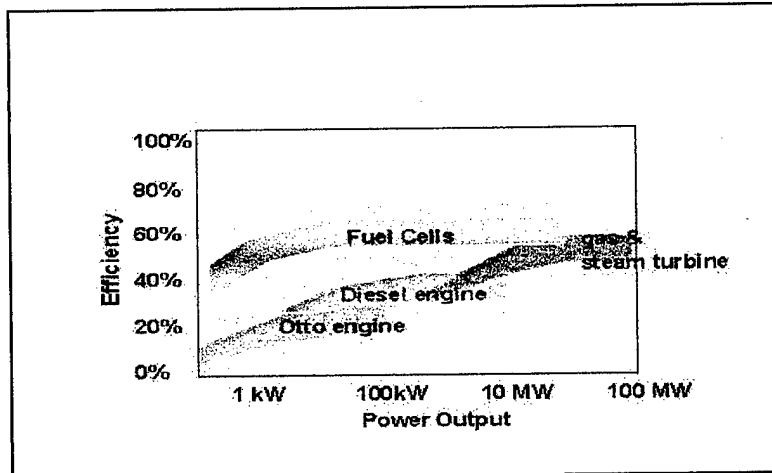

Figure 1.1 Generation Efficiencies [9]

The green house gasses (SO_2 , NO_x) and hydrocarbons produced by fuel cells are significantly less than the conventional means mentioned above and are less than one tenth of United States standards [4,10]. Additionally, it has significant reductions in CO_2 emissions. In fact, it can capture the CO_2 emissions and pipeline them to a commercial processor with some modifications to the plant [11]. These factors are important because they will keep the utility in compliance with ever increasingly stringent environmental air quality regulations.

Table 1 [7,12,13]			
Emission	PAFC	MCFC	SOFC
NOx	0.045	0.5	< 0.1
CO	1.4	(b)	(b)
SOx	(a)	(a)	(a)
(a) Emission levels were either negligible or lower than detectable			
(b) Comparable to other fuel cells but output level dependent on fuel cell loading.			
* Values ppmv			

The efficiency factor for fuel cells becomes even more significant when one considers that unlike the above-mentioned alternatives, it is as efficient at 25 percent load as it is at full load [14]. This is a rather critical factor when applying it to our particular situation and will be discussed later.

The fuel cell can act in different power feeding configurations. If paralleled with the main power of a facility, it can respond to surges and peak power demands. Specifically, because of its fast ramping capability, it can act as an un-interruptable power supply and/or emergency generator. A 40 kW fuel cell produced by International Fuel Cell can go from idle to full power in approximately 30 milliseconds [4]. It can also be a sole source power supply for a facility and depending upon local utility rates for fuel versus kilowatt-hours, costs can be significantly reduced.

The quality of the power produced by fuel cells is superior to normal utility power. The increase in the use of computers, electronic control systems and telecommunications equipment demands sources of electricity that are noise free. Highly reliable fuel cells provide just such requirements [7]. Their ability to act as supplemental systems to the main power, coupled with their fast ramping capability eliminates the requirement for high-cost un-interruptable power supplies.

The need for additional electric utility infrastructure can be eliminated by fuel cells. The production models are modular and can be placed directly next to the load because of their low emission and noise levels. The maintenance requirements are minimal either

annually or semi-annually, and consist of replacement of filter cartridges or adding of chemicals. These functions can be conducted by personnel that would need to receive only minimal training [4].

The co-generation possibilities for fuel cells are larger than one might think. The ability to retrofit buildings with fuel cells and either adapt present systems or replace the outdated ones with new upgrades are exciting. Waste heat of the fuel cell can be used for making steam or hot water where those applications are needed. The new air conditioning units that use absorption refrigeration using fuel cell waste heat offer energy and cost savings to the consumer. The implementation of these waste heat users can improve fuel cell efficiency to 85 percent [15].

1.4 FUEL CELL EVOLUTION

The concept of a fuel cell is not new. Sir William Grove invented the first fuel cell in 1839 [7]. However, because there was an abundance of cheaper generation processes to meet then-current demands, it was not developed any further. The space race was responsible for the resurgence of interest in this area. When facing long periods of darkness or “night” (14 earth days) on the moon, the need for a regenerative power, rather than batteries, became necessary [16]. This led to the development of the Phosphoric Acid Fuel Cell (PAFC).

With the energy crisis and increasing costs of fossil fuels, the industry was forced to seek higher efficiencies. This led to the development of the Molten Carbonate Fuel Cell (MCFC) and Solid Oxide Fuel Cell (SOFC). This was followed by development of the Proton Exchange Membrane (PEM) for small applications. These research and development efforts have been accelerated over the last ten years due to the global concern for the environment. The governments of Europe, Japan and the United States have subsidized research and development of these industries significantly in recent years [14,17]. The United States government alone has spent 40.21 million dollars in FY98 and plans on spending 42.2 million dollars in FY99 [2].

Currently, the PAFC is the only large-plant fuel cell that is commercially available as a turnkey system. The other cells can be obtained, but are still considered experimental in the United States. However, it does appear that the MCFC and SOFC plants will be commercially available within the next two to three years, [18] or at about the same time as the Department of the Navy would need to get the appropriation funding from Congress.

1.5 FUEL CELLS FOR THE DEPARTMENT OF DEFENSE

Fuel cell technology and its applications are not new to the Department of Defense. The 1993 Defense Appropriations Act required the United States Army, Air Force and Marine Corps to spend \$18 million equally divided for the implementation of fuel cells on their installations. This resulted in the purchase of 12 International Fuel Cells Corporation PC-25C's (a 200 kW power plant) in 1994. Since then, 18 additional plants have been

purchased. All of these are PAFC type plants and their applications include use at hospitals, dorms and barracks, as well as central plants. The facility types that use these plants are delineated in Fig. 1.2. Their co-generation capability has been applied to space heating, boiler water pre-heating and domestic hot water.

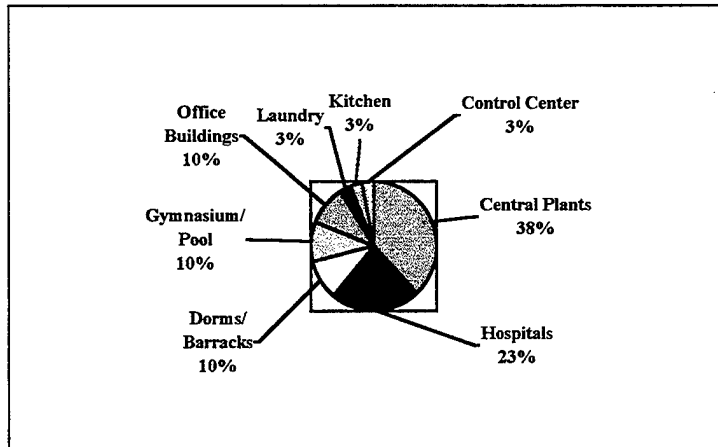

Figure 1.2 Facility Types Using PAFC Plants [19]

The cost savings obtained vary by co-generation applications and local utility costs. The DOD currently nets \$1,761,000 in savings per year with the use of these 30 plants [20]. The average availability of these units is 73.18 percent. This may be misleading, as low availability numbers can occur for various reasons, one of which is that the installation uses its steam plants in the winter and fuel cells in the summer due to the cost of fuel and the amount of steam required [21]. The appendix gives a detailed breakdown of these plants, their availability and cost avoidance, along with other data.

Additionally, the Department of the Navy in a joint venture with the Department of Energy (DOE) purchased an experimental MCFC unit. This 250kW unit at Miramar Naval Air Station is in operation as a co-generation unit providing electricity and 110 psi steam.

CHAPTER 2

FUEL CELL STACKS AND REFORMERS

2.1 INTRODUCTION

This chapter addresses the inner-workings of the different types of fuel cells that exist today. “Fuel cells offer a fundamentally new approach for generating electricity and usable heat from fossil fuels. Rather than combustion, fuel cells rely on an electrochemical reaction much like a battery”[2]. Unlike a battery though, they are not used up and later require charging. We will look at the chemistry that occurs and address the different characteristics for each type of fuel cell.

2.2 FUEL CELL REACTIONS

The chemical cycle of a fuel cell uses hydrogen rich fuel to supply a chemical reaction between hydrogen and oxygen. Hydrogen is fed over one electrode and oxygen over another. The electrodes are placed in an electrolyte bath. There are four different electrolyte chemical reactions to describe the different fuel cells in production today. The first is the alkali electrolyte; the second is acid and solid polymer, the third uses molten carbonate salt as the electrolyte, while the fourth uses a ceramic electrolyte. These reactions will be explained below.

2.2.1 Alkali Fuel Cells

An alkali cell has excess OH^- ions in the electrolytes, which play a key role in the chemical reactions of the cell. A potassium hydroxide (KOH) solution is the typical electrolyte used in an alkali cell. Hydrogen gas reacts with OH^- ions at the anode producing water and releasing electrons according to the following chemical reaction.

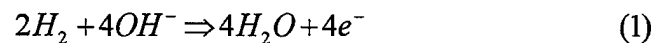

These free electrons flow from the anode to the load and back to the cathode. The second chemical reaction occurs at the cathode. These free electrons react with oxygen and water to form OH^- ions to be used at the anode.

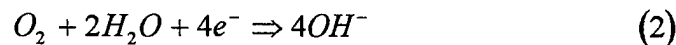

One should note that the rate of water production is twice as much at the anode as that used at the cathode. Hence the alkaline fuel cell can be used to produce water as a by-product [22].

2.2.2 Phosphoric Acid and Proton Exchange Fuel Cells

An acid cell and a solid polymer fuel cell have excess H^+ ions in the electrolyte, which play a key role in the chemical reactions of the cell. Phosphoric acid (H_3PO_4) is the most

common acid used in a fuel cell and nafion is the most common polymer electrolyte.

Hydrogen gas is ionized at the anode producing free electrons and H^+ ions.

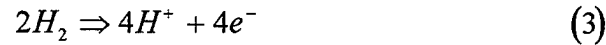

These free electrons flow from the anode to the load and back to the cathode. The second chemical reaction occurs at the cathode where the free electrons react with oxygen and the H^+ ions produced at the anode to form water.

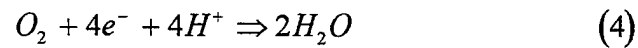

Because the solid polymer is very thin, it is referred to as a membrane. Since the H^+ ions that flow through the membrane are essentially protons, the solid polymer fuel cell is referred to as a “proton exchange membrane” or PEM [22].

2.2.3 Molten Carbonate Fuel Cell

The molten carbonate fuel cell has excess carbonate ions (CO_3^{2-}) in the electrolyte, which play a key role in the chemical reaction of the cell. Hydrogen gas is consumed at the anode producing free electrons and carbon dioxide.

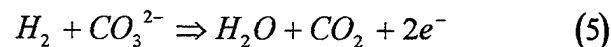

These free electrons flow from the anode to the load and back to the cathode. The chemical reaction at the cathode produces the carbonate ions when the carbon dioxide reacts with the free electrons and oxygen.

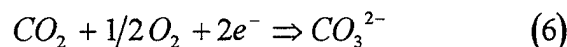

Like the alkali cell, water is formed at the anode and can be reclaimed for use elsewhere in the process [23,24].

2.2.4 Solid Oxide Fuel Cell

The solid oxide fuel cell has excess oxygen ions (O^{2-}) in the electrolyte, which play a key role in the chemical reaction of the cell. Hydrogen gas is consumed at the anode producing free electrons, water and carbon dioxide.

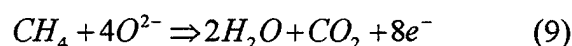
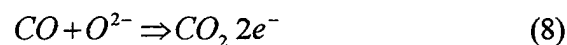
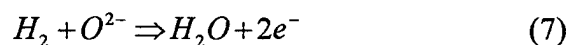

Equation (9) is less likely to occur than the gas water shift and the reforming reactions that will be discussed below [25]. The free electrons from these reactions flow from the anode to the load and back to the cathode. The chemical reaction at the cathode produces the oxygen ions when the oxygen reacts with the free electrons.



Again, water is formed at the anode and can be reclaimed for use elsewhere in the process.

All four processes use hydrogen rich fuel at the anode. Typically, the affluent is produced from natural gas or methanol but it can be others as well, to include coal gas, biogas, naphtha and logistic fuels. If the latter are chosen for use, a desulfurization process must occur first [4,11,24,26]. The process for taking natural gas or methanol and making a hydrogen rich gas is obtained by mixing the fuel with steam and passing it through a reformer.

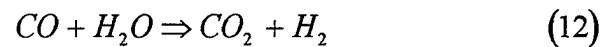
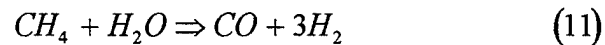

The first reaction (11) is called reforming and the second (12) is the gas water shift reaction. Both require the water in the form of steam. The heat required to generate the steam can be obtained by the waste heat of the fuel cell thereby improving efficiency [23,24].

2.3 FUEL CELL DESIGN FEATURES

We began our discussion of fuel cells with the chemical reactions, which show how the electricity is generated. The question still remains: what are the advantages of one type over the other, which means looking at all of the characteristics of each type of cell.

2.3.1 Phosphoric Acid Fuel Cells

The PAFC is considered a lower temperature fuel cell, operating at 200⁰ C (400⁰ F). This lower temperature restricts its use of fuels and it is sensitive to carbon monoxide poisoning of its anode at levels above 2% MOL, restricting it to natural gas or

methane[10,7]. The plant's efficiency is 40 percent for electric generation and 80 percent when co-generation is applied. The individual cell of a PAFC output voltage is so low that for practical use it needs to be connected in series. Economy of space and material dictates that we be able to "stack" the cells for higher voltage output. The cells are in a flat arrangement to help facilitate this stacking. The phosphoric acid is contained in a Teflon bonded silicone carbide matrix between two porous platinum coated carbon electrodes, which are sandwiched by conductive outer casing plates. These cells are then stacked, anode of one cell to the cathode of the next cell to electrically connect them in series.

The PAFC requires an external reformer where the fuel can be mixed with steam to undergo the reforming and gas-water shift chemical reactions. The fuel and oxidant gasses are fed to the cells via manifolds and the unspent fuel and product gasses are sent to mix with fuel to be burnt, providing the needed heat for the reformer [27]. The lower temperature limits the co-generation to hot water for space heating or absorption refrigeration for air conditioning units. This is further hampered by the fact that the 200 kW plant has to be at least 51 percent loaded in order to have enough rejection heat to be a viable co-generator. The ONSI PC25C unit can provide 700,000 Btu/hour of thermal energy [28]. See Table 2 for specific details.

Table Two [7,28]		
PAFC 200kW Plant (ONCI PC25C) Statistics		
	Anode	Cathode
Rejection Heat Temp	140°F	250°F
Rejection Heat BTU/hr	350,000	350,000

The United States Army's Natick Research, Development and Engineering Center in Massachusetts has successfully operated a PAFC plant since 1995. They use it to preheat boiler feed water and have saved a net of \$53,000 in utility charges each year [20]. See Table 3 for cost avoidance data.

Table Three [20]	
U.S. Army Soldier Systems Center Natick Mass	
Electric Savings	\$114,000
Thermal Savings	\$17,000
Total Savings	\$131,000
Natural Gas Cost	(\$78,000)
Net Savings	\$53,000
*all values per year	

2.3.2 Molten Carbonate Fuel Cell

The MCFC is considered a high temperature fuel cell, operating at 650⁰ C (1200⁰ F). This higher temperature allows for an internal reformer and a wide range of fuels to be used, to include logistical fuels. The plant's efficiency is near 60 percent for electrical generation and 85 percent for co-generation applications [3]. The waste heat for the MCFC can generate steam, heat water for space heating, run air conditioning plants and a pressurized fluidized bed gassification plant to preprocess fuels to generate hydrogen as well as produce boiler feed water quality water. The higher temperature also allows for the plant to have an internal reformer for the hydrogen rich fuel, rather than an external unit. Although these plants have achieved 40,000 hours of operation (approximately 5

years), the plant output deteriorates by approximately 0.25 percent per 1,000 hours, which is slightly higher than the established goal [29]. The current limiting factor is nickel shorting. This is caused by nickel oxide from the cathode being dissolved into the electrolyte. It then re-forms to nickel and provides an electrical path between anode and cathode. The industry is trying to determine what the correct operating pressure is to prevent this chemical reaction from occurring. The correction involves a problem with seals in order to pressurize the cells, but it should be overcome shortly.

All plant designs have a flat stackable cell component package that houses the anode, cathode, current collector separator plate and the carbonate matrix. The separator plate gets its name because it separates individual cells as well as channels the input gasses – hydrogen on one side and oxygen on the other. The plate is made of stainless steel, which gives it structural strength and electrically connects the cells together. The channeled fuel streams are distributed over the porous anode and cathode and the chemical reaction occurs. The free electrons produced at the anode of one cell are conducted through the separator plate and absorbed by the cathode of the next cell. Average cell output is “150 to 250 amperes per square foot (160-170 milliamperes per square meter) at 0.6 to 0.8 volts with 50 to 85 percent fuel utilization”. The end plates of the outer cells are then connected to an inverter to complete the circuit [30]. MCFC plants vary in size from 75 kW to 3 MW and there are two United States manufacturers – Energy Research Corporation and M-C Power.

2.3.3 Solid Oxide Fuel Cell

The SOFC is also a high temperature fuel cell. It operates at 1000°C (1800°F) and again, because of high temperature, it allows for a wide range of fuels and co-generation possibilities. The SOFC plant has a 60 percent electrical efficiency and a co-generation efficiency of 85 percent. The waste heat can easily run a fuel pre-processor as well as generate steam and provide HVAC systems for a facility. The SOFC plant is different from all other fuel cells in that even at operating temperatures, its elements are in a solid state. This allows it to be built in a non-planar form. Westinghouse Corporation has designed their SOFC plants in tubular cells, while other manufacturers continue to use stacked cells as in the PAFC and MCFC. A cutaway of the tube is shown in Fig. 2.1. This tube uses zirconia ceramics, which allow for the higher operating temperatures.

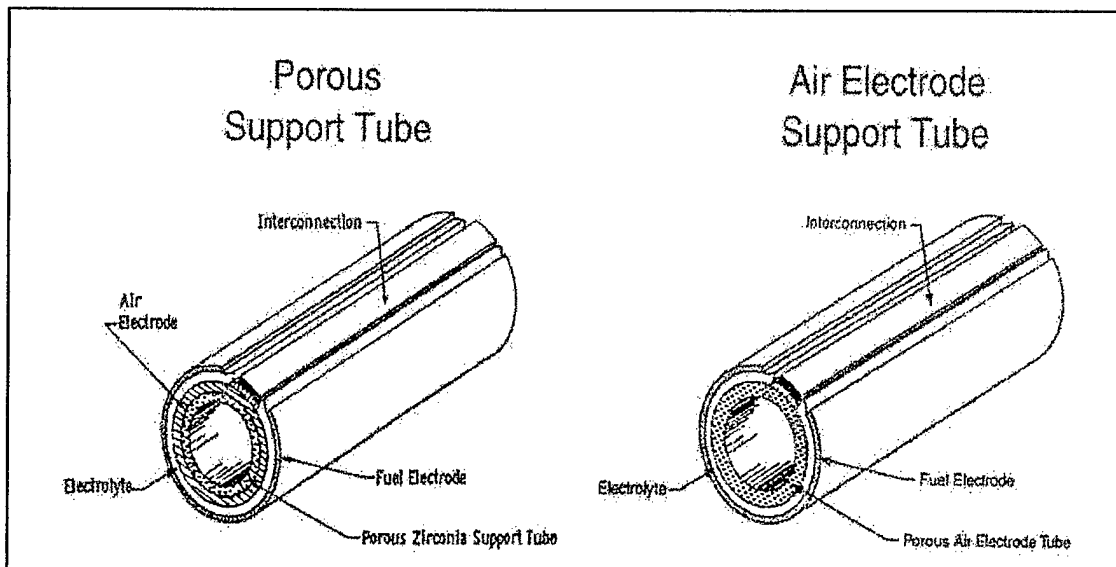

Figure 2.1 Evolving SOFC configuration: porous support tube and air electrode support tube [31]

This results in more efficiency per unit of fuel and substantially less carbon dioxide [8]. The tubes are bundled to form an array with the cathode via the interconnection pad which physically touches the outer casing (anode) of the adjacent tube. This is shown in

Fig. 2.1. Oxygen is introduced via a suspended pipe with a ball and socket joint at the upper end of the individual cells, as shown in Fig. 2.2. The hydrogen rich fuel is then introduced from the bottom (closed) end of the tube and flows between the cells. This design permits thermal expansion and allows the cells to be placed in a pressure vessel. The ability to pressurize the system gives a higher cell voltage output, improves efficiency of the unit and yields a high power output, 180-500 mA/cm² at 10 bars for 0.6 to 0.8 volts. This also provides an additional co-generation possibility, coupling the plant with a combustion turbine system [31].

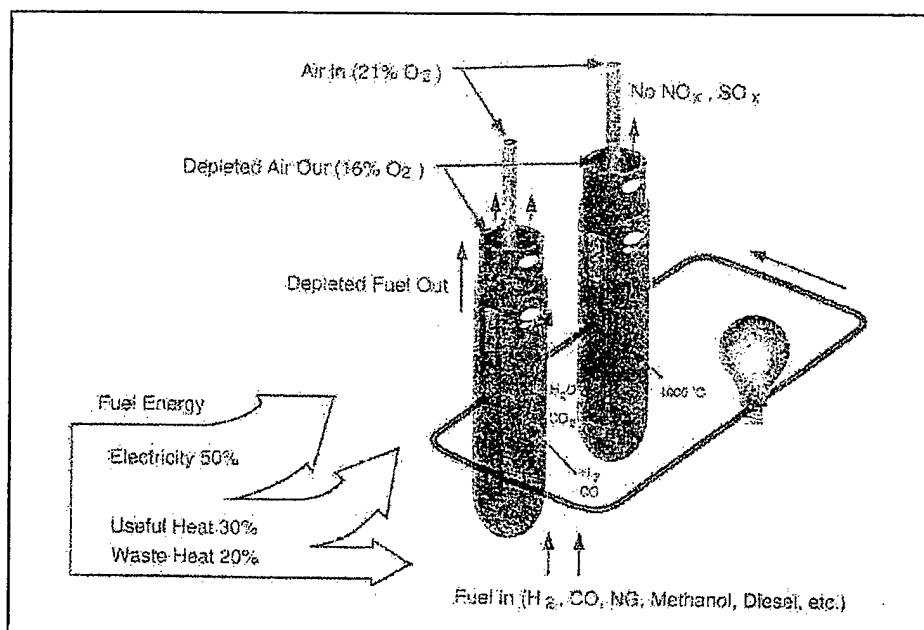

Figure 2.2 Schematic Representation of Westinghouse tubular solid oxide fuel cell [31]

2.3.4 Proton Exchange Membrane

The PEM is a low temperature fuel cell, operating at 80^o C (200^o F) with a 40 to 50 percent electrical efficiency, but has very limited co-generation capabilities. It is

constructed in a stack formation using a very thin composite pre-fluorinated polymer membrane. This is sandwiched by two gas diffusion layers that are held between two collector/separator plates made of graphite. Cooling of the stack is provided by de-ionized water that circulates throughout the stack and heat exchangers. Unlike the other fuel cells, the PEM produces only enough water to keep its membrane hydrated. The PEM produces 1.2 A/cm^2 and 3 kW/M^2 however, the plant size is smaller than any of its counter parts with plants ranging from 7 kW to 15 kW.

Table 4 gives us an overview of the characteristics of each fuel cell.

System	Temperature	Power Density in Stack (kW/m ²)	Electrolyte	Amperes	Size of Plant	Electrical Efficiencies	Over All Efficiencies
AFC - Alkaline Fuel Cell	60-90 °C	2	KOH 30%			70	70
PEFC - Polymer or PEM	50-80 °C	3	Nafion	410 mA/cm ²	Up to 20kw	40	40
PAFC - Phosphoric Acid	160-220 °C	1.3	H ₃ PO ₄		Up to 11 MW	40	60
MCFC - Molten Carbonate	620-660 °C	1.4	Li ₂ CO ₃ /Na ₂ CO ₃	160mA/cm ²	Up to 3 MW	60	85
SOFC - Solid Oxide	700-1000 °C	6	ZrO ₂ /Y ₂ O ₃ CeO ₂ /Gd ₂ O ₃	300 mA/cm ²	Up to 3 MW	60	85

CHAPTER 3

FUEL CELL POWER PLANTS

3.1 INTRODUCTION

While fuel cell stacks and reformers represent an important enabling technology, utilization of these components requires a complete plant design that is part of the larger electrical system and possibly a heating or air conditioning system. The other components in a fuel cell power plant and the configuration of the plant within the electrical system are described in this chapter.

3.2 BALANCE OF PLANT AND GRID CONFIGURATIONS

Although the fuel cell stack and reformer represent the most critical component of a fuel cell power plant, there are several other components that require consideration. These include a fuel handling unit, co-generation exhaust heat exchanger, and power conditioning sub-system. The relationship between all of these components in a fuel cell power plant is shown schematically in Fig 3.1. Objects indicated with circles represent energy sources or sinks.

As noted earlier, fuel cell plants can be incorporated into local electrical and HVAC systems in different ways. The choice for configuring the fuel cell depends on what the user wants to achieve with respect to power quality and control. The fuel cell plant has

basically three options as indicated in Fig. 3.2. The first is grid-independent/grid-connected. In this arrangement, the fuel cell is connected to the grid in a so-called

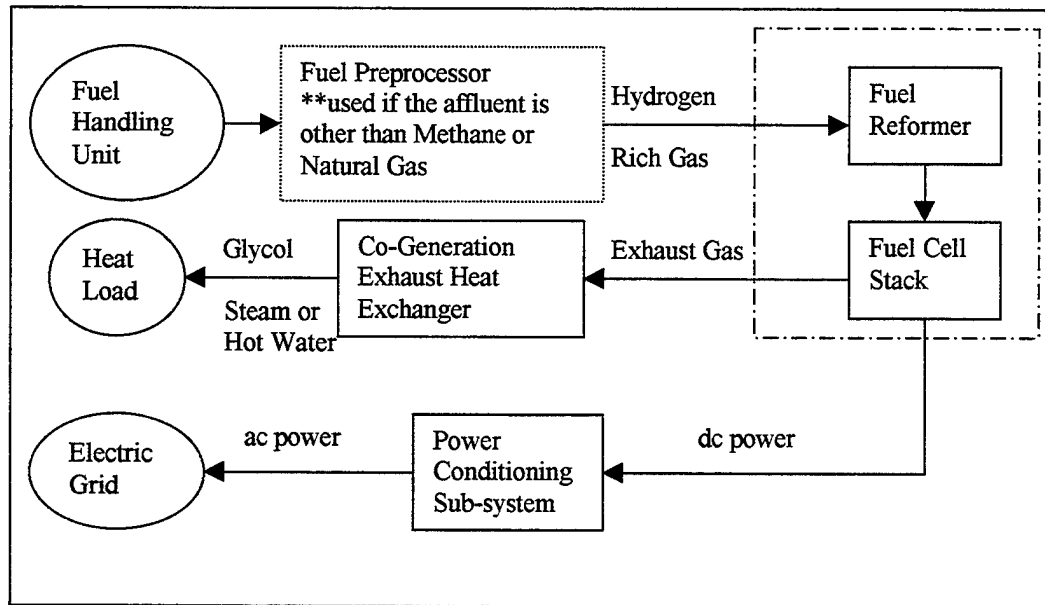

Figure 3.1 Generic Fuel Cell Power Plant

lag mode, in which the majority of the load is placed on the utility grid and a minimal amount of energy is being supplied from the fuel cell. If and when power is lost, the controller will automatically disconnect from the grid, switching to grid-independent mode and continue to supply power to critical loads [7]. This arrangement allows the fuel cell to act as an uninterruptable energy supply [35].

The second configuration is grid-independent/grid-synchronized. The difference between this arrangement and the first is that the fuel cell, although paralleled to the grid, is in the lead with most of the load. The control shifts the load to the grid if the fuel cell fails. The third operation is grid-independent. In this configuration, the fuel cell is the sole source for the load. It can also be paralleled with other cells to act as the source for a large load [7].

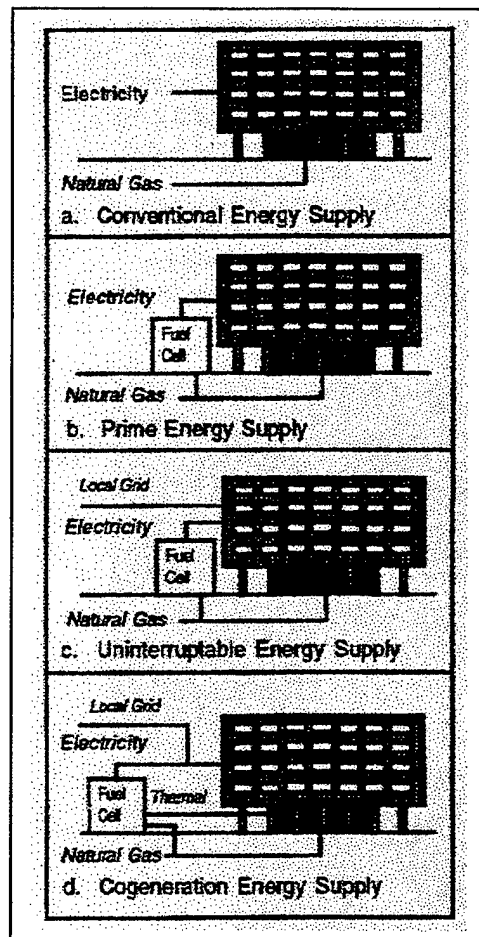

Figure 3.2 Configurations for Fuel Cell Grid Connections [7]

Regardless of configuration, the controller has to satisfy the system's demand for real and reactive power. An advantage of fuel cell power plants is that because the output is dc, it can handle real and reactive power by the way the power conditioning sub-systems (PCS) (or inverter) convert dc to ac.

3.3 POWER CONDITIONING SUB-SYSTEM

The device that converts electrical energy from dc to ac is called an inverter. Two general types of inverters can be used with fuel cells: naturally commutated converters and force commutated converters. These types are also referred to as line-commutated and Pulse Width Modulated (PWM) converters, respectively.

3.3.1 Line – Commutated Converters

Line commutated converters use a thyristor bridge between the dc and ac port as shown in Fig 3.3. Thyristors are the oldest of the solid state devices that can be used in very high power applications due to their on-state current rating and off state blocking voltage. The primary drawback with this technology is that during normal operation there is a high level of harmonics generated on both the ac and dc ports.

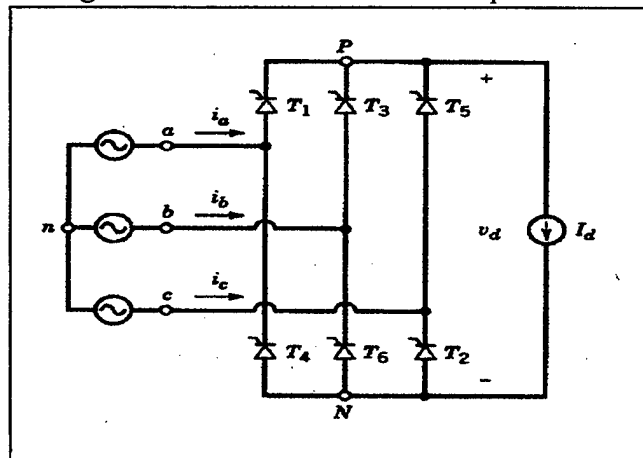

Figure 3.3 Three Phase Line Commutated Inverter [36]

This “line noise” is characterized by line notching and voltage distortion. To understand why these phenomena occur, we need to discuss the inner-workings of a line-commutated converter. As shown in Fig. 3.3, there are six thyristors or three thyristor pairs.

Thyristors operate like diodes in that when reversed biased, they block the flow of current. They are different from diodes because when forward biased, they do not conduct current until the thyristor is supplied a positive gate pulse of a short duration.

This gate trigger signal is usually coupled with the ac side voltage signal. By setting the gate trigger signal to a phase angle of the voltage, we can control the dc side waveform.

If the triggering angle is greater than 90° but less than 180° , V_d in Fig. 3.3 will be negative. The average power ($P_d = V_d I_d$) will also be negative and power will flow from the dc side of the converter to the ac side [36].

The thyristor operates in pairs with T_1 and T_2 , T_2 and T_3 , T_3 and T_4 , etc., conducting simultaneously. During transitions from one pair to the next, there is a so-called commutation process, during which all three of the thyristors involved in the successive pairs are on. The commutation process, as shown in Fig. 3.4, adds to voltage distortion and regulation difficulties, but this cannot be avoided. Having a higher inductance value to the converter can reduce but not eliminate this effect. "Owing to the increasing availability of better controllable switches in the high voltage and current ratings, new use of these thyristor converters nowadays is primarily in the three-phase applications"[36] and then for very high current ratings. The choice of using this system for fuel cells would only be considered if the need to reduce overall capital investment cost became necessary.

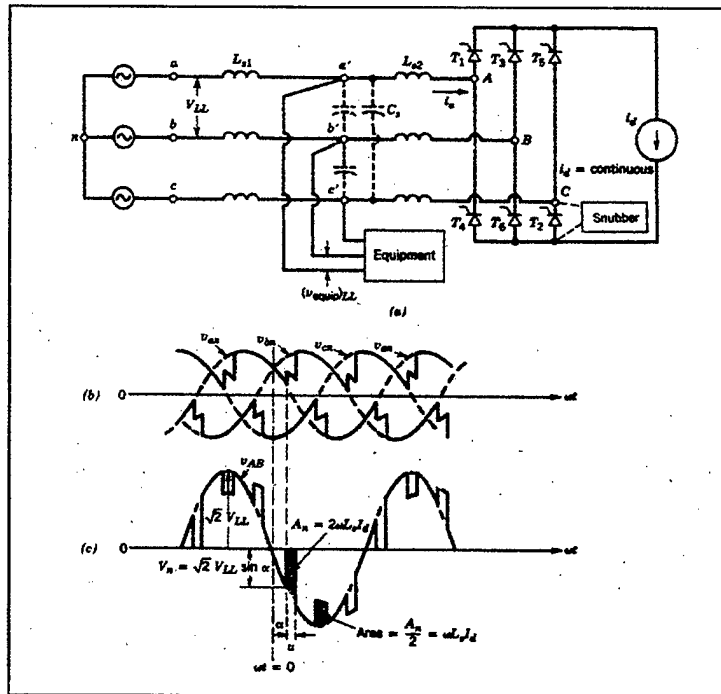

Figure 3.4 Line Notching Effect [36]

3.3.2 PWM Converters

There is an option in inverters today that provides power with minimal harmonic noise, called clean power. The use of high frequency semi-conductor switching devices makes active wave shaping possible. This process of wave shaping can be accomplished by waveform synthesis or by pulse width modulation [19].

As stated above, there have been advances in PWM technology that provides controllable switching at higher voltage and current ratings. The significance of this development is that fuel cells can use PWM converters.

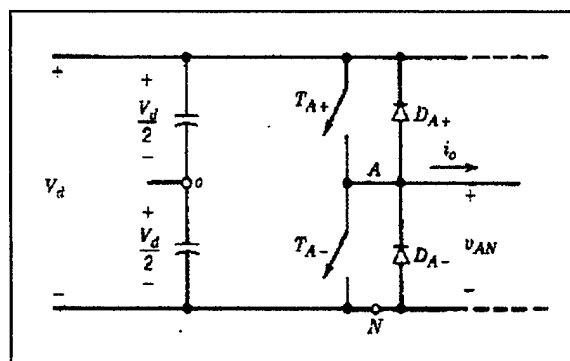

Figure 3.5 Single-phase PWM (single leg inverter) [36]

A PWM converter uses one inverter leg per phase. An inverter leg consists of two switches and two diodes in the arrangement shown in Fig. 3.5. Switching transitions are set-up with a sinusoidal control signal and a triangular waveform. The control signal is set at the designated frequency (f_1) and the triangular waveform is set at the carrier frequency with which the inverter switches will be switched (f_s).

The amplitude modulation ratio (M_a) is established as:

$$M_a = \frac{V_{\max \text{ control}}}{V_{\max \text{ tri}}} \quad (13)$$

The frequency modulation ratio (M_f) is established as:

$$M_f = \frac{f_s}{f_1} \quad (14)$$

The value of M_f should be kept small, ≤ 21 and be an integer. This will keep the carrier frequency synchronized with the control signal and prevent unwanted sub-harmonics.

Additionally, M_f should be an odd integer and a multiple of three. The results of choosing an odd integer for M_f gives symmetry $f(-t) = -f(t)$ and a half-wave symmetry

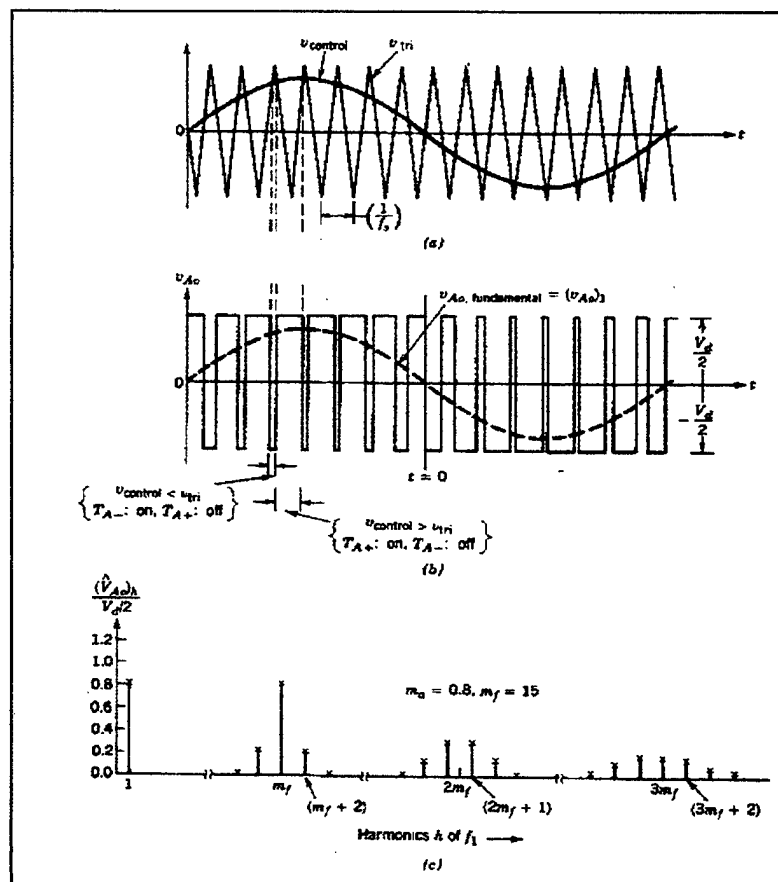

Figure 3.6 Single-phase PWM waveform and harmonics [36]

$[f(t) = -f(t + \frac{1}{2} T)]$ as shown in Fig. 3.6(b). This will eliminate the even harmonics in the output (V_{ao}) [36].

Since we are interested in three-phase line to line voltages, the harmonics are shown in Fig. 3.7(b). The phase difference between V_{AN} and V_{BN} is 120° so their M_f harmonics are $(120M_f)^\circ$. Therefore, if M_f is three or a multiple, the result of $(120M_f)^\circ$ will also be a multiple of 360° . The harmonic at M_f is suppressed as a result in the line-to-line voltage,

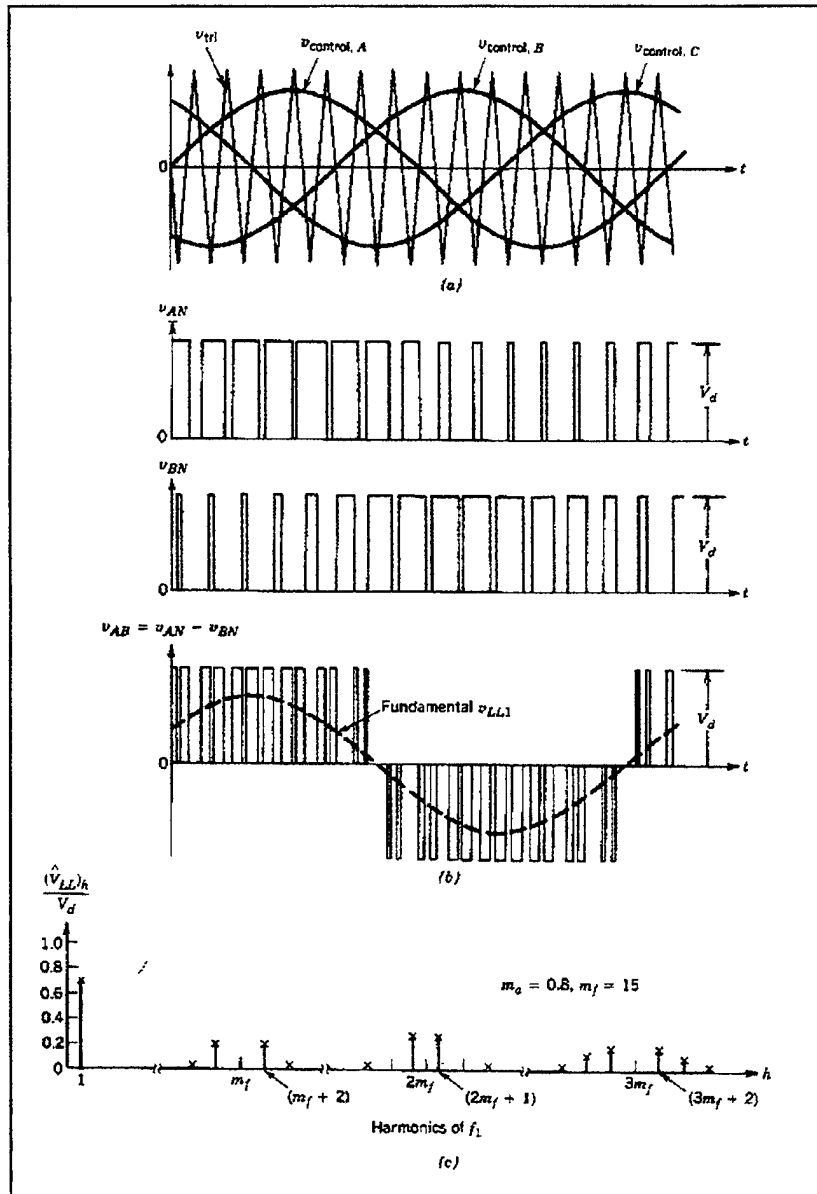

Figure 3.7 Three-phase PWM waveforms and the harmonic spectrum [36]

V_{AB} , because a harmonic of opposite amplitude occurs in the other phase at the exact same time. The same applies for the other line-to-line voltages. This phenomenon gives a PWM inverter a very noise clean output voltage.

3.3.3 Switching Control Strategies

Because the fuel cell can be used to control real and reactive power it is easier to achieve this by separating the real power control from the reactive power control. The fuel cell output is divided into two current components, which have the same fundamental frequency but different phase angles and different magnitudes. The phase angle of one component matches the phase angle of the voltage and provides control of the real power. This component is referred to as I_p . The second component is exactly 90° out of phase with the voltage and provides control of the reactive power. It is referred to as I_q . Mathematically, the total current, real power and reactive power injected into the grid can be expressed as:

$$I_{ac} = I_p + jI_q \quad (15)$$

$$P_{ac} = \sqrt{3}V_{ac}I_p \quad (16)$$

$$Q_{ac} = \sqrt{3}V_{ac}I_q \quad (17)$$

Alternatively,

$$P_{ac} = \sqrt{3}V_{ac}I_{ac} \cos\theta \quad (18)$$

$$Q_{ac} = \sqrt{3}V_{ac}I_{ac} \sin\theta \quad \text{where } \theta = \tan^{-1} \frac{I_q}{I_p} \quad (19)$$

The primary function of the PCS is to convert dc power to ac power and it is easier to separate the real power control from the reactive power control. If we change the switching sequence for the reactive power (jI_q) either forward or backward in time, we change the phase angle of the fundamental component without changing magnitude [19].

A schematic of the controller is shown in Fig. 3.8.

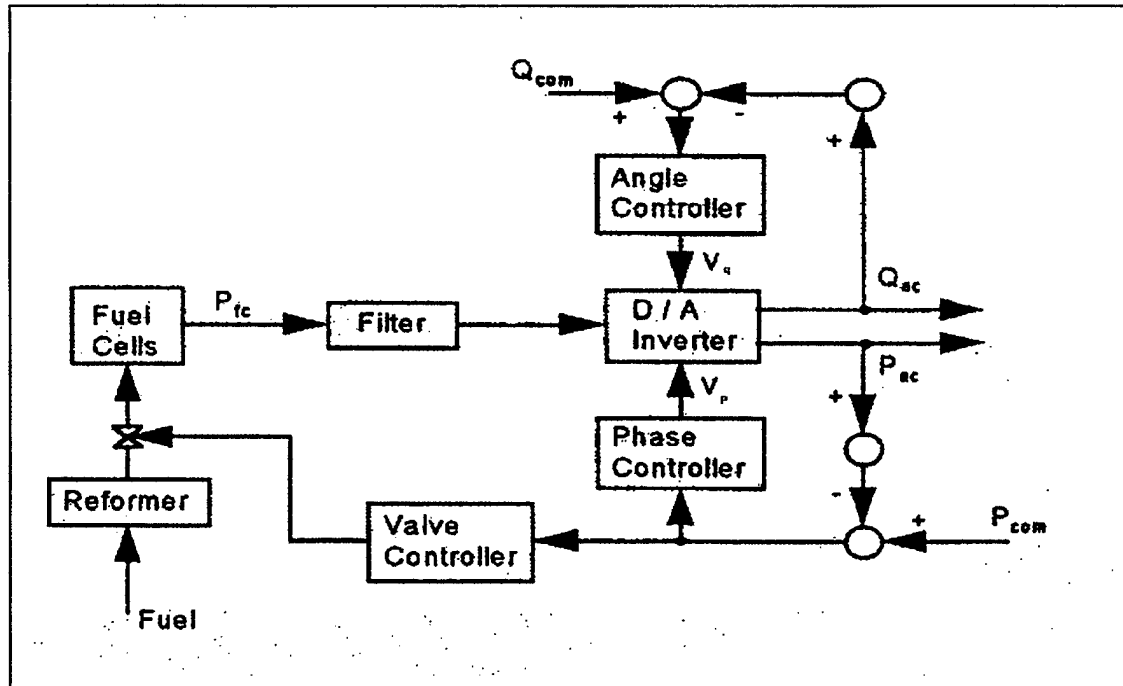

Figure 3.8 Block Diagram of a Controller for static VAR compensator [37]

The reactive power output from the fuel cell is compared to the required reactive power for the system. The angle controller receives the error signal from this comparison and adjusts its signal to the inverter, changing the switching sequence timing for the reactive power [37].

On the other hand, when the control operates the real power control, the comparison is made of required real power and real power output. The error signal is sent to the phase controller, which sends a signal to the inverter, changing switching schemes accordingly.

The error signal is also sent to the valve controller to increase or decrease fuel flow to the fuel cell [19,37].

From a utility standpoint, we can use a fuel cell and PCS controller as a static VAR compensator for stability enhancement and voltage control on a small scale. The fuel cell will have to be rated high enough to cover the range of the reactive power that we want to control (i.e. a -100 k VAR to +100 k VAR would require a 200 kW fuel cell) and the PCS would have to be rated slightly higher. Taking advantage of the fuel cells fast ramping characteristics and that we can turn off the PCS rapidly by blocking the switching signals, we can greatly reduce the fault current. This would allow circuit breaker ratings in the system to be reduced, providing economic savings. This concept has been successfully tested with a 40 MW photovoltaic fuel hybrid power plant [19]. This application has not yet come to fruition because it was not until recently that we have achieved 100 MW photovoltaic fuel hybrid power plant units in the United States, which would be necessary for the average load utility grid. These same options will become available to the user with fuel cell plants when they reach the 100 MW unit size.

3.4 FUEL HANDLING REQUIREMENTS

Fuel cells, because they normally operate on natural gas, do not require a special fuel-handling unit as such. The desulfurization of the natural gas is performed internal to the unit. A requirement for a slightly larger tap line from the main is needed for the proper cubic meter flow rate. The pressure from the gas main is reduced to 11 inches of H₂O and

pipled into the fuel cell. The manufacturer has safety shutdown devices within the modular unit if the volume of natural gas input exceeds the fuel cell consumption rate for that particular load. Because there are no moving parts in the reduction, the need for additional fire suppression is not required. This is true for natural gas, but if coal gas or logistics fuels are used then a traditional feed system (a conveyer in the case of coal, a fuel pump in the case of logistics fuel) and fire suppression system would be needed.

Chapter 2 indicated the basic chemical reactions necessary for each type of fuel cell. In each case, the affluent was hydrogen rich and “clean” low sulfur fuel. Methane in natural gas is converted with steam to make hydrogen in the reformer using the reactions described in equations (11) and (12). In order for use of fuels other than natural gas or pure methane, we need to be able to de-sulfurize, de-chlorinate and limit the carbon monoxide. Depending on the fuel used, this is accomplished by either a venture scrubber [11] or by a catalytic sulfur absorber followed by an adiabatic pre-conversion to convert the hydrocarbons to methane [26]. These processes allow the use of coal gas, bio mass and logistics fuels to be used as the affluent to a fuel cell. The conversion of the logistics fuels will be discussed in detail in Chapter 4.

3.5 HEAT EXCHANGERS

Most co-generation systems use the propylene glycol-water loop heat exchanger for thermal recovery from the exhaust gases. The standard installation of a heat exchanger is a double wall heat exchanger to meet local codes for potable water. The double wall prevents the possibility of glycol solution from contaminating the water supply if a leak

were to occur. The DOE recommends not using a Fuel Cell application with a highly sophisticated thermal recovery system because it makes the fuel cell cost prohibitive [7].

Chapter 4

PROPOSED SOLUTION

4.1 INTRODUCTION

We will assess if the requirements set in Chapter 1 for a different strategy to combat peak shaving can be met with fuel cell technology. The use of logistics fuels and the preprocessing that needs to occur will also be addressed in this chapter.

4.2 PROPOSED SOLUTION

Pier Services provide ships with steam for heating, hot water, galley service and steam jackets for boilers. Bunker fuel is used to fire the boilers in the winter and natural gas is used in the summer due to reduction in demand and the availability of natural gas on the spot market at a reduced price. Of the 2.2 million pounds per year of steam generated, 1 million pounds is clean steam sent to the piers for ship use. The 114,155 Btu/hour of clean steam required for the waterfront could be supplied by a fuel cell (the PAFC produces 350,000 Btu/hour at 250⁰F) [28]. However, the required pressure for the ship needs to be taken into consideration. The ship's systems are set to operate at 150 psi for boiler steam jackets and heating and 50 psi for galley, scullery and laundry services. This establishes the requirement of the steam to be 150 psi at 400⁰F (minimum 70 psi at 315⁰F) and boiler water/feedwater quality. The MCFC unit has been able to produce 110 psi steam for use in co-generation systems [33]. Therefore, it would be the better choice than the PAFC. The SOFC operating temperatures would also lend itself to this application.

Table 5			
Ship Power Requirements Pier-Side			
	Volts	Amps	kW
FFG	450	600-900	701.48
DD	450	1400-1800	1402.961
DDG	450	2100-2300	1792.672
CG	450	2200-2600	2026.499
LHD	450	3700-3800	2961.807
CV	450	4000-6800	5300.075

The second requirement for a fuel cell is the ability to remove the load from at least one ship per pier. Table 5 above shows typical loads for ships while in port. The 3 MW MCFC designed by the Energy Research Corporation meets these requirements. In fact, one unit could maintain a pier with a Guided Missile Cruiser and a Guided Missile Frigate. This same size unit could also handle two Destroyers. Regardless of how much load the ship actually taxes the fuel cell with, the efficiency of fuel use will be the same, unlike the ship operating its generators at partial load.

The third requirement is that the fuel cell be able to operate on logistics fuels. This is needed for three reasons. First, some installations are natural gas pipeline limited. Second, the natural gas lines, in most cases, do not go close to the pier areas. Third, the premise of our proposal is to use the same cost avoidance, in that the Navy has already purchased the logistics fuel being used for peak shaving. This hurdle can and has been overcome by a "brassboard logistic fuel processor"[26]. This technology has been tested with both the MCFC and SOFC units [26,38].

The use of logistics fuels requires an adiabatic pre-converter after desulfurizing the fuel. The brassboard processor was designed to handle the 0.5 weight percent according to military specifications for diesel fuel and reduce it to below 1 part per million. The tests were conducted with DF-2 and JP-8. This would be shifted to JP-5 or F-76 for Navy use, but it could be done and the piping infrastructure already exists. (JP-5 is a special test fuel of JP-8 [39] and tests are currently being conducted with positive results using F-76 to fuel the MCFC [40].)

Desulfurization is achieved by using a hydrodesulfurization catalyst, which converts the sulfur compounds in the fuel to hydrogen sulfide. The hydrogen sulfide is then absorbed in a zinc oxide bed. An added benefit of this procedure is that the aromatics content in the fuel cell is lowered, thereby preventing carbon formation from occurring when the fuel is converted to methane [26]. The resulting affluent is then converted to methane by an adiabatic process described in the following reaction:



This is followed by the reforming (11) and gas water shift (12) reactions discussed earlier. The brassboard and fuel cell block diagram proposed for this application is shown in Fig 4.1.

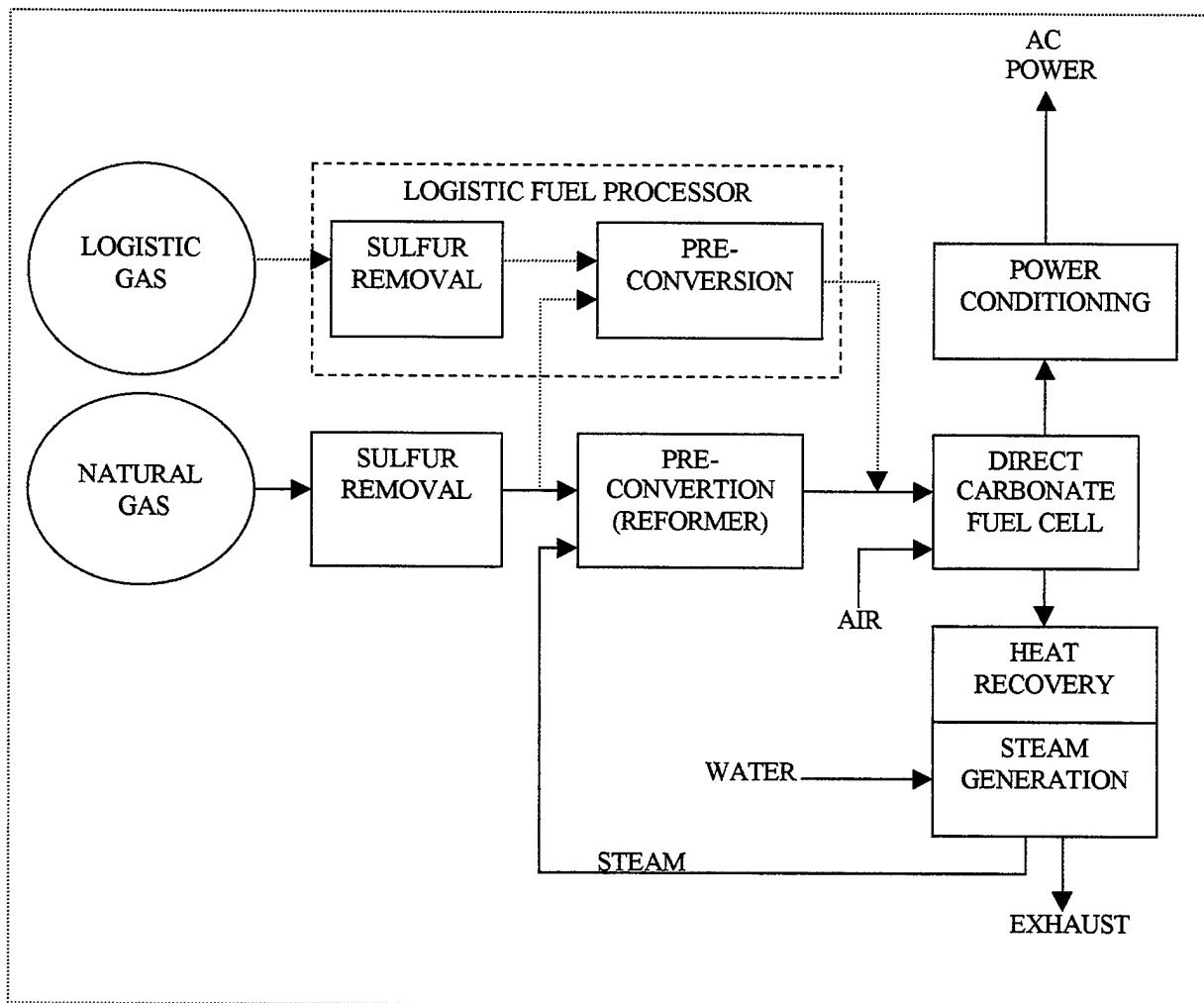

Figure 4.1 Brassboard and Fuel Cell Block Diagram [26]

The plant's efficiency while operating on diesel fuel is less than that of natural gas. A co-generation arrangement with the water generated by the fuel processor and the fuel cell generating clean steam was tested and the output of the plant is 2.81 MW versus 2.86 MW if natural gas is used and 57.3 percent efficiency versus 59.6 percent, respectively. The loss in efficiency and power output is caused by the power requirements of the fuel processor [26]. Table 6 gives a detailed breakdown of the system's performance.

Table 6 [26]				
Plant Design	Baseline Plant Design		Plant Design With Water Recovery	
Performance Case	Rated Output 59°F Diesel	Rated Output 59°F Natural Gas	Rated Output 59°F Diesel	Rated Output 59°F Natural Gas
Diesel Fuel:				
Feed Rate, LB/hr	921	-	905	-
Feed Rate Gal/hr	131		129	
LHV, MMBtu/hr	17.04		16.74	
Sulfur Content Wt.	0.3		0.3	
Natural Gas:				
Feed Rate, LB/hr	-	811	-	796
Feed Rate Scfm		298		292
LHV, MMBtu/hr		16.68		16.37
Sulfur Content Wt.		6		6
Water Makeup:				
Feed Rate, LB/hr	3,134	2,241	0	0
Feed Rate, Gal/min	6.3	4.5	0	0
Power Output:				
Fuel Cells, kW(dc)	2,998	3,009	3,008	3,016
Inverter Losses, kW	60	60	60	60
Auxiliary Power, kW	127	88	136	96
Net Output(480 V _{ac}), kW	2,811	2,861	2,812	2,860
Generation Efficiency:				
Overall Efficiency, % Fuel LHV to Power	56.3	58.5	57.3	59.6
Net Heat Rate, Btu/kWh	6,061	5,831	5,954	5,725

4.3 LIFE-CYCLE COSTS

The life-cycle costs for fuel cell power plants will be dependent upon the local costs for the affluent used and the kWh costs charged by the local utility, as well as the co-generation application being used. A detailed break down of the life-cycle cost calculations for considering replacement of a traditional electric and heating system with a fuel cell co-generation plant is available in Appendix B. The break-even comparison of natural gas costs to electrical costs is shown below in Fig. 4.2. The following

assumptions are made for Fig. 4.2: "75% of the available thermal energy can be used to replace an existing thermal system that operates at 85% efficiency"[7], and the cost of a 200 kW plant is \$650,000. In Fig.4.2, if the utility costs established by the application being considered fall below the curves, it is cost effective to purchase a plant.

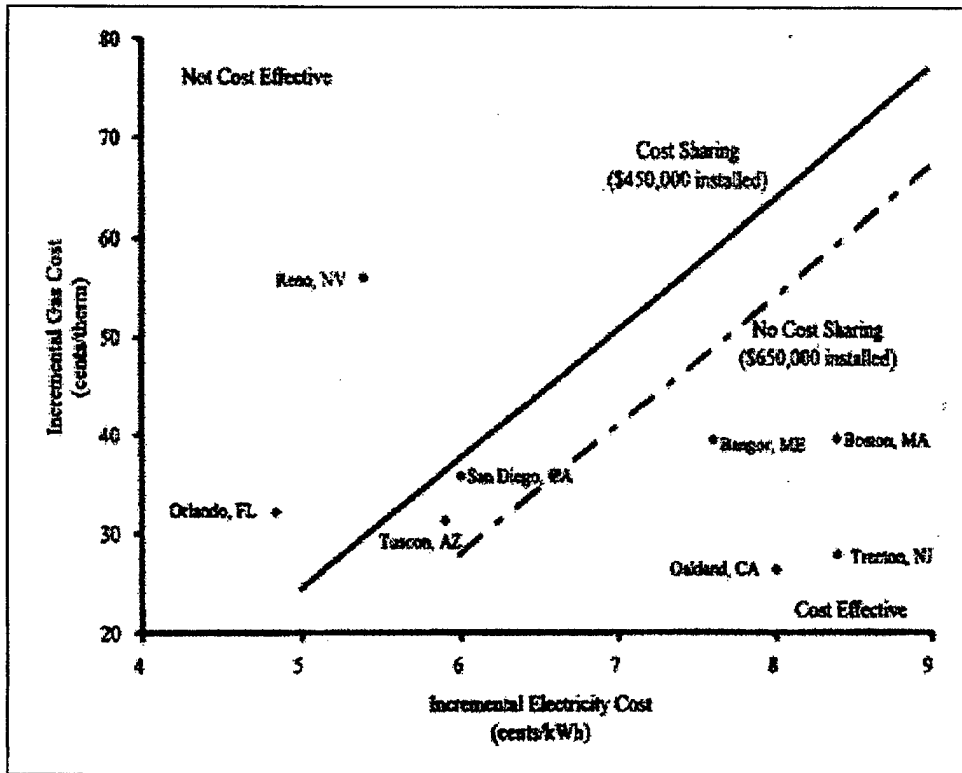

4.4 ECONOMY REALIZED

The MCFC is better than 56 percent efficient, leading to a 40 percent reduction in fuel consumption if diesel generator sets were used [26]. One person could monitor all fuel cells on the waterfront rather than two personnel per ship being effected. The maintenance of a fuel cell is estimated at \$26,000 per year, if operated year-round [27].

The cost to the Navy in maintenance and repair caused by light loading individual ships generators (not to mention how it effects readiness of the fleet) easily counters this cost.

The cost of installation has been the delay in this area. The DOE goal is \$1500/kW and the fuel cells initial expense was \$5000/kW and this has quickly been reduced to \$3000/kW. Manufacturers are continuing to strive to reach this goal, but recent setbacks have, in fact, raised the price of PAFC units. Currently, with the DOE offering to subsidize \$1000/kW of the capital cost for PAFC, both PAFC and MCFC are approximately \$3500/kW to the consumer.

Chapter 5

CONCLUSION

The Navy will need to upgrade its utility infrastructure in the coming years. It will be forced to comply with ever increasing environmental regulations and will still need to find and realize cost savings in energy consumption. Most importantly, it will need to take care of its sailors. These requirements will dictate that peak shaving continue, but by means other than simply ordering a ship to use its own generators.

The recent developments in fuel cell technologies make this form of power generation a viable alternative for many power issues. The capital investment incurred to purchase a plant has been the biggest stumbling block. Depending on the co-generation application, the PAFC plants have had a pay back period of less than 5 years, with the current DOD average being 7 years. The recent advances in manufacturing of the MCFC and SOFC bring their purchase cost within the same window of the cost of a PAFC as they enter the commercial market.

Admittedly, the track record of the MCFC has been less spectacular than first expected. One United States manufacturer seems to have overcome these problems as they pursue the development of ship service fuel cells. The other believes it has made the corrections necessary and this year's (ending June 2000) performance of the Miramar plant will prove if they have [41].

The introduction of the brassboard fuel processor increases the options available for the Navy to consider as it plans upgrades to its installation's utility systems. Minimal efficiency losses still ensure that the fuel cell out-performs a diesel generator or SSGTG. This, coupled with minimal or no additional pipeline infrastructure improvements, help to make the MCFC and SOFC the right choices for our purposes. Installing one near the pier, a plant fed with JP-5 or F-76 and operating in a grid-independent/grid-synchronized configuration for peak shaving and emergency situations gives the installation more versatility, to include static VAR compensation. This configuration would be ideal because the fuel cell could assume the load of the ship without the ship being inconvenienced in any way. In fact, it would be seamless to them.

The co-generation option of meeting the steam needs for the pier at the same time makes the payback time-line for the capital investment less. It additionally meets the desire to decentralize steam production on the installation.

Operation of a fuel cell is less manpower intensive than that of shipboard generators. The monitoring of all the plants could be handled by one or two persons, thus allowing shipboard personnel to work a normal day and still be able to spend quality time with their families.

Meeting the mission and taking care of our troops would be accomplished with this proposal. For all the economies realized and mentioned above, using fuel cells for peak shaving and alternative power for the piers is the right thing to do.

APPENDIX A

FUEL CELLS WITHIN THE DOD

Since 1993, the DOD and DOE have teamed together in an effort to stimulate the growth of the fuel cell industry and allow the DOD to reduce their utility expenditures in the future. This effort started with the purchase of 12 PAFC plants and more were added each year. The DOE and the Navy furthered this effort with the purchase of a MCFC in 1997, for use at Miramar Naval Air Station.

The map and chart [28] below include information on the PAFC plants that the DOD has purchased.

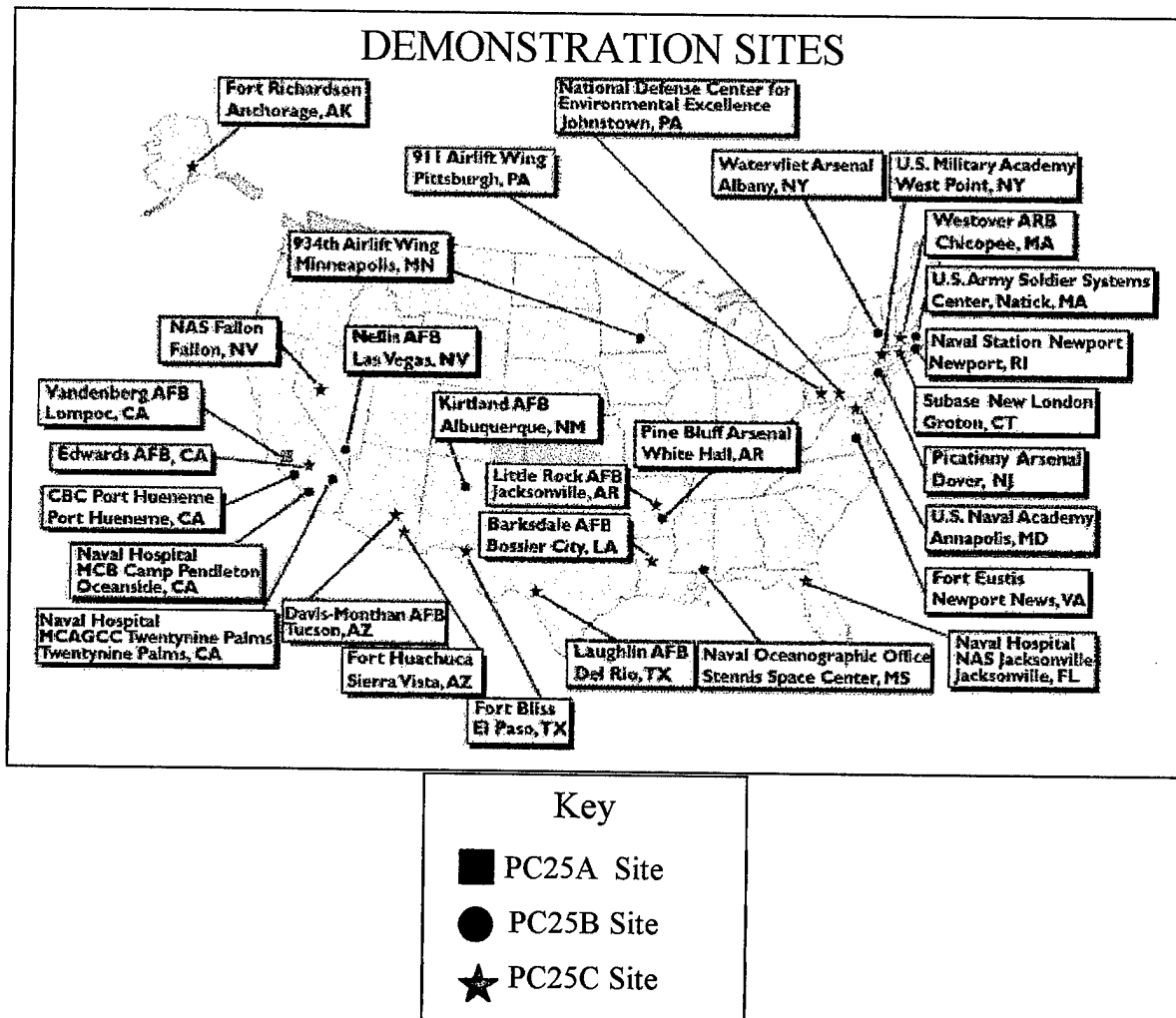

SITE NAME	PC25 MODEL	START DATE	OPER. HOURS	MWHR OUTPUT	AVG KW	ELEC. EFF.	AVAIL.
ARMY							
Fort Bliss	C	10/10/97	12,037	2,117.51	175.9		88.00%
Fort Eustis	B	9/12/95	11,455	2,144.61	187.2	32.40%	35.50%
Fort Huachuca	C	7/28/97	11,156	2,149.45	192.7		73.70%
Fort Richardson	C	12/17/96	13,200	2,321.95	175.9		62.60%
U.S. Army Soldier Systems Center	B	1/27/95	31,501	5,275.34	167.5	31.00%	83.20%
Picatinny Arsenal	B	10/11/95	20,380	3,793.79	186.1	31.60%	64.90%
Pine Bluff Arsenal	B	10/21/97	8,153	1,559.04	191.2	34.40%	60.30%
US Military Academy	B	11/17/95	23,558	4,161.30	176.6	31.90%	77.10%
Watervliet Arsenal	B	10/29/97	11,051	1,997.26	180.7	33.80%	83.70%
AIR FORCE							
911th Airlift Wing	C	12/18/96	16,914	3,174.40	187.7		83.00%
934th Airlift Wing	B	2/1/95	26,021	4,191.12	161.1	29.00%	70.10%
Barksdale AFB	C	7/24/97	12,226	2,379.51	194.6		78.90%
Davis-Monthan AFB	C	10/14/97	9,891	1,920.65	194.2		71.10%
Edwards AFB	C	7/5/97	8,895	1,714.27	192.7		52.80%
Kirtland AFB	B	7/20/95	14,136	2,084.22	147.4	31.20%	42.10%
Laughlin AFB	C	9/16/97	10,898	2,145.47	196.9		77.30%
Little Rock AFB	C	8/17/97	12,180	2,299.00	188.7		88.00%
Nellis AFB	B	9/23/95	16,687	2,845.94	170.5	29.60%	52.00%
Vandenberg AFB	A						
Westover AFB	C	9/19/97	12,466	2,455.79	197		88.40%

SITE NAME	PC25 MODEL	START DATE	OPER. HOURS	MWHR OUTPUT	AVG KW	ELEC. EFF.	AVAIL.
NAVY/MARINES							
CBC Port Hueneme	B	9/18/97	6,711	1,322.92	197.1	36.50%	46.10%
Naval Hospital MCB Camp Pendleton	B	10/6/95	20,103	3,504.91	174.3	32.70%	64.20%
NAS Fallon	C	3/30/97	14,446	2,553.34	176.7		76.00%
Naval Hospital NAS Jacksonville	C	3/18/97	14,657	2,718.73	185.5		79.30%
Naval Station Newport	B	1/23/95	30,860	4,852.59	157.2	30.30%	81.40%
Naval Oceanographi c Office	B	10/7/97	11,082	1,980.02	178.7	35.90%	78.90%
Subase New London	C	9/30/97	13,016	2,509.28	192.8		94.00%
Naval Hospital MCAGCC Twentynine Palms	B	6/20/95	18,467	3,097.01	167.7	31.70%	54.00%
US Naval Academy	C	9/22/97	11,776	1,627.90	138.2		84.50%
OTHER:							
NDCEE	C	8/14/97	9,337	1,145.80	122.7		60.50%
TOTAL/AVG:			433,272	76,043.10	175.5	31.60%	70.70%
<p>* Model C units do not have natural gas or electrical efficiency data. Disclaimer</p> <p>Electrical efficiency calculations include fuel cell idle time (such as when the fuel cell is awaiting the return to operation of the utility grid, etc.). If values were adjusted for idle time, fuel cell electrical efficiencies would be higher. ONSI fuel cells passed DoD Fuel Cell Program electrical efficiency criteria during unit acceptance tests (range = 33.5% to 37.2%, Higher Heating Value).</p> <p>Availability values are not adjusted for times when the fuel cell was down for extended periods unrelated to typical fuel cell operation (delays in maintenance personnel response, site operating conditions, etc.). Adjusting for these times would result in higher availability values.</p>							

Service/ Site Name	Building Application	Thermal Application	Thermal Utiliza.	Grid- Indep.	Est. Savings
ARMY					
Fort Bliss	Laundry	Process Hot Water	90%	--	\$59,000
Fort Eustis	Swimming Pool	Pool Water/DHW	55%	YES	\$35,000
Fort Huachuca	Barracks	Space Heat/DHW	44%	---	\$67,000
Fort Richardson	Armory Building	Space Heat/DHW	45%	YES	\$67,000
U.S. Army Soldier Systems Center	Boiler Plant	Make-up/Condensate	45%	---	\$53,000
Picatinny Arsenal	Boiler Plant	Boiler Make-up Water	100%	---	\$94,000
Pine Bluff Arsenal	Boiler Plant	Boiler Make-up Water	90%	YES	\$63,000
US Military Academy	Boiler Plant	Boiler Make-up Water	70%	---	\$30,000
Watervliet Arsenal	Central Boiler Plant	Boiler Make-up Water	58%	YES	\$76,000
AIRFORCE					
911th Airlift Wing	Central Heat Plant	Space Heat	29%	--	\$44,000
934th Airlift Wing	Boiler Plant	Make-up/Condensate	39%	--	\$25,000
Barksdale AFB	Hospital	Space Heat/Reheat	90%	--	\$40,000
Davis-Monthan AFB	Gymnasium	DHW/Absorp Chiller	65%	--	\$61,000
Edwards AFB	Hospital	DHW/Space Heat	23%	--	\$96,000
Kirtland AFB	Boiler Plant	Boiler Make-up Water	56%	--	\$58,000
Laughlin AFB	Hospital	Space/Reheat/DHW	75%	--	\$41,000
Little Rock AFB	Hospital	Space Heat/Reheat	86%	--	\$91,000
Nellis AFB	Dorm/Centr al Plant	DHW/Showers	40%	--	\$38,000
Vandenberg AFB	-	-	-	--	-
Westover ARB	Central Boiler Plant	Make-up/Condensate	49%	--	\$54,000

Service/ Site Name	Building Application	Thermal Application	Thermal Utiliza.	Grid- Indep.	Est. Savings
NAVY/MARINES					
CBC Port Hueneme	Swimming Pool	Pool	92%	--	\$73,000
Naval Hospital MCB Camp Pendleton	Hospital	DHW	75%	--	\$97,000
NAS Fallon	Galley	DHW	9%	YES	\$58,000
Naval Hospital NAS Jacksonville	Hospital	Space /Reheat/DHW	56%	--	\$90,000
Naval Station Newport	Boiler Plant	Boiler Make-up Water	90%	--	\$103,000
Naval Oceanographic Office	Office Building	Space Heat/Reheat	12%	YES	\$39,000
Subase New London	Boiler Plant	Boiler Make-up Water	90%	---	\$98,000
Naval Hospital MCAGCC Twentynine Palms	Hospital	DHW	60%	YES	\$57,000
US Naval Academy	Academy Dormitory	Kithchen DHW	70%	---	\$38,000
OTHER:					
National Defense Center for Environmental Excellence (NDCEE)	Office/ Research	Chemical Evaporator	19%	--	\$16,000
<p>Notes:</p> <p>Service/Site Name - DoD service branch and fuel cell site.</p> <p>Building Application - Building type interfaced with fuel cell.</p> <p>Thermal Application - Building thermal load interfaced with the fuel cell.</p> <p>Thermal Utilization Percentage - Percentage of available fuel cell thermal output utilized by site as originally estimated in the Site Evaluation Report.</p> <p>Grid Independent - Whether the fuel cell is configured to provide electrical back-up to utility grid outages.</p> <p>Estimated Savings - Estimated annual fuel cell energy savings based on electric and natural gas/fuel oil (from displaced thermal load) savings and input natural gas cost for operating the fuel cell. Maintenance costs (included in DoD Program) are not included in savings estimate.</p>					

APPENDIX B

“Federal Life-Cycle Costing Procedures and the BLCC Software”

“Federal agencies are required to evaluate energy-related investments on the basis of minimum life-cycle costs (10 CFR Part 436). A life-cycle cost evaluation computes the total long-run costs of a number of potential actions, and selects the action that minimizes the long-run costs. When considering retrofits, sticking with the existing equipment is one potential action, often called the baseline condition. The life-cycle cost (LCC) of a potential investment is the present value of all of the costs associated with the investment over time.

The first step in calculating the LCC is the identification of the costs. *Installed Cost* includes cost of materials purchased and the labor required to install them (for example, the price of an energy-efficient lighting fixture, plus cost of labor to install it). *Energy Cost* includes annual expenditures on energy to operate equipment. (For example, a lighting fixture that draws 100 watts and operates 2,000 hours annually requires 200,000 watt-hours (200 kWh) annually. At an electricity price of \$0.10 per kWh, this fixture has an annual energy cost of \$20.) *Nonfuel Operations and Maintenance* includes annual expenditures on parts and activities required to operate equipment (for example, replacing burned out light bulbs). *Replacement Costs* include expenditures to replace equipment upon failure (for example, replacing an oil furnace when it is no longer usable).

Because LCC includes the cost of money, periodic and aperiodic maintenance (O&M) and equipment replacement costs, energy escalation rates, and salvage value, it is usually expressed as a present value, which is evaluated by

$$\text{LCC} = \text{PV}(\text{IC}) + \text{PV}(\text{EC}) + \text{PV}(\text{OM}) + \text{PV}(\text{REP})$$

where

PV(x) denotes "present value of cost stream x,"

IC is the installed cost,

EC is the annual energy cost,

OM is the annual nonenergy O&M cost, and

REP is the future replacement cost.

Net present value (NPV) is the difference between the LCCs of two investment alternatives, e.g., the LCC of an energy-saving or energy-cost-reducing alternative and the LCC of the existing, or baseline, equipment. If the alternative's LCC is less than the baseline's LCC, the alternative is said to have a positive NPV, i.e., it is cost-effective.

NPV is thus given by

$$\text{NPV} = \text{PV}(\text{EC}_0) - \text{PV}(\text{EC}_1) + \text{PV}(\text{OM}_0) - \text{PV}(\text{OM}_1) + \text{PV}(\text{REP}_0) - \text{PV}(\text{REP}_1) - \text{PV}(\text{IC})$$

or

$$NPV = PV(ECS) + PV(OMS) + PV(REPS) - PV(IC)$$

where

subscript 0 denotes the existing or baseline condition,

subscript 1 denotes the energy cost saving measure,

IC is the installation cost of the alternative (note that the IC of the baseline is assumed zero),

ECS is the annual energy cost savings,

OMS is the annual nonenergy O&M savings, and

REPS is the future replacement savings.

Levelized energy cost (LEC) is the breakeven energy price (blended) at which a conservation, efficiency, renewable, or fuel-switching measure becomes cost-effective ($NPV \geq 0$). Thus, a project's LEC is given by

$$PV(LEC * EUS) = PV(OMS) + PV(REPS) - PV(IC)$$

where EUS is the annual energy use savings (energy units/yr). Savings-to-investment ratio (SIR) is the total (PV) savings of a measure divided by its installation cost:

$$SIR = (PV(ECS) + PV(OMS) + PV(REPS))/PV(IC).$$

Some of the tedious effort of life-cycle cost calculations can be avoided by using the Building Life-Cycle Cost software, BLCC, developed by NIST. For copies of BLCC, call the FEMP Help Desk at (800) 363-3732" [7].

BIBLIOGRAPHY

- [1] No Author Given, "ABB Stal Launches GTX100 at 43MW with Dual Fuel DLE Capability," Turbomachinery International, May/June 1997, pp. 22-23.
- [2] Department of Energy Testimony to the House of Representatives, February 28, 1998.
- [3] www.fe.doe.gov/coal-power/fs_mcpwr.html, "Developing the Second-Generation Fuel Cell – The M-C Power Project".
- [4] Saifur Rahman and Kwa-Sur Tam, "A Feasibility Study of Photovoltaic Fuel Cell Hybrid Energy System," IEEE Transactions on Energy Conversion, Vol. 3, No. 1, 1988, pp. 50-55.
- [5] NAVSEA S9310-AC-HBK-010 August 1985, NSN 0910-LP-085-9200, "Commutator/Slipring Maintenance Handbook".
- [6] NAVSEA S9086-HB-STM-010/CH-233, NSTM Chapter 233, "Diesel Engines".
- [7] www.pnl.gov/fta/5_nat.html, "Federal Technology Alert – Natural Gas Fuel Cells".
- [8] www.fe.doe.gov/coal_power/fs_solox.html, "Developing the Solid Oxide Fuel Cell – The Westinghouse Corporation Project".
- [9] www.lomer.ethz.ch/~cklien/nonmet/sofc/sofc_news/ppm, "Solid Oxide Fuel Cell, Swiss Federal Institute of Technology".
- [10] R. A. Knight, M. Onischak and F. S. Lau, "Fuel Cell Power Plants Using Hydrogen from Biomass," Proceedings of the American Power Conference, 1998, pp. 586-591.
- [11] P. Reimer, J. H. Hirschenhofer and J. S. White, "Carbon Dioxide Capture in Molten Carbonate Fuel Cell Power Plants Fueled with Coal and Natural Gas," IECEC Energy System, Vol. 2, 1997, pp. 805-810.
- [12] L. Camara, M-C Power Corporation, Fax to Author, June 29, 1999.
- [13] S. Veyo, Westinghouse Corporation, Telephone Conversation with Author, June 22, 1999.
- [14] A. L. Dicks and M. R. Taylor, "Fuel Cell Power Systems Development in Europe," Energy and Environment, Vol. 9, No. 1, 1998, pp. 17-33.
- [15] R. J. Fiskum, "Fuel Cell for Building Program," IECEC Energy Systems, Vol. 2, 1997, pp. 796-799.

- [16] G. E. Voecks, et.al., "Operation of the 25kW NASA Lewis Research Center Solar Regenerative Fuel Cell Testbed Facility," Proceedings of IECEC Energy Systems, 1997, pp. 1543-1549.
- [17] www.fe.doe.gov/remarks/miramar_2_20_97.html, "Dedication of Miramar Naval Air Station Molten Carbonate Fuel Cell".
- [18] www.fe.doe.gov/coal_power/fc_sum.html, "Advanced Electric Power".
- [19] K. Tam, and S. Rahman, "System Performance Improvement Provided by a Power Conditioning Subsystem for Central Station Photovoltaic Fuel Cell Power Plant," IEEE Transactions on Energy Conversion, Vol. 3, No. 1, March 1988, pp. 64-70.
- [20] www.dodfuelcell.com, "Fuel Cell Descriptions".
- [21] D. Wood, Fort Eustis Public Works Department, Telephone Conversation with Author, June 8, 1999.
- [22] www.I-way.co.uk/~ectech/basics.html, "How does a Fuel Cell Work?".
- [23] M. D. Lukus, K. Y. Lee and H. Ghezel-Ayagh, "Development of Fuel Cell Stack Simulation Model for Control Study on Direct reforming Molten Carbonate Fuel Cell Power Plant," IEEE Transactions on Energy Conversion, PE-486-EC-0-01-1999.
- [24] R. Permal, S. Bali, M. Balakrishnam and A. Mathur, "Molten Carbonate Fuel Cells for Power Generation from High Ash Indian Coal," IECEC Energy System, Vol. 2, 1997, pp. 811-816.
- [25] J.H. Hirschenhofer, D.B. Stauffer, R.R. Engleman, and M.G. Klett, Fuel Cell Handbook Fourth Edition, Federal Energy Technology Center Morgantown WV 1998
- [26] S. G. Abens and G. Steinfeld, "Direct Carbonate Fuel Cell Power Plant Operating with Logistic Fuels," IECEC Energy System, Vol. 2, 1997, pp. 851-856.
- [27] www.itri.org.tw, "Fuel Cells – ITRI's Collaborative Program on Clean and Efficient Power Generators".
- [28] D. H. Archer, J. G. Wilmer and M. C. Williams, "A Phosphoric Acid Fuel Cell Co-Generation System Retrofit to Large Office Building," IECEC Energy Systems, Vol. 2, 1997, pp. 817-824.
- [29] T. Watanabe, "Fuel Cell Power System Applications in Japan," Proceedings of the Institution of Mechanical Engineers, Journal of Power and Energy, Part A, Vol. 211, 1997, pp. 113-119.

- [30] M. C. Williams, E. L. Parsons and M. J. Mayfield, "The U. S. Molten Carbonate Fuel Cell Development and Commercialization Effort," 29th IECEC Meeting, pp. 812-816.
- [31] F. Bevc, "Advances in Solid Oxide Fuel Cells and Integrated Power Plants," Proceedings of the Institution of Mechanical Engineers, Journal of Power and Energy, Part A, Vol. 211, No. 5, 1997, pp. 359-365.
- [32] F. Barbir, B. Bahar and J. A. Kolde, "Development of 10kW PEM Fuel Cell Stack with Advanced Membrane/Electrode Assemblies," Electrochemical Societies 190th Meeting, October, 1996.
- [33] T. G. Benjamin, D. S. Erikson and E. J. Haugh, "Status of the M-C Power MCFC Commercialization Program," IECEC Energy System, Vol. 2, 1997, pp. 800-804.
- [34] www.fuelcells.org/fuel/fctypes.html, "Fuel Cells: 2000 Types of Fuel Cells".
- [35] Y. Kuwata, T. Take, T. Aoki and T. Ogata, "Multi Fuel Cell Energy System for Telecommunications Co-Generation System," IECEC Transactions on Communications, Vol. E81B, No. 11, November 1998, pp. 2176-2182.
- [36] N. Mohan, T. M. Underland and W. P. Robbins, Power Electronics Converters. Applications and Design, John Wiley and Sons, Inc. New York, NY, 1995.
- [37] Ro Kyoungsoo and Saifur Rahman, "Two-Loop Controller for Maximizing Performance of a Grid Connected Photovoltaic Fuel Cell Hybrid Power Plant," IEEE Transactions on Energy Conversion, Vol. 13, No. 3, September 1998, pp. 276-281.
- [38] John H. Hirschenhofer, "Fuel Cell Status," 29th IECEC Meeting, 1994, pp. 806-811.
- [39] MIL-DTL-5624T 18 September 1998, Military Specifications for JP-5.
- [40] G. Steinfeld, R. Sanderson, J. Woerner and M. Cervi, "Concept Development of a Ship Service Fuel Cell," International Fuel Cell Symposium.
- [41] L. Camara, M-C Power Corporation, Telephone Conversation with Author, June 22, 1999.