

REPORT DOCUMENTATION PAGE			Form Approved OMB No. 0704-0188		
Public reporting burden for this collection of information is estimated to average 1 hour per response, including the time for reviewing instructions, searching data sources, gathering and maintaining the data needed, and completing and reviewing the collection of information. Send comments regarding this burden estimate or any other aspect of this collection of information, including suggestions for reducing this burden to Washington Headquarters Service, Directorate for Information Operations and Reports, 1215 Jefferson Davis Highway, Suite 1204, Arlington, VA 22202-4302, and to the Office of Management and Budget, Paperwork Reduction Project (0704-0188) Washington, DC 20503.					
PLEASE DO NOT RETURN YOUR FORM TO THE ABOVE ADDRESS.					
1. REPORT DATE (DD-MM-YYYY) 01-09-1999		2. REPORT DATE Annual Performance Report		3. DATES COVERED (From - To) 1 JULY 1999-30 SEPT 1999	
4. TITLE AND SUBTITLE VISUAL GAIT MODIFICATION 1 ST YEAR TECHNICAL REPORT			5a. CONTRACT NUMBER N/A		
			5b. GRANT NUMBER N00014-99-1-0984		
			5c. PROGRAM ELEMENT NUMBER N/A		
6. AUTHOR(S) LEWIS, M. ANTHONY ETIENNE-CUMMINGS, RALPH			5d. PROJECT NUMBER N/A		
			5e. TASK NUMBER N/A		
			5f. WORK UNIT NUMBER N/A		
7. PERFORMING ORGANIZATION NAME(S) AND ADDRESS(ES) THE JOHNS HOPKINS UNIVERSITY HOMEWOOD RESEARCH ADMINISTRATION 105 AMES HALL 4300 NORTH CHARLES ST BALTIMORE, MD 21218-2686			8. PERFORMING ORGANIZATION REPORT NUMBER N/A		
9. SPONSORING/MONITORING AGENCY NAME(S) AND ADDRESS(ES) OFFICE OF NAVAL RESEARCH ONR 252: DIANE GALES BALLSONT CENTRE TOWER ONE 800 NORTH QUINCY STREET ARLINGTON, VA 22217-5660			10. SPONSOR/MONITOR'S ACRONYM(S) ONR		
			11. SPONSORING/MONITORING AGENCY REPORT NUMBER N/A		
12. DISTRIBUTION AVAILABILITY STATEMENT APPROVED FOR PUBLIC RELEASE					
13. SUPPLEMENTARY NOTES					
14. ABSTRACT THIS REPORT DESCRIBES FIRST YEAR ACTIVITIES IN DEVELOPING A NEURAL MODEL OF VISUALLY GUIDED STEPPING HOSTED IN A WALKING MACHINE. WORK IN THE DEVELOPMENT OF A NEURAL CPG CHIP, AS WELL AS A A MODEL OF VISUALLY TRIGGERED GAIT MODIFICATION IS DESCRIBED.					
15. SUBJECT TERMS					
16. SECURITY CLASSIFICATION OF:			17. LIMITATION OF ABSTRACT	18. NUMBER OF PAGES	19a. NAME OF RESPONSIBLE PERSON
a. REPORT	b. ABSTRACT	c. THIS PAGE			19b. TELEPHONE NUMBER (Include area code)

Standard Form 298 (Rev. 8-98)
Prescribed by ANSI-Std Z39-18

DTIC QUALITY INSPECTED 4

19990903 149

Visual Gait Modification 1st Year Technical Report

Grant No. N00014-99-0984

Dr. Thomas McKenna, Program Officer

July 1, 1999-September 30, 1999

Prepared by

M. Anthony Lewis
Iguana Robotics, Inc

Ralph Etienne-Cummings
The Johns Hopkins University

Abstract- This report describes first year activities in developing a neural model of visually guided stepping hosted in a walking machine. Work in the development of a neural CPG chip, as well as a model of visually triggered gait modification is described.

1. Introduction

The collaboration between The Johns Hopkins University and Iguana Robotics, Inc. has gotten off to a good start. In early July the PIs tested an aVLSI CPG chip by controlling a robotic leg running on a rotating drum. We were able to establish the basic functionality of the chip and show that it could be used in closed loop to control a simple leg. The results of this experiment are described in Section 2.

Secondly, we revised and prepared for publication an article for a special issue of Connection Science on the topic of Adaptive Robots. This article details a model of visually triggered gait modification. This article has been accepted for publication and should appear later this year in a special issue on adaptive robots.

Thirdly, administrative issues have been addressed and the subcontract agreement between The Johns Hopkins University and Iguana Robotics, Inc. has been completed.

Finally, at a meeting held at The Johns Hopkins University on August 22nd and 23rd, the PIs outlined plans for work until the end of this calendar year. The major points discussed are shown in Section 5.

Also worth mentioning is that our current work is drawing interest from researchers and neuromodelers. Avis Cohen at the University of Maryland is interested in the possibility of applying the neural chip technology in the restoration of function to paraplegics. The PIs have met with Professor Cohen several times since July to discuss the collaboration. Also of interest, Nicolas Schweighofer, a research scientist in Kawato's lab at ATR in Japan has offered to adapt a model of cerebellar learning for use in the task of visually guided walking. We are optimistic that this collaboration will allow us test an established model of the cerebellum in the task of robot control.

2. Control of a robotic leg using a CPG

This project focused around the evaluation of a CPG chip previously designed and fabricated by the PIs. This project was carried out during the Telluride Neuromorphic Engineering Workshop. This work was done in collaboration with Avis Cohen, University of Maryland, and Mitra Hartmann, from the Bower lab at Caltech.

2.1. Objective

We achieved preliminary results in the control of a robotic leg using a custom aVLSI neural circuit. The long range intention is to integrate this chip with other chips to achieve the goal of visually triggered gait modification. Currently we are interested in evaluating the strengths and weaknesses of the current design.

The objective of this particular experiment was to:

- (1) Demonstrate an adaptive CPG modeled as in aVLSI.
- (2) To control the hip joint of a robot leg using the output of the CPG chip.
- (3) Use sensory feedback, emulating stretch receptors, from the hip joint to control the resetting of the CPG.

2.2. Physical Step-Up

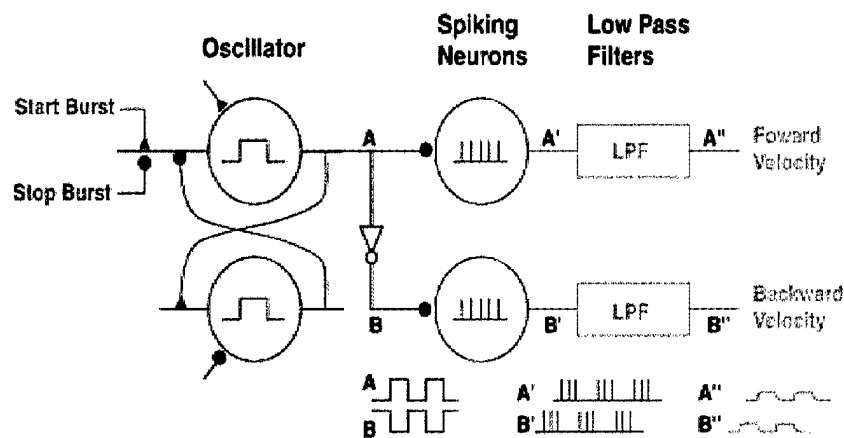

Figure 1 On chip functions of the CPG chip.

In Fig 1 we see a diagram of the functions provided on the CPG chip. Two neurons are connected with mutually inhibitory connections. These connections enforce a basic coordination between the CPGs. These are non-spiking, graded response neurons with hard threshold non-linearities. These neurons can be reset by external signals.

These neurons are then used to drive spiking or bursting neurons. These neurons would be analogous to motor neurons. In the normal mode, bursts of activity alternate from these two neurons.

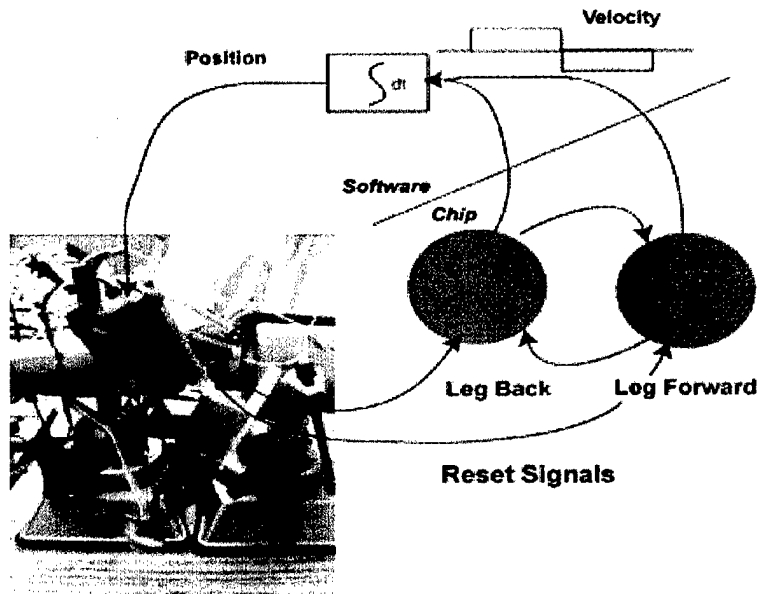

Figure 2. System diagram. A coupled pair of CPGs generate extensor and flexor commands. These commands are integrated in software and the resulting position command is used to drive the hip joint of the leg. Sensor output from the hip joint is used to reset the CPGs.

These neurons were then interfaced to a servo motor using a rudimentary muscle model. A diagram showing the connection to a robot leg is shown in Fig 2.

The leg also included sensors on the passive knee joint as well as a foot pressure sensor. These were used to measure the performance of the system. The only sensory feedback is from the muscle as is used to reset the CPG.

2.3. Results

An experiment was performed demonstrating the ability of the stretch reflex to stabilize the running. Some of the results are shown in Fig 3. Here we see that the stretch

reflex significantly stabilizes the gait of the robot.

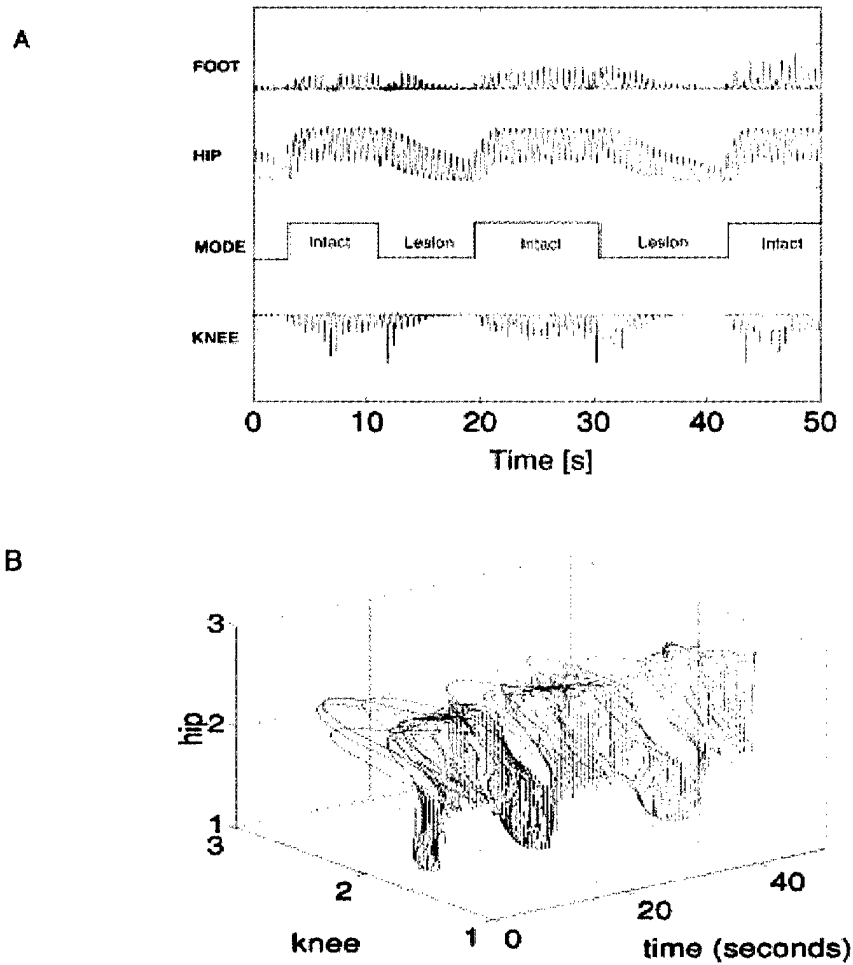

Figure 3. Leg control results. (A) We see the effect of lesions the sensory feedback. The hip position of the leg drifts downward (indicating a backward drift) when sensory feedback is lesioned. (B) This graph shows that during lesions, the Hip and knee position versus time. In the regions colored in red, magenta and blue, we see that the trajectories appear very regular. In dark blue, black, and green, we see that the trajectories degenerate when the sensory feedback is lesioned.

We noted that in this particular chip, there was difficulty in adjusting the phase difference between the graded response neurons comprising the CPG.

Using this simple experimental setup we were able to evaluate the performance of the CPG chip. We demonstrated the ability to generate burst of spiking output, to drive a leg and to be controlled using sensory feedback.

An interesting result was that the knee could be driven passively by the dynamics of the interaction of the ground and forced transmitted from the upper limb. The graph in Fig 3 (B) shows the remarkably regular pattern between the knee and hip even though the *knee joint is purely a passive joint*.

Certain issues were identified in this chip. They center on the issue of parameter sensitivity. We found that certain parameters (such as the phase difference between the CPG) were much too sensitive to small variations in input parameters. As a result, it was impossible, for practical purposes, to adjust certain parameters of the CPG bursting. This problem will be addressed in the next iteration of the chip.

Other features of the chip include the ability to adjust the burst length (the duration of the spikes going to either extensor or flexor), the frequency of bursting (or the inter-spike interval).

3. Publications and Presentation.

The following paper has been accepted for publication in the Journal Connection Science:

“Elegant Stepping: A model of visually triggered gait modification.” M. Anthony Lewis and Lucia S. Simó. This paper will be published later this year.

Avis Cohen will present the work described in Section 2 at the 2nd European Workshop on Neuromorphic Systems (EWNS2) 3-5 September 1999 held in Sterling, Scotland.

4. Administrative

1. A subcontract agreement between Iguana Robotics, Inc. and The Johns Hopkins University was negotiated and signed on August 16th, 1999.
2. An account was setup at JHU for Etienne-Cummings

3. An organizational meeting was held at JHU on August 23rd -24th to discuss the project organization and outline plans for the rest of the calendar year.

5. Plans for October 1st-Dec 31st

The objective for this quarter is to build create advance the current model of the visually triggered gait modification develop the hardware infrastructure needed to perform systematic experiments in a real system. Specifically:

1. A computer interface between existing neuromorphic chips and a computer system will be developed. This will allow the real-time transfer of data to a computer. The computer will then use this information in a real-time simulation.
2. A new CPG chip will be fabricated.
3. The simulation will be extended to include a more biologically realistic cerebellar model as well as using realistic synthetic visual data.
4. A leg of Geo III will be designed and fabricated.
5. A robot treadmill suitable for a small robot, will be purchased or developed. This will be a small treadmill that will allow a robot to walk on a continuous surface.
6. A miniature vergence (dual pan-tilt) device will be fabricated. This will be used as part of a system to measure distances to obstacles.