



**STRATEGY
RESEARCH
PROJECT**

The views expressed in this paper are those of the author and do not necessarily reflect the views of the Department of Defense or any of its agencies. This document may not be released for open publication until it has been cleared by the appropriate military service or government agency.

**SEAMLESS TOTAL ARMY RECRUITING:
A CONCEPT FOR ARMY AFTER NEXT**

BY

**LIEUTENANT COLONEL CHRISTINE T. MARSH
COLONEL JODI S. TYMESON
HARVARD UNIVERSITY
AND
COLONEL LEONARD J. SAMBOROWSKI
MASSACHUSETTS INSTITUTE OF TECHNOLOGY**

Senior Service College Fellows, U.S. Army

**DISTRIBUTION STATEMENT A
Approved for Public Release
Distribution is Unlimited**



USAWC CLASS OF 1999

U.S. ARMY WAR COLLEGE, CARLISLE BARRACKS, PA 17013-5050

DTIC QUALITY INSPECTED 4

19990907 071

**Seamless Total Army Recruiting:
A Concept for Army After Next**

LTC Christine T. Marsh
COL Leonard J. Samborowski
COL Jodi S. Tymeson

National Security Program
Discussion Paper Series
99-003

Harvard University

John F. Kennedy School
Of Government

National Security Program

DISTRIBUTION STATEMENT A:
Approved for public release.
Distribution is unlimited.

USAWC RESEARCH PROJECT

**Seamless Total Army Recruiting (STAR):
A Concept for Army After Next**

Prepared by

**LTC Christine T. Marsh
COL Leonard J. Samborowski
COL Jodi S. Tymeson**

**US Army War College
Senior Service College Fellow**

**John F. Kennedy School of Government
Harvard University**

Disclaimer

The views expressed in this paper are those of the authors and do not necessarily reflect the official policy or position of the Department of the Army, Department of Defense, or the U.S. Government.

The views expressed in this paper are those of the authors and do not necessarily reflect the official policy or position of Harvard University, the United States Government, the Department of Defense, the Department of the Army, the United States Army Reserve, or the Army National Guard.

1999 LTC Christine T. Marsh
COL Leonard J. Samborowski
COL Jodi S. Tymeson

For information on ordering this or other National Security Program papers, please inquire of the

National Security Program
John F. Kennedy School of Government
Harvard University
79 John F. Kennedy Street
Cambridge, Massachusetts 02138

TELEPHONE: (617) 496-4980
FAX: (617) 495-8561

Please e-mail your request, if possible to Jean Woodward at:
Jean_woodward@harvard.edu

ABSTRACT

AUTHORS: LTC Christine T. Marsh
COL Leonard J. Samborowski
COL Jodi S. Tymeson

TITLE: Seamless Total Army Recruiting: A Concept for Army After Next

FORMAT: Strategy Research Project

DATE: 1 May 1999 PAGES: 61 CLASSIFICATION: Unclassified

This paper briefly summarizes challenges the recruiting force is facing with the robust economy, changing youth attitudes, American perspectives on military service, and internal inefficiencies when maintaining parallel recruiting structures – United States Army Recruiting Command (USAREC) and Army National Guard (ARNG) Strength Maintenance. The authors suggest a fresh look be taken at how the Army is structured to recruit. Along with a structural change to total Army recruiting, the authors offer operational innovations and improvements for consideration.

A strategy is proposed that advocates the creation of a new Total Army Recruiting Command led by the Army National Guard. The ARNG structure would be the backbone of this command, state staffs would be augmented with other components, and one combined accession mission would be assigned to multi-component recruiting teams; teams trained and able to recruit for all components. Restructuring USAREC, by dissolving five brigade and forty-one battalion staffs, would allow many mid-level leaders to return to active units that are undermanned and stretched thin with a high operational tempo.

Other benefits outlined from a combined program include: resource savings, enhanced integration, better service to prospects, reduced competition, reduced DEP losses, synchronized benefit packages, and increased trust among components.

CONTENTS

Executive Summary	v
Seamless Total Army Recruiting: A Concept for Army After Next	
Chapter 1 Introduction	1
Assumptions	1
Methodology	2
Chapter Specifics	3
Current Situation and Inherent Problems	3
Stating the Obvious	4
The Spiral of Defeat	4
The "So What" Factor	5
Reasons, Rationale, and Other Excuses	6
Three Reasons	6
Robust Economy	7
Changing Culture and Attitudes	8
Conclusion	10
Chapter 2 Strategy	11
Current Situation	11
Recommendations	12
Discussion	12
Total Army Recruiting Command	12
Counterarguments	15
State Employment Guarantees	16
Congressional Tax Breaks for Military Service	16
Conclusion	17
Chapter 3 Structure	18
Total Force Integration	18
Missioning	24
Leadership Responsibility	25

Chapter 4	Operations	26
	Innovations	26
	Reduce AC Delayed Entry Program Losses	26
	Train All Recruiters Together at One Location	27
	Create a Robust Career Path for Recruiters	28
	Emphasize the Vocational Aspect of the ASVAB	28
	Improvements	30
	Stop the Recruiting Competition	30
	Modernize Recruiting Administration	31
	Advertise on the Internet	32
	Use a Contract Telemarketing Firm	33
	Screen the Force for Potential Recruiter Success	34
	Combine Incentive and Enlistment Packages	35
	Share Facilities	35
Chapter 5	Culture	37
	Current Situation	37
	Recommendation	37
	Discussion	37
Chapter 6	Implementation	39
	Current Situation	39
	Recommendation	39
	Discussion	39
	Timeline	39
	A Total Army Recruiter Closes the Sale	41
	Conclusion	43
Endnotes		44
Works Consulted		46

SEAMLESS TOTAL ARMY RECRUITING: A CONCEPT FOR ARMY AFTER NEXT

EXECUTIVE SUMMARY

To best realize efficiencies, conserve resources, enhance integration, and best serve prospects, a change in the current Army recruiting structure should be considered, specifically the formation of a new Total Army Recruiting Command.

Currently, the United States Army Recruiting Command (USAREC) and the Army National Guard (ARNG) conduct separate recruiting programs. This condition is both ineffective and inefficient in a time of limited resources. Maintaining parallel Army recruiting efforts is a detriment to the concept of total Army integration, and most importantly, it handicaps the recruiters in all components in their attempt to provide the force.

In this context, the need arises for the development of an all-inclusive, multi-component recruiting strategy congruent with the Army mission that establishes the norm of a seamless force from entry into the Army, effectively leverages present strengths of both programs, efficiently utilizes resources, and successfully accomplishes the total Army recruiting mission.

Very little has been formally written on the specific topic of total Army recruiting. However, a wide variety of resources were tapped, and foremost in value were recommendations from the recruiting force.

RECOMMENDATIONS:

❖ **Create a new Total Army Recruiting Command using the ARNG structure.**

The ARNG recruiting system is less management manpower intensive, is focused on long-term strength maintenance, develops stable relationships with centers of influence, is community-based, and currently has a recruiter production rate nearly twice that of USAREC.

❖ **Share the combined recruiting mission by geographical area.**

Recruiters should be trained together and expected to enlist soldiers into all three components. The overall mission would be divided into geographical areas within each state.

❖ **Increase AC leadership involvement in recruiting accountability.**

Leaders should become involved with local recruiters and increase opportunities for their soldiers to become involved in the recruiting effort. All soldiers in units should actively seek leads for recruiters in their geographical area and encourage every young person to talk to an Army recruiter.

❖ **The National Guard should take charge of the AC Delayed Entry Program (DEP) soldiers.**

New DEP soldiers should be placed in ARNG units to receive support and training in preparation for basic training. The AC should transfer funds to allow these soldiers to be paid while attending drills.

❖ **Share facilities to save money, enhance integration, and better serve the prospects.**

Storefront rentals should be multi-component, and those without significant walk-in traffic should be eliminated. All recruiters could share ARNG armories or reserve centers to save rental money. Sharing facilities would improve recruiter networking.

❖ **Synchronize incentive packages and enlistment bonuses.**

Recruiters should be able to offer all three component packages, and the Army should consider combining service options. For example, a soldier serves for 2 years on active duty to become MOS qualified, and then he serves four years minimum in a reserve component to qualify for college tuition benefits.

❖ **Reach beyond the Army and work with states to provide employment guarantees with partnership bonds to private industry.**

State government and private industry should be encouraged to offer programs that guarantee jobs upon completion of active duty service. Work should be done on certification programs that would allow transfer of military skills to civilian jobs.

❖ **Reach beyond the Army and champion tax incentives for those individuals and institutions that have the most influence on soldiers.**

Devising a tax break system rewarding all influencers of youth would get a higher percentage of the American population involved in encouraging military service. Soldiers, parents, high schools, and colleges would be the major benefactors.

❖ **Implement operational innovations and improvements:**

- Rename the ASVAB to VAT and encourage the Department of Education to mandate the administration of a VAT to all high school sophomores to improve upon vocational counseling.
- Modernize recruiting administration, and aggressively use the Internet as a tool.
- Contract a telemarketing firm for initial prospecting.
- Screen the force for potentially successful recruiters.

In an era of limited resources and the desire for total Army integration, this concept of seamless recruiting should be considered. A major structural change could accomplish the realization of efficiencies, reduce component competition and increase production, better serve the prospects, and lead to an integrated Army. America's Army must maintain its personnel readiness to be able to fight and win the Nation's wars. We must fill spaces with quality faces because SOLDIERS ARE THE ARMY.

Chapter 1 – INTRODUCTION

This paper is about Army recruiting and has been organized into six chapters. First, we establish a baseline description of the current state of the Army's recruiting effort and explain the problems inherent in that system.

In the second chapter, through the template of the Mintzberg Model we recommend strategy, structure, and operational changes to fix those problems identified in Chapter One.¹ These short and long-term actions are the heart of this paper and make up Chapters Two through Four.

In Chapter Five we describe the likely cultural changes that can be expected from the implementation of our recommendations.

Finally, the paper is summarized in Chapter Six via a scenario that describes the viability of our plan in terms of a proposed timeline and narrative.

ASSUMPTIONS:

This paper addresses only one of the components of Army personnel (strength) management - recruitment. The manpower issues of attrition (loss of soldiers from the training base) and problems in the retention (reenlistment of soldiers who complete their initial tour of military duty) are recognized as significant contributors to the state of Army force structure, but are beyond the scope of this paper.

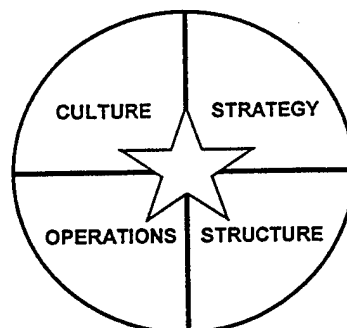

Figure 1

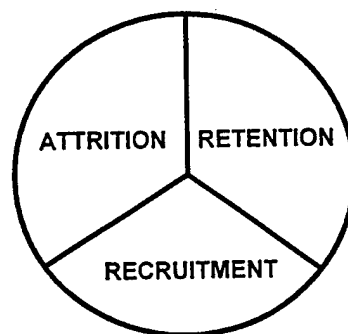

Figure 2

An important assumption of this paper is that the much-talked about and often debated restoration of the draft will NOT occur. Implementation of a draft or a national service obligation would probably solve the Army's current recruitment problems (as it created other problems), but the authors of this paper do not see such an initiative as being politically palatable in our current culture.

METHODOLOGY:

A wide variety of resources were tapped in the research of this paper. Foremost in value were recommendations from the recruiting force. This input was assembled from telephone calls, face-to-face interviews and e-mails with recruiters from the three components of the United States Army (AC, USAR and ARNG). The authors of this work believe the scope of our contacts are representative of the force.

Specifically, the following organizations were reached in the development of data for this paper:

- The United States Army Recruiting Command Headquarters (USAREC), Fort Knox, Kentucky
- Five of five recruiting brigade headquarters².
- 41 of 41 battalion headquarters
- 36 individual recruiting stations³

Within these organizations, several key offices were questioned for details. These contacts include: the Commander of the 2nd Recruiting Brigade and the Command Sergeant Major (1st Brigade) for their thoughts about the disadvantages of recruiting with the Army National Guard, the Budgeting Offices (1st and 2nd Brigades) for an understanding of resource issues at the recruiting brigade level, the battalion executive officer of the Portland Recruiting Battalion (6th Brigade) for information about recruiter morale problems, and the supply office of the Harrisburg Recruiting Battalion (1st Brigade) for particulars on individual recruiter supply issues.

The Internet proved to be a rich source of information about military recruiting. Most helpful in this research were the Army Times and the Military City Online (MCO) homepages. These two Web sites yielded over 200 pages of articles that were culled through to validate or disprove the premises of this paper.⁴

Additionally, military briefings from the company to the USAREC command level were helpful in providing the details about recruiting production trends and future projections. Of special note were the detailed briefings provided by the Harrisburg, Des Moines and Phoenix Recruiting Battalions and the homepages of the Sacramento Battalion and USAREC Headquarters.

Finally, published papers on the issue of military recruiting were reviewed. Although several published works addressed the prospect of joint service recruiting, no publications were found on the main theme of this paper.

Chapter Specifics

Chapter One was heavily endnoted with articles found in online searches of the Army Times and MCO. These Internet articles were the most timely sources of current Army recruiting problems. Chapter One was also strongly supported by a March visit by one of the authors of this paper to USAREC Headquarters. During the co-author's tour of Fort Knox he was able to talk directly with the Director of Program Analysis and Evaluation, the Advertisement and Public Affairs Office, the Office of Demographics Analysis and the USAREC Command Inspector General. The personal interviews of these key personnel yielded the majority of the statistics and rationale cited in Chapter One.

Chapter Four was primarily supported by numerous conversations and e-mail traffic with field recruiters. Unfortunately, less than 10% of the e-mail was returned with comment. A second source of reference for this chapter was the publications and regulations of the Recruiting Command. These regulations prescribe the current mechanics of Army recruiting and are therefore crucial to understanding the present command methodology.⁵

CURRENT SITUATION AND INHERENT PROBLEMS:

The system is broken, and we know it. If current trends continue, and there is no event on the horizon that portends otherwise, FY99 will mark the second year in a row that the United States Army fails to meet its recruiting accession goals. Indeed, as of March 1999, the United States Army predicts a 10,000-soldier shortfall for the Active Component (AC) recruiting mission and a similar shortage for the United States Army Reserve (USAR).⁶

These manpower insufficiencies rightfully concern senior army leaders. General Dennis Reimer, the Army Chief of Staff, views today's recruiting problems as tomorrow's operational readiness issues.⁷ His commanders in the field agree. "We reached a point (in 1997) where

squads could not function because ... of shortages," says Major General Simpson, the recently retired commander of Army forces in Alaska.⁸

Other senior leaders tell similar stories of severe shortages of tankers, canoneers, cavalry scouts and air defense crewmen. Yet the shortages are not confined to combat arms jobs. In FY98, recruits for the Military Occupational Skill (MOS) of an electronic warfare linguist were nearly 2,000 less than the required quota.⁹

Stating the Obvious

A look at the graphic below illustrates the Army Recruiting production trends (in thousands by fiscal year) over the last 12 years.

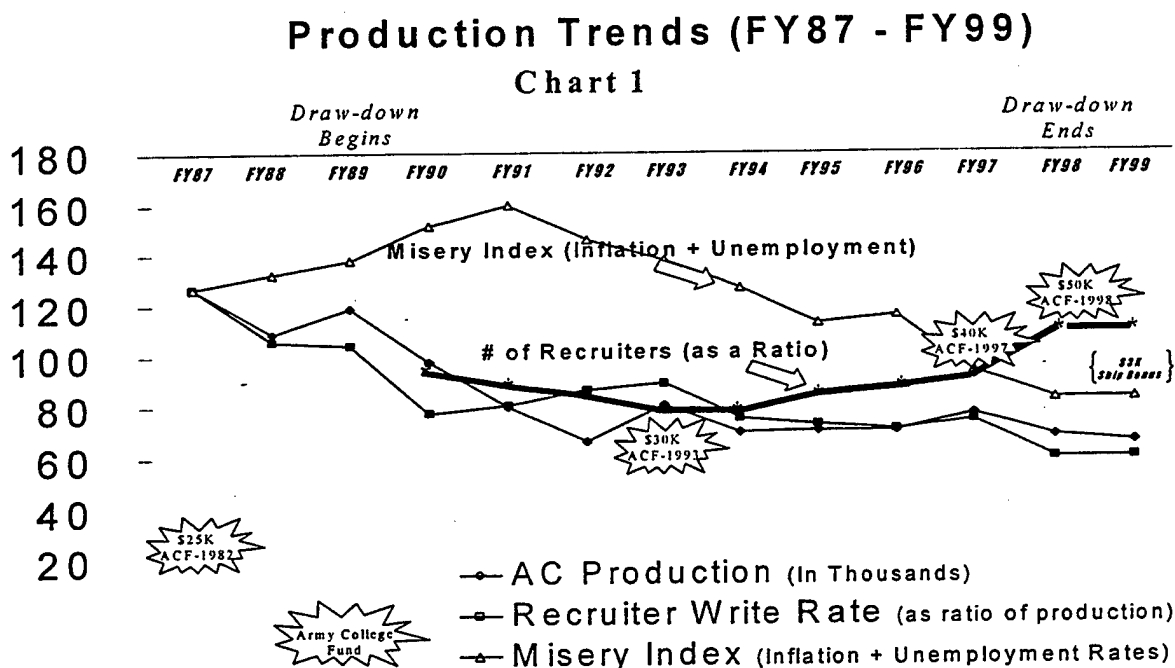

The Spiral of Defeat

Since 1989, AC production is down 43%. In 1997, the BEST battalion in USAREC in terms of production, the Miami Recruiting Battalion, achieved only 79% of its AC mission against the USAREC average of 57.8%. A year later, Sacramento, the BEST battalion in the command, made 69.4% of a similar mission, while USAREC remained at 57.8%.¹⁰ The Army is in severe trouble if the best battalion in the Recruiting Command can only achieve 75% of its mission.

Most troubling is the failure of increased resources, in the form of manpower and monetary incentives, to reverse downward production trends. Adding more recruiters to the recruiting effort has not increased Army enlistments and may be hurting the readiness of the service. During the last 5 years, "Can Do" Army leaders, recognizing the power of professional noncommissioned officers (NCO), have increased the recruiting force by 131%.¹¹ The argument is that more recruiters equate to more recruits. Because these NCOs have to be sharp, articulate professionals to succeed as recruiters, only the best NCOs are taken from the available resources in the AC and USAR force and assigned to USAREC. Consequently, Army field units often suffer as they sacrifice some of their top NCO trainers and mid-level leadership in an attempt to help the recruitment mission.¹²

When increased manpower alone fails to fix the problem, money is often added into the equation. As Chart 1 shows, the Army College Fund was increased from \$25,000 in 1982 to \$50,000 in 1998 without a significant upturn in production. Additionally, throwing money at the problem further compounds the Army's situation because of the zero sum game of the budgeting process. Money that goes into the recruiting coffers must always be taken from other areas of the Army budget.

Bottom line: Since 1987, despite an increase in NCOs in USAREC and despite an increase in the recruiting budget, the Army recruiting system is failing to "Provide the Force." This failure would be catastrophic without the artificial buffer provided by the concurrent Army personnel cuts.

Beginning in 1987, the Army reduced its force structure, shrinking from 780,000 to 480,000 by 1997. As a part of these reductions, the Army allowed a commensurate reduction in its recruiting goals allowing USAREC to artificially make mission. As stated by MG Mark Hamilton, former Commanding General of USAREC (1997), "In effect, PERSCOM has written us a 'blank check' for 30,000 [soldiers] per year for the last 10 years as we have drawn down. Now we are out of checks."¹³

The So What Factor

The number of recruits is down and getting worse. That is obvious from even the most superficial analysis of production trends. Reporting the bad is easy. A more challenging aspect of a production analysis is to understand the probable reasons why recruitment is down. Finally, the critical piece of any analysis is to recommend corrective actions to fix the problem.

Reasons, Rationale and Other Excuses

There are several reasons why the Army is not meeting its recruitment mission, but people, talent and available resources are not among those factors.

First, the manpower and quality issue. USAREC is not people poor. The command claims almost 6,000 NCOs in the towns and cities of America, with a supporting staff of 2,040, all focused on the mission of selling the Army.¹⁴ The majority of these personnel are top notch. Indeed, USAREC often boasts that it has some of the finest officers and most dedicated non-commissioned officers (NCOs) in the Army, all of them working long hours to provide the force.¹⁵

Secondly, recruiting resources appear to be sufficient. USAREC offers adequate office space, computers and telephones to meet the work requirements. Additionally, all recruiters in the command have access to Government Service Agency (GSA) vehicles and a government gas credit card to keep them mobile. (In FY99, the GSA vehicles programmed budgets for the 1st and 2nd Recruiting Brigades, two of the five brigades in the command, were \$6.4 and \$6.1 million, respectively.)¹⁶

The important resource of money doesn't seem to be an impediment to production. In 1998 the Army spent well over \$11,000 per recruit to bring young Americans into the service, the highest of any of the Armed Services.¹⁷ Add to this figure an advertising and public affairs budget of \$99M, and it seems as if there are enough funds in the Recruiting Command's budget to support the recruiting force.¹⁸

Three Reasons

If we contend that USAREC has enough money, resources and quality people to get the job done - what then is the problem? Why isn't the Recruiting Command making mission?

There are three reasons why:

1. A robust national economy.
2. A changing American culture and attitudes.
3. USAREC inefficiencies (addressed in Chapter 4).

Almost all of the detailed explanations for the current recruiting downturn can be understood from the perspective of these three broad reasons.

1. Robust Economy

A review of Chart 1 points out an apparent positive correlation between reductions in Army enlistments and the reduction of the country's "Misery Index" (a combination of the unemployment and inflation rates). In fact, the correlation seems to be linear. Seemingly, a good economy is bad news for Army recruiters.

In 1997, the American unemployment rate dipped below the 5% threshold (4.3% as of December 1998).¹⁹ This unemployment rate, coupled with low inflation rates (the best in 40 years) has resulted in "feel good" economic conditions in America. Fewer young Americans seem inclined to join the Army when other, less physically demanding occupations are available that provide equal or greater pay and benefits.²⁰

Compounding the effects of a strong economy is the perception of eroding military benefits, which Army general officers are aggressively addressing. Three obvious examples are:

- (a) A Pay Gap - The Department of Defense estimates a 13% pay differential between soldiers and their civilian counterparts.²¹
- (b) Military Retirement - Prior to 1986, enlistees received 50% of their base pay upon retirement after 20 years of service. After 1986, a new system called "REDUX" was put into effect. This system gave the retiree only 40% of the base pay after 20 years.²² Many new soldiers dislike Redux.
- (c) Medical Care - An ongoing transition (started in 1995) to TRICARE (an HMO concept) has been rife with service and support problems. Many soldiers and their families feel that the Army's promise of full medical care has been broken.

The robust national economy has increased competition from the civilian job market. Civilian corporations now actively recruit against Army recruiters in a fight over the potential labor force of America. A byproduct of this situation is that many businesses now offer educational aid to their employees as a job incentive.

The final competitor is the Army's own National Guard (ARNG) units. Many state National Guard programs offer college tuition assistance packages. In fact, 14 states offer 100% college tuition programs, while 32 state Guard programs provide partial college assistance. Such competition, which could be viewed by a skeptic as a direct assault on the goal of a seamless Army, is but one more challenge to the Total Army recruiting effort.

2. Changing Culture And Attitudes

American culture is different today than it was in June of 1973, when the current recruiting system was created along with the establishment of the Army's all-volunteer force. This cultural shift is significant, must be acknowledged and accommodated, if the Army hopes to experience success and not further mission frustration and failure.

Four current conditions suggest a change in America's attitude toward the Army. These conditions are: a lack of military experience among our government leaders, shrinkage of the prime market, high attrition rates for recruits, and a decreased propensity to enlist in the military.

(a) Lack of Military Experience - Limited military experience in Congress (Chart 2) implies an absence of military advocates among our civilian leadership and necessitates a continuous need for the Army to educate our government leaders about the challenges of military service.²³

Lack of military service concerns some government leaders and scholars. Charles C. Moskos, a professor of Sociology at Northwestern University states, "... if you never served you become either hostile or obsequious to the military."²⁴ Senator John McCain (Republican - Arizona), adds to Moskos's concern, "... we are raising a generation of not only leaders but middle-income Americans who have never served their country."²⁵

Military Experience
Chart 2

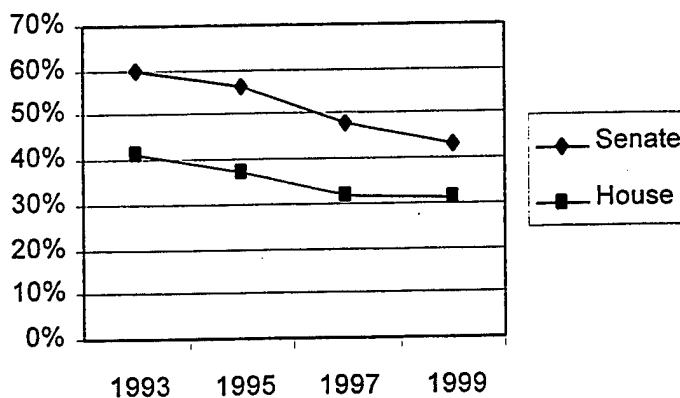

b) Smaller Market - The prime market from which to draw recruits has shrunk. Only 14 % or 1.4 million males (ages 17-21) in America are qualified to enlist,²⁶ 23 % are medically or morally disqualified and 41% fail to meet the mental or educational requirements. (See Chart 3).²⁷

The problem of this smaller market is further reflected in the contact to contract ratio. The Recruiting School at Fort Jackson teaches that it takes approximately 140 contacts to achieve one enlistment contract. With an AC mission of 74,500 new recruits in FY99, at a 140:1 ratio, this requires 10.4 million contacts to meet the Army's mission.²⁸ Yet the recruiters look for our new soldiers in a pool of about 1.4 million males.

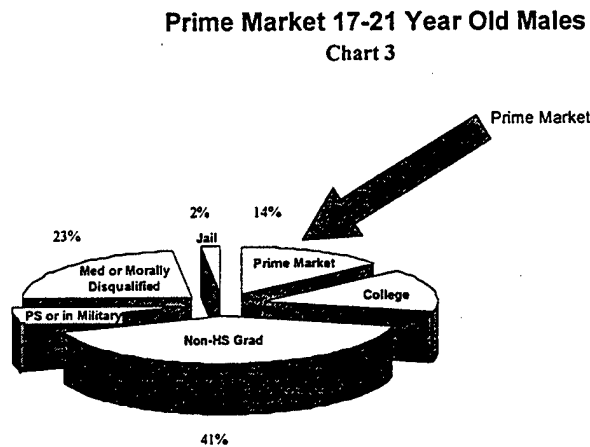

The impact of this reduced prime market is that in order for the Army to meet its FY99 mission it must recruit eight out of every 100 eligible youths and take 4 out of every 10 contracts that are written by the Department of Defense.²⁹

(c) Attrition Up/Propensity

Down - Attrition is the loss of new Army recruits from the training base. Over the last 5 years, normal basic training losses have run about 20%. In FY98 this attrition rate increased dramatically to 32%. The bad news is that FY99 looks no better. As of January 1999 the attrition rate is 30%. As more and more new soldiers drop

PROPNESITY TO ENLIST IN ARMY

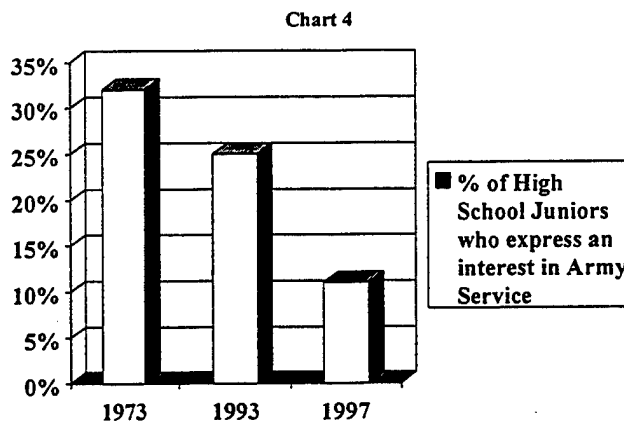

out, fewer and fewer young people seem interested in taking their places. Indeed, the propensity to enlist in the Army has been in steady decline since the end of conscription (Chart 4).³⁰

An underlying current in the discrediting of Army service is the ignorance among many of the social influencers of young Americans. Many parents, relatives, coaches, teachers and friends of potential recruits discount the Army option simply because they don't know the details about military service. As already implied in Chart 2, less and less of the American leadership

and population have direct military experience. Consequently, misperceptions about the military are understandable byproducts of this non-service generation. In some cases, they don't want to know, being content with their vacuum based perception about the Army. The result to the Army is that the recruiter must fight an uphill battle against a significant emotional supporter as they try to enlist the young person into the military.

CONCLUSION:

Taken in sum, the conditions described above create an environment that is non-conducive and, in some cases, openly hostile to the recruitment effort. Within such an environment it is crucial that:

- a. The Army's recruitment strategy is congruent with the Army's mission.
- b. The recruiting command structure is compatible with a changed American culture.
- c. The day-to-day recruiting operations are optimized to provide the greatest chance for success.

Finally, it is recognized that implementing a new Army recruitment strategy, with its resultant structural and operational changes will affect the culture of Army recruiting.

Chapter 2 - STRATEGY

Here's the way to avoid taking action on a problem. First, reject the problem and its solutions intellectually, saying that they won't work. Second, attempt to force the problem into existing processes in a mechanical way. Third, slice it up into pieces and allow people's natural tendencies for territorial assertion to take over.

Senior Executive, Southern Insurance³¹

Strategy is an intellectual construct linking where you are today with where you want to be tomorrow in a substantive, concrete manner.³² As Chapter 1 described, we are not where we need to be today in the process of recruiting for the Army of tomorrow. Consequently, we need to decide what construct will move us toward where we want to be. This construct cannot be more of the same from today and yesterday. The restructuring of Army recruiting must involve the design and construction of new patterns, and a reconceptualization of old operational techniques if there is any hope for increasing recruiting production.³³ We have already tried adding more resources to try to affect change (better production). We have attempted to refocus advertising to try to affect change (better market influence). It is time to stop nudging against the edges of old patterns. We must reshape our way of doing business. This chapter outlines a basic strategy for change in an approach that calls for total Army recruiting, encompassing all three components (AC, USAR, and ARNG).

CURRENT SITUATION:

Currently, USAREC (AC/USAR) and ARNG conduct separate recruiting programs. This condition is both ineffective and inefficient with much redundant energy wasted in a time of constricting resources. The current situation does not encourage integration; in fact, it contributes to competition and misperceptions among the components. In short, maintaining parallel Army recruiting efforts is a detriment to the concept of total Army integration, and most importantly, it handicaps the recruiters in all components in their attempt to provide the force to the United States Army.

There is good news. Both recruiting programs have unique strengths in their operations, beginning with the high quality of noncommissioned officers. Additionally, most senior Army leaders understand the criticality of personnel readiness and the need for true seamless integration of the three Army components. According to General Reimer, "We must take a

holistic view toward active and reserve component recruiting, training, and retention and avoid optimizing one component without realizing the impacts on the others.”³⁴

In this context, the need arises for the development of an all-inclusive, multi-component recruiting strategy congruent with the Army mission that:

- establishes the norm of a seamless force from the first steps of entry into the Army
- effectively leverages the present strengths of existing programs
- efficiently utilizes resources
- successfully accomplishes the total Army recruiting mission.

The Army has focused most of its monetary efforts on soldier enticements, such as bonuses and college funds, but are still falling short on enlistments. Maybe other avenues should be pursued.

Some options to consider include: 1) Do nothing and be content with the status quo, 2) return to conscription, 3) increase the advertising budget or change the advertising strategy, 4) change the incentive packages, 5) privatize recruiting functions, and 6) restructure the system to leverage existing strengths and realize efficiencies.

RECOMMENDATIONS: 1. Create a total Army recruiting command and put the ARNG in charge. 2. Provide state employment guarantees with partnership bonds to private industry. 3. Champion Congressional tax breaks for those individuals and institutions who have the most influence on soldiers.

DISCUSSION:

1. Total Army Recruiting Command

A Total Army Recruiting Command should be formed and managed by the ARNG. This is a mission perfectly suited to the way the ARNG is structured for recruiting. Chapter 3 will discuss in detail this new command structure, but the advantages to such a system are many.

The ARNG currently has a recruiting system that is less manpower intensive than USAREC. Only 38 soldiers work at the national level in the strength maintenance operation, while each state is managed with one Recruiting/Retention Manager (RRM), two sergeants major (E9s), and a small support staff. The recruiters are supervised by NCOs. Commanders have responsibility in the system, but very few other officers are in the chain of command for recruiting management.

The ARNG is focused on long-term strength maintenance. In fact, ARNG recruiters are actually titled Strength Maintenance NCOs. The ARNG recruiters have good relationships with

their local centers of influence, and some recruit in or near their hometown. The ARNG is a community-based organization, and the structure provides for long-term stability.

ARNG strength maintenance NCOs have a production rate that is nearly twice that of USAREC with only one-third as many recruiting personnel. This is an efficient way to do business.

A Total Army Recruiting Command will be created using existing strengths of current programs, using the ARNG organizational chart, will have one accession mission, feature recruiters working together, and will be consistent with the current USAREC vision and transformation strategy.

This command will initially be led by an ARNG Major General, assisted by one AC and one USAR Brigadier General. The Commanding General and Deputy Commanding General positions could be rotated between the components. The decentralized execution will be through the ARNG strength maintenance structure – a structure already in place and working. The staff of this command will be multicomponent but work through one chain of command.

The current structure of USAREC will be altered. Many middle managers -majors, captains, senior NCOS - will be returned to the active component where there is a critical need for their skills. The ARNG state strength readiness staffs will be augmented with minimal but essential members from other components to help support the total Army recruiters; all recruiters will be total Army recruiters. These recruiters will be supervised by NCOICs who have been successful recruiters themselves. Adjutants General will be charged with the responsibility for the supervision and mission success of the total Army recruiting force in their state. This new strategy will lead to a more community-based recruiting effort. Chapter 3 provides more detail on structural transformation and a new organizational design.

Assignment of one realistic and properly resourced accession mission that includes the needs of all components will be presented to the Commander of the Recruiting Command. This mission must have component leadership concurrence (AC, USAR, and ARNG). The 54 Adjutants General and their staffs will execute the mission. Success will be defined by the achievement of ALL component requirements.

Recruiters will work together with shared geographical area missions, and all will be trained and expected to write contracts for every component. This new method will reduce competition between components, enhance integration, and most importantly, better serve the

prospects. Soldiers entering the Army will witness an integrated force from day one of their career through a recruiting system that typifies the seamless Army. A recruiter able to offer the full range of options for three components (currently not within the recruiter's realm) certainly has an improved opportunity for increased production.

The approach outlined in this paper for a new recruiting command is consistent with several comments in the USAREC Vision and Transformation Strategy, November 1998, such as:

1. "We must change the practices that are grossly inefficient or have become outdated, continue with values that have brought historic success, and grow in new directions that lead to long-term success." **The proposed total Army recruiting command structure reduces redundancies, saves resources, and enhances integration.**
2. "We must modify the sales doctrine and process to sell the products of the Army." **Combining marketing analysis and national advertising while allocating resources for local advertising helps to accomplish this.**
3. "The recruiting system must change to allow more information and choice for the prospect earlier in the sales process." **The recruiter will be able to offer all three component benefit packages.**
4. "The command must stabilize leaders from the CEO down to the professional salesman level." **The ARNG structure, augmented with other components, will provide this needed stability.**
5. "Fundamental change is required in manning levels, positioning decisions, and management structure, as well as the processes that determine these requirements." **The proposed total Army recruiting command will provide fundamental change. The manning levels will be reduced and integrated, positioning decisions will be based on current demographics, and the management structure will be based on the ARNG organizational chart. (Addressed in Chapter 3.)**
6. "The recruiting system requires a top-to-bottom functional process review. The review should focus on two competing perspectives: savings and system enhancement".

A detailed spreadsheet that would show resource savings with this new approach is beyond the scope of this paper. Combined market analysis and advertising functions would save

overhead and manpower costs. Sharing facilities is smart business. Returning leaders to the field Army has a benefit beyond dollar measurement.

Counterarguments

There are many who doubt the probabilities for success of total Army recruiting. Their comments include: " We've never done it that way. The Constitution won't allow it. The law won't allow it. We can't work together. We are too set in our ways. ARNG recruiters are trained as 79T, whereas AC / USAR are 79R / 79S. We'll lose our identity as a component."

The Army leadership is key to overcoming these parochial mindsets. We are in a new age of market forces concerning American youth. We have never been as committed to integration as we are now. Training is an Army strength; new ways of doing business can be trained. The Constitution speaks to raising armies and the militia, but it does not restrict us from working together. There are no laws prohibiting cooperation and shared innovation. We have integrated divisions, and initiatives continue in many other areas. The integrated recruiting program will not affect the fact that the AC will be sent to Kosovo tomorrow and the ARNG will be called to duty for next week's flood.

As you will see, this paper does not propose component changes; it proposes a combined recruiting effort with a recruiting command structural realignment, adjustment of resources, and most importantly – the use of strengths already in place. To make the integrated program most effective, and to improve overall personnel readiness figures, the emphasis on recruiting and retention efforts for the total Army is obvious. More soldiers retained means a smaller accession requirement.

Every leader in the Army will be responsible for contributing to the success of the Army's personnel readiness. This view is consistent with the November 1998 USAREC Vision and Transformation Strategy that states, " The entire United States Army must become an active part of the recruiting system. The Army must develop a mentality that all green-suiters are recruiters; all commanders are recruiter supporters." The recruiting chain of command will monitor numerical progress toward goals. Every soldier must understand his or her responsibility to help recruiters (and retainers) meet the mission. Many ARNG units currently require soldiers to provide leads to recruiters (this effort is positively rewarded), hold recruiters responsible for writing contracts, and ensure commanders at all levels are accountable for

positive encouragement and support to the strength readiness mission. We should consider the ability to provide a lead to the local recruiter as an additional common soldier task.

2. State Employment Guarantees

To reach beyond the Army itself, secure each state's involvement in Army contracts that would guarantee jobs within the state upon release from active duty. The Army, through the Guard component, could work with each state's business and government leadership to encourage programs that will guarantee jobs in the soldier's home state upon completion of contracted time in the Army. Establish partnerships with business to develop a total life cycle commitment of service from enlistment to training to military experience to civilian career that supports the military through contracted work. Since the military is outsourcing, perishable skills like computer specialist and linguists could be grown through outsourcing partnerships. In consort with this, the Army should create a certification program for skills learned in the military that can be translated into civilian skills recognized by the states and future employers. Along with this, push a program for ex-soldiers to become school counselors, not just teachers. This would help ensure that students are exposed favorably to the military as a successful career path and that the military is presented as a viable career option to the students of America.

3. Congressional Tax Breaks For Military Service

Politically, there is much debate on potential financial options to fix the recruiting problem. The key is to get everyone involved in recruiting citizens into military services. All individuals, schools and institutions that most influence youths must see a benefit for them in recruiting for the military. Devising a tax break system that will reward all influencers is a Win-Win situation. The following is an example of such an initiative that could promote interest in serving in the military:

- a. Parents receive a \$1000 tax break for every child serving in the military.
- b. Soldiers in grades E1-E5 receive a 10% tax break while serving in the military and a 5% tax break after they leave service for each year they served in the military. For example, an E4 enlists for six years and gets a 10% tax break for those six years. Once he completes his enlistment, he will then receive a 5% tax break for the next six years.
- c. Soldiers in grades E6-7 and O1-4 receive a tax break of 5% while they are in service and after they leave service receive a 5% tax break for the same number of years served.
- d. Soldiers in grades E8-9 and O5-10 receive a tax break of 5% while they are in service.

- e. High schools and colleges would receive a \$3,000 and \$5,000 grant or federal aid award respectively upon successful first term enlistment completion for each student that they assist into military service.

These programs will encourage active support to military service. These tax breaks will put more money into the hands of individuals and yet cost nothing to the Army. Also tax breaks will not require an increase in the budget. A definite Win – Win situation!

CONCLUSION:

Many interviews with all ranks throughout the Army have shown a positive willingness to work together and a need for a new way of approaching the critical mission of recruiting new soldiers.

The strategy visualized in this chapter is a macro view of a new recruiting system for the total Army. This concept is only one approach to an integrated program, but this method gives heavy consideration to successful structures in place and puts full trust and confidence in the leadership and soldiers to execute together. While under no delusions that the authors of this paper are prime movers, we do believe in its prospects for success. What do we have to lose?

It is easy to propose a grand strategy; it is quite another task to implement it. The following chapters will further define the structural transformation of this strategy, the more detailed operational changes, the cultural byproducts that may be expected, and will outline a possible timeline to help visualize the pathway to Seamless Total Army Recruiting (STAR).

Chapter 3 – STRUCTURE

Changes take hold when they are reflected in multiple concrete manifestations throughout the organization. After all, people's behavior in organizations is shaped by their place in structures and by the patterns those structures imply.³⁵

The Change Masters

The current recruiting command structure must change to be compatible with a changing American culture. Current literature on analyzing successful organizational change states structural modification is essential to successful transformation. This chapter will outline a proposed structural design for STAR.

1. Total Force Integration.

CURRENT SITUATION: In the past few years the Office of the Secretary of Defense (OSD) has consistently worked to break down bureaucratic and operational barriers among the three components. As stated in the Annual Report to the President and the Congress, "Progress towards Total Force integration depends on the ability of all military and civilian leaders to create an environment that eliminates residual barriers to integration – structural and cultural."³⁶ Some barriers among the three components are artificially created by lack of knowledge about each other's strengths, capabilities and procedures. Education through close association is the key to breaking down doors of unfamiliarity with processes and policies. The more the AC works with the RC, the more appreciation, confidence and trust develops among the soldiers. To achieve this camaraderie through situational osmosis, the Army has undertaken several initiatives, combining elements of each component to create integrated units.

If the Army can integrate major units, as shown in the chart on page 19, with complicated operational coordination requirements, the Army should integrate USAREC and ARNG recruiters with a single focus to begin integration at the beginning of a soldier's career. According to Chief of Staff of the Army (CSA), integration is about a quality force, not about how Reserve component units can supplement or replace Active units. It's creating what the Nation needs by blending all three components to ensure the best mix of forces available to get the job done.³⁷

MULTI-COMPONENT UNITS BY FY 00

Force Programs Directorate, Office of the Deputy Chief of Staff for Operations and Plans, U.S. Army³⁸

AC flag ARNG elements	AC flag USAR elements:	ARNG flag with AC element	USAR flag with AC elements	Tri- component:
1-159 CMD AVN BN = AC HHC(NC) and 2 AC companies & 3 ARNG companies(SC, NC, MS)	122 MP DET Prisoner of War Information Center (PWIC)(NC) = AC with USAR filler personnel	142 SIG BDE = ARNG HQ(AL) with two AC cells (WA, AL)	304 Corps Material Management Center = USAR HQ (CA) with AC cells (WA,CA)	Army Service Component Command (ASCC) South (Puerto Rico) = AC HQ with USAR and ARNG filler personnel
46 EN BN = AC HHC(LA) and 2 AC companies(LA, AL) & ARNG company(TN)	673 DENTAL CO(WA) = AC company with USAR filler personnel	1-171 CBT SPT AVN BN = ARNG HHC (GA), 3 ARNG companies (GA, FL) & 3 AC companies (NC)	3 Medical Command (GA) = USAR HQ with AC filler personnel	52 EN BN = AC HHC (CO), 1 AC company (CO), 1 ARNG company(OR), & 1 USAR company (NM)
32 Army Air & Missile Defense Command = AC HQ(TX) with ARNG filler personnel				93 SIG BDE (GA) = AC HQ (GA) with USAR and ARNG filler personnel

Currently, there are two separate and distinct recruiting structures and philosophies competing against each other for limited resources. The first run by the AC with USAR participation which is USAREC, and the second run by the ARNG which is ARNG Strength Management. USAREC is headquartered at Ft. Knox, Kentucky, with a cadre of approximately 68 AC and 60 USAR soldiers, performing statistical analysis, advertising, public relations and other support functions. Within USAREC there is a large command and control infrastructure reflected in the diagram below to manage the recruiters within the community.

USAREC STRUCTURE

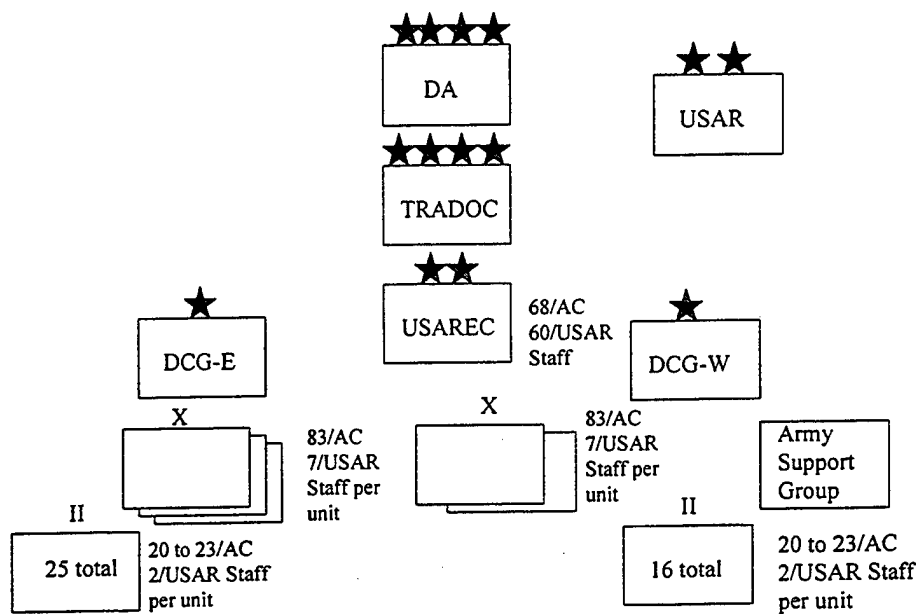

Note the approximate number of staff positions in the 5 Brigades (X) and 41 Battalions (II) dedicated to supporting recruiters. Also look at the command hierarchy above, with USAREC reporting to Training and Doctrine Command (TRADOC). As stated in Chapter 1, personnel management deals with a triad of functions: recruiting, retention and attrition. Taking one of the strength management functions out of the personnel chain seems to add another layer of administration and bureaucracy that must be maneuvered through to get the job done.

The ARNG recruiting effort is located at National Guard Bureau (NGB), Arlington, Virginia and executes the same support functions as USAREC, only with 38 people. Within NGB ARNG Strength Management has a small command and control infrastructure located in

each state and territory (a total of 54) reflected in the diagram below to manage the recruiters within the community.

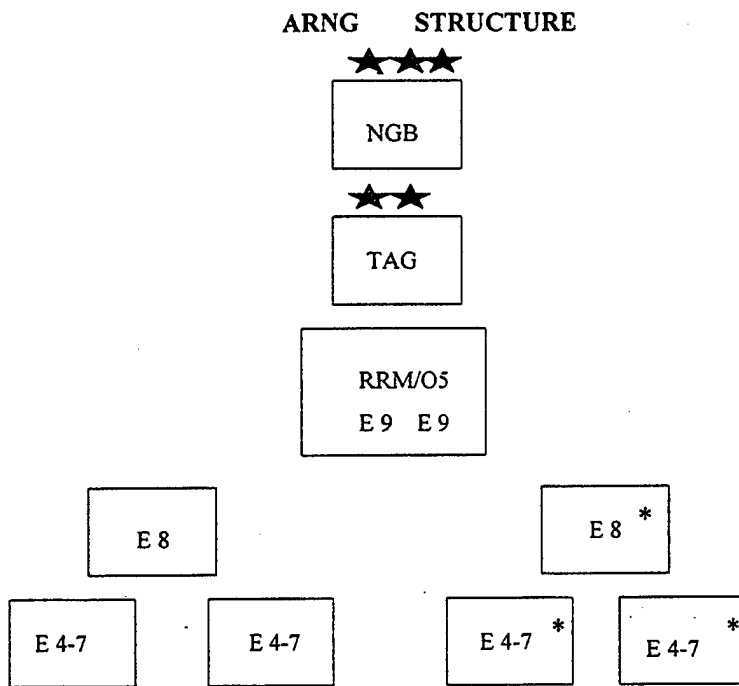

* Numbers vary according to state size

Most states are uniform in their organizational structure of the Recruiting and Retention Force. Each state has a Recruiting and Retention Manager (RRM) - Lieutenant Colonel/O5, two Sergeants Major/E 9s, several area NCOs/E 8s (the number depends on the size and population of the state) who are responsible for between 6 and 8 R&R NCOs/E 4 to 7s. The supporting staff of the RRM consists of 1 to 2 marketing NCOs, 1 training NCO, 1 supply sergeant, 1 to 2 clerks, and an operations officer (rank varies from Major/O4 to Warrant Officer) responsible for the budget and manning documents. Larger states will have officers that oversee the area NCOs and are spread out demographically throughout the State.

RECOMMENDATION: Totally integrate the recruiting command by putting the ARNG in charge of executing the total Army mission; thereby streamlining management by eliminating many administrative layers and commands, while downsizing the AC component at USAREC.

DISCUSSION: Totally integrate the headquarters recruiting staff so each of the three components shares representation. Put the Guard in charge of overseeing the total Army recruiting effort within the community and do away with the USAREC brigade and battalion structure of today. Go straight to the states and territories for mission execution, under the

direction of The Adjutants General (TAGs). The TAGs will be charged with the responsibility for the supervision and mission success of the Total Army Recruiting force in their state. This realignment will eliminate two layers of administrative overhead (5 brigades and 41 battalions), in order to increase efficiencies. Many middle managers – majors, captains, and senior NCOs – will be returned to the AC, reinvested into field units where they are sorely needed, streamlining the entire management structure. Below is a comparison of both current structures with perceived force structure savings Xed out of the AC force that could be reinvested into AC field units.

POTENTIAL STAFF POSITION SAVINGS

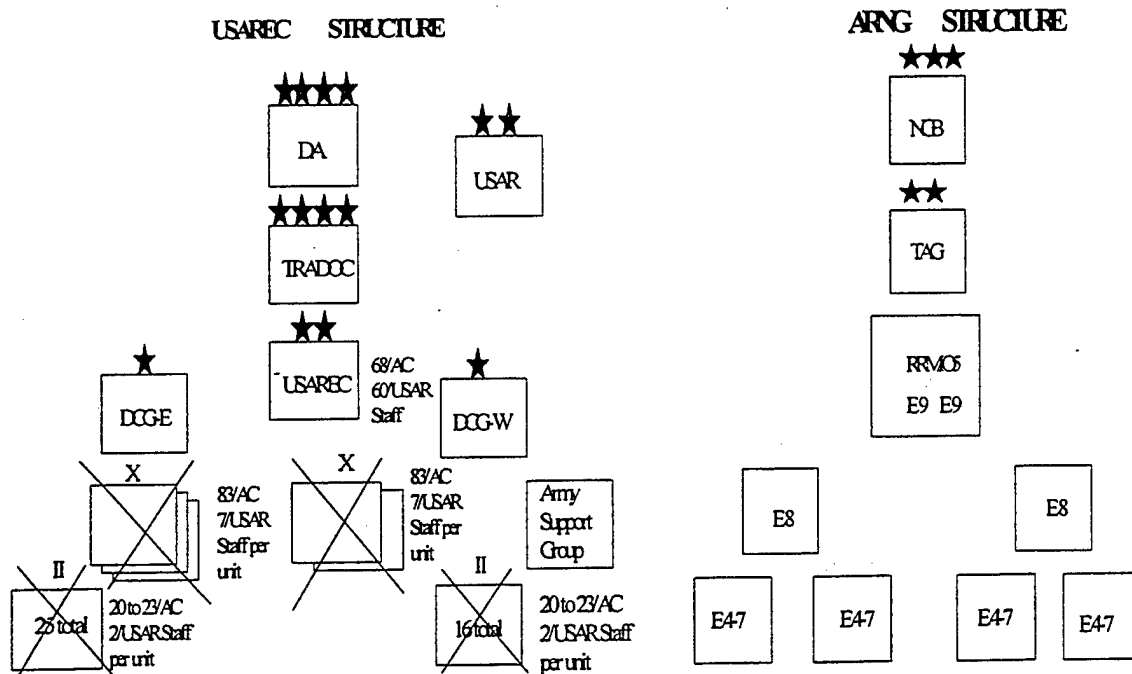

Note: Not all staff positions from the Brigades and Battalions will be saved. Some would need to transfer and merge into the ARNG structure to augment current staff elements to compensate for the increase in recruiter support now needed in each state.

The new total Army recruiting structure will primarily come from the ARNG organizational infrastructure. The ARNG state strength readiness staffs will be augmented with minimal but essential members from other components to help support the total Army recruiters; all recruiters will now be TOTAL ARMY RECRUITERS.

Its important at the beginning to choose leaders in this STAR system who will encourage synergy among the components to defeat the us-them syndrome and bring the Army together in

its most important mission of filling the ranks. The ARNG manages its recruiting force with NCOICs that have been successful recruiters themselves and only a few officers within the unit chain of command. If the STAR structure will follow this design, many company grade officers and first sergeants can return to the AC force. Mid-level NCOs will form tri-component squads of area professionals under the leadership of state recruitment managers (E8s/AC, USAR, ARNG). These will report to the state rotational recruiting officers (one Lieutenant Colonel and two assistant Majors), which come from all three components. The TAG (two star ARNG) of each state, in concert with the STAR commander (two star ARNG) will be responsible for manning the total force. Some fear special attention will be given to component interests. However, the senior leadership needs to emphasize that there is only success when all three missions are satisfied and quickly discourage parochial interests. With recruiting officers from all three components, self-centered actions will diminish.

PROPOSED RECRUITING FUNCTIONALITY

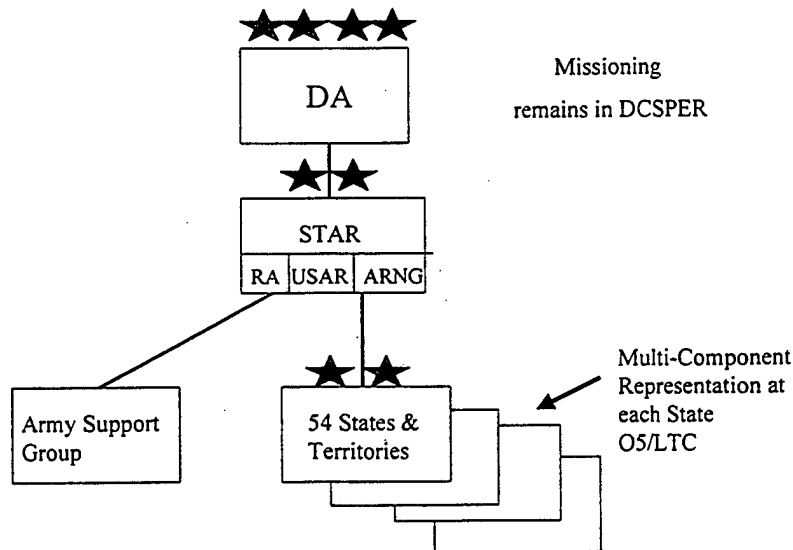

Additional AC staff savings will be attained at USAREC headquarters from the merger, since ARNG personnel will be intermingled with the current USAR and AC staff. There is another ongoing activity we need to mention. USAR or OCAR is currently trying to convert their operations into the configuration and philosophy that ARNG Strength Management has today. They see a success story in the way the Guard does business and wants to capitalize on it.

USAREC should do the same, streamline staff functions and take a hard look at the Guard's Strength Management philosophy.

Some may say that there is too broad a philosophical difference between the two programs: ARNG strength management and USAREC, since ARNG combines recruiting and retention and the AC segregates them. This paper doesn't explore combining AC recruiting and retention structures; however, under this concept NCOs could logically rotate tours between recruiting and retention. This proposal looks at combining the recruiting effort, addressing command structure realignment, adjusting resources, and most importantly – using the strengths already in place to the best advantage of the service. In truth, all the Army leadership needs to do is make the decision, then execute the plan. People instinctively resist change. It's uncomfortable, uncertain, and most of all - risky. Yet, the structure we have now isn't working. It is time for a true structural change.

2. Missioning.

CURRENT SITUATION: Each component has a separate and segregated mission. There is no formal incentive to help each other, so rivalry and divisiveness grow.

RECOMMENDATION: Share the recruiting mission by geographic area.

DISCUSSION: This will cause recruiters to share responsibility for enlisting soldiers into any component. This shared mission should more efficiently attack the prime market, allowing any recruiter to prospect, interview, and offer all component benefit packages to prospective enlistees with balanced pressure toward total mission accomplishment. Thus recruiters sell the Army as a service.

Recruiters will be trained to enlist soldiers into all three components, with the overall mission divided into geographical areas within each state. AC, local USAR, and local ARNG needs will be merged and recruiters will work as teams to meet the area mission. Recruiters will work for this combined area mission, not their previous component mission. Success can only be achieved when all component missions are met.

As a current example, Iowa has 54 ARNG Strength Maintenance NCOs (SMNCO) covering 425 high schools (7.9 average) and averaging about 2 contracts per month per SMNCO. USAREC's Des Moines Recruiting Battalion (with overlap into Nebraska and Illinois) basically covers 519 high schools with 95 recruiters (5.5 average); 77 AC averaging about 1 contract per month, and 18 USAR averaging about 2 contracts per month. With total Army recruiting, these

recruiters would work as a team to produce the number of ARNG, USAR and AC soldiers required for Iowa units and AC MOS needs. Small-town USA, communities with armories but without full-time recruiters, would be better served by geographically dispersing total Army recruiters.

Currently there are no incentives for recruiters of different Army components to share leads, consequently some prospects are potentially lost in the rivalry. However, if recruiters worked together, this would reduce redundancies in prospecting, resulting in more time for interviews and contract writing, increasing probability for recruiter success. Increased production opportunities and better use of resources will raise recruiter morale. Positive teamwork and strong relationships have the propensity to increase production. Working side-by-side with a common goal through shared responsibilities in recruiting a quality force will amalgamate divergent energies into one focused recruiting force.

3. Leadership Responsibility.

CURRENT SITUATION: Most unit commanders and junior to mid-level leaders in the AC are not involved in recruiting accountability, but some USAR and many ARNG commanders have recruiting as part of their evaluation criteria.

RECOMMENDATION: Increase AC leadership involvement in recruiting accountability.

DISCUSSION: Accountability should be shared throughout the commands for the recruiting effort, as the AC does now with retention. Leaders should become involved with local recruiters, increasing opportunities for themselves as well as their soldiers to become intimately involved in the recruiting effort. All soldiers in units should actively seek leads for recruiters in their geographic area and encourage every young person to talk to an Army recruiter. It is critical to systematically integrate commanders at all levels into STAR. Actively encourage commands to get soldiers into the community and tell their personal story of success in a profession of arms, further extending the Total Army Involvement in Recruiting – TAIR program.

Chapter 4 – OPERATIONS

It is important that the operational procedures of Army recruiting be optimized in order to provide the greatest chance for success in “Providing the Force.” This chapter offers new operational innovations and recommends prioritized actions to improve upon existing procedures. Consistent with the overarching strategy of this paper, all recommendations will be implemented and supervised by the Total Army Recruiting Command (led by the Army National Guard).

INNOVATIONS

1. Reduce AC Delayed Entry Program (DEP) losses.

CURRENT SITUATION: AC prospects that do not immediately enter basic training after signing an enlistment contract are placed in the DEP. In effect, the DEP is a holding pool for young Americans who plan to enter the military. Unfortunately, more often than the Army would like, the plans of new enlistees change and the Army suffers a “DEP Loss.” In FY98 the AC lost 33% of its enlistees in the DEP.³⁹

The energy drain of a DEP loss to the recruiting effort is significant. USAREC recruiters spend hours nurturing new DEP soldiers, sometimes working and encouraging them for as long as a year before they are sent to basic training. The time spent on DEP “maintenance” is, once again, time taken from the finite resources of the recruiter’s day.

On the USAR side, reserve Army units take responsibility for their own DEP (in the USAR called the Delayed Training Program or DTP), and these units share with the reserve recruiters a responsibility to take care of new soldiers prior to their ship out to training. In contrast and unfortunately, the AC recruiters do not have the option of placing their DEPs into an AC unit at the present time due to proximity and training issues .

The ARNG unit involvement and commitment to new enlistee maintenance is even more pronounced than the process now working in the USAR. Most ARNG recruiters stay in contact with their new recruits during their basic training. Most significantly, the gaining ARNG unit has a special vested interest in the success of their new recruits because of a strong ARNG unit requirement to maintain personnel strength. Helping in this process of new soldier maintenance and pre-training is an ARNG initiative called the Recruit Training Program (RTP). RTP instructs new soldiers at the unit level. Key new skills such as drill and ceremonies, military

courtesy, proper wear of the uniform, and expectations about basic training are taught to the new National Guardsman.

The result of the unit level involvement with new ARNG recruits seems to work. Non-ship losses for the ARNG were 14.8% in 1998. The key to the ARNG (and in a lesser case, the USAR) success seems to be the placement of a new recruit into a soldiering environment, read – new unit, as soon as possible and providing the new enlistee with involved support and some fundamental military orientation.

RECOMMENDATION: Place the National Guard in charge of the AC DEP.

DISCUSSION: While the USAR recruiters will continue to coordinate with area Army Reserve units in the care and maintenance of their new DTPs, the AC recruiters will turn to the ARNG for cross component support. With the ARNG in charge of the AC DEP, new recruits will be assigned to an ARNG unit. This unit will help to support and prepare the soldier for basic training. An important byproduct of this arrangement is the freeing up of time for all recruiters to spend on finding new Army prospects.

Although there are many apparent benefits to the ARNG managing the DEP, a pay conflict between the components would need to be resolved. Currently, when the ARNG recruits a guardsman, and that soldier reports to weekend drill at an armory, that soldier is paid. This is different from the experience of an AC DEP. An AC enlistee is not paid until they enter Basic Training. Consequently, if the ARNG takes over management of the AC DEP, the AC DEPs, like fellow ARNG soldiers, should be paid for their drills. The good news is that this cost would not be expensive. A new private makes approximately \$890 a month on full time active duty or \$30 a day during a drill period. This relatively small amount of money may well serve as a significant enticement for a young person to remain motivated towards Army service. However, funding needs to be transferred from the AC to the ARNG if ARNG management of the DEP is to work.

2. Train all recruiters together at one location.

CURRENT SITUATION: USAREC (AC and USAR) recruiters are trained at Fort Jackson, South Carolina, while ARNG 79Ts are trained at the National Guard Professional Education Center at Camp Robinson, Arkansas.

RECOMMENDATION: Train all Army recruiters at one location.

DISCUSSION: Consolidation of training at one location would save money, standardize instruction, improve recruiter networking, and enhance total Army integration.

The only projected disadvantage of this arrangement would be the short-term turmoil associated with the movement of the AC/USAR training to Arkansas. This disorder would likely last no longer than 2 years and yet yield long term benefits and resource savings.

3. Create a robust career path for recruiters.

CURRENT SITUATION: The rank advancement for recruiters tops out at Sergeant Major/E9. Senior NCOs, often with ten or more years of recruiting experience, are routinely placed under the command of young captains, whose only USAREC experience is the 3 weeks of schooling at Fort Jackson.

RECOMMENDATION: Create a Warrant Officer Recruiting Specialty.

DISCUSSION: Many NCOs who choose to become career recruiters quickly rise (after about 5 years) to a level where their knowledge and capabilities have outpaced their career opportunities. To add insult to injury, these seasoned NCOs are required to answer to officers who have little to no expertise in recruiting. A way to improve upon this current situation is to create a recruiting warrant officer specialty. These warrant officers would work within the STAR concept as operations officers or area supervisors. A new recruiting Warrant Officer One could be assigned as a senior state guidance counselor or area operations officer. A Chief Warrant Officer Two could serve as a state operations officer or executive officer. The advantage of this career progression is a quantum jump in the credibility of a recruiting area supervisor, a supervisor who would be instantly recognized as a subject matter expert by his former peers(NCOs). Additionally, the warrant officer rank offers a modicum increase in the prestige of the NCO and a substantial pay raise, two positive incentives for an aggressive young sergeant.

The downside of this arrangement is that Personnel Command (PERSCOM) would need to develop the force structure for such a career path. In the past, manpower changes have taken considerable coordination and staffing at the Department of the Army level.

4. Emphasize the *Vocational* Aspect of the Armed Services Vocational Aptitude Battery Test.

CURRENT SITUATION: The Armed Services Vocational Aptitude Battery (ASVAB) test is a strong tool for Army recruiters. When administered as part of a comprehensive and integrated recruitment plan, it helps to identify potential candidates for military service. Usually taken

during the junior year in high school, the ASVAB points to areas of strengths and weaknesses in a young student. Such a test can be extremely helpful to vocational counselors at the high school and college level.

For the Army recruiter the ASVAB opens the door to a potential enlistee. The test can help to establish a name, school and phone number. In short, the ASVAB is an excellent lead source for the recruiter. With a school list developed from the ASVAB, the recruiter can quickly refine his daily planning and prospecting efforts. Unfortunately, not all high schools administer the ASVAB. For example, testing is mandatory in Pennsylvania but not in Connecticut. Yet, even when a school permits testing, it does not guarantee that the high school administration will release a school list to Army recruiters.

RECOMMENDATION: Encourage the Department of Education to mandate the administration of a Vocational Aptitude Test (VAT) to all high school sophomores to improve vocational counseling. (This would be the renamed ASVAB.) Then provide federal funds to those schools that provide student lists to recruiters of the armed services. Also include a VAT baseline score entry on all SAT/ACT results.

DISCUSSION: Recruiting needs to inject itself into the vocational thought process of young people at an earlier age than is now common. Testing in the sophomore year of high school will provide one way to get to America's youth sooner.

Dropping the Armed Services from the Vocational Aptitude Test (VAT) is an easy concession toward increasing the acceptance of the VAT to teachers and career counselors. Indeed, there should be little resistance about assisting young Americans to find their special niche in the work force.

Likewise, providing federal funds to those schools that support the recruiting effort should be well received by educators. In the near term this support could be in the form of a hard copy student list, while in the future, after the issue of privacy can be worked out, students' propensity toward military service could be provided to the Army recruiter through access to an Internet database.

The availability of federal resources to supportive schools need not be viewed exclusively as money. Programs such as the Junior ROTC program, strongly courted by many schools, is an example of a program that can be prioritized to those school districts that encourage the discussion of the Army service option. However, it is important that the availability of resources

for supportive schools be carefully monitored by the recruiting command to dissuade arbitrary judgments of what constitutes cooperative school districts. Otherwise, the intent of this incentive program could become an exclusive, punitive system at odds with the aim of developing a positive association with the United States Army. Fairness of federal funding should be enhanced by the cooperation of the state TAG with the state Department of Education.

Finally, tying the VAT to the Scholastic Aptitude Test (SAT) and the American College Test (ACT) would symbolically provide an intellectual endorsement of the value of the VAT.

IMPROVEMENTS

1. Stop the Recruiting Competition among Army Components.

CURRENT SITUATION: The Army recruiting effort is now divided among the three components of the Army. This process encourages competition among recruiters and spurs the efforts of some recruiters to outperform their rivals.⁴⁰ When a potential Army candidate now walks through the door in a typical recruiting station anywhere in America, he is usually met by an AC recruiter that will spend 1-2 hours attempting to convince the prospect that he should join the real Army. Only after ascertaining that the candidate has absolutely no interest in joining the service is a sale of desperation attempted. That is, a pitch is made to try to convince the prospect to join the USAR.

In a similar manner, a USAR recruiter may conduct the same type of slanted sales approach to another potential soldier. In both cases, what is missing from the sale is an explanation of the full spectrum of available options - an understanding of the advantages and disadvantages of two of the three components of the Total Army: the USAR and AC. The third component of the Army triumvirate, the National Guard, is NOT addressed. Indeed the ARNG is more often than not viewed as a resource competitor of the AC and USAR, with its own unique and separate recruiting chain and effort.

A striking example of this recruiting competition can be seen daily in the community outside the front gates of the Army Recruiting Command Headquarters, Fort Knox, Kentucky. In the small town of Radcliff, Kentucky, not ten miles from the desk of the USAREC Commanding General, there are two recruiting stations, located side by side in a small strip mall. The AC/USAR recruiting station advertises a \$50,000 Army College Fund, while the National Guard recruiting station, the next door over, offers 100% College Tuition. This one-upmanship

in the capital of Army recruiting and elsewhere in the United States must stop as the competition hurts all components.

RECOMMENDATION: Place a single component (the Army National Guard) in charge of Total Army recruiting, requiring them to provide supervision of the recruiting effort.

DISCUSSION: Placing one component in charge will eliminate competition from the job of recruiting, force cooperation, and will likely result in higher recruiter production.

The precedent for this action has already been set. Initially, the present Recruiting Command, formed on 1 October 1964, recruited exclusively for the Active Component. In 1979, USAREC's mission was expanded to include recruiting for the United States Army Reserve.⁴¹ Adding the Army National Guard at the top of a recruiting triad is an innovative but feasible step toward the goal of a seamless Army.

2. Modernize Recruiting Administration.

CURRENT SITUATION: Today's recruiting is labor intensive. At least four hours a day are spent prospecting (phone calls, referrals, or face-to-face contacts with applicants). This prospecting is in addition to a daily planning requirement, a continuous need to sell the Army, a processing demand, and finally the necessity to maintain recruits in the DEP pool. During the execution of each of these recruiting duties, the recruiter is required to document his actions. Among these many administrative dictates are the requirements to record his telephone calls, to write in his planning guide, to fill out his lead refinement list, to update his centers of influence form, and to annotate his 200 card box (a four division file folder).⁴²

Although this paperwork, if correctly and energetically administered, helps the recruiter, it is extremely time consuming and redundant, and it takes away from the available energy he could devote to face-to-face contacts.

RECOMMENDATION: Use computer automation and interactive software programs to assist recruiters in the performance of their duties. Establish a computer distribution plan which cascades technology down in accordance with a prioritized plan. Upgrade hardware every 24 months. Accept the fact that the command can never be truly state of the art due to the cost of leading edge technology. Accept a two-year lag time behind the latest technology as a methodology to enhance job performance. Upgrade computer software programs, via the Internet, as needed.

DISCUSSION: USAREC is in the process of implementing many of these automation recommendations. New Pentium-based laptop computers, called Army Recruiting Information Support System (ARISS), are being fielded to the USAREC force. These laptops are multi-media sales platforms that help the recruiter sell the Army while efficiently documenting the process. A one-time entry into the ARISS database replaces the need for multiple pencil entries across a half dozen or so recruiter management documents.

The down side of this distribution is the time required to equip the geographically separated recruiting brigades. USAREC began issuing ARISS to the brigades in the western United States in 1998 and should finish the fielding to all brigades in USAREC by the end of 1999. In effect, this process will take over 20 months, in time to begin again due to upgrades in computer processors. To the credit of the USAREC ARISS office, this problem has been addressed. By FY00, software will be upgraded via the Internet and computer hardware will be replaced about every 24 months.⁴³

3. Advertise on the Internet.

CURRENT SITUATION: Active Internet advertising is not used. The USAREC Advertising and Public Affairs Office, Fort Knox, Kentucky controls recruiting advertisement. Army television commercials are approved by the Army Chief of Staff and delegated down to the Commanding General of USAREC. Local, regionalized advertisements are seldom authorized.

RECOMMENDATION: Use the Internet to aggressively advertise the Army service option. Establish hyperlinks between the Army Recruiting homepage and the National Guard homepages (and vice versa). Allow more regionalized advertising for the Total Army on radio and television.

DISCUSSION: USAREC now maintains a WEB page (different from active advertising) on the Internet. This site receives 5,000 hits and 30 emails a day. To date this site has provided 1,900 leads per month to the recruiting effort. Obviously, even as a passive form of advertisement, the USAREC Homepage is a key marketing tool for the future.

The New York Advertisement Firm of Young & Rubecan (Y&R) advises and implements the advertisement strategy of USAREC. Due to an analysis of cost effectiveness, Y&R does not recommend that the Army advertise on any of the major online providers. This decision should be reviewed. The online service of AOL alone services 48.5 million subscribers as of March 1999.⁴⁴ A solid interest from less than 1% (.16%) of these subscribers would fill the

Army's recruiting requirement. Perhaps a deal could be negotiated with the CEO of AOL, Steve Case (a West Point Graduate), for a cheaper alumni rate for advertisement banner space on his global online service.

Maintenance of homepages can be time and resource intensive. A possible solution would be to have the Army Recruiting Homepage edited and managed by computer science cadets at West Point. The intelligence and creativity of these cadets plus their age proximity to the potential recruits would make this a relevant and therefore a quality product at an inexpensive price.

Finally, immediate action should be taken by the USAREC staff to establish Internet hyperlinks between the USAREC homepage and the homepages of Army National Guard. This small electronic handshake is a step toward a more cooperative relationship among the three Army components.

4. Use a Contract Telemarketing Firm.

CURRENT SITUATION: The process of finding potential enlistees is called prospecting. Proper prospecting results in leads – finding the specific name and address and/or telephone number of a potential prospect. Prospecting involves establishing rapport with influential leaders of the community, scheduling and conducting visits in the primary quality market – the high school, establishing a network of referrals (P2), and telephone canvassing (P1). Telephone canvassing is time-consuming and the dreaded part of the recruiter's day.⁴⁵ Recruiters spend as much as four hours per day on the telephone prospecting. Their job is made more difficult by the increased use of answering machines, unlisted numbers, and caller identification.

RECOMMENDATION: Use centralized contract telemarketing to initially screen homes and high schools for potential recruits.

DISCUSSION: An initial market screening by professional telemarketers (salespersons) would save many hours for the recruiter that could be reinvested in face-to-face contacts (not to mention quality of life). Although the recruiter must always remain the crucial person to close the sale, telemarketing would greatly reduce the waste of time and effort inherent in finding a receptive person at the other end of the telephone line. Telemarketing transfers the frustration of caller ID and hang-ups to civilian salesmen and saves the Army recruiter's energies for the handling of live leads.

To ensure success, telemarketing must be an incentive-based program with bonus pay provided for the number of good appointments provided to the Army recruiter.

The downside of telemarketing is twofold. One, few people like to talk to telemarketers. Therefore, the potential exists that telemarketing may further alienate an American public already turned off to recruiting. Presently, although P1 (telephone) prospecting is hard for the individual recruiter, most NCOs project a genuine passion for their chosen profession that even the best telemarketer cannot convey to an Army candidate.

Secondly, transitioning to civilian telemarket prospecting will separate the individual recruiter from prospect development. Although the P1 process is laborious, it helps the recruiter to blueprint the local area. A successful recruiter that conducts good phone procedures can work second and third hand, word-of-mouth leads into potential recruits. Placing a civilian firm in charge of P1 may distance the recruiter from the day to day development of enlistment leads. This is acceptable if the civilian firm is competent, but if not, and the NCO is forced back into the important job of telephone prospecting, problems will result. If a telemarketing firm develops a negative rapport in the community it will likely take from six months to two years to regain the market. In the current desperate state of enlistment requirements such a setback would be catastrophic.

Bottom line – the use of civilian telemarketing firm is a potential production enabler that should be tried. Fortunately, USAREC is now testing the telemarketing concept. This 90-day test (to end April 99) is being conducted in Atlanta and St. Louis by the ICT telemarketing firm. The initial results of the ICT test seem positive. In April of 1999, APAC Telemarketing will begin a similar test in six regions--among them, Baltimore, Chicago, Phoenix and Southern California. A decision by USAREC on the viability of telemarketing will be made by the summer of 1999.⁴⁶

5. Screen the Force for Potentially Successful Recruiters.

CURRENT SITUATION: Not all NCOs are salesmen. Most enter the recruiting force without prior sales experience. Once in the USAREC command, they see that recruiting is unlike any other job they have had in their military careers. Some, more by virtue of their personalities than talents, succeed in recruiting. Some do not.

RECOMMENDATION: Test the force for successful behavioral performance traits.

DISCUSSION: Develop a personality or capabilities profile of what it takes to be a successful recruiter. Administer a test like the Stanford Briggs-Meyer Personality Test to all NCOs at the Basic NonCommissioned Officer Course (BNCOC). Use the results to counsel selected NCOs as to their propensity for success in the recruiting command.

The Program Analysis and Evaluation (PA&E) office of USAREC conducted an informal study of 158 recruiters in 1998 and validated, with 86% accuracy, that you can predict which NCOs will make successful recruiters. PA&E conducted this analysis through the use of the Sixteen Personality Factor Questionnaire (16PF) and the Shipley Institute of Living Scale. USAREC has tasked the Army Research Institute (ARI) to further analyze their data and to develop a successful recruiter profile. The results from ARI are due by March of 2000. PA&E projects that screening NCOs that are predisposed to the rigors of recruiting will increase production and drive down costs. They predict an annual savings of \$1.2 million and an increase of 17,000 contracts across the command.⁴⁷

6. Combine incentive packages and enlistment bonuses.

CURRENT SITUATION: Each component has separate and distinct incentive packages and enlistment bonuses.

RECOMMENDATION: Synchronize incentive packages and enlistment bonuses across Army components.

DISCUSSION: Allow service in any or all components. Sell the Army first as the service of choice, and then match the soldier to the correct benefit package. All Army recruiters would be focused on selling the Army. This is an improvement over parochial interests that pit three components against each other in a battle for enlistments. This procedure would help reduce recruiter stress because they would have a wider range of benefits to offer the prospect. For example, a soldier enlists for active service for a period of two years to receive a cash bonus and training in his MOS. He returns home to attend college but must remain a member of the reserve component to receive educational benefits.

7. Share facilities to save money, enhance integration, and better serve the prospects.

CURRENT SITUATION: USAREC and ARNG currently conduct separate recruiting efforts out of separate facilities.

RECOMMENDATION: Stop renting recruiting stations that do not have significant walk-in traffic producing enlistments.

DISCUSSION: ARNG armories provided offices for ARNG recruiters, but they don't spend their time there. ARNG recruiters spend time in the community and schools, just as USAREC recruiters do. Co-locating all Army component recruiters together at a shared facility would save money, enhance recruiter networking and component integration, and better serve the new prospect.

Chapter 5 - CULTURE

This chapter looks at the dynamic of culture and its place in change. The Army's culture and traditions are strong and engrained; that is why leaders must take caution when they dabble with change. The concepts and visions that drive change must be both inspiring and realistic, based on an assessment of that particular organization's strengths and traditions. Clearly there is no organizational alchemy capable of transmuting an auto company into an electronics firm; there is only the hard work of searching for those innovations which fit the life stage and thrust of each company. ⁴⁸

CURRENT SITUATION: There is one true culture with three distinct components within the Force today, all three in competition with each other and often pulling in divergent directions. This chart illustrates there are more similarities among all three components than differences, and that the actual differences are minor compared to the total Army mission.

TRICOMPONENT COMPARISON

	Ethics & Values	Training	Professional Education	MOS Qualified	Soldier	Civilian Job	Missions
AC	AS	AS	AS	AS	FULL	N/P	FED
USAR	AS	AS	AS	AS	F/P	F/P	FED
ARNG	AS	AS	AS	AS	F/P	F/P	ST/FED

AS=Army Standard, F/P=Full & Part Time, N/P=None & Part Time, ST=State, FED=Federal.

RECOMMENDATION: Implement Seamless Total Army Recruiting (STAR) and recognize that the Army culture will change.

DISCUSSION: STAR does not deliberately target the culture for change. Culture is a byproduct of strategy, structure and operations. ⁴⁹ Let the changes in the other three dimensions affect culture. Implementation of STAR should improve inter-component communications, educate components on each others' capabilities through close working exposure, and glean both resource and manpower efficiencies, creating a positive shift in culture.

The key to successful change is to pay attention to an organization's culture and use it. Don't attempt to directly change the culture. Instead look at the cultural aspects that make or break an institution and nurture them to support the change. More than any other service, the

Army is totally dependent on its individuals and their teamwork. No one fights alone in the Army, and yet at any moment without notice any individual can become the leader. Because soldiers are interdependent literally for their lives, there must be a strong belief that each will take care of the group whether it's a squad, company, battalion or adjacent brigade. This belief or trust grows out of training, proven performances, and continuous successful contact with each other in pursuit of common goals. Use these traits in restructuring organizations to drive cultures together. Reinforce these changes through operational improvements and innovations that reduce competition and DEP attrition, while enhancing recruiter career progression and job performance. All contribute to cultural change.

As stated in One Team, One Fight, One Future, "The seamless, single integrated Army of the future will not only be bound together by its structures and systems, but will also be forged with the Army's enduring commitment to teamwork, discipline, values, and absolute trust."⁵⁰ This new recruiting structure, with recruiters, staffs, and commanders working together will enhance integration and build positive, respectful, trustful relationships throughout the total Army.

This teamwork also involves capitalizing on individual strengths to make the mission successful while identifying and improving individual weaknesses so the whole becomes stronger at its weakest link. These dynamics of personal and organizational growth are intertwined, as are the initiatives of integration. To realize success, take the strengths of the one (ARNG recruiting) and enhance the rest of the organization (AC, USAR - USAREC), thereby strengthening the whole (ARMY). Put the ARNG in charge of recruiting and see the cultural elements evolve into a Total Army of teamwork and true trust.

Chapter 6 - IMPLEMENTATION

CURRENT SITUATION: Chapters 2-4 outlined one possible approach to forming a total Army recruiting command that capitalizes on current strengths of existing programs.

Implementation of this new structure will require many steps that this chapter will describe in a recommended timeline.

RECOMMENDATION: Implement STAR.

DISCUSSION: The timeline that follows is only one of many possible ways to implement total Army recruiting. The timeline is phased, easily changed, and only a broad outline of what would actually have to be done to achieve the outcome. The pathway to STAR will be a sequenced, incremental building process that seeks to transition the Army recruiting effort from its present state to a seamless organization. One possible roadmap to STAR, which incorporates the previous rationale and arguments of this paper, is listed below.

Two important assumptions in the development of this timeline are that a significant downturn in the economy does not occur and an overwhelming threat to United States security does not emerge. The occurrence of these events would have a measurable result on the recruiting environment.

TIMELINE:

JUNE 1999 – This research paper with the recommendation for STAR is received by the DA leadership and tasked out for study. A tri-component working group could be established to define functions and processes that are common, as well as current differences that could be ameliorated to combine the recruiting programs. Milestones would need to be set to ensure timely progress. This study group will decide if the proposal is valid or not. If valid, they may decide to continue with further study or to conduct a test. The authors recommend the choice of a test state as described in Chapter 3 and current USAREC battalion/brigade. This state and battalion/brigade would combine their staffs and recruiters, would work together to recruit for all components, and report the outcomes of their test. The rest of this timeline assumes a decision to move forward is made.

Phase One

JANUARY 2000 – If it hasn't begun already, active internet advertising begins on the major on-line providers (AOL, MSN). This advertising will include intrusive e-mail that addresses specific interests discovered through computing software transponders.

FEBRUARY 2000 – All ARISS laptops are issued to all components with supply system emplaced for biannual distribution of new automation hardware, and all software upgrades are done on-line as needed and authorized from Recruiting Command Headquarters.

JUNE 2000 – Plans are started to combine recruiter training. Concurrently, the ARNG assumes complete management of the Army DEP soldiers. They are integrated into the recruit training program to train skills helpful to basic training success.

OCTOBER 2000 – Recruiter training is consolidated at the ARNG Professional Education Center, Camp Robinson, Arkansas. Recruiters from all components are trained at this location with the same program of instruction that includes core subjects, benefit packages, and contract writing for all components.

Phase Two

THE YEAR 2001 – This year is spent in an effort to standardize requirements, paperwork, incentives, and consolidate marketing analysis and advertising functions. Recruiters are consolidated by areas and NCOICs are selected and trained.

JANUARY 2001 – Contracted telemarketing begins. A civilian telemarketing firm will be paid according to the number and quality of live leads it provides to total Army recruiters. The contracted marketing firm will only be required to find eligible 17-34 year olds who have expressed an interest in learning more about the opportunities and options of the Army. The telemarketing firm will then transmit the lead through the established automation channels. The end state is a situation where the recruiter, upon coming into work in the morning, finds a printout on his desk, computer screen, or pager with the name, address and primary buying motive of a new contact. The NCO, the legitimate subject matter expert on the military, then travels for a face-to-face interview to close the sale with the potential enlistee.

Phase Three

JANUARY 2002 – ARNG Major General initially assumes command of the Total Army Recruiting Command, concurrently with two Brigadier Generals/Deputy Commanding Generals from USAR and AC. These assignments could be rotated between components. DCGs will

assist CG in the conduct of his/her recruiting mission. The geographic location of this command should be selected based on the best fit for the Army.

Concurrently, Recruiting Command leadership supervises the melding of the old USAREC battalion and brigade hierarchy into the total Army recruiting effort. Each state retains the LTC management and adds a major from two other components so the leadership team is multi-component.

JANUARY 2002 – The first total Army recruit processes through a STAR recruiting station.

The following story is a positive example of what's possible with total Army recruiting. SSG Smith has the ability to offer the entire range of benefits available. She sells the Army as a service and then matches the needs of the prospect to the component. The new recruiting strategy will allow the total Army mission to be sold, the structure is supportive rather than competitive and divisive, and the operational procedures in place will increase the recruiter's opportunities for success.

A TOTAL ARMY RECRUITER CLOSES THE SALE

Background:

SSG Smith is a Total Army Recruiter School graduate. She, her teammates, and NCOIC are a combination of AC, USAR, and ARNG recruiters. She prospects and gets to know the soldiers in the ARNG and USAR units within her recruiting area. Her office space is in the ARNG armory, a place for her to make phone calls, conduct appointments, and write contracts. She spends most of her time at her high schools, attending community events, and getting to know the centers of influence in her community.

SSG Smith prospects with these centers of influence, receives leads from all area unit members, and routinely receives leads from the centralized telemarketing contractors. Her prospecting is time-effective and not paperwork intensive.

SSG Smith likes the total Army recruiting structure. Not only is she not in competition with other component recruiters, they are actually expected to recruit as a team. She believes this integrated approach better serves the prospects, saves the Army money, reduces her stress, and causes the recruiters to be more effective in the schools.

Monday:

SSG Smith spent time at the local unit's drill last Saturday, and today she has a lead to follow up. She calls the prospect, Tom Brown, after he returns home from school. He wants to talk to a recruiter, but doesn't want to commit to anything since he is just starting his senior year. He is undecided about college, and his mother is a single parent with four young children to take care of.

SSG Smith suggests they meet at the Brown home, so Tom's mother can hear the Army benefits and not have to find a babysitter. An appointment is set for Wednesday evening.

Wednesday:

SSG Smith arrives with her presentation materials. She introduces herself and tells Tom how great it is that he wants to serve his country in the military. Tom stops her abruptly by telling her he just wants to hear what the military has to offer him. SSG Smith explains what the Army has to offer as compared to the other services, emphasizing the choice of over 250 jobs if he qualifies. Tom has an interest in computer programming, and he knows how much more money he could make in the civilian job market. SSG Smith explains that may be true, and she asks if a college degree is necessary to qualify for that great civilian job. Tom agrees that is probably the case. SSG Smith opens her laptop system, the Army Recruiting Information Support System (ARISS), that she was sure to upgrade before leaving the office.

SSG Smith takes this opportunity to explain the Army College Fund and the Montgomery GI Bill. Tom's mother takes interest, as she has no idea how to send Tom to college other than applying for financial aid. She asks how long he would be gone because she really needs him around to help with the other children. The recruiter explains about the new bill before Congress that would grant tax benefits to parents who have children serving in the military, as well as the new initiatives being worked with the state for employment guarantees to veterans who return to their home state.

SSG Smith takes this opportunity to ask Tom whether he would like active or reserve service. He hasn't thought about it much, so she explains all the options available to him. Active duty would take him away from home, give him a new skill, and he could qualify for enlistment bonuses, as well as educational assistance. He would have to put his college on hold until he finishes his contract period. Night school would be difficult because of the amount of time he would likely be deployed.

SSG Smith goes on to explain, if Tom's priorities are to start college and be close to home, the National Guard or Army Reserve are perfectly suited for him. Since Tom lives in Illinois, if he joins the National Guard, he would receive 100% tuition assistance and his drill pay. He would be away from home long enough for Basic Training and Advanced Individual Training and be required to train two weeks annually and one weekend a month. The nearest National Guard armory, about ten miles away, has a maintenance unit. She also explains there is a reserve center with a medical unit about thirty miles away. The Army Reserve has similar time requirements, but the educational benefits are a little different. Either reserve opportunity gives him a job skill, just like active duty, he could go to school and stay close to home; however, deployment is always possible, especially now that the reserve component is over 50% of the total Army. The recruiter goes on to explain about the certification program being considered by the state. In essence, if Tom becomes an Army mechanic, he would also be state-certified on some types of equipment. SSG Smith runs a Computer Adaptive

Screening Test (CAST) to provide Tom a prediction of his VAT (formerly ASVAB) score and a list of job possibilities.

Tom and his mother agree they hear many positive benefits to service in the Army. In fact, they want to talk about it further after Tom takes the VAT to see how he qualifies. SSG Smith schedules Tom for the next testing session at the armory.

One Week Later:

The rest of the sale is easy because Tom qualifies for several MOSs, to include maintenance and medical. He thinks joining the Army is the only way for him to go to college, but he feels a great need to help his mother at home. SSG Smith again reminds Tom that the choice is his, she shows him the entire range of benefits, and she asks Tom which component best suits his needs.

SSG Smith closes the sale, schedules Tom's MEPS appointment, and starts the rest of his paperwork. She calls her NCOIC with the good news.

CONCLUSION:

This paper outlined the current recruiting challenges, proposed a new strategy based on structural change, included some operational innovations and improvements, hinted at possible cultural change, and gave a timeline for implementation.

The current Army recruiting systems can be merged to form a total Army recruiting effort that will better serve the prospects and achieve the accessions needed for the Army. Continuing to increase monetary incentives, changing advertising, or adding more recruiters will not be effective fixes for current recruiting challenges. Stepping back and looking at a structural way to merge the components into one recruiting team provides a start point for total Army recruiting.

If implemented, this new recruiting strategy will fit the Army's mission, emerge from a structure that's in place but modified, optimize resources, realize efficiencies, and lead to enhanced integration of the force.

END NOTES

- ¹ Janelle Shubert, "Affecting Successful Change in Organizations," Harvard Lecture, August 1998.
- ² The most responsive units were the 6th and 1st recruiting brigades.
- ³ Although only 36 of 1550 recruiting stations were directly emailed it must be recognized that each contact with the battalion and brigade headquarters was a potential contact with all recruiting stations in that command. In fact, the 6th brigade and one battalion in the 1st brigade redirected our email out to all their recruiting stations.
- ⁴ From Army Times and Military City On Line. Homepages. 15 January 1999.
- ⁵ U.S. Army Recruiting Command Publication Series. Ft. Knox, Kentucky. AC OCT 96. Y NOV 96.
- ⁶ Joseph L. Galloway, *Not in the Army Now* (U.S. News and World Report, 1 March 1999).14.
- ⁷ Jane McHugh, *Recruiting Deficit Looms Larger* (Army Times, 9 November 1998) 12.
- ⁸ McHugh 12.
- ⁹ McHugh 12.
- ¹⁰ USAREC Functional Area Review, 15 March, 1999.
- ¹¹ USAREC Functional Area Review, 15 March, 1999.
- ¹² McHugh 12.
- ¹³ MG Mark Hamilton, CG USAREC. "Harrisburg Recruiting Battalion Annual Training Conference," Briefing. 9 November 1997.
- ¹⁴ MG Evan R. Gaddis, USAREC CG, "USAREC Functional Review," Briefing, 19 February 1999, Slide 6.
- ¹⁵ MG Mark Hamilton 8 November 1997.
- ¹⁶ Phone conversations with 1st and 2nd Recruiting Brigade Budget offices, 15 December 1998 and 10 January 1999.
- ¹⁷ Lisa Daniel, *Officials Concerned with 99 Recruiting Goals, Budget Gap* (Army Times, 9 November 1998)13.
- ¹⁸ USAREC Briefing to General Dennis Reimer, CSA, 20 November 1998.
- ¹⁹ Office of Economic & Manpower Analysis, Department of Social Sciences, "Unemployment and the DEP & Recruiting," United States Military Academy Briefing. 14 January 1999, Slide 13.
- ²⁰ "Unemployment and the DEP & Recruiting," Slide 3.
- ²¹ Tobias Naegele, *The Pay Gap* (Army Times, 9 November 1998) 3.
- ²² Naegele 3.
- ²³ Rick Maze, *Fewer in Congress have Military Service* (Army Times, 23 November 1998) 8.
- ²⁴ Thomas W. Lippman, *Socially and Politically, Nation Feels the Absence of a Draft* (The Federal Page, Washington Post, 8 September 1998) 4.
- ²⁵ Lippman 3.
- ²⁶ Des Moines Recruiting Battalion Briefing, December 1998, Slide 19.
- ²⁷ Des Moines Recruiting Battalion Briefing, Slide 19.
- ²⁸ Daniel 13.
- ²⁹ Rick Maze, *Recruiters: High Rate of Quitters Top Problem* (Army Times, 23 March 1998) 26.
- ³⁰ Lippman 2.
- ³¹ Rosabeth Moss Kanter, *The Change Masters: Innovation & Entrepreneurship in the American Corporation* (New York: Simon and Schuster, 1983) 69.
- ³² Gordon R. Sullivan & Michael V. Harper, *Hope is not a Method: What Business Leaders Can Learn From America's Army* (New York: Times Business, 1996) 98.
- ³³ Kanter 279.
- ³⁴ General Dennis J. Reimer, CSA, "Remarks on Personnel Readiness", Briefing, 29 September 1998.
- ³⁵ Kanter 299.
- ³⁶ William S. Cohen, Secretary of Defense, *Annual Report to the President and the Congress*, 105th Cong., 2nd sess., 1998, 83.
- ³⁷ Office of the Chief of Staff of the Army, *One Team, One Fight, One Future*, 2 December 1998, Pg2, <http://www.hqda.army.mil/ocsa/chief.htm>.
- ³⁸ Army Force Structure: AC/RC Integration (AUG 98), *AC/RC Force Structure Initiatives*, 2 December 1998, <http://www.paed.army.mil/acrc/fs/fs0.html>.
- ³⁹ Colonel Greg Parlier, Director of Program Analysis & Evaluation, USAREC HQS, personal interview, 27 January 1999.
- ⁴⁰ James R. Thomas, *Reengineering DoD Recruiting* (RAND Issue Paper, 1997) 10.
- ⁴¹ USAREC Homepage, *History of Army Recruiting*, 15 February 1999.

⁴² U.S. Army Recruiting Command Regulation 350-6, *Recruiter Production Management System*. Ft. Knox, Kentucky, 24-29.

⁴³ LTC Gary Minadeo, personal phone conversation interview 18 March, 1999.

⁴⁴ Daniel Kadlec, *ATT&T Betting on Its Business* (Time Magazine, 15 February 1999) 46.

⁴⁵ Results of email survey with ARNG and USAREC recruiters, February 1999.

⁴⁶ U.S. Army Recruiting Command visit 10 to 12 March 1999, personal interviews with numerous staff officers.

⁴⁷ Major Robert H. Fancher, Jr., Market Analyst for USAREC, personal interview, 13 March 1999.

⁴⁸ Kanter 306.

⁴⁹ Shubert August 1998.

⁵⁰ Office of the Chief of Staff of the Army 21.

Works Consulted

- 1st Recruiting Brigade Budget offices, U.S. Army Recruiting Command, Ft. Meade, Maryland. Telephone interviews. 15 December 1998 and 10 January 1999.
- 1st Recruiting Brigade, U.S. Army Recruiting Command, Ft. Meade, Maryland. E-mail surveys. December 1998 through February 1999.
- 2nd Recruiting Brigade Budget offices, U.S. Army Recruiting Command, Atlanta, Georgia. Telephone interviews. 15 December 1998 and 10 January 1999.
- 2nd Recruiting Brigade, U.S. Army Recruiting Command, Atlanta, Georgia. E-mail surveys. December 1998 through February 1999.
- 3rd Recruiting Brigade, U.S. Army Recruiting Command, Indianapolis, Indiana. E-mail surveys. December 1998 through February 1999.
- 5th Recruiting Brigade, U.S. Army Recruiting Command, San Antonio, Texas. E-mail surveys. December 1998 through February 1999.
- 6th Recruiting Brigade, U.S. Army Recruiting Command, San Francisco, California. E-mail survey. December 1998 through February 1999.
- Adelsberger, Bernard. *Recruiters Hit the Mark for '94/But When Drawdown Ends in 1996, Recruiting Goals are Expected to Rise Sharply*. Army Times, 7 November 1994.
- Adelsberger, Bernard. *The Hard Sell/Why Recruiting Has Gotten So Tough*. Army Times, 13 February 1995.
- Advertising and Public Affairs Directorate, U.S. Recruiting Command. *American's Army – Transmitting the Message*. Briefing, February 1999.
- Ames, RADM F.L. *Overview of our FY99 Workforce Restoration Plan*. Message from Commandant Coast Guard, Washington, DC, 11 January 1999.
- Analysis Briefing. *Unemployment and the DEP & Recruiting*. Office of Economic & Manpower Analysis, Department of Social Sciences, United States Military Academy, 14 January 1999.
- Army 1997-1998 Green Book*. Association of the United States Army, October 1997.
- Army Force Structure: AC/RC Integration (AUG 98), *AC/RC Force Structure Initiatives*, 2 December 1998, <http://www.paed.army.mil/acrc/fs/fs0.html>.
- Army National Guard Fact Sheet*. National Guard Homepage, 2 December 1998.
- Army National Guard Fiscal Year 1998 Posture Statement*. Army National Guard Homepage, 2 December 1998.
- Army Regulation, AR 601-210. *Regular Army and Reserve Enlistment*. Headquarters Department of the Army, Washington, DC, November 1998.
- Army Times Homepage. 15 January 1999.
- Asch, B.J. & Karoly, L.A. *The Role of the Job Counselor in the Military Enlistment Process*. RAND CORP, MR-315-P&R, 1993.
- Baca, MAJ Brian, National Guard Bureau. Personal interview. 29 October, 1998.
- Bloomer, MAJ Steve, Iowa ARNG. Email interview. 7 January 1999.
- Bowie, Robert & Immerman, Richard. *Waging Peace*. Oxford University Press, New York 1998.
- Bowman, Tom. *Military Recruiters Losing War At Home*. Baltimore Sun, 3 November 1998.
- Bracken, Paul. *The Military After Next*. Washington Quarterly, Autumn 1993.
- Breitling, Glenn C. *The Army Reserve: Relevant in Force XXI*. U.S. Army War College, 15 April 1997.

- Brock, MAJ Clay, National Guard Bureau. Personal interview. 29 October 1998.
- Buddin, R.J., & Grissmer, D.W. *Skill Qualification and Turbulence in the Army National Guard and Army Reserve*. RAND CORP, MR-289-RA, 1994.
- Buddin, R.J., & Kirin, S.J. *Army Reserve Component Accession from Personnel Completing Their First Active-Duty*. RAND CORP, MR-258-A, 1994.
- Buddin, R.J., & Polich, J.M. *The 2 + 2 + 4 Recruiting Experiment : Design and Initial Results*. RAND CORP, N-3187-A, 1990.
- Buddin, R.J. *Assessment of Combined Active/Reserve Recruiting Programs*. RAND CORP, MR-504-A, 1994.
- Buddin, R.J. *Enlistment Effects of the 2 + 2 + 4 Recruiting Experiment*. RAND CORP, R-4097-A, 1991.
- Burlage, John. *Navy will push for \$60,000 reenlistment bonuses*. Navy Times, 19 October 1998.
- Calvert, Brian R. *Force Integration: A Progress Report on Cohen's Memorandum, One Year Later*. National Guard, November 1998.
- Cochran, LTC Lewis, USAREC – Des Moines Battalion Commander. Personal interview. 22 December 1998.
- Cohen, William S., Secretary of Defense. *Annual Report to the President and the Congress*. 105th Cong., 2nd sess., 1998.
- Craciunoiu, Sarah M. *Army changes recruiting policies to meet post-drawdown needs*. Army Link News, 30 November 1998.
- Compart, Andrew. *Congress Keeps Lid On Recruit Arrest Records*. Army Times, 7 July 1997.
- Compart, Andrew. *One Hard Recruiting Year/Strong Economy, Higher Goal Find Army Falling Behind*. Army Times, 14 July 1997.
- Compart, Andrew. *Recruiting Goals Met, But Next Year May be Hard*. Army Times, 18 November 1996.
- Currie, James T. *Twice the Citizen, A History of the United States Army Reserve, 1990-1995*. Department of the Army Pamphlet 140-14, Office of the Chief, Army Reserve, Washington, DC, 1997.
- Daniel, Lisa. *Officials Concerned with 99 Recruiting Goals, Budget Gap*. Army Times, 9 November 1998.
- Daniel, Lisa. *Will Civilians Do the Recruiting?/Senate Proposal Wants to See if Private Sector Can do the Job Better*. Army Times, 15 June 1998.
- Dell, SGM Terry, Iowa ARNG. E-mail interviews. 23 November 1998.
- Demographic Analysis Cell, Program Analysis & Evaluation Directorate, USAREC. Briefing. February 1999.
- Dertouzos, J.N., Polich, J.M., Bamezai, A., & Chesnutt, T.W. *Recruiting Effects of Army Advertising*. RAND CORP, R-3577-FMP, 1989.
- Dertouzos, J.N. *The Effects of Military Advertising – Recruiting and enlistment*. RAND CORP, N-2907-FMP, 1989.
- Des Moines Recruiting Battalion, 6th Recruiting Brigade, U.S. Army Recruiting Command, San Francisco, California. Personal interview and briefing. 22 December 1998.
- Ellington, LTC, United States Army Reserve. Personal interview. 12 March 1999.
- Elliott, COL M. Bruce. *AC/RC Integration White Paper: "One Team, One Fight, One Future"*. U.S. Army Active/Reserve Component Integration, 2 December 1998.
- E-mail sent to the Battalion Commanders for the following Recruiting Battalions: Albany, Baltimore, New England, Harrisburg, New York City, Mid-Atlantic, Pittsburgh,

- Syracuse, Beckley, Atlanta, Jacksonville, Miami, Montgomery, Nashville, Raleigh, Jackson, Chicago, Cleveland, Columbus, Great Lakes, Indianapolis, Milwaukee, Dallas, Houston, Kansas City, New Orleans, Oklahoma City, San Antonio, De Moines, St. Louis, Denver, Los Angeles, Phoenix, Portland, Sacramento, Salt Lake, Southern Cal, and Seattle. December 1998 through February 1999.
- E-mail sent to the following Recruiting Stations: Washington, D.C., Virginia Beach, Norfolk, Boston, Providence, Chambersburg, Carlisle, York, Lancaster, Harrisburg, Reading, Altoona, College Park, Lock Haven, Williamsport, Honesdale, Montrose, Scranton, Wilkes Barre, Hazleton, Bloomsburg, Allentown, Richmond, Los Angeles, Sierra Vista, Salem, Boise, San Diego, Seattle, Kapolei, and Kaneohe. December 1998 through February 1999.
- Email survey with ARNG and USAREC recruiters. February 1999.
- Fancher, Major Robert H., Jr., Market Analyst for USAREC. Personal interview. 13 March 1999
- Fernandez, J.C., & Kawata, J.H. *A System for Allocating Selective Reenlistment Bonuses*. RAND CORP, N-2829-FMP, 1989.
- Fewer in Congress Have Military Service*. Army Times, 23 November 1998.
- Fiscal Year 1998 Recruiting Achieves 97 Percent of Goal for Quantity while exceeding Quality Benchmarks*. Defense Link Homepage, 9 November 1998.
- Freeman, James. *Would you die for your country?* USA Today, 10 February 1999.
- Fukuyama, F. & Shulsky, A.N. *The "Virtual Corporation" and Army Organization*. RAND CORP, MR-863-A, 1997.
- Gaddis, MG Evan R. *Cross Assignment and Achievement Credit for Active Guard Reserve Recruiters Serving in the Recruiting Command*. USAREC Memo for LTG Ohle, 7 December 1998.
- Gaddis, MG Evan R, USAREC CG. *USAREC Functional Review*. Briefing. 19 February 1999.
- Galloway, Joseph L. *Not in the Army Now*. U.S. News and World Report, 1 March 1999.
- Garamone, Jim. *Leaders Propose Pay Hikes, Retirement Changes*. American Forces Press Service, 9 November 1998.
- Garamore, Jim. *DOD Deals New Hand to Reserve Forces*. Defense Link Homepage, 9 November 1998.
- Gauntlett, Dave, Indestructible, Incorporated. *Thoughts on Total Army Recruiting*. Memo for LTC Chris Marsh, et al, 27 January 1999.
- Gerner, COL, Chief, Force Integration and Management Division, HQDA. *AC/RC Integration Item 97-32, Composite (Multi-Compo) Units*. Memo for Reserve Component Coordination Council, 29 October 1998.
- Gilmore, Gerry J. *"New Look" recruiting ads target "Info Age" generation*. Army Link News, 9 December 1998.
- Gorman, Michael A. *Integration of the Army National Guard and Army Reserve into the Army Acquisition Corps: The Next Step*. U.S. Army War College, 15 May 1998.
- Grissmer, D.W., Kirby, S.N., & Sze, Man-B. *Factors Affecting Reenlistment of Reservists: Spouse and Employer Attitudes and Perceived Unit Environment*. RAND CORP, R-4011-RA, 1992.
- Hackworth, David. *Army's Recruiting Efforts Coming Up Short*. Louisville, Kentucky Newspaper, February 1999.
- Hamilton, MG Mark, CG USAREC. *Harrisburg Recruiting Battalion Annual Training Conference*. Briefing. 9 November 1997.

- Haskell, MSG Bob. *Mom becomes California's top Army National Guard recruiter*. Army Link News, 9 December 1998.
- Hays, COL Mark, USAREC. Telephone interview. November 1998.
- Hudson, Neff. *Recruiters on Target in Numbers and Quality*. Army Times, 26 June 1995.
- Hudson, Neff. *Women, Minorities Help Services Hit Recruit Goals*. Army Times, 27 February 1995.
- HQDA, Office of the Chief of Staff. *Total Army Quality*. Leading Change Modular Briefing, CD ROM. Army Management Directorate Strategic Management and Innovations Division, 1998.
- HQDA, Office of the Chief of Staff. *Total Army Quality, Version 1.1*. Leading Change Modular Briefing, CD ROM. Army Management Directorate Strategic Management and Innovations Division, 1999.
- Improve the Recruiter's Lot*. Editorial. Army Times, 23 February 1998.
- Issue AC. *Recruiting Management*. USAREC, Ft. Knox, Kentucky, November 1996.
- Issue Y. *Recruiting Brigade and Battalion Operations*. USAREC, Ft. Knox, Kentucky, October 1996.
- Jensen, MAJ Michael, Recruiting Retention Manager Iowa ARNG. Personal interview. 22 December 1998.
- Kadlec, Daniel. *ATT&T Betting on Its Business*. Time Magazine, 15 February 1999.
- Kanter, Rosabeth Moss. *The Change Masters: Innovation & Entrepreneurship in the American Corporation*. New York: Simon and Schuster, 1983.
- Klein, S.P., Hawes-Dawson, J. & Martin, T. *Why Recruits Separate Early*. RAND CORP, R-3980-FMP, 1991.
- Knapik, COL. *AC/RC Integration Item 97-41, RC Support to USSOUTHCOM*. Memo for Reserve Component Coordination Council, 9 October 1998.
- Komarrow, Steven. *Enlistments in Army Fall 20% Short*. USA Today, 29-31 January 1999.
- Komarrow, Steven. *Weekend Warriors Risk Careers*. USA Today, 15 February 1999.
- Krepinevic, Andrew. *Restructuring Defense for a New Era: The Value of Scenario-based Planning*. CSBA Backgrounder, January 1996.
- Laughlin, Marinaccio & Owens. *Results of Research conducted to test Advertising on behalf of the Army National Guard*. WB&A, Crofton, Maryland, 21 September 1998.
- Lawson, MG Warren G., Adjutant General Iowa Guard. Personal interview. 22 December 1998.
- Ledford, Tranette. *Chaplains Give Spiritual Help to Recruiters*. Army Times, 24 August 1998.
- Le Moyne, MG John M. *AC/RC Integration Item 92-01, Enlistment/Reenlistment of Quality Soldiers*. Memo for Reserve Component Coordination Council, 10 October 1998.
- Le Moyne, MG John M., Assistant Deputy Chief of Staff for Personnel. Personal interview. 20 January 1999.
- Lewis, John P. *The Army National Guard: Meeting the Needs of the National Military Strategy*. U.S. Army War College, 13 May 1993.
- Lippman, Thomas W. *Socially and Politically, Nation Feels the Absence of a Draft*. The Federal Page, Washington Post, 8 September 1998.
- Lovelace, BG. *AC/RC Integration Item 93-02, Title XI FY 93 NDAA*. Memo for Reserve Component Coordination Council, 9 October 1998.
- Lyman, Kevin D. *Integrated Career Plan*. USAREC, Ft. Knox, Kentucky, 22 January 1999.
- Martin, T. *Who Stays, Who Leaves?: An Analysis of First-Term Army Attrition*. RAND CORP, RGSD-114, 1995.

Maze, Rick. *More money for recruits*. Army Times, 15 January 1998.

Maze, Rick. *Recruiters: High Rate of Quitters Top Problem*. Army Times, 23 March 1998.

McCormick, David. *The Draft Isn't the Answer*. New York Times, 10 February 1999.

McHugh, Jane. *Army eyes low number of Hispanics in the ranks*. Army Times, 9 November 1998.

McHugh, Jane. *Coming Up Short/Recruitment Efforts Will Be Reexamined Next Year*. Army Times, 9 November 1998.

McHugh, Jane. *Recruiting Deficit Looms Larger*. Army Times, 9 November 1998.

McHugh, Jane. *Recruits to Get More Money*. Army Times, 23 November 1998.

Meyer, MG. *AC/RC Integration Item 97-20, "TOTAL ARMY" Story*. Memo for Reserve Component Coordination Council, 9 October 1998.

Military Attrition: Better Data, Coupled with Policy Changes, Could Help the Services Reduce Early Separations. Chapter Report, 15 September 1998, GAO/NSIAD-98-213.

Military Attrition: DOD Could Save Millions by Better Screening Enlisted Personnel. Chapter Report, 6 January 1997, GAO/NSIAD-97-39.

Military Attrition: DOD Needs to Better Analyze Reasons for Separation and Improve Recruiting Systems. Testimony, 4 and 12 March 1998, GAO/T-NSIAD-98-109 and 117.

Military City Homepage, 15 January 1999.

Military Downsizing: Balancing Accessions and Losses Is Key to Shaping the Future Force. Chapter Report, 30 September 1993, GAO/NSIAD-93-241.

Military Personnel Policy Major Initiatives. Army Public Relations Homepage, 9 November 1998.

Military Recruiting: DOD Could Improve Its Recruiter Selection and Incentive Systems. Chapter Report, 30 January 1998, GAO/NSIAD-98-58.

Military Recruiting: More Innovative Approaches Needed. Chapter Report, 22 December 1994, GAO/NSIAD-95-22.

Minadeo, LTC Gary. Personal phone conversation interview. 18 March, 1999.

Moniz, Dave. *Army Returns to Varsity Playing Field*. Christian Science Monitor, 27 May 1998.

Moniz, Dave. *Army Toughens Regimen to Retain Co-Ed Training*. Christian Science Monitor, 6 October 1998.

Moniz, Dave. *Young Army Recruiters to Target Young Recruits*. Christian Science Monitor, 11 February 1999.

Moore, William C. *The Military Must Revive Its Warrior Spirit*. The Wall Street Journal, 27 October 1998.

Moskos, Charles & Miller, Laura. *Report on Task Force Eagle*. Memo for GEN Dennis J. Reimer, etc., Northwestern University, 31 August 1998.

Moskos, Charles. *Short-Term Soldiers*. Washington Post Company, Northwestern University, 13 March 1999.

Murray, Williamson. *Military Culture Does Matter*. Foreign Policy Research Institute, 12 February 1999.

Myers, Steven Lee. *Young People Choosing Fun Over Being All They Can Be*. New York Times, 3 November 1998.

Naegele, Tobias. *The Pay Gap*. Army Times, 9 November 1998.

Newcomb, Curtis L. *Principles of Future Army Force Structure Design*. U.S. Army War College, 20 April 1993.

Newman, Richard J. *Dumbing down the military*. U.S. News & World Report, 23 November 1998.

Office of Economic & Manpower Analysis, Department of Social Sciences. *Unemployment and the DEP & Recruiting*. United States Military Academy Briefing. 14 January 1999.

Office of the Chief of Staff of the Army. *One Team, One Fight, One Future*. 2 December 1998.

Office of the Chief of Staff, Army. *Dynamic Strategic Resource Planning: Toward Properly Resourcing The Army in an Uncertain Environment*. Program Analysis and Evaluation Directorate, Technical Report 97-03.

Office of the Secretary of Defense. *Total Force Integration*. OSD, 2 December 1998.

Ohle, MG David H., Deputy Chief of Staff for Personnel. Personal interview. 12 March 1999.

Ohle, MG David H. *Integration Item 97-19, RC to AC Field Grade Officer Support*. Memo for Reserve Component Coordination Council, 10 July 1998.

Orvis, B.R., Sastry, N.M., & McDonald, L.L. *Military Recruiting Outlook: Recent Trends in Enlistment Propensity and Conversion of Potential Enlisted Supply*. RAND CORP, MR-677-A/OSD, 1996.

Orvis, Bruce, RAND CORP. E-mail interviews. Mid-October 1998 through February 1999.

Parker, Richard. *Keeping Ranks Filled Will Require Money – Or Perhaps Reviving The Draft*. Miami Herald, 27 November 1998.

Parlier, Colonel Greg, Director of Program Analysis & Evaluation, USAREC HQS. Personal interview. 27 January 1999.

Peinhardt, LTC Keith, National Guard Bureau. Personal interview. 29 October 1998.

Peters, Ralph. *NEEDED: 21st – Century Personnel Reform*. Army Times, 5 October 1998.

Pickler, LTG. *AC/RC Integration Item 96-10, Active Component/Army National Guard (AC/ARNG) Integrated Divisions*. Memo for Reserve Component Coordination Council, 9 October 1998.

Pionk, SGM Jerome L, & Barber, MSG Lois M. *United States Army Retention Survey 1997-1998*. HQDA Retention Policy Proponents, 3 November 1998.

Pionk, SGM Jerome L. *Retention: Insert for the Record*. Senate Armed Services committee, Status of Forces, 29 September 1998.

Plewes, MG Thomas J. *Army Reserve: A True Partner in America's Army*. Army Reserve Homepage, 2 December 1998.

Plewes, MG Thomas J. *Barriers to Total Force Integration*. Army Reserve Homepage, 2 December 1998.

Powell, Colin L. *U.S. Forces: Challenges Ahead*. Foreign Affairs, Winter 1992/1993.

Profile of the Army, A Reference Handbook. Institute of Land Warfare, February 1997.

Rains, SGM John, Recruiting Retention Sergeant Major Iowa ARNG. Personal interview. 22 December 1998.

Reefer, COL Vince, Iowa ARNG. E-mail interview. 23 November 1998.

Reimer, GEN Dennis J. *Statement before Senate*. Committee on Armed Services, 105th Cong. 2 session, 29 September 1998.

Reimer, GEN, CSA. *Manning the Force*. CSA99-04 Random Thoughts While Running, 24 February 1999.

Reimer, General Dennis J., CSA. *Remarks on Personnel Readiness*. Briefing, 29 September 1998.

Scarborough, Rowan. *Army Battle to Retain Strength*. Early Bird, 27 January 1999.

Shalikashvili, John. *Joint Vision 2010: America's Military Preparing for Tomorrow*. Washington Quarterly, Summer 1996.

Shubert, Janelle. *Affecting Successful Change in Organizations*. Harvard Lecture, August 1998.

Snider, John, et al. *The Coming Defense Train Wreck and What to do About it*. Washington Quarterly, Winter 1996.

Stone, Andrea. *Good economy is bad news to recruiters*. USA Today, 7 July 1998.

Sullivan, Gordon R. & Harper, Michael V. *Hope is not a Method: What Business Leaders Can Learn From America's Army*. New York: Times Business, 1996.

Technical Report 97-03. *Dynamic Strategic Resource Planning: Toward Properly Resourcing the Army in an Uncertain Environment*. Program Analysis and Evaluation Directorate, Office of the Chief of Staff, Army, the Pentagon, Washington, DC.

The New Book of Knowledge. *U.S. Constitution, Article 1, section 8.11 – 8.15*. Grolier Incorporated, Danbury, CT, 1989.

The View from DCSOPS. Office of the Deputy Chief of Staff for Operations and Plans, Intelligence, Electronic Warfare/C2CM Division, 1995.

Thomas, James R. *Reengineering DoD Recruiting*. RAND Issue Paper, 1997.

Thurman, GEN Maxwell R. *On Being All You Can Be. A Recruiting Perspective*. Future Soldiers and the Quality Imperative: The Army 2010 Conference, December 1994.

Tibbs, LTC. *AC/RC Integration Item 96-14, Associated Unit Concept*. Memo for Reserve Component Coordination Council, 17 July 1998.

Tice, Jim. *1998 Mission Looks Good for Regular Army Recruiters*. Army Times, 25 May 1998.

Tice, Jim. *82,000 Recruited for Army in Fiscal '97*. Army Times, 13 October 1997.

Tipa, COL Ronald J. *Selected Reserve Incentive Programs (SRIP) Policy Guidance for October 1998 for Army National Guard (ARNG) Soldiers (Policy Number 99-1)*. Memo For See DISTRIBUTION, 29 September 1998.

Tipa, COL Ronald, National Guard Bureau. Personal interview. 12 March 1999.

TRADOC-PAM-525-5. *Force XXI Operations: A Concept for the Evolution of Full-Dimensional Operations for the Strategic Army for the Early Twenty-First Century*. TRADOC, Ft. Monroe, Virginia, 1 August 1994.

Unit Positioning and Quality Assessment Model. Information Briefing. USAREC, Ft. Knox, Kentucky, January 1999.

U.S. Army Recruiting Command. *U.S. Army 1998, Pocket Recruiter Guide*. Ft. Knox, Kentucky, 1998.

U.S. Army Recruiting Command Publication Series. Ft. Knox, Kentucky. AC OCT 96. Y NOV 96.

U.S. Army Recruiting Command Regulation 350-6. *Recruiter Production Management System*. Ft. Knox, Kentucky.

U.S. Army Recruiting Command. Personal interviews with numerous staff officers. 10 to 12 March 1999.

U.S. Army Recruiting Command. *Vision and Transformation Strategy*. Ft. Knox, Kentucky, 17 November 1998.

U.S. Army Recruiting Command. Briefing to General Dennis Reimer, CSA, 20 November 1998.

U.S. Army Recruiting Command. Briefing to MG Evan R. Gaddis, 19 February 1999.

U.S. Army Recruiting Command. Production Reports. Ft. Knox, Kentucky, October 1987 to January 1999.

- U.S.Army Recruiting Command. *Recruiting Functional Area Assessment*. Briefing. 15 March, 1999.
- U.S.Army Recruiting Command. *State of the Youth Market*. Briefing. 10 March 1999.
- U.S.Army Recruiting Command Homepage. *History of Army Recruiting*. 15 February 1999.
- Walker, COL, *AC/RC Integration Item 97-34, Army National Guard (ARNG) Fort State Initiative* (Memo for Reserve Component Coordination Council, 15 October 1998).
- Wass de Czege, BG Huba, *Optimizing Future Battle Command Technologies* (Military Review, March-April 1998) 15-21.
- Westcott, COL, *AC/RC Integration Item 97-38, USAR Integration Opportunities in LOGCAP* (Memo for Reserve Component Coordination Council, 15 September 1998).
- Willis, G.E. *Recruiters Allowed to Take Time Off, But Many Do Not*. Army Times, 13 July 1998.
- Wilson, Bennie J. III. *The Guard and Reserve in the Total Force, The First Decade 1973-1983*. National Defense University, May 1985.
- Winkler, John D. *Restructuring the Total Army School system*. RAND CORP, Santa Monica, California, 1996.
- WWW Home Page. United States Army Recruiting Command. Through MSN.COM, November 1998.
- Zirkelbach, COL Mark, Iowa ARNG. E-mail interview. 9 January 1999.