

**FITNESS REQUIREMENTS OF THE 75TH RANGER REGIMENT:
ARE THEY RELEVANT?**

**A thesis presented to the Faculty of the U.S. Army
Command and General Staff College in partial
Fulfillment of the requirements for the degree**

**MASTER OF MILITARY ART AND SCIENCE
General Studies**

by

**MARK LEE WALTERS, MAJ, USA
B.S., United States Military Academy, West Point, New York, 1988**

Fort Leavenworth, Kansas

1999

Approved for public release; distribution is unlimited.

DTIC QUALITY INSPECTED 4

19990909 366

REPORT DOCUMENTATION PAGE

Form Approved
OMB No. 0704-0188

Public reporting burden for this collection of information is estimated to average 1 hour per response, including the time for reviewing instructions, searching existing data sources, gathering and maintaining the data needed, and completing and reviewing the collection of information. Send comments regarding this burden estimate or any other aspect of this collection of information, including suggestions for reducing this burden to Washington Headquarters Services, Directorate for Information Operations and Reports, 1215 Jefferson Davis Highway, Suite 1204, Arlington, VA 22202-4302 and to the Office of Management and Budget, Paperwork Reduction Project (0704-0188), Washington, DC 20503.

1. AGENCY USE ONLY (Leave blank)	2. REPORT DATE 4 Jun 99	3. REPORT TYPE AND DATES COVERED Master's Thesis 7 Aug 98 - 4 Jun 99
----------------------------------	-----------------------------------	--

4. TITLE AND SUBTITLE Fitness Requirements of the 75th Ranger Regiment: Are They Relevant?	5. FUNDING NUMBERS
--	--------------------

6. AUTHOR(S) MAJ Mark Lee Walters	
---	--

7. PERFORMING ORGANIZATION NAME(S) AND ADDRESS(ES) U.S. Army Command and General Staff College ATTN: ATZL-SWD-GD 1 Reynolds Ave., Bldg. 111, Rm. 123 Ft Leavenworth, KS 66027-1352	8. PERFORMING ORGANIZATION REPORT NUMBER
--	--

9. SPONSORING/MONITORING AGENCY NAME(S) AND ADDRESS(ES)	10. SPONSORING/MONITORING
---	---------------------------

11. SUPPLEMENTARY NOTES

12a. DISTRIBUTION/AVAILABILITY STATEMENT Approved for Public release; distribution is unlimited	12b. DISTRIBUTION CODE A
---	--

13. ABSTRACT (Maximum 200 words)

This study investigates the degree to which the individual fitness standards of the 75th Ranger Regiment relate to the physical requirements of combat. Specifically, are the physical parameters that are measured during fitness testing the same physical parameters that are required to perform the physically demanding tasks of combat? The study analyzes the 75th Ranger Regiment's fitness test events in terms of the physical parameters that are measured (e.g., muscular endurance and aerobic power). It then develops a list of the most physically demanding tasks Rangers have performed in combat operations since Operation Urgent Fury in 1983. These tasks are then translated into the physical parameters that were required to perform them. Finally, the two sets of parameters are compared to determine the degree the fitness test events relate to the physically demanding combat tasks. The study concludes with recommendations for changing the individual fitness tests to make them correlate better with the physical requirements of combat.

14 SUBJECT TERMS Physical Fitness Rangers 75th Ranger Regiment APRT	15. NUMBER OF PAGES 76
	16. PRICE CODE

17. SECURITY CLASSIFICATION OF REPORT UNCLASSIFIED	18. SECURITY CLASSIFICATION OF THIS PAGE UNCLASSIFIED	19. SECURITY CLASSIFICATION OF ABSTRACT UNCLASSIFIED	20. LIMITATION OF ABSTRACT UL
--	---	--	---

MASTER OF MILITARY ART AND SCIENCE

THESIS APPROVAL PAGE

Name of Candidate: Major Mark Lee Walters

Thesis Title: Fitness Requirements of the 75th Ranger Regiment: Are They Relevant?

Approved by:

, Thesis Committee Chairman
Major James C. Larsen, M.S.

, Member
Lieutenant Colonel Richard C. Bullis, Ph.D.

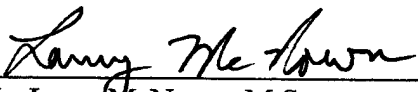
, Member
Mr. Larry McNown, M.S.

Accepted this 4th day of June 1999 by:

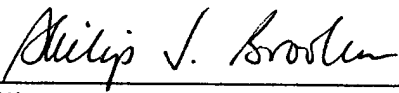
, Director, Graduate Degree Programs
Philip J. Brookes, Ph.D.

The opinions and conclusions expressed herein are those of the student author and do not necessarily represent the views of the U.S. Army Command and General Staff College or any other governmental agency. (References to this study should include the foregoing statement.)

ABSTRACT

FITNESS STANDARDS OF THE 75TH RANGER REGIMENT: ARE THEY RELEVANT? by MAJ Mark Lee Walters, USA, 76 pages

This study investigates the degree to which the individual fitness standards of the 75th Ranger Regiment relate to the physical requirements of combat. Specifically, are the physical parameters that are measured during fitness testing the same physical parameters that are required to perform the physically demanding tasks of combat? The study analyzes the 75th Ranger Regiment's fitness test events in terms of the physical parameters that are measured (e.g., muscular endurance and aerobic power). It then develops a list of the most physically demanding tasks Rangers have performed in combat operations since Operation Urgent Fury in 1983. These tasks are then translated into the physical parameters that were required to perform them. Finally, the two sets of parameters are compared to determine the degree the fitness test events relate to the physically demanding combat tasks. The study concludes with recommendations for changing the individual fitness tests to make them correlate better with the physical requirements of combat.

TABLE OF CONTENTS

	Page
APPROVAL PAGE	ii
ABSTRACT	iii
ACKNOWLEDGMENTS	iv
LIST OF ABBREVIATIONS	vi
LIST OF TABLES.....	viii
CHAPTER	
1. INTRODUCTION.....	1
2. REVIEW OF LITERATURE	10
3. RESEARCH METHODOLOGY.....	32
4. ANALYSIS	36
5. CONCLUSIONS, IMPLICATIONS AND RECOMMENDATIONS....	53
APPENDIX	
A. 75TH RANGER REGIMENT TASK ORGANIZATION	63
B. QUESTIONNAIRE	66
C. ARMY PHYSICAL FITNESS TEST STANDARDS	68
GLOSSARY	71
BIBLIOGRAPHY	72
INITIAL DISTRIBUTION LIST	76

ABBREVIATIONS

APFE	Army Physical Fitness Examination
APFT	Army Physical Fitness Test
APRT	Army Physical Readiness Test
AR	Army Regulation
ARI	Army Research Institute
BET	Battle Efficiency Test
CGSC	Command and General Staff College
CTL	Critical Task List
CWST	Combat Water Survival Test
FM	Field Manual
FTX	Field Training Exercise
JSOTF	Joint Special Operations Task Force
KU	University of Kansas
LBE	Load-Bearing Equipment
METL	Mission Essential Task List
MMAS	Master of Military Art and Science
MOS	Military Occupational Specialty
MOUT	Military Operations in Urban Terrain
NCO	Noncommissioned Officer
PFT	Physical Fitness Test
PT	Physical Training

QRF	Quick Reaction Force
RIP	Ranger Indoctrination Training
ROP	Ranger Orientation Training
RTC	Regimental Training Circular
SMCT	Soldiers' Manual of Common Tasks
STP	Soldiers' Training Pamphlet
TF	Task Force
TRADOC	Training and Doctrine Command
UNOSOM	United Nations Observers Somalia
USAPFU	U.S. Army Physical Fitness Unit

LIST OF ILLUSTRATIONS

Figure	Page
1. Push-up Exercise.....	38
2. Sit-up Exercise.....	38
3. Chin-up Exercise.....	40

LIST OF TABLES

Table	Page
1. Matrix of RIP/ROP Fitness Events.....	17
2. RTC 350-1 Fitness Related Tasks.....	18
3. 75th Ranger Regiment Foot Marching standards.....	18
4. Matrix of 75th Ranger Regiment Individual Fitness Requirements.....	36
5. Fitness Event to Physical Parameter Matrix.....	41
6. General Muscle Groups Measured During Local Muscular Endurance Fitness Events.....	42
7. Combat Experience of Questionnaire Respondents.....	43
8. Physically Demanding Tasks List.....	44
9. Combat Task to Physical Parameter Matrix.....	49
10. General Muscle Groups Measured During Local Muscular Endurance Combat Tasks.....	50
11. Regimental Fitness Events Versus Combat Tasks Physical Parameter Comparison.....	50

CHAPTER 1

INTRODUCTION

Physical conditioning and mental hardness in combat will be a bigger factor than anticipated. After alert, marshaling, mission planning, deployment air flights, and parachute or air assault, Rangers will run or IMT [Individual Movement Technique] significant distances to initial targets, carrying combat loads and then fight. Fighting will last for long periods involving running to new locations, evacuating casualties by litter, moving prisoners, climbing walls, stairs, etc. After initial targets are secured, we must possess the discipline, strength, focus and endurance to face media scrutiny, follow-on operations and security requirements. There will be no immediate AAR tent or time to congratulate ourselves.¹

Colonel Stanley A. McChrystal, Quarterly Training
Guidance--2d Quarter, FY 98

The Problem

The 75th Ranger Regiment is the United States Army's premier light infantry and special operations force. It is equipped with the best soldiers, equipment and resources and is therefore expected to be the best fighting organization in the United States Army. At any time, one of the Regiment's battalions must be prepared to deploy to a conflict within nine hours notice, fight and win. Predictably, as the Regimental Commander has noted, "Operations will be in MOUT [Military Operations in Urban Terrain], at night, in close proximity to noncombatants, and time sensitive. Fighting will be initially confusing (and) extremely physical." Consequently, soldiers assigned to the Regiment cannot expect the luxury of advanced notice before going into combat, they must continually be ready, twenty-four hours a day, seven days a week.

To ensure his Rangers are ready for the physical nature of combat the Ranger leader must be an expert trainer. He must make the most of his time and resources, which

are constrained (despite popular opinion). Further, the training he plans and supervises must be battle focused and apply to the tasks his men will execute in the combat environment. He must adhere to the leaders responsibilities outlined in U.S. Army Field Manual (FM) 25-101, *Battle Focused Training*, in order to ensure their subordinates understand and perform their roles in training.²

One leader responsibility is to “demand training standards be achieved.”³ The leader will always train his men to an established standard in order to provide direction and purpose for the training. Therefore, when a leader develops a training plan he must also ensure the standard is not only realistic, but is relevant to the task. Otherwise, he wastes valuable time and effort. This principle applies in all aspects of training, from classroom activities to field training exercises (FTXs).

In the area of physical fitness, the fitness standards leaders expect their men to achieve must be relevant to the tasks that they will perform in battle. FM 21-20, *Physical Fitness Training*, instructs commanders to “regularly measure the physical fitness level of every soldier to evaluate his progress and determine the success of the unit’s program.”⁴ The standards that leaders use to evaluate their men’s performance must be measurable and applicable.

Likewise, the 75th Ranger Regiment evaluates its soldiers against specific physical fitness standards outlined in the Regimental Training Circular (RTC) 350-1. These standardized events include the Army Physical Fitness Test, chin ups, five-mile run and a twelve-mile road march with combat gear, to include a rucksack weighing forty-five pounds.⁵ The question, however, is how relevant are these events to the battle tasks that

Rangers may perform in combat. Are these tests appropriate or should they be more specific and focused, like all other training events and corresponding standards?

The Research Question

This paper will focus on the 75th Ranger Regiment's physical fitness standards. Specifically, the following research question will be answered: To what extent do the current 75th Ranger Regimental physical fitness standards relate to the physically demanding tasks that a Ranger must be able to perform in combat? In concert with this central question are five related questions that must be answered:

1. What are the physical requirements for service in the 75th Ranger Regiment?
2. What components of fitness and muscle groups are used when performing these tasks?
3. What are the physically demanding tasks that Rangers are expected to perform in combat?
4. What components of fitness and muscle groups are used when performing these combat tasks?
5. If the current test does not adequately relate, how should the current fitness test events be adjusted to measure the Ranger's ability to perform his critical individual tasks?

Assumptions

Before answering these questions, several assumptions must be made in order to frame the analysis. These assumptions combined with the facts derived during the literature review will provide a basis for the hypothesis. These assumptions, according to FM 101-5, *Staff Organizations and Operations*, "take the place of necessary, but

unavailable, facts and fill the gaps in what the commander and staff know about the situation.”⁶

First, this study assumes that all Rangers assigned to the 75th Ranger Regiment can achieve the current minimum standards outlined in RTC 350-1 and, therefore, share the same fitness baseline. This assumption is valid because each Ranger must perform these events to standard in order to earn admission into the Regiment. Further, it is necessary to have a starting point from which to evaluate and build upon the current standards.

Second, the energy or strength required of rifle platoon members to perform their physically demanding tasks is not measurably different from that required by soldiers of differing Military Occupational Specialties (MOSs) (e.g., mortar man). This assumption is valid because, with the exception of a few specific tasks, all Rangers exert the same amount of physical energy to perform their tasks. Additionally, most of the Rangers assigned to the battalions are members of rifle platoons (appendix A). The assumption is necessary because the fitness standards within the Regiment should be universal for simplicity.

Third, each Ranger Battalion possesses the same resources for physical training and testing (e.g., ropes, pull-up bars, etc.) within their battalion area or on their respective installation. Currently this assumption is a fact, but for future reference this will remain an assumption. In the event the required fitness events are adjusted, each battalion must be able to support the test with existing equipment.

Finally, the physical conditions that Rangers faced in past operations (e.g., Urgent Fury and Just Cause) will apply to future combat operations. For example, if the average

weight that a Ranger carried in Operation Just Cause was X pounds, then he can expect to carry X pounds in future operations. This assumption will be validated through the literature review of past combat experiences of the 75th Ranger Regiment. The assumption is also necessary because the information derived will be an essential element in evaluating the current and recommended fitness standards.

Research Methodology

This paper compares physical fitness events against physically demanding individual tasks that Rangers perform. The research will be conducted in two phases. First, each task measured during Regimental fitness tests will be identified and translated into physical parameters and major muscle groups required. Next, through a literature review, interviews of former and serving Ranger Regiment and battalion members, and related studies the research will identify the critical combat tasks performed by Rangers and the corresponding physically demanding tasks. These tasks, in turn, will be translated into the physical parameters and muscle groups required to perform them. The two lists of parameters and muscle groups will be compared, and conclusions will be drawn to determine the extent that the tests meet the combat requirements.

Finally, based on the analysis and conclusions, if the existing tests do not adequately measure the Ranger's ability to physically perform his individual tasks, then recommendations will be made for possible alternatives or additions to the Regimental fitness test events. Implications and conclusions will be drawn and discussed in the final portion of the paper.

Key Definitions

Kinesiology. Kinesiology is the study of muscles and their movements. This study will apply the science of kinesiology to determine what muscle systems and fitness factors are involved when Rangers performs specific functions.

Physical Fitness. For the purpose of this study, physical fitness is defined as the ability to function effectively in physical work, training and other activities and still possess enough energy to handle other emergencies that may arise. This overall ability to function can be further broken down into separate physical components or parameters which include the following:

1. Muscular Strength
2. Local Muscular Endurance
3. Aerobic Power
4. Anaerobic Power
5. Agility
6. Speed

These components of fitness, defined in the thesis' glossary, are the components that the study will examine when relating physical tasks to physical parameters.

Physically Demanding Combat Battle Tasks. This study will determine the physically demanding tasks that Rangers perform in combat. For the purpose of this study any task that requires the Ranger to utilize one of the physical fitness parameters described earlier will constitute a physically demanding task.

Limitations

This study is limited to examining the Regiment's fitness events against the physically demanding tasks required of a rifle platoon member whose MOS is 11B. There are many other soldiers assigned to the 75th Ranger Regiment with varying MOSs, but examining the standards against the rifle platoon member's individual tasks can serve as an adequate foundation for the entire Regiment.

Additionally, this study will only answer the questions through deductive reasoning and will require further scientific analysis to determine specific standards if the current standard should be altered. This paper is primarily concerned with the nature of the specific events and not the respective minimum and maximum standards. Identifying the performance standards would require detailed testing outside the scope of this study.

Finally, gaps may exist in the research with respect to identifying the most physically demanding tasks required of Rangers. Again, the research and subsequent analysis will be based on historical review and interviews with former soldiers who fought in combat with the Ranger Regiment or one of its subordinate battalions. Unfortunately, opinions may outnumber facts and the ability to strictly define a specific number of tasks is difficult. However, this paper will attempt to provide a complete and thorough review and establish common ideas from the sources.

Delimitations

This research will enforce several delimitations in order to provide focus for the research. These delimitations have been thoroughly considered and should not detract from the value of the paper but they are worth noting.

First, this study will not examine or evaluate individual tasks performed by Rangers in combat before Operation Urgent Fury. While United States Army Ranger units have been in existence for hundreds of years and have participated in numerous combat operations before 1983, the Ranger Regiment today is much different. The technological improvements enjoyed by the soldiers today have changed the face of warfare and the tasks they perform.

Second, the study will not conduct an exhaustive review of exercise physiology or kinesiology. The author is not an expert on these topics but is attempting to translate and apply limited the information with the aid of related studies and assistance from physiology experts.

Finally, this study will not address the Combat Water Survival Test requirement (CWST). This event is both a physical fitness and ability test. The test is designed to determine the Ranger's swimming proficiency and is often a measure of ability as well as strength. Therefore, the CWST is outside the scope of this study.⁷

Summary

This study will determine how relevant the 75th Ranger Regimental fitness events are to the actual tasks Rangers will perform in combat. It will examine, in detail the 75th Ranger Regiment physical fitness test events, and identify and evaluate the physically demanding tasks that Rangers perform in combat. Afterward, each task list will be translated into the components of fitness required to perform them. Finally, the two lists will be compared, conclusions will be drawn and recommendations will be made, as required.

¹Stanley F. McChrystal, "75th Ranger Regiment Quarterly Training Guidance--2d Quarter FY 98" (Fort Benning, GA: Headquarters, 75th Ranger Regiment, October 1997), 1.

²US Department of the Army, FM 25-101, *Battle Focused Training* (Washington, DC: Department of the Army, 1990), 1-2.

³*Ibid.*, 1-3.

⁴US Department of the Army, FM 21-20, *Physical Fitness Training* (Washington, DC: Department of the Army, 1992), 1-2.

⁵Headquarters, 75th Ranger Regiment, RTC 350-1, *Training* (Fort Benning, GA: 75th Ranger Regiment, 1998), O-3.

⁶Department of the Army, FM 101-5, *Staff Organization and Operations* (Washington, DC: Department of the Army, 1997), 5-7.

⁷RTC 350-1, O-2.

CHAPTER 2

LITERATURE REVIEW

Tough, demanding, and dynamic physical training is the hallmark of Ranger Training philosophy. Leaders at all levels integrate physical conditioning into all facets of individual and collective training.¹

75th Ranger Regiment, RTC 350-1, *Training*

Introduction

The purpose of this literature review is to provide a theoretical foundation of information and data from which the research will be built. Specifically, it will summarize and evaluate the existing work performed in the area of physical fitness relationships with corresponding combat tasks. The chapter will be divided into three parts: Physical Fitness references, Combat Tasks references, and references that examine the correlation between the two.

The Physical Fitness section will provide a general overview of exercise physiology and kinesiology in order to identify the components of fitness. Next it will examine the United States Army physical fitness doctrine and then the 75th Ranger Regimental fitness requirements and standards.

The Combat Task section will identify the sources that the 75th Ranger Regiment uses to develop its list of critical individual tasks. These are tasks that every Ranger should be able to perform to a specific standard. Afterwards, a review of past combat operations, since 1983, will provide insight into the types of critical individual tasks Rangers performed in combat.

The final section, Individual Task and Physical Requirements Correlation will identify and review previous studies that have been conducted to determine the level each

individual task is physically demanding. These studies were not specifically designed for the Ranger, but rather provided the United States Army criteria to evaluate the soldier's ability to perform in a specific MOS.

Physical Fitness References

General Exercise Physiology and Kinesiology Literature

Among the numerous sources of information concerning Exercise Physiology, one popular academic text is the *Essentials of Strength Training and Conditioning* edited by Thomas R Baechle, Ed.D., and published by the National Strength and Conditioning Association. This book is primarily written for strength and conditioning professionals and students and devotes several chapters to athletic testing and evaluation.

According to Dr. Baechle, the purpose of physical tests are to provide strength and conditioning professionals with a means of assessing athletic talent and identifying specific weaknesses as well as serving as a basis for developing exercise programs.² It outlines the parameters of physical fitness that physical testing should include. These parameters are muscular strength, local muscular endurance, aerobic power, anaerobic power, agility, speed, flexibility, body composition, and anthropometry.³ (These terms are defined in the glossary.)

The subsequent chapters describe the criteria for selecting appropriate tests and proper conduct of testing. The three most important characteristics of the physical fitness test are validity, reliability, and objectivity. If the fitness test does not fulfill these three criteria then it will not produce acceptable measurements for evaluation.⁴

The validity of the test refers to the degree in which the test measures what it was intended to measure. The validity of a test comes in various forms but the most important type of test validity to the strength and conditioning specialist is the *construct validity*.⁵

The construct validity is the degree to which the test measures some part of a whole skill or an abstract trait.⁶ Thus, in order to measure the Ranger's ability to perform his skills the physical fitness test must represent the tasks he performs as part of his job.

The reliability of the test refers to the degree of consistency which the test measures what it is supposed to measure. In other words, it is the degree to which the test can be repeated with minimal variance. For example, the 1.5 mile run is considered the optimal distance to measure cardiovascular fitness but is only reliable for a group of "mature" athletes. If, however, the test were administered to high school tennis players, for example, the test would not be reliable due to their physical maturity factors.⁷

The objectivity of the test refers to the degree in which multiple scorers agree on the magnitude of scores.⁸ This is a classic problem when grading the push-up or sit-up events on the Army Physical Fitness Test. Often, some graders are more lenient toward a soldier performing the event and allow him to get credit for a repetition that was not performed in accordance with the standards outlined in the Field Manual 21-20, *Physical Fitness Training*. In the end, the objectivity of the test is sacrificed.

Finally, *Essentials of Strength Training and Conditioning* offers guidance for developing the athletic profile to determine sport-specific fitness requirements for the athlete. If the soldier, serving in the Ranger Regiment is considered an athlete, then a profile can be established for him, as well. The evaluator can select test events that measure the specific fitness parameters most characteristic of his "sport." Additionally,

the text recommends selecting valid and reliable tests to measure the parameters and to arrange them in an appropriate manner to promote test reliability.⁹

United States Army Physical Fitness Literature

When comparing the U.S. Army and 75th Ranger Regiment physical fitness philosophies to Dr. Baechle's work, there are some interesting differences that this study will consider during the course of the evaluation. For the purpose of this thesis, the research will focus on three U.S. Army documents relating to fitness: Army Regulation (AR) 350-41, *Training In Units*; FM 21-20, *Physical Fitness Training*; and FM 21-18, *Foot Marches*. Concerning the 75th Ranger Regiment, the RTC 350-1 and specific policy letters outline the requirements for physical fitness. Interviews with previous Ranger leaders will provide some historical information and logic for the design of the test events and standards.

Army Regulation 350-41, *Training in Units*, discusses and directs the physical fitness training policy and procedures that all U.S. Army units will adhere to when developing programs and measuring performance. Specifically, it requires all soldiers to pass the APFT twice a year. Accordingly, this test is designed to measure upper and lower body muscular and cardiorespiratory endurance and to serve as a performance test, indicating a soldier's ability to perform physically and handle his body weight. The regulation further explains that the intent of the APFT is to "provide an assessment of the physical fitness training program . . . designed to ensure the maintenance of a base level of physical fitness essential for every soldier in the Army, regardless of Military Occupational Specialty (MOS) or duty assignment."¹⁰

The AR 350-1 stipulates that the APFT will not form the foundation of unit or individual fitness programs, but only serves as one part of a total fitness program.¹¹ The regulation directs that preparation for the APFT will not become more important than programs designed to “enhance the soldier’s ability to complete critical soldier or leader tasks that support the unit’s METL [Mission Essential Task List].”¹²

In consonance with the AR 350-1, FM 21-20, *Physical Fitness Training*, provides the physical fitness doctrine that all commanders and leaders will follow. FM 21-20 describes in detail components of fitness and nutrition and provides recommendations and guidance for developing unit fitness programs to enhance and improve soldiers’ fitness levels and units’ performance.

The manual describes the components of fitness as cardiorespiratory endurance, muscular strength, muscular endurance, flexibility, and body composition. It does not include, however, other factors, such as speed, agility, and power within this group of components, but describes them as components of “motor fitness.” The goal of the Army’s total fitness program is to maintain or improve both sets of components.¹³ Chapter 3 of FM 21-20 discusses the principle of muscular fitness, describing the relationship between its two components, strength and endurance. By definition, muscular strength is the greatest amount of force a muscle or group of muscles can exert in a single effort. Muscular endurance is the ability of the muscle or group to perform repeated contractions against a less than maximum resistance for a period of time. While they are separate components, they are related because “progressively working against resistance will produce gains in both these components.”¹⁴ Thus, a measurement of muscular endurance will also provide feedback for muscular strength.

Chapter 14 describes the APFT in complete detail, to include instructions for its administration. This test is comprised of three events performed in sequence. First, the soldier performs the push-ups within a two-minute time limit. After a break, not to exceed ten minutes, he then performs the bent knee sit-ups within a two-minute limit. Finally, within ten minutes of completing the sit-up event, he runs two miles on a measured course for time. Each of these events have established minimum and maximum standards of performance which are outlined in appendix C.

In the introduction, the chapter states, "performance on the APFT is strongly linked to the soldier's fitness level and his ability to do fitness-related tasks."¹⁵ It continues to advise commanders to use their unit's APFT results to measure its physical fitness level, albeit with the caution that mission-essential tasks should "drive physical training."¹⁶

It is interesting to note that in earlier editions of FM 21-20 (before the 1986) the APFT was known as the Army Physical Readiness Test (APRT) which proposed to measure the basic components of physical *readiness* and evaluate the soldier's ability to perform his assigned tasks.¹⁷ The events were the same as they are today, but leaders believed it was an indicator of *readiness* instead of *fitness*; that is, not directly related to performance of assigned tasks.

Before 1980, the United States Army measured physical fitness with the five-event Army Physical Fitness Examination (APFE). These five events were designed to measure "the basic components of physical fitness to include endurance, agility, coordination and strength (including explosive power)."¹⁸ Moreover, the tests were designed to evaluate an individual's physical ability to perform assigned physical tasks.

The United States Army also publishes doctrine concerning foot marching through FM 21-18, *Foot Marches*. Like FM 21-20, the *Foot Marches* manual provides guidelines for the successful conduct and training of foot marches in order to maximize performance and minimize injury.

Typically, as will be observed through historical review, today's Ranger deploys to combat with very little outside support. In other words, he lives with what he carries in his rucksack, so training to fight with heavy loads is a realistic requirement. FM 21-18 provides specific and scientific guidance for tailoring and training with heavy loads that should be addressed when developing road march training and testing.

75th Ranger Regiment Physical Fitness Literature

The 75th Ranger Regiment provides specific guidance for testing and standards in all aspects of training, to include physical fitness in their RTC 350-1, *Training*. This document is the single source for all standardized training issues within the Regiment, from collective to individual level. The specific requirements for physical fitness are outlined throughout the document.

Chapter 7, "Regimental Individual Training," begins by outlining the physical requirements for service in the Regiment. It states that every Ranger is required to pass the APFT semiannually each year to a standard of 240 points, with 80 points in each event. Additionally, the Ranger must complete a minimum of six chin-ups (palms facing in).¹⁹

When a Ranger is under consideration for assignment into the Ranger Regiment he attends a two-week orientation course designed to teach the Ranger about the 75th Ranger Regiment's history and standard operating procedures and to determine if he can

meet the standards required for service. Officers and noncommissioned officers attend the Ranger Orientation Program (ROP) and enlisted Rangers attend the Ranger Initiation Program (RIP). During both RIP and ROP the Ranger candidates are tested in the tasks outlined in Table 1.²⁰

Table 1. Matrix of RIP/ROP Fitness Events

Event	Conditions	Time Limit
Push-ups	PT Uniform	Two minutes
Sit-ups	PT Uniform	Two minutes
2 mile run	PT Uniform	none
Chin-up	PT Uniform	No time limit
5 mile run	PT Uniform, in unit formation	Within 40 minutes
12 mile road march	BDUs, combat gear w/ 45lb. Field pack	Within 3 hours

Once the Ranger has passed his RIP/ROP and is a member of the Regiment, he must maintain the physical standards outlined in RTC 350-1, Chapter 11, "Physical Fitness Training." The Regimental Training Requirements Matrix, located in Appendix O of the RTC 350-1, also outlines the tasks, frequency, and standards for all recurring training requirements. The fitness related tasks are described in Table 2.²¹

Finally, the Regimental Commander's Policy Statement 20 (Foot March Standard) directs that every Ranger will conduct a twenty- or thirty-mile foot march quarterly, alternating quarters between the two distances. During the twenty-mile foot march the Ranger carries a combat load to include a fifty-pound field pack (e.g., rucksack).

Similarly, during the thirty-mile foot march the Ranger carries a combat load with a thirty-pound assault pack.²² Table 3 provides a matrix of those foot march tasks outlined in the policy statement.

Table 2. RTC 350-1 Fitness Related Tasks

Task	Frequency	Remarks
APFT w/ 6 chin-ups	Semiannually	APFT = pushups, sit-ups and two mile run
5 mile run	One time per quarter	Unit formation run, completed NLT 40 minutes (8 min/mil +/- 15 seconds)
Foot march	Weekly / once per quarter	Standards in accordance with Regimental Policy Letter 20

Table 3. Regimental Foot Marching Standards

Distance	Frequency	Uniform	Time Standard
10 miles	Weekly	Varies with Battalions, usually PT uniform with boots and LBE	Varies with Battalions, usually 2 hrs.
20 miles	Once per quarter	BDUs, Kevlar, weapon, LCE and FIELD pack, 50 lbs.	None. Prepared to transition to combat operations
30 miles	Once per quarter (alternates with 20 mile)	BDUs, Kevlar helmet, weapon, LCE and Assault pack, 30 lbs.	Same as the 20-mile foot march

There is no set time standard for the twenty- and thirty-mile foot marches. The requirement, however, is that every Ranger should be capable of transitioning to combat operations at the conclusion of the movement. The focus is not on speed but on stamina.

In summary, the physical events that Rangers must perform as part of the Regimental Fitness standards are the following:

1. Push-ups, within a two minute period
2. Sit-ups, within a two minute period
3. Two-mile run for time
4. Chin-ups, minimum of six repetitions
5. Five-mile run, within forty minutes at an eight-minute mile pace, plus or minus fifteen seconds per mile
6. Foot march, between ten, twenty, and thirty miles in length, carrying between thirty and fifty pounds

Ranger Combat Tasks Literature

United States Army and 75th Ranger Regiment Training Documents

Like all United States Army units, the 75th Ranger Regiment and its battalions and companies train using a METL. The purpose of the METL is to allow commanders to identify the tasks they believe are essential to accomplishing the unit's wartime mission. Once these tasks are identified, then the commander can focus his training efforts and resources.²³

The METL is the bedrock of the United States Army's training doctrine and is discussed in detail in two manuals, FM 25-100, *Training the Force* and FM 25-101, *Battle Focused Training*. These manuals provide the necessary information to assist leaders with developing the training strategies necessary to maximize performance.

The 75th Ranger Regiment outlines its METL in RTC 350-1, *Training*. The Battalions, likewise, develop their METL based on the Regimental METL, just as the rifle

companies draw their METL from the Battalion METL. Finally, each rifle platoon develops a list of critical collective tasks from the rifle-company METL.²⁴

With respect to individual tasks that Rangers perform as part of their collective mission essential tasks, the Regiment has produced a list of Critical Individual Tasks. This list outlines tasks, with references, for all MOSs represented within the 75th Ranger Regiment.²⁵ Part of the research and analysis will evaluate some of these tasks to determine the physical parameters required to perform them.

The 75th Ranger Regimental METL and Critical Individual Task list provides a starting point to evaluate which tasks are physically demanding. Once the base list is identified, then the research can examine what tasks were performed in combat operations and which of those tasks, if any, were physically demanding.

Review of Ranger Combat Operations

This portion of the literature review will summarize the combat operations that Rangers have participated in since the formation of 1st and 2nd Battalions in 1974. These summaries, drawn from books, articles, and interviews, will provide the database of tasks that Rangers performed during these operations.

Operation Urgent Fury (Grenada)

On 25 October 1983 the 1st and 2nd Ranger Battalions led the invasion of the island of Grenada during Operation Urgent Fury. Mark Adkin's book *Urgent Fury: The Battle for Grenada* and John Locke's *To Fight With Intrepidity: The Complete History of the U.S. Army Rangers 1622 to Present* provide thorough reviews of the operation. Additionally, they point out the lessons that the Rangers learned in their first experience in combat as battalions since World War II.

The 1st and 2nd Ranger Battalions conducted an airborne assault and seized Point Salines Airfield, on the southern end of the island. During this first mission, platoons and companies conducted attacks against enemy strongpoints in order to secure the lodgment area and clear the runway of debris for follow-on airland forces. Additionally, the Rangers secured the True Blue Medical Campus where American medical students were held. The next day, 26 October, 2nd Battalion conducted an air assault raid and seized Grand Anse Campus where more Americans required evacuation. Finally, on 27 October the 2nd Battalion conducted another air assault raid to secure Calvigny Barracks, a known Cuban training camp. While no enemy forces were found on the objective, the battalion of Rangers performed the operation to the standard required of a battalion assault in a built-up area.

The Ranger Battalions learned numerous lessons during this operation about the physical requirements of combat. Most notably, as Mark Adkin points out, many of the Rangers were overloaded with unnecessary equipment due to uncertainty on the part of leaders and the lack of combat experience by all participants.²⁶

Physically speaking, this operation could be characterized as a short operation, only lasting less than one week. The combat tasks were initially very intense requiring Rangers to move quickly, carrying heavy loads, under direct and indirect fires. In some instances, the Rangers were required to move heavy equipment off of the runway to allow the follow-on aircraft to land, then download other equipment (e.g., ammunition) from the aircraft. After the initial airborne assault, all of the subsequent missions were by air assault, allowing the Rangers to conserve their energy for the actual assault on the objective. Finally, it should be noted, that both battalions conducted reconnaissance and

security patrols in their areas of operations; a task that required the Ranger to walk long distances with a combat load.

Operation Just Cause (Panama)

The next operation the Rangers would participate in was on 20 December 1989 when the entire Regiment led the invasion of Panama during Operation Just Cause. In their book *Operation Just Cause: The Storming of Panama*, Thomas Donnelly, Margaret Roth and Caleb Baker provide a detailed account of the entire operation from initial buildup to the final surrender of General Manuel Noriega. The authors point out that some of the Rangers had learned lessons from Grenada concerning soldier's load and carried lighter loads while others were burdened with ruck sacks that weighed approximately 80 pounds. In one case, an NCO had to have his rucksack "carried to the plane by two jumpmasters; he could not carry it himself and his parachute."²⁷

For the Rangers' part in Operation Just Cause, 1st Battalion and C Company from 3rd Battalion conducted the initial airborne assault to seize Tocumen Military Airfield Complex and Omar Torrijos International Airport in Panama City. Simultaneously, 2nd Battalion and 3rd Battalion (-) conducted an airborne assault to seize Rio Hato Military Airbase, approximately sixty miles north of Panama City. Just as in Operation Urgent Fury, Rangers conducted subsequent assaults to seize critical objectives in and around their respective airfields in order to destroy enemy forces or clear the runway for follow on airland operations. These missions were conducted in predominantly complex urban terrain around the airport and enemy barracks. On 25 December, 3rd Battalion conducted an air assault raid against the last organized resistance in the town of David. Finally, on 28 December two companies from 3rd Battalion performed an air assault raid to round up

loose criminals and enemy sympathizers who escaped the Camp Machete Prison complex. Throughout the remainder of the operation each battalion conducted patrolling and security operations until they redeployed on 9 and 10 January 1990.²⁸

With respect to the physical nature of Operation Just Cause, it was similar to Operation Urgent Fury. At times the combat was very intense requiring the Rangers to maneuver under direct fire in urban areas and heavy vegetation. They often conducted casualty evacuation and ammunition resupply; lifting and carrying heavy loads over long distances. Once their initial objectives were accomplished however, the Rangers continued to conduct patrols throughout their areas of operation, requiring long foot movements through varied terrain.

Operation Desert Shield and Desert Storm

The majority of the 75th Ranger Regiment did not deploy to the Persian Gulf during Operations Desert Shield and Storm, but instead served as the United States Army's strategic reserve. One reinforced company from 1st Battalion, however, deployed to Saudi Arabia and performed force protection operations for the Joint Special Operations Task Force (JSOTF) compound, during Desert Shield. Once the ground war began, the company conducted an air assault raid and destroyed an Iraqi radio relay tower. On 6 April 1991 the company redeployed to their home station in Savannah, Georgia.²⁹

Since this was a single operation on an objective without enemy it was not particularly physically difficult. However, once on the ground the Rangers treated the mission like any other and moved quickly, negotiated obstacles and carried combat loads.

Operation Restore Hope (UNOSOM II)

On 26 August 1993 B Company, 3rd Ranger Battalion deployed to Somalia as part of TF Ranger. Their task was to support the capture of the Somali warlord, Mohamed Farrah Aidid and his top lieutenants, in conjunction with other elements from the United States Army Special Operations Command. These operations were primarily air assault raids designed to quickly surprise and capture the targets before the enemy could mass a force to stop them.

These missions were met with mixed results but were always conducted before enemy or crowds could interdict their efforts. Unfortunately, on 3 October, the TF Ranger air assault raid ended in failure when Aidid sympathizers reacted before the force could extract. The ensuing eighteen-hour battle was essentially a "running gun fight" down the streets of Mogadishu for the Rangers as they attempted to break contact with the masses of armed Somalis. Eventually, the Quick Reaction Force (QRF) was able to link up with the Rangers and get them back to safety.³⁰

For the Rangers on the ground, this operation was probably the most physically demanding one in recent history. As these men fought for their lives, they literally exhausted themselves carrying wounded, negotiating obstacles throughout the urban terrain, and moving under the direct fire of the enemy all while carrying 40 pound body armor, in addition to their standard combat load.

Operation Uphold Democracy

The most recent operation that Rangers participated in was Operation Uphold Democracy in Haiti in September 1994. Originally planned as a combat operation, it became a stability and support mission when the enemy leader, General Cedras agreed to

step down and dismantle his armed forces. Afterwards, 2nd Battalion provided the only Ranger role when they performed security operations around the island in support of Special Forces teams. Most of the tasks involved patrolling the city streets, establishing road blocks to check cars for weapons, and arresting suspected Cedras supporters. On one occasion the battalion conducted an assault to clear enemy sympathizers from two local hotels.³¹

Summary

This segment of the literature review was intended to give an overview of the combat operations that Rangers have participated in since the 1st and 2nd Ranger Battalions were formed in 1974. These summaries provide a general concept of the types of missions and tasks that individual Rangers performed. Follow-up interviews with Rangers who took part in these operations will provide specific examples of physically demanding tasks that they performed.

Fitness and Combat Task Correlation Studies

The Army's physical fitness test is a normative standards based test, designed to identify the general fitness level of all soldiers regardless of duty position. Additionally, the test can be administered anywhere in the world since it does not require any outside resources (e.g., pull-up bars or run, dodge, and jump apparatus).³² The United States Army, however, has sponsored numerous studies to assess the physical demands of MOSs in order to ensure initial entry soldiers are correctly placed in positions that are physically demanding.

To that end, the Army publishes a general list of physically demanding tasks performed by infantryman in AR 611-201, *Military Occupational Structure and*

Classification. This list describes the typical physical demands for each MOS and skill level (e.g., 11B10 is Infantry Rifleman, Specialist and below) and is used to serve as the standard for selecting soldiers who are physically qualified for duty as Infantrymen.³³

The process to determine the physical demands outlined in AR 611-201 was developed by the U.S. Army Training and Doctrine Command (TRADOC) and the U.S. Army Research Institute (ARI). This joint study, *Assessing the Physical Demands and Direct Combat Probability of United States Army Organizations, Military Occupational Specialties and Duty Positions*, published in 1980, identified the physically demanding tasks and individual requirements that comprise each MOS. The endstate was a database of the physical demands found within each of six physical job categories (i.e. lifting/lowering, lift and carry, climbing, digging, walking/marching, and pushing/pulling) that made up all enlisted military occupational specialties.³⁴

In order to build this database, the researchers developed a model based on a scientific evaluation of a large sample of soldiers. The evaluator examined and interviewed soldiers performing work over a period of time and selected the physically demanding tasks that were being performed from a standard list of twenty-two factors. This model further rated the level of work (e.g., light, medium, and heavy) to provide more distinction between other MOS requirements.³⁵

The physical requirements determined from this model are now used to screen new recruits for potential service in an MOS and for final qualification before completing their respective Advanced Individual Training (AIT) and joining their unit.³⁶ Yet, this type of study has not been performed to determine qualification for service into specific organizations such as the 75th Ranger Regiment.

Arguably this methodology should work well for determining the physical qualifications for service in the Regiment. Unfortunately, this research does not allow the time or subject availability for a detailed analysis of performance. The method best suited, however, is through a qualitative evaluation of the tasks drawn from literary review and interviews that will be discussed in more detail in the following chapters.

In addition to the United States Army's research, in 1985 the Canadian Forces sponsored a study to evaluate its Battle Efficiency Test (BET). The BET, consisting of two 16 kilometer (km) forced marches in full fighting gear, conducted over two consecutive days, was commonly believed to measure the aerobic power (known as VO₂max) and the endurance capacity of the soldier. The study, however, concluded that it did not measure either of these physical parameters, but was still a good test to measure "one infantry function." The study further concluded the need for a more "global index of the soldier's ability to meet the physical demands of his job."³⁷

This research is interesting and demonstrates the need to determine what that "global index" should be. Unfortunately, the scope was limited to determining what the BET measured and not how it related to combat requirements.

More recently, in 1992 Major John E. McLean II published a Master of Military Art and Science thesis that examined if the tasks measured by the United States Marine Corps physical fitness test (PFT) adequately assess the fitness needs of Marines in an amphibious assault. In his study, he outlined the physically demanding tasks that Marines performed when executing an amphibious assault operation. Afterward, he determined that the obstacle course and swim tests that all Marines conduct in their basic courses best correlated with the physical tasks identified. Next, he took the scores from those tests and

compared them to the PFT scores, by the same sample of Marines. Through statistical analysis he surmised that there was a poor correlation between performance on the PFT and performance on the obstacle and swim tests. He concluded that the current Marine PFT was not an adequate indicator of a Marine's ability to perform an amphibious assault operation.³⁸

This study is an excellent example of using statistical analysis to determine more concrete results. Major McLean, however, had the advantage using the results of an existing test (obstacle course and swim test) that replicated the tasks performed in combat. These results were relatively easy to obtain and subsequently analyzed for his conclusions. Unfortunately, the 75th Ranger Regiment does not administer other measurable tests that replicate the physical requirements of combat, so "scores" are not available to analyze and compare with the fitness requirements.

At the same time, Major McLean's analysis was limited to one type of operation that Marines perform. He admits in his "Introduction" that he is not considering combat operations after the amphibious assault or actions taken during the unload period of an amphibious operation.³⁹ This study, however, is considering all the aspects of combat that Rangers may participate in. Consequently, it is more difficult to determine those tasks without the "expert" advice of those who have been in combat.

Summary

The literature review shows that the APFT does not assess a soldier's ability to perform his combat tasks. Attempts have been made to ensure "physically qualified" soldiers are placed in the right jobs upon accession, but there are no specific tests to ensure he remains physically "battle ready." The same may be said for the 75th Ranger

Regiment. While the physical fitness standards are far and above the Army standard, no studies have been conducted to correlate their tests to physical requirements in combat.

At this writing, however, the 75th Ranger Regiment is conducting tests to develop a test that is more "combat focused." These results have not been formalized and will only be addressed during the Discussion Chapter of the paper.

Again, this study's goal is to determine if there is truly a disconnect between the Regiment's fitness tests and requirements and the actual requirements that Rangers will face in combat.

¹Headquarters, 75th Ranger Regiment, RTC 350-1, Training (Fort Benning, GA: 75th Ranger Regiment, 1998), 7-1.

²Thomas R. Baechle, *Essentials in Strength Training and Conditioning*, ed. Thomas R. Baechle, Ed.D., CSCS (Omaha, NE: National Strength and Conditioning Association, 1994), 247.

³Ibid., 248.

⁴Ibid., 250.

⁵Ibid.

⁶Ibid.

⁷Ibid., 251.

⁸Ibid.

⁹Ibid., 278.

¹⁰Department of the Army, AR 350-41, *Training in Units* (Washington, DC: Department of the Army, 1993), 17.

¹¹Ibid.

¹²Ibid., 16.

¹³Department of the Army, FM 21-20, *Physical Fitness Training* (Washington, DC: Department of the Army, 1992), 1-3 and 1-4.

¹⁴*Ibid.*, 3-1.

¹⁵*Ibid.*, 14-1.

¹⁶*Ibid.*

¹⁷Department of the Army, FM 21-20, *Physical Fitness Training* (Washington, DC: Department of the Army, 1980), E-1.

¹⁸Department of the Army, FM 21-20, *Physical Fitness Training* (Washington, DC: Department of the Army, 1973), 220

¹⁹Headquarters, 75th Ranger Regiment, RTC 350-1, *Training* (Fort Benning, GA: 75th Ranger Regiment, 1998), 7-1-7-6.

²⁰Headquarters, 75th Ranger Regiment, Memorandum, Ranger Indoctrination Program Memorandum of Instruction (Fort Benning, GA: Headquarters, 75th Ranger Regiment, 4 February 1999), 1.

²¹RTC 350-1, O-2.

²²Headquarters, 75th Ranger Regiment, Memorandum, "Regimental Commander's Policy Statement 20" (Foot March Standard) (Fort Benning, GA: Headquarters, 75th Ranger Regiment, 1 September 1997), 1-2.

²³Department of the Army, FM 25-100, *Training the Force* (Washington, DC: Department of the Army, 1988), 2-1.

²⁴RTC 350-1, 2-1.

²⁵Headquarters, 75th Ranger Regiment, Memorandum, 75th Ranger Regiment Critical Tasks List (Fort Benning, GA: Headquarters, 75th Ranger Regiment, 6 May 1998), 1-4.

²⁶Mark Adkin, *Urgent Fury: The Battle of Grenada* (Lexington, MA: Lexington Books, 1989), 208, 222, 290.

²⁷Caleb Baker, Thomas Donnelly, and Margaret Roth, *Operation Just Cause: The Storming of Panama* (New York: Lexington Books, 1991), 332.

²⁸“Combat: Operation Just Cause Lessons Learned,” *Center for Army Lessons Learned*, [database on-line]; available from http://call.army.mil/call/ctc_bull/90-9/9091ch1b.htm; internet; accessed 17 November 1998.

²⁹John D. Lock, 494-495.

³⁰*Ibid.*, 496-566.

³¹William K. Fuller, LTC, telephone interview by author, Fort Leavenworth, KS, 28 February 1999.

³²Louis F. Tomasi, Ed.D., P.Rey Regualos, B.S., Gene Fober, Ed.D. and Matthew Christenson, B.S., “1995 Army Physical Fitness Test Update Survey” (Fort Benning, GA: U.S. Army Physical Fitness School, 1998), 2.

³³Department of the Army, AR 611-21, *Military Occupational Structure and Classification* (Washington, DC: Department of the Army, 1995), 2-41.

³⁴Marilyn A. Sharp, John F. Patton and James A. Vogel, “A Database of Physically Demanding Tasks Performed by U.S. Army Soldiers” (Natick, MA: U.S. Army Research Institute of Environmental Medicine, March 1998), vii.

³⁵USAREIM, *Assessing the Physical Demands and Direct Combat Probability of United States Army Organizations, Military Occupational Specialities and Duty Positions 1994*, pg. vii.

³⁶Sharp, vii.

³⁷W.S. Myles, J.I. Pope, and D.B. Van Loon, “An Evaluation of the Canadian Forces Battle Efficiency Test” (Ontario Canada: Defence and Civil Institute of Environmental Medicine, March 1985), 2-3.

³⁸John E. McLean II, MAJ, “The Amphibious Assault: How Fit Are Our Marines For the Mission?” (Master of Military Art and Science Thesis, Fort Leavenworth, KS: U.S. Army Command and General Staff College, May 1992), 68-75.

³⁹*Ibid.*, 9.

CHAPTER 3

RESEARCH METHODOLOGY

No man expects to live forever. But the man in perfect physical condition will live longer--especially in combat.

General Henry "Hap" Arnold

The method to determine if the 75th Ranger Regiment's physical fitness requirements relate to the physically demanding tasks that Rangers will perform in combat required a qualitative approach. Using the information available through literature review and personal interviews conclusions can be drawn that point to the true answer. The Analysis and Discussion chapters will identify further steps that should be taken to validate the conclusions with scientific study.

The study and research will be conducted in five steps in order to answer the primary question. The steps, in turn will answer the first four secondary questions. Subsequently, these secondary answers will be analyzed and compared to draw conclusions.

Question 1. What are the individual physical fitness requirements for service in the 75th Ranger Regiment?

The first logical step will be to determine the events that comprise the 75th Ranger Regiment's physical fitness requirements. The answer to this question will be found in the RTC 350-1, the Regimental Standards Booklet and the Regimental Commander's Policy Statement 20 (Footmarching). These events are the physically demanding tasks that are evaluated on a recurring basis against a specific standard.

The information collected to answer this question is determined through literature review and will, therefore, remain in that chapter. The question, however, is an important

building block toward solving the thesis problem and will be addressed in the Analysis Chapter.

Question 2. What parameters of fitness are required to perform the individual physical tasks outlined in the 75th Ranger Regimental fitness requirements?

Once the tasks were identified, each one will be evaluated to determine what physical parameter and major muscle groups were measured when performing the event. The physical parameters outlined in *Essentials of Strength Training and Conditioning* will serve as the standard for evaluation. Also, Kinesiology students and faculty at the University of Kansas will provide advice to assist in defining the tasks in terms of parameters and major muscle groups exercised. Specifically, the selected University of Kansas students and faculty member will confirm the procedures and methodology that this study is taking to determine the athletic profile of the Ranger and provide necessary suggestions to make the process more accurate. The final product of this step will be a list of physical parameters and muscle groups evaluated during the Ranger tests.

Question 3. What are the physically demanding tasks that Rangers may perform during combat operations?

This third step may prove to be the most challenging. As outlined in chapter 1, a questionnaire will be distributed to soldiers who served in the 75th Ranger Regiment, or one of its battalions, during combat since 1983. The questionnaire asks each respondent to describe the most physically demanding tasks he performed or observed during the operation.

The questionnaire will be distributed throughout the 75th Ranger Regiment and to students and faculty at the Command and General Staff College with Ranger Battalion

(or Regiment) combat experience. The respondents will be comprised of soldiers who served in positions at the battalion level or below during the respective conflict. There may be several respondents who served in more than one conflict, but those respondents will be asked to fill out separate questionnaires for each operation.

The questionnaire will be written in essay format and may allow the respondents to answer with too much variance, making it difficult to translate the tasks into common denominators.

In order to alleviate the variance in responses, the lists of tasks will be compiled and translated into the individual tasks outlined in the 75th Ranger Regimental Critical Task List and Soldiers' Training Pamphlet (STP) 21-1 *Soldiers' Manual of Common Tasks* (SMCT). Additionally, the conditions with which the tasks were performed will be noted (e.g., weight of the rucksack or distance walked) to ensure the tasks are translated accurately. If, however, there are any nebulous or confusing responses, follow-up interviews will be conducted for clarification.

Question 4. What components of fitness are required to perform the physical tasks identified in the selected combat operations?

Once the combat task list is finalized, each task will then be examined and translated into the physical parameters and muscle groups required to perform it. As with Step Two, the study will call upon the advice of Exercise Kinesiologists at the University of Kansas and the *Essentials of Strength Training and Conditioning* textbook to confirm that the procedures are sound. The final product of this step will be a list of physical parameters and muscle groups commonly required during the combat operations.

Thesis Question. Do the current 75th Ranger Regimental physical fitness requirements relate to the physically demanding tasks that a Ranger will perform in combat?

The final analysis will compare the list of physical parameters and major muscle groups measured during the Regimental Fitness requirements (outlined in Question 2) with the list of physical parameters and major muscle groups commonly required during combat (identified in Question 4). Quite simply, any parameter or major muscle group required to perform a task in combat that was not measured during established tests would demonstrate that the current fitness requirements were not adequate. Following the "Analysis," the final chapter, "Conclusion, Implications and Recommendations" will describe the shortfalls identified during analysis and recommend changes to the requirements to fill them.

CHAPTER 4

ANALYSIS

There are those who pride themselves on the number of push-ups, sit-ups and chin-ups they can perform, but no one has stressed how they can carry a wounded Marine the length of the parade ground without killing him. That is what we should know and be able to do.¹

General Alfred Gray, Kansas City Star

The data collected from research and interviews provided the answers to the four secondary questions outlined in the Methodology chapter. The subsequent analysis is organized to answer each question, in turn. The solutions to the questions provided the data for the final analysis and answered the primary question.

Question 1. What are the individual physical fitness requirements for service in the 75th Ranger Regiment?

The literature review of 75th Ranger Regiment training and standards documents provided a database of the individual fitness requirements that all Rangers must meet on a recurring basis. Those physical events are outlined in Table 4.

Table 4. Matrix of 75th Ranger Regiment Individual Fitness Requirements

Event	Time Limit	Standard
Push-ups	2 minutes	As per FM 21-20 (see appendix B)
Sit-ups	2 minutes	As per FM 21-20 (see appendix B)
Chin-ups	None	Minimum = 6
2-mile run	See standard	As per FM 21-20 (see appendix B)
5-mile run	40 minutes	Must remain in formation during the entire run
Footmarch	None	Must complete 10-, 20- and, 30-mile footmarches carrying loads between 30 and 50 lbs.

Question 2. What parameters of fitness are required to perform the physical tasks outlined in the 75th Ranger Regimental fitness requirements?

Once the events were identified the next step was to define what fitness parameters and major muscle groups are required to perform them. Each task was evaluated to determine which parameters of fitness, as defined in Dr. Thomas Baechle's book *Essentials of Strength Training and Conditioning*, were evaluated. Additionally, the judgments made were based on advice provided by Carol Zebas, PE.D., the course director for the Kinesiology Department at the University of Kansas.

Push-up

One repetition of the push-up exercise is performed when the Ranger, while in the front leaning rest position (see figure 1), lowers his body until his biceps and triceps are parallel to the ground and then raises it again, until his elbows are locked. The goal of this event is to complete as many correct repetitions within two minutes. The Ranger is only allowed to rest in the "up" position and cannot lift his arms or feet off the ground.²

According to Field Manual (FM) 21-20, *Physical Fitness*, this test measures the local muscular endurance of the chest, shoulder and triceps muscles. The Ranger is performing repeated contractions against a submaximal load (less than his body weight) for an extended period of time (two minutes).³

Sit-up

The Ranger begins the exercise on his back with his hands behind his head with fingers interlaced, and legs bent at a 90 degree angle (see figure 2). The Ranger raises his torso until his shoulder blades are perpendicular to the ground and then returns to the starting position for one complete repetition of the exercise. The Ranger must complete

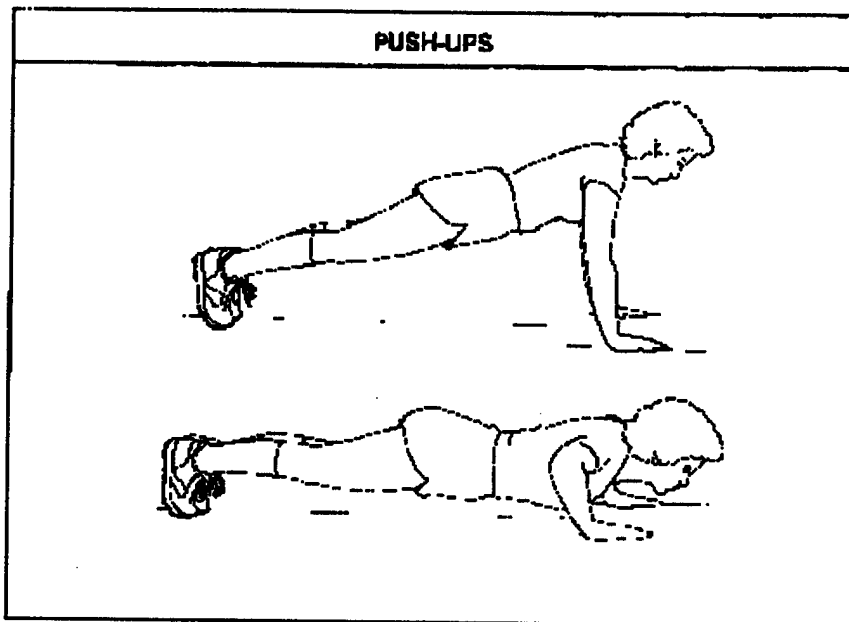

Figure 1. Push-up Exercise

as many correct repetitions as possible within two minutes. Also, he is allowed to rest in the "up" position during the two-minute time period.⁴

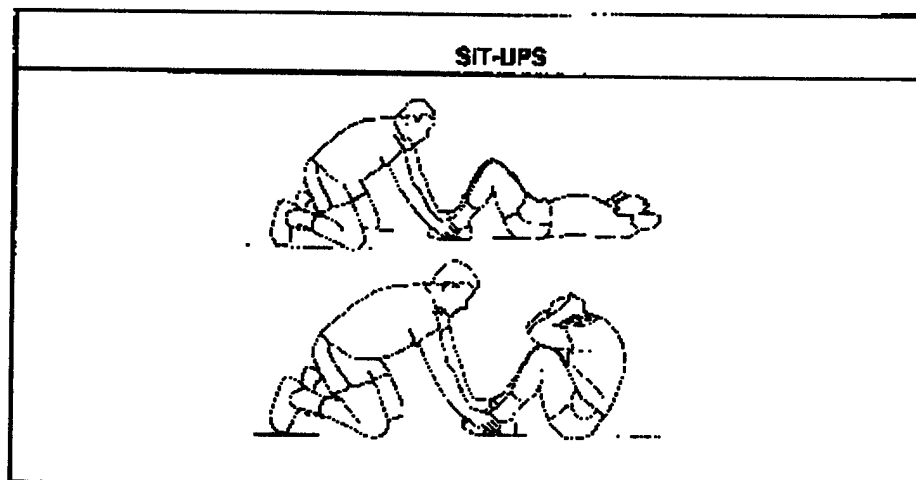

Figure 2. Sit-Up Exercise

Similar to the push-up exercise, this event measures the local muscular endurance of his abdominal and hip flexor muscles. The Ranger is performing repeated contractions against his body weight (submaximal) for an extended period of time (two-minutes).⁵

Chin-up

The Ranger begins the exercise by grasping a horizontal bar with his hands (palms facing inward) and allowing his body to hang freely (see figure 3). He pulls himself up until his chin is above the bar and then lowers his body until his arms are completely extended for one complete repetition. The Ranger performs as many chin-ups as he is physically able to do; there is no time limit.⁶

The chin-up exercise, like the push-up and sit-up, measures the local muscular endurance. In this case, it measures the endurance of the biceps, back and shoulder muscles when the Ranger performs repeated contractions against his body weight for an extended period of time (unlimited).

Two-Mile Run

The two-mile run requires the Ranger to run a two-mile course as quickly as possible. He is allowed to walk or rest at any time, but is highly discouraged from doing so.⁷

In this case, the exercise is measuring the Ranger's aerobic power by requiring him to perform an exercise that requires him to utilize oxygen. Studies have proven that the two-mile run test correlates well with the person's aerobic fitness as determined by his maximal oxygen intake or VO₂ max.⁸ To a lesser extent, it is also a measurement of local muscular endurance of the Ranger's leg muscles.

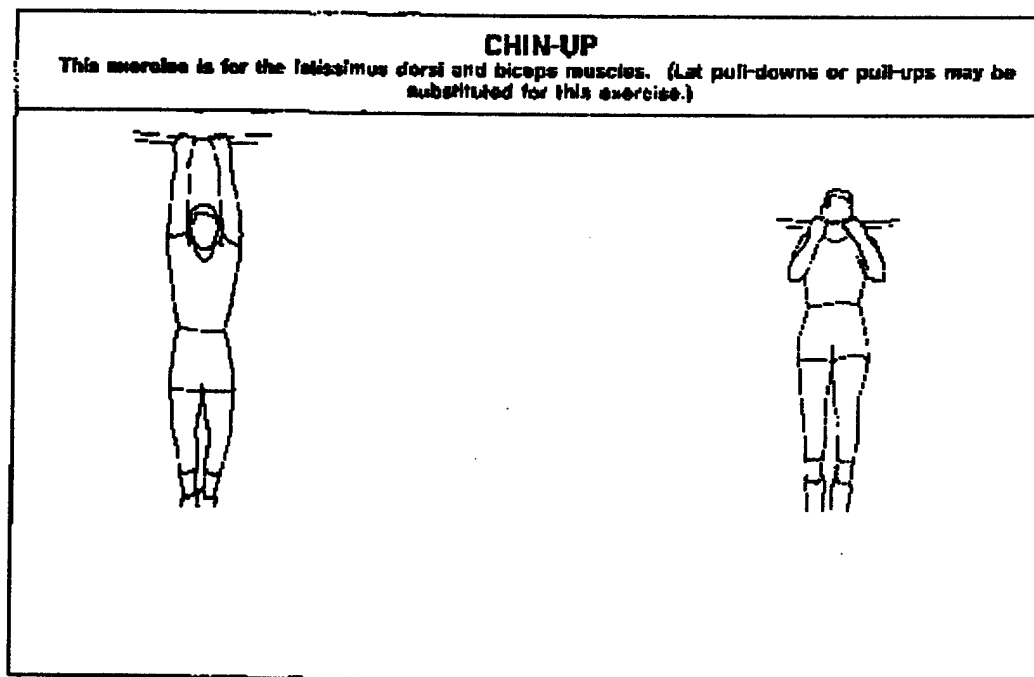

Figure 3. Chin-up Exercise

Five-Mile Run

The five-mile run event is a group event where the Ranger runs five miles in a unit formation. The run is conducted at an eight-minute per mile pace, allowing for a variance of fifteen seconds per mile. The Ranger has met the standard when he remains and completes the run with the formation.⁹

Like the two-mile run, this event measures the aerobic fitness since it requires the Ranger to use oxygen at a high aerobic rate, albeit not as effectively as a shorter distance. The event more closely measures the Ranger's leg muscular endurance since the length of time the Ranger runs brings him closer to muscle failure.

Foot March

Finally, the Rangers are required to perform weekly ten-mile foot marches and quarterly twenty and thirty-mile foot marches, alternating quarters. These marches are performed with Load Bearing Equipment (LBE) and ruck sack weighing between thirty to fifty pounds. As stated earlier, there is no time limit to perform the event, but the Ranger must be capable of transitioning to combat operations at its completion.¹⁰

The foot march measures the local muscular endurance of the leg and back muscles since the Ranger is carrying a load (submaximal) on his back over a long distance. To some extent, this event also measures aerobic power. Although there is no time requirement the Ranger still performs this movement at a pace that causes his heart and lungs to work at an aerobic rate and is thus a cardio-vascular exercise.

Summary

All of the events Rangers perform for their fitness requirements are exercises in local muscular endurance. In the case of the foot-march and running events, the exercise also measures aerobic power. Table 5 provides an overall matrix of events to physical parameters measured.

Table 5. Fitness Event to Physical Parameter Matrix

Event / Parameter	Muscular Strength	Local Muscular Endurance	Aerobic Power	Anaerobic Power	Agility	Speed
Push-up		X				
Sit-up		X				
Chin-up		X				
2 mile run		X	X			
5 mile run		X	X			
Foot march		X	X			

The local muscular endurance events are further subcategorized in terms of upper body, abdominal and lower body muscle groups in Table 6.

Table 6. General Muscle Groups Measured During the Local Muscular Endurance Fitness Events

Event / Muscle Group	Upper Body (arms, chest and back)	Abdominal	Lower Body (legs)
Push-up	X		
Sit-up		X	
Chin-up	X		
2 mile run			X
5 mile run			X
Foot march	X		X

Question 3. What are the physically demanding tasks that Rangers may perform during combat operations?

The questionnaire, described in the research methodology chapter relied on sample populations from two groups. The first group was comprised of students and faculty at the United States Army Command and General Staff College (CGSC) at Fort Leavenworth, Kansas, who had served in the Ranger Regiment (or one of its battalions) during the combat operations under consideration. The second group was comprised of soldiers currently serving in the 75th Ranger Regiment who had combat experience with the Rangers in the combat.

All of the students who were asked to respond to the survey provided input. Unfortunately, the questionnaires devoted to the 75th Ranger Regiment were distributed through electronic mail (e-mail) to anyone qualified and willing to respond. Thus, there is no way of determining the size of the population of *potential* respondents in order to determine a “nonresponse bias.”

In total, twenty-eight respondents answered the questionnaire, and in some cases many of those who provided input had participated in more than one conflict, making a total of forty-one responses. Table 7 depicts a breakdown of the surveyed population to their respective combat operations.

Table 7. Combat Experience of Questionnaire Respondents

Urgent Fury (Grenada)	Just Cause (Panama)	Desert Shield/ Storm (Saudi Arabia/Iraq)	Restore Hope (Somalia)	Uphold Democracy (Haiti)
3	18	3	4	13

These survey responses, combined with the literature review of the Ranger combat operations, provided the study with enough information to establish the database of tasks.

The limited responses for Desert Shield and Storm and Restore Hope are based on the fact that both operations involved a small element from the Regiment; one company team was involved in Operation Desert Shield and Storm and one battalion (-) participated in Operation Restore Hope.

As discussed, the answers varied in the “language” the respondents used to describe the physically demanding tasks they performed or observed. In order to develop a database the responses were translated into the tasks outlined in the 75th Ranger Regiment Critical Task List (CTL). In some cases, the tasks described in the questionnaire were not identified in the CTL, so the STP 21-1 *Soldier’s Manual of Critical Tasks* (SMCT) was used. Any task that was identified greater than five times was included on the list for evaluation. In one case, movement under direct fire was

broken down into three different conditions based on the type of terrain negotiated due to the nature of the obstacles the Ranger faces (e.g., walls and windows in an urban environment requires more climbing than on an open airfield)

The tasks that received the greatest amount of responses are outlined in Table 8, with the number of responses given.

Table 8. Physically Demanding Combat Tasks List

Task	Conditions	Number of Responses
Move under direct fire		
	On an Airfield (open terrain)	10
	In wooded terrain	4
Perform Movement Techniques during MOUT		6
Transport an unconscious casualty	Average weight of 200 lbs.	11
Perform parachute jump and parachute landing fall (PLF)	With combat equipment	6
Move tactically during a long movement/time (patrolling)	Urban or wooded terrain; patrolling for over an hour; with combat load	29

Again, these are tasks that the respondent perceived were physically demanding not just ones that they performed. For example, twenty-one of the respondents performed a parachute jump into their respective operation, yet only six of them perceived that it was physically demanding. However, based on the literature review described earlier, these responses are consistent with those physical tasks performed by Rangers in those combat operations.

The fourth and final step was to define these tasks in terms of physical parameters and major muscle groups utilized by the Ranger performing them.

Question 4. What components of fitness are required to perform physical tasks identified in the selected combat operations?

Each of the tasks identified in the questionnaire were cross-matched with individual skills manuals published by the United States Army. In all but two cases, each task matched one outlined in the SMCT or the STP for Infantrymen.

The tasks were then broken down into physical components required to perform the task. Then, as with the fitness events, each component was evaluated to determine what parameter of fitness was required to perform that component.

Move Under Direct Fire (071-326-0502)

This task, outlined in the STP-21-1-SMCT, describes the actions soldiers take when moving within the small arms range of an enemy position. The manual describes the movement techniques necessary to survive and get to the position to neutralize or destroy it.

The training and evaluation outline describes three maneuvers that require physical exertion to perform them. These tasks are the three-to-five second rush, low crawl and high crawl. Any of these tasks may be performed during the exercise, depending upon the enemy and friendly situation.

Looking at the physical parameters required to perform these movements, it is clear that the three-to-five second rush requires agility, speed and anaerobic power. During this movement, the Ranger begins in the prone position, behind cover. Upon the signal from his buddy, he rolls to the side, jumps to his feet, runs to another covered and concealed position and assumes the prone again.¹¹ The Ranger must move quickly and

be in position within three to five seconds in order to prevent the enemy from having an opportunity to acquire and fire at him. Clearly, the Ranger must be agile and fast as he runs to the positions and changes positions during the movement. Additionally, the action of rolling to his side and jumping to his feet requires an explosive movement provided by anaerobic power.¹²

The low crawl and high crawl movements require local muscular endurance because in both cases the Ranger crawls to the next position by pushing and pulling his arms and legs along the ground.¹³ Potentially, the Ranger may have to perform this movement for 100 meters, requiring him to repeat the motion against his body weight and equipment (submaximal). This movement also requires agility as he may change direction during the movement to avoid enemy fires.¹⁴

Perform Movement Techniques During MOUT (071-326-0541)

Tactical movement in an urban environment is described in STP 7-11BCHM-SM-TG, the training manual devoted to all infantrymen for Skill Levels 1--4. The techniques described in this manual are very similar to those described above with some changes.

When fighting in urban terrain the Ranger is faced with different types of obstacles that must be negotiated to eliminate or capture the enemy position.¹⁵ In these cases, the Ranger requires other physical parameters than those required for low crawl, high crawl and three-to-five second rush.

Specifically, the Ranger can be expected to climb into openings in a building, up ropes or over walls. When he performs these climbing tasks he is usually carrying his combat load with weapon and Load Bearing Equipment (LBE). Therefore he will

require muscular strength to lift his body into the opening or up the rope, since it is a one time occurrence and not over an extended period of time (muscular endurance).

Additionally, he may have to jump to reach the top of the obstacle (e.g., wall ledge) and will thus require anaerobic power during this explosive movement. Finally, negotiating these types of obstacles requires a certain amount of agility as he maneuvers his body over and into a safe position.

Transport a Casualty Using a One Man Carry (081-831-1040)

This task is also found in STP 21-1-SMCT describing how a soldier moves a casualty to a point of safety where he can receive further medical attention. In the case of the operations examined, the average weight of the casualties was 200 pounds. The STP further states that the one carrying the injured soldier has a choice of the types of carries he may perform.

The most physically demanding carries described in the manual are the fireman's carry and the arms carry. In each case, the casualty is unconscious and the Ranger must lift him from the ground and carry him over his shoulders (fireman carry) or with his arms (arms carry).¹⁶

The physical demands of this task vary depending on the situation. Generally, however, the Ranger requires muscular strength in his back, arms and legs to initially lift the casualty. He then may require aerobic power as he moves the casualty to a position of safety, if he is under fire. Similarly, this task could require agility and speed to avoid becoming a casualty himself.

Perform a Parachute Jump and Landing Fall

This task is not outlined in any Soldier Training Publication but is described in FM 57-220, *Basic Parachute Techniques and Training*. The questionnaire revealed that Rangers performed parachute operations during Urgent Fury and Just Cause. In each case, the Rangers jumped with the T-10 parachute and reserve with combat load. During both operations the Rangers ruck sacks weighed between 80 and 100 pounds. Adding those weights to the parachute and harness (38 pounds), the total weight that the Ranger carried was 118 to 138 pounds.

In terms of physical parameters, the Ranger initially requires the muscular strength of his legs and back when he stands up to lift this load during the final preparations for the parachute jump. Once erect, the requirement transitions to one of back, leg and shoulder local muscular endurance, depending on how long he must stand and wait to exit the aircraft. In Operation Urgent Fury, Rangers stood for extended periods of time waiting for the aircraft to make another "pass" on the drop zone.

Move Tactically Over Long Distances or Time

This individual task is not described in any soldier training publication or field manual, yet received the greatest number of responses in the questionnaires. In every operation, once the initial hostilities were complete, Rangers conducted security patrols where they traveled long distances on foot. The conditions varied, such as urban environment during Haiti or field environment during Just Cause, but generally each Ranger walked for over an hour and carried a combat load of some type.

Physically, this task correlates well with the foot march requirements outlined in the 75th Ranger Regiment fitness requirements; that is, he requires the endurance of his leg and back muscles.

Summary

The questionnaire revealed that the physical requirements that Rangers faced during combat were varied. An overview of those parameters is outlined in Table 9.

Table 9. Combat Task to Physical Parameter Matrix

Task/ Parameter	Muscular Strength	Local Muscular Endurance	Aerobic Power	Anaerobic Power	Agility	Speed
Move under direct fire		X		X	X	X
Perform mvmt tech in MOU	X	X		X	X	X
Perform parachute jump	X	X				
Transport a casualty	X	X	X		X	X
Move tactically over long distances/ time		X	X			

Like the local muscular endurance tasks measured during the Regimental fitness events, the combat tasks that required local muscular endurance were further subdivided into the major muscle groups. Table 10 outlines those tasks and muscle groups.

Final Analysis

In the final analysis, it appears that a disconnect lies between the physical parameters required for the Regimental fitness events and those required in combat. The

qualitative analysis clearly shows that combat requires Rangers to display agility, speed, anaerobic power, aerobic power, muscular endurance and muscular strength whereas the fitness tests only measure local muscular endurance and aerobic power. Table 11 demonstrates the level of correlation between the fitness events and the combat tasks in terms of physical parameters.

Table 10. General Muscle Groups Measured During the Local Muscular Endurance Combat Tasks

Task / Muscle Group	Upper Body (arms, chest and back)	Abdominal	Lower Body (legs)
Move under direct fire	X	X	X
Perform mvmt tech in MOU	X	X	X
Perform parachute jump	X		X
Transport a casualty	X		X
Move tactically over long distance/time	X		X

Table 11. Regimental Fitness Events Versus Combat Tasks Physical Parameter Comparison

Event -vs- Task / Parameter	Muscular Strength	Local Muscular Endurance	Aerobic Power	Anaerobic Power	Agility	Speed
Fitness Events		X	X			
Combat Tasks	X	X	X	X	X	X

Also, in terms of the local muscular endurance both the Regimental fitness standards and the individual combat tasks call upon the endurance of all major muscle groups identified.

Admittedly, this study is limited due to its qualitative nature and the results can be best termed as a "best guess," and are not infallible. However, based on the responses of the questionnaire participants and the detailed research the results provide an adequate level of reliability for the conclusions drawn from the analysis.

The final chapter will identify further studies that should be instituted to scientifically validate this conclusion as well as recommend test events to fill the "void" of the current Regimental fitness test.

¹Associated Press Dispatch, "New Commandant Talks to His Marines," *Kansas City Star*, 5 October 1987, p. 3, columns 1-3.

²Department of the Army, FM 21-20, *Physical Fitness Training* (Washington DC: Department of the Army, 30 September 1992), 14-11.

³Ibid.

⁴Ibid., 14-14.

⁵Ibid.

⁶Headquarters, 75th Ranger Regiment, RTC 350-1, *Training* (Fort Benning, GA: 75th Ranger Regiment, 1998), O-1.

⁷FM 21-20, 14-17.

⁸M. Murphy, R. Mello, and J. Vogel, *Relationship Between a Two-Mile Run for Time and Maximal Oxygen Uptake* (Natick, MA: US Army Research Institute of Environmental Medicine, 1987), 9.

⁹RTC 350-1, appendix O-1.

¹⁰Ibid.

¹¹Department of the Army, STP-21-1-SMCT, *Soldier's Manual of Common Tasks* (Washington, DC: Department of the Army, 1994), 221-231.

¹²Thomas R. Baechle, *Essentials in Strength Training and Conditioning*, ed., Thomas R. Baechle, Ed.D., CSDS (Omaha, NE: National Strength and Conditioning Association, 1994), 248.

¹³STP-21-1-SMCT, 221-231.

¹⁴Baechle, 248.

¹⁵Department of the Army, STP-7-11BCMH-SM-TG, *Soldier Training Plan* (Washington, DC: Department of the Army, 1989), 3-397.

¹⁶STP 21-1-SMCT, 527-534.

CHAPTER 5

CONCLUSIONS, IMPLICATIONS AND RECOMMENDATIONS

Conclusions

This study attempted to answer the research question, "To what extent do the physical fitness requirements of the 75th Ranger Regiment correlate to the physically demanding tasks that Rangers will perform in combat?" In order to determine the answer, however, the following subordinate questions had to be solved through literature review and analysis:

1. What are the fitness requirements for service in the 75th Ranger Regiment?
2. What parameters of fitness are required to perform the physical tasks outlined by the 75th Ranger Regimental fitness requirements?
3. What are the physically demanding tasks that Rangers may perform during combat operations?
4. What parameters of fitness are required to perform the combat tasks identified in the selected combat operations?

Afterward, the two lists developed in questions 2 and 4 were compiled and compared to determine their correlation and answer the primary research question. The answers to these questions and subsequent recommendations are listed herein.

Ranger Regimental Fitness Requirements and Parameters Measured (Question 2)

The literature review and research demonstrated that the current Ranger Regimental fitness requirements only measure a limited number of physical parameters. First, requirements such as the push-up, sit-up, chin-up and foot march measure the local muscular endurance of specific muscle groups. These exercises measure the ability of a

muscle or muscle group to perform repeated contractions against a submaximal load for a specific period of time (e.g., push-ups in two minutes). Second, the two-mile and five-mile runs and foot march events measure the Ranger's aerobic power because they are measuring the amount of work the Ranger can perform based on the amount of oxygen he utilizes. In layman's terms, the two- and five-mile run and foot march requirements force the Ranger to move at a pace that causes his heart and lungs to work harder than normal.

Combat Fitness Requirements and Parameters Measured (Question 4)

The questionnaire and subsequent analysis attempted to identify the physically demanding tasks that Rangers have performed in combat since 1983. These physical tasks were subsequently translated into the physical parameters required to perform them.

Among the myriad tasks identified: moving under direct fire, performing movement techniques in an urban environment, transporting an unconscious casualty, and performing a parachute jump were perceived by the respondents to be the most physically demanding tasks they performed or observed. Further analysis demonstrated that these tasks not only required muscular endurance and aerobic power but also demanded speed, agility, muscular strength, and anaerobic power.

It should be noted though, that none of the Rangers interviewed perceived that they were not physically prepared for combat. This perception, however, was a reflection of their individual or small unit physical training program, and not based on meeting the Ranger Regiment's physical standards alone.

Correlation

Based on the results, the study concluded that the Ranger Regimental fitness tests do not accurately measure a Ranger's ability to perform his job in a combat situation.

Specifically, the tasks requiring muscular endurance and aerobic power seem to correlate well with the fitness requirements, but these requirements do not measure up to those required in combat. The current test does not adequately provide instruments to measure the Ranger's speed, agility, muscular strength and anaerobic power all of which were identified as important to success during the combat operations examined in this study.

Implications

This conclusion implies that the 75th Ranger Regiment could potentially benefit from designing a fitness test that is more closely related to the physical requirements of combat. Clearly, poor physical fitness testing has not prevented the Ranger Regiment from accomplishing its missions in combat but a better system to measure fitness could improve the Ranger's confidence in his combat readiness. In other words, if a Ranger knew that he could perform fitness tasks that related directly to his performance in combat tasks than he may be more confident when he faces any combat situation.

Field Manual 21-20, *Physical Fitness Training* recommends, "mission essential tasks, not the APFT, should drive physical training."¹ Likewise, those mission essential tasks and their associated collective and individual tasks should dictate the criteria for fitness testing to measure combat readiness. As discussed earlier, the 75th Ranger Regiment should appreciate the need to focus their training toward mission essential tasks more than any other unit as they may be in a combat operation within the next nine hours.

Taking a step further, the responses from the questionnaires and subsequent analysis, this study could apply to all United States Army Infantry organizations. Except for "performing parachute operations" all infantry soldiers can be expected to perform the combat tasks identified in the study. Tasks, such as "Move under direct fire" and

“Perform movement techniques in an urban environment (MOUT),” are outlined in Soldier’s Manual of Common Tasks (SMCT) and Soldier’s Training Publications (STP) and are not unique to the 75th Ranger Regiment.

Furthermore, infantry soldiers are only required to meet the standards of the Army Physical Fitness Test (APFT). Quite simply, outside of the 75th Ranger Regiment, no other U.S. Army infantry organization adds additional fitness requirements for service. Thus, the only “official” measure of the infantryman’s fitness is through the APFT.

Logically, then, if the APFT only measures aerobic power and muscular endurance but infantrymen, like Rangers, also require speed, agility, and anaerobic power then the APFT is not a suitable test alone. A test, based on the criteria to perform infantry duties, is required to effectively evaluate an infantryman’s physical ability to fight in combat.

Recommendations

Based on the results of the analysis and subsequent conclusions, the Ranger Regiment should develop a test that measures all of the physical parameters required in combat. Such a test should be administered in lieu or in conjunction with the APFT in order to provide a standard for Rangers to meet (and exceed) that reflects the physical rigors of combat. Any test developed to measure combat readiness must, also, meet the reliability, objectivity and validity criteria necessary for all testing, described in Chapter 2.

Suggested Test Events

Dr. Thomas Baechle in his book, *Essentials of Strength Training and Conditioning* provides advice and practical suggestions for developing tests to measure

the physical parameters, which are not included in the current Ranger Regimental fitness program. These tests are designed to measure the specific physical parameter identified and are conducted in a gymnasium, or other controlled environment to ensure minimal variance in performance and scoring.

Muscular strength tests measure the soldier's ability to perform one repetition of the exercise at maximum weight. Obviously, the soldier is allowed at least two to three minutes of rest between attempts. A practical test that is often used is the bench press to measure chest and arm strength and the squat bend to measure leg strength.²

It is commonly accepted, however, that performance in muscular endurance events correlates well to performance in muscular strength events. Thus, if a soldier is tested for the muscular endurance of a specific muscle group, then it satisfies the requirement for measuring muscular strength in the same muscle group.³

Anaerobic power tests measure the soldier's ability to perform brief maximal muscular activity; characterized by explosive movements. The most common tests to measure the anaerobic power of the legs is the vertical jump, 30- to 50-yard sprints or the 300-yard shuttle run, where the soldier runs six fifty-yard laps from one point to another, for a total of 300 yards.⁴

Agility tests measure the soldier's ability to start and change direction of body movements, for usually less than ten seconds in duration. An example of an agility test is the T-Test, where the soldier runs a short course that requires him to sprint and change direction between cones set up in a "T" formation. This test must be administered in an area that will prevent the soldier from slipping.⁵ Another test is the "Run-Dodge-and

Jump” that the United States Army used to include in the fitness test. As the name implies, this test required the soldier to negotiate several obstacles over a short distance.⁶

Finally, speed tests measure the soldier’s ability to move over a short distance quickly. Commonly these tests are running events where the subject runs distances between 40 and 100 meters.⁷

Recommendations for Further Study

The following recommendations are offered as a result of this study.

Repeat the Test with Quantitative Analysis

This study should be repeated using more scientific and quantitative means. When determining the physically demanding tasks Rangers perform a survey should be administered to not only combat veterans, but also to Rangers currently serving in the Ranger Regiment. Basing results on combat since 1983 can be skewed since all of the operations Rangers have taken part in have only lasted a short duration. Today, Rangers not only train for quick missions, but they also train for sustained combat.

Once those tasks are identified they can be translated into the physical parameters, similar to this study, then compared to the current fitness requirements. Afterwards, the conclusions drawn will point to the validity of the current requirements.

Develop an Alternative Test and Compare Results

Another approach to solving the problem could be through determining the correlation of results from the Ranger Regimental fitness test to results on tests that more closely measure combat task physical parameters. This study would be similar to the Master of Military Art and Science thesis published by Major John McLean II, described in the “Literature Review.”

In this case, once the physically demanding combat tasks are determined, a test (or battery of tests) could be developed that correlates to those tasks and administered to a sample population of Rangers. Next, the results of this test would be compared to the results of the Ranger Regimental fitness tests, administered to the same sample group, through statistical analysis to determine if an adequate correlation exists. For example, does performance on the push-up test (Ranger Regimental event) correlate to performance on the "combat" test? If so, then the Ranger Regimental fitness requirements could be a satisfactory test to determine combat physical readiness. If not, then the Ranger Regimental test should be altered to better reflect the combat requirements.

Standardize the New Criterion Based Test

If the results of the follow-on tests prove that the current fitness requirements do not correlate with combat requirements then a new criterion based test should be developed for the Ranger Regiment. This test would measure those physical parameters identified in the previous study. Of course, further testing would be required in order to establish the standards for performance. This testing should involve a large sample of Rangers serving in the Ranger Regiment to ensure validity, reliability and objectivity-the three standard criteria for any fitness test.⁸

Ranger Fitness Program

Another study should be initiated to determine the optimal Ranger physical fitness *program*. Once the combat task physical parameters are determined, this study could examine what type of physical fitness program Rangers should follow to meet the standards (and exceed) outlined by the test. This program should outline the types and

frequency of exercises Rangers should perform to maximize performance and minimize injury.

Combat Tasks and Fitness Test Study

The suggested test events, described earlier, measure specific physical parameters in a controlled environment (e.g., gymnasium). However, can a test be designed to measure those physical parameters *and* simulate the conditions of the combat task? For example, a test could be designed to measure the muscular strength and endurance, aerobic power, agility, and speed necessary to transport a casualty by measuring how quickly a Ranger can carry a 200-pound mannequin over a specific distance. In this case, the task is directly related to the combat task he will likely perform in combat. A major drawback, however, is the possible sacrifice of objectivity, reliability and validity. For example, can this be a reliable test if the conditions he performs it in can vary at any time (e.g., weather, ground)?

A study should be conducted to determine if a “combat task” test can be developed to meet the scientific requirements for fitness testing. Naturally, a dedicated sample population will be necessary to validate any of the test events against the three criteria (described above) and to establish standards of performance.

Studies on-going in the 75th Ranger Regiment

During the course of this research, the 75th Ranger Regimental Commander asked the United States Army Physical Fitness Unit (USAPFU) to assist the Ranger Regiment with developing a more battle focused physical training program. Part of that program included developing tests that evaluate the Ranger’s ability to perform his duty. It should

be noted, however, that the results of the USAPFU program and related study were not included in this thesis in order to prevent any possible contamination of the results.

In February 1999, 2nd Ranger Battalion with the assistance of Captain Dan Norvell, MPT (Physical Therapist), developed the "Total Ranger Physical Enhancement Program."⁹ Like this study, a key component for his research was determining the physical requirements of combat. Afterwards, he designed a test to evaluate the Ranger's physical performance and a program to improve that performance.

To determine the physical requirements of combat, Captain Norvell and Captain Lee Barton, the 2nd Battalion Surgeon, gathered a panel of officers and noncommissioned officers called the "Physical Training (PT) Working Group." Based on their collective experience, this group developed a list of physically demanding tasks that the Rangers in 2nd Battalion typically perform during training. Afterward, they translated those tasks into physical parameters and developed test events to measure the parameters.¹⁰

The results of the 2nd Battalion study revealed that the current fitness tests lack the same parameters identified in this study. The 2nd Battalion study also, identified the same physically demanding tasks that Rangers perform, albeit using different terminology. Thus, to some extent, then the 2nd Battalion study validates the research performed here in terms of physical tasks that "today's Ranger" performs.

Closing

In a world of competing demands and diminished resources, focus should be the "watchword" in all that the 75th Ranger Regiment does. Every aspect of training and performance should be geared toward preparing the Ranger for the combat he will face. Likewise, the 75th Ranger Regiment cannot afford to miss the opportunity to adequately

measure the Ranger's physical capabilities for combat operations. A better fitness standard and subsequent fitness program will give him the confidence he needs "to fight on to the Ranger objective and complete the mission, though he be the lone survivor."¹¹

¹Department of the Army, FM 21-20, *Physical Fitness Training* (Washington, DC: Department of the Army, 30 September 1992), 14-1.

²Douglas M. Semenick, *Essentials in Strength Training and Conditioning*, ed. Thomas R. Baechle, Ed.D., CSCS (Omaha, NE: National Strength and Conditioning Association, 1994), 259.

³Louis F. Tomasi, Ed.D., telephone interview by author, Fort Benning, GA: 11 March 1999.

⁴Semenick, 260.

⁵*Ibid.*, 268.

⁶Department of the Army, FM 21-20, *Physical Fitness Training* (Washington, DC: Department of the Army, 1973), 160.

⁷Semenick, 268.

⁸*Ibid.*, 250.

⁹Daniel Norvell, M.P.T., "Total Ranger Physical Enhancement Program" (slide packet), Fort Lewis, WA: Headquarters, 2nd Battalion, 75th Ranger Regiment, 18 February 1999.

¹⁰Daniel Norvell, M.P.T., telephone interview by author, Fort Lewis, WA: 18 February 1999.

¹¹Neil Gentry, CSM, "The Ranger Creed." *Ranger Standards Booklet*. (Fort Benning, GA: 75th Ranger Regiment, 24 February 1999), iv.

APPENDIX A

75TH RANGER REGIMENT TASK ORGANIZATION

REGIMENT

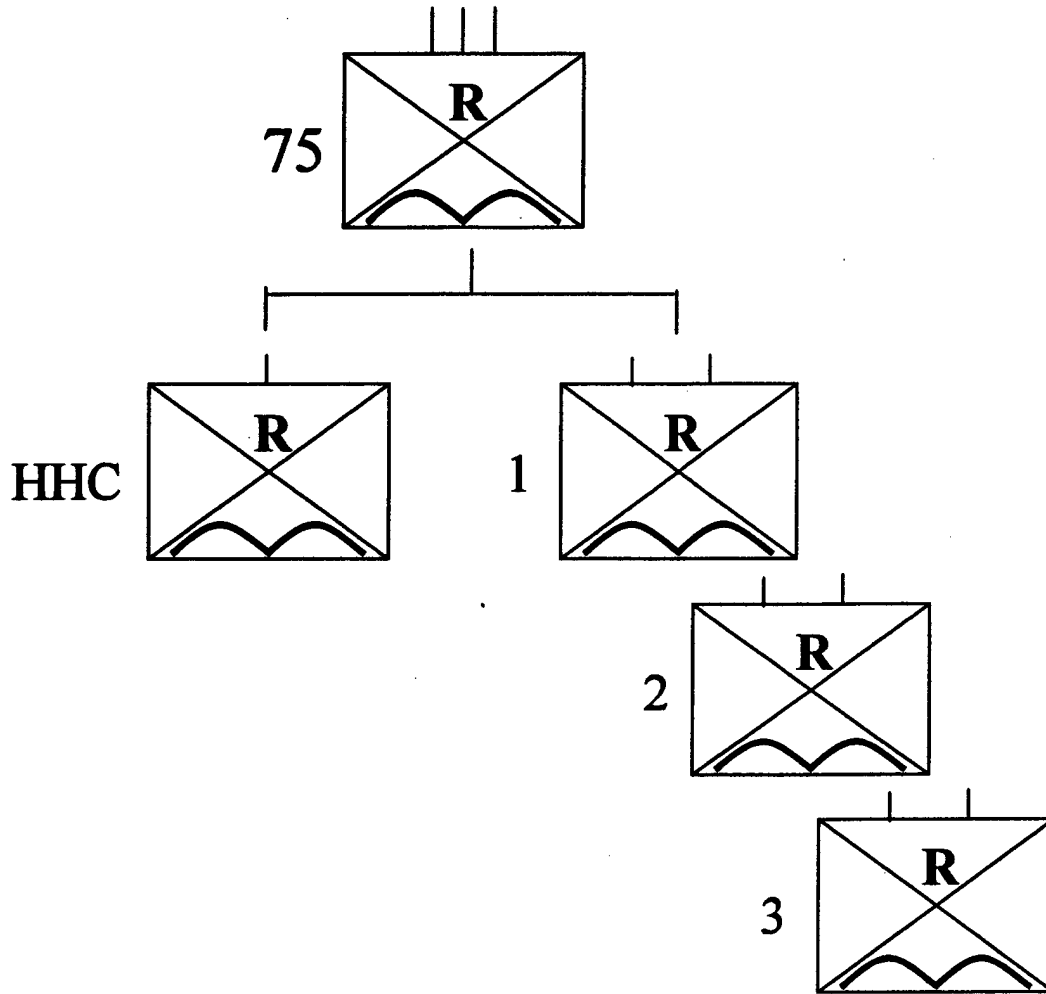

RANGER BATTALION ORGANIZATION

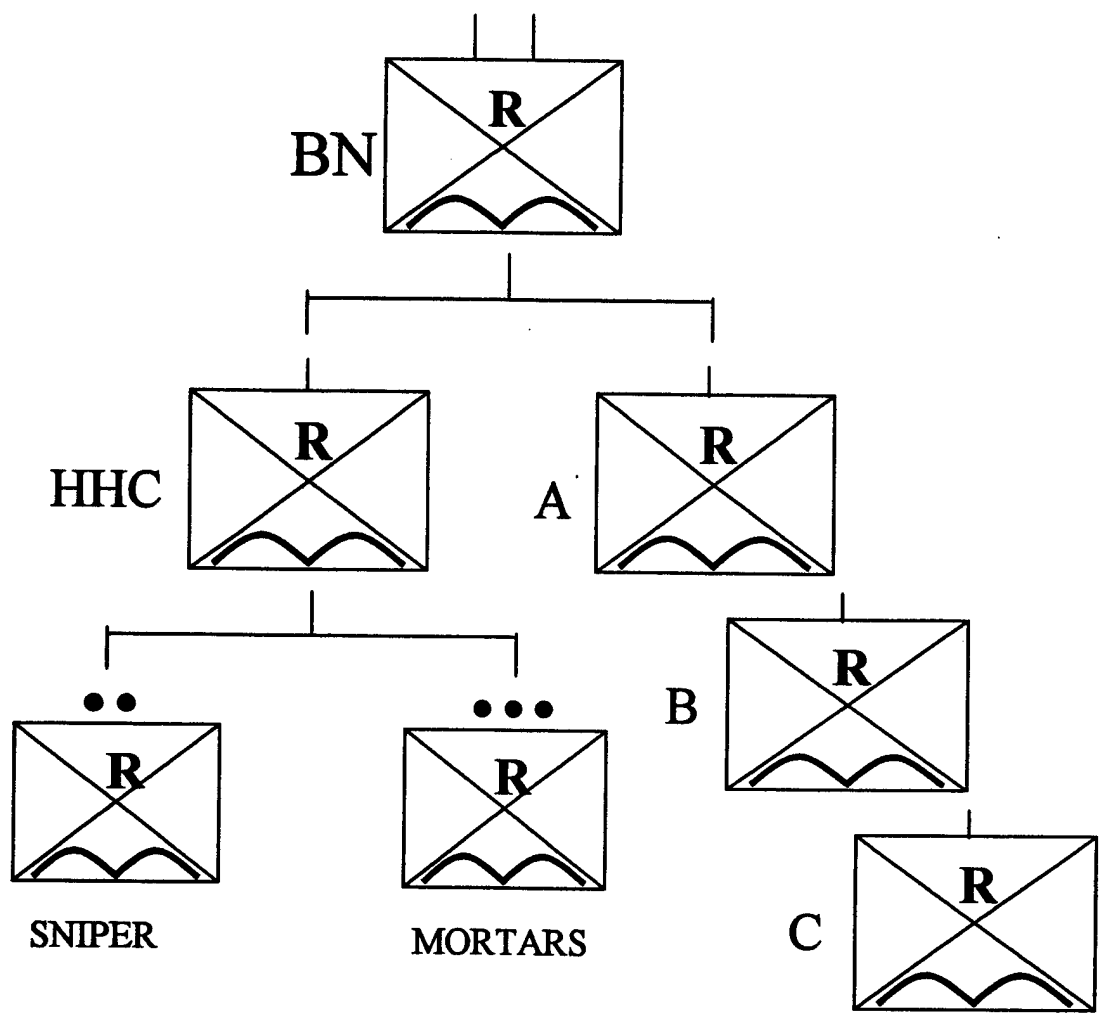

RANGER RIFLE COMPANY ORGANIZATION

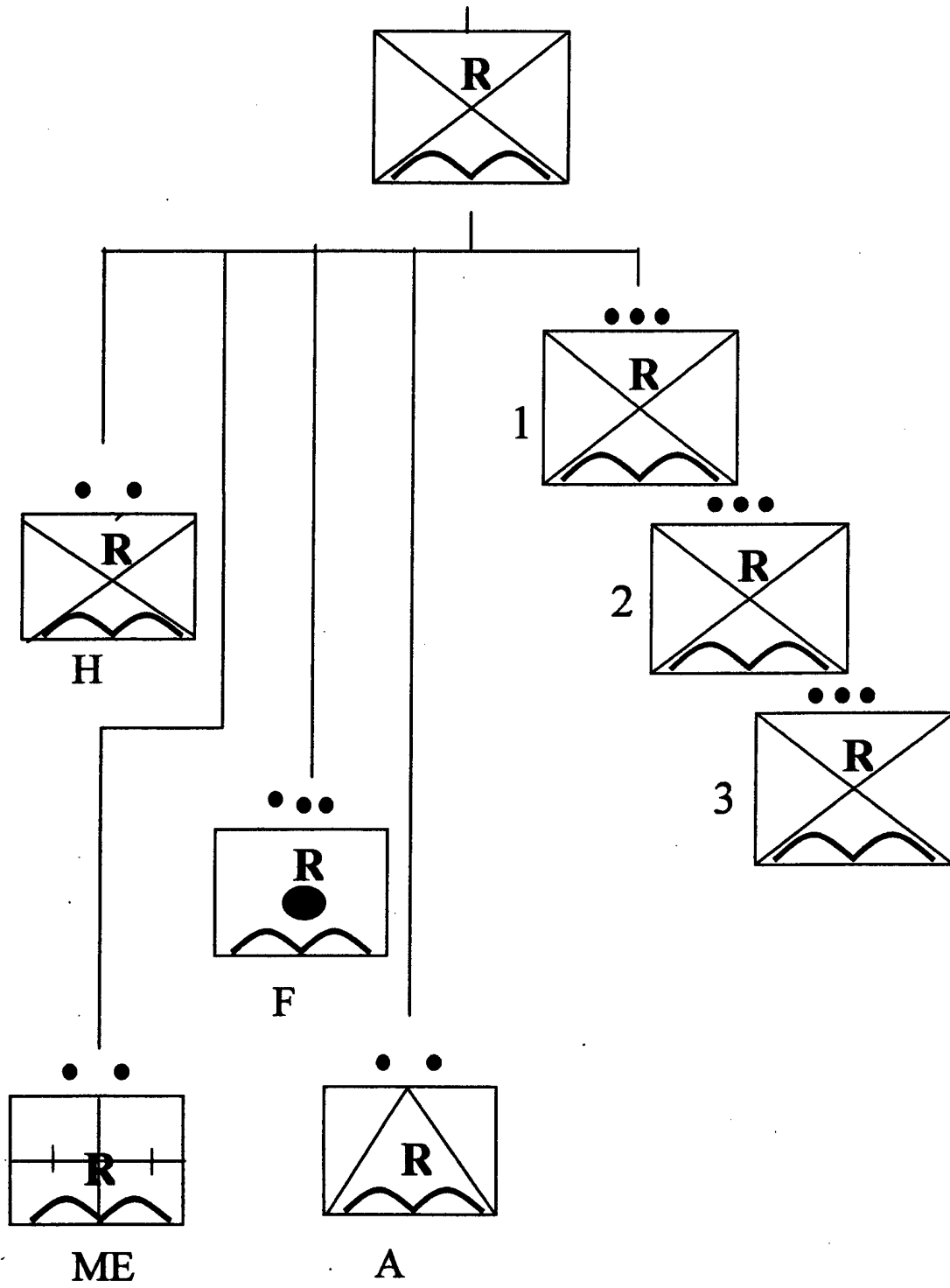

APPENDIX B QUESTIONNAIRE

Purpose. This questionnaire will identify the physically demanding tasks that Rangers have performed in combat operations since 1983. It is part of an overall study determining how the current Ranger Fitness Standards (i.e. APFT, chin-ups, road march, five-mile run) relate to the critical individual tasks that Rangers are required to perform in combat.

Participants. Soldiers who have served with the Ranger Regiment (or one of its battalions) during recent combat operations, to include the following:

- a. Operation Urgent Fury (Grenada)
- b. Operation Just Cause (Panama)
- c. Operations Desert Storm (Iraq)
- d. Operation Restore Hope (Somalia)
- e. Operation Uphold Democracy (Haiti)

1. Name/Rank (current rank). If retired, last rank held and date of retirement.
2. Dates of service and duty positions held with 75th Ranger Regiment.
3. Combat Operations participated in with 75th Ranger Regiment.

Note: If the interviewee participated in more than one operation, then he will answer these questions for each operation, separately.

4. What battalion, company, and platoon did you serve with during Operation _____?
5. What was your duty position in the squad/platoon/company during Operation _____?
6. What missions did your company or platoon participate in during Operation _____?
7. What respect to each of the following components of fitness what were the most physically demanding tasks you perform? Or you observed being performed by others in your unit?

Each task will be defined by the interviewee

- a. Muscular strength (upper or lower body)
- b. Muscular endurance
- c. Aerobic power
- d. Balance

8. What was the longest foot movement you performed during the operation?
9. Did you wear a rucksack during these movements? How much did it weigh?
10. Did you feel you were physically prepared for the operation? If not, which component(s) of fitness did you feel you (or your men in the unit) should have concentrated more on during training?

GLOSSARY

Aerobic Power. The amount of work a person can perform, normally determined by the rate at which oxygen is utilized during the exercise.

Agility. The ability to change the direction of the body or body parts rapidly under control.

Anaerobic Power. The amount of work performed using primarily anaerobic energy systems. Anaerobic power is strongly related to explosive movements.

Local Muscular Endurance. The ability of a muscle or muscle group to perform repeated contractions against a light (submaximal) load for an extended period of time.

Muscular Strength. The force that a muscle or muscle group can exert against a resistance in one maximal effort.

Speed. The rapidity of movement.

Submaximal Exercise. An exercise at an intensity below that observed for maximal exercise (effort).

Test Objectivity. The degree to which multiple scorers agree on the magnitude of scores.

Test Reliability. The degree of consistency which a test measures what it measures; it is essentially the repeatability of the test.

Test Validity. The degree to which a test measure what it is supposed to measure.

VO2 Max. Maximal oxygen consumption or aerobic power.

BIBLIOGRAPHY

Books

- Adkin, Mark. *Urgent Fury: The Battle for Grenada*. Lexington, MA: Lexington Books, 1989.
- Baechle, Thomas R., ed. *Essentials of Strength Training and Conditioning*. Champaign, IL: National Strength and Conditioning Association, 1994.
- Baker, Caleb, Thomas Donnelly, and Margaret Roth. *Operation Just Cause: The Storming of Panama*. New York: Lexington Books, 1991.
- Clausewitz, Carl von. *On War*. Edited and translated by Michael Howard and Peter Paret. New Jersey: Princeton University Press, 1984.
- Fox, Edward L., and Donald K. Mathews. *The Physiological Basis of Physical Education and Athletics*. Philadelphia: CBS College Publishing, 1981.
- Lock, John D. *To Fight With Intrepidity: The Complete History of The U.S. Army Rangers 1622 to Present*. New York: Pocket Books, 1998.
- Marshall, S. L. A. *The Soldier's Load and the Mobility of a Nation*. Quantico, VA: The Marine Corps Association, 1950.
- Miller, D. K. *Measurement for the Physical Educator: Why and How*. Dubuque, IA: WCB McGraw-Hill, 1998.
- Noble, Bruce J. *Physiology of Exercise and Sport*. St. Louis: Times Mirror/Mosby College Publishing, 1986.
- Turabian, Kate L. *A Manual for Writers*. 6th ed. Chicago: University of Chicago Press, 1993.

U.S. Government Publications

- Department of the Army. AR 350-41, *Training in Units*. Washington DC: Department of the Army, 1993.
- _____. AR 611-20, *Military Occupational Structure and Classification*. Washington, DC: Department of the Army, 1995.
- _____. ARTEP 7-8 MTP, *Mission Training Plan for the Infantry Rifle Platoon and Squad*. Washington DC: Department of the Army, 1988.

- _____. ARTEP 7-8 Drill, *Battle Drills for the Infantry Rifle Platoon and Squad*. Washington DC: Department of the Army, 1993.
- _____. FM 7-8, *Infantry Rifle Platoon and Squad*. Washington DC: Department of the Army, 1992.
- _____. FM 21-18, *Foot Marches*. Washington DC: Department of the Army, 1990.
- _____. FM 21-20, *Physical Fitness Training*. Washington DC: Department of the Army, 1973.
- _____. FM 21-20, *Physical Fitness Training*. Washington DC: Department of the Army, 1980.
- _____. FM 21-20, *Physical Fitness Training*. Washington DC: Department of the Army, 1992.
- _____. FM 25-100, *Training the Force*. Washington DC: Department of the Army, 1990.
- _____. FM 25-101, *Battle Focused Training*. Washington DC: Department of the Army, 1990.
- _____. FM 57-220, *Basic Parachuting Techniques and Training*. Washington, DC: Department of the Army, 1990.
- _____. FM 101-5, *Staff Organizations and Operations*. Washington DC: Department of the Army, 1997.
- _____. STP 7-11BCHM-SM-TG, *Soldier's Manual and Trainer's Guide..* Washington, DC: Department of the Army, 1989.
- _____. STP 21-1-SMCT, *Soldier's Manual of Common Tasks*. Washington, DC: Department of the Army, 1994.
- Headquarters, 75th Ranger Regiment. RTC 350-1: *Training*. Fort Benning, GA: 75th Ranger Regiment, 1998.
- _____. RTC 350-2: *Advanced MOUT Training*. Fort Benning, GA: 75th Ranger Regiment, 1997.
- _____. RTC 350-4: *Water Training Standing Operating Procedures*. Fort Benning, GA: 75th Ranger Regiment, 1996.

Unpublished Sources

- Department of the Army. "Assessing the Physical Demands and Direct Combat Probability of United States Organizations, Military Occupational Specialties and Duty Positions." Fort Monroe, VA: United States Army Training and Doctrine Command, 1981. NTIC, ADE 751043.
- Hertling, Mark P. "Physical Training for the Modern Battlefield: Are We Tough Enough?" School of Advanced Military Studies Monograph, Fort Leavenworth, KS: U.S. Army Command and General Staff College, 1987.
- Knapik, Joseph, and Frederick Drews. Technical Report 3-87, "Influence of a Specific Light Infantry Physical Training Program on Physical Fitness." Carlisle Barracks, PA: Army Physical Fitness Research Institute, 1987.
- Larsen, James C. "Initiative Oriented Training." Master of Military Art and Science Thesis, Fort Leavenworth, KS: U.S. Army Command and General College, 1998.
- McLean, John E. II. "The Amphibious Assault: How Fit Are Our Marines for the Mission?" Master of Military Art and Science Thesis, Fort Leavenworth, KS: U.S. Army Command and General Staff College, 1992.
- Mello, Robert P., Michelle Murphy, and James A. Vogel. "Relationship Between a Two Mile Run For Time and Maximal Oxygen Uptake." Natick, MA: U.S. Army Research Institute of Environmental Medicine, 1987. NTIS, AD-A179343.
- Myles, W. S., J. I. Pope, and D. B. Van Loon. Defence and Civil Institute of Environmental Medicine Report 85-R-08, "An Evaluation of the Canadian Forces Battle Efficiency Test." Ontario, Canada: Defence and Civil Institute of Environmental Medicine, 1985.
- Sharp, Marilyn, John F. Patton, and James A. Vogel. Technical Report T98, "A Database of Physically Demanding Tasks Performed by U.S. Army Soldiers." Natick, MA: U.S. Army Research Institute of Environmental Medicine, 1998.
- Tomasi, Louis F., et al. "1995 Army Physical Fitness Test Update Survey." Fort Benning, GA: U.S. Army Physical Fitness School, 1998.
- Townsend, Stephen J. "The Factors of Soldier's Load." Master of Military Art and Science Thesis, Fort Leavenworth, KS: U.S. Army Command and General Staff College, 1994.

Other Sources

American Heritage Dictionary, 2d ed. Boston: Houghton Mifflin Company, 1982

INITIAL DISTRIBUTION LIST

1. Combined Arms Research Library
U.S. Army Command and General Staff College
250 Gibbon Ave.
Fort Leavenworth, KS 66027-2314
2. Defense Technical Information Center/OCA
8725 John J. Kingman Rd., Suite 944
Fort Belvoir, VA 22060-6218
3. Major James C. Larsen
1353 West Rhett Butler Drive
Clarksville, TN 37042
4. LTC Richard C. Bullis
Center for Army Leadership
USACGSC
250 Gibbon Avenue
Fort Leavenworth, KS 66027-1352
5. Mr. Larry McNown
Department of Community Activities
600 Thomas Avenue
Fort Leavenworth, KS 66027-1352

CERTIFICATION FOR MMAS DISTRIBUTION STATEMENT

1. Certification Date: 4 June 1999
2. Thesis Author: Major Mark Lee Walters
3. Thesis Title: Fitness Requirements of the 75th Ranger Regiment: Are They Relevant?

4. Thesis Committee Members

Signatures:

James Clansen
Richard [unclear]
Larry McDown

5. Distribution Statement: See distribution statements A-X on reverse, then circle appropriate distribution statement letter code below:

A B C D E F X

SEE EXPLANATION OF CODES ON REVERSE

If your thesis does not fit into any of the above categories or is classified, you must coordinate with the classified section at CARL.

6. Justification: Justification is required for any distribution other than described in Distribution Statement A. All or part of a thesis may justify distribution limitation. See limitation justification statements 1-10 on reverse, then list, below, the statement(s) that applies (apply) to your thesis and corresponding chapters/sections and pages. Follow sample format shown below:

EXAMPLE

<u>Limitation Justification Statement</u>	<u>/</u>	<u>Chapter/Section</u>	<u>/</u>	<u>Page(s)</u>
Direct Military Support (10)	/	Chapter 3	/	12
Critical Technology (3)	/	Section 4	/	31
Administrative Operational Use (7)	/	Chapter 2	/	13-32

Fill in limitation justification for your thesis below:

<u>Limitation Justification Statement</u>	<u>/</u>	<u>Chapter/Section</u>	<u>/</u>	<u>Page(s)</u>
_____	/	_____	/	_____
_____	/	_____	/	_____
_____	/	_____	/	_____
_____	/	_____	/	_____
_____	/	_____	/	_____

7. MMAS Thesis Author's Signature:

Mark Lee Walters

STATEMENT A: Approved for public release; distribution is unlimited. (Documents with this statement may be made available or sold to the general public and foreign nationals).

STATEMENT B: Distribution authorized to U.S. Government agencies only (insert reason and date ON REVERSE OF THIS FORM). Currently used reasons for imposing this statement include the following:

1. Foreign Government Information. Protection of foreign information.
2. Proprietary Information. Protection of proprietary information not owned by the U.S. Government.
3. Critical Technology. Protection and control of critical technology including technical data with potential military application.
4. Test and Evaluation. Protection of test and evaluation of commercial production or military hardware.
5. Contractor Performance Evaluation. Protection of information involving contractor performance evaluation.
6. Premature Dissemination. Protection of information involving systems or hardware from premature dissemination.
7. Administrative/Operational Use. Protection of information restricted to official use or for administrative or operational purposes.
8. Software Documentation. Protection of software documentation - release only in accordance with the provisions of DoD Instruction 7930.2.
9. Specific Authority. Protection of information required by a specific authority.
10. Direct Military Support. To protect export-controlled technical data of such military significance that release for purposes other than direct support of DoD-approved activities may jeopardize a U.S. military advantage.

STATEMENT C: Distribution authorized to U.S. Government agencies and their contractors: (REASON AND DATE). Currently most used reasons are 1, 3, 7, 8, and 9 above.

STATEMENT D: Distribution authorized to DoD and U.S. DoD contractors only; (REASON AND DATE). Currently most reasons are 1, 3, 7, 8, and 9 above.

STATEMENT E: Distribution authorized to DoD only; (REASON AND DATE). Currently most used reasons are 1, 2, 3, 4, 5, 6, 7, 8, 9, and 10.

STATEMENT F: Further dissemination only as directed by (controlling DoD office and date), or higher DoD authority. Used when the DoD originator determines that information is subject to special dissemination limitation specified by paragraph 4-505, DoD 5200.1-R.

STATEMENT X: Distribution authorized to U.S. Government agencies and private individuals of enterprises eligible to obtain export-controlled technical data in accordance with DoD Directive 5230.25; (date). Controlling DoD office is (insert).