

ARMY RESEARCH LABORATORY

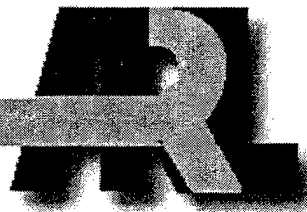

Design and Flight Test of a Prototype Range Control Module for an 81-mm Mortar

Michael S.L. Hollis
Fred J. Brandon
Peter C. Muller

ARL-MR-463

SEPTEMBER 1999

19990917 011

DTIC QUALITY INSPECTED 4

Approved for public release; distribution is unlimited.

The findings in this report are not to be construed as an official Department of the Army position unless so designated by other authorized documents.

Citation of manufacturer's or trade names does not constitute an official endorsement or approval of the use thereof.

Destroy this report when it is no longer needed. Do not return it to the originator.

Army Research Laboratory

Aberdeen Proving Ground, MD 21005-5066

ARL-MR-463

September 1999

Design and Flight Test of a Prototype Range Control Module for an 81-mm Mortar

Michael S.L. Hollis
Fred J. Brandon
Peter C. Muller
Weapons and Materials Research Directorate

Approved for public release; distribution is unlimited.

Abstract

The primary purpose of the Light Forces Program is to improve the effectiveness of fire from the infantry mortar. Advances in microelectronics, sensors, and power supplies make it possible to design and build a miniature, one-dimensional, range correction module (RCM) for the mortar. This report focuses on the flight testing of an RCM prototype device for the 81-mm mortar. The objective of testing the concept was to demonstrate the structural integrity and the drag authority of the design. Based on the experimental data, it can be seen that the undeployed range control modules do not affect the overall drag of the projectile. It can also be seen that when the RCM deploys, it has a significant effect on range. Experimental data obtained from the test indicate that the undeployed RCM does not change the ballistic characteristics of the shell; however, when deployed, the RCM does provide a significant method of controlling range.

ACKNOWLEDGMENTS

The authors wish to express gratitude to those people who contributed to the success of the program. The people of the Aberdeen Test Center, under the direction of Eric Rajkowski, are to be recognized for conducting the firing test. In addition, those who aided in the design and fabrication of the electrical and mechanical hardware are appreciated. Keith Dougherty and William Pennington are to be praised for their expertise in fabricating the mechanical hardware. Finally, Eugene Ferguson and Craig Myers are to be commended for their design work and electrical fabrication.

INTENTIONALLY LEFT BLANK

TABLE OF CONTENTS

	<u>Page</u>
LIST OF FIGURES	vii
LIST OF TABLES	ix
1. INTRODUCTION	1
2. BACKGROUND	1
3. DESIGN	4
3.1 Mechanical Design	4
3.2 Aerodynamic Analysis	5
4. ELECTRICAL DESIGN	7
5. FLIGHT TEST	8
5.1 Setup	8
5.2 Results	10
5.3 Failure Analysis	12
6. CONCLUSION	12
REFERENCES	15
DISTRIBUTION LIST	17
REPORT DOCUMENTATION PAGE	23

INTENTIONALLY LEFT BLANK

LIST OF FIGURES

<u>Figure</u>		<u>Page</u>
1.	Error "Budget" for a Ballistic Projectile	2
2.	An M889 Mortar With a Standard Point-Detonating M935 Fuze	2
3.	An M889 Mortar and M935 Fuze With a Range Correction Module	2
4.	Detailed View of the Deployed Range Correction Module	3
5.	The Exploded Assembly View of the Prototype Range Correction Module for a Mortar	4
6.	Range and Deflection Errors	5
7.	Drag Coefficient Versus Mach Number	6
8.	Predicted Range Versus Deployment Time for the Five RCMs	7
9.	Circuit Schematic	8
10.	RCM Assembly	9
11.	An M889E1 Projectile With Charge and RCM Installed	9
12.	Radial Velocities of First Control Round and RCM That Deployed	11
13.	Change in Drag for the RCM That Deployed	12

INTENTIONALLY LEFT BLANK

LIST OF TABLES

<u>Table</u>		<u>Page</u>
1.	Physical Properties of Projectile Assemblies	10
2.	Flight Data of the Projectiles	11

INTENTIONALLY LEFT BLANK

DESIGN AND FLIGHT TEST OF A PROTOTYPE RANGE CONTROL MODULE FOR AN 81-MM MORTAR

1. INTRODUCTION

The primary purpose of the Light Forces Program is to improve the effectiveness of fire from the infantry mortar. Advances in microelectronics, sensors, and power supplies make it possible to design and build a miniature, one-dimensional, range correction module (RCM) for indirect fire weapons, i.e., mortar and artillery. The Advanced Munitions Concepts Branch of the Ballistics and Weapons Concepts Division, Weapons and Materials Research Directorate of the U.S. Army Research Laboratory (ARL), has been doing design work in the area of self-correction devices for artillery since 1996. Recent reports such as "Low Cost Competent Munitions (LCCM) Self-Correction Devices—An Initial Study and Status" and "Preliminary Design of a Range Correction Module for an Artillery Shell" demonstrate the branch's interest in improving the ballistic accuracy of artillery projectiles (D'Amico 1996; Hollis 1996). The design of the RCM has been patented under U.S. Patent No. 5,762,291.

This report focuses on the flight testing of an RCM prototype device for the 81-mm mortar. The objective of testing the concept was to demonstrate the structural integrity and the drag authority of the RCM design. Since these were the main objectives, the amount of electronics and their complexity was kept to a minimum. The concept was demonstrated using a fixed value timing circuit powered by nickel-cadmium batteries. The timing circuit allows the drag mechanism to be released at a predetermined time in flight.

2. BACKGROUND

Figure 1 shows a simplified error "budget" for a typical indirect fire ballistic weapon system. The ellipse represents the impact area of the projectile. The major axis of the oval depicts range error, whereas the minor axis symbolizes the error attributable to deflection. The intent of the RCM is to reduce the range error to about that of the deflection error, thus providing a simple smart munition capability which increases lethality. The RCM is placed between the mortar projectile body and the fuze. The fuze does not require modification and maintains normal fuze function. The module is designed to minimize effects on the aerodynamic characteristics of the projectile. Miniaturization of the device is imperative in order to reduce the impact in logistics and cost. Figure 2 depicts a model of an 81-mm, M889 mortar with a point-detonating M935 fuze, and Figure 3 displays the same mortar with the RCM.

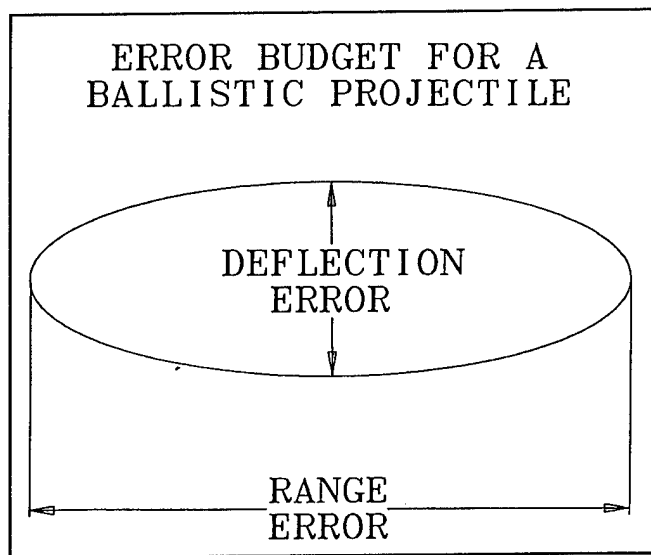

Figure 1. Error "Budget" for a Ballistic Projectile.



Figure 2. An M889 Mortar With a Standard Point-Detonating M935 Fuze.



Figure 3. An M889 Mortar and M935 Fuze With a Range Correction Module.

A booster cup, which normally screws into the fuze, now screws into the module opposite the fuze. A small hollow tube, which runs down the center of the device, allows the ignition flame from the fuze to ignite the charge in the booster cup. Enhancement of this process may be necessary, but it is unknown at this time.

Extending the fuze, as seen in Figure 3, may have some effect on the aerodynamics of the projectile, but the design should maintain the existing ballistic coefficient. The aerodynamic effects were minimized by designing the RCM with a cylindrical shape. The diameter of the cylinder is equal to that of the largest diameter of the fuze.

Figure 4 shows a detailed view of the RCM in the deployed configuration. Depicted are small flat planar surfaces or flare tabs. The effect in flight is to create more drag on the projectile. A more definitive explanation of an RCM concept for a mortar is as follows. The device is attached to the projectile between the body and the fuze, while in the field. An on-board central processing unit (CPU) is preprogrammed with the target location and the firing location coordinates. The mortar is then aimed to fire beyond the target location. An on-board inertial measurement unit (IMU) will determine the range error with respect to the target while the projectile is in flight. The CPU predicts the amount of excessive range that the shell will have. At a certain time in flight chosen by the CPU, the flare tabs will deploy to correct the "overshoot," thus reducing the range error aspect of the flight.

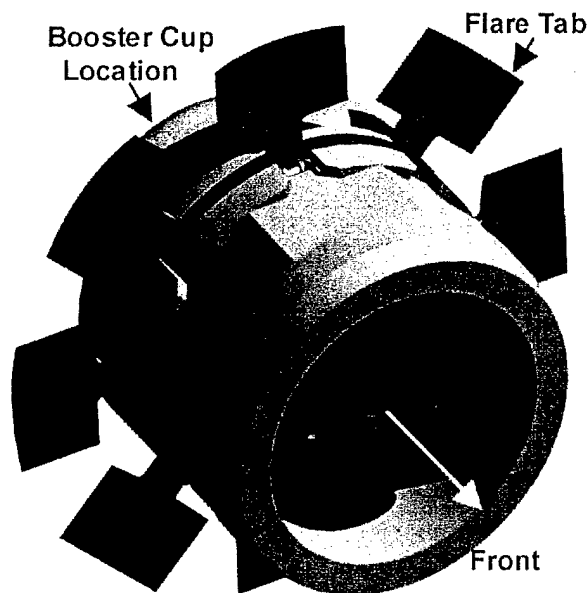

Figure 4. Detailed View of the Deployed Range Correction Module.

3. DESIGN

3.1 Mechanical Design

The prototype mechanical design consists of many parts, several of which are spring loaded and moving in concert. Figure 5 displays an exploded view of the prototype design.

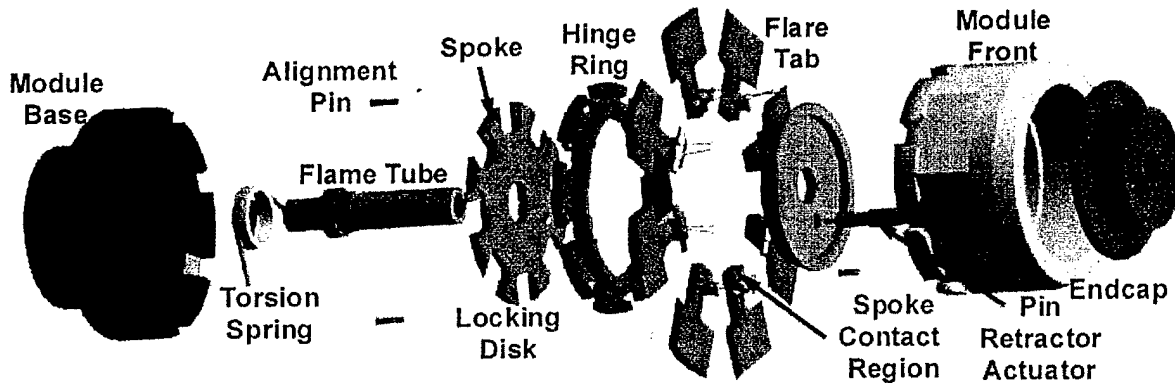

Figure 5. The Exploded Assembly View of the Prototype Range Correction Module for a Mortar.

Installation into the mortar body is simple since the module base has the same threads as a standard fuze. The assembled device extends the fuze from the body by 1.6 inches (40.6 mm).

During a launch, the stacking approach used to assemble the device carries the set-back loads. Alignment pins maintain proper positioning of the module base, the hinge ring, and the module front. The flame tube is crucial to provide support during the rebound loads and the balloting loads of the launch. One end of the flame tube threads into the module base, whereas the other end threads into the end cap. As the end cap turns about the flame tube, the entire assembly is clamped together.

Eight flare tabs provide the actual means of range correction by increasing the overall drag of the projectile when deployed. The flare tabs are originally locked in place, flush with the module front, as seen in Figure 3. In this position, the tabs create a cylindrical surface that will have the least effect on the aerodynamics of the projectile. The flare tabs are locked by means of an internal locking disk, as seen in Figure 5. The spokes of the locking disk push on the underside of the flare tabs. The locking disk is pre-loaded via a torsion spring. The pin of the pin retractor actuator, which is an electro-explosive device (EED), maintains the locking disk in the pre-loaded or locked position. At the desired time in flight, the pin retractor actuator will retract its pin, freeing the locking disk and allowing it to rotate. The flare tabs, which are also individually

spring loaded, will rotate through the slots in the locking disk. As the flare tabs pivot to the deployed 90°, the spokes of the locking disk, which are beveled, will slide under the flare tabs. This locks the tabs in the deployed position. This prototype, however, is not a final solution. Smaller clock-like mechanisms could be designed to allow more room for electronics.

This report focuses on one specific RCM concept and its flight test. Detailed mechanical design of the flare tab mechanisms, the electronics volume, and the structural analysis of the overall design are presented in ARL-MR-411 (Hollis 1998).

3.2 Aerodynamic Analysis

The largest error in munition precision is the range error. Figure 6 displays the errors for range and deflection for the 81-mm, M889, high explosive (HE) mortar projectile. It can be seen that the range error is more than double the deflection error.

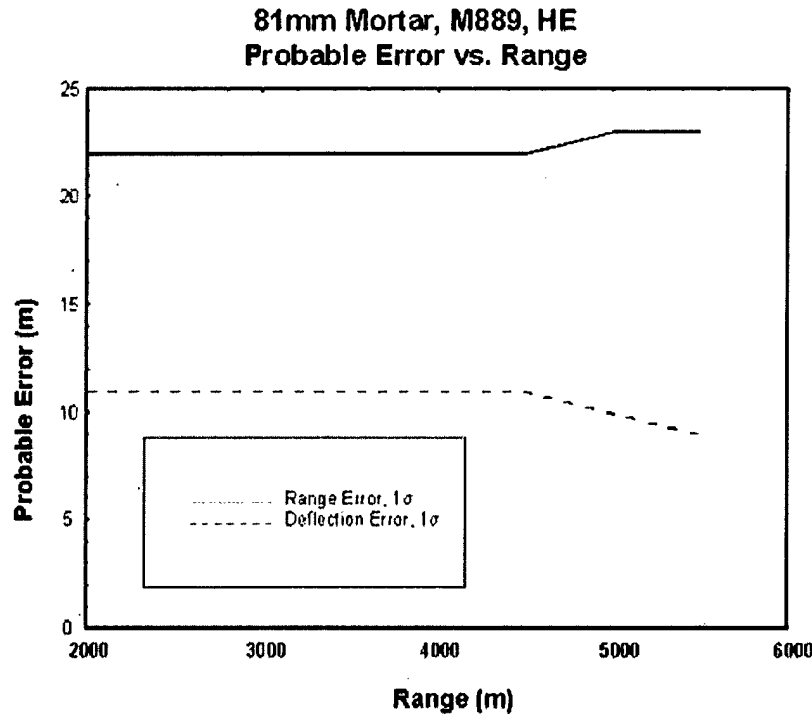

Figure 6. Range and Deflection Errors.

A comparison of the ballistic trajectories of both the standard and modified projectiles is a means of determining range control authority of the RCM. One must compare the trajectories of projectiles during the time of deployment to the time of impact. Initially, a ballistic match

between pre-deployed, modified, and standard projectiles is necessary. A ballistic match between two projectiles requires equal ratios of drag to mass. The cylindrical geometry of the pre-deployed RCM has little or no effect on drag, provided the projectile does not yaw more than 5°. Therefore, the masses of both the unmodified and modified projectiles must be nearly the same. At the time of flight testing, the masses of the modified and unmodified projectiles did not vary significantly.

The drag and aerodynamic coefficients for a projectile with an RCM were derived through the use of an empirical/theoretical computer program (projectile design and analysis system [PRODAS]). Notice that in Figure 7, C_D for the subsonic region of the deployed RCM is approximately 0.52, compared to 0.13 for a standard or undeveloped, modified projectile.

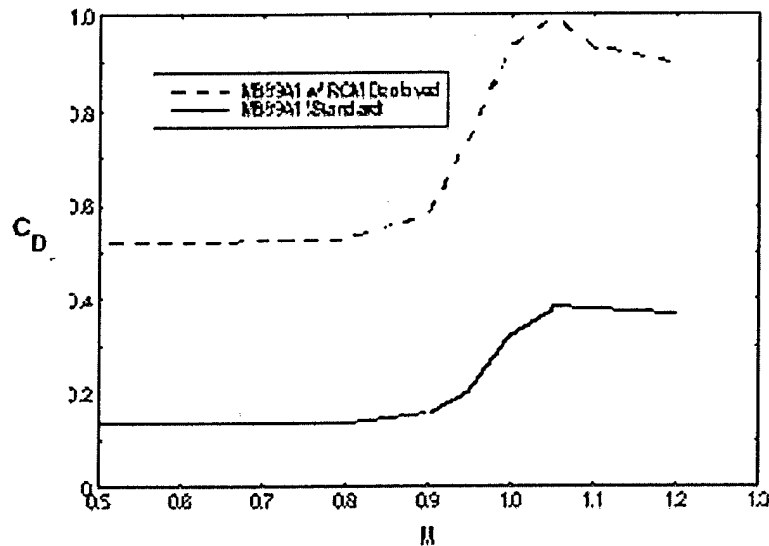

Figure 7. Drag Coefficient Versus Mach Number.

Knowing the predicted drag of the projectile for both undeveloped and deployed RCMs and using a six-degree-of-freedom (6 DOF) simulation program, one can predict the range of the projectile for any time of deployment of the RCM. For the purpose of the simulation, a 15-second deployment time, a quadrant of elevation of 891 mils, and a muzzle velocity of 304 m/s were chosen. Using these values, we predicted a 750-meter difference in range.

The electronic timers of the prototype RCMs were set as close to 15 seconds as possible. Because of minor variations in the clock frequency, the deployment times fell short of the desired value of 15 seconds, varying from 14.04 to 14.6 seconds. Using the computer model, we

calculated the predicted ranges for the delay values for each of the RCMs. Figure 8 displays the predicted ranges for the five RCMs that were fabricated. The nominal range of the M889A1 under the same conditions is 5700 meters (TACOM-ARDEC, June 1997).

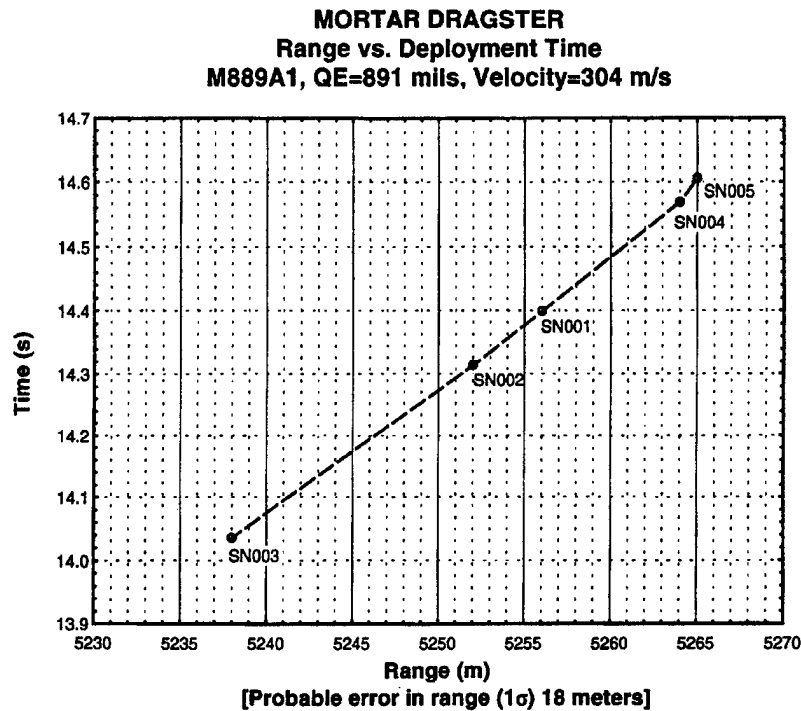

Figure 8. Predicted Range Versus Deployment Time for the Five RCMs.

4. ELECTRICAL DESIGN

The electronics contained in the RCM had two functions. The first was to activate the electronics at launch, and the second was a timing circuit to fire the EED at a predetermined time in flight.

The activating circuitry consisted of a g-switch and a silicon-controlled rectifier (SCR) switch circuit. The g-switch was a 1000-g momentary contact type made by Aerodyne Controls Corporation. This switch applied the stimulus at launch, which allowed the power supply to turn on the SCR. Once turned on, an SCR will stay on as long as power is applied to its input. To prevent the loss of power to the circuitry during a momentary battery contact failure, the output of the SCR was fed back to its gate through a storage capacitor. This allowed the circuit to ride through power glitches of as much as 1/2 second.

data are derived. In order to check the integrity of the RCM, a Kodak 4540 high-speed motion-analysis camera system provided an image of each projectile about 30 feet after the projectile exited the muzzle. Five inert M889E1 rounds (two at Charge 3, 110 mils' quadrant of elevation [QE]; one at Charge 4, 1100 mils' QE; then two at Charge 4 at 891 mils' QE) were fired to seat the base plate and verify proper operation of the test instrumentation. All test cartridges were fired from a ground-mounted M252 mortar at 891 mils' QE. Each RCM was also subjected to an electronic diagnostic test at the firing range before assembly onto the projectile body. During the diagnostic check, it was noted that the timers were faster than when previously measured in the laboratory. The clocks were 0.2 second faster on the average. The RCMs were threaded onto the modified projectile body in place of the fuze and hand tightened (Aberdeen Test Center 1998).

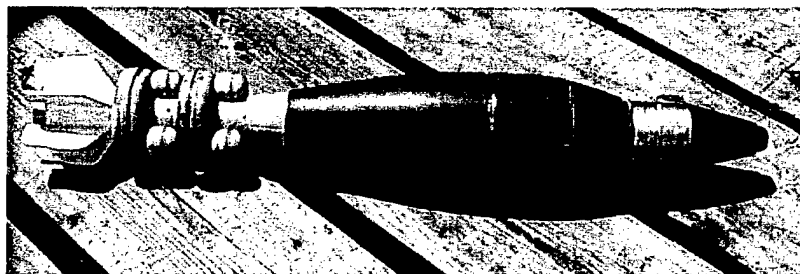

Figure 10. RCM Assembly.

Figure 11. M889E1 Projectile With Charge and RCM Installed.

5.2 Results

Physical properties of all five RCMs and M889E1 projectile assemblies were obtained and are listed in Table 1. Notice that the combined length of the modified projectiles is 1.6 inches longer than a standard projectile and fuze. In addition, the average weight of the modified projectiles is 9.34 lb, compared to an average standard weight of about 9.28 lb.

Table 1. Projectile Assembly Physical Properties

Round No.	Bourrelet Diameter (in.)		Length (in.)	Weight (Lb) W/Fuze	CG From Base	Moment of Inertia (lb-in ²)	
	0°	180°				Axial	Transverse
1	0°	3.120	20.86	9.34	11.93	140.692	11.175
	180°	3.120					
2	0°	3.120	20.86	9.31	11.93	141.2754	11.175
	180°	3.120					
3	0°	3.120	20.89	9.37	11.94	141.0809	11.246
	180°	3.120					
4	0°	3.120	20.90	9.33	11.93	141.5673	11.246
	180°	3.119					
5	0°	3.120	20.86	9.33	11.93	140.4005	11.246
	180°	3.120					

Even though five RCMs were intended to be tested, only four were flown. During the flight test, the first two RCMs did not deploy. A playback of video from the Kodak 4540 indicated RCM sound structural integrity during launch. It was then decided to fire two more RCMs and reserve one unit for test under laboratory conditions with an IMPAC shock table. Only one of the last two devices deployed. Table 2 displays the flight data of the projectiles that were fired. Notice the similarity of the ranges for the modified projectiles and the standard projectiles. More importantly, notice that the change in range on the projectile that deployed the RCM is on the order of 850 meters.

Figure 12 is a plot of the radial velocities of the first control round (001) and the RCM (006) that deployed. Note the change in velocity that occurs at about 13.8 seconds, which was the predetermined time for the deployment. Figure 13 displays the dramatic change in drag for the deployed RCM. The drag coefficient for that RCM was 0.48. In addition, notice how similar in drag the failed RCMs are to the control rounds. The drag coefficient for both the undeployed RCM and standard projectiles is about 0.13.

Table 2. Projectile Flight Data

Round No.	Muzzle Velocity (m/s)	Time of Flight (sec)	Range (m)	Deflection (m)	Comment
1	300.95	40.62	5744.32	-99.83	Standard
2	298.75	40.28	5667.00	-121.60	Fail
3	301.33	40.76	5769.16	-111.11	Standard
4	300.63	40.61	5698.49	-114.76	Fail
5	301.13	40.79	5762.89	-115.77	Standard
6	299.89	42.19	4841.55	-84.05	Deploy
7	301.99	40.85	5770.50	-90.70	Standard
8	300.66	40.68	5692.89	-121.37	Fail

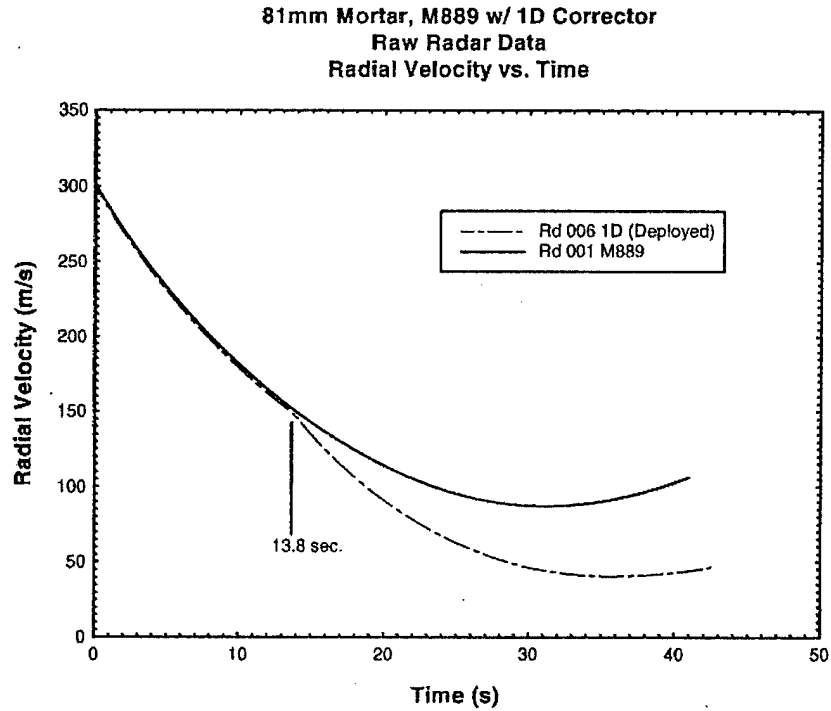

Figure 12. Radial Velocities of First Control Round and RCM That Deployed.

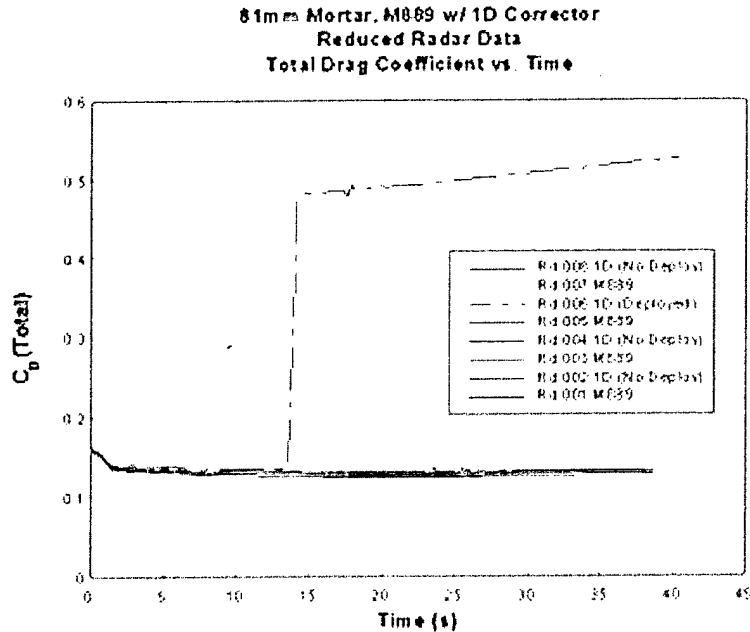

Figure 13. Change in Drag for the RCM That Deployed.

5.3 Failure Analysis

In an attempt to determine the cause of malfunction, the authors subjected the remaining RCM unit to a series of tests. The device was first photographed with X-rays at various points of view and intensities in an effort to ascertain anything peculiar. Since several electrical test points were built into the RCM, electrical diagnostics were also performed. Everything was verified, which led to placing the device in a fixture and subjecting it to an axial shock load equal in magnitude to that of the set-back load for the M889E1 mortar projectile. The device had been previously tested on the shock table with shock loads as high as 15,000 g's for 0.0001 second. However, the entire assembly, including g-hardened electronics, had not been shocked. With electrical leads now attached to the test points, the RCM was shocked with approximately 12,000 g's. Almost 15 seconds later, the flare tabs deployed. The resulting deployment of the device left the cause for the three malfunctioning RCMs undetermined.

6. CONCLUSION

A design study and flight test demonstration were conducted to determine the range control authority of a simple range control module. The module was designed to be added to a mortar shell without requiring modifications of the components. The studies indicate that it would be possible to mechanically change the drag at desired times during a flight to significantly shorten the normally

expected range. Based on predicted data and a detailed metal parts design, five RCM units were built and flight tested. Of the four units that were fired, only one functioned as planned.

Although one successful deployment may not completely validate this experiment, it does provide insight to the amount of range control that can be accomplished. The experimental drag coefficient obtained from the one round of 0.48 (see Figure 13) is slightly less than the predicted value of about 0.52 (see Figure 7). The mortar shell achieved an 850-meter reduction in range when its RCM deployed at 13.8 seconds. Unfortunately, detailed examination of the unfired RCM unit failed to provide any information as to why three of the flight units did not deploy.

Based on the design study and the test data obtained, it can be seen that the undeployed range control modules with the mortar shell had very little effect on the overall drag of the projectile. It can also be seen that when the RCM deploys, it will have a significant effect on range, depending on the time of deployment.

INTENTIONALLY LEFT BLANK

REFERENCES

- Condon, J.A., and M. Hollis, "Dynamic Analyses of the Mortar Dragster Tab Mechanism," ARL-TN-107, U.S. Army Research Laboratory, Aberdeen Proving Ground, MD, April 1998.
- D'Amico, W. "Low Cost Competent Munitions (LCCM) Self-Correction Devices—An Initial Study and Status," ARL-TR-1178, U.S. Army Research Laboratory, Aberdeen Proving Ground, MD, August 1996.
- Hollis, M. "Preliminary Design of a Range Correction Module for an Artillery Shell," ARL-MR-298, U.S. Army Research Laboratory, Aberdeen Proving Ground, MD, March 1996.
- Hollis, M. "Design and Analysis of a Prototype Range Correction Device for a Mortar Projectile," ARL-MR-411, U.S. Army Research Laboratory, Aberdeen Proving Ground, MD, August 1998.
- Arrow Tech Associates, "PRODAS (Version 3.9)," Copyright 1990-1995.
- US TACOM-ARDEC, "Firing Tables for Mortar, 81-mm, M252," FT 81-AR-2, Firing Tables and Aeroballistic Branch, June 1997.
- Rajkowski, Eric. "Test Record," Test Record No. LS-00208, TECOM Project No. 2-MU-001-RCD-001, U.S. Army Aberdeen Test Center, Aberdeen Proving Ground, MD, August 1998.

INTENTIONALLY LEFT BLANK

<u>NO. OF COPIES</u>	<u>ORGANIZATION</u>
2	ADMINISTRATOR DEFENSE TECHNICAL INFO CENTER ATTN DTIC OCP 8725 JOHN J KINGMAN RD STE 0944 FT BELVOIR VA 22060-6218
1	DIRECTOR US ARMY RESEARCH LABORATORY ATTN AMSRL CS AS REC MGMT 2800 POWDER MILL RD ADELPHI MD 20783-1197
1	DIRECTOR US ARMY RESEARCH LABORATORY ATTN AMSRL CI LL TECH LIB 2800 POWDER MILL RD ADELPHI MD 207830-1197
1	DIRECTOR US ARMY RESEARCH LABORATORY ATTN AMSRL DD J J ROCCHIO 2800 POWDER MILL RD ADELPHI MD 20783-1197
4	DIRECTOR US ARMY RSRCH LAB ATTN AMSRL SS SM J EIKE J GERBER A LADAS G WILES 2800 POWDER MILL RD ADELPHI MD 20783-1145
2	DIR US ARMY CECOM ATTN AMSEL RD C2 CS DR J VIG DR R FILLER FT MONMOUTH NJ 07703-5601
1	COMMANDER US ARMY RSRCH OFC ATTN AMXRO RT IP TECH LIB PO BOX 122 11 RSCH TRIANGLE PARK NC 27709-2211
15	CMDR US ARMY ARDEC ATTN AMSTA AR AET A M AMORUSO E BROWN C CHUNG A FARINA J GRAU S KAHN K KENDL C LIVECCHIA C NG G MALEJKO W TOLEDO B WONG J THOMASOVICH AMSTA AR AET C S LONGO AMSTA AR FZ L SPRINGER PICATINNY ARSENAL NJ 07806-5000

<u>NO. OF COPIES</u>	<u>ORGANIZATION</u>
7	CMDR US ARMY ARDEC ATTN AMSTA FSP A S DEFA0 N GRAY V ILLARDI S SARULLO R SICIGNANO D COLLET R WERKO PICATINNY ARSENAL NJ 07806-5000
1	COMMANDER USA DUGWAY PROV GRND ATTN TECH LIB DUGWAY UT W22
1	COMMANDER USA YUMA PROV GRND ATTN STEYT MT EA C HASTON YUMA AZ 85365-9110
1	COMMANDER USA YUMA PROV GRND ATTN STEPY RS EL A HOOPER YUMA AZ 85365-9110
1	COMMANDER US ARMY MISSILE COMMAND ATTN AMSMI RD W WALKER REDSTONE ARSENAL AL 35898-5000
2	DIRECTOR US ARMY RTTC ATTN STERT TE F TD R EPPS K WHIGHAM BLDG 7855 REDSTONE ARSENAL AL 35898-8052
3	COMMANDER NAVAL SURFACE WARFARE CTR ATTN TECH LIB D HAGEN J FRAYSEE 17320 DAHLGREN RD DAHLGREN VA 22448-5150
3	COMMANDER NAWC WPN DIV TT&I SYS DPT ATTN CODE 3904 D SCOFIELD CODE 543400D S MEYER CODE 54A000D S GATTIS 1 ADMINISTRATION CIRCLE CHINA LAKE CA 93555-6100
1	OFFICER IN CHARGE NAVAL EOD FACILITY ATTN TECH LIB INDIAN HEAD MD 20640

<u>NO. OF COPIES</u>	<u>ORGANIZATION</u>	<u>NO. OF COPIES</u>	<u>ORGANIZATION</u>
1	ROCKWELL INTL CORP AUTONETICS ELECTR SYS DIV ATTN R CHRISTIANSEN 3370 MIRALOMA AVE PO BOX 3105 ANAHEIM CA 92803-3105	1	CG TACOM ARDEC MCLO ATTN MAJ MURRAY BLDG 1 PICATINNY ARSENAL NJ 07806-5000
2	CHLS STARK DRAPER LAB INC ATTN J ELWELL J SITOMER 555 TECHNOLOGY SQUARE CAMBRIDGE MA 02139-3563	4	CDR US ARMY ARDEC ATTN AMSTA AR DSA MO ED LEWIS P BURKE A WOOD P FELTH PICATINNY ARSENAL NJ 07806-5000
1	INTERSTATE ELECTR CORP ATTN J GRACE 1001 E BALL RD ANAHEIM CA 92803	1	CDR US ARMY ARDEC ATTN AMSTA AR FSA M RANDY HAND PICATINNY ARSENAL NJ 07806-5000
1	INTERSTATE ELECTR CORP ATTN I REIDER 1735 JEFFERSON DAVIS HWY STE 905 ARLINGTON VA 22202	1	CDR US ARMY ARDEC ATTN AMSTA AR FSA D BOB WORTH PICATINNY ARSENAL NJ 07806-5000
2	DYNAMIC SCIENCE INC ATTN S ZARDAS P NEUMAN PO BOX N ABERDEEN MD 21001	1	CDR US ARMY ARDEC ATTN AMSTA AR FSP G DAVE PANHORST PICATINNY ARSENAL NJ 07806-5000
3	ARROW TECH ASSOCIATES INC ATTN W HATHAWAY JOHN WHYTE R WHYTE 1233 SHELBOURNE RD STE D8 SOUTH BURLINGTON VT 05403	2	CDR US ARMY ARDEC ATTN AMSTA AR FSP Z MATT CILLI MIKE ENNIS PICATINNY ARSENAL NJ 07806-5000
1	PICO SYSTEMS INC ELECTRONIC PKG & TECH DEPT ATTN J BANKER PO BOX 134001 ANN ARBOR MI 48113-4001	1	CDR USMC MARCORSSYSCOM ATTN MAJ BRUCE MARTIN QUANTICO VA 22134
1	ROCKWELL INTNL CORP COMM DIV ATTN D DEALE 350 COLLINS RD NE CEDAR RAPIDS IA 52498	1	TAP/AIRCRAFT INSTRUMENTATION DIV ATTN R FAULSTICH 5.4.2 UNIT 1 47765 RANCH ROAD NAVAL AIR WARFARE CTR AIRCRAFT DIVISION PATUXENT RIVER MD 20670-1469
2	CDR US ARMY INFANTRY CENTER ATTN ATZB CDF LTC DOUG LITAVEC FT BENNING GA 31905-5800	1	DIR RSCH & LABORATORY MGMT DEPUTY ASST SECY (RES & TECH) ATTN SARD TR RICK MORRISON 2511 JEFFERSON DAVIS HWY SUITE 9000 ARLINGTON VA 22202-3911
1	CDR US ARMY INFANTRY CENTER ATTN ATZB WC CHRIS KEARNS FT BENNING GA 31905-5400	3	CMDR US ARMY ARDEC ATTN ADAWS ARDEC M MATTICE D CARLUCCI MCATD ARDEC NIGEL GRAY PICATINNY ARSENAL NJ 07806-5000
		1	ANALOG DEVICES ATTN ROBERT MEISENHOLDER 804 WOBURN ST WILMINGTON MA 01887-3462

<u>NO. OF COPIES</u>	<u>ORGANIZATION</u>	<u>NO. OF COPIES</u>	<u>ORGANIZATION</u>
1	MCC ATTN ROBERT MIRACKI 3500 W BALCONES CENTER AUSTIN TX 78759-5398	1	JOHN EBERSOLE CREATIVE OPTICS 360 STATE ROUTE 101 BEDFORD NH 03110-5031
1	DAVID PAREKH 7220 RICHARDSON RD SMYRNA GA 30080	1	DRAPER LABORATORY ATTN JOHN ELWELL 555 TECHNOLOGY SQUARE CAMBRIDGE MA 02139
3	STRICOM ATTN AMSTI LL M PHILLIPS STRICOM EL D SCHNEIDER RONALD COLANGELO 12350 RESEARCH PARK ORLANDO FL 32826-3276	2	IOA INST FOR DEFENSE ANALYSIS ATTN JOHN FRASIER RICHARD SINGER 1801 N BEAUREGARD ST ALEXANDRIA VA 22311-1772
1	US ARMY RESEARCH LABORATORY ATTN AMSRL SE RL B PIEKARSKI ADELPHI MD 20783-1197	1	NSWC/IHDIV ATTN CODE 40D D GARVICK 101 STRAUSS AVE INDIAN HEAD MD 20640-5035
1	DARPA ATTN ALBERT PISANO 3701 N FAIRFAX DRIVE ARLINGTON VA 22203-1714	1	TEXAS INSTRUMENTS ATTN TOMMY HICKS 8816 CROSSWIND DRIVE FORT WORTH TX 76719
1	SRS TECHNOLOGIES ATTN JACK SUDDRETH 3900 FAIRFAX DRIVE ARLINGTON VA 22203	1	IMI INC ATTN THOR JUNEAU 2140 SHATTUCH AVE BERKELEY CA 94703
2	NAWC/WPNS ATTN CODE 543200E D POWELL GARY BORGEN BLDG 311 POINT MUGU CA 93042-5000	2	AEROVIRONMENT ATTN MATTHEW KEENNON ALEX ANDRIUKOV 4685-3H INDUSTRIAL ST SIMI VALLEY CA 93063
2	KDI PRECISION PRODUCTS ATTN MAX CONE WILLIAM KURTZ 3975 MCMANN ROAD CINCINATTI OH 45245-2395	1	KEVIN KORNEGAY CORNELL UNIVERSITY 413 PHILLIPS HALL ITHICA NY 14853-5401
4	APL ATTN RON DENISSEN WM DEVEREUX R BENSON H CHARLES JR 11100 JOHNS HOPKINS ROAD LAUREL MD 20723-6099	1	LUTRONIX CORP ATTN GARY LEE 13627 PORTOFINO DRIVE DEL MAR CA 92014
1	ARO ATTN THOMAS DOLIGALSKI POB 12211 RSCH TRIANGLE PK NC 27709	1	AUBURN UNIVERSITY ATTN RONALD BARRETT 211 AEROSPACE ENGINEER ST AUBURN UNIV AL 36849-5338

<u>NO. OF COPIES</u>	<u>ORGANIZATION</u>
1	OFC OF NAVAL RSCH ATTN ALLEN BOUTZ NOESS INC 800 N QUINCY ST ARLINGTON VA 22217-5660
1	PRIMEX ATTN JOSEPH BUZZETT 10101 9TH ST NORTH ST PETERSBURG FL 33716
1	ALLIANT TECHSYSTEMS ATTN MN11-1428 C CANDLAND 600 SECOND ST HOPKINS MN 55343-8384
1	NATIONS INC ATTN ROBERT CARPENTER 12249 SCIENCE DRIVE ORLANDO FL 32826
1	METACOMP TECHNOLOGIES ATTN SUKAMAR CHAKRAVARTHY 650 HAMPSHIRE ROAD WESTLAKE VILLAGE CA 91361-2501
1	BOEING ATTN ROBERT CHRISTIANSEN 3370 MIRALOMA AVE ANAHEIM CA 92803-3105
1	ANALOG DEVICES ATTN ROBERT SULOUFF 21 OSBORN STREET CAMBRIDGE MA 02139-3556
1	GERALD WINCHENBACH WL/MNAV 101 W EGLIN BLVD EGLIN AFB FL 32542-6810
1	PAUL ZEMANY LOCKHEED-SANDERS 25 CANAL ST NASHUA NH 03061-0868
	<u>ABERDEEN PROVING GROUND</u>
2	DIRECTOR US ARMY RESEARCH LABORATORY ATTN AMSRL CI LP (TECH LIB) BLDG 305 APG AA

<u>NO. OF COPIES</u>	<u>ORGANIZATION</u>
2	US ARMY ATC ATTN STEAC TC E K MCMULLEN STEAC TE H CUNNINGHAM BLDG 400
1	DIR USARL ATTN AMSRL WM B A W HORST JR BLDG 4600
15	DIR USARL ATTN AMSRL WM BA F BRANDON T BROWN L BURKE J CONDON W D'AMICO B DAVIS T HARKINS D HEPNER M HOLLIS (5 CYS) V LEITZKE A THOMPSON BLDG 4600
2	DIR USARL ATTN AMSRL WM BB H ROGERS R VON WAHLDE BLDG 1121
1	DIR USARL ATTN AMSRL WM BB T VONG BLDG 1120A
4	DIR USARL ATTN AMSRL WM BC B GUIDOS P PLOSTINS D LYONS S WILKERSON BLDG 390
1	DIR USARL ATTN AMSRL WM BD B FORCH BLDG 4600
1	DIR USARL ATTN AMSRL WB BF J LACETERA BLDG 120
1	DIR USARL ATTN AMSRL WM BR C SHOEMAKER BLDG 1121
2	DIR USARL ATTN AMSRL WM MB B BURNS L BURTON BLDG 4600

NO. OF
COPIES ORGANIZATION

ABSTRACT ONLY

1 DIRECTOR
 US ARMY RESEARCH LABORATORY
 ATTN AMSRL CS EA TP TECH PUB BR
 2800 POWDER MILL RD
 ADELPHI MD 20783-1197

INTENTIONALLY LEFT BLANK

REPORT DOCUMENTATION PAGE

Form Approved
OMB No. 0704-0188

Public reporting burden for this collection of information is estimated to average 1 hour per response, including the time for reviewing instructions, searching existing data sources, gathering and maintaining the data needed, and completing and reviewing the collection of information. Send comments regarding this burden estimate or any other aspect of this collection of information, including suggestions for reducing this burden, to Washington Headquarters Services, Directorate for Information Operations and Reports, 1215 Jefferson Davis Highway, Suite 1204, Arlington, VA 22202-4302, and to the Office of Management and Budget, Paperwork Reduction Project (0704-0188), Washington, DC 20503.

1. AGENCY USE ONLY (Leave blank)	2. REPORT DATE September 1999	3. REPORT TYPE AND DATES COVERED Final	
4. TITLE AND SUBTITLE Design and Flight Test of a Prototype Range Control Module for an 81-mm Mortar		5. FUNDING NUMBERS PR: 1L162618AH80	
6. AUTHOR(S) Hollis, M.S.L.; Brandon, F.J.; Muller, P.C. (all of ARL)		8. PERFORMING ORGANIZATION REPORT NUMBER	
7. PERFORMING ORGANIZATION NAME(S) AND ADDRESS(ES) U.S. Army Research Laboratory Weapons & Materials Research Directorate Aberdeen Proving Ground, MD 21010-5066		10. SPONSORING/MONITORING AGENCY REPORT NUMBER ARL-MR-463	
9. SPONSORING/MONITORING AGENCY NAME(S) AND ADDRESS(ES) U.S. Army Research Laboratory Weapons & Materials Research Directorate Aberdeen Proving Ground, MD 21010-5066		11. SUPPLEMENTARY NOTES	
12a. DISTRIBUTION/AVAILABILITY STATEMENT Approved for public release; distribution is unlimited.		12b. DISTRIBUTION CODE	
13. ABSTRACT (Maximum 200 words) The primary purpose of the Light Forces Program is to improve the effectiveness of fire from the infantry mortar. Advances in microelectronics, sensors, and power supplies make it possible to design and build a miniature, one-dimensional, range correction module (RCM) for the mortar. This report focuses on the flight testing of an RCM prototype device for the 81-mm mortar. The objective of testing the concept was to demonstrate the structural integrity and the drag authority of the design. Based on the experimental data, it can be seen that the un-deployed range control modules do not affect the overall drag of the projectile. It can also be seen that when the RCM deploys, it has a significant effect on range. Experimental data obtained from the test indicate that the undeployed RCM does not change the ballistic characteristics of the shell; however, when deployed, the RCM does provide a significant method of controlling range.			
14. SUBJECT TERMS flight test prototype mortar trajectory		15. NUMBER OF PAGES 30	
17. SECURITY CLASSIFICATION OF REPORT Unclassified		16. PRICE CODE	
18. SECURITY CLASSIFICATION OF THIS PAGE Unclassified	19. SECURITY CLASSIFICATION OF ABSTRACT Unclassified	20. LIMITATION OF ABSTRACT	