

ARMY RESEARCH LABORATORY



A Study of Interaction of Laser Light With Small Drops of XM46 Propellant and Related Liquids

by Kim C. Juvan and Richard A. Beyer

ARL-TR-2053

September 1999

19990929 080

Approved for public release; distribution is unlimited.

DTIC QUALITY INSPECTED 4

The findings in this report are not to be construed as an official Department of the Army position unless so designated by other authorized documents.

Citation of manufacturer's or trade names does not constitute an official endorsement or approval of the use thereof.

Destroy this report when it is no longer needed. Do not return it to the originator.

Army Research Laboratory

Aberdeen Proving Ground, MD 21005-5066

ARL-TR-2053

September 1999

A Study of Interaction of Laser Light With Small Drops of XM46 Propellant and Related Liquids

Kim C. Juvan and Richard A. Beyer
Weapons and Materials Research Directorate, ARL

Abstract

Stimulated Raman spectroscopy (SRS) has been explored as a possible diagnostic tool to determine if observable changes in composition occur in the liquid gun propellants containing hydroxyl ammonium nitrate (HAN) during irradiation by ultraviolet (UV) light. Spectra are reported for ammonium nitrate, HAN, and dilute XM46. Although signal strengths are excellent, uncontrolled variation in spectral characteristics greatly diminishes the usefulness of this technique under these conditions. No spectral evidence of UV-induced chemical change was observed.

Acknowledgments

The generous assistance of Professor Richard Chang of Yale University in providing the Bergland-Liu drop-making apparatus is gratefully acknowledged. Discussions with Nathan Klein (then of the U.S. Army Research Laboratory [ARL]) on possible photochemistry of the liquids have been important to this study.

INTENTIONALLY LEFT BLANK.

Table of Contents

	<u>Page</u>
Acknowledgments	iii
List of Figures	vii
1. Introduction	1
2. Experimental	2
3. Observations	3
3.1 Ammonium Nitrate	3
3.2 Hydroxyl Ammonium Nitrate (HAN).....	4
3.3 Liquid Propellant XM46	6
3.4 Other Studies	9
4. Summary	11
5. References	13
Appendix: The Absorption Spectrum of Nitrate Ions in Aqueous Solution	15
Distribution List	19
Report Documentation Page	21

INTENTIONALLY LEFT BLANK.

List of Figures

<u>Figure</u>		<u>Page</u>
1.	Schematic Drawing of the Optical Layout of the Experiment.....	3
2.	Five Samples of Third-Order SRS Spectra From the $1,050\text{-cm}^{-1}$ Nitrate Vibration in Ammonium Nitrate Drops Recorded Under "Fixed" Conditions.....	5
3.	Spectra From $150\text{-}\mu\text{m}$ -Diameter 6M HAN Drops Showing (a) First-Order SRS and (b, c) Examples of Second-Order SRS.....	6
4.	Comparison of the MDRs for (a) $150\text{-}\mu\text{m}$ -Diameter and (b, c) $30\text{-}\mu\text{m}$ -Diameter Drops.....	7
5.	First-Order SRS Signal From a 3M XM46 $50\text{-}\mu\text{m}$ -Diameter Drop.....	8
6.	Examples of Second-Order SRS Signal From a 3M XM46 $50\text{-}\mu\text{m}$ -Diameter Drop.....	8
7.	Four Samples of Third-Order SRS Signals From a 3M XM46 $50\text{-}\mu\text{m}$ -Diameter Drop.....	9
8.	Typical (a) First-Order Stokes SRS and (b) Third-Order Stokes SRS Signals From a $150\text{-}\mu\text{m}$ -Diameter Drop of XM46 From Drop-on-Demand Generator	10
9.	Third-Order Stokes SRS Signal From (a) 3M XM46 and (b) 6M XM46.....	10
10.	Examples of (a) First-Order and (b) Third-Order SRS Signals From 9M XM46.....	11
A-1.	Absorption Values for Nitrate and Nitrite Ions in Aqueous Solution.....	17

INTENTIONALLY LEFT BLANK.

1. Introduction

The laser ignition of liquid gun propellants based on hydroxyl ammonium nitrate (HAN) as the oxidizer has been a subject of considerable study in recent years [1-4]. Fundamental laboratory studies of the ignition of these liquids are made somewhat more difficult than comparable studies of traditional solid gun propellants because HAN-oxidized liquids do not develop complete combustion (visible flame and substantial chemical energy release) at pressures below approximately 1,200 psi (8 MPa) or greater. While they can undergo a self-propagating "fizz" reaction at atmospheric pressure, even such a process can be difficult to initiate in the short time period (hundreds of milliseconds or less) required for gun ignition. The relevance of this slow reaction to prompt ignition leading to high-pressure combustion is not direct, since the slower time-scale event may involve much different chemical pathways and be dominated by different physical processes.

An early study by Carleton et al. [5] used pressure measurements in a closed vessel to show that a small, but measurable, decomposition of the liquid was produced when a 1-J ruby laser pulse was focused near a drop of one of these propellants (LP 101). Although these experiments produced effects that were far from ignition, there were indications that the composition of the gas surrounding the drop prior to the laser "spark" was related to the amount of liquid decomposition. One possible interpretation of this observation (proposed by the present authors) is that the laser-produced plasma has a deeper ultraviolet (UV) characteristic with air (due to the carbon in carbon dioxide) than with helium gas. The explanation would be that the more active conditions correspond to plasma light that is deeper UV and, thus, more photochemically active through absorption by the nitrate groups of the propellant [6] (see the Appendix). In order to test this hypothesis and to determine if possible enhancement of laser ignition could be obtained by working with UV light, the work described in this paper was pursued.

A more sensitive probe of chemical reaction approaching ignition was sought in order to study these effects. It was decided to develop a spectroscopic technique based on single-drop resonances, apply it to these propellants, and study the effect of UV light on the observed

composition. The use of morphological-dependent resonances (MDRs) of single drops is a well-established technique [7]. This approach uses the multiple internal reflections inside small drops to provide a high-Q system for the enhancement of the resonant modes, which results in strong stimulated Raman signals, or even of laser signals when sufficient gain is present. In addition, the light path in the drop is primarily near the surface of the liquid, which might further enhance the sensitivity if UV light is strongly absorbed by the liquid. While not normally used for quantitative analysis, it was thought that the strong signal levels anticipated might provide the necessary sensitivity for the detection of a wide range of chemical species.

As discussed next, these studies were not conclusive. However, since the completion of these studies, the method has been independently proposed for application to LP XM46 ignition studies by at least two outside agencies. For this reason, it was decided that documentation of these observations was appropriate.

2. Experimental

A schematic of the experimental arrangement is shown in Figure 1. The laser light was provided by a nominal 10 ns Nd:YAG laser (Quanta-Ray DCR) with harmonic generation and separation accessories. The 532-nm second harmonic was used for stimulated Raman spectroscopy (SRS) signal generation. The second and third harmonic light (355 and 266 nm, respectively) were used as UV light sources for photochemical initiation. A limited number of observations of spontaneous Raman signals were also made with a continuous-wave argon ion laser at 514.5 nm.

Drops were produced either by a Bergland-Liu (B-L) continuous droplet generator (courtesy of Professor Richard Chang, Yale University) or a piezoelectric drop-on-demand generator constructed in-house. In both cases, appropriate electronic circuits were constructed to synchronize the laser with the drop generator. In addition, some studies were done with drops suspended on thin fibers and of liquid in capillary tubes. Light from the laser-liquid interaction was focused onto the slits of a triple spectrometer (Spex model 1877 Triplemate) and detected by

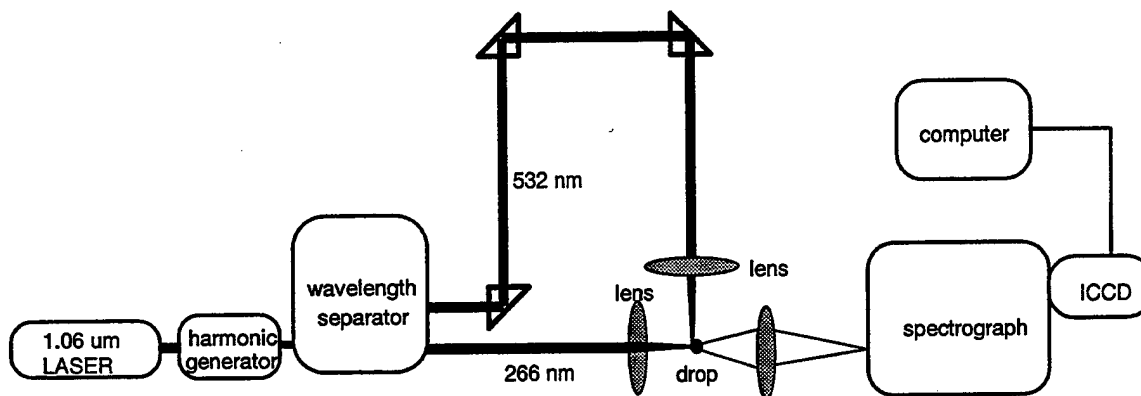

Figure 1. Schematic Drawing of the Optical Layout of the Experiment.

an intensified charge coupled device (CCD) array detector (Princeton Instruments OSMA). In order to prevent saturation of the detector, light from the drops was typically attenuated by neutral density filters with density 3.0 for first order and 1.0 for second order. The resolution of the system was about 6 cm^{-1} under typical conditions. Unless otherwise noted, all spectra shown are for a single laser pulse interacting with the liquid.

The liquid propellant known as LP 101 in Great Britain and LP 1846 and XM46 in the United States is a stoichiometric combination of HAN as the oxidizer and triethanol ammonium nitrate as the fuel. A limited amount of water is added to maintain the viscosity at useful levels. Because of the high ionic concentrations, it is more nearly a molten salt than a solution.

3. Observations

3.1 Ammonium Nitrate. Preliminary observations were made with ammonium nitrate droplets from the B-L generator. Strong scattering was observed from the first-, second-, and third-order SRS of the $1,050 \text{ cm}^{-1}$ nitrate vibration. The second-order signal is the result of subsequent Raman scattering of the first-order Raman light. Third-order SRS signals are then generated by the Raman scattering of the second-order light. The intensity of the third-order light observed attests to the high Q of the drops as resonators. Of particular note was the especially rich structure near the third-order NO_3^- and first-order H_2O bands in the region near

650 nm. Plots of typical data showing the quality of signal-to-noise ratio and variation of relative peak heights are shown in Figures 2(a)–(e). All spectra in these figures are from 1M 43- μm -diameter droplets. As seen in the figures, the resolution is good and the spectral noise is low. Under the conditions of these spectra, the UV and green beams were overlapping the nitrate droplets. The result was no change in SRS signal for a “weak” UV beam. As the UV beam energy was increased, the SRS signal finally disappeared at intensities that created dielectric breakdown (i.e., a small plasma) in the drop. The most predictable result of a photochemical reaction of a nitrate would be a nitrite. The nitrite signal (559 cm^{-1}) was characterized using potassium nitrite salt solutions. No nitrite SRS signal was detected in the nitrate either with or without the UV light. As is readily observed from the figure, the spectra varied substantially from drop to drop in terms of the appearance of MDRs and the relative heights for third-order nitrate ($1,050\text{ cm}^{-1}$) SRS and first-order water SRS. In each figure, the third-order nitrate is typically in the region from 630 to 640 nm with the water signal falling in the region from 640 to 660 nm. It had been anticipated that the water signal might somehow be used as an intensity reference, but the five spectra in Figure 2 show how subtle changes in coupling efficiency in apparently uniform stable drops are highly amplified in the resulting spectra. This observation is not totally unexpected for such a strong nonlinear technique.

3.2 Hydroxyl Ammonium Nitrate (HAN). The spectra of HAN were studied as a logical sequence of materials from ammonium nitrate to the propellant. As with the previous nitrate observations, the spectra were not stable, even for conditions where the drop generation and laser pulse energy were well behaved. A first-order and two second-order SRS spectra of 150- μm drops of HAN are shown in Figure 3. As with the ammonium nitrate, the spectra are dominated by the $1,050\text{-cm}^{-1}$ nitrate ion shift. Additional significant peaks observed include the strong peak seen in Figure 3(b), which was observed in neither the ammonium nitrate nor the complete XM46 propellant. It approximately coincides with the second-order N-OH stretching. The sharp peak on the anti-Stokes side of the nitrate peak in Figure 3(a) is possibly the first-order N-OH stretch. The two peaks close to the second-order SRS peak in Figure 3(a) were not identified.

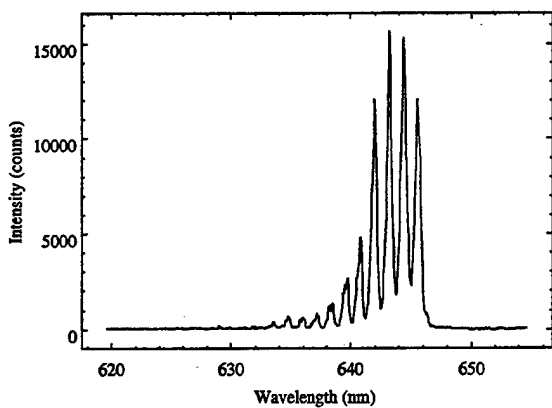

(a)

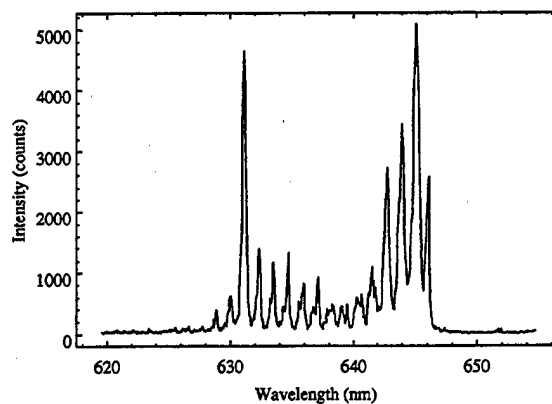

(b)

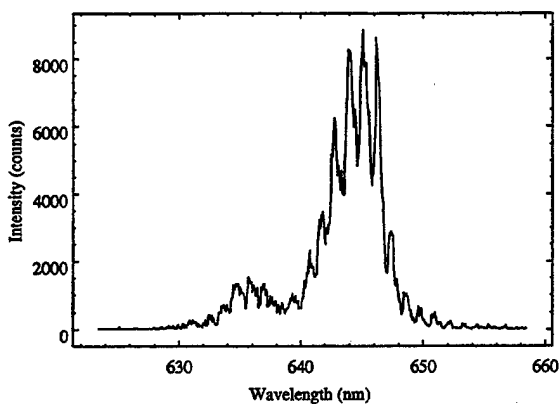

(c)

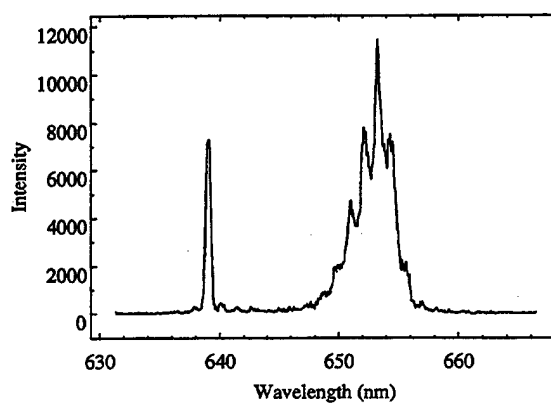

(d)

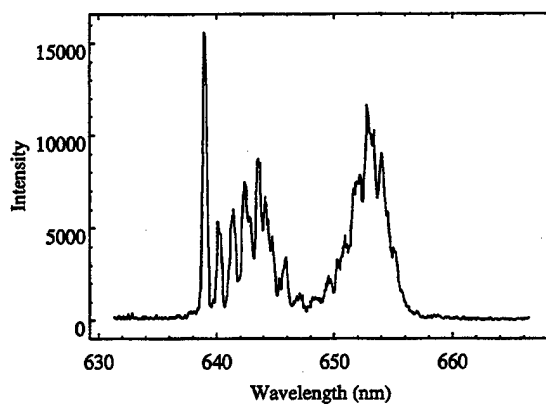

(e)

Figure 2. Five Samples of Third-Order SRS Spectra From the $1,050\text{-cm}^{-1}$ Nitrate Vibration in Ammonium Nitrate Drops Recorded Under "Fixed" Conditions.

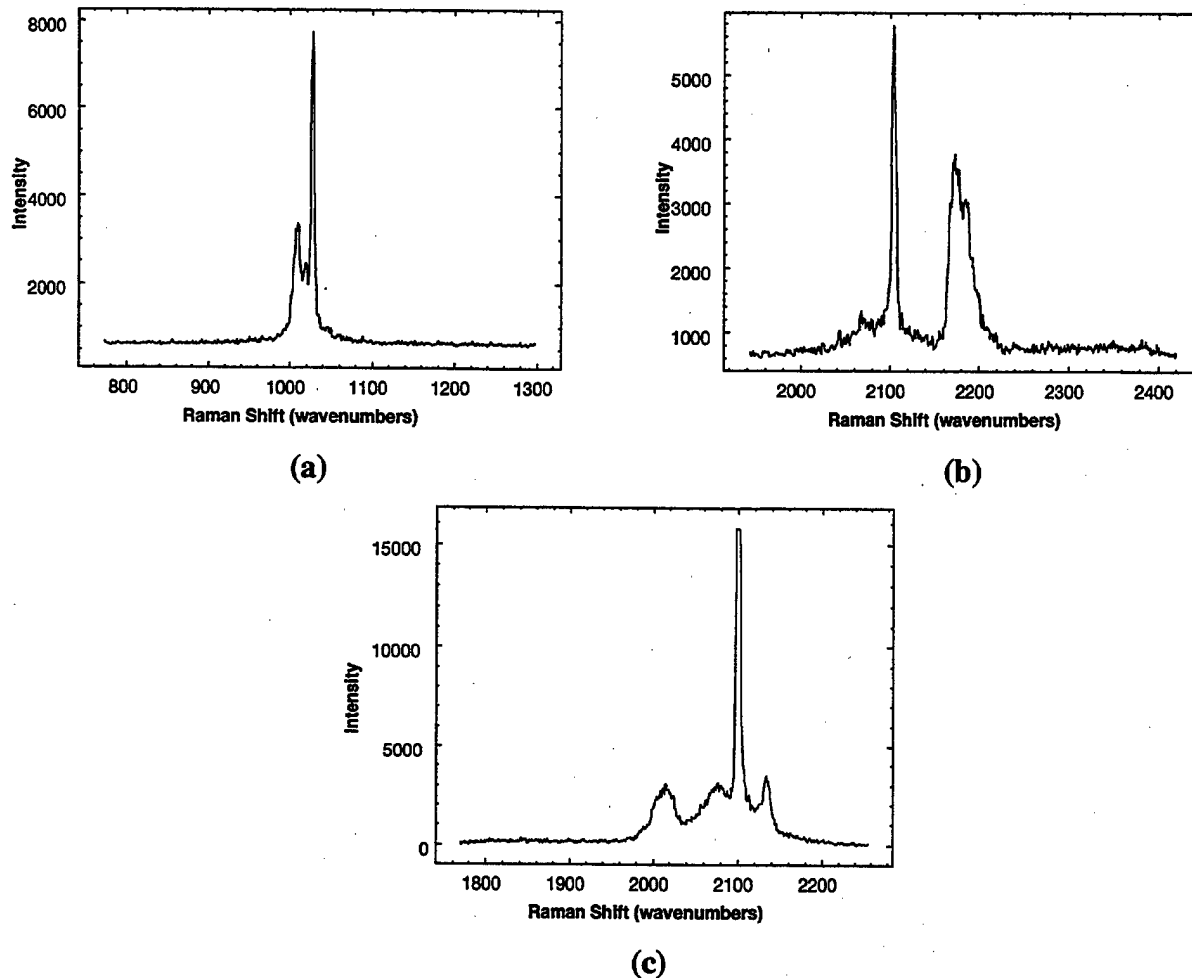

Figure 3. Spectra From 150- μ m-Diameter 6M HAN Drops Showing (a) First-Order SRS and (b, c) Examples of Second-Order SRS.

The scattering near the third-order Stokes shift in HAN exhibited the strongest structure dependence of spectra of the materials studied, other than dye solutions. In Figure 4 the spectra recorded for 150- μ m and 30- μ m diameter drops of HAN are displayed. In Figure 4(c), the sharp peaks from the third-order nitrate Stokes shift appear on a broad resonance, which has about the same intensity. The change in spacing of the sharp resonances is in qualitative agreement with the theory of MDRs for small drops.

3.3 Liquid Propellant XM46. Using the B-L drop generator, XM46 tended to clog the syringe filter fairly rapidly, resulting in unstable drop conditions. By diluting the propellant with

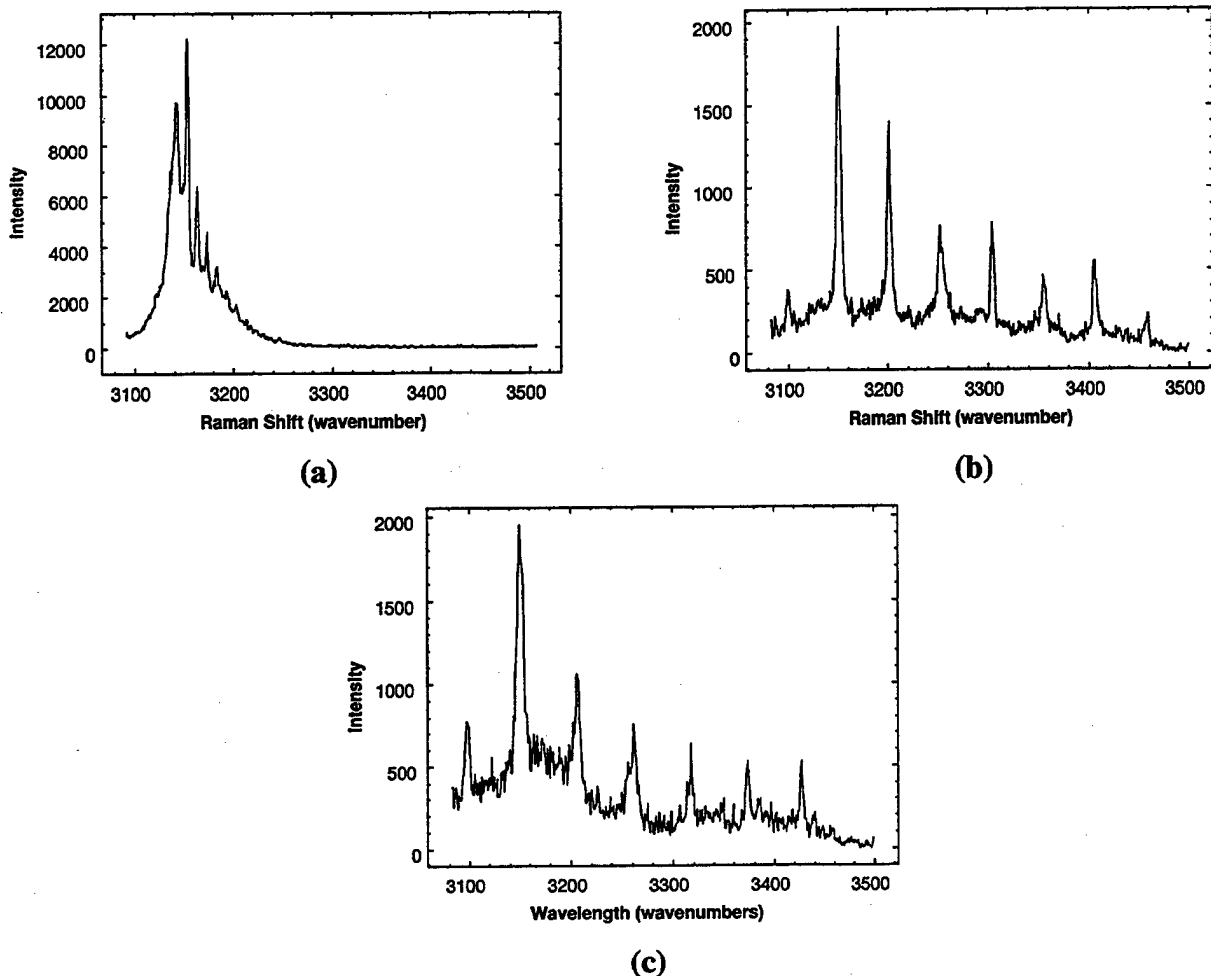

Figure 4. Comparison of the MDRs for (a) 150- μ m-Diameter Drops and (b, c) 30- μ m-Diameter Drops.

water to 3M nitrate concentration, behavior was better but still marginal. Spectra from the 50- μ m-diameter single drops are shown for three Raman orders in Figures 5–7. Figure 5 shows the first-order nitrate SRS signal. Figure 6 shows two examples of the second-order signal. Figure 7 shows four examples of the third-order signal, as well as the first-order water SRS spectrum. A UV beam incident on these drops showed no observable difference in the spectra.

In order to make observations under conditions where drops were stable over longer periods of time, the drop-on-demand generator from our laboratory was utilized with a 200- μ m orifice. With this drop source, drops stable for as long as 1 hr were obtained at a 2-Hz rate with XM46

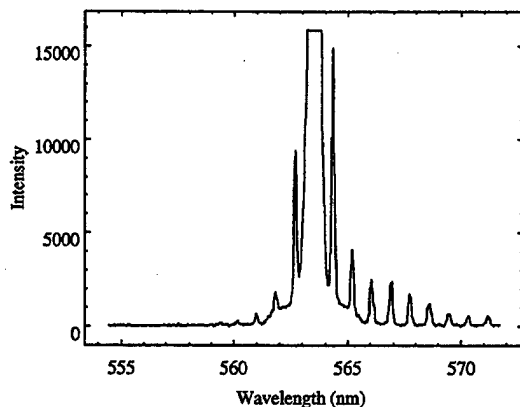

Figure 5. First-Order SRS Signal From a 3M XM46 50- μ m-Diameter Drop.

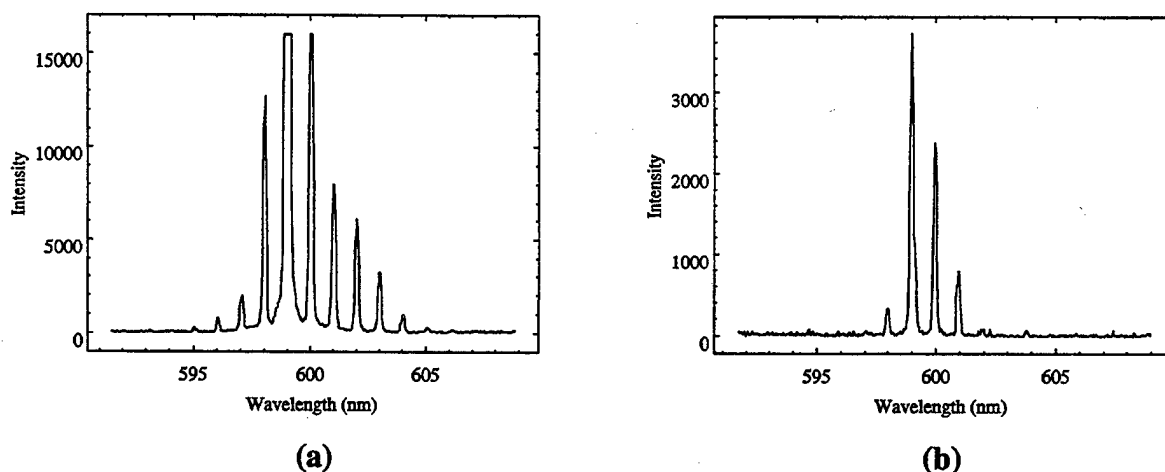

Figure 6. Examples of Second-Order SRS Signal From a 3M XM46 50- μ m-Diameter Drop.

diluted to 6M in nitrate. This setup was also used with the 3M XM46 to compare concentration effects. Typical first- and second-order SRS spectra from 150- μ m-diameter drops of 6M XM46 are shown in Figure 8. The narrow peak to the anti-Stokes side of the main peak in these spectra appears to be real. Figure 9 shows a comparison of the third-order SRS signal from the 1,050 cm^{-1} nitrate frequency for 3M and 6M nitrate concentration of XM46 for 150- μ m-diameter drops. In these spectra, a broad unidentified peak is present at the higher concentration on the Stokes side of the main peak. Although not identified, this peak shows the sensitivity of this technique for detecting changes in the vibrational structure of the liquid constituents. A limited number of spectra were recorded with 9M XM46 with nearly the same

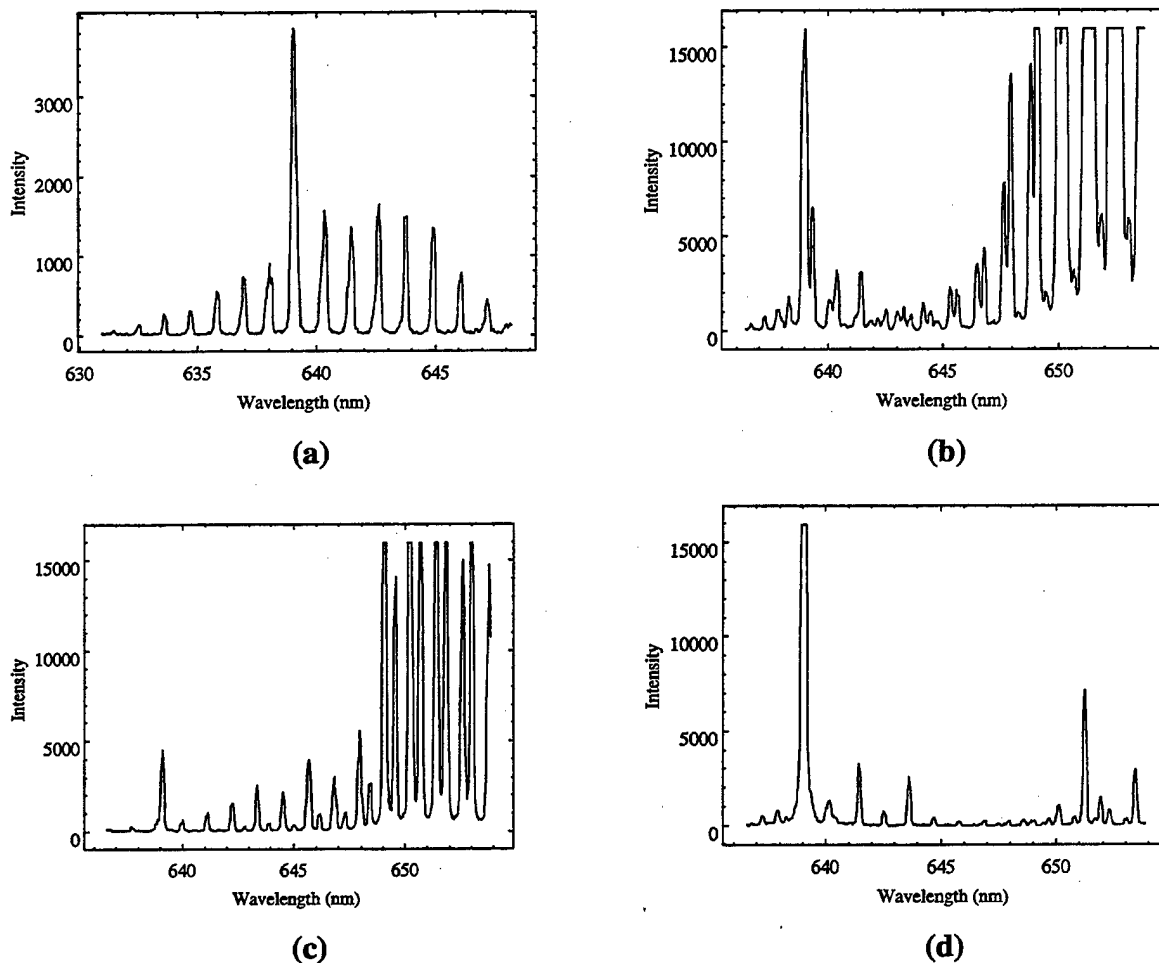

Figure 7. Four Samples of Third-Order SRS Signals From a 3M XM46 50- μ m-Diameter Drop.

conditions. Resultant first- and third-order SRS spectra are shown in Figure 10. The third-order 9M signal has some of the same characteristics of the 6M signal, especially the broad peak, and the first-order signal is suggestive of additional vibrational effects in the more concentrated liquid.

3.4 Other Studies. Additional studies were done with other geometries and with R640 rhodamine dye in water and ethanol. When 10^{-4} M R640 solution was added to 6M HAN drops, it was almost impossible to obtain even first-order SRS, except at near-breakdown intensities. For 150- μ m-diameter drops of this mixture, only broadband fluorescence was observed near

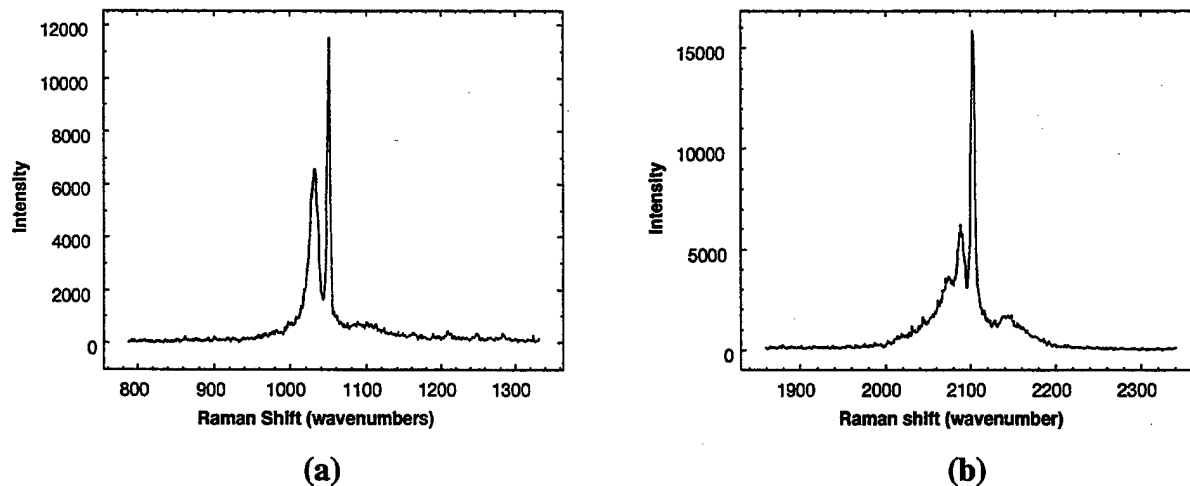

Figure 8. Typical (a) First-Order Stokes SRS and (b) Third-Order Stokes SRS Signals From a 150- μm -Diameter Drop of XM46 From Drop-on-Demand Generator.

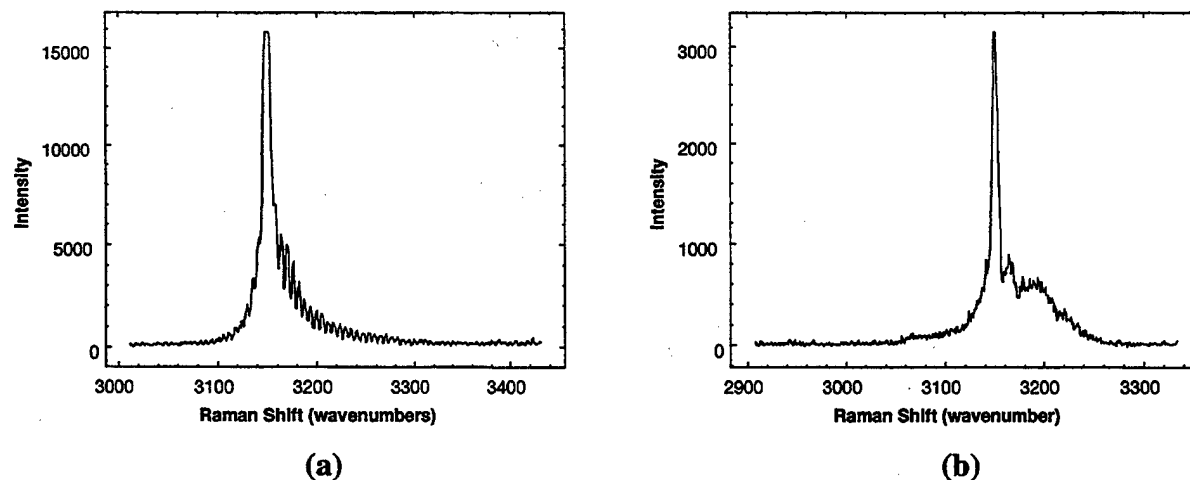

Figure 9. Third-Order Stokes SRS Signal From (a) 3M XM46 and (b) 6M XM46.

640 nm, where lasing might be expected. In contrast, the water Raman band appeared very strong and above background fluorescence.

In studies of the emission from capillary tubes filled with nitrate solution, only first-order spontaneous Raman signals were observed ($1,050\text{ cm}^{-1}$) with both the pulsed and continuous wave lasers. UV light focused on the tubes up to intensities that resulted in the melting of the edge of the tube gave no measurable change in the Raman signal. Also, no nitrite signal was

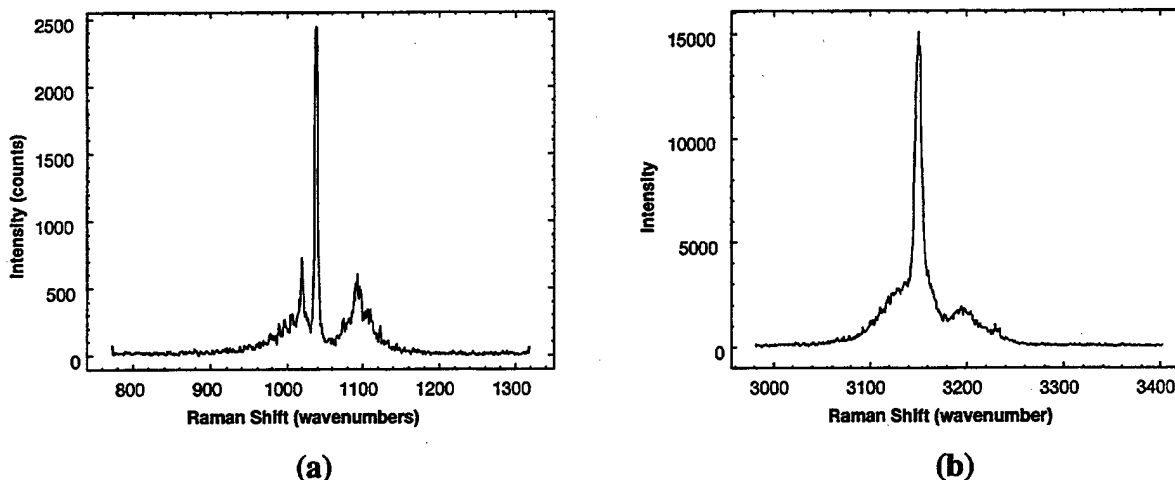

Figure 10. Examples of (a) First-Order and (b) Third-Order SRS Signals From 9M XM46.

detected. However, attempts to detect the nitrite under these conditions with 1M KNO_2 solution in the capillary tube showed that its Raman cross section was sufficiently small that any contribution from the UV light photolysis may have been lost in the background noise. Similarly, attempts were made to observe both lasing with the R640 solution and SRS generation with the nitrates from drops suspended on thin silica fibers. The cylindrical symmetry and high Raman gain observed with drops suggested that signals might be obtained in this configuration, but none were found in several attempts.

4. Summary

Stimulated Raman spectra have been generated and recorded for ammonium nitrate, HAN, and diluted LP XM46. The excellent signal-to-noise ratio that is characteristic of this technique was observed for individual spectra. However, the drop-to-drop reproducibility was very poor. This observation was made even under conditions of good laser and drop generator stability. The possible causes of this behavior remain unknown. No photochemical effects were observed from the irradiation of the drops with 355-nm and 266-nm laser light.

INTENTIONALLY LEFT BLANK.

5. References

1. Beyer, R. A., L-M. Chang, and B. E. Forch. "Laser Ignition of Propellants in Closed Chambers." ARL-TR-1055, U.S. Army Research Laboratory, Aberdeen Proving Ground, MD, 1996.
2. Beyer, R. A. "Laser Ignition of Liquid Gun Propellant XM46." ARL-TR-1058, U.S. Army Research Laboratory, Aberdeen Proving Ground, MD, 1996.
3. Beyer, R. A., J. DeSpirito, and G. P. Reeves. "Laser Ignition of Liquid Gun Propellant XM46: Transition From Small-Scale Laboratory Fixtures to Gun Igniters." ARL-TR-1056, U.S. Army Research Laboratory, Aberdeen Proving Ground, MD, 1996.
4. Beyer, R. A., and G. P. Reeves. "Laser Ignition of Liquid Propellant XM46: Ignition of Larger Volumes." ARL-TR-1292, U.S. Army Research Laboratory, Aberdeen Proving Ground, MD, 1997.
5. Carleton, F. B., N. Klein, K. Krallis, and F. J. Weinberg. *Combustion Science Technology*. Vol. 88, pp. 33-41, 1993.
6. Daniels, M., R. V. Meyers, and E. V. Belardo. *Symposium on Inorganic Photochemistry*. Vol. 72, p. 389, 1968.
7. Barber, P. W., and R. K. Chang (editors). "Optical Effects Associated With Small Particles." Singapore: World Scientific, 1988.

INTENTIONALLY LEFT BLANK.

Appendix:

**The Absorption Spectrum of Nitrate Ions
in Aqueous Solution**

INTENTIONALLY LEFT BLANK.

The possible photochemical effects of ultraviolet (UV) light on the propellant XM46 depend on the absorption of this light by the liquid. Because of the lack of a readily available absorption curve for nitrate ions, which dominate the absorption by the LP, a plot of the absorption curves of nitrate and nitrite ions is presented in Figure A-1. These data are courtesy of Dr. Nathan Klein of the U.S. Army Research Laboratory (ARL). As can be seen, the absorption at 266 nm is relatively low, although, experimentally, it appeared to be sufficient to absorb the laser light in a short distance. Much stronger absorption could be obtained by the use of excimer light at 193 nm and 248 nm.

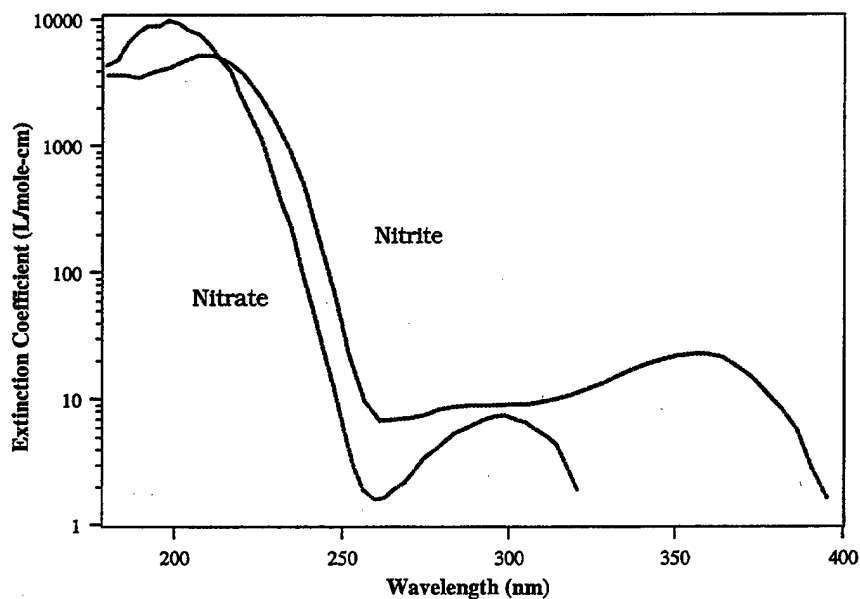

Figure A-1. Absorption Values for Nitrate and Nitrite Ions in Aqueous Solution.

INTENTIONALLY LEFT BLANK.

NO. OF
COPIES ORGANIZATION

- 2 DEFENSE TECHNICAL
INFORMATION CENTER
DTIC DDA
8725 JOHN J KINGMAN RD
STE 0944
FT BELVOIR VA 22060-6218
- 1 HQDA
DAMO FDQ
D SCHMIDT
400 ARMY PENTAGON
WASHINGTON DC 20310-0460
- 1 OSD
OUSD(A&T)/ODDDR&E(R)
R J TREW
THE PENTAGON
WASHINGTON DC 20301-7100
- 1 DPTY CG FOR RDA
US ARMY MATERIEL CMD
AMCRDA
5001 EISENHOWER AVE
ALEXANDRIA VA 22333-0001
- 1 INST FOR ADVNCD TCHNLGY
THE UNIV OF TEXAS AT AUSTIN
PO BOX 202797
AUSTIN TX 78720-2797
- 1 DARPA
B KASPAR
3701 N FAIRFAX DR
ARLINGTON VA 22203-1714
- 1 NAVAL SURFACE WARFARE CTR
CODE B07 J PENNELLA
17320 DAHLGREN RD
BLDG 1470 RM 1101
DAHLGREN VA 22448-5100
- 1 US MILITARY ACADEMY
MATH SCI CTR OF EXCELLENCE
DEPT OF MATHEMATICAL SCI
MADN MATH
THAYER HALL
WEST POINT NY 10996-1786

NO. OF
COPIES ORGANIZATION

- 1 DIRECTOR
US ARMY RESEARCH LAB
AMSRL DD
J J ROCCHIO
2800 POWDER MILL RD
ADELPHI MD 20783-1197
- 1 DIRECTOR
US ARMY RESEARCH LAB
AMSRL CS AS (RECORDS MGMT)
2800 POWDER MILL RD
ADELPHI MD 20783-1145
- 3 DIRECTOR
US ARMY RESEARCH LAB
AMSRL CI LL
2800 POWDER MILL RD
ADELPHI MD 20783-1145
- ABERDEEN PROVING GROUND
- 4 DIR USARL
AMSRL CI LP (BLDG 305)

NO. OF
COPIES ORGANIZATION

ABERDEEN PROVING GROUND

7 DIR USARL
AMSRL WM BD
G CHABALOWSKI
R PESCE-RODRIGUEZ
R BEYER (3 CPS)
J VANDERHOFF
B FORCH

REPORT DOCUMENTATION PAGE			Form Approved OMB No. 0704-0188	
Public reporting burden for this collection of information is estimated to average 1 hour per response, including the time for reviewing instructions, searching existing data sources, gathering and maintaining the data needed, and completing and reviewing the collection of information. Send comments regarding this burden estimate or any other aspect of this collection of information, including suggestions for reducing this burden, to Washington Headquarters Services, Directorate for Information Operations and Reports, 1215 Jefferson Davis Highway, Suite 1204, Arlington, VA 22202-4302, and to the Office of Management and Budget, Paperwork Reduction Project (0704-0188), Washington, DC 20503.				
1. AGENCY USE ONLY (Leave blank)		2. REPORT DATE	3. REPORT TYPE AND DATES COVERED	
		September 1999	Final, Feb-Jun 92	
4. TITLE AND SUBTITLE			5. FUNDING NUMBERS	
A Study of Interaction of Laser Light With Small Drops of XM46 Propellant and Related Liquids			1L161102AH43	
6. AUTHOR(S)				
Kim C. Juvan and Richard A. Beyer				
7. PERFORMING ORGANIZATION NAME(S) AND ADDRESS(ES)			8. PERFORMING ORGANIZATION REPORT NUMBER	
U.S. Army Research Laboratory ATTN: AMSRL-WM-BD Aberdeen Proving Ground, MD 21005-5066			ARL-TR-2053	
9. SPONSORING/MONITORING AGENCY NAMES(S) AND ADDRESS(ES)			10. SPONSORING/MONITORING AGENCY REPORT NUMBER	
11. SUPPLEMENTARY NOTES				
12a. DISTRIBUTION/AVAILABILITY STATEMENT			12b. DISTRIBUTION CODE	
Approved for public release; distribution is unlimited.				
13. ABSTRACT (Maximum 200 words)				
<p>Stimulated Raman spectroscopy (SRS) has been explored as a possible diagnostic tool to determine if observable changes in composition occur in the liquid gun propellants containing hydroxyl ammonium nitrate (HAN) during irradiation by ultraviolet (UV) light. Spectra are reported for ammonium nitrate, HAN, and dilute XM46. Although signal strengths are excellent, uncontrolled variation in spectral characteristics greatly diminishes the usefulness of this technique under these conditions. No spectral evidence of UV-induced chemical change was observed.</p>				
14. SUBJECT TERMS			15. NUMBER OF PAGES	
XM46, Raman spectroscopy, liquid propellant			22	
			16. PRICE CODE	
17. SECURITY CLASSIFICATION OF REPORT	18. SECURITY CLASSIFICATION OF THIS PAGE	19. SECURITY CLASSIFICATION OF ABSTRACT	20. LIMITATION OF ABSTRACT	
UNCLASSIFIED	UNCLASSIFIED	UNCLASSIFIED	UL	

INTENTIONALLY LEFT BLANK.

USER EVALUATION SHEET/CHANGE OF ADDRESS

This Laboratory undertakes a continuing effort to improve the quality of the reports it publishes. Your comments/answers to the items/questions below will aid us in our efforts.

- 1. ARL Report Number/Author ARL-TR-2053 (Juvan [Beyer]) Date of Report September 1999
- 2. Date Report Received _____
- 3. Does this report satisfy a need? (Comment on purpose, related project, or other area of interest for which the report will be used.) _____

- 4. Specifically, how is the report being used? (Information source, design data, procedure, source of ideas, etc.) _____

- 5. Has the information in this report led to any quantitative savings as far as man-hours or dollars saved, operating costs avoided, or efficiencies achieved, etc? If so, please elaborate. _____

- 6. General Comments. What do you think should be changed to improve future reports? (Indicate changes to organization, technical content, format, etc.) _____

CURRENT ADDRESS	_____	Organization	
	_____	Name	E-mail Name
	_____	Street or P.O. Box No.	
	_____	City, State, Zip Code	

7. If indicating a Change of Address or Address Correction, please provide the Current or Correct address above and the Old or Incorrect address below.

OLD ADDRESS	_____	Organization
	_____	Name
	_____	Street or P.O. Box No.
	_____	City, State, Zip Code

(Remove this sheet, fold as indicated, tape closed, and mail.)
(DO NOT STAPLE)