



A Dihedral Sample Mount for Off-Normal RAM Performance Measurements

by Robert B. Bossoli

ARL-TR-2049

September 1999

19991001 047

Approved for public release; distribution is unlimited.

The findings in this report are not to be construed as an official Department of the Army position unless so designated by other authorized documents.

Citation of manufacturer's or trade names does not constitute an official endorsement or approval of the use thereof.

Destroy this report when it is no longer needed. Do not return it to the originator.

Army Research Laboratory

Aberdeen Proving Ground, MD 21005-5069

ARL-TR-2049

September 1999

A Dihedral Sample Mount for Off-Normal RAM Performance Measurements

Robert B. Bossoli

Weapons and Materials Research Directorate, ARL

Abstract

A novel sample mount has been designed for making high angle of incidence radar-absorbing material (RAM) sample performance measurements. The sample mount allows for $\sim 47^\circ$ angle of incidence measurement of RAM millimeter-wave (MMW) reflectivity (performance). Measurements are taken from 26–60 GHz and 75–100 GHz in the U.S. Army Research Laboratory's (ARL) Weapons and Materials Research Directorate (WMRD) Composites and Lightweight Structures Branch (CLSB) anechoic chamber. RAM samples can also be mounted in a full dihedral configuration for simulation of RAM performance in double bounce (corner)-type locations. Performance of two commercial-type RAM materials was measured at close to normal and at the $\sim 47^\circ$ off-normal angles of incidence. A full dihedral covered with one of the commercial RAMs was also tested. The mount will allow for more realistic evaluation of ARL- and contractor-designed RAM and other coatings to be utilized in low-observable Army and Department of Defense (DOD) projects.

Acknowledgments

The author offers thanks to technicians Frederick B. Pierce and Joseph J. Correr, Jr., for their assistance with the machining and assembly of the dihedral mount. The author would also like to thank Michael R. McNeir and Steven G. Cornelison for offering corrections and helpful suggestions in their review of this report.

INTENTIONALLY LEFT BLANK.

Table of Contents

	<u>Page</u>
Acknowledgments	iii
List of Figures	vii
1. Introduction	1
2. RAM Reflectivity Test Setup	1
2.1 Standard RAM Performance Measurement System.....	1
2.2 Dihedral RAM Performance Mount Design	4
2.3 RAM Measurement Procedure Using Dihedral Sample Mount.....	4
3. Experiment Results for Commercial RAM	7
3.1 Performance Results on a Standard Mount With a 10° Bistatic Angle.....	8
3.2 RAM Performance Results for Off-Normal (47°) Incidence	10
4. Conclusions	14
Distribution List	15
Report Documentation Page	23

INTENTIONALLY LEFT BLANK.

List of Figures

<u>Figure</u>		<u>Page</u>
1.	Bistatic RAM Sample Performance Measurement Configuration	2
2.	System Configuration Diagrams for (a) Microwave and (b) MMW RAM Sample Performance Measurements	3
3.	Photos of the Standard RAM Sample Mount (Left) and the MMW Bistatic Measurement System (Right)	4
4.	Photo of the Dihedral RAM Performance Sample Mount	5
5.	Top View of Path of Radar Wave for (a) Standard and (b) Dihedral RAM Sample Mounts.....	6
6.	Reflectivity From 26.5–100 GHz for AAP ML-73 at 5° (Normal) Angle of Incidence	9
7.	Reflectivity From 26.5–100 GHz for Black Net Sample at 5° (Normal) Angle of Incidence	11
8.	Reflectivity From 26.5–100 GHz for AAP ML-73 RAM at 47° (Off Normal) Angle of Incidence	12
9.	Reflectivity From 26.5–100 GHz for Black Net RAM at 47° (Off Normal) Angle of Incidence	13
10.	Reflectivity From 26.5–100 GHz for AAP ML-73 RAM Covered Dihedral at 47° (Off Normal) Angle of Incidence.....	14

INTENTIONALLY LEFT BLANK.

1. Introduction

Numerous types of radar-absorbing materials (RAM) have been developed over the past 50 yr in response to try to defeat radar deployed on the battlefield and on naval vessels. Only recently, however (past 10 yr), has the technology developed to the point where it can be effectively incorporated into military systems. The stealth fighters (F-111 and F-22 Raptor) and the stealth bomber (B-2) are two well-known examples of military systems where RAM technology has been incorporated into their design. The development of smaller millimeter-wave (MMW) components with the required power output has led to their incorporation into battlefield surveillance and tracking radar and into smart munitions. This new, higher frequency band radar can offer a variety of threats, ranging from detection to destruction of currently fielded Army vehicles and structures. RAM and radar-absorbing coatings (RACOs) are designed to reduce the radar reflection over various important (threat) bands of radar frequencies. Their performance is tested for normal (90°) or close to normal angles of incidence of the radar beam with respect to the RAM surface. For systems with complex angles and shapes, such as on ships, trucks, and other vehicles, radar returns are usually a result of double or triple bounce (reflections) back to the transmitting radar. A sample mount simulating the two-surface double bounce (dihedral configuration) has been designed and built for the microwave measurement range of the U.S. Army Research Laboratory's (ARL) Weapons and Materials Research Directorate (WMRD) Composites and Lightweight Structures Branch (CLSB) Materials Physics Team. This paper describes the mount and the measurement procedure, along with some experimental performance results for commercially available microwave-absorbing materials. Dihedral performance data for the team's SECRET/SAP materials under development by the group will be presented in a separate future report.

2. RAM Reflectivity Test Setup

2.1 Standard RAM Performance Measurement System. Figure 1 shows a diagram of the standard ARL-RAM performance measurement setup, where the angle of incidence is almost normal to the sample with the radar horns in a bistatic ($\sim 10^\circ$) configuration. Sample sizes are

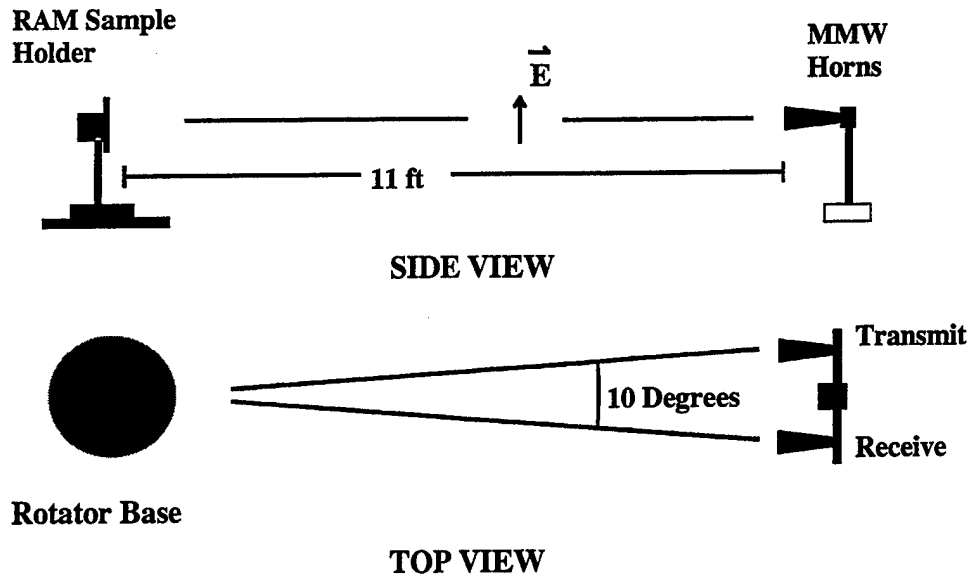
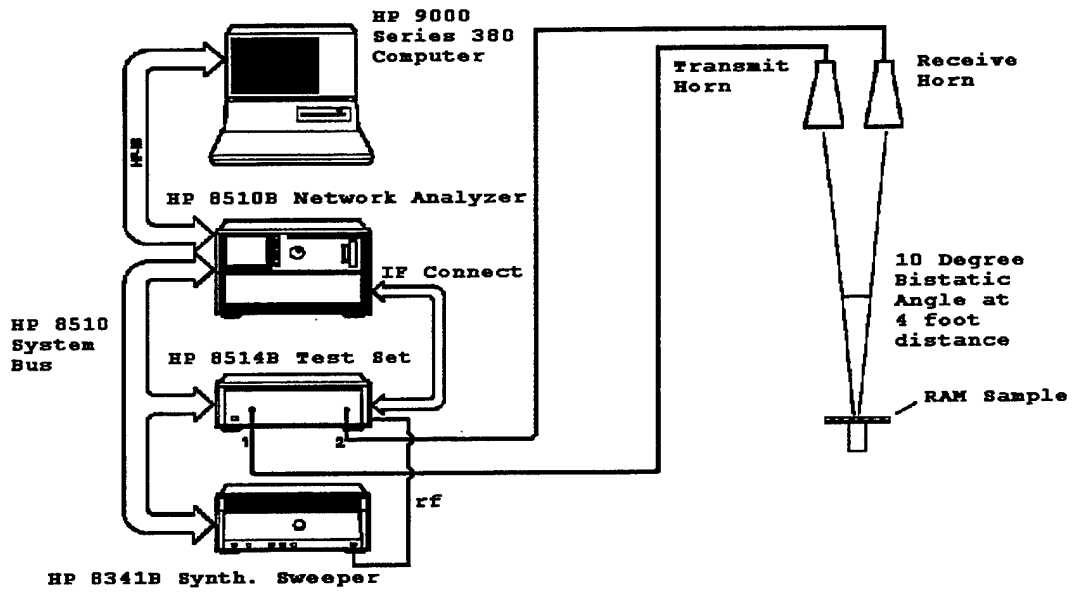

Figure 1. Bistatic RAM Sample Performance Measurement Configuration.

usually 6×6 in or 12×12 in, and the radar performance is referenced to a metal plate of the same dimensions. The Materials Physics Team RACO measurement system employs a Hewlett Packard (HP) 8510B microwave network analyzer with sweepers and MMW modules, allowing RAM and RACO performance measurements in the 2–20-, 26–40-, 40–60-, and 75–100-GHz frequency bands. Block diagrams of the microwave and MMW equipment configurations are shown in Figures 2(a) and (b), respectively. The system uses linearly polarized microwave or MMW transmit and receive horns with a $\pm 10^\circ$ bistatic angle (5° angle of incidence). The low-frequency (2–20 GHz) horns are configured in an arch-type configuration, allowing the bistatic angle to be changed by 10° increments from 10 – 50° . A single horn can be employed to transmit and receive in the low-frequency band, performing true normal (0° angle of incidence) reflectivity measurements if required.

Figure 3 shows a photo of the standard (single bounce) sample mount, along with a photo of the bistatic MMW horns and HP network analyzer covering the high-frequency 26–40-, 40–60-, and 75–100-GHz frequency bands. The RAM samples are mounted on 6×6 -in metal backing plates and replace the reference metal plate, as seen in the left-hand photo in Figure 3. They are held in place by a double-stick tape and a lip on the bottom edge of the mount.



(a)

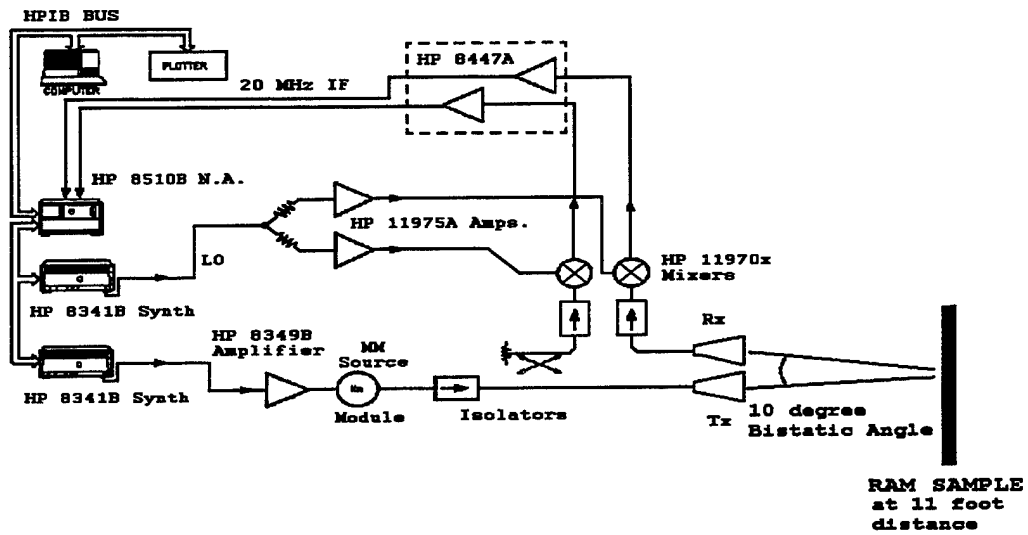

(b)

Figure 2. System Configuration Diagrams for (a) Microwave and (b) MMW RAM Sample Performance Measurements.

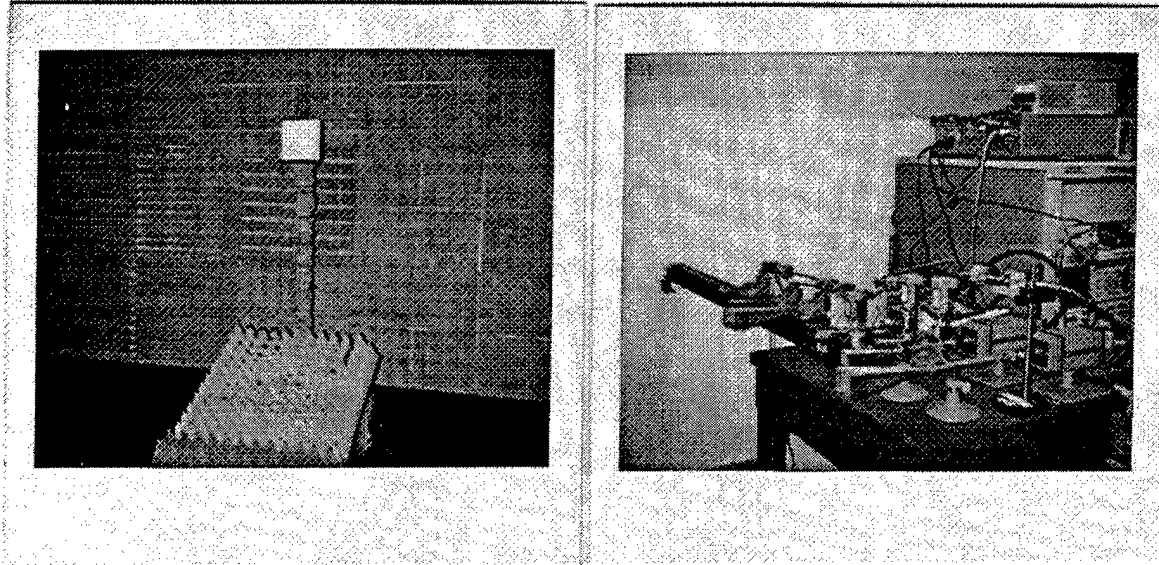

Figure 3. Photos of the Standard RAM Sample Mount (Left) and the MMW Bistatic Measurement System (Right).

2.2 Dihedral RAM Performance Mount Design. Figure 4 shows a close-up photo of the dihedral sample mount that replaces the standard single-bounce “normal incidence” sample mount (shown in Figure 3) for high-frequency (26–40, 40–60, and 75–100 GHz) MMW measurements. The mount consists of two 6- \times 6-in plate holders joined at one edge, with the angle between them at approximately 90°. One of the plate holders is adjustable in angle, so the angle between the two holders is variable from about 80–110°. For a monostatic radar, the maximum return for a double-bounce (dihedral) configuration is for the plates oriented at a 90° angle [see Figure 5(a)]. However, as shown in the diagram in Figure 5(b) for a 10° bistatic configuration, the optimum angle for double-bounce returns for the plates on the “dihedral” mount is 95°. The dihedral measurement sample fixture is attached to a azimuthal rotator on the floor via a 4-ft pipe, which enables the alignment for the a symmetric double bounce back to the radar horns, as depicted in Figure 5(b).

2.3 RAM Measurement Procedure Using Dihedral Sample Mount. In order to measure a sample or pair of samples of the same design in the of angle dihedral configuration, the mount

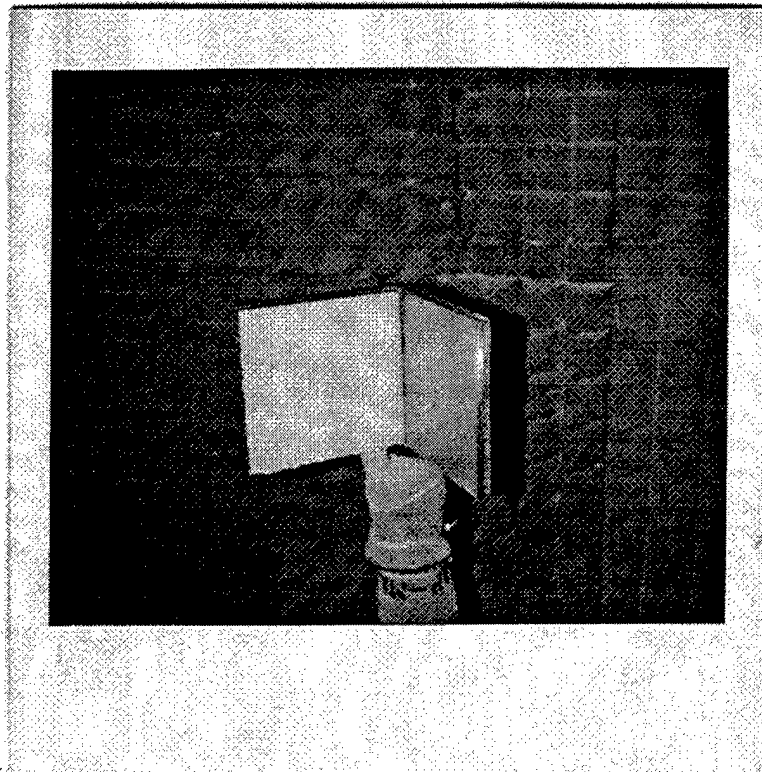
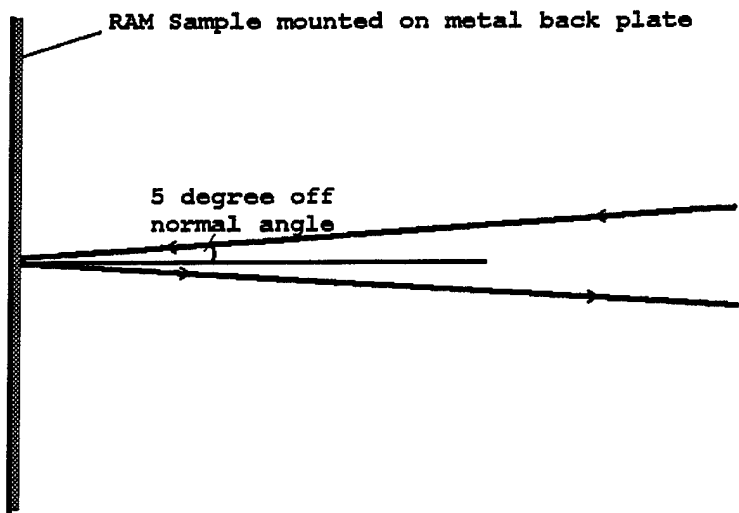

Figure 4. Photo of the Dihedral RAM Performance Sample Mount.

must be aligned (rotated) to give proper orientation as detailed previously. With two 6- × 6-in bare aluminum sample plates placed in the dihedral sample mount, it is rotated so that one of the plates is oriented for maximum reflection at near-normal incidence [as in Figure 5(a) for the 10° bistatic angle of the radar horns] and the rotator is reset to read 0°. Since the angle between the dihedral is 95°, the rotator must be rotated $(180-95)/2^\circ$, or about 42.5°, to correctly orient the dihedral mount [as depicted in Figure 5(b)] for making the off-normal-incidence measurements. When the frequency is switched to another frequency band with different pair of transmit/receive horns, this alignment procedure must be repeated.

After the dihedral mount is aligned, the microwave network analyzer (NWA) is programmed to take a reference set of data with two bare metal reference plates in position on the mount. These data are stored into the NWA memory, and utilizing the divide-by memory function will be the reference data to which the subsequent measured data are compared. For the large



TOP VIEW OF NEAR NORMAL RADAR REFLECTION
FOR 10 DEGREE BISTATIC PERFORMANCE MEASUREMENTS

(a)

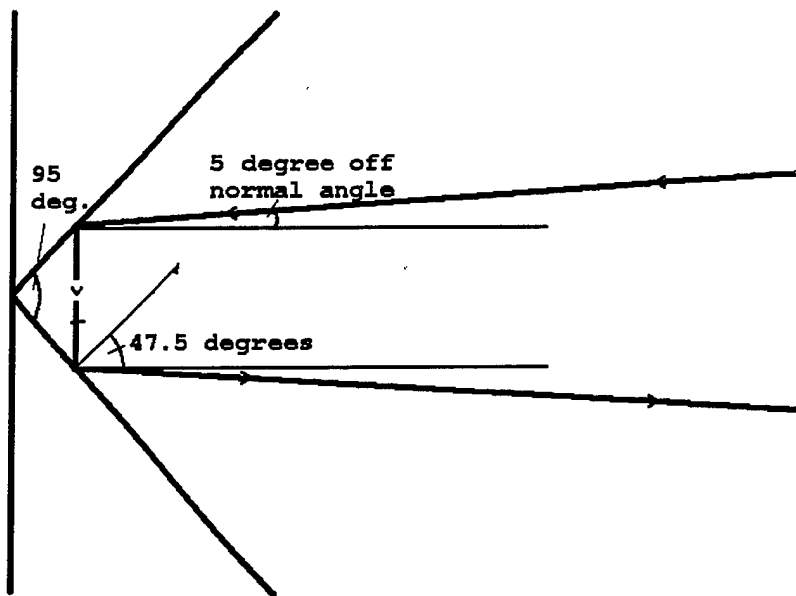

TOP VIEW OF 95 DEGREE DIHEDRAL RADAR BOUNCE CONFIGURATION
FOR 10 DEGREE BISTATIC RADAR MEASUREMENTS

(b)

Figure 5. Top View of Path of Radar Wave for (a) Standard and (b) Dihedral RAM Sample Mounts.

off-angle ($\sim 47^\circ$ incidence), RAM performance measurements, the sample (mounted on a 6- x 6-in metal sample plate) is put in place of one of the bare metal sample plates. When the data are taken (division by the reference data) in log format, the performance of the RAM at the $\sim 47^\circ$ angle of incidence is measured. Since, in this configuration, the edges of the plates are facing toward the microwave horns, small strips of commercial RAM (Advanced Absorber Products [AAP]-type ML-73) are sometimes placed on the plate edge facing the transmit horn to help reduce scattering back to the receiver horn. However, in general, there is much more noise and interference effects in the data due to the orientation and scattering off of the edges of the plates in the dihedral measure configuration, as compared to the normal-incidence data. For a test of a double-bounce performance of a type of RAM material, two samples mounted on 6- x 6-in metal plates, or mounted on the dihedral holder and the reflection measurement performed, again referenced the bare-plate dihedral data. In this case, the results mimic what a RAM-coated corner reflector would reflect back to a radar or what a double bounce off two RAM-covered surfaces orientated at $\sim 45^\circ$ would attenuate the incident radar signal.

3. Experiment Results for Commercial RAM

The performance (reflection coefficient) of two different types of commercial RAM samples was measured. The first type is a black-colored net or mesh-like material approximately 3/4 in thick, made by General Atomics. It has a copper-coated, highly conductive portion (bottom 1/8 in), which acts as a ground plane preventing any radar penetration. The fact that the material is mostly air and is a thick netting with a mesh-like construction makes it highly probable that it will scatter a substantial portion of the incident radar signal in all directions, as well as absorbing the signal. The net will have low reflection off the front surface since it is irregular, and radar waves will be absorbed and/or scattered by it, depending on the resistivity of the net material or its surface coating. This enables it to be an effective absorber/scatterer over a wide-frequency range. The drawbacks of this design are that it will probably be much less effective in an outdoor environment due to moisture/water penetration.

The second type of commercial RAM sample is a carbon-loaded, lightweight, multilayer foam material manufactured (type ML-73) by AAP. It has a total thickness of 1.1 cm, with each layer (probably with different carbon loading) having a thickness of about 3.5 mm. This material utilizes the resistivity of the carbon particles to absorb a portion of the radar signal. Since it has a fairly flat front surface, the material will probably exhibit some broad absorption peaks where it has some destructive interference occurring between radar waves reflected off the front surface and those making it through the material after reflecting off the backing plate. The material has a blue spray paint outer layer to help prevent mechanical deterioration during handling. This material, again, is not very effective outdoors in a wet environment since the light carbon-loaded foam material is not very durable and would also absorb water, affecting its radar-absorbing ability. The material is flexible, can be wrapped around objects and mounts to prevent radar returns, and is mainly utilized indoors in anechoic chambers designed for radar and antenna tests.

3.1 Performance Results on a Standard Mount With a 10° Bistatic Angle.

Measurements were first made on the two commercial absorbers with the standard RAM sample mount at close-to-normal incidence (5°). The performance measurements from 26.5 to 100 GHz for the AAP absorber sample are shown in Figure 6. The parallel data refer to the orientation of the microwave E-field vector with respect to one chosen side of the square 6- × 6-in sample. The perpendicular data refer to the sample rotated 90° and replaced on the mount so the microwave E-field is perpendicular to the chosen side of the sample. Due to the design and composition of the two commercial RAM samples, they should not exhibit any anisotropy in their performance for each orientation with respect to the microwave electric field (E-field) vector polarization. The parallel and perpendicular data (Figure 6) for the AAP sample exhibit essentially the same reflection coefficient.

Figure 7 displays the parallel and perpendicular MMW reflectivity data for the black-net sample. The combined absorbing and scattering character of the netting makes it an effective

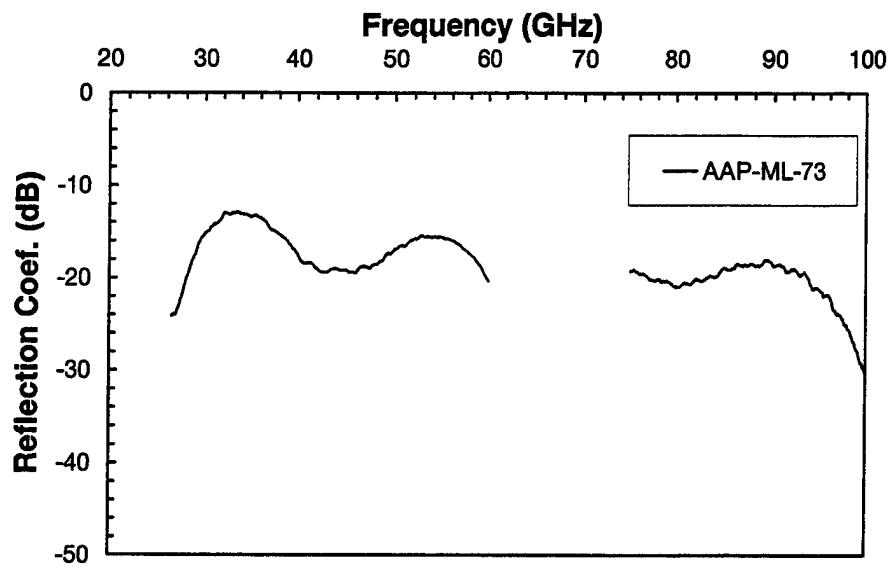

(a) Parallel

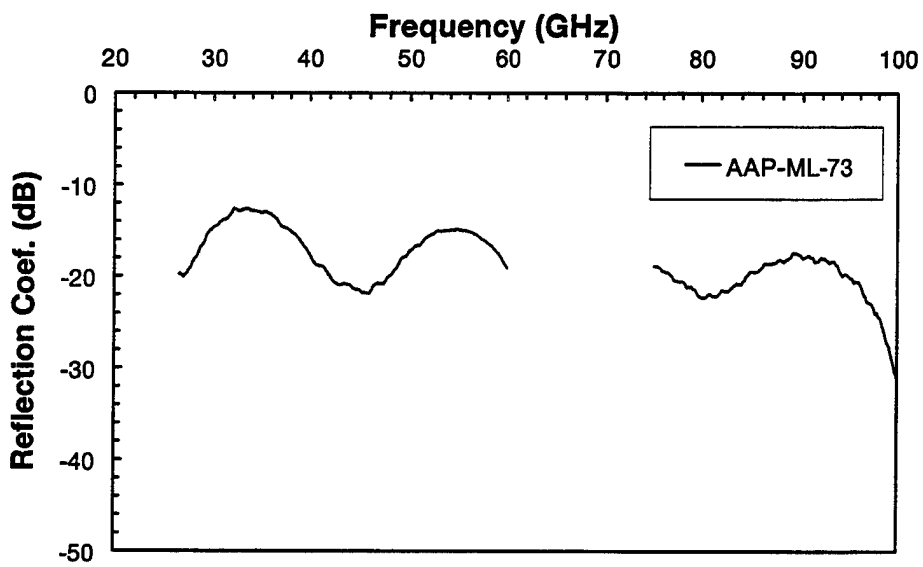

(b) Perpendicular

Figure 6. Reflectivity From 26.5–100 GHz for AAP ML-73 at 5° (Normal) Angle of Incidence.

radar-camouflage material, as its reflection coefficient is better than -30 dB over the entire frequency range.

3.2 RAM Performance Results for Off-Normal (47°) Incidence. Figure 8 shows the reflection coefficient results for the AAP absorber sample when placed on one side of the dihedral sample mount. This results in an approximately 47° angle of incidence for the microwaves illuminating the sample, which, after exiting the sample, are reflected back to the receiving horn by the metal plate forming the second part of the dihedral [see Figure 5(b)]. The parallel and perpendicular reflection coefficient data are, again, similar, with an average absorption of more than -11 dB and absorption peaks at 35 (greater than -25 dB) and 86 GHz (greater than 21 dB), with respect to a metal plate in this configuration. Overall, the performance of this absorber is worse at this off angle, except at the frequencies noted.

The 47° angle of incidence reflection coefficient data for the black-net sample are displayed in Figure 9. The increased number of maxima and minima in the data are the results of interference effects due to multiple plate edges and joints present in the dihedral sample configuration. The average performance of the black net is about the same over the frequency range for both parallel and perpendicular orientations (better than 30 dB), with respect to a metal plate. This result would be expected for a thicker "net-type absorber," which works due to scattering and some absorption of the incident microwaves along the longer path through which the signal traverses through the material at the increased angle of incidence (~47°).

One other configuration was measured with the dihedral mount. Two 6- × 6-in samples of the AAP absorber with metal backing plates were mounted on each side of the dihedral. Figure 10 shows the performance data for the AAP dihedral. In this case, although the AAP absorber does not perform as well "off normal," the microwaves must pass through the material twice to be reflected back to the receive horn. The performance is better than -20 dB across the measured frequency range, with -40 dB or more absorption with respect the metal plates at the two peaks occurring at 35 and 86 GHz.

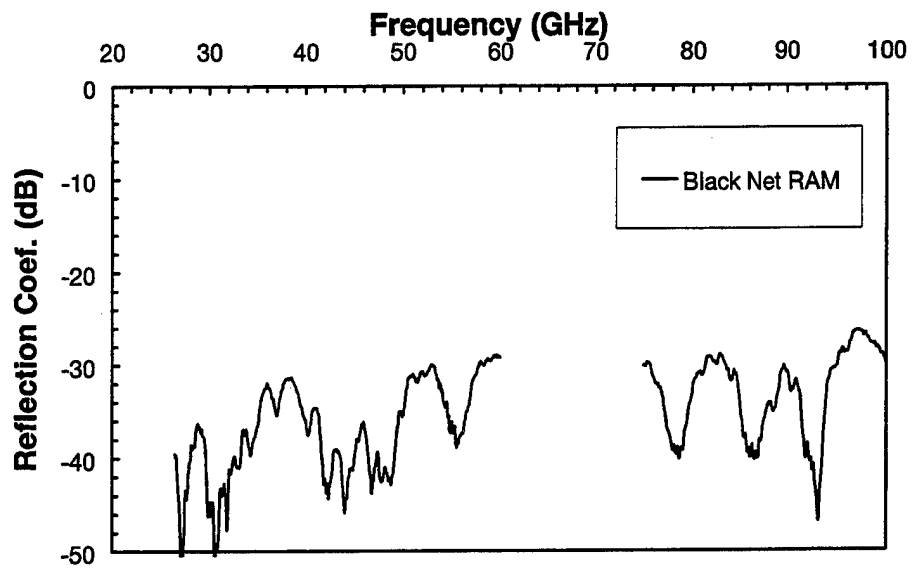

(a) Parallel

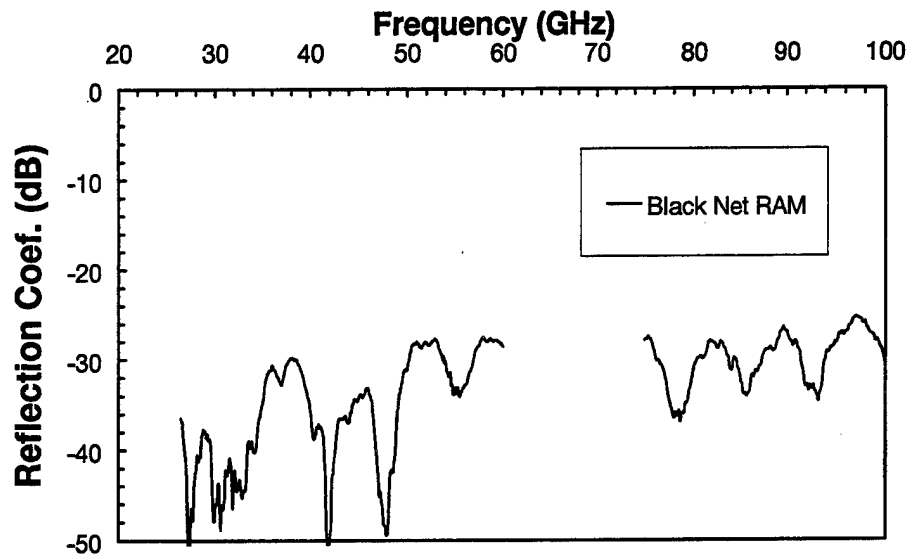

(b) Perpendicular

Figure 7. Reflectivity From 26.5–100 GHz for Black Net Sample at 5° (Normal) Angle of Incidence.

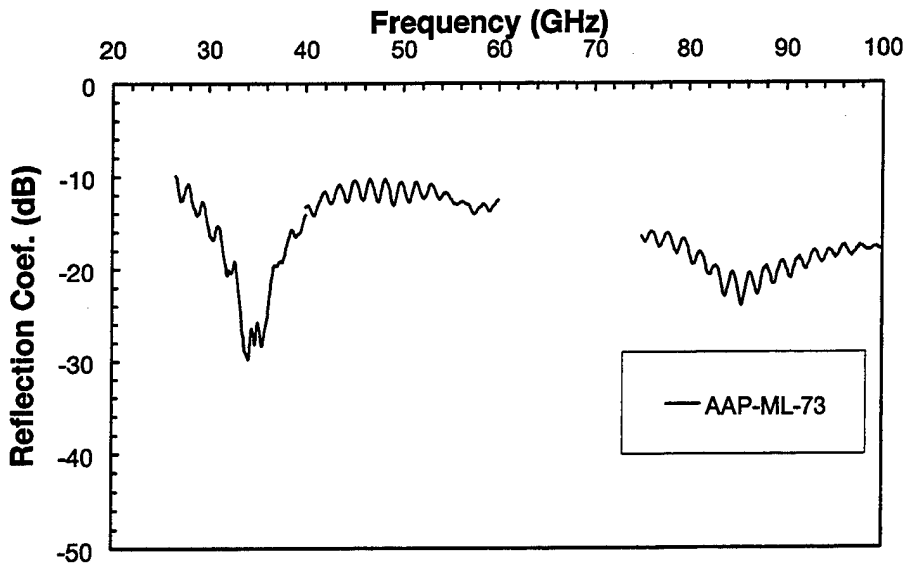

(a) Parallel

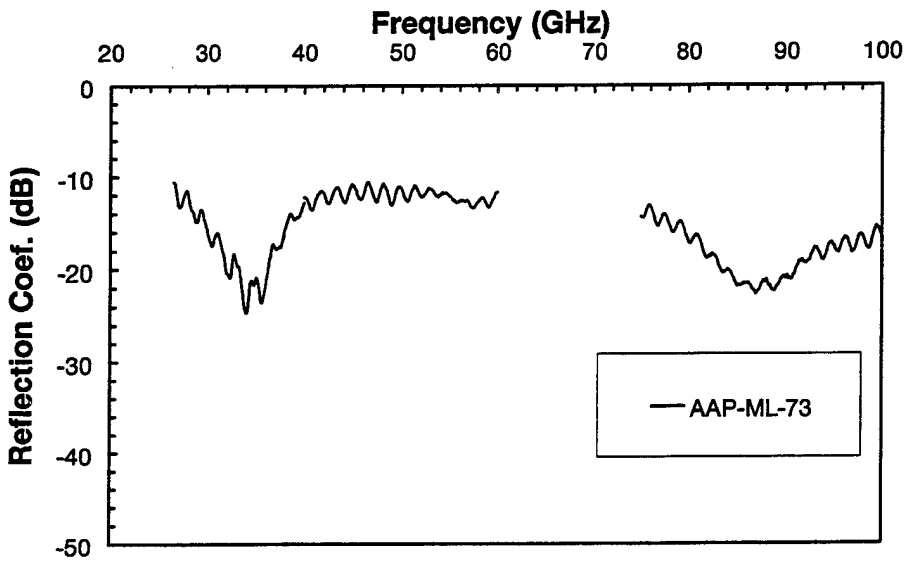

(b) Perpendicular

Figure 8. Reflectivity From 26.5–100 GHz for AAP ML-73 RAM at 47° (Off-Normal) Angle of Incidence.

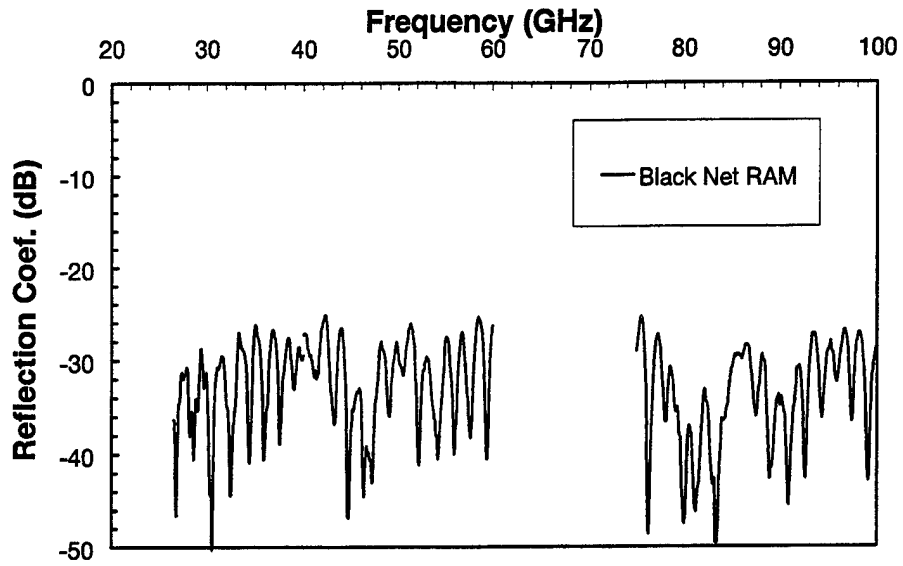

(a) Parallel

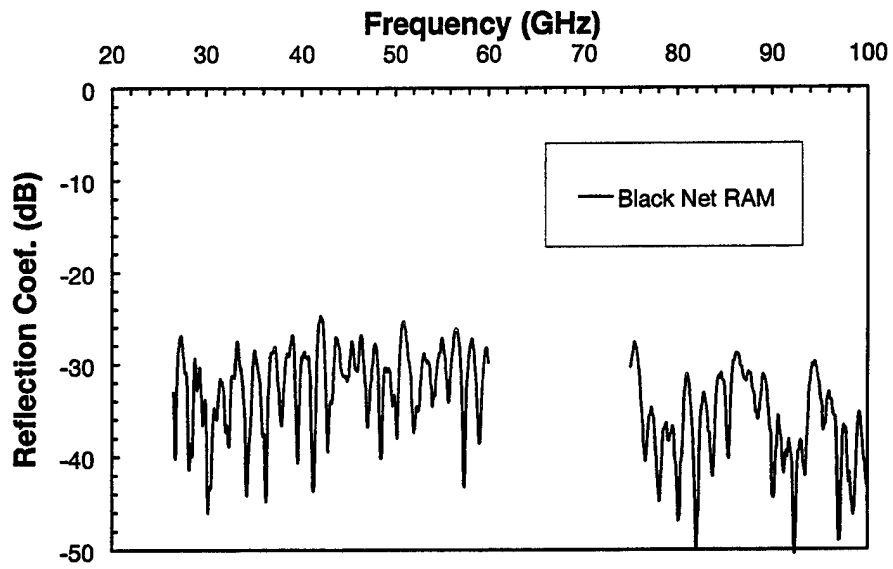

(b) Perpendicular

Figure 9. Reflectivity From 26.5–100 GHz for Black Net RAM at 47° (Off Normal) Angle of Incidence.

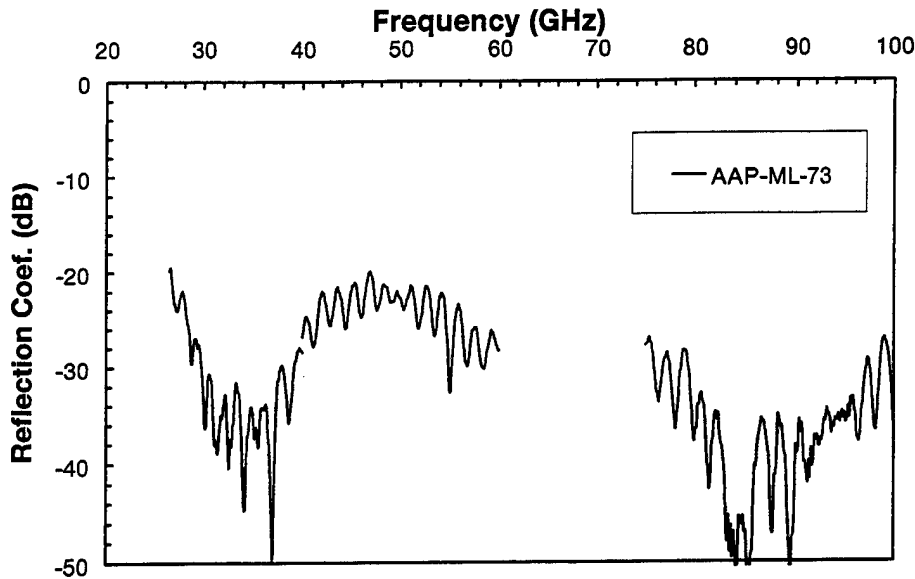

Figure 10. Reflectivity From 26.5–100 GHz of AAP ML-73 RAM Covered Dihedral at 47° (Off Normal) Angle of Incidence.

4. Conclusions

A comparison of the reflection coefficient data from the standard mount (near-normal incidence) with the data obtained with the sample on the dihedral mount (47° incidence) can be made for the two commercial sample types. This illustrates how differing RAM designs can vary greatly in performance at different angles of incidence of the radar signals. A RAM or RACO material to be utilized in camouflaging military systems with complex (not low observable) shapes should have good performance at normal angle of incidence and a sufficient performance at off-normal angles so that, in a double- or triple-bounce configuration, it performs as well or better than at normal incidence. A vehicle or aircraft designed from the start to have little or no complex shapes providing multiple bounces would not need a RAM or RACO material with this ability.

This novel and simple dihedral RAM sample test mount allows for testing the performance of RAM and RACO designs at off-normal incidence (~47°) and in a double-bounce configuration.

<u>NO. OF COPIES</u>	<u>ORGANIZATION</u>
2	DEFENSE TECHNICAL INFORMATION CENTER DTIC DDA 8725 JOHN J KINGMAN RD STE 0944 FT BELVOIR VA 22060-6218
1	HQDA DAMO FDQ D SCHMIDT 400 ARMY PENTAGON WASHINGTON DC 20310-0460
1	OSD OUSD(A&T)/ODDDR&E(R) R J TREW THE PENTAGON WASHINGTON DC 20301-7100
1	DPTY CG FOR RDA US ARMY MATERIEL CMD AMCRDA 5001 EISENHOWER AVE ALEXANDRIA VA 22333-0001
1	INST FOR ADVNCD TCHNLGY THE UNIV OF TEXAS AT AUSTIN PO BOX 202797 AUSTIN TX 78720-2797
1	DARPA B KASPAR 3701 N FAIRFAX DR ARLINGTON VA 22203-1714
1	NAVAL SURFACE WARFARE CTR CODE B07 J PENNELLA 17320 DAHLGREN RD BLDG 1470 RM 1101 DAHLGREN VA 22448-5100
1	US MILITARY ACADEMY MATH SCI CTR OF EXCELLENCE DEPT OF MATHEMATICAL SCI MADN MATH THAYER HALL WEST POINT NY 10996-1786

<u>NO. OF COPIES</u>	<u>ORGANIZATION</u>
1	DIRECTOR US ARMY RESEARCH LAB AMSRL DD J J ROCCHIO 2800 POWDER MILL RD ADELPHI MD 20783-1197
1	DIRECTOR US ARMY RESEARCH LAB AMSRL CS AS (RECORDS MGMT) 2800 POWDER MILL RD ADELPHI MD 20783-1145
3	DIRECTOR US ARMY RESEARCH LAB AMSRL CI LL 2800 POWDER MILL RD ADELPHI MD 20783-1145
	<u>ABERDEEN PROVING GROUND</u>
4	DIR USARL AMSRL CI LP (BLDG 305)

<u>NO. OF COPIES</u>	<u>ORGANIZATION</u>
2	DIR USARL AMSRL CP CA D SNIDER AMSRL SE L D WOODBURY 2800 POWDER MILL ROAD ADELPHI MD 20783-1145
1	CDR USARDEC AMSTA AR FSE T GORA PICATINNY ARSENAL NJ 07806-5000
3	CDR USARDEC AMSTA AR TD J HEDDERICH V LINDNER C SPINELLI PICATINNY ARSENAL NJ 07806-5000
5	US ARMY TACOM AMSTA JSK S GOODMAN J FLORENCE AMSTA TR D B RAJU L HINOJOSA D OSTBERG WARREN MI 48397-5000
5	PM SADARM SFAE GCSS SD COL B ELLIS M DEVINE W DEMASSI J PRITCHARD S HROWNAK PICATINNY ARSENAL NJ 07806-5000
1	CDR USARDEC AMSTA AR CCH S MUSALLI PICATINNY ARSENAL NJ 07806-5000
1	CDR USARDEC AMSTA AR CCH V E FENNELL PICATINNY ARSENAL NJ 07806-5000

<u>NO. OF COPIES</u>	<u>ORGANIZATION</u>
2	CDR USARDEC AMSTA AR PICATINNY ARSENAL NJ 07806-5000
1	CDR USARDEC AMSTA AR CCH P J LUTZ PICATINNY ARSENAL NJ 07806-5000
2	CDR USARDEC AMSTA AR M D DEMELLA F DIORIO PICATINNY ARSENAL NJ 07806-5000
3	CDR USARDEC AMSTA AR FSA A WARNASH B MACHAK C CHIEFA PICATINNY ARSENAL NJ 07806-5000
9	DIR BENET LABORATORIES AMSTA AR CCB J KEANE J BATTAGLIA J VASILAKIS G FFIAR V MONTVORI J WRZUCHALSKI R HASENBEIN G D ANDREN AMSTA AR CCB R S SOPOK WATERVLIET NY 12189
1	CDR SMCWV QAE Q B VANINA BLDG 44 WATERVLIET ARSENAL WATERVLIET NY 12189-4050
1	CDR SMCWV SPM T MCCLOSKEY BLDG 253 WATERVLIET ARSENAL WATERVLIET NY 12189-4050

NO. OF
COPIES ORGANIZATION

1 CDR
WATERVLIET ARSENAL
SMCWV QA QS K INSCO
WATERVLIET NY 12189-4050

1 CDR USARDEC
PRODUCTION BASE MODERN ACTY
AMSMC PBM K
PICATINNY ARSENAL NJ
07806-5000

1 CDR
US ARMY BELVOIR RD&E CTR
STRBE JBC
FT BELVOIR VA 22060-5606

2 CDR USARDEC
AMSTA AR FSP G
M SCHIKSNIS
D CARLUCCI
PICATINNY ARSENAL NJ
07806-5000

3 CDR
US ARMY AVIATION AND
MISSILE CMD
AMSMI RD W MCCORKLE
AMSMI RD ST P DOYLE
AMSMI RD ST CN T VANDIVER
REDSTONE ARSENAL AL
35898-5247

1 US ARMY RESEARCH OFFICE
A CROWSON
PO BOX 12211
RESEARCH TRIANGLE PARK NC
27709-2211

2 US ARMY RESEARCH OFFICE
ENGINEERING SCIENCES DIV
R SINGLETON
G ANDERSON
PO BOX 12211
RESEARCH TRIANGLE PARK NC
27709-2211

NO. OF
COPIES ORGANIZATION

3 PM TMAS
SFAE GSSC TMA
COL PAWLICKI
K KIMKER
E KOPACZ
PICATINNY ARSENAL NJ
07806-5000

1 PM TMAS
SFAE GSSC TMA SMD R KOWALSKI
PICATINNY ARSENAL NJ
07806-5000

2 FIRE SUPPORT ARMAMENTS CTR
STEVE FLOROFF
MAJ D SKALSKY
BLDG 61 NORTH
PICATINNY ARSENAL NJ
07806-5000

2 PEO FIELD ARTILLERY SYSTEMS
SFAE FAS PM
H GOLDMAN
T MCWILLIAMS
PICATINNY ARSENAL NJ
07806-5000

2 PM CRUSADER
G DELCOCO
J SHIELDS
PICATINNY ARSENAL NJ
07806-5000

1 US ARMY TACOM
SIORI XC F DEARBORN
ROCK ISLAND ARSENAL IL
61299-6000

1 CDR XVIII ABN CORPS ARTY
BG MILLER
FT BRAGG NC 28307-5000

2 NASA LANGLEY RESEARCH CTR
MS 266
AMSRL VS
W ELBER
F BARTLETT JR
HAMPTON VA 23681-0001

NO. OF
COPIES ORGANIZATION

1 NSWC
DAHLGREN DIV
CODE G06
DAHLGREN VA 22448

1 OFFICE OF NAVAL RESEARCH
MECH DIV CODE 1132SM
Y RAJAPAKSE
ARLINGTON VA 22217

2 NSWC
R HUBBARD G33-C
J H FRANCIS G30
DAHLGREN DIV
DAHLGREN VA 22448-5000

1 OFFICE OF NAVAL RES
J KELLY
800 NORTH QUINCEY ST
ARLINGTON VA 22217-5000

2 DAVID TAYLOR RESEARCH CTR
R ROCKWELL
W PHYLLAIER
BETHESDA MD 20054-5000

1 EXPEDITIONARY WARFARE
DIV N85
F SHOUP
2000 NAVY PENTAGON
WASHINGTON DC 20350-2000

1 OFFICE OF NAVAL RESEARCH
D SIEGEL 351
800 N QUINCY ST
ARLINGTON VA 22217-5660

1 CDR NAVAL SEA SYSTEMS CMD
D LIESE
2531 JEFFERSON DAVIS HWY
ARLINGTON VA 22242-5160

2 NSWC
M E LACY CODE B02
TECH LIBRARY CODE 323
17320 DAHLGREN RD
DAHLGREN VA 22448

NO. OF
COPIES ORGANIZATION

1 MARINE CORPS SYS CMD
PM GROUND WPNS
COL R OWEN
2083 BARNETT AVE SUITE 315
QUANTICO VA 22134-5000

1 LANL
J REPPA
MS F668
PO BOX 1633
LOS ALAMOS NM 87545

1 PACIFIC NORTHWEST LABORATORY
M SMITH
PO BOX 999
RICHLAND WA 99352

1 AAI CORPORATION
T G STASTNY
PO BOX 126
HUNT VALLEY MD 21030-0126

1 SAIC
D DAKIN
2200 POWELL ST STE 1090
EMERYVILLE CA 94608

1 SAIC
M PALMER
1710 GOODRIDGE DR
MCLEAN VA 22102

1 SAIC
J GLISH
3800 W 80TH ST SUITE 1910
BLOOMINGTON MN 55431

1 SAIC
R ACEBAL
1225 JOHNSON FERRY RD STE 100
MARIETTA GA 30068

1 SAIC
G CHRYSSOMALLIS
3800 W 80TH STREET
STE 1090
BLOOMINGTON MN 55431

<u>NO. OF</u> <u>COPIES</u>	<u>ORGANIZATION</u>	<u>NO. OF</u> <u>COPIES</u>	<u>ORGANIZATION</u>
2	ALLIANT TECHSYSTEMS INC C CANDLAND R BECKER 600 2ND ST NE HOPKINS MN 55343-8367	1	CDR USARDEC T SACHAR INDUSTRIAL ECOLOGY CTR BLDG 172 PICATINNY ARSENAL NJ 07806-5000
1	CUSTOM ANALYTICAL ENGR SYS INC A ALEXANDER 13000 TENSOR LANE NE FLINTSTONE MD 21530	1	CDR USA ATCOM AVIATION APPLIED TACH DIR J SCHUCK FT EUSTIS VA 23604-1104
1	NOESIS INC ALLEN BOUTZ 1110 N GLEBE RD STE 250 ARLINGTON VA 22201-4795	1	CDR USARDEC AMSTA AR SRE D YEE PICATINNY ARSENAL NJ 07806-5000
5	GEN CORP AEROJET D PILLASCH T COULTER C FLYNN D RUBAREZUL M GREINER 1100 W HOLLYVALE ST AZUSA CA 91702-0296	1	INTERFEROMETRICS INC R LARRIVA 8150 LEESBURG PIKE VIENNA VA 22100
1	GENERAL DYNAMICS LAND SYSTEMS DIVISION D BARTLE PO BOX 1901 WARREN MI 48090	1	PM ADVANCED CONCEPTS LORAL VOUGHT SYSTEMS J TAYLOR PO BOX 650003 MS WT 21 DALLAS TX 76265-0003
1	INSTITUTE FOR ADVANCED TECH T KIEHNE H FAIR P SULLIVAN W REINECKE I MCNAB 4030 2 W BRAKER LN AUSTIN TX 78759	2	LORAL VOUGHT SYSTEMS G JACKSON K COOK 1701 W MARSHALL DR GRAND PRAIRIE TX 75051
5	INSTITUTE FOR ADVANCED TECH T KIEHNE H FAIR P SULLIVAN W REINECKE I MCNAB 4030 2 W BRAKER LN AUSTIN TX 78759	1	BRIGS CO J BACKOFEN 2668 PETERBOROUGH ST HERDON VA 22071-2443
2	D ROSE IIT RESEARCH CENTER 201 MILL ST ROME NY 13440-6916	1	SOUTHWEST RESEARCH INSTITUTES J RIEGEL ENGR AND MATERIAL SCIENCES DIV 6220 CULEBRA RD PO DRAWER 28510 SAN ANTONIO TX 78228-0510

<u>NO. OF</u> <u>COPIES</u>	<u>ORGANIZATION</u>
1	R EICHELBERGER 409 W CATHERINE ST BEL AIR MD 21014-3613
1	LLNL M MURPHY PO BOX 808 L 282 LIVERMORE CA 94550
2	MARTIN MARIETTA CORP P DEWAR L SPONAR 230 EAST GODDARD BLVD KING OF PRUSSIA PA 19406
2	OLIN CORP FLINCHBAUGH DIV E STEINER B STEWART PO BOX 127 RED LION PA 17356
1	OLIN CORP L WHITMORE 10101 9TH ST NORTH ST PETERSBURG FL 33702
1	SPARTA INC J GLATZ 9455 TOWNE CTR DR SAN DIEGO CA 92121-1964
2	UDLP P PARA G THOMAS 1107 COLEMAN AVE BOX 367 SAN JOSE CA 95103
1	OAK RIDGE NATIONAL LABORATORY R M DAVIS PO BOX 2008 OAK RIDGE TN 37831-6195
3	UDLP 4800 EAST RIVER RD P JANKE MS170 T GIOVANETTI MS236 B VAN WYK MS389 MINNEAPOLIS MN 55421-1498

<u>NO. OF</u> <u>COPIES</u>	<u>ORGANIZATION</u>
6	DIRECTOR US ARMY RESEARCH LAB AMSRL WM MB A ABRAHAMIAN M BERMAN A FRYDMAN T LI W MCINTOSH E SZYMANSKI 2800 POWDER MILL RD ADELPHI MD 20783-1145
	<u>ABERDEEN PROVING GROUND</u>
60	DIR USARL AMSRL CI H C NIETUBICZ 394 AMSRL WM B A HORST 390A AMSRL WM BA W D AMICO 120 AMSRL WM BB T VONG 120 AMSRL WM BC P PLOSTINS 390 D LYON 390 J NEWILL 390 S WILKERSON 390 AMSRL WM BD R FIFER 390 B FORCH 390A R PESCE-RODRIGUEZ 390 B RICE 390A M MCQUAID 390 P REEVES 390 AMSRL WM BE G KELLER 390 C LEVERITT 390 D KOOKER 390A J DESPIRITO 390 S HOWARD 390 G KATULKA 390 G WREN 390 AMSRL WM BP E SCHMIDT 390A AMSRL WM M D VIECHNICKI 4600 G HAGNAUER 4600 J MCCAULEY 4600

NO. OF
COPIES ORGANIZATION

ABERDEEN PROVING GROUND (CONT)

AMSRL WM MA
R SHUFORD 4600
S MCKNIGHT 4600
AMSRL WM MB
W DRYSDALE 4600
B BURNS 4600
L BURTON 4600
J BENDER 4600
T BLANAS 4600
T BOGETTI 4600
R BOSSOLI 120 (5 CPS)
J CONNORS 4600
S CORNELISON 120
P DEHMER 4600
R DOOLEY 4600
B FINK 4600
G GAZONAS 4600
D GRANVILLE 4600
S GHIORSE 4600
D HOPKINS 4600
C HOPPEL 4600
D HENRY 4600
R KASTE 4600
R KLINGER 4600
M LEADORE 4600
R LIEB 4600
E RIGAS 4600
D SPAGNUOLO 4600
W SPURGEON 4600
J TZENG 4600
AMSRL WM MC
T HYNES 4600
AMSRL WM MD
W ROY 4600
AMSRL WM T
W MORRISON 309
AMSRL WM TE
A NILER 120
G THOMSON 120
P BERNING 120
M MCNEIR 120

INTENTIONALLY LEFT BLANK.

REPORT DOCUMENTATION PAGE

Form Approved
OMB No. 0704-0188

Public reporting burden for this collection of information is estimated to average 1 hour per response, including the time for reviewing instructions, searching existing data sources, gathering and maintaining the data needed, and completing and reviewing the collection of information. Send comments regarding this burden estimate or any other aspect of this collection of information, including suggestions for reducing this burden, to Washington Headquarters Services, Directorate for Information Operations and Reports, 1215 Jefferson Davis Highway, Suite 1204, Arlington, VA 22202-4302, and to the Office of Management and Budget, Paperwork Reduction Project (0704-0188), Washington, DC 20503.

1. AGENCY USE ONLY (Leave blank)		2. REPORT DATE September 1999	3. REPORT TYPE AND DATES COVERED Final, Jun 98-Dec 98	
4. TITLE AND SUBTITLE A Dihedral Sample Mount for Off-Normal RAM Performance Measurements			5. FUNDING NUMBERS 1L161102AH43	
6. AUTHOR(S) Robert B. Bossoli				
7. PERFORMING ORGANIZATION NAME(S) AND ADDRESS(ES) U.S. Army Research Laboratory ATTN: AMSRL-WM-MB Aberdeen Proving Ground, MD 21005-5069			8. PERFORMING ORGANIZATION REPORT NUMBER ARL-TR-2049	
9. SPONSORING/MONITORING AGENCY NAMES(S) AND ADDRESS(ES)			10. SPONSORING/MONITORING AGENCY REPORT NUMBER	
11. SUPPLEMENTARY NOTES				
12a. DISTRIBUTION/AVAILABILITY STATEMENT Approved for public release; distribution is unlimited.			12b. DISTRIBUTION CODE	
13. ABSTRACT (Maximum 200 words) A novel sample mount has been designed for making high angle of incidence radar-absorbing material (RAM) sample performance measurements. The sample mount allows for ~47° angle of incidence measurement of RAM millimeter-wave (MMW) reflectivity (performance). Measurements are taken from 26–60 GHz and 75–100 GHz in the U.S. Army Research Laboratory's (ARL) Weapons and Materials Research Directorate (WMRD) Composites and Lightweight Structures Branch (CLSB) anechoic chamber. RAM samples can also be mounted in a full dihedral configuration for simulation of RAM performance in double bounce (corner)-type locations. Performance of two commercial-type RAM materials was measured at close to normal and at the ~47° off-normal angles of incidence. A full dihedral covered with one of the commercial RAMs was also tested. The mount will allow for more realistic evaluation of ARL- and contractor-designed RAM and other coatings to be utilized in low-observable Army and Department of Defense (DOD) projects.				
14. SUBJECT TERMS radar-absorbing material (RAM), reflectivity, off-normal performance, millimeterwave (MMW)			15. NUMBER OF PAGES 28	
			16. PRICE CODE	
17. SECURITY CLASSIFICATION OF REPORT UNCLASSIFIED	18. SECURITY CLASSIFICATION OF THIS PAGE UNCLASSIFIED	19. SECURITY CLASSIFICATION OF ABSTRACT UNCLASSIFIED	20. LIMITATION OF ABSTRACT UL	

INTENTIONALLY LEFT BLANK.

USER EVALUATION SHEET/CHANGE OF ADDRESS

This Laboratory undertakes a continuing effort to improve the quality of the reports it publishes. Your comments/answers to the items/questions below will aid us in our efforts.

1. ARL Report Number/Author ARL-TR-2049 (Bossoli) Date of Report September 1999
2. Date Report Received _____
3. Does this report satisfy a need? (Comment on purpose, related project, or other area of interest for which the report will be used.) _____

4. Specifically, how is the report being used? (Information source, design data, procedure, source of ideas, etc.) _____

5. Has the information in this report led to any quantitative savings as far as man-hours or dollars saved, operating costs avoided, or efficiencies achieved, etc? If so, please elaborate. _____

6. General Comments. What do you think should be changed to improve future reports? (Indicate changes to organization, technical content, format, etc.) _____

CURRENT
ADDRESS

Organization

Name

E-mail Name

Street or P.O. Box No.

City, State, Zip Code

7. If indicating a Change of Address or Address Correction, please provide the Current or Correct address above and the Old or Incorrect address below.

OLD
ADDRESS

Organization

Name

Street or P.O. Box No.

City, State, Zip Code

(Remove this sheet, fold as indicated, tape closed, and mail.)
(DO NOT STAPLE)