

REPORT DOCUMENTATION PAGEForm Approved
OMB No. 0704-0188

Public reporting burden for this collection of information is estimated to average 1 hour per response, including the time for reviewing instructions, searching existing data sources, gathering and maintaining the data needed, and completing and reviewing the collection of information. Send comments regarding this burden estimate only, other aspect of this collection of information, including suggestions for reducing this burden, to Washington Headquarters Services, Directorate for Information Operations and Reports, 1215 Jefferson Davis Highway, Suite 1204, Arlington, VA 22202-4302, and to the Office of Management and Budget, Paperwork Reduction Project (07804-0188), Washington, DC 20503.

1. AGENCY USE ONLY (LEAVE BLANK)		2. REPORT DATE 3 August 1999	3. REPORT TYPE AND DATES COVERED Professional Paper	
4. TITLE AND SUBTITLE Risk Management of an Aging KC-130 Fleet			5. FUNDING NUMBERS	
6. AUTHOR(S) Paul Hoffman Jennifer Miller Margery Hoffman James Candella				
7. PERFORMING ORGANIZATION NAME(S) AND ADDRESS(ES) Naval Air Warfare Center Aircraft Division 22347 Cedar Point Road, Unit #6 Patuxent River, Maryland 20670-1161			8. PERFORMING ORGANIZATION REPORT NUMBER	
9. SPONSORING/MONITORING AGENCY NAME(S) AND ADDRESS(ES) Naval Air Systems Command 47123 Buse Road, Unit IPT Patuxent River, Maryland 20670-1547			10. SPONSORING/MONITORING AGENCY REPORT NUMBER	
11. SUPPLEMENTARY NOTES				
12a. DISTRIBUTION/AVAILABILITY STATEMENT Approved for public release; distribution is unlimited.			12b. DISTRIBUTION CODE	
13. ABSTRACT (Maximum 200 words) Typically, when one thinks of aging aircraft, safety is what comes to mind. However, another important aspect is readiness, that is the aircraft has to be available and reliable when needed. Prior to the aging aircraft problem by maintaining safety levels, the readiness requirements were satisfied automatically. Now even in satisfying safety demands, the aging aircraft phenomenon can run afoul of readiness. For the aging USMC KC-130 F/R fleet, a damage-tolerant approach ensured that safety would be maintained but it presented a problem in forecasting readiness, aircraft remaining in the inventory. Due to mission changes, the KC-130 F/R fleet is being subjected to higher fatigue loads than were imposed by the previous mission requirements. Consequently, the designated fatigue service limit is being approached at a much faster rate than initially expected. In turn, if the standard retirement criteria (Fatigue Life Expended, FLE index) were implemented, the fleet inventory would be depleted much more rapidly than originally planned. More emphatically, even if the removal from service criterion was set at a higher FLE greater than the standard of 100%, to gain some service time, the readiness issue remains. Because of the present distribution of FLEs for the fleet, the reduction in KC-130 aircraft inventory using even an FLE of 125% as the removal criterion is far greater than the projected acquisition of KC-130 J models.				
14. SUBJECT TERMS KC-130 Fatigue Life Expended (FLE)			15. NUMBER OF PAGES 18	
			16. PRICE CODE	
17. SECURITY CLASSIFICATION OF REPORT Unclassified	18. SECURITY CLASSIFICATION OF THIS PAGE Unclassified	19. SECURITY CLASSIFICATION OF ABSTRACT Unclassified	20. LIMITATION OF ABSTRACT UL	

DTIC QUALITY INSPECTED 4

19991004 296

RISK MANAGEMENT OF AN AGING KC-130 FLEET

P. Hoffman, M. Hoffman, J. Miller and J. Candela
NAVAIRSYSCOM
Structures Division, Code 4.3.3

CLEARED FOR
OPEN PUBLICATION

3 Aug 99

PUBLIC AFFAIRS OFFICE
NAVAL AIR SYSTEMS COMMAND

H. Howard

Abstract

Introduction

Typically, when one thinks of aging aircraft, safety is what comes to mind. However, another important aspect is readiness that is the aircraft has to be available and reliable when needed. Prior to the aging aircraft problem by maintaining safety levels, the readiness requirements were satisfied automatically. Now even in satisfying safety demands, the aging aircraft phenomenon can run afoul of readiness. For the aging USMC KC-130 F/R fleet a damage tolerant approach ensured that safety would be maintained but it presented a problem in forecasting readiness, aircraft remaining in the inventory.

Due to mission changes, the KC-130 F/R fleet is being subjected to higher fatigue loads than were imposed by the previous mission requirements. Consequently the designated fatigue service limit is being approached at a much faster rate than initially expected. In turn, if the standard retirement criteria (Fatigue Life Expended, FLE index) were implemented, the fleet inventory would be depleted much more rapidly than originally planned. More emphatically, even if the removal from service criterion was set at a higher FLE greater than the standard of 100%, to gain some service time, the readiness issue remains. Because of the present distribution of FLEs for the fleet, Figure 1, the reduction in KC-130 aircraft inventory using even an FLE of 125% as the removal criterion is far greater than the projected acquisition of KC-130 J models, Figure 2.

The question became how to realize a huge cost-avoidance (acquiring KC-130 J aircraft earlier and more rapidly than planned) while insuring safety, yet maintaining readiness. To address this dilemma a technical risk management approach was devised to relieve the inventory problem to the highest degree possible, while ensuring safety.

Addressing Safety

The basic guideline for managing a safe fleet has been the FLE index, a cumulative damage index. It is based on a full-scale test to catastrophic failure. The failed component is then checked via fractography to ascertain time to crack initiation, a ten-mil crack. Then the appropriate service time for the severe test load spectrum is specified as one half the time to crack initiation. This factor of two specification results, for all intents and purposes, in a probability of crack initiation (the ten-mil size) of 0.001 for the test spectrum load. This specified service life (one half the crack initiation life) is designated to be at 100% FLE. In other

words the FLE index is viewed as a cumulative damage measure which when an aircraft reaches 100% it is removed from the fleet. Using the strain-life approach, other load spectra can be evaluated for equivalent damage thereby providing a means to individually track aircraft by bureau number (a.k.a. tail number.) and retire each aircraft when it reaches the equivalent damage as was accumulated in half of the test life under the severe spectrum.

In a recent service life assessment program, SLAP, of the KC-130 F/R it was discovered that during the years 1986 through 1990 the missions changed thereby imposing an increase in usage severities than were being used in the strain life analysis for tracking purposes. The net effect was that the KC-130 F/R fleet was further along in FLE consumption than what was predicted. In fact a significant portion of the fleet was expected now to be near or at the FLE limit.

From a safety perspective, four areas were seen as fatigue critical locations, Figure 3. Of the four locations, the center-wing section spar cap was observed as the precursor to failure. The spar cap was observed to have cracked first in the full-scale fatigue test but the other three locations were not significantly behind. Fortunately there are some positive conditions to the problem. First, the fatigue critical location, center-wing spar cap, is a highly damage tolerant fault area, with redundant load paths. Second, a crack is readily detectable as it propagates passed the skin covering and has more than 1150 flight hours before reaching fast fracture. Third, the center-wing section inspections revealed the absence of cracks in the operational aircraft. Fourth, the USAF C-130 fleet is far ahead in equivalent accumulated damage.

To deal with safety, in light of the aforementioned positive conditions, a damage tolerant approach was adopted. An inspection schedule, based on fracture crack growth, was setup to monitor the center-wing section critical areas. The retirement criterion is to remove the aircraft as cracks appear. In essence, the FLE index was replaced by a crack growth based damage tolerant requirement.

Addressing Readiness

While the damage tolerant approach assured safety, the problem of projecting remaining inventory is not straightforward. With the FLE set at some fixed FLE value, e.g. 125%, the inventory is readily projected deterministically. The deterministic projection of the removal of an aircraft, because it has accumulated a FLE totaling 125%, is merely the difference between 125% and the aircraft's present FLE value divided by the annual usage rate. Hence an inventory chart is computed summarily, Figure 2. However for the damage tolerant criteria, that is removal upon observation of a crack, a deterministic projection is impossible. For projection of aircraft remaining in the inventory a probabilistic approach was used that was centered on the time to crack observation. The idea of using crack observation time followed from the retirement criterion for safety, the removal of an aircraft when a crack was observed.

The probability density function for time to crack observation was taken from the C-130 Wing Fatigue Study¹, Figure 4. The density function was based on world fleet cracking data. On the surface, the computation of the reliability of the fleet seemed straight forward,

$$\text{Reliability} = \prod_i (1 - P_n) \quad [1]$$

$$\text{where } P_n = \Phi \left[\log_{10} \frac{(\text{FLE} / 200)}{0.14} \right]$$

For computational purposes, with each aircraft at different accumulated flight hours, each aircraft has a specific probability of failure. Consequently, the area under the density function must be computed from zero flight hours to accumulated flight hours for each aircraft, Figure 3. Then the entire fleet reliability is calculated Equation 1. However, fleet reliability is not the answer to the readiness question that is how many aircraft remain in the fleet at any given future time.

In essence, the readiness computational problem is twofold. First, since each aircraft has a unique probability of failure, there is no way to project how many aircraft will still be in the fleet at any given point in time. Each aircraft has a chance of having a crack, albeit different from aircraft to aircraft. Then each aircraft has some chance of being removed from the fleet at a future point in time. Therefore the number remaining is a random variable. Second, there is no way to deterministically state which of the fleet aircraft would still remain in the inventory at some future date.

What can and was answered was how many aircraft can be expected to remain at some future date and with what confidence. First, all the aircraft FLEs are projected deterministically by the constant usage rate to the future date specified. Next, each probability of each aircraft is computed by the standard normal function Φ , Equation 1. Then one can conceivably calculate the probability of all aircraft remaining crack free, or some subset of the total remaining crack free. To compute the reliability of all remaining at the future date, the probabilities of failure are used in the reliability calculation, Equation 1. However, any combination, for example 90% remaining at some future date, becomes computational intractable. To circumvent this, a Monte Carlo approach was implemented in which 10,000 samples were taken for each of the KC-130 F/R.

Results and Conclusions

The result was a histogram of the number of aircraft remaining at different future dates, Figure 5. To project number remaining, the ninetieth percentile was selected. In other words the number specified represented a 90% confidence that this number of aircraft or more would be remaining in the fleet. As depicted, Figure 5, the 90 percentile is 38 aircraft expected for the year 2002. Such computations were performed for years 1998 through 2022. The result was a probabilistic projected inventory, Figure 6. In contrast to Figure 2, a more realistic expectation and balanced inventory (total number of KC-130 F/R/J) is projected.

While the number remaining could be probabilistically projected, the designation of what specific aircraft remain can not be stated. In contrast, the deterministic FLE removal criterion since it projects by just adding the product of years and usage rate would show the highest FLE aircraft reaching the criterion first and thus be removed. On the other hand, the probabilistic approach provides for a better inventory control which in turns avoids a huge acquisition costs not originally planned as early as the FLE approach would demand to insure readiness.

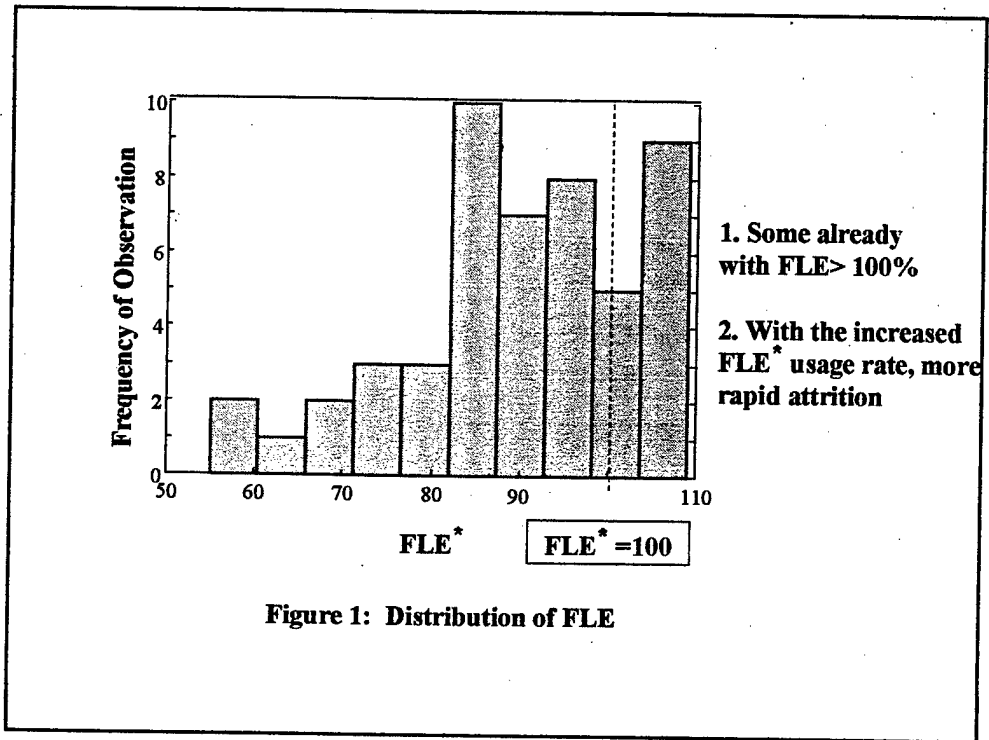

Figure 1: Distribution of FLE

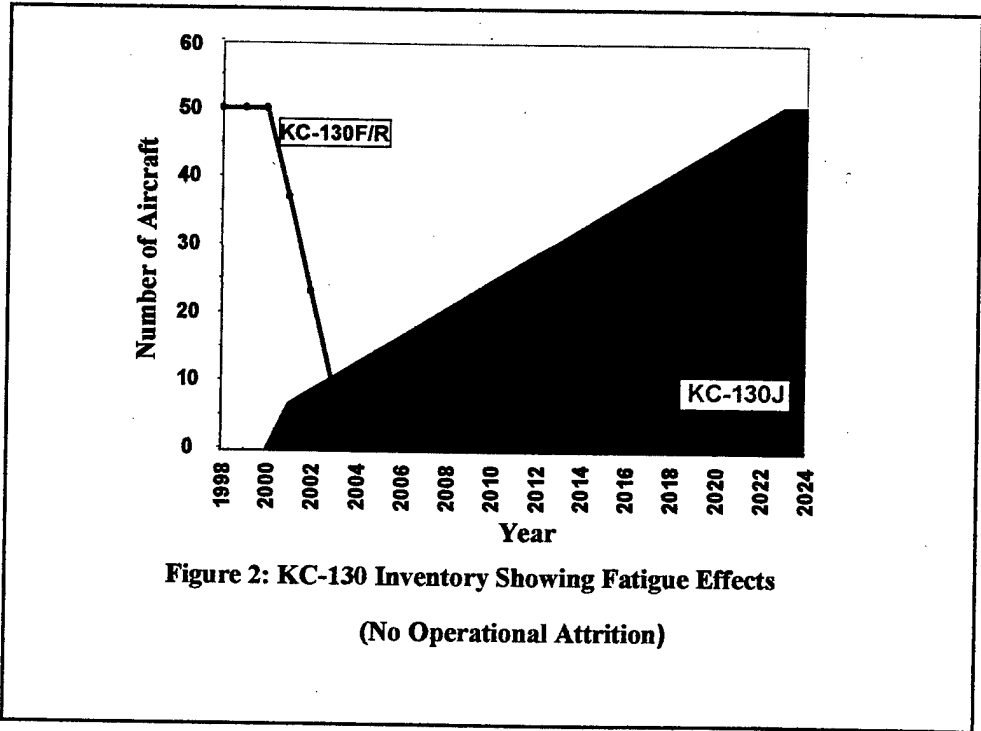

Figure 2: KC-130 Inventory Showing Fatigue Effects
(No Operational Attrition)

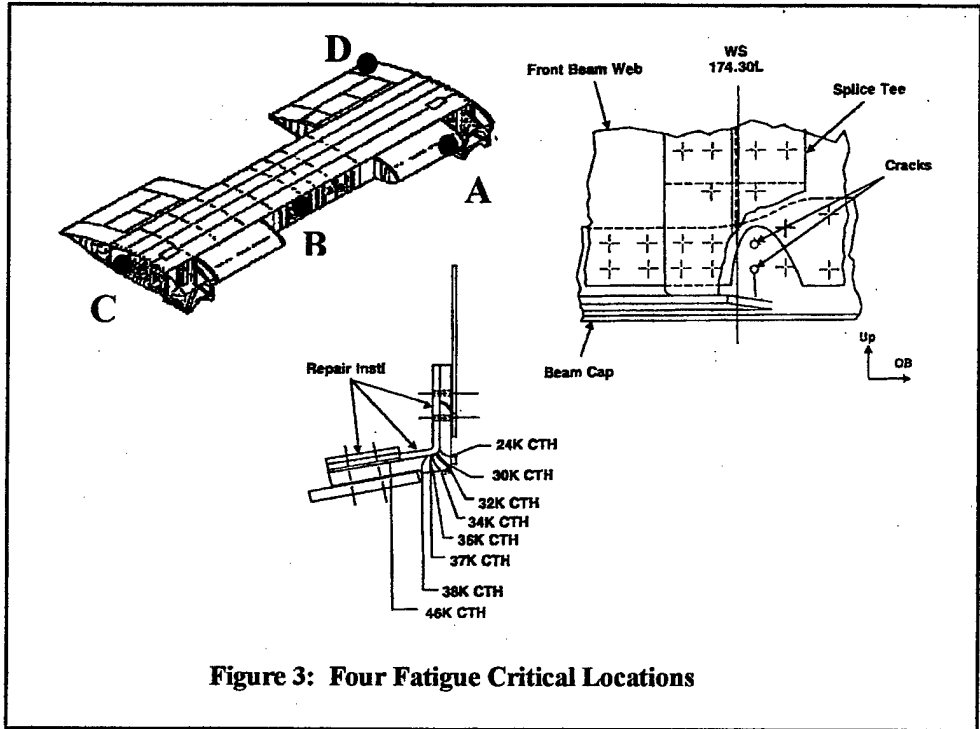

Figure 3: Four Fatigue Critical Locations

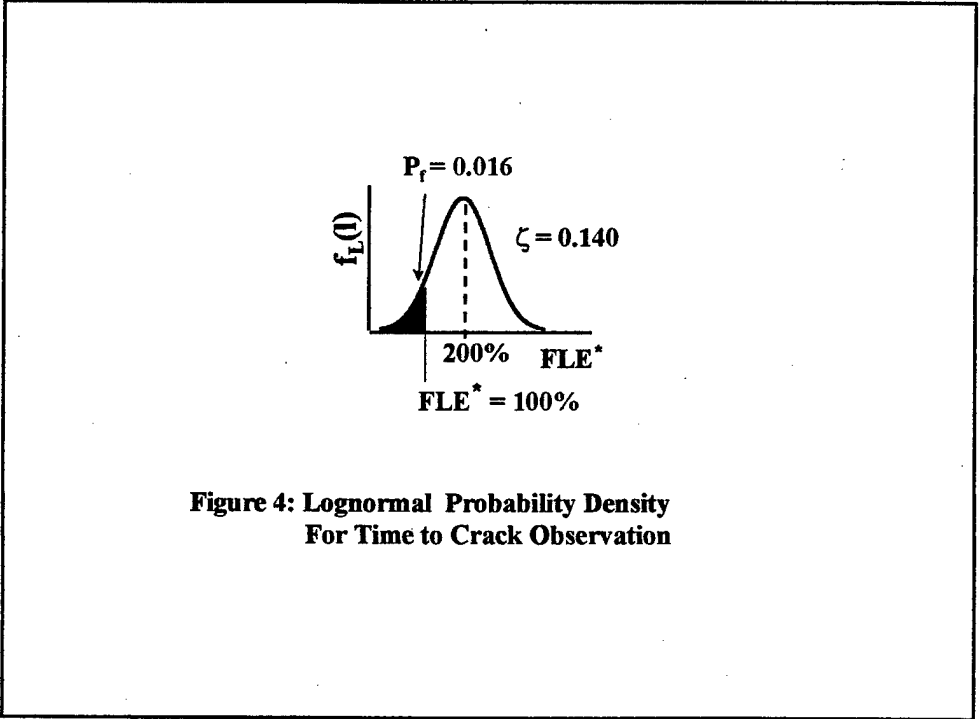
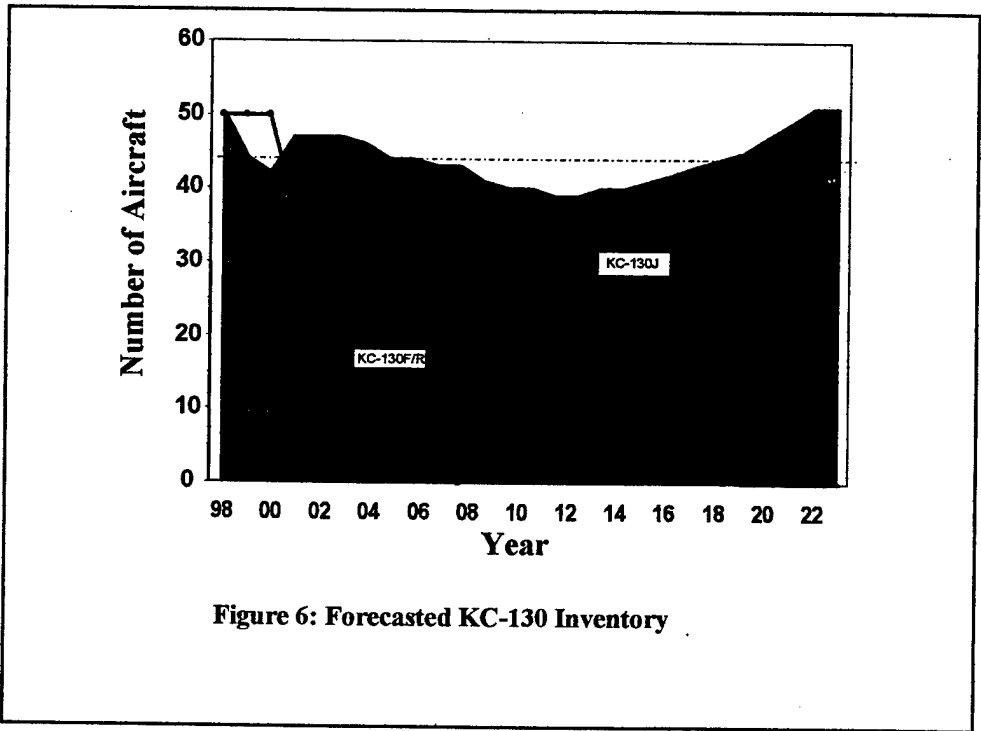
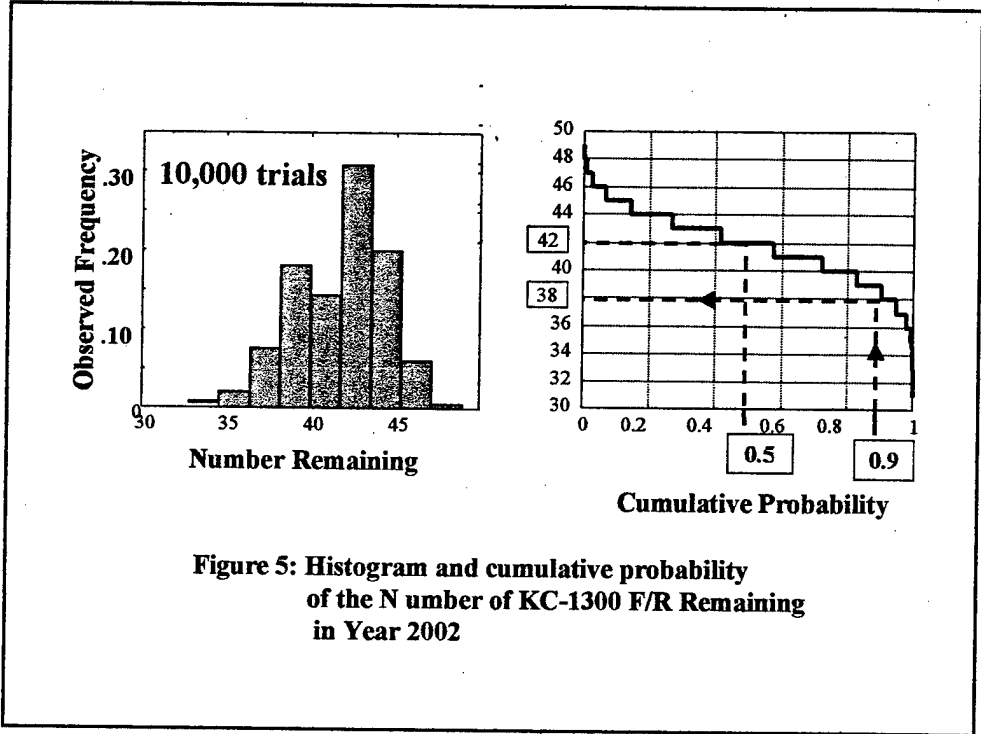
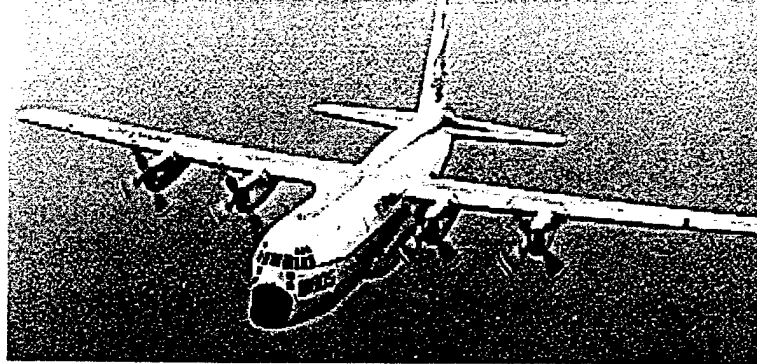

Figure 4: Lognormal Probability Density For Time to Crack Observation



**3rd Joint DOD/FAA/NASA Conference
on Aging Aircraft
Risk Management of an Aging KC-130 Fleet**



by
P. Hoffman, M. Hoffman, J. Miller & J. Candela

Engineering within the Organization's M.O.

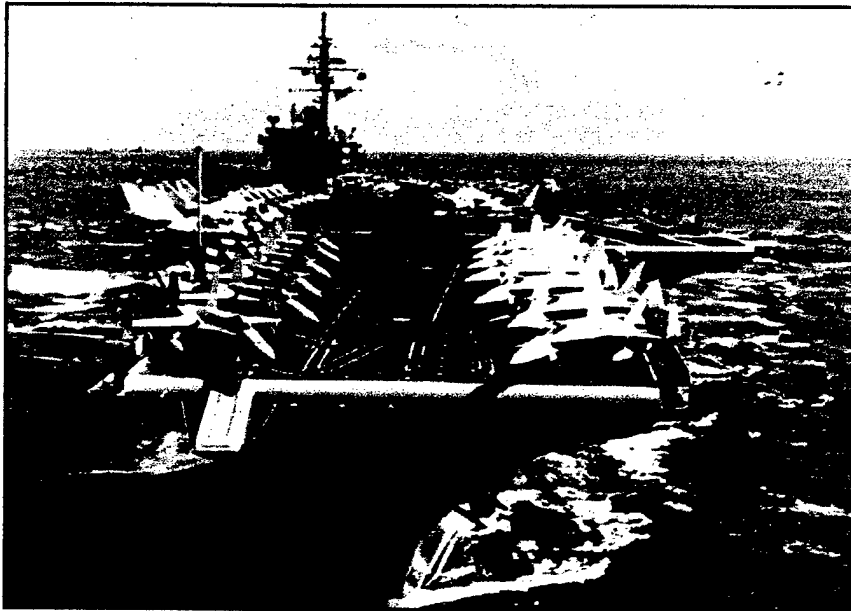

Points to be presented.

- ➔ 1. FLE* Procedure
2. KC- 130 Problem
 - Hitting the FLE 100% wall
 - Safety Issue
 - Logistics Issue
3. Safety Solution
4. Logistics Planning Solution

The Underpinnings of the FLE Approach

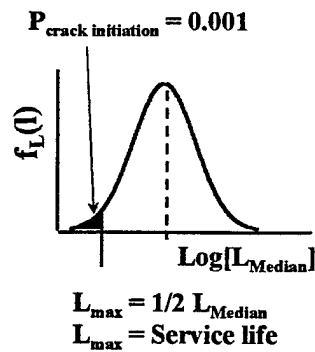

**L = lifetime to crack initiation,
a crack size = 0.01 inches**

- Fatigue lifetime (crack initiation time) is lognormal
- Standard Deviation of Log[fatigue life] = 0.10
- 0.5 median results in a probability of crack initiation of approximately 0.001

Historic Distribution of Crack Findings

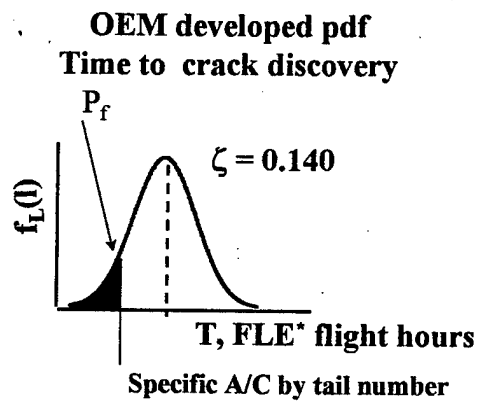
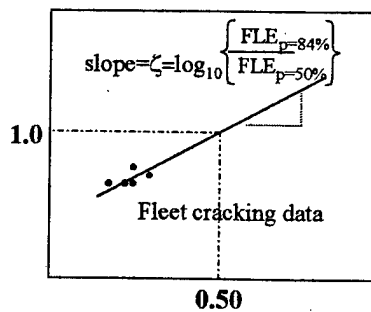

i.e., Probability of no cracks at 100% FLE* = 0.016

Points to be presented.

1. FLE* Procedure
- ➔ 2. KC- 130 Problem
Exceeding the FLE Limit
Safety Issue
Logistics Issue
3. Safety Solution
4. Logistics Planning Solution

The KC-130 FLE problem?

**Gradual Usage Change
1986-1990**
Ramp Up of Usage Severity
 {Pre 1986 $r_1 \sim 3\%$ & Post 1990 $r_2 \sim 5.5\%$ }

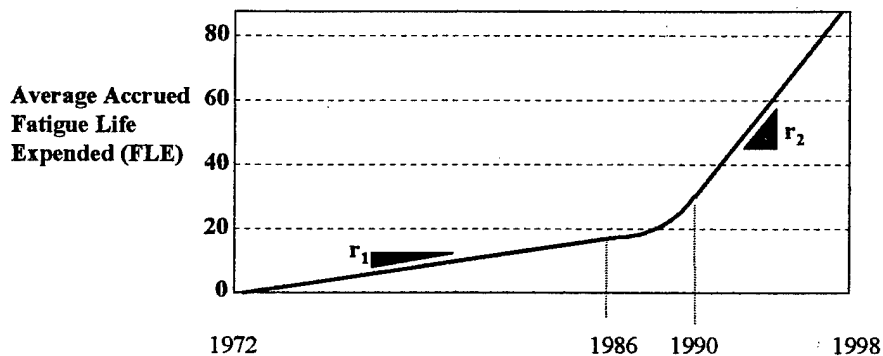

Recalculation: FLEs higher than forecasted

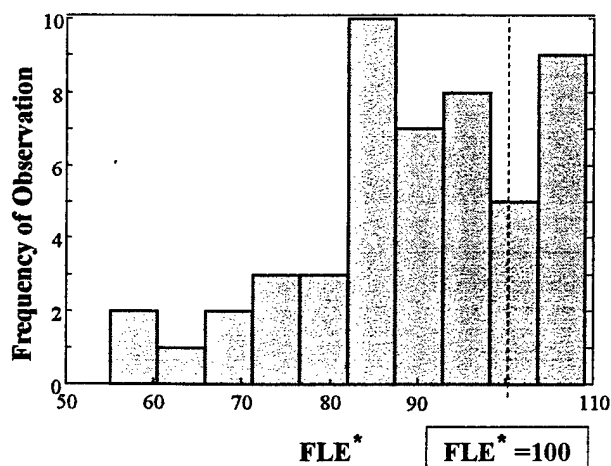

1. Some already with FLE > 100%

2. With the increased FLE* usage rate, more rapid attrition

Two Problems

1st
Foremost and Utmost
SAFETY!

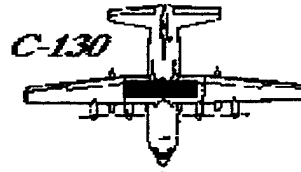

2nd
Inventory (Readiness)

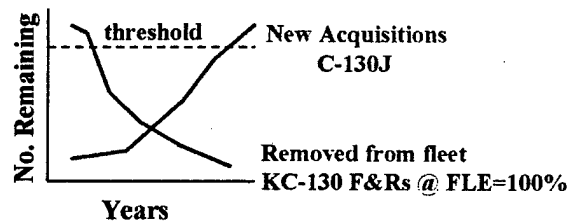

Points to be presented.

1. FLE* Procedure
2. KC- 130 Problem
 - Hitting the FLE 100% wall
 - Safety Issue
 - Logistics Issue
- ➔ 3. Safety Solution
4. Logistics Planning Solution

Center Wing Forward Lower Spar Cap CWS 174

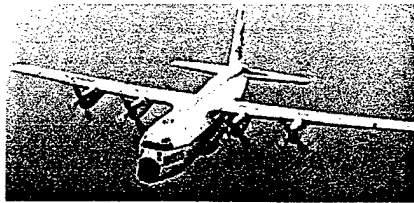

Fatigue-Fracture Issue

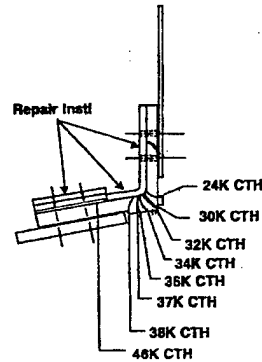
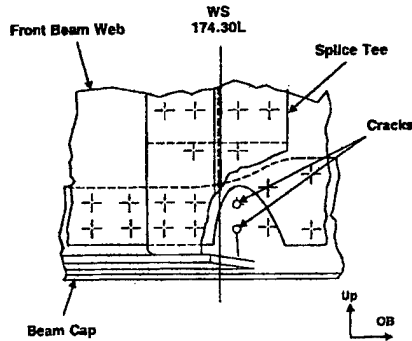

1st (Utmost) Insurance for Safety

- Very damage tolerant fault area - redundant load paths

front beam
web

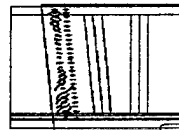

- Excessive crack threshold - readily detected
- USAF C-130 fleet far in the lead
- CWS inspections revealed no cracks in operational aircraft

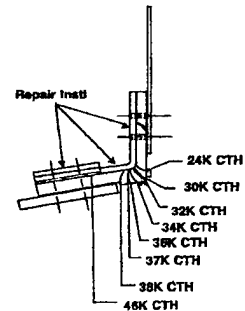

Safety Operational Plan

Set inspection interval (more O&M costs)

- ◇ Size crack would be first visible
- ◇ Projection of time to critical crack size
- ◇ Inspection interval (F.S. = 2)

Retire aircraft as cracks appear

$$N_{\text{inspection}} = \frac{\Delta N}{2}$$

crack length

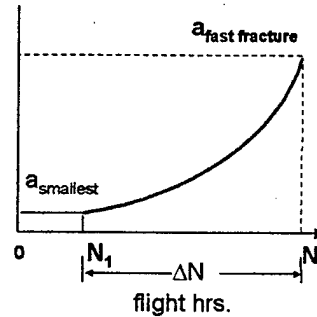

Trading inspection O&M expenditures for more time!

Points to be presented.

1. FLE* Procedure

2. KC- 130 Problem

Hitting the FLE 100% wall

Safety Issue

Logistics Issue

3. Safety Solution

➔ 4. Logistics Planning Solution

2nd Inventory Control (Readiness)

KC-130 Inventory Showing Fatigue Effects (No Operational Attrition)

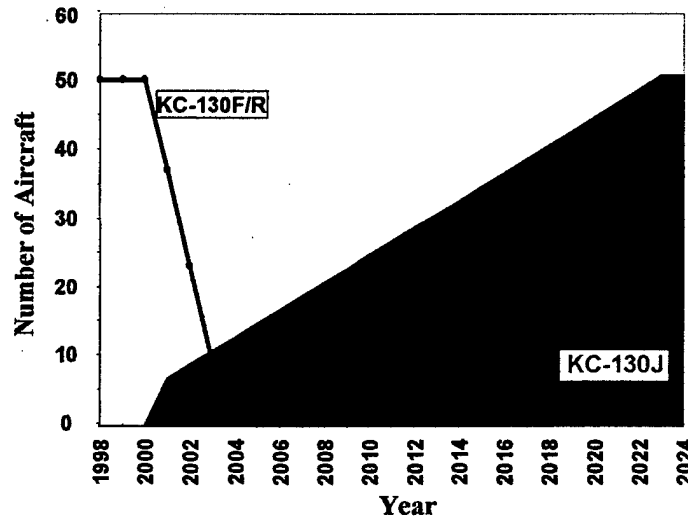

Readiness

KC-130F/R On-Condition Retirement

- **Problem Statement:** How many KC-130 aircraft will be in the fleet in subsequent years?
- **Given:**
 - Revised Removal Criterion,
 - Historic Distribution of Crack Findings,
 - Fleet size,
 - FLEs,
 - FLE/annum.

Inventory (Readiness) Assessments

OEM FLE Approach: @ FLE = 125%, aircraft is removed from the inventory.

When an aircraft, 'i', is at flight hour $t + \Delta t$,

$$FLE_{i,t+\Delta t} = FLE_{i,t} + r\Delta t$$

where

r = usage rate, FLE growth rate

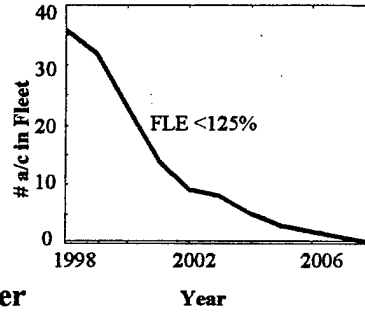

FLE Inventory Control

- **Deterministic**
- **Know attrition by tail number**

New Removal Criterion: Remove when crack is observed.

Reliability Assessment

1. R = Reliability = Probability of no cracks

&

P_f = Probability of Cracking

then

$$R = 1 - P_f$$

- 2. Reliability of fleet consisting of**
two aircraft is $R * R = R^2$.
three aircraft is $R * R * R = R^3$
n aircraft is R^n

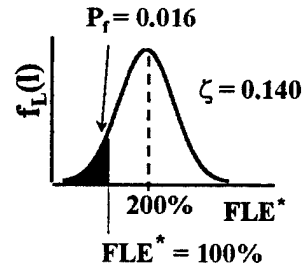

- 3. If a fleet of 50 aircraft reach 100% FLE* and are retired, the probability of having NO cracks is:**

$$R = (1 - 0.016)^{50} = 0.446$$

In contrast, for our standard FLE approach

The lognormal FLE standard deviation is 0.1
 i.e. the standard deviation of $\log_{10}(\text{FLE}) = 0.1$

The associated probability of crack initiation (0.01")
 i.e., @ 100% FLE, is 0.0013, or 13 in 10,000.

A fleet of 50 would have a
 Reliability of:
 $(1 - 0.0013)^{50} = 0.937$

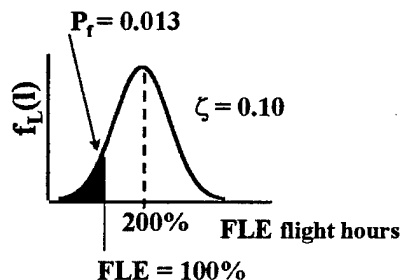

Binomial PMF

$P_f = 0.016 =$ probability of cracking at a given site within the aircraft.

$x =$ number of aircraft with cracks
 $n =$ number of aircraft in the fleet

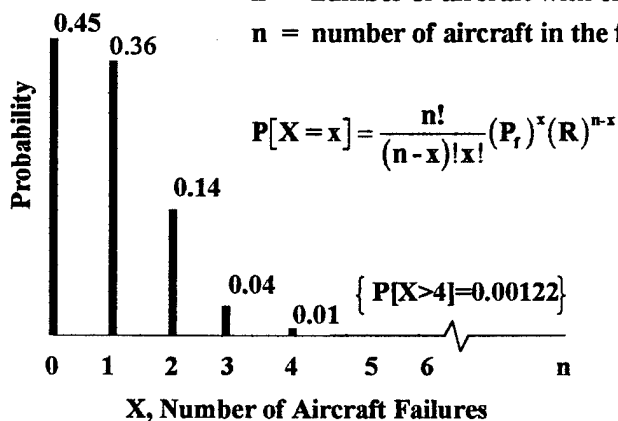

Affect of Changing FLE cut-off.

1st Approach: Sort FLEs in ascending order; calculate the cumulative products of their reliabilities; find the appropriate level of reliability; and retire the rest.

$$R_k = \prod_{i=1}^k (1 - P_i^i), \text{ where } k = 1, 2, \dots, n \text{ \& } P_i^i = \Phi \left[\frac{\log_{10}(\text{FLE}^i / 200)}{0.14} \right]$$

Year	# <100%	R*	<120%	R*
1999	32	0.80	50	.46
2000	23	0.84	47	.39
2001	14	0.90	42	.37
2002	9	0.94	37	.35
2003	8	0.93	31	.36
2004	5	0.96	19	.57

Modeling the Inspection Process

- Use the probability of finding a crack during an inspection as planning tool.
- For a fleet of 50, too many combinations of cracking to enumerate.
 - Monte Carlo simulation was the only practical approach. Used 10,000 trials.
- Calculate the number passing the inspection, for each trial.

Computations

- Probability of 50 crack free aircraft

$$R_k = \prod_{i=1}^{50} (1 - P_r^i), \text{ where } P_r^i = \Phi \left[\frac{\log_{10}(\text{FLE}^i / 200)}{0.14} \right]$$

- Probability of 50 aircraft with just one cracked.

$$\begin{aligned} P[1 \text{ of } 50 \text{ cracked}] &= P_r^1 \left\{ \prod_{i=1} (1 - P_r^i) \right\} + P_r^2 \left\{ \prod_{i=2} (1 - P_r^i) \right\} + \dots \\ &+ P_r^n \left\{ \prod_{i=1} (1 - P_r^n) \right\} \Rightarrow 50 \text{ terms to sum} \end{aligned}$$

Exponential Growth in Combinations

X (number cracked in 50)	Number of terms in sum
0	1
1	50
2	1225
3	19,600
4	230,300
5	2,118,760
6	15,890,700
7	99,884,400
8	536,878,650

Illustration of 4 Fatigue Critical Locations

Failure = cracking with any combination of four locations

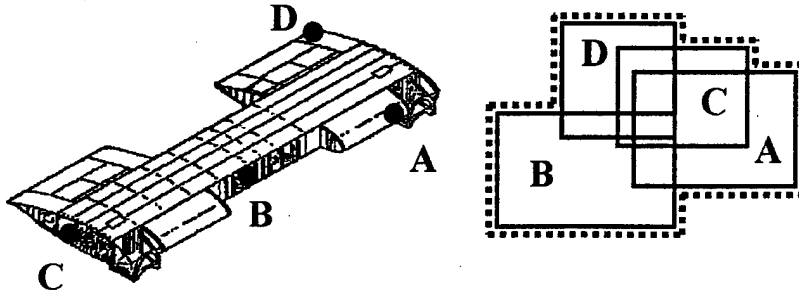

For $P(A)=P(B)=P(C)=P(D)$;

$$P(A \cup B \cup C \cup D) = 4 \cdot P(A) - 6 \cdot P(A)^2 + 4 \cdot P(A)^3 - P(A)^4$$

Simulation

Aircraft numbered from 1 to 50

	1	2	...	k	...	50
1	0	1		1		0
2	1	0	...	1	...	1
3	0	1		1		1
...
j	1	1		0	...	0
...
10,000	0	1		1		0

$\sum_{\text{row 'j'}} =$ Number Remaining per 'j' trial

$\sum_{\text{column, 'k'}} =$ Frequency of AC #k surviving

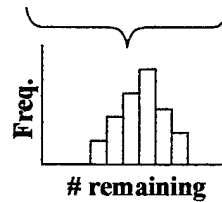

For 2002: Number of KC-130s remaining

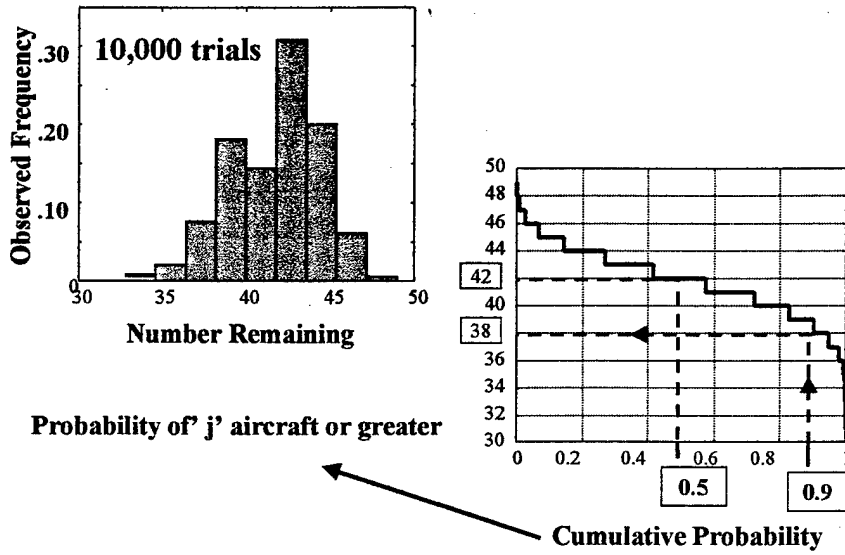

Forecasted KC-130 Inventory

Showing Fatigue Effects - No Operational Attrition

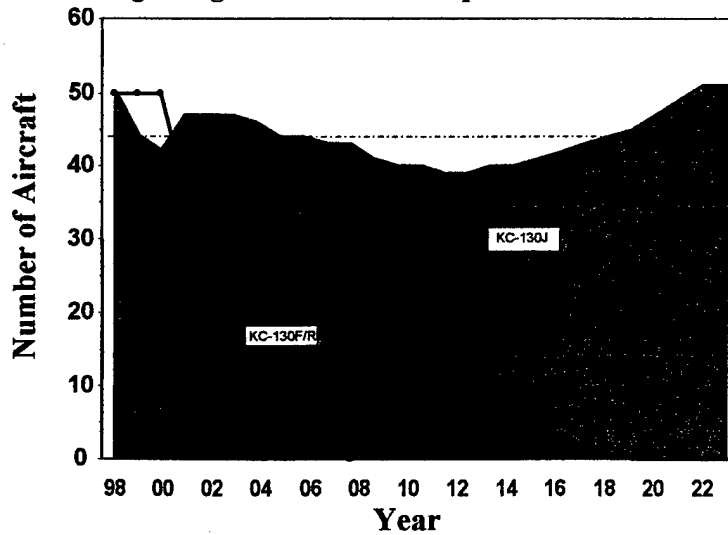

Summary & Closing Remark

- **Presented the solution to a two pronged problem, namely the issues of safety and logistics.**
- **Don't generalized or extrapolate, i.e., it is not for 'all' aircraft!**
- **KC-130 aging safely but with O&M costs.**

— ◆ —

Any Questions?