

OTS: 60-41,173

JPRS: 5308

10 August 1960

SOVIET MACHINE BUILDING

NO. 15

SELECTED TRANSLATIONS

RETURN TO MAIN FILE

19991006 020

Reproduced From
Best Available Copy

DISTRIBUTION STATEMENT A
Approved for Public Release
Distribution Unlimited

Distributed by:

OFFICE OF TECHNICAL SERVICES
U. S. DEPARTMENT OF COMMERCE
WASHINGTON 25, D. C.

Price: \$1.75

U. S. JOINT PUBLICATIONS RESEARCH SERVICE
205 EAST 42nd STREET, SUITE 300
NEW YORK 17, N. Y.

JPRS: 5308

CSO: 2900-N/11
(items 25-34)

SOVIET MACHINE BUILDING

No. 15

SELECTED TRANSLATIONS

Introduction

This is a serial publication containing selected translations of articles on the machine building industry in the Soviet Union. This report consists of translations on subjects listed in the table of contents below.

<u>Table of Contents</u>		<u>Page</u>
1. New Instruments Intended for Mass Production in 1960		1
2. The ITS-1 Instrument (for the Cable Industry)		7
3. Small-Size, Impact-Resistant, Direct-Current Panel Instruments		8
4. Domestically Produced Magnetolectric Oscillographs		11
5. Electrical Measuring Instruments for Infra-Low Frequency Circuits		31
6. Single-Phase Type VMO-35 Oil Circuit Breaker		37
7. Conference on the Utilization of Power Semiconductor Rectifiers in Industrial Enterprises and in Transport		40
8. Series A2 and A02 Three-Phase Induction Electric Motors		45
9. Electrochemical Sources of Current		51
10. Miniature Incandescent Lamps for 110-230 Volts		63

1. New Instruments Intended for Mass Production in 1960

Following is a translation of an article by I. I. Gur'yakov in Priborostroyeniye (Instrument Building), No. 2, February 1960, pages 30-32; CSO: 2900-N/11 (25).7

Miniature electronic automatic indicating and control potentiometers of the PPR4 type and bridges of the MPR4 type of general industrial application.

These potentiometers are intended for the measurement and control of temperature in a set with thermocouples, radiation pyrometers, and electromotive force pickups and the bridges -- in a set with electrical resistance thermometers.

The potentiometers and bridges will be produced with several modifications:

PPR4-01, MPR4-01 -- with a built-in master for electrical proportional and isodromic control with a 100 percent proportionality zone, with one emergency signal device;

PPR4-02, MPR4-02 -- with a position-type single-contact control device and with a built-in device for remote-control transmission of readings;

PPR4-03, MPR4-03 -- with a built-in master for electrical proportional and isodromic control with a 100-percent proportionality zone, with a built-in device for remote-control transmission of readings;

PPR4-04, MPR4-04 -- with a built-in master for electrical proportional and isodromic control, with a 100-percent proportionality zone, with one emergency signal device and with a built-in device for remote-control transmission of readings;

PPR4-05, MPR4-05 -- with a two-position control device;

PPR4-06, MPR4-06 -- with a built-in master for electrical proportional and isodromic control, with a 100-percent proportionality zone and with two emergency signal devices;

PPR4-07, MPR4-07 -- with a position-type, two-contact, control device and with a built-in device for remote-control transmission of readings;

PPR4-08, MPR4-08 -- with a three-position device.

Basic technical characteristics of instruments of PPR4 type

Basic error in %	±0.25
Variation in %, not higher than	±0.25

Threshold of pickup in %	±0.1
Error of operation of contacts of position control device in %, not higher than	±0.5
Over-all dimensions in mm	204x190x405

Feeding of the power system of the instruments is accomplished by alternating current of 127 volts and of a frequency of 50 cycles per second. By varying the feed voltage by 10 percent and the frequency by five percent from the nominal value, the error of the instruments does not exceed the basic error.

Miniature electronic automatic reading and control instruments of the DPR4 type of general industrial application with a differential-transformer system.

These instruments are intended to operate in a set with differential-transformer pickups of pressure, flow, and level. Fig. 2 shows a general view of the instrument with a protruding and turned bracket.

The instruments will be produced in several modifications:

DPR4-01 -- intended for the measurement of pressure or level, with a built-in master for electrical proportional or isodromic control, with a 100-percent proportionality zone, and with one emergency signal device;

DPR4-02 -- intended for the measurement of flow, with a built-in master for electrical proportional or isodromic control, with a 100-percent proportionality zone and with one emergency signal device;

DPR4-03 -- for the measurement of pressure or level, with a position-type, single-contact control device and with a built-in device for the remote-control transmission of readings;

DPR4-04 -- for the measurement of flow, with a position-type, single-contact control device and with a built-in device for remote-control transmission of readings;

DPR4-05 -- for the measurement of pressure or level, with a built-in master for electrical proportional or isodromic control, with a 100-percent proportionality zone and with a built-in device for remote-control transmission of readings;

DPR4-06 -- for the measurement of flow, with a built-in master for electrical proportional or isodromic control, with a 100-percent proportionality zone and with a built-in device for remote-control transmission of readings;

DPR4-07 -- for the measurement of pressure or level, with a built-in master for electrical proportionality zone, with one emergency signal device and with a built-in device for remote-control transmission of readings;

DPR4-08 -- for the measurement of flow, with a built-in master for the electrical proportional or isodromic control, with a 100-percent proportionality zone, with one emergency signal device, and with a built-in device for the remote-control transmission of readings;

DPR4-09 -- for the measurement of pressure or level, with a position-type two-contact control device;

DPR4-10 -- for the measurement of flow, with a position-type, two contact control device;

DPR4-11 -- for measurement of pressure or level, with a built-in master for electrical or isodromic control, with a 100-percent proportionality zone and with two emergency signal devices;

DPR4-12 -- for measurement of flow, with a built-in master for electrical proportional or isodromic control, with a 100-percent proportionality zone and with two emergency signal devices;

DPR4-13 -- for measurement of pressure or level, with a position-type, two contact control, and with a built-in device for remote-control transmission of readings;

DPR4-14 -- for measurement of flow, with a two-position control and with a built-in device for remote-control transmission of readings;

DPR4-15 -- for measurement of pressure or level, with a position-type three-contact control device;

DPR4-16 -- for measurement of flow, with a position-type, three contact control device.

Basic technical characteristics of instruments of DPR4 type

Basic error in %	± 0.25
Variation in %, nor higher than	± 0.25
Threshold of pickup in %	± 0.1
Error of operation of contacts of the position-type control device in %, not higher than	± 0.5
Over-all dimensions in mm	204X190X405

Feeding of the power system of the instruments is accomplished by an alternating current of 127 volts and a frequency of 50 cycles per second. By varying the voltage of the feed by ±10 percent and the frequency by ±5 percent from the nominal value, the error of the instruments does not exceed the basic error.

Automatic reading, self-recording and control miniature electronic secondary instruments of DSM2 and DSMR2 type with a differential-transformer system, with a chart tape 100 mm wide.

Instruments of DSM2 and DSMR2 type (Fig. 3) are intended for the measurement of pressure, vacuum, flow, level, and other magnitudes. They will be produced in a set with a corresponding pickup and different additional devices, for example:

- (a) with an electrical position-type control device;
- (b) rheostat master for electrical proportional and isodromic control, in a set with control fixtures and
- (c) with a device for the remote-control transmission of readings.

The basic error of measurement and recording amounts to -- 1 percent of the region of measurement, threshold of response 0.2 percent, time of passage with carriage and indicator and pen of the entire length of the scale can have three values: 1, 2.5, and 6 seconds. The speed of movement of the chart tape can be 20, 60 and 180 millimeters per hour.

Feeding of the measurement system is accomplished from a IPS-113 stabilized source of direct current. Feeding of the power system of the instruments -- alternating current of 127 volts and frequency of 50 cycles per second through a separating transformer. The power consumed is 50 watts. The over-all dimensions are 186 X 186 X 440 millimeters.

PSM2 and PSMR2 automatic indicating self-recording and control miniature electronic potentiometers and MSM2 and MSMR2 bridges with a chart tape 100 millimeters wide.

The potentiometers are intended for measurement, recording, and control of temperature, in a set with thermocouples, radiation pyrometers, and pickups of electromotive force, while the bridges are in a set with the resistance thermometers (Fig. 4). All these instruments can have the following additional devices:

- (a) electrical position-type control device;
- (b) rheostat master for electrical proportional and isodromic control, in a set with control fixtures;
- (c) device for remote-control transmission of readings.

The basic error of measurement and recording amounts to ± 1 percent of the field of measurement, the threshold of sensitivity 0.2 percent. The time of passage of the carriage with indicator and pen of the entire length of the scale can have three values: 1, 2.5, and 6 seconds. The speed of movement of the chart tape can be 20, 60, and 180 millimeters per hour.

Feeding of the measurement system of the potentiometers is accomplished from a ISP-113 stabilized source of direct current, while feeding of the bridges -- from the

winding of the power transformer of the amplifier of 6.3 volts. Feeding of the power system of the instruments is accomplished through a separating transformer, with alternating current of 127 volts and a frequency of 50 cycles per second. The power consumed is 50 watts; the over-all dimensions are 186 X 186 X 440 millimeters.

Small-size automatic indicating self-recording and control instruments with a differential-transformer system, multipoint.

The instruments (Fig. 5) with 2, 3, 6 and 12 points, with a differential-transformer measuring system and a recording on a chart tape 160 millimeters wide are intended for measurement and control of the following magnitudes:

- (a) difference in pressure (gradient);
- (b) flow (liquid, steam, gas);
- (c) excess pressure;
- (d) vacuum;
- (e) other magnitudes, for the measurement of which,

differential-transformer pickups are utilized.

The instruments with two points of measurement are intended for operation with level pickups; instruments with 3 and 6 points -- for operation with flow pickups, and instruments with 2 and 12 points -- for operation with pickups of pressure and vacuum.

The instruments operate in a set with pickups which, by means of a multi-point switch, are successively connected to the electrical measuring system. The pickups are mutually interchangeable.

The instruments can have a three-position control device for controlling one point and a signal device for signalling all the points (without blocking the signal and with blocking the signal).

Basic technical characteristics

Basic error of the readings in % from working course of pickup plunger:

- (a) for instruments without an air gap in the plunger of the induction coil ±0.5
- (b) for instruments with an air gap in the plunger of the induction coil ±1.0

Error in the recording in % of the working course of the pickup plunger ±1.2

Variation in readings in % of the working course of the pickup plunger:

- (a) for plunger course from 0 to 2 mm and from 0 to 5 mm 1.0

(b) for plunger course from 0 to 7 mm	0.5
Threshold of pickup in %	0.2
Error in operation of signal contacts in %	1.0
Time of run of carriage over entire scale in seconds	2, 5 and 8
Speed of movement of chart tape in mm/hour	20; 40; 60; 80; 120; 180; 240; 360; 480; and 720
Cycles of printing in seconds	3, 2; 6, 4; and 12, 8
Power consumed in watts	60
Over-all dimensions in mm	330X287X445
Weight in kg	20

The last of the above-mentioned instruments will be produced by the L'vov Council of National Economy; all the remaining -- by the Council of National Economy of the Armenian SSR.

2. The ITS-1 Instrument (for the Cable Industry)

Following is a translation of an article by V. P. Zav'yalov in Byulleten' Tekhniko-Ekonomicheskoy Informatsii (Bulletin of Technical-Economic Information), No. 2, February 1960, pages 33-34; CSO: 2900-N/11 (26).

The Scientific Research Institute of the Cable Industry (SCICI) of the State Committee of the Council of Ministers USSR for Automation and Machinebuilding developed the ITS-1 instrument in 1958. (The instrument was developed under the leadership of engineer V. G. Blokhin.) It is intended for the measurement of the thickness of lead sheathing applied on a cable in order to eliminate eccentricity (difference in wall) obtained during the spewing process.

With proper graduation, it can also be used for the measurement of the thickness of any electric conducting material by the contact method.

The ITS-1 instrument makes it possible to measure periodically the common given thickness of the lead sheathing of the cable along its entire length, to detect a difference in the wall of the sheathing without disturbing its integrity and to make prompt adjustment of the press, thereby preventing rejects. Besides this, when the given instrument is used, errors are prevented which are unavoidable during measurement.

Technical characteristics of the instrument

Measurable thickness of the lead sheathing of the cable	0.1 to 3.5 mm
Maximum error of measurement	+3%
Power consumed	100 watts
Over-all dimensions (length x width x height)	420X270X510 mm
Weight	40 kg
Magnitude of current passing during the measurement through the lead sheathing	20 ampere
Voltage at the contacts of the pickup	2.5 volts
Value of each graduation division on the scale	0.01 mm

3. Small-Size Impact-Resistant, Direct-Current Panel Instruments

Following is a translation of an article by S. I. Yur'yeva in Byulleten' Tekhniko-Ekonomicheskoy Informatsii (Bulletin of Technical-Economic Information), No. 2, February 1960, pages 38-39; CSO: 2900-N/11 (27).7

In 1959, the "Vibrator" plant developed and initiated production of small-size, panel, impact-resistant direct-current ammeters and voltmeters of the M145 type which are resistant against impacts of high intensity and are intended for operation at the temperature of the surrounding air from -40 to $+60^{\circ}$ and in a relative humidity up to 98 percent, under conditions of vibration, jolting, and slopes up to 45° . Thus, they can be utilized for the measurement of direct current in any installations under particularly heavy conditions of operation.

The instruments are issued in round, metallic, air-tight bodies with a square cast cover plate. The weight of the instruments is 0.45 kilogram; the over-all dimensions are 85 X 85 X 90 millimeters, class 2.5.

The measuring instrument has an intra-frame magnet (see illustration) in the form of a cylinder, situated within the work frame and placed within a yoke of soft iron. In order to equalize the field in the work gap, pole straps are mounted on the magnet. Such a construction makes possible maximum utilization of the magnetic flux; moreover, the influence of external magnetic fields is reduced to a minimum and the consumption of magnetic materials is reduced considerably.

A characteristic peculiarity of this construction is the fact that the parts of the measuring instrument are secured not on the base, as is customary, but on a metallic membrane which is connected with the body, not rigidly, but by means of a rubber ring. Such an attachment assures shock absorption by the measuring instrument of high-intensity impacts.

The instruments have no corrector; the stability of the zero position of the needle is assured by the high mechanical qualities of the springs made from BrB2 bronze.

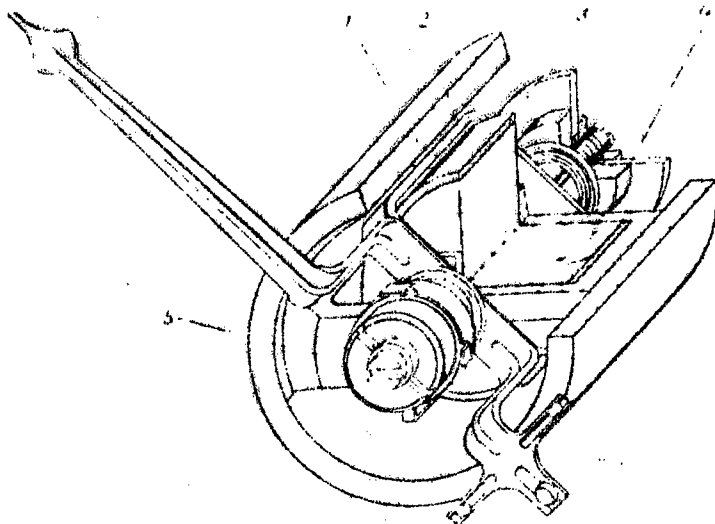

Measuring mechanism of type M145
instrument:

1 -- closing yoke; 2 -- loop; 3 -- pole
straps; 4 -- magnet; 5 -- clamp

Mechanical strength of the instrument is attained not only by the general shock absorption by the measuring instrument, but also by shock absorption by the movable portion in the supports: the design of the mandrel of the step bearing assures spring shock absorption. The parts of the movable portion are made of AMG alloy which has a high rigidity and small weight. Because of these characteristics, the instrument has impact resistance and withstands prolonged vibration within the range of frequencies of 3.3 to 33 cycles per second for an acceleration of 10 meters/square second.

In regard to the operational and technical characteristics, instruments of the type M145 are not inferior to similar instruments of foreign firms and have a much higher mechanical strength.

The basic technical characteristics of the instruments are listed in the table.

The ammeters are made for connection to shunts by wires with natural resistance of 0.035 to 0.28 ohms.

Table

Name of Instrument	Limit of Measurement	Connection of Instrument	Resistance of Instrument
Ammeters	5. 10. 20. 30. 50. 75. 100. 150. 200. 300. 500. 750. 1000. amperes	With external shunt of 75 millivolts, type 75ShS	
Voltmeters	7.5 15. 30. 50 150. 250. 350. and 450. volts	Directly	3000, 5000, 10,000, 20,000, 50,000, 100,000, 150,000 ohms

4. Domestically Produced Magnetolectric Oscillographs¹

Following is a translation of an article by Ye. S. Borisevich in Priborostroyeniye (Industrial Building), No. 2, February 1960, pages 24-29; CSO: 2900-N/11 (28).⁷

All possible self-recording instruments for continuous or selective recording of different processes are widely used in modern experimental investigations and technical measurements. Among these instruments, a special place is occupied by magnetolectric oscillographs which accomplish the recording on a uniformly moving phototape by means of a light ray.

Among the important advantages of magnetolectric oscillographs is the high sensitivity of their measuring devices (mirror galvanometers), the possibility of recording within a wide range of frequencies (from fractions to thousands of cycles per second), and also the possibility of simultaneous recording of many processes on one tape, which makes it possible to study and compare their development with time. The accuracy of the recordings obtained on oscillographs reaches one percent. Magnetolectric oscillographs are relatively simple to service and are convenient for use under laboratory as well as industrial conditions.

Oscillographs are used widely in many fields of science and engineering for recording different magnitudes which have been converted into electrical ones.

In the Soviet Union, the development of magnetolectric oscillographs was started in the Thirties, almost at the same time in several scientific organizations /1/, /2/, but, unfortunately, it was interrupted by the war and was only resumed in 1945-1947 /3/ - /5/.

During subsequent years, considerable progress was attained in the field of oscillograph production. Soviet scientists and engineers made a substantial contribution to the perfection of designs and development of a procedure for calculating the basic elements of magnetolectric oscillographs /6/ -- /12/.

1. The paper corresponds essentially to the reports which were read by the author at the first scientific-technical conference on magnetolectric oscillographs, which are held in Leningrad in March 1958 and at the seminar on vibration engineering in Moscow in February 1959.

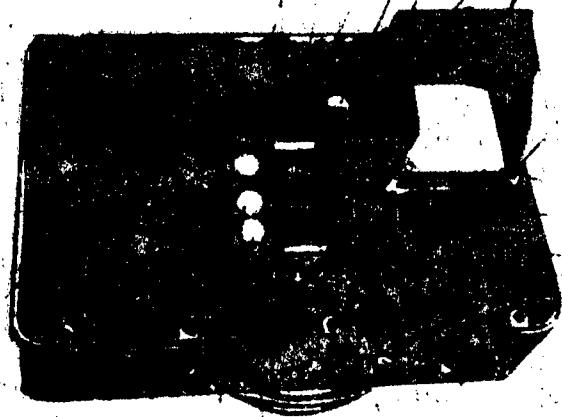

Fig. 1. Eight-channel oscillograph MPO-2;

- 1 -- terminals for connecting the pickups; 2--galvenometer breaker;
- 3--wattmeter terminals; 4--control levers; 5--marker break; 6--starting button for film; 7-- terminals of remote-control stat; 8--voltmeter;
- 9--rheostat; 10-11--speed change-over switches; 12--control of scanning speed; 13--cover of galvenometer block; 14--dull screen; 15--cover; 16--illuminator; 17--controls of slit diaphragms;
- 18--electric motor breaker; 19--charging cassette; 20--receiving cassette; 21--indicator of reserve film; 22--control of frame length; 23--contact control;
- 24 --control terminal; 25--ventilation grate.

Universal Oscillographs

Table 1 gives brief technical characteristics of universal magnetolectric oscillographs developed and produced in the USSR.

In accordance with the control figures of the Seven-Year Plan and the recommendations of the First

Table 1

Technical characteristics of universal magnetoelectric
oscillographs produced in the USSR

Type of Oscillograph	Galvanometers		Length of Optical Indicator	Type of Cassette	Phototape		
	Number	Type			Width in cm	Length in cm	Speed in cm/sec
MFO-2*	8	Loop	250	Tape	3.5	5	From 0.1 to 500
K-12-21*	12	Frame	300	Tape	10	20	0.3-1.2-6-25
K-20-21	20	Frame	300	Tape	20	35	0.1-0.25-2.5- -10-100-250
12-OS-2	12	Frame	268	Tape	12	25	0.5-2.5-5.0-25-90
OT-24	24	Frame	300	Tape	20	40	From 0.5 to 100
POB-14M **	14	Frame	300	<u>Tape</u> <u>Drum</u>	12	<u>12</u> <u>0.6</u>	<u>0.25-1-4-16-64-250</u> <u>50-200-800</u>
POB-12M	12	Frame	420	<u>Tape</u> <u>Drum</u>	12	<u>12</u> <u>0.6</u>	<u>From 0.03 to 150</u> <u>From 0.16 to 800</u>
POB-9	9	Frame	250	<u>Tape</u> <u>Drum</u>	6	<u>12</u> <u>0.3</u>	<u>From 0.25 to 80</u> <u>From 2.5 to 800</u>

* Oscillographs produced in large series.

** POB-14M oscillograph produced by the Kishinev plant under index N-700.

/Table continued on next page/

Table 1 continued from page 137

Time Marking in cycles per second	Visual Observation	Source of feed		Weight in kg	Remarks
		"	"		
500	With mechanical scanning	≈24 ~127 ~220	4 0.8	33	-
1-10	No	≈27	5 10	12	Has electric heater
0.1-1-10-100	With mechanical scanning	≈27	9 20	27	The same
10	No	≈27	3.5 9.5	16	" "
100	Without scanning	≈24	5	37	-
10-200	With mechanical scanning	≈24	3 6	18	Has rectifier and electric heater
10-200	With mechanical scanning	≈24	3	16	Has rectifier and feeding from the network
200	The same	≈24	2	9	The same

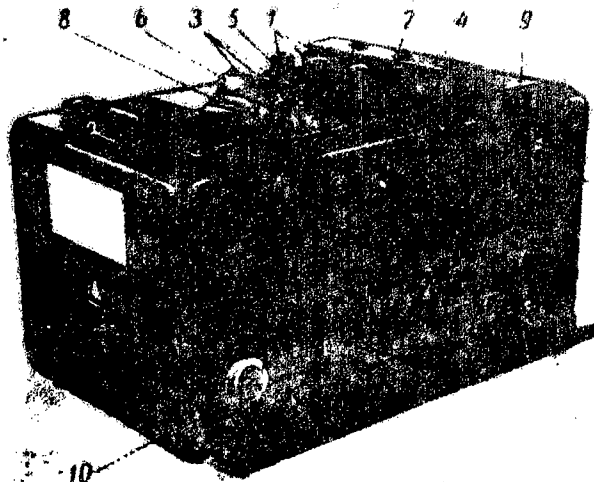

Fig. 2. K-12-21 twelve-channel oscillograph.

1--handles for controlling the incandescence of the tubes; 2--changeover switch of phototepe speed; 3--illumination lamp breakers; 4--cover of illuminators; 5--electric motor breaker; 6--signal lamp; 7--button for markings; 8--cassette attachment lock; 9--cover of the magnetic block; 10--handle of take-up reel.

Scientific-Technical Conference on Magnetoelectric Oscillographs by the State Planning Commission of the USSR, energetic measures have been taken for expanding the production of magnetoelectric oscillographs. At the present time, a new plant of electric measuring instruments of the council of national economy of the Moldavian SSR has started operations and the mass production of oscillographs; a second plant is being readied for operations. It is natural that at the first time the new enterprises will need serious assistance.

Fig. 1 shows a type MPO-2 universal oscillograph which is used most widely in our country. This instrument has been in production for several years. However, its individual parameters, for example, the characteris-

tics of the galvanometers, width of the phototape, and weight of the instrument (see Table 1) already satisfy many consumers.

Type K-12-21 /13/ oscillograph shown in Fig. 2 and the K-20-21 and 12-00-2 oscillographs are intended for tests of aviation equipment /14/. At the same time, they can be utilized with success in other investigations. All these instruments can withstand considerable overloads, have increased vibration resistance, are equipped with electric heaters and thermoregulators for operation at low temperatures, have devices for punching of lines of the recording, panels for remote control, and other additional devices related to special conditions of operation.

Type K-12-21 oscillograph is being mass produced at the instrument building plant of the Leningrad Council of National Economy. The K-20-21 oscillograph is being readied for mass production. The 12-00-2 oscillograph is being produced at the establishment of the Moscow Regional Council of National Economy in comparatively small numbers.

Type OT-24 oscillograph, shown in Fig. 3, was developed on the base of the type OS-27 seismic prospecting oscillograph. It is equipped with highly sensitive galvanometers of the type GEMZ-46 with a frequency of natural vibrations from 20 to 600 cycles per second and electromagnetic damping. A certain inconvenience is the utilization of an electromagnet instead of a permanent

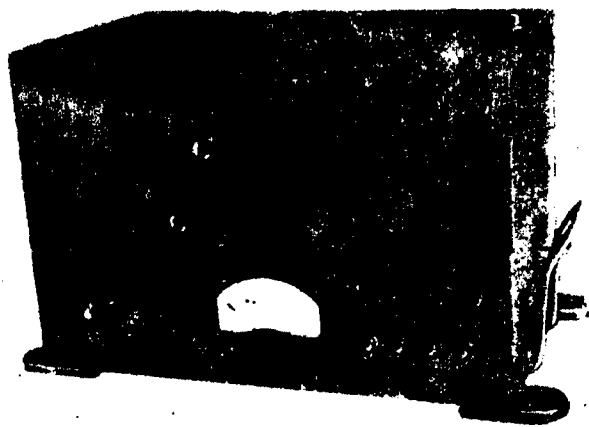

Fig. 3. OT-24 Twenty-channel oscillograph.

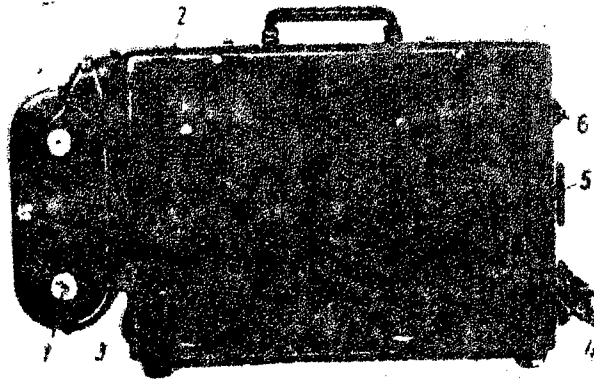

Fig. 4. POB-14M Fourteen-channel oscillograph.

1--tape cassette; 2--cover of the body; 3--folding door; 4--plug connectors for connecting the pickups; 5--plug connector for connecting the panel of remote control; 6--ears for suspending the instrument on shock absorbers.

magnet in the block of the galvanometers. The OT-24 oscillograph is a part of the installation for tensor-metric measurements. These instruments are being produced in small numbers at the plant of the Moscow Council of National Economy.

Oscillographs of the types POB-14M (see Fig. 4) as well as the POB-12 and POB-9 oscillographs were developed in the Institute of Physics of the Earth of the Acad. Sci. USSR /15/. They are provided with highly sensitive frame galvanometers of the types GB-IV and GB-III with a frequency of free vibrations from 1 to 10,000 cycles per second. All these instruments are, in addition to tape cassettes, equipped with drum cassettes for recording brief, high-frequency processes. Feeding can be accomplished from storage batteries as well as from a network of alternating current, through semiconductor rectifiers installed in the oscillographs.

The POB-12M and POB-9 oscillographs are so far being produced in small numbers by the shops of the Special Design Bureau of the Institute of the Physics of the Earth of the Acad. Sci. USSR.

The oscillograph of Type POB-14M(N-700)* is a

* The index N-700 has been assigned to the oscillograph by the Kishinev plant.

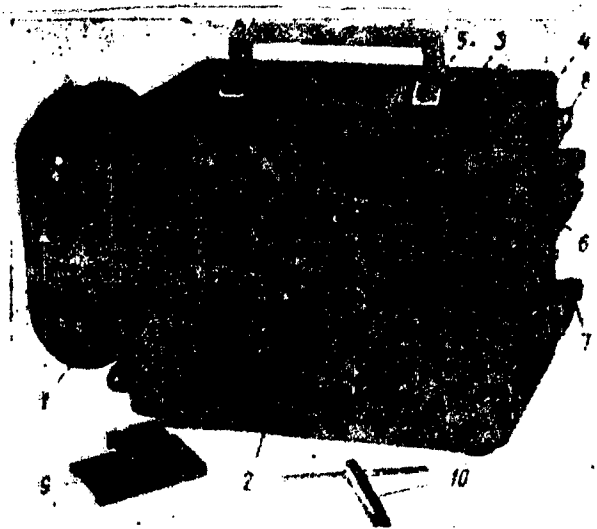

Fig. 5. Six-channel PO-6M oscill-
ograph with autonomous
electric feeding;
1 --tape cassette; 2--door of the
body; 3--filament resistor; 4--
illuminator 5--marker breaker;
6--terminals for connecting the
pickups; 7--terminals for connec-
ting the marker; 8--ears for sus-
pending the instrument on shock
absorbers; 9--frame with dull
screen for setting the optics;
10--starting switch.

modernized model of the POB-14 oscillograph and is being produced by the shops of the Moscow Mechanical Technical School and by the Kishinev plant of Electrical Measuring Instruments. It can be assumed that oscillographs of this type will have considerable use.

The set of the POB-14(N-700) oscillograph has a panel of remote control and a magazine of shunts and resistances for regulating the sensitivity and damping of the galvanometers. The instrument has a motor marker of time, which has an accuracy of ± 1 percent. The scanning of the recorded curves on the screen of visual observation is accomplished mechanically and can be regulated smoothly. The oscillograph is provided with galvanometers of type GB-IVV with improved characteristics.

On the basis of the MPO-2 oscillograph, which is]

being produced by the plant of the Leningrad Council of National Economy, an experimental specimen of a new, eight-channel universal oscillograph of the type N-101 was developed and produced in 1958. In this instrument, the recording can be accomplished on a motion picture film as well as on photopaper 10 centimeters wide. The N-101 oscillograph is not listed in Table 1 because its production is not yet organized.

Special Oscillographs

Table 2 lists the technical characteristics of some special oscillographs which have been developed and are being produced in the USSR.

The N-10 and N-11 oscillographs are being produced by the plant of the Leningrad Council of National Economy. The N-10 oscillograph is essentially a simplified model of the MPO-2 oscillograph.

The K-5-22 oscillograph is being produced by the instrument building plant of the Leningrad Council of National Economy.

The oscillographs of the types OS-60, OS-24, FR-5, and EPO-5 are used for geophysical prospecting of minerals and are produced at the plant of the Moscow Municipal Council of National Economy.

The OSh-9 oscillograph is intended for scientific investigations and is produced in the shops of the Institute of Chemical Physics of the Acad. Sci. USSR.

The oscillographs of types OMS-11 and UO-12 are used for scientific geophysical investigations and are produced in the shops of the special design bureau of the Institute of the Physics of the Earth of the Acad. Sci. USSR.

The PO-6M oscillograph with autonomous electric feeding, shown in Fig. 5, was developed by the Institute of the Physics of the Earth jointly with the All-Union Institute of Agricultural Machine Building (VISKhOM) and is produced by the shops of the special design bureau of the Institute of the Physics of the Earth and by the experimental plant of the VISKhOM. In this instrument, the displacement of the phototape is accomplished by a spring driver and the electric feeding of the illuminators and of the time marker is accomplished from four dry cells of the type "Saturn" (1-KS-UZ) installed in the instrument.

The oscillograph of type STT was developed in one of the Moscow institutes and is intended specially for the registration of thermal currents.

The series of small-size oscillographs, including the MO4-56 oscillograph indicated in Table 2, was developed at

Table 2

Technical characteristics of some special-purpose oscillographs produced in the USSR

Oscillograph		Number of Galvanometers	Length of optical indicator in mm	Phototape			Time Markings in cycles per second
Type	Intended use			Width in cm	Length in m	Speed in cm/sec	
N-10	General use	4	250	3.5	5	0.1-50	
N-11	For recording failure in the electric network	8	250	3.5	5	2.5-5	
S-22	For testing aircraft equipment	5	300	6.0	8	0.1-0.5- -2.5- 12.5	No
OS-60	For seismic prospecting of minerals	60	300	40	50	20-40	100
OS-24	For seismic prospecting of minerals	24	200	20	20	20-40	100
R-5	For logging oil bore-holes	6	360	20	40		1 30
PO-5	For electric prospecting of minerals	6	565	10	25	0.25	Contact watch
Sh-9	For scientific investigations	9	250	32	15	4-40	50 100
MS-11	For scientific investigations	18	535	20	12	0.01-2.4	Contact watch
O-12	For field investigations	12	250	12	12	0.15-1.5	Contact watch
PO-6M	For field investigations	6	150	3.5	12	1-30	Contact watch
RT	For registration of thermal currents	5	600	12	10	1-15	Contact watch
q-4-56	Special small	4	125	3.5	5	0.3-20	Contact watch

/Table 2 continued on next page/

Table 2 continued from page 20

7

Visual Observation	Source of Feed		Weight in kg	Remarks
	<i>2</i>	<i>0</i>		
Without scanning	127 220		22	
No	127 220		30	
No	-27	2 6	8.5	With electric heating
Without scanning	-24	8	80	
Without scanning	-12	5	18	
Without scanning	110	100	58	
Without scanning	-6	5	24	
Without scanning	-24	15	20	Recording on the aerophototape
Without scanning	-12	2.5	25	Drum cassette is available
Without scanning	-6	1.5	17	With spring driver
No	-6	0.5	6	With spring driver and autonomous electric feeding
No	-27	3		
No	-27	1.7	3	

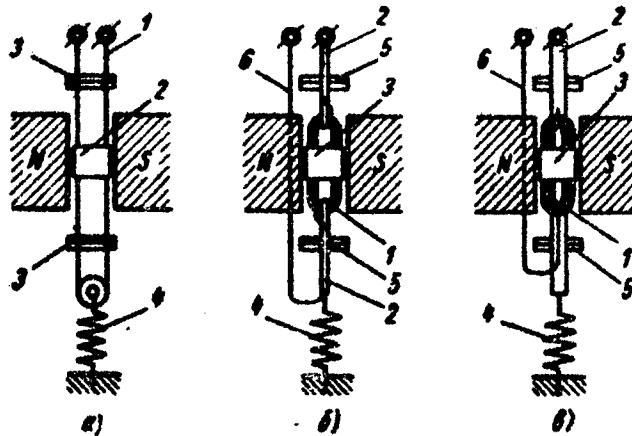

Fig. 6. Diagrams of the measuring systems of mirror galvanometers for oscillographs:

a - loop galvanometer-two-wire circuit (1-loop of fine metal thread; 2-mirror; 3-supporting thresholds; 4-draw spring); b - frame galvanometer on two spreads (1-frame of fine insulated wire; 2-upper and lower spreads; 3-mirror; 4-draw spring; 5-supporting thresholds; 6-current conductor); c-high frequency frame galvanometer on a continuous spread (1-frame of fine insulated wire; 2-continuous metallic spread; 3-mirror; 4-draw spring; 5-supporting thresholds; 6-current conductor).

one of the establishments of the Leningrad Council of National Economy.

The work of developing small-size oscillographs suitable for installation directly in the test object is being carried out in the Institute of the Physics of the Earth of the Acad. Sci. USSR and in additional organizations.

Galvanometers for Oscillographs

The measuring device in a magnetolectric oscillograph is, as is known, a mirror galvanometer /2/, /6/--/12/. The types of galvanometers and their parameters make an imprint on the entire construction of the oscillograph and predetermine its operational possibilities.

At the present time, oscillographs use galvanometers of two basic types: loop galvanometers or two-wire circuits and frame galvanometers. These types of galvanometers

differ essentially in their design, procedure of calculation, and basic parameters.

Fig. 6 shows schematically the measuring systems of modern galvanometers for oscillographs.

In the magnet gap of a frame galvanometer is not a loop but a multifork frame supported on two spreads which operate by torsion. Because of this, it becomes possible to produce galvanometers for oscillographs with a period of natural vibrations up to one second and with a correspondingly high sensitivity, which makes it possible to record on oscillographs signals of some pickups (vibrometers, tensometers, thermocouples, etc.) without the use of amplifiers. Frame galvanometers with a frequency of natural vibrations of 20 cycles per second and lower have integrating characteristics /12/.

For recording high frequencies, frame galvanometers with a continuous spread /9/ are used along with two-wire circuits.

In a frame galvanometer, it is possible, without changing its sensitivity, to secure the mirror in any place of the frame and also along with the frame, on the spread. This made it possible to group the galvanometers in a common magnetic system and to reduce their deminsions substantially. As a result, it became possible to develop highly portable multichannel oscillographs /15/, /14/.

Table 3 lists the technical characteristics of galvanometers for oscillographs produced in the USSR.

It is seen from Tables 1 and 3 that Soviet oscillographs essentially use frame galvanometers. The utilization of frame galvanometers, grouped in a common system, instead of loop galvanometers with individual magnetic systems, has made it possible -- as is seen from Table 1 -- to reduce the weight of the oscillograph per channel from four to 1--1.5 kilograms.

It is necessary to point out that domestically produced galvanometers for oscillographs are not inferior to galvanometers of foreign firms, in regard to their design data and technical characteristics. (Winterling, K. K. High-frequency galvanometers. III. Mirror galvanometers with a rotatable frame. Archives of Technical Measurements (ATM), 721, 19 April 1957.)

Research work on the improvement of galvanometers and their technical characteristics is continuing.

Oscillographs with a Visible Recording

An inconvenience of magnetoelectric oscillographs which perform the recording on a phototape is the inability

Table 3

Technical characteristics of some galvanometers for oscilligraphs produced in the USSR

Type of Oscillograph	MPO-2 and N-O				K-21	
	MOV-2 loop		MOV-2 loop		NU-84 frame	
Type of galvanometer	Current constant in a. m/mm.	Resistance in ohms	Current constant in a. m/mm.	Resistance in ohms	Current Constant in a. m/mm.	Resistance in ohms
Frequency of free vibrations (cycles per second)						
30						
60						
120						
150						
200			$1 \cdot 10^{-2}$	55		
300			$1 \cdot 10^{-2}$	55		
400						
800					$1.5 \cdot 10^{-2}$	10
1500	$2 \cdot 10^{-2}$	11				
2000	$7 \cdot 10^{-2}$	6			$5.5 \cdot 10^{-2}$	25
3000	$2 \cdot 10^{-2}$	6				
5000	$1 \cdot 10^{-2}$	6			$1.5 \cdot 10^{-2}$	10
10000	$5 \cdot 10^{-2}$	1				

Table 3 continued on next page

Table 3 continued from page 247

12-OS-2		OT-24		POB-9-12-14; PO-6M			
Frame		GEMZ-46 frame		GB-IV-A frame		GB-IV-B frame	
Current constant in a. m/mm.	Resistance in ohms	Current constant in a. m/mm.	Resistance in ohms	Current constant in a. m/mm.	Resistance in ohms	Current constant in a. m/mm.	Resistance in ohms
		$2.5 \cdot 10^{-2}$	36*	$5 \cdot 10^{-2}$	13*	$1.3 \cdot 10^{-2}$	170*
$1.5 \cdot 10^{-2}$	20.1*	$1.2 \cdot 10^{-2}$	45*	$2 \cdot 10^{-2}$	13*	$1 \cdot 10^{-2}$	170*
$3 \cdot 10^{-2}$	10*			$7.5 \cdot 10^{-2}$	10*	$1 \cdot 10^{-2}$	170*
$6 \cdot 10^{-2}$	55*	$4.5 \cdot 10^{-2}$	56*				
		$1 \cdot 10^{-2}$	56*				
$4.3 \cdot 10^{-2}$	18*	$4.2 \cdot 10^{-2}$	56*	$3 \cdot 10^{-2}$	10	$2.5 \cdot 10^{-2}$	165*
$9.3 \cdot 10^{-2}$	10*			$1.5 \cdot 10^{-2}$	8		
$1.5 \cdot 10^{-2}$	10*	$7 \cdot 10^{-2}$	56*	$5 \cdot 10^{-2}$	8		
				$2.5 \cdot 10^{-2}$	8		
				$1 \cdot 10^{-2}$	8		
				$4 \cdot 10^{-2}$	8		

Table 3 continued on next page

Table 3 continued from page 257

POB-9-12-14; PO-6M		NO		Remarks
GB-IV-V frame		Frame		
Current constant in a. m/mm.	Resist-ance in ohms	Current constant in a. m/mm.	Resist-ance in ohms	
2 · 10 ⁻²	5*	1 · 0 ⁻²	100	1. Frequencies of free vibrations of some galvanometer are equalized. 2. Current constant of all the galvanometers is reduced to the meter. 3. Galvanometers marked with a star have electromagnetic damping. 4. Galvanometers of the types GEMZ-46 and GB-IV are interchangeable.
1 · 10 ⁻²	5*			
3 · 10 ⁻²	52*	6 · 1 · 10 ⁻²	10*	
2,5 · 10 ⁻²	52*	0,5 · 10 ⁻²	10	
4 · 10 ⁻²	32			
2,5 · 10 ⁻²	15			
1,5 · 10 ⁻²	15			
5 · 10 ⁻²	15			
2 · 10 ⁻²	11			



Fig. 7. POB-14 oscillograph with an electrographic attachment: 1--oscillograph; 2--electrographic attachment.

to obtain at once a visible recording of the processes under investigation and the need to process the tape in a dark building with liquid chemical reagents.

The development of methods of visible recording accomplished by a light ray by means of highly sensitive mirror galvanometers give the magnetolectric oscillographs a new valuable quality, which will expand still more the field of their application. In particular, such oscillographs should, in the corresponding design development, be simpler and more universal than modern pen-writing potentiometers.

At the given time, three of the most promising methods of obtaining a visible recording on an oscillograph have been determined.

The first method is based on the utilization of bromine-rhodon "daytime" photopaper sensitive to ultraviolet rays and slightly sensitive to the spectrum of visible light /16/. As a light source in the given case, use is made of a mercury lamp of high pressure and the corresponding optics. The phototape comes out of the oscillograph with a visible recording and can at once be subjected to analysis. Daytime light and the light of the electrical lamp of incandescence cause a rather slow darkening of the photopaper. In case of the need of prolonged storage of the recording, the phototape is treated with a fixing composition. Industry has mastered the production of bromine-rhodon photopaper of the type U-F, and at the present time the plant of the Leningrad Council of National Economy has already developed an experimental specimen of an oscillograph with a visible recording based on the utilization of such paper.]

A shortcoming of this method of recording is the need of utilizing a mercury lamp of high pressure, which requires powerful sources of feeding.

The second method is based on the principles of electrography. In this case, the recording is accomplished on semiconducting paper and comes out from the instrument developed and ready for reading.

As a result of the joint work of the Institute of the Physics of the Earth of the Acad. Sci. USSR and the Scientific Research Institute of Electrography (Council of National Economy of the Lithuanian SSR), the EPO-1 electrographic attachment has been designed for the mass-produced oscillograph of the type POB-14M(N-700). The POB-14 oscillograph with the electrographic attachment is shown in Fig. 7. The attachment is installed in the place of the cassette of the oscillograph and is automatically connected to the mechanism and the electrical circuit of the instrument.

The EPO-1 electrographic attachment makes it possible to register at the same time seven different processes with a frequency of up to 50 cycles per second and an amplitude of 25 millimeters. Recording is accomplished on a semiconducting paper tape 120 millimeters wide. When the attachment is used, galvanometers of the type GB-III with an enlarged mirror are installed in the oscillograph. The over-all dimensions of the attachment are 120 x 220 x 240 millimeters; the weight is not over 3.4 kilograms.

In 1960 the Kishinev Plant of Electrical Measuring Instruments started mass production of the EPO-1 electrographic attachments for the POB-14M(N-700) oscillographs produced by this plant.

The third method which makes it possible to obtain at once a visible recording is based on the treatment of the phototape directly in the instrument with a special developing and fixing paste. It is not impossible that this method, when perfected, will be sufficiently effective and economical for utilization in oscillography.

Conclusion

As has been shown, over 20 different types of magneto-electric oscillographs have been developed and are being produced in the Soviet Union. As a whole, they are not inferior to modern models of oscillographs produced in foreign countries.

Along with the existence of different models of multi-channel portable oscillographs in our country, stationary laboratory oscillographs are, unfortunately, not being produced so far. Such instruments, having a high accuracy, and

provided with galvanometers of a wide variety and control devices adapted for instantaneous frame and continuous recording with maximum operating conveniences, are very useful in accurate laboratory investigations.

A very pressing problem is the organization of the production of projection oscillographs for educational purposes.

In the registration of episodic phenomena, the time of occurrence of which cannot be foretold, for example, earthquakes, accidents, etc., it is expedient to have a combination of an oscillograph which writes with a light ray with a registration instrument which has a memory: magnetic, luminescent, etc. Such instruments are already available and work in this direction is continuing.

Recently new ideas have been advanced for the improvement of magnetolectric oscillographs. Different automatic devices which control the amplitude of the recording, the incandescence of the lamp, the speed of displacement of the phototape, the feed of different signals, etc., are being installed in the oscillographs. Radioelectronics are being used more and more in magnetolectric oscillographs/7/.

The development of oscillograph building in the Soviet Union requires intelligent unification of the design of oscillographs. The idea is being advanced for the development (with consideration of accumulated experience) of a normal series of universal portable oscillographs. In design they should have a single construction, should be assembled from standard units, and should differ only in the number of channels, width of paper, and transverse dimensions.

Widening of the sphere of application of oscillographs requires intensification of the work for the development of machines for the automatic analysis of recordings. Highly promising from the point of view of convenience of analysis is the accomplishment of a multi-channel recording on a magnetic tape with a parallel or following recording on a phototape /17/.

In the light of this presentation, the coordination of work of oscillograph construction and of apparatus for the analysis of oscillographic recordings assumes important significance. These functions are imposed on the All-Union Scientific Research Institute of the Construction of Electrical Instruments (VNIIEP).

Bibliography

1. Gun, L. A. et al. Soviet two-wire oscillographs. Elektrichestvo /Electricity/, No. 7, 1939.
2. Bur'yanov B. P. Magnetolectric oscillograph. Ener-

- goizdat, 1952.
3. Shvedchiko L. K. Twenty-channel seismic station SS-12-46. Razvedkanedr [Prospecting for Minerals], No. 2, 1947.
 4. Borisevich Ye. S. Nine two-wire oscillograph UO-1. Elektrichestvo, No. 4, 1947.
 5. Damskiy A. M. and Seliber B. A. Universal oscillograph of the type MPO-2. Vestnik elektropromyshlennosti [Herald of the Electrical Industry], No. 7, 1948.
 6. Ponomarev N. N. Theory, calculation, and design of electrical measuring instruments. Energoizdat, 1943.
 7. Kharchenko R. R. Correction of frequency characteristics of a vibration oscillograph. Elektrichestvo No. 4, 1954.
 8. Arutyunov V. O. Calculation and design of electrical measuring instruments. Gosenergoizdat, 1956.
 9. Borisevich Ye. S. High-frequency frame galvanometers. Izvestiya AN SSSR, ser. geofiz. [News of Acad. Sci. USSR., geophysics series], No. 4, 1957.
 10. Seliber B. A. Magnetoinduction damping of high-frequency oscillographic vibrators. Izmeritel'naya tekhnika [Measurement Engineering], No. 4, 1958.
 11. Lebedev G. P. and Loschchinina N. I. Frame vibrators for the MOP-2 oscillograph. Vestnik elektropromyshlennosti, No. 7, 1958.
 12. Biber L. A. and El'kind Yu. M. Magnetolectric oscillographs with frame galvanometers. Elektrichestvo, No. 10, 1958.
 13. Nikulin V. P. and Dmitriyev V. A. Twenty two-wire circuit oscillograph K-12-21. Publishing House of VINITI, Pribery i stendy (Instruments and stands), 1956.
 14. Nikulin V. P. Magnetolectric oscillographs used in investigations and tests of aviation equipment. Priborostroyeniye [Instrument Building], No. 12, 1958.
 15. Borisevich Ye. S. Portable magnetolectric oscillographs. Priborostroyeniye, No. 10, 1956.
 16. Lebedev G. P. and Rosenpleter E. N. Inertia oscillographs with a recording on daylight paper. VNIIEP, Information-technical collection No. 16(145), 1958.
 17. Melamud A. Ya. et al. Station of intermediate magnetic recording of seismic vibrations. Izvestiya AN SSSR, ser. geofiz., No. 2, 1959.

5. Electrical Measuring Instruments for Infra-Low Frequency Circuits

Following is a translation of an article by P. B. Usatin in Byulleten Tekhniko-Ekonomicheskoy Informatsii (Bulletin of Technical-Economic Information), No. 2, February 1960, pages 35-38; CSO: 2900-N/11 (29).7

The "Vibrator" plant of the Leningrad Council of National Economy has developed a series of panel-type electrical measuring instruments for alternating-current networks of infra-low frequency (0.15-1.5 cycles per second). The instruments are intended for controlling the operation of an installation for electromagnetic mixing of steel in steel smelting furnaces. The use of electromagnetic mixing accelerates the smelting process and improves considerably the quality of the smelted steel.

The main sections of the mixing installation are a plane stator situated under the furnace bottom and two alternating-current generators of infra-low frequency, which generate a two-phase system of voltages with a 90°-angle of displacement of the phases. When the winding of the stator is fed with a two-phase current, a running magnetic field is created which drags with it the metal in the smelting furnace.

During the operation of the installation and adjustment of the process, it is necessary to control the following parameters: voltage and current of load in each of the phases; current in the excitation winding and in the auxiliary devices of each of the generators; active power consumed by the plane stator (in both phases); frequency of the network.

The basic technical characteristics of the instruments are listed in Table 1.

The over-all dimensions, weight, length of the scale, and the damping time of the instruments are listed in Table 2.

The instruments are housed in spray-protected bodies intended for embedded mounting on panels. The Tsl30 and DZl0/1 instruments have a square body which consists of a cast stile strip, steel casing, and plastic base. The Vl36 frequency meters have a profile body consisting of cast stile strip and base and steel casing.

The ammeters and voltmeters have a single-standard measuring mechanism of the electromagnetic system and a valve rectifier on germanium diodes. In the development of the instruments, the main attention was directed to assure the necessary damping of the vibration of the movable portion

Table 1

Name of Instrument	Type	Class of Accuracy	Limits of Measurement; nominal currents and voltages	Connection
Ammeter	Ts130	2.5	25 amperes 75 amperes 2.5 amperes	With external shunt 300 millivolts, 20 amperes. The same for 60 amperes
Voltmeter	Ts10	2.5	250 volts	Direct
Wattmeter, two-phase	DZ10/1	2.5	1000 kw. 220 v, 2000 amperes	With external shunts, 300 millivolts, 2000 amperes and individual additional resistances of the type R1820
Frequency meter	V136	1.5	0-2 cycles/sec* 220 volts	With individual additional device of the type R1816

* Working section of the scale of the frequency meter--from 0.5 to 2 cycles per second.

Table 2

Name of instrument and type	Angle of scale, degrees	Length of scale, mm	Overall dimensions, mm	Weight, kg	Damping time, sec
Ammeter and volt-meter of type Ts130	90	135	186X186X125	3.5	1.5
Wattmeter of type DS10/1	90	135	186X186X125	3.0	4
Frequency meter of the type VI36	60	90	160X80X190	2.5	1.5
Additional device of the type R1816 to the frequency meter	-	-	150X235X100	2.5	-
Additional resistance of the type R1820 to the wattmeter	-	-	110X155X95	1.2	-
Shunt of the type 300 ShS to the ammeter and wattmeter:	-	-			
300 ShS/20 for 20 amperes	-	-	210X30X25	0.16	-
300 ShS/60 for 60 amperes	-	-	210X30X25	0.20	-
300 ShS/2000 for 2 kiloamperes	-	-	450X120X100	11.0	-

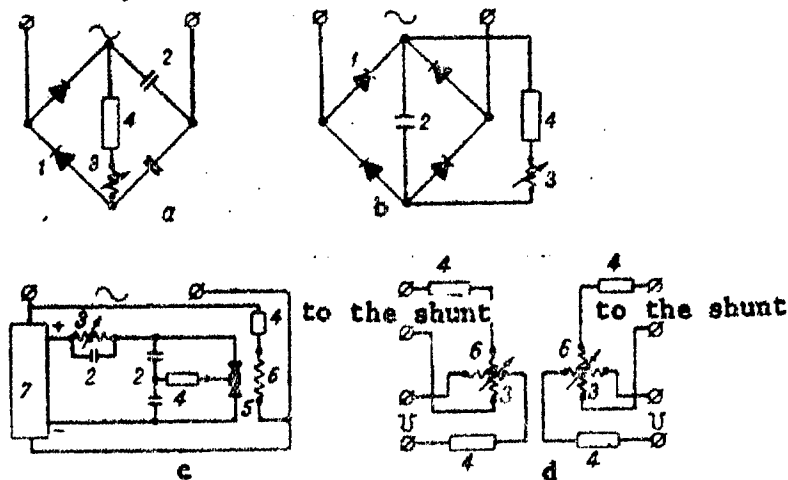

Fig. 1. Main circuits of internal connection of the instruments:

a--ammeter; b--voltmeter; c--frequency meter; d--wattmeter; 1--rectifier; 2--capacitors; 3--frames; 4--resistances; 5--polarized relay; 6--excitation winding; 7--feed source (stabilized).

under the influence of the variable rotating moment of infra-low frequency. As distinct from ordinary instruments of the rectifier (detector) system, the measuring circuit of the ammeter and voltmeter contains a filter of the low frequencies of the type RC with a time constant of the order of 10-15 seconds (Fig. 1).

In the voltmeter, the voltage being measured is rectified by a push-pull rectifier assembled in accord with a bridge circuit. A capacitor is connected at the output of the rectifier. The winding of the small frame, connected in series with a large additional resistance, is connected to the terminals of the capacitor and conducts the current which is proportional to the voltage on the capacitor.

In the ammeter which measures the current passing through the shunt, a voltage is produced thereon which is rectified by a push-pull rectifier in accordance with the circuit of doubling the voltage with two capacitors. The winding of the small frame and the additional resistance which is connected in series with it is connected to the diagonal of the rectifier bridge and conducts the current I , which is proportional to the voltage on the two capacitors

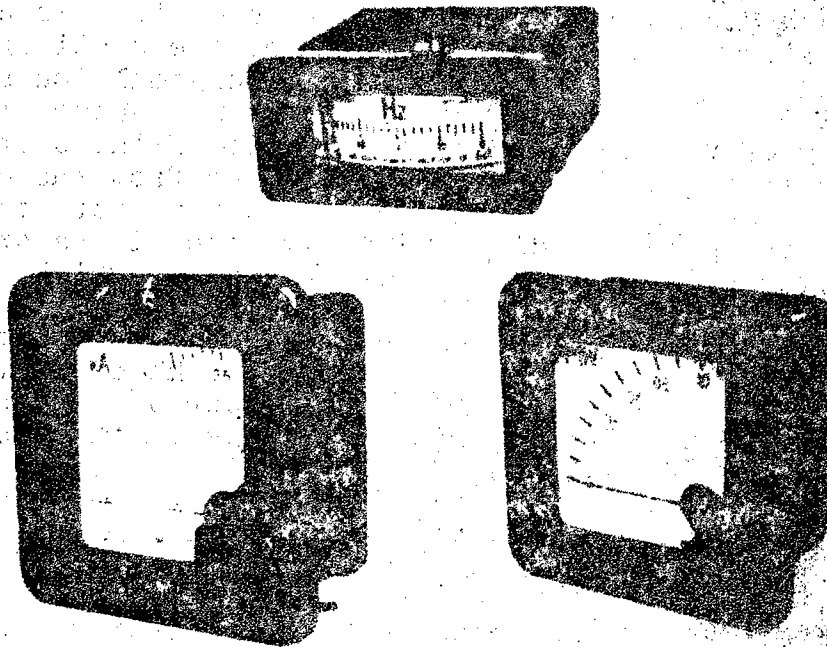

Fig. 2. Outside view of the instruments

connected in series.

The readings of the ammeter and voltmeter are accurate only for the sinusoidal form of the curve of the measured current or voltage.

The wattmeters employ a two-element measuring mechanism of the ferrodynamic system. The windings of each of the elements are connected independently to each of the phases of the two-phase power system. The rotating moments of both elements of the wattmeter are summated on the common axis of the movable portion of the instrument. As is known, the instantaneous power of the two-phase system for a uniform load of both phases does not have a variable component. For this reason, the wattmeter does not have special devices for damping the vibrations of the movable portion under the influence of a variable moment; the instruments has only magnified magnetoinduction damping.

As distinct from ordinary circuits of connecting wattmeters of industrial frequency, in the instrument DZ10/1 (see Fig. 1) the windings of the excitation coils are connected to the phase voltages of the network through additional resistances (situated in an individual body), while the circuits of the small frames are connected to the shunts which

conduct linear currents of the network. For temperature compensation, a semiconductor resistance (thermistor) is connected in series in the circuit of each of the small frames.

The frequency meters of the vibration-emulsion system have a sensitive magnetoelectric measuring mechanism, the frame winding of which conducts the current of the charge of the two capacitors which are in turn charged from the constant-voltage source and are discharged on ballast resistance. The processes of charging and discharging the capacitors are controlled by a polarized relay, the winding of which is fed by the voltage of the network being measured.

Under condition of invariability of the constant voltage of the source, the average magnitude of the current in the small frame is proportional to the measured frequency. As such a source, use is made of the voltage on the gas discharge stabilizer which is fed from the voltage of the measured network of low frequency through the rectifier. For damping the vibrations of the movable portion, the winding of the small frame is shunted by an electrolytic capacitor of great capacitance.

The readings of the frequency meter do not depend on the form of the voltage curve.

The enumerated instruments, besides their intended main application -- control of the operation of the installation of electromagnetic mixing of metal -- can find application also in other branches of industry which utilize currents of infra-low frequency.

6. Single-Phase Type VMO-35 Oil Circuit Breaker

Following is a translation of an article by I. G. Korovyakovskiy in Byulleten Tekhniko-Ekonomicheskoy Informatsii (Bulletin of Technical-Economic Information), No. 11, November 1959, pages 44-45; CSO; 2900-N/11 (30).7

The Seven-Year Plan for the Development of the National Economy provides high rates of growth in the extension of electrified railroads, using single-phase alternating current of industrial frequency. The "Urals Elektroapparat" plant has, for the first time in the USSR, developed the design of a single-phase oil circuit breaker for a voltage of 27.5 kilovolts which is intended for railroads.

In the development of the design of this breaker, it was decided to utilize the maximum number of parts and units of the breaker presently being produced by the plant. This facilitated the fulfillment of technological equipment and assured rapid adoption of production and interchangeability of parts.

The VMO-35 oil circuit breaker (see illustration) represents a single-pole apparatus for an outside installation, mounted on a common frame with an electromagnetic drive. The breaker provides two arc-suppression devices situated within a metal tank and secured at the ends of paste-filled inlets. The arc-suppression devices (chambers), installed in the breaker, make it possible to make without examination up to five cut-offs of short circuits with a maximum power of the cut-off and up to one hundred cut-offs with nominal current.

An increase in reliable and stable operation of the breaker was essentially obtained as a result of the application of a special refractory ceramic material burned on the ends of the current-conducting parts. Since the breaker is intended for installation at an open substation, then, in order to assure its normal operation under winter conditions, provision is made for electric heating in the lower section of drive tank. Heating is started when the air temperature reaches -- 25°. In order to make the breaker stable during transportation and operation, the frame of the breaker was made of minimum height. The tank is lifted and lowered by a special winch secured on the frame of the breaker.

An electromagnetic direct-current drive is provided for controlling the breaker. Drive feed can be accomplished from a network of direct as well as alternating current.

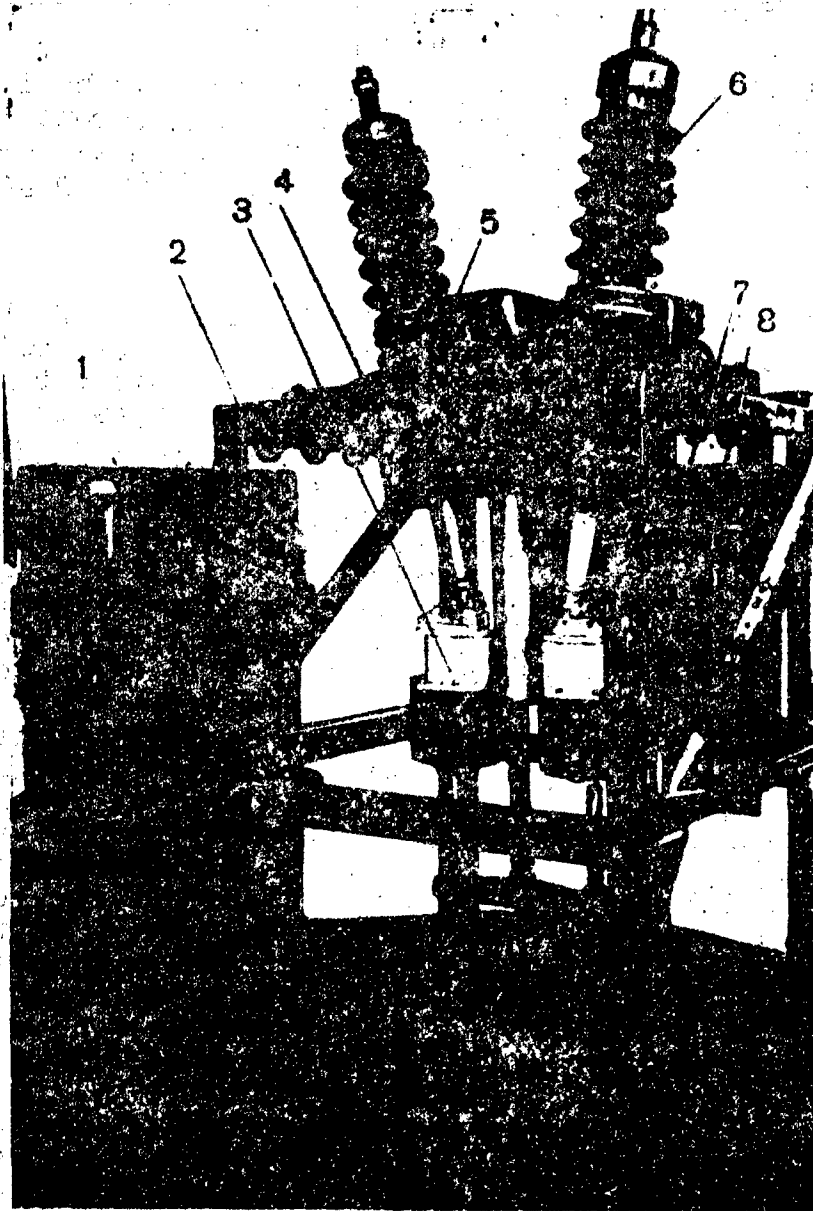

General view of VM0-35

1--breaker tank; 2--breaker frame (carcass);
 3--arc-suppression devices; 4--current
 transformers; 5--breaker cover; 6--capacitor
 inlet; 7--movable contacts; 8--electromag-
 netic drive.

When the drive is fed from an alternating-current network, the drive is connected directly to the network, but when fed from a network of alternating current, the drive is connected to the network through semiconductor rectifiers (in accordance with special circuits).

In March 1959, the experimental breaker passed successful tests at the Leningrad Branch of the All-Union Electrotechnical Institute.

After testing the breaker, its following parameters were established:

Nominal voltage.....	27.5 kilovolts
Maximum working voltage.....	29 kilovolts
Nominal current.....	1000 amperes
Nominal cut-off current.....	14.5 kiloamperes
Nominal cut-off power.....	400 megawatts
Weight of breaker.....	1200 kilograms
Weight of oil.....	270 kilograms

At the present time, the plant is producing a commercial lot of breakers which will be shipped for operation on railway transport.

7. Conference on the Utilization of Power
Semiconductor Rectifiers in Industrial
Enterprises and in Transport

Following is a translation of an article by V. A. Naydis in *Elektrichestvo* (Electricity), No. 2, February 1960 pages 89-90; CSO: 2900-N/11 (31).7

A scientific-technical conference on the utilization of semiconductor rectifiers in industrial enterprises and in transport was held in Moscow in November 1959; the conference was organized by the Moscow House of Scientific-Technical Propaganda ineni F. E. Dzerzhinsky, by the directors of the Exhibition of the Accomplishments of the National Economy of the USSR, and by the Scientific-Technical Society of Power Engineers. The conference was attended by 330 representatives of scientific organizations, design bureaus, and plants. The conference was opened by the representative of the State Committee on Automation and Machinebuilding, I. I. Dobromyslov, who dwelt on the significance of semiconductor rectifiers for the national economy of our country.

Corresponding member of the Acad. Sci. USSR, B. M. Vul, cast light in his report on the problems of the design of a germanium rectifier element. Analytical relationships have been obtained between the characteristics of the diodes and the properties of the semiconductor material (specific resistance and length of diffusion) and the dimensions of the diodes.

The report by engineer V. P. Kamenskaya dealt with the procedure of testing and determining the maximum parameters of powerful semiconductor devices.

The report by candidate of technical sciences A. A. Sakovich examines the rational fields of application of converters of different types: motor-generator, mercury, mechanical, selenium, silicon, and germanium rectifiers. Not one of the converters can occupy a dominant position and expel the remaining in all fields of engineering. It is most expedient to employ static converters: sealed mercury rectifiers and semiconductor rectifiers, which are components of converter sets.

Candidate of technical sciences A. A. Tayts delivered a substantial report on the development of power semiconductor rectifiers and sets in foreign countries.

Various reports were made by representatives of organizations engaged in the development and production of semiconductor rectifiers.

The report by candidate of technical sciences S. B. Yuditskiy covers the work of the All-Union Electrotechnical Institute imeni V. I. Lenin on the development of germanium and silicon rectifiers and rectifier sets for industry. The series of germanium rectifiers developed by the All-Union Electrotechnical Institute has been mastered by the plant of the Mordov Council of National Economy. Under development are several powerful rectifier devices for industry. The task has been set for 1960 to develop power, controlled silicon rectifiers for a current of 10 amperes and a voltage of 300 volts.

Engineer I. A. Tepman reported on the mastery of germanium and silicon rectifier devices at the plant of the Mordov Council of National Economy. The plant has mastered the production of germanium rectifiers of the type VG10, VG50, GVV200 for currents of 10, 50, and 200 amperes, back voltage up to 110-150 volts. The germanium rectifiers of the series D302-305 for a current of 1-10 amperes, back voltage up to 200 volts have been produced. Since 1960 the cost of rectifiers has dropped two to three times. An experimental germanium rectifier of the type VG500 has been produced for a current up to 500 amperes, voltage up to 150 volts; sets for electrolytic baths have been developed and for feeding the power load, and charging acid batteries.

The report by engineer A. I. Gribov dealt with the production of silicon rectifiers at the plant of the Moscow regional council of national economy. The plant has, on the basis of its own advanced technology, developed silicon rectifiers of the series PVK for a current up to 100 amperes, back voltage up to 400 volts. An experimental lot of silicon rectifiers has been produced and it has been tested in various rectifier installations. The first experimental silicon rectifiers have been produced for a current up to 600 amperes, voltage up to 300 volts with water cooling.

The report by engineer N. P. Bulavin examined the technical-economic characteristics and rational fields of application of selenium rectifiers. The technological processes have been developed for the production of selenium cells which assure an increase in current density of two to three times (up to 75 milliamperes/centimeter), back voltage up to 45-60 volts, allowable working temperature up to 130°C, service life up to 30-40 thousand hours. Other semiconductor rectifiers cannot compete with selenium rectifiers in the field of high voltages and small currents, strong currents and low voltages for repeated brief conditions and considerable overloads.

Various reports dealt with the utilization of rectifiers in industry and in transport and also the requirements

imposed upon rectifier installations.

Engineer S. M. Rubinovitch pointed out the rational fields of use of semiconductor rectifiers in nonferrous metallurgy, and he determined the basic requirements imposed upon rectifier installations. Undoubtedly, the wide adoption of semiconductors for the solution of energy capacitance problems of electrolysis gives a considerable saving for the national economy of the country.

The report by engineer A. A. Karvovskiy examines the use of semiconductor rectifiers in galvanic shops, and requirements were formulated for rectifier sets for these shops.

The development of electric locomotives with semiconductor rectifiers was dealt with in the report by engineer N. Kh. Sitnik. A six-axle electric locomotive is under design with silicon rectifiers of the type N62 and a power of 4,000 kilowatts. The installation of silicon rectifiers instead of mercury rectifiers will, besides operational advantages, assure a decrease of 20 percent of the standard power of the transformer, make its use possible for each motor and individual rectifier installation, and simplify the control system. The basic problem is the development of a reliable protection of the rectifiers.

The report by engineer P. V. Krotov examines the project of a narrow-gauge electric locomotive with silicon rectifiers with a power of 150 kilowatts and with a coupled weight of 16 tons. The electric locomotive is designed on the basis of silicon rectifiers of the series PVK for a current of 100 amperes, voltage of 300 volts. Protection is accomplished by increasing e_k of the traction transformer and rapid-acting PNB-2 fuses. Control of the speed of rotation is accomplished by connecting the traction motors to the rectifier bridges of different voltages.

The report by doctor of technical sciences A. I. Moskvitin dealt with the use of semiconductor rectifiers for the excitation of synchronous generators and motors. The most progressive is the attempt not only to replace the rotating excitation unit by a static semiconductor rectifier, but also to place it on the roll of the generator in order to eliminate sliding contact. Moreover, it is possible to make excitation windings of the machine on currents of several thousand amperes with one-two conductors in a groove and with liquid cooling. The use of wedgeless construction assures an increase in the efficiency of the machine and its overload capability with respect to heating. Circuits and designs have been developed of exciters with semiconductor rectifiers which are installed on the rotors of the machines. Development is underway of direct-current machines with the

replacement of the commutators by semiconductor rectifiers.

Candidate of technical sciences L. M. Tverdin reported on the use of semiconductor triodes in automated electric drives with mercury rectifiers which feed direct-current motors and in circuits of frequency control of asynchronous motors. The developed single-channel system of network control by multi-phase ionic converters on semiconductor triodes assures low power of control (up to 0.1 watts), constancy of steepness of the front of the trigger pulse, rapid action, small sizes and weight. Circuits of frequency converters on triodes of the type P4 with feed of motors of power up to 70 watts have been developed and investigated. A task has been set to increase the power of semiconductor triodes, which will make it possible to solve the long-ripened problem of alternating-current electric drive with frequency control.

The report by V. A. Naydis examines the utilization of power semiconductor rectifiers in the electric drive of tools and machines. A developed direct-current drive with a wide range of control of the motor with weakening of the current to 1:4 with feeding from a silicon rectifier with diodes of the series PVK on 50, 100 amperes and 300 volts should be used expeditiously in mechanisms of main motion of metal cutting tools.

Some reports dealt with the experience of development, production, and industrial operation of installations with selenium rectifiers.

The report by I. A. Salynskiy touched upon the problems of the development and investigation of devices with selenium rectifiers for welding installations. Calculations are cited of the parameters of the rectifiers and their characteristics. Descriptions are given of the types VSS-120-3 and VSS-300-2 welding installations for manual arc welding, cutting, and fusing on metal.

The report by engineer M. M. Smirnov presented the experience of the production and operation of rectifiers for installations of metal coatings and electric arc welding. It is necessary to consider as positive the experience of operation in the course of over three years of a selenium rectifier with oil cooling.

The theme of the report by engineer B. V. Strogov was the experience in the production and operation of power selenium rectifiers for installations of galvanic and anodic coatings. The lecturer considers most expedient the use of natural air cooling of selenium columns. Several types of selenium rectifiers have been produced for galvanic and anodic baths, units for starting motors, a rectifier for electric arc welding.

The conference adopted an extensive solution on problems of the development and production of semiconductor elements and sets with their utilization. The conference recognized that at the present time in the field of production of power germanium and silicon rectifiers, as well as in the improvement of selenium rectifiers, certain progress has been attained. However, the production of power semiconductor rectifiers does not assure the requirements of the national economy with respect to volume or nomenclature.

This is particularly pertinent to sets with semiconductor rectifiers. It is necessary to develop powerful semiconductor rectifiers for electrolytic installations, anodizing, production of copper, zinc, and other metals, electric drive of tools and machines, feeding of arc furnaces, excitation of synchronous machines, electric traction, etc.

Silicon rectifiers are needed for a current of up to 1000 amperes and back voltage of up to 1000 volts, controlled semiconductor rectifiers for large currents and high back voltages, dry transformers with small losses, reliable and rapid-acting protection of rectifiers.

The conference recommended to accelerate the development of State All-Union Standards on semiconductor rectifiers with a single procedure of testing and to develop a scale of basic parameters of rectifier devices.

8. Series A2 and A02 Three-Phase Induction Electric Motors

Following is a translation of an article by N. L. Marchenko in Byulleten Tekhniko-Ekonomicheskoy Informatsii (Bulletin of Technical-Economic Information), No. 11, November 1959, pages 40-43; CSO: 2900-N/11 (32).7

The existing single series A and A0 asynchronous electric motors with a power of 0.6 to 100 kilowatts does not satisfy modern requirements of national economy.

A substantial shortcoming of this series is the small number of power steps. The entire series has only 14 power steps instead of 18-20 steps in the same range.

Moreover, the single series A and A0 electric motors is, on the average, 15 percent heavier than the electric motors of corresponding power of existing series by foreign firms.

In connection with this, a new series of electric motors has been developed at one of the plants. The new series of electric motors has the same letter designations as the old one but with the addition of the number 2. For example, the new series of asynchronous electric motors of general industrial application is designated A2 when shielded and A02 when closed and air-blown. This same change is introduced also in the designation of electric motors of different modifications. For example, electric motors with an increased moment have the designations of types AP2 and AOP2.

Electric motors of the new series have a power up to 10 kilowatts only when shielded. The inlet device of the electric motors should be closed. Electric motors with a phase rotor are also made closed. New specialized modifications have been introduced, including low-noise motors with a built-in electromagnetic brake, chemically stable, telpher, mine, and other motors. The number of power steps has been increased for electric motors of small and medium power of the new series.

Series A2 and A02 electric motors also are being produced with increased slip for the textile industry, multi-speed, with an increased moment. This series also contains a group of specialized electric motors that are tropic, frost, chemical, and moisture resistant. The new series has various models in regard to the method of mounting (V4, V5, V6, Shch4, V6/V4 for electric motors of 6-9 dimensions).

Table 1

Index number of over-all dimension	1	2	3	4	5	6	7	8	9
Outside diameter of stator package, mm	133	153	180	208	243	291	343	393	458
Synchronous speed of rotation, rpm	3000 1500 1000	3000 1500 1000	3000 1500 1000	3000 1500 1000 750	3000 1500 1000 750	3000 1500 1000 750	3000 1500 1000 750	3000 1500 1000 750 600	3000 1500 1000 750 600

The outside diameters of the stator packages for A2 and A02 electric motors having a power from 0.6 to 100 kilowatts (with 1,500 rpm) have nine different diameters, in accordance with the nine over-all dimensions of the series (Table 1).

Table 1 also shows the speeds of rotation of the A2 and A02 electric motors of different over-all dimensions of general industrial application.

In regard to the method of mounting -- the new series of electric motors of general industrial application and also of electrical modifications and specialized application -- there are the models Shch2, Shch2/F2 for shielded and closed air-blown electric motors and the models V3, V4, V5, V6, Shch4, Shch5, V5/V3 only for closed air-blown electric motors.

The distribution of the power of the electric motors of the single series A2 and A02 with respect to standard dimensions as a function of the method of protection and the speed of rotation is shown in Table 2. The power scale of the electric motors of the series A2 and A02 corresponds to the recommendations accepted at the corresponding international conferences.

The nominal voltage of the electric motors is 220/380 and 380/500 volts.

The installation dimensions of the A2 and A02 electric motors having a speed of rotation of 1,500 rpm are listed in Table 3. In this table, the dimensions within the brackets are those which can be accepted after final testing of experimental specimens (see illustration).

Series A2 and A02 electric motors are made with cast-

Table 2

Overall dimension	Standard dimensions	Power, kwts.									
		Shielded A2					Closed, air-blown A02				
		3000 rpm	1,500 rpm	1,000 rpm	750 rpm	600 rpm	3,000 rpm	1,500 rpm	1,000 rpm	750 rpm	600 rpm
1	11	—	—	—	—	—	0,8	0,6	0,4	—	—
	12	—	—	—	—	—	1,1	0,8	0,6	—	—
2	21	—	—	—	—	—	1,5	1,1	0,8	—	—
	22	—	—	—	—	—	2,2	1,5	1,1	—	—
3	31	—	—	—	—	—	3,0	2,2	1,5	—	—
	32	—	—	—	—	—	4,0	3,0	2,2	—	—
4	41	—	—	—	—	—	5,5	4,0	3,0	2,2	—
	42	—	—	—	—	—	7,5	5,5	4,0	3,0	—
5	51	—	—	—	—	—	10	7,5	5,5	4,0	—
	52	—	—	—	—	—	13	10	7,5	5,5	—
6	61	17	13	10	7,5	—	—	13	10	7,5	—
	62	22	17	13	10	—	17	17	13	10	—
7	71	30	22	17	13	—	22	22	17	13	—
	72	40	30	22	17	—	30	30	22	17	—
8	81	55	40	30	22	17	40	40	30	22	17
	82	75	55	40	30	22	55	55	40	30	22
9	91	100	75	55	40	30	75	75	55	40	30
	92	125	100	75	55	40	100	100	75	55	40

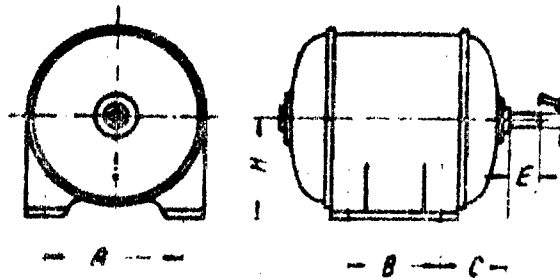

Installation dimensions of A2 and A02 electric motors

Table 3

Overall dimension	1	2	3	4	5						
Power, kwts	0,6	0,8	1,1	1,5	2,2	3	4	5,5	7,5	10	
Standard dimension	11	12	21	22	31	32	41	42	51	52	
Dimensions, mm	A	140	140	160	160	190	190	216	216	254	254
	B	100	125	112	140	114	140	140	178	178	210
	C	56	56	63	63	70	70	89	89	108	108
	D	18	18	22	22	28	28	32	32	38	38
	E	40	40	50	50	60	60	80	80	80	80
	H	90	90	100	100	112	112	132	132	160	160

Table 3 continued on next page

Table 3 continued from page 487

Overall dimension	6		7		8		9		
Power, kwts	13	17	22	30	40	55	75	100	
Standard dimension	61	62	71	72	81	82	91	92	
Dimensions, mm	A	279	279	356 (318)	356 (318)	406	406	457	457
	B	203	241	266 (228)	311 (.67)	311	349	368	419
	C	121	121	149 (133)	149 (133)	168	168	190	190
	D	42	42	48	48	60	60	70	70
	E	110	110	110	110	140	140	140	140
	H	180	180	225 (200)	225 (200)	251	250	280	280

iron bearing shields. Electric motors of 1-4 over-all dimensions are also being produced with bearing shields, using aluminum alloy of strengthened design as a base.

The windings of the shielded electric motors (dimensions 6-9) and closed air-blown electric motors (dimensions 1-5) have insulation of class E, which allows an excess temperature of 75°.

The windings of closed air-blown electric motors of dimensions 6-9 have insulation of class F, which allows an excess temperature of 100°.

The multiplicity of the starting current for series A2 and A02 electric motors is equal to seven--the greatest value permitted by GOST 186-52.

The speed in temperature increase of the stator winding of the electric motors of the new series is equal to 7° per second at starting. This speed of increase in the temperature assures electric motors with no damage to the insulation under a short-circuiting current when cold electric motors are connected with a braked rotor in the course of 15-20 seconds.

The labor requirement for producing electric motors of the new series is less than that of series A0 and A02 electric motors.

Only as a result of a decrease in the consumption of materials and an increase in the power indexes, the annual saving from the adoption of series A2 and A02 electric motors amounts to about 330 million rubles per year.

9. Electrochemical Sources of Current

Following is a translation of an article by P. D. Lukovtsev in Priroda (Nature), No. 12, December 1959, pages 22-28; CSO: 2900-N/11 (33)./

Electrochemical sources of current, i.e., devices by means of which the energy of chemical processes is converted directly into electrical energy are in many cases not interchangeable. These devices are simple in operation; they can be made of any weight, any dimensions and geometric shape. Electrochemical sources of current are comparatively slightly sensitive to outside effects--temperature, impacts and vibration, moisture, etc. All these properties have determined the wider field of application of storage batteries, cells, and batteries in comparison with other sources of electric feed. Devices for starting engines of automobiles and airplanes; submarines; electric trains and electric cars; artificial satellites of the earth and sounding balloons; means of communication, signallization, and automatism in railroad and water transport; portable radio receivers and magnetic sound recorders; pocket flashlights and audio apparatus; portable welding apparatus and electric clocks--this is a rather incomplete list of objects regarding which electrochemical sources of current have found application.

Depending on the intended use, the requirements imposed upon electrochemical sources of current are quite diverse, but essentially they amount to a maximum possible increase in the energy and power per unit weight or volume, i.e., to a reduction of the dimensions and weight, expansion of the working interval of the temperatures of the source, maintenance of constant voltage during the discharge and, finally, an increase in the service life and in shelf life. Practically most important is the requirement for a reduction in weight and dimensions of the source of current, inasmuch as they are used predominantly in movable objects.

An expansion in the field of application and an increase in the requirements imposed on the electrochemical sources of current stimulated the wide development of scientific investigations in this field. The results obtained have made it possible not only to improve the technical indexes of the existing but also to develop fundamentally new types of cells, batteries, and storage batteries. This progress was attained by the development of new designs of electrochemical sources of current, the utilization of new materials and new

electrochemical systems, and also by the use of improved technology.

A characteristic example of a change in the design of an electrochemical source of current is the development of so-called pie dry manganese-zinc batteries. In the dry battery of earlier design, which was assembled of zinc cells --cups, for the most dense packing of the latter, a substantial portion of the volume of the battery was not utilized. Assembly of the battery on the principle of voltage column from plane "pie" cells made it possible to utilize more fully the volume of the battery and to increase by 1.5-2 times the indexes with respect to specific energy.

Of great significance also was the improvement in the technology of the production of cells, batteries, and storage batteries. An example in this respect is the development of nonlamellar alkaline cadmium-nickel storage batteries. In alkaline storage batteries (of ordinary technology), the positive and negative electrodes (plates) are made by assembling lamellas, i.e., packages of perforated metallic foil with inclosed powders of active masses of mixtures of the oxides of nickel and graphite--for positive, cadmium and iron--for negative plates. In this case, the metallic casing of the lamellas shields the active masses and hinders their effective utilization. In nonlamellar storage batteries, the active masses of the electrodes are introduced by a special technological method into the pores of plates made by powder metallurgy from nickel powder. The porosity of such electrodes attains 80 percent. It is possible, in accordance with the nonlamellar technology, to produce thinner plates than for lamellar storage batteries with active masses which are utilized more effectively. This makes it possible to design storage batteries with high indexes as regards capacitance, power, and efficiency at low temperatures (down to -50°).

Nonlamellar plates do not swell during operation, which makes it possible to assemble storage batteries in plastic vessels. The use of nonlamellar technology made it possible to develop starter alkaline nickel-iron batteries which are not inferior to the volume and weight characteristics of lead-acid batteries but which have a service life several times longer. This is particularly important for reducing the operating cost of city automobile transport.

Dry galvanic cells and batteries have found the greatest application (it is more correct to call these cells batteries with thickened electrolyte). During the prewar period, they were produced essentially on the basis of the manganese-zinc electrochemical system: manganese dioxide (+) --salt electrolyte--zinc(-).

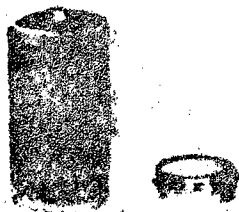

Fig. 1. Manganese-zinc(1) and mercury oxide(2) cells of the same capacitance.

However, the manganese-zinc cells and batteries have also substantial shortcomings which limit their use. These include the low specific power, dependence of capacitance on the force of the discharge current (load), and the inconstant voltage during the discharge. For this reason, during the development of dry cells and batteries, in addition to striving for a maximum reduction of the weight and dimensions, great efforts were directed to increase their power and improve the form of the discharge curve, i.e., the curve of the voltage as a function of the discharge time or capacitance liberated by the cell or battery during the discharge. Good results were obtained from the use of electrochemical systems of the type: mercury oxide (+)--alkaline electrolyte--zinc (-). Mercury oxide cells developed after the war operate at 1.25 volts and have comparatively high indexes of specific energy per unit volume as well as specific power. Such cells have, for the same capacitance, many times less volume than manganese-zinc cells (Fig. 1). The height of some mercury oxide cells is comparable with the thickness of one match, while the maximum diameter does not exceed its length (Fig. 2).



Fig. 2. Mercury oxide cells of different capacitance.

The electromotive force of mercury oxide cells changes little with time and temperature; for this reason, they can, in various cases, be used as standard cells. The utilization of semiconductor diodes and triodes, small-size parts, printed circuits together with mercury oxide cells makes it possible to develop rather miniature radio receivers, audio apparatus, magnetic sound recorders, and other devices. The shortcomings of these cells, in addition to their higher cost, are the small efficiency at temperatures below 0°.

Besides the mercury oxide cells, other dry cells with an alkaline electrolyte have been developed; for example, less costly manganese-zinc and air. The alkaline manganese-zinc cells have an inconstant voltage during the discharge. Dry air zinc-carbon and iron-carbon cells do not have this shortcoming and can be utilized in pocket flashlights, audio apparatus, and other devices. However, the technical characteristics of the air cells deteriorate noticeably with declining temperature, and below 0° the cells do not operate in a stable manner.

Very miniature dry indium cells made on the basis of the electrochemical system: mercury oxide (+)--alkaline electrolyte--alloy of indium with bismuth (-) differ from the mercury oxide cells with greater shelf life. They are intended for use in electric wrist watches. The substitution of zinc in mercury oxide cells by the titanium alloy made it possible to develop a cell which has a working voltage of one volt and is very stable at increased temperatures (80°). Their shortcoming--high temperature coefficient (1-1.5 millivolt/degree).

It is necessary to cite dry cells with potassium dichromate or vanadium pentoxide as the cathodes, which have found application in storage batteries designed for operation at low currents.

Recently, great interest has been displayed in batteries with solid electrolytes: solid salts or oxides having an ionic conductivity, ion exchange resins, and also solutions of solid electrolytes in polymers. Examples can be batteries of silver-iodine cells with the electrolyte of silver iodide and also silver-lead cells with an electrolyte of the chlorides of lead and silver. The electromotive force of the first cell is equal to 0.8 volts, that of the second--0.5 volts. These cells are assembled into small-size high-voltage batteries which are used in instruments requiring very small currents (less than one milliamperes/square centimeter of the electrode surface).

Manganese-zinc batteries and cells have also been designed in which the electrolyte is zinc chloride dissolved in a solid resin of polyethyleneglycol. It is assumed that the

shelf life of the batteries with the solid electrolytes can reach 20 years.

Storage batteries. As distinct from dry cells and batteries which have found wide application in electronic and other apparatus which require comparatively small currents, storage batteries are used chiefly in devices which require large currents, for example, as power devices on subsurface vessels and electric cars, for "ignition" in automobiles, for lifts, fire signals, etc.

The development of storage batteries proceeded in two directions. In the main, the efforts were directed to increase the specific energy and power of the storage batteries and also their climatic stability and service life. Intensive work was being carried on to develop air-tight or leak-proof storage batteries capable, in various cases, of replacing dry cells and batteries.

The most outstanding accomplishments during the last 10 years include the development of silver-zinc storage batteries which utilize the electrochemical system: oxide (peroxide) of silver (+)--alkaline electrolyte--zinc (-). Up to 1950, it was considered that such a system is suitable only for cells of single action, which are stored without the electrolyte directly before use. This was governed by the small shelf life of such elements, which is connected with the high speed of solution of the zinc in the alkaline solutions and the capacity of the silver oxides to be reduced by molecular hydrogen which is liberated as a result of the solution of the zinc.

The use of preparations of high purity, and also the utilization of cellophane as an interelectrode separation impermeable for large colloidal ions of silver and assuring the necessary ionic conductivity, made it possible to increase substantially the shelf life of the alkaline silver-zinc cells and, on this basis, to develop storage batteries having indexes of specific energy and power three to five times as great as of the existing lead-acid and alkaline cadmium-and iron-nichel storage batteries (Fig. 3).

The high indexes of the silver-zinc storage batteries with respect to the specific energy were attained not only through the utilization of the electrochemical process (1)

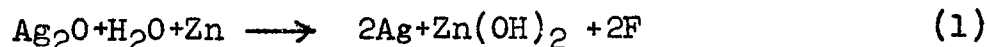

which gives a great energy effect per unit weight and volume of reacting substances, but also through the successful design of the storage batteries, which makes possible the rational utilization of its volume. In this storage battery, the electrodes of zinc and silver oxide, separated by a layer

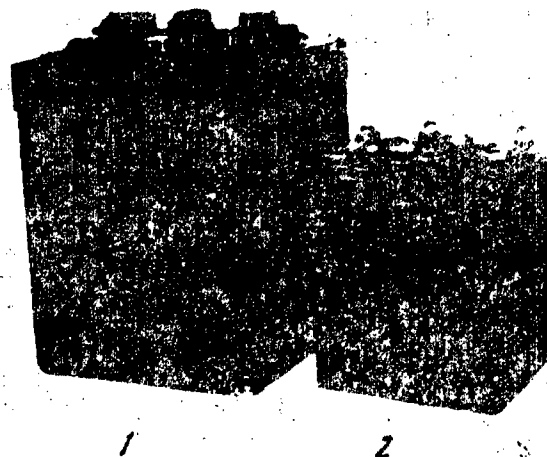
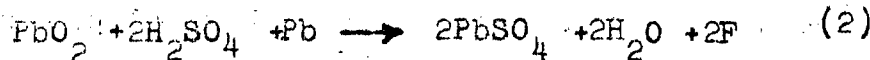

Fig. 3. Battery 6-volt of lead-acid (1) and silver-zinc (2) storage batteries of the same capacitance.

of cellophane, are packed densely in a plastic vessel.

It is interesting that in the given electrochemical process (1), the alkali is not consumed. This makes it possible to reduce the volume of the electrolyte in the storage battery to a minimum which is determined by the need to separate the electrodes with a medium of an ionic conductivity and by the requirement of water for the reaction (1). This advantage, as distinct from the acid storage batteries, is possessed by all electrochemical systems of alkaline storage batteries. Thus, for example, the operation of a lead-acid storage battery in accordance with the equation (2)



requires sulfuric acid, the concentration of which should not change within noticeable limits. The last is attained by a large amount of electrolyte in the storage battery.

Dense packing of the electrodes in the vessel and the small volume of free electrolyte make it possible to assure comparatively simply the stability

of the silver-zinc storage battery against mechanical action, non-leakage of the electrolyte, and efficiency at high altitudes. This makes the silver-zinc storage batteries irreplaceable for electric feeding of artificial satellites of the earth, portable television cameras, portable apparatus for point welding, bathyspheres, and other objects for which a small weight and small dimensions of the feed sources are of primary significance.

However, silver-zinc storage batteries also have shortcomings which limit their use. The most substantial of these is the short service life (in cycles) and the small shelf life after the start of the action, which is three to four times less than that of lead-acid batteries and 10-15 times less than that of alkaline cadmium-and iron-nickel storage batteries. The shelf life and service life of silver-zinc storage batteries are essentially determined by the chemical and mechanical strength of the separation film of cellophane; for this reason, at present all efforts are directed toward finding more stable materials.

The progress attained in the development of silver-zinc storage batteries has, to a certain extent, stimulated work for the development of new storage batteries (alkaline, silver-cadmium, silver-iron, silver-lead, and nickel-zinc) as well as for the improvement of the existing types. The above-enumerated new types of storage batteries are essentially still in the investigation stage. As regards their energy possibilities, they occupy an intermediate place between the cadmium-nickel and silver-zinc storage batteries. However, with respect to other indexes such as the service life and shelf life, some of these, for example, silver-cadmium, should excel the silver-zinc storage batteries.

Noticeable progress has been attained in the improvement of lead-acid, iron-nickel, and particularly cadmium-nickel storage batteries. These achievements were, in the first place, related to the use of improved technology, the utilization of new materials, including high polymers and plastics, activating and stabilizing additives to the electrodes and the electrolyte, as well as the development of new designs.

The utilization in cadmium-nickel storage batteries of foil electrodes made of fine metal foil which a layer of electrochemically active substance made it possible to increase substantially the indexes of the power and efficiency at low temperatures. Moreover, leak-proof and small-size, air-tight, cadmium-nickel storage batteries were developed which successfully replace dry cells and

batteries in various installations.

The liberation of hydrogen and oxygen on the electrodes during the charging and storage in the charged state of alkaline cadmium-nickel storage batteries served as the basic hindrance which it was possible to overcome in the development of hermetically sealed storage batteries. This was attained by different methods--the use of valves which automatically start to function at increased pressure in the storage battery, the use of catalysts which facilitate the processes of ionization of hydrogen and oxygen directly in the very storage battery, etc. Hermetically sealed storage batteries can be included in the circuit of the devices which require the current. They are particularly convenient when used in combination with solar batteries. Thus, in the case of portable radio receivers developed on this basis, the reserve capacitance of their feeding storage batteries is supplemented from solar batteries.

The shortcomings of hermetically sealed storage batteries include their small efficiency at low temperatures. Recently developed hermetically sealed alkaline silver-lead storage batteries have indexes of specific energy 1.5-2 times greater than similar cadmium-nickel storage batteries and are distinguished by stability of the discharge voltage; they are successfully replacing dry mercury oxide cells.

Reserve or activated cells and batteries. The attempts to utilize chemical sources of current electrochemical systems which give a large energy effect has led to the development of reserve or activated cells and batteries which are activated during or not long before use. Their activation is accomplished by the introduction of electrolyte or water; in other types, this is accomplished by feeding liquid or gaseous active substances to the electrodes. The principles forming the basis of the design of such cells cannot be considered new because even in the last century batteries were used with electrodes immersed in the electrolyte before use.

The most widely used of the reserve cells and batteries are the water-activated silver-magnesium and copper-magnesium one based on the electrochemical systems:

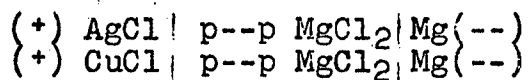

Such batteries in the inactive state can be kept for a long time in air-tight packages. In the activated state they have a small shelf life and, for this reason, should be used within one to two days. Their activation is accomplished by immersion for a short time (5-10 minutes) in water

(potable, sea, etc.). In the first moment after inclusion of the load, the voltage of the cells of the battery, as a result of the low conductivity of the electrolyte, is less than normal, but after a certain time, with the accumulation in the electrolyte of the product of the electrochemical reaction -- $MgCl_2$, the internal resistance of the cells falls and the voltage increases to a value of 1.3-1.4 volts depending on the load (Fig. 4).

Magnesium cells and batteries excel the manganese-zinc cells with respect to the specific power. They heat up noticeably during operation; for this reason, their electrical characteristics do not practically change with the changing temperature of the surrounding medium, particularly if measures have been taken for the thermal insulation of the cells. The magnesium cells and batteries are used for feeding the apparatus of sounding balloons, signal devices, and other purposes.

Higher indexes of specific power and energy are exhibited by cells and batteries with a cathode of lead dioxide and anodes of cadmium, zinc or lead activated by solutions of acids: sulfuric (for Cd and Zn anodes), hydrochloric, hydrofluoroboric or fluosilicic acid (for Pb anode). Such batteries have a smaller shelf life when activated, but, on the other hand, they develop a greater power (up to 0.6 kilowatt/kilogram). The best characteristics, particularly at low temperatures (down to -60°), are shown by batteries with hydrochloric, fluosilicic and hydrofluoroboric acids, which is explained by the good solubility of the products of the electrode reactions in these acids.

An example of cells which are activated by feeding oxidizers or reducing agents to the cathode or anode are the chlorine and sodium cells. In the chlorine cell, the activation takes place by feeding gaseous chlorine from a cylinder to the carbon cathode. In the sodium cell, tablets of sodium amalgam are periodically fed into the electrolyte and are used as the anode material.

Cells have also been proposed which are activated by heat. As an example, we can point to the cell with a cathode of manganese dioxide, and anode of magnesium, and an electrolyte of solid anhydrous caustic soda. In the inactivated state, the cell has a long shelf life and can operate on very small currents just as all the other cells with solid electrolytes. However, after its activation by heating to the melting point of the electrolyte (320°), the cell can operate at comparatively large loads (3 milliamperes/square centimeter of anode surface) and a voltage of 1.3 volts.

Cells of continuous action. Fuel cells. At the present time, considerable interest is being exhibited toward

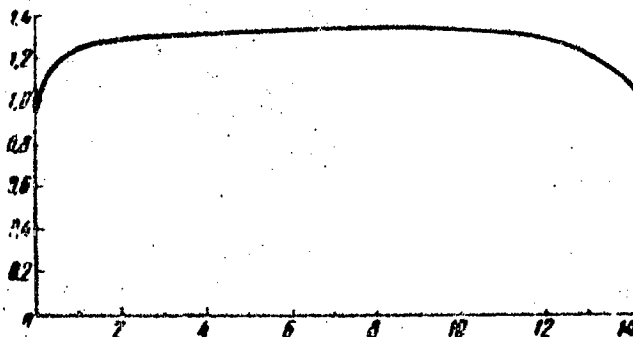

Fig. 4. Curve of voltage--time of the discharge of a copper-magnesium cell.

elements of continuous action, during the operation of which the electrochemically active substances or the electrolyte are fed continuously into the reaction zone. The advantages of these cells are in the small polarization of the electrodes, high efficiency, long service life, and other characteristics which it possible to employ electrochemical systems in those places where the utilization of ordinary cells is difficult. As an example of this is the already mentioned chlorine or sodium and also gaseous hydrogen-oxygen cells.

The development of gaseous hydrogen-oxygen cells should be regarded as the first step in the solution of the problem of a fuel cell in which the chemical energy of the combustion of the fuel is converted directly into electrical energy. Recently, interest in this problem which was advanced as far back as the Seventies of the previous century by P. N. Yablochkov has increased noticeably.

At the present time, two types of hydrogen-oxygen cells are close to practical realization. In the Bacon cell the electrochemical process



proceeds at a high pressure (50 atmospheres) and a temperature of 200° on the boundary between the porous nickel electrodes and the alkaline electrolyte. Rather high current densities (0.6 amperes/square centimeter) can take place in this cell; however, its design and operation are rather complex.

The hydrogen-oxygen cell, which operates at a low pressure (1-2 atmospheres) and a temperature below 100°, deserves great attention. The electrodes in this cell are made of carbon, activated platinum, or other metals. The

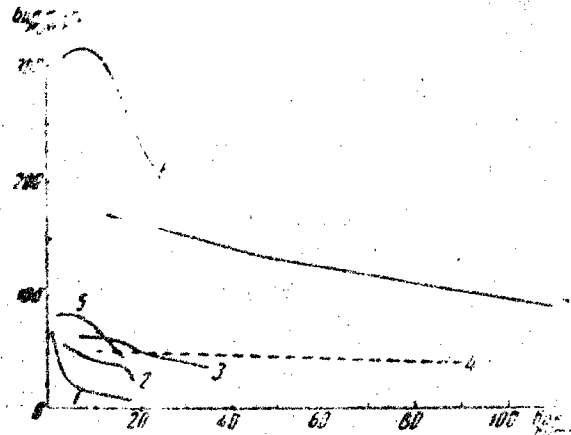

Fig. 5. Specific energy per unit volume as a function of the specific power for different electrochemical sources of current: 1--manganese-zinc batteries; 2--cadmium-nickel storage batteries; 3--lead-acid storage batteries; 4--nonlamellar cadmium-nickel storage batteries; 5--copper-magnesium cells; 6--mercury oxide cells; 7--silver-zinc storage batteries.

electrolyte is a solution of caustic potash. Continuous operation of the cell is assured by the fact that the water which forms as a result of the electrochemical reaction (3) is vaporized with the same speed with which it forms. This cell develops a smaller power than the Bacon cell but is more convenient in practice.

It is assumed that the hydrogen-oxygen cells which have an efficiency two to three times greater than internal combustion engines can replace the latter, for example, in railroad transport. They can also be utilized for storing energy received from windmills, helio installations, etc. The hydrogen and oxygen necessary for the operation of the cell are obtained by the electrolysis of water.

The prospects of further wide application of hydrogen-oxygen cells is closely related with the preparation, transportation, and storage of hydrogen. Hydrogen-oxygen cells operate on hydrogen of comparatively high purity. In connection with this, it is of great significance to develop cells in which it would be possible to utilize hydrogen obtained in the cracking of natural gases as well as from the reaction of carbon with water.

In this respect, investigations in the field of high-temperature fuel cells with a solid electrolyte, which operate at temperatures above 500° and which utilize not only

hydrogen but also other combustible gases (CO, hydrocarbons, etc.), are of interest.

Problems and prospects. The above presentation shows that during the last 10-15 years in the development of electrochemical sources of current noticeable progress has been attained on the use of new electrochemical systems. An illustration of this is the comparison of the indexes of specific energy and power of manganese-zinc batteries, alkaline cadmium-nickel, and lead-acid storage batteries with the indexes of the new sources of current (Fig. 5). The existing electrochemical sources of current far from completely satisfy in a satisfactory manner the continuously growing requirements imposed upon them. For this reason, one of the most important problems in this field was and remains the problem of the maximum increase of the technical indexes of existing and the development of new cells with higher indexes of specific energy and power, service life, and shelf life, efficiency within wide limits of temperatures.

At the present time, it is possible to formulate more concrete problems, the solution of which would be of great significance for the national economy. First of all, it is necessary to create a storage battery which would have high indexes of service life and shelf life, the production of which would not require critical and nonferrous metals. The solution of such a problem would make it possible to utilize on a greater scale the energy of winds, solar radiation, etc. for the electrification of the country and also to improve substantially the atmosphere of large cities by replacing in automobiles the internal combustion engines with engines which operate on storage batteries.

The second, no less important, problem is the development of a reliably operating fuel cell; in the first place, a gaseous cell, which would make it possible to utilize more fully the energy of the fuel in particular, the energy of natural gases. The solution of the indicated problems will require the expenditure of large efforts to overcome the difficulties of a scientific as well as of a technical nature. It can be found on the basis of a wider utilization of scientific accomplishments of theoretical and applied electrochemistry as well as of related branches of science.

10. Miniature Incandescent Lamps for 110-230 Volts

Following is a translation of an unsigned article in Svetotekhnika (Lighting Engineering), No. 3, March 1960, page 32; CSO: 2900-N/11 (34).⁷

Miniature, low-power special incandescent lamps for 110-230 volts are intended for local illumination, light signals, illumination of instrument scales, and other purposes.

The lamps have considerably smaller over-all dimensions than incandescent lamps of the same power of general use. In the case of some lamps, the decrease in the dimensions is obtained through a reduction of the life, and in the case of others, through a reduction in the light emission.

The incandescent body of the lamps is in the form of a tungsten spiral mounted on molybdenum holders. The shells of the lamps have a cylindrical, spherical, or conical form. In the case of STs-19 lamps, the shell has an outside matte surface. All the lamps are being produced with a vacuum, the gas rarefaction in the shell being 10^{-4} -- 10^{-5} millimeters of mercury.

For connecting to the electrical network, the lamps are equipped with a threaded or prong base in accordance with GOST 2520-51. It is permitted to replace the threaded R14 bases by the 1Sh15 and 2Sh15 prong bases. In case of such a substitution, the complete length of the lamp is reduced by six millimeters. It is also permitted to replace the R27 threaded bases for the 2Sh22 prong bases. In case of such a substitution, the complete length of the lamp is reduced by three millimeters.

The type SG13 and SG14 lamps are equipped with the 2F-DZO focusing disk base in accordance with GOST 6129-52. The incandescent body of these lamps has a width not more than 12 millimeters, a thickness not over four millimeters, and a height not over 14 millimeters. The use of a focusing base and the observance of accurate dimensions of the incandescent body makes it possible without regulation (in the illuminating device) to combine the light center of the lamp with the focus of the optical system. All the lamps can operate in any position. The design of the lamps makes it possible to operate them under conditions of vibration with an acceleration up to 2.5 g.



Fig. 1

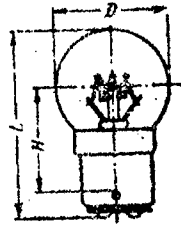

Fig. 2

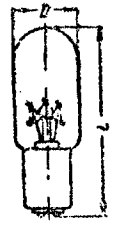

Fig. 3

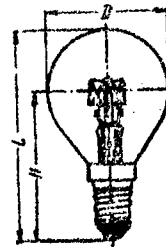

Fig. 4

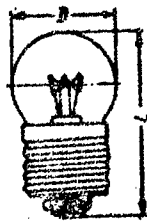

Fig. 5



Fig. 6



Fig. 7



Fig. 8

Type of lamp	Nominal values				Average duration of burning, hours	Minimum average finite light stream, lumens	Maximum diameter of bulb, D mm	Maximum complete length of lamp, L mm
	Voltage, volts	Power, watts	Light stream, lumens	Light emission, lumens/watt				
STS-21	110	8	52	6.5	300	37	26	59
STS-9	110	15	76	5.0	300	54	33	56
STS-19	120	15	98	6.5	300	70	20	60
TS-10	120	25	125	5.0	300	90	43	75
STS-89	127	8	36	4.5	1 000	27	26	59
STS-36	127	10	58	5.8	400	40	33	59
STS-31	127	15	105	7.0	400	74	33	59
STS-15	230	15	95	6.3	500	68	43	75
TS-3	110	15	105	7.0	1 000	76	20	86
TS-10	110	15	105	7.0	1 000	76	31	86
TS-11	110	25	190	7.6	1 000	139	25	86
TS-4	110	25	190	7.6	1 000	139	31	86
TS-12	127	15	105	7.0	1 000	76	20	86
TS-13	127	15	105	7.0	1 000	76	31	86
TS-14	127	25	190	7.6	1 000	139	25	86
TS-15	127	25	190	7.6	1 000	139	31	86
TS-16	220	25	157	6.3	1 000	113	25	86
TS-17	220	25	157	6.3	1 000	113	31	86
S-31	127	8	31	3.9	1 000	22	20	61
PSh-1	127	15	105	7.0	500	76	26	53
PSh-2	220	15	80	5.3	500	54	26	53
SG-13	110	15	105	7.0	500	68	25	83
SG-14	110	25	190	7.6	500	122	25	83
RT220-15	220	10	50	5.0	1 000	36	25	86
RT230-25	230	25	100	6.0	500	108	25	86

Table continued on next page

L

Table continued from page 657

Height of light center, H mm	Type of Base	Purchase cost, rubles	Manufacturing plant	Number of illustrations
43	R14	0.90	Tomsk Electric Lamp Plant	4
30	2Sh122	0.90	Moscow Electric Lamp Plant	2
-	2Sh115	1.15	The same	3
51	R14	1.30	The same	4
43	R14	0.90	The same	4
-	R27	1.00	The same	5
-	R27	1.00	The same	5
51	R14	1.20	The same	4
-	R14	0.90	Tomsk Electric Lamp Plant	6
-	R27	0.90	The same	7
-	R14	0.95	The same	6
-	R27	0.95	The same	7
-	R14	0.90	The same	6
-	R27	0.90	The same	7
-	R14	0.95	The same	6
-	R27	0.95	The same	7
-	R14	1.05	The same	6
-	R27	1.05	The same	7
-	R14	2.00	Moscow Electric Lamp Plant	6
-	R14	2.00	Tomsk Electric Lamp Plant	8
-	R14	2.00	The same	8
35	2F-D30	2.00	Moscow Electric Lamp Plant	1
35	2F-D30	2.00	The same	1
-	R14	0.95	Tomsk Electric Lamp Plant	6
-	R14	1.05	The same	6
-	R14	1.05	The same	6

END

FOR REASONS OF SPEED AND ECONOMY
THIS REPORT HAS BEEN REPRODUCED
ELECTRONICALLY DIRECTLY FROM OUR
CONTRACTOR'S TYPESCRIPT

THIS PUBLICATION WAS PREPARED UNDER CONTRACT TO THE
UNITED STATES JOINT PUBLICATIONS RESEARCH SERVICE
A FEDERAL GOVERNMENT ORGANIZATION ESTABLISHED
TO SERVICE THE TRANSLATION AND RESEARCH NEEDS
OF THE VARIOUS GOVERNMENT DEPARTMENTS