

QUEST Technical Report No. 709

**ULTRAHIGH-PRESSURE WATERJETS FOR COKE
REMOVAL IN JET ENGINE FUEL TUBES,
WITH LASER-OPTIC INSPECTION**

D. E. Steele, J. L. Doyle,
D. O. Monserud, and P. J. Miles

April 1996

Prepared for
KELLY AIR FORCE BASE-ALC
Under Contract No. F41608-95-C-1139

DISTRIBUTION STATEMENT A
Approved for Public Release
Distribution Unlimited



QUEST INTEGRATED, INC.
21414 - 68th Avenue South
Kent, Washington 98032
(206) 872-9500

19990421 055

REPORT DOCUMENTATION PAGE

Form Approved
OMB No 0704-0188

Public reporting burden for this collection of information is estimated to average 1 hour per response, including the time for reviewing instructions, searching existing data sources, gathering and maintaining the data needed, and completing and reviewing the collection of information. Send comments regarding this burden estimate or any other aspect of this collection of information, including suggestions for reducing this burden, to Washington Headquarters Services, Directorate for Information Operations and Reports, 1215 Jefferson Davis Highway, Suite 1204 Arlington, VA 22202-4302 and to the Office of Management and Budget, Paperwork Reduction Project (0704-0188), Washington, DC 20503

1. AGENCY USE ONLY (Leave blank)	2. REPORT DATE April 1996	3. REPORT TYPE AND DATES COVERED Final, 09/19/95 - 02/29/96	
4. TITLE AND SUBTITLE Ultrahigh-Pressure Waterjets for Coke Removal in Jet Engine Fuel Tubes, with Laser-Optic Inspection		5. FUNDING NUMBERS F41608-95-C-1139	
6. AUTHOR(S) D. E. Steele, J. L. Doyle, D. O. Monserud, and P. J. Miles			
7. PERFORMING ORGANIZATION NAME(S) AND ADDRESS(ES) QUEST Integrated, Inc. 21414 - 68th Avenue South Kent, Washington 98032		8. PERFORMING ORGANIZATION REPORT NUMBER QUEST Technical Report No. 709	
9. SPONSORING MONITORING AGENCY NAME(S) AND ADDRESS(ES) Department of the Air Force SA-ALC/Propulsion Directorate 303 Wilson Blvd. Ste 3 Kelly AFB, Texas 78241-5443		10. SPONSORING MONITORING AGENCY REPORT NUMBER	
11. SUPPLEMENTARY NOTES			
12a. DISTRIBUTION AVAILABILITY STATEMENT Approved for Public Release; Distribution is Unlimited.		12b. DISTRIBUTION CODE A	
13. ABSTRACT (Maximum 200 words) Phase I feasibility was shown for the dual new technologies of UHP waterjet cleaning and laser-optic inspection of coke-encrusted jet engine fuel manifolds. Hard deposits build inside long, convoluted, small-diameter tubes and frequently require tube replacement. Ultrahigh-pressure waterjets were evaluated as an economical and environmentally friendly means to completely remove coke deposits without detriment to tube walls. A laser-optic surface mapping method was evaluated as a technology that could provide both quantitative measurement of tube inner diameters, with up to 0.001 inch accuracy, and qualitative imaging of the inner tube surface. The cleaning study showed that plain waterjets can controllably remove the subject carbon deposits. While low pressure was effective on lighter deposits, maximum pressure (as high as 55,000 psi) was important for heavy deposits and blockages. Hardware assemblies were developed and successfully demonstrated for packaging the jets for use in tubes. Laser-optics were breadboarded in a package suitable for the tube size and demonstrated successfully. It was found that laser-optic data could produce both digital video images and accurate dimensional information. These cleaning and inspection technologies have flexibility for alternate uses, including heat exchanger tubes and process piping. Preliminary commercial systems will be prototyped in Phase II.			
14. SUBJECT TERMS Waterjet, UHP, Decarburize, Cleaning, Carbon, Tube, Nondestructive Inspection, Laser Optic, Laser Triangulation		15. NUMBER OF PAGES 57	16. PRICE CODE
17. SECURITY CLASSIFICATION OF REPORT Unclassified	18. SECURITY CLASSIFICATION OF THIS PAGE Unclassified	19. SECURITY CLASSIFICATION OF ABSTRACT Unclassified	20. LIMITATION OF ABSTRACT Unlimited

SUMMARY

Experimental investigations were conducted to determine the feasibility of using waterjets to remove fuel tube coke deposits and using laser optics as the basis for a fuel tube inspection system. Hard and previously untreatable, coke deposits build along convoluted inner surfaces of fuel tubes and manifolds in a variety of jet engine applications. Ultrahigh-pressure waterjets, to 55,000 psi, were evaluated as an economical and environmentally friendly means to selectively remove coke deposits with no effect to sensitive tube walls. In addition, a laser-optic surface mapping method was evaluated as a technology that could provide both quantitative measurement of a tube's inner diameter, with up to 0.001 inch accuracy, and qualitative imaging of the inner tube surface. Both technologies were demonstrated as not only feasible, but very promising to this and several other commercial applications.

The cleaning study included development and demonstration of the waterjet process and the preliminary nozzle hardware. Waterjet cleaning was explored in depth and compared briefly to plastic grit abrasive-waterjets and cryogenic fluidjets. It was found that waterjet coke removal is effective at either high pressure (with continuous traverse), or low pressure (with intermittent dwell). Fan jets at 1.75 gpm were effective at 55,000 psi and a high incidence angle, while round jets worked best at lower pressure (15,000 to 25,000 psi) and medium to low (45 to 0 degrees) incidence angles. Multiple nozzle/conduit geometries were developed and successfully tested. Cryogenics and plastic grit were shown to be promising alternates to plain water.

Laser-optic inspection was evaluated as a means of finding and characterizing coke deposits, as well as inspecting clean tubes after processing or as part of manufacturing. It was found that a rotating inspection probe could be built small and flexible enough to move throughout the baseline tube geometry. It was also found that laser-optic data could produce both digital video images and accurate dimensional information.

The identified technologies will allow both selective or complete tube cleaning and inspection, with flexibility for use with many different tube sizes and shapes. Potential applications other than jet fuel tubes include marine power plant (nuclear and fossil) heat exchangers, petroleum and chemical industry process plumbing, pulp and paper plant boiler systems, and in situ nuclear reactor maintenance. Phase I included the preliminary design of industrial systems, with an analysis of the positive economics. Phase II objectives include optimization of the processes and hardware, the building/testing of prototype cleaning and inspection systems, and the delivery of those prototype systems to the Air Force for in-service evaluation.

TABLE OF CONTENTS

Report Documentation Page.....	i
Summary.....	ii
List of Figures	v
List of Tables.....	vii
Introduction	1
Background	1
Objectives.....	2
Technical Approach	2
Task 1. System Specifications	2
Task 2. Waterjet Process Development.....	3
Task 3. Design and Testing of Flexible Wand Compact Nozzle.....	3
Task 4. Laser-Optic Inspection System	3
Task 5. Conceptual Design of Prototype Systems.....	4
Task 6. Economic Analysis and Final Report (Final Deliverable).....	4
System Specifications	4
Kelly Air Force Base - ALC Maintenance Depot.....	4
Description of Baseline Tubes	5
Initial Process Requirements.....	5
Characterization of Coke/Carbon Deposits.....	7
Experimental Setup	7
Test Specimens	7
Waterjet Cleaning Test Hardware and Instrumentation	8
UHP Pump System	8
Adept Robot	8
UNIMATE 6000.....	8
Video Microscope	8
Test Lathe.....	9
Laser Inspection Test Hardware and Instrumentation	9
Flexible Video Probe.....	9
Laser Sensor Probe.....	9
Signal Processing Electronics	10
Data Acquisition and Display	10
Experimental Investigation.....	10
Alternate Media Survey	10
Plastic Grit Abrasive Waterjet	10
Cryogenic Liquid Nitrogen Jet.....	13
Waterjet Coke Removal and Tube Cleaning	15
Waterjet Process Development	15
Flexible Wand and Nozzle Development.....	22
Laser Inspection.....	30
Laser-Based Triangulation Background.....	30
Breadboard Evaluation.....	34
Discussion	34

TABLE OF CONTENTS (CONT.)

Waterjet Cleaning	34
Cleaning Effectiveness	38
The Value Added by UHP	41
Conceptual Design of an Industrial System	41
Recommended Waterjet System Features	50
Recommended Laser Inspection System Features	51
Cost of UHP Waterjet Cleaning: Economic Analysis	51
Laser Inspection	53
Conclusions and Recommendations	55
Waterjet Cleaning	55
Laser Inspection	56
References	58

LIST OF FIGURES

Figure 1. Baseline Tube Illustration.....	6
Figure 2. Section of Carbon-Blocked Volkswagen Manifold.....	8
Figure 3. Modified 5/8-Inch LOTIS Probe.....	9
Figure 4. Conceptual Block Diagram of the Prototype Circuit Board.....	11
Figure 5. Laboratory Setup.....	12
Figure 6. Comparison of Plastic and Garnet Abrasives.....	12
Figure 7. Plastic Grit AWJ.....	13
Figure 8. UHP Cryogenic (Nitrogen) Cleaning.....	14
Figure 9. Jet Fuel Tube Before and After Cryogenic Cleaning.....	15
Figure 10. Waterjet Cleaning Fundamentals.....	16
Figure 11. UHP Waterjet Process Development - Round Jets.....	19
Figure 12. UHP Waterjet Process Development - Fan Jets.....	21
Figure 13. Example of Heavy Coke Removal Via Fan Jet (Volkswagen Tube).....	22
Figure 14. Geometric Considerations for the Wand and Nozzle.....	24
Figure 15. Flexible Hose as Flexible Conduit.....	26
Figure 16. Rigid Tubing as Flexible Conduit.....	29
Figure 17. Operation of LOTIS™ Model 400-N.....	31
Figure 18. Laser Triangulation.....	31
Figure 19. Lateral Effect Photodetector.....	32
Figure 20. LOTIS Laser Scans a Helical Path Along the Tube Surface.....	32
Figure 21. Cross-Sectional View.....	33
Figure 22. Contour View.....	33
Figure 23. Cross-Sectional View of Tube with ID Scale.....	35
Figure 24. Cross-Sectional View of Tube with ID Scale.....	35
Figure 25. Test Setup for Rotating Waterjet Nozzle and Traversing Tube Sections.....	36
Figure 26. Waterjet Nozzle Inserted in Curved Tube Section for Cleaning.....	36
Figure 27. Two-Jet Nozzle Assembly Showing Angled 0.018-Inch Jet Streams.....	37
Figure 28. Four-Jet Nozzle Assembly Showing Angled 0.018-Inch Jet Streams.....	37
Figure 29. Flexible Hose with Custom Four-Jet Nozzle Entering Actual Jet Engine Tube Section.....	38
Figure 30. Hypodermic Tubing Wand Nozzle with Collet and Soft Seal.....	38
Figure 31. Actual Jet Engine Tube End Before Cleaning with Waterjet.....	39
Figure 32. Actual Jet Engine Tube End After Cleaning with Waterjet.....	39
Figure 33. Microphotograph of Coke Deposit on Actual Jet Engine Tube.....	40
Figure 34. Microphotograph of Jet Engine Tube After Waterjet Coke Removal.....	40
Figure 35. Conceptual UHP Waterjet Tube Cleaning System.....	42
Figure 36. System Block Diagram.....	43
Figure 37. Conceptual Design of Adapter Connections and Stoke/Rotation Drives.....	44
Figure 38. Flow International Model 20X Intensifier Pump.....	46
Figure 39. Control Panel Display.....	47
Figure 40. Data Acquisition Display.....	48
Figure 41. Flow International Water Recycling System.....	49
Figure 42. Overall Waterjet Fuel Tube Cleaning Operational and Capital Cost Relationships.....	52
Figure 43. Waterjet Fuel Tube Cleaning Cost Relationships.....	52

LIST OF FIGURES (CONT.)

Figure 44. Laser Video Image of the Tube Surface	54
Figure 45. Photograph of Tube with Coke Deposit	54
Figure 46. Laser Video Image of a Business Card.....	55
Figure 47. Conceptual Illustration of Probe	57
Figure 48. Articulated Sensor Driven by an External Drive System	57
Figure 49. Full System Illustration.....	58

LIST OF TABLES

Table 1. Test Matrix for Cleaning Process Development.....	18
Table 2. Test Matrix for Wand Nozzle Development.....	23
Table 3. Operational and Capital Waterjet Fuel Tube Cleaning Costs.....	53
Table 4. Fuel Tubes.....	53

INTRODUCTION

This report describes the results of an exploratory experimental investigation into the two complementary technologies of ultrahigh-pressure (UHP) coke removal/tube cleaning and laser-optic inspection. The work was conducted as a Phase I SBIR (Small Business Innovative Research) program for Kelly Air Force Base-ALC, San Antonio, Texas, by QUEST Integrated, Inc., under Contract No. F41608-95-C-1139.

BACKGROUND

During the course of normal operation, jet engine components, such as fuel tubes, flow nozzles, and manifolds, are susceptible to the build up of hard coke (carbon) deposits. Such deposits, combined with oxidation and other petroleum and combustion residues, degrade engine efficiency and cooling ability (Sweetman, 1993), and can accumulate to such a level as to completely block off internal fuel manifold passages. In order to eliminate the economic impact and downtime associated with premature engine removal and the replacement of blocked fuel tube/manifold components, periodic maintenance procedures are undertaken to clean coke deposits from critical engine components. Maintenance schedules depend on the engine type, use, and specific component, but typically may call for cleaning after 1000, 1500, or 2000 hours.

Periodic removal of harmful coke deposits is currently accomplished either by traditional chemical dissolution or the relatively new abrasive flow method. Neither method is effective against completely blocked tubes. In addition, complete inspection of the long, curved, small-diameter internal surfaces is difficult or impossible using existing technology. Thus, there is significant need for a new coke removal method, as well as a new inspection technique.

A coke removal process based on the impact power and stress intensity of a UHP pure waterjet offers significant potential in the case of jet engine component cleaning. Waterjet technology has reached the point where continuous fluid pressures of 100,000 psi are being focused through orifices as small as 0.001 inch, and pulsejets can effectively double or triple that power in a cleaning application. With an absence of mechanical contact or abrasives, a key attraction to pure waterjet coke removal is the inherent safety to parent material. For an initial capital investment comparable to the cost of the traditional dissolution chemical recycling system (Permanganate Rejuvenation System, Technology Transition Office, 1991), a waterjet removal system will offer significant savings in terms of cycle time and lifecycle operating cost. The waterjet offers effective, environmentally friendly, and workpiece-safe removal of coke deposits.

When using waterjets for actual coke removal, inspection is desirable before and after cleaning to quantify carbon deposits, identify surface damage in the parent material, and detect the presence of completely blocked ports. Existing nondestructive examination techniques are difficult to use or entirely ineffective for use with many fuel tube and manifold part geometries. Part geometries vary, but internal dimensions from fractions of inches to dozens of inches are not uncommon, and long small-diameter passages with sharp or complex bends are typical.

Laser-optic triangulation is a technology recently developed by QUEST specifically for inspection of small tubes. It enables highly accurate characterization of inner surfaces, providing exact (to less than 0.001 inch) dimensions of internal geometries along the complete bore length and showing all surface flaws and irregularities. Laser-optic inspection has the potential for full characterization of internal

surfaces for the detection of not only coke deposits, but also tube scratches, pits, and wear. Combined with easily-obtained outer part dimensions, local wall thicknesses are determined. Laser-optic tube inspection technology, like UHP waterjet cleaning, is ideal for jet engine tube application.

In this Phase I effort, QUEST has demonstrated the feasibility of a UHP waterjet-based cleaning and clearing method and a laser-optic tube inspection system for use with jet engine fuel tube and manifold components. QUEST is particularly enthusiastic about this work and the results of Phase I. As a result of our initial success, representatives from Pratt and Whitney have come forward with interest in similar engine cleaning applications, and representatives of Knowles Atomic Power Labs have expressed interest in transferring this demonstrated technology for use with the next-generation shipboard reactor heat exchanger tubing. Success in Phase II will open both existing and developing markets to these new technologies.

OBJECTIVES

The stated objectives of Phase I included the following:

1. Demonstrate UHP waterjet removal of coke/carbon deposits on exposed surfaces.
2. Design, build, and test flexible and compact wand nozzle for insertion in baseline curved tubes.
3. Demonstrate UHP waterjet cleaning, including the clearing of blockages, with new nozzle inside baseline tubes.
4. Design and breadboard a flexible and compact laser-optic tube inspection system for use in baseline curved tubes.
5. Establish specifications and a preliminary design of complete cleaning and inspection process for industrial use in jet engine coke removal.

TECHNICAL APPROACH

Achieving the Phase I objectives required a six-task program, as stated below:

- Task 1: System Specifications
- Task 2: Waterjet Process Development
- Task 3: Development and Testing of Flexible Wand Compact Nozzle
- Task 4: Laser-Optic Inspection System
- Task 5: Conceptual Design of Prototype Systems
- Task 6: Economic Analysis and Final Report

This section briefly summarizes work performed under each of these tasks. The results of this work are presented and discussed in more detail in following sections.

Task 1. System Specifications

A meeting was held with the technical project manager for the Air Force and QUEST's principal investigator to discuss the many factors associated with the cleaning and inspection of jet engine fuel tube and manifold components. This meeting resulted in a preliminary system specification and the selection of a baseline tube geometry.

Specific designs of the fuel tubes and manifolds to which the Phase I solicitation was directed vary within any particular engine, as well as between engine models and manufacturers. With the variety of part sizes and geometries for which waterjet coke removal has potential, the meeting discussion included topics such as workpiece specifics, the nature of blockages, and the desired degree of cleanliness. In addition, discussions addressed the desired level of automation, operator interfaces, safety provisions, system packaging constraints, and portability requirements. Sample jet engine parts with actual coke deposits were provided at this meeting.

Regarding tube inspection, topics of discussion included: current inspection requirements, current inspection methods, safety provisions, data storage and transmission formats, system packaging constraints, and portability requirements.

Task 2. Waterjet Process Development

This task consisted of a brief experimental investigation to determine the relative performances of a variety of jet configurations on representative coke deposits. Establishing the fundamental performance relationships here facilitated the wand nozzle development in the next task.

Task 3. Design and Testing of Flexible Wand Compact Nozzle

A general-purpose waterjet cleaning tool suitable for small-diameter curved fuel tubes must incorporate a nozzle head compact enough to enter long tubes, and have a nozzle body and high-pressure feed line thin and flexible enough to follow the head as it is pushed through a tube and around internal bends. In this task, suitable wand-type nozzles were built and tested.

The results of Task 2 dictated initial design parameters. Both round jets and fan jets were candidates.

As will be shown, tested hardware was based both on high-pressure hose and flexible metal tubing. Numerous configurations were designed, built, and tested in our lab tube cleaning setup. This task was one of the biggest and most important, since it was essential to the project to show that jets of sufficient pressure could be packaged for delivery through the baseline tubes. The results of this task are described in detail, with accompanying photographs, illustrations, and charts, in later sections of the report.

Task 4. Laser-Optic Inspection System

In this task, a laser-optic inspection system suitable for use in small-diameter tubes was breadboarded and bench tested. As will be presented in depth with the discussion of results, the scope of the original inspection proposal was exceeded with the early discovery that a rotating single-beam head could be used instead of an array of discrete fixed laser beams. This opened the door for the development of another novel enhancement, namely digital laser imaging. The proposed inspection system provided not only tube diameter data, but also actual internal surface profilometry data at all axial positions within any part bores. As completed, the Phase I effort provided not only this information, but also a laser-generated digital video image. This imaging technology capitalizes on the different surface reflectivities of carbon deposits and the stainless tube and makes it possible to differentiate between actual carbon deposits and other tube flaws such as scratches and dents.

Task 5. Conceptual Design of Prototype Systems

At the conclusion of the waterjet process development and the inspection system breadboarding, the conceptual design of industrial-grade cleaning and inspection systems was generated. Included were hardware and process specifications, as well as the results from the waterjet nozzle design study in Task 3. This task provided an opportunity to lay the groundwork for a full-capability cleaning/clearing machine to be prototyped in Phase II.

Task 6. Economic Analysis and Final Report (Final Deliverable)

With the system specifications and process development work complete, an economic analysis was performed. This takes into account both initial capital costs, as well as ongoing operating and maintenance costs, and shows the economic advantages associated with waterjet cleaning of jet engine tubes. As will be seen, a conservative cleaning system payback period was calculated at 36 months. Added to these attractive economics is the benefit of having tube-repair capability at all, which in times of high demand can be the difference between jets in the air and jets on the ground. This very real factor, combined with the economics, strongly supports waterjet tube cleaning.

SYSTEM SPECIFICATIONS

Kelly Air Force Base - ALC Maintenance Depot

Early in this project, a visit was made to Kelly Air Force Base to discuss current tube cleaning and inspection needs, practices, and future needs. Kelly is one of several Air Logistics Centers in the United States used by the Air Force as depots for plane and engine maintenance activities.

Engines are typically taken from field service after accumulating thousands of cycles and brought to engine maintenance depots for complete repair and restoration. Depots typically specialize in particular engines, such as the F100, TF-39, and T-56 models at Kelly. Depots have highly specialized equipment for rebuilding the components of the engines they maintain, as new parts are expensive, and availability of new pieces can be questionable in the critical times of military conflict. Jet engine tubing, however, represents an expensive element of all jet engines for which effective rebuilding tools are not currently available.

Approximately 100 jet engines are rebuilt at Kelly each month. Engine rebuild activities include engine disassembly, inspection, cleaning, re-manufacturing, sub-assembly, and final assembly. Virtually every part is removed, and almost all are reused.

Component inspection is currently done to evaluate the reusability of key parts using a combination of visual inspection, die penetrant, and precision measurement. The new automated die penetrant machine at Kelly does all preparation work ahead of visual black light inspection (which is still manual). Precision measurements are made with traditional measurement tools and coordinate measurement machines.

Reusable parts are cleaned in a fully automated chemical cleaning area. A grid of chemical tanks, approximately 6 feet square and 6 feet deep, hold cleaning chemicals and neutralizing agents. Baskets are conveyed via an overhead track system and lowered in specific baths for time periods based on the parts and materials in the baskets.

Remanufacturing steps for each engine component follows procedures established in a Tech Order (T.O.), which is a product of the original manufacturer and the Air Force. A typical tubing T.O. includes alkaline cleaning, dent removal, and furnace baking. Unfortunately, this does not work to remove baked coke deposits typical inside long, twisted, small-diameter fuel tubes. Without being able to remove coke deposits, these tubes do not pass flow tests required for acceptance. Standard procedure at Kelly is to look at tubes in inspection, immediately condemn any with deposits, and buy new replacements. According to one source, tubes are the biggest category item in jet engines for which no effective cleaning methods had been developed before this Phase I investigation.

Increasing budget pressures are forcing the future closure of Kelly AFB, and maintenance operations will likely be shuffled among remaining facilities. Engines will still need rebuilding, however, and the potential for saving money by means of waterjet cleaning and thorough inspection will have new significance.

Description of Baseline Tubes

During the Kelly visit, the Air Force Technical Representative identified two augmentation fuel tubes in the F100 engine as the baseline tubes for programmatic cleaning and inspection work.

There are many tubes in an engine like the F100, but only a few accumulate coke deposits. One example is the small-diameter, high-pressure tubes used as manifolds and fuel flow tubes outside the engine housing. These lead to the burner nozzles. Fuel in these tubes is fast moving, and the temperature in that part of the engine is relatively low, combining to discourage formation of coke deposits. At the rear augmentation (afterburner) section of the engine, however, temperatures are very high, tubes are larger in diameter, and fuel tends to sit in them and bake. Afterburner spray rings in the engine itself get too hot for coke, but the fuel manifolds around the outside of the can get "coked up" to the point of completely plugging. On the F100 engine, the afterburner manifold is made up of two primary tubes. For the purposes of this Phase I investigation, dirty samples of these tubes were provided.

The two specific jet fuel engine manifold tubes selected as the development baseline include PN #4045658 and PN #4045660, both "Augmentor Spray Manifolds". In order to service these tubes, the following specifications were established as the basis for our Phase I cleaning and inspection efforts.

- Tube Outer Diameter: 0.562 inch
- Tube Wall Thickness: 0.035 inch
- Maximum Tube Length: 70 inches
- Minimum Centerline Bend Radius: 2.0 inches, for angles between 20 and 90 degrees
0.281 inch (sharp inside bend) for angles less than 20 degrees
- Maximum Bend Angle: 90 degrees
- Tube Material: Stainless steel, alloy unknown
- Tube Access: Generally from either/both ends, although a 90-degree end fitting may interfere

These specifications are illustrated in Figure 1.

Initial Process Requirements

Initial process requirements were selected based on standard practices at Kelly AFB and current state of the art in UHP system design and laser inspection. A summary of these requirements follows.

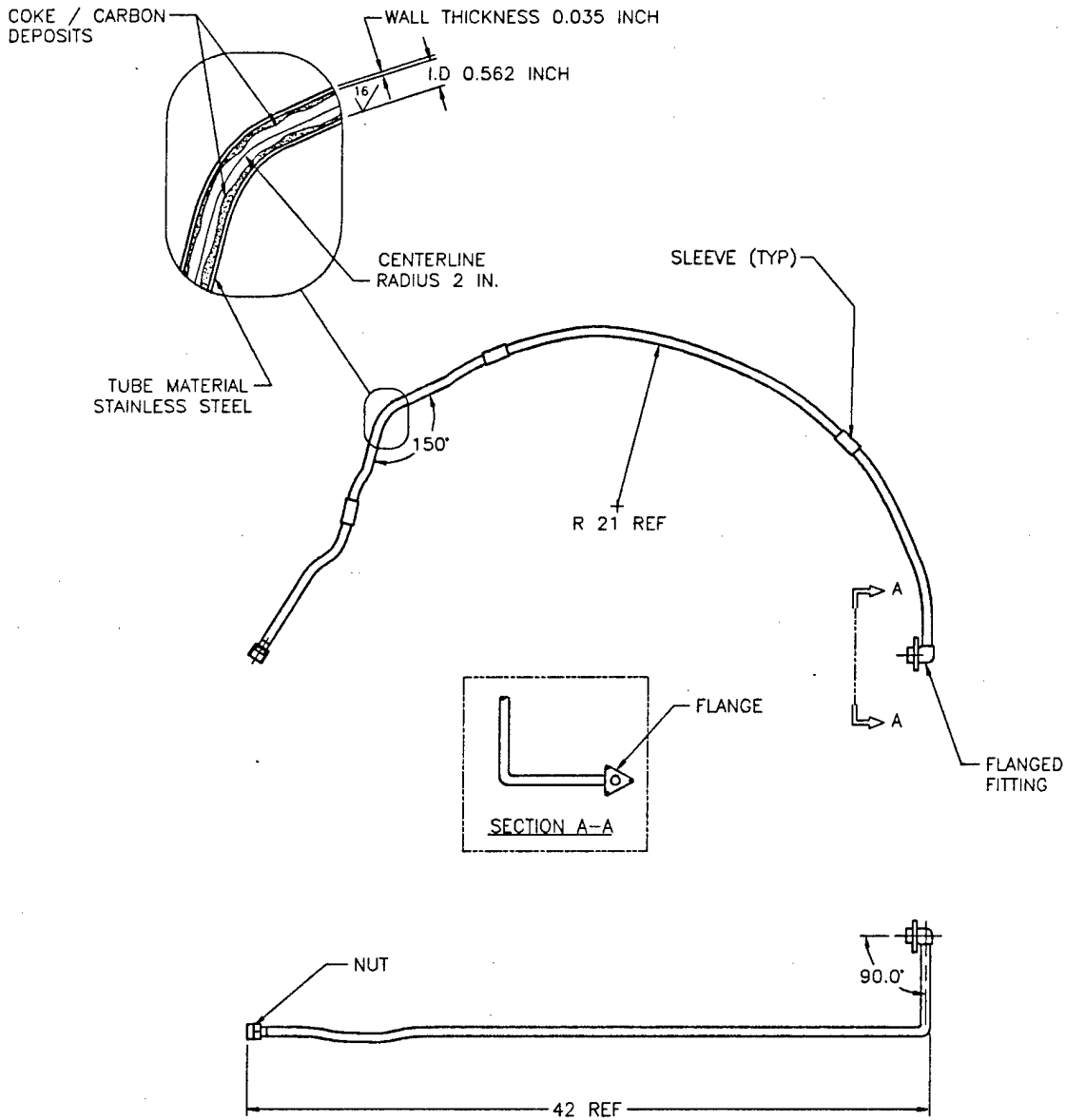

Figure 1. Baseline Tube Illustration

Cleaning Process Requirements

- Friendly to environment and personnel
- No abrasive elements that could damage tube material
- Minimal, if any, part-specific tooling
- Cleaning fluid pressures up to 55,000 psi
- Cleaning fluid flow rates up to 2 gpm
- Water as cleaning media, filtered through 1 micron absolute
- Plant water supply: UHP supply - 3-gpm water filtered to 10 micron absolute
- Cooling water supply - 5-gpm water at 90 degrees Fahrenheit maximum

Inspection Process Requirements

- Nondestructive
- Low power (preferably Class I)
- Simple to operate
- Accuracy in the range of 0.001 inch
- Quantitative data
- Possible for automatic data storage

Characterization of Coke/Carbon Deposits

An effort was initially made to characterize the actual coke deposits. In general, elemental carbon exists in amorphous forms, including coke, charcoal, and carbon black, besides the crystalline forms of diamond and graphite. In its strictest definition, coke is a fuel used in the reduction of metallic oxides to free metals, and itself is produced by heating coal in the absence of air. In jet engine fuel tubes hydrocarbon jet fuel is heated, and carbon deposits form on the tube walls. These too are referred to as "coke". Unfortunately, it was beyond the scope of Phase I to completely analyze the deposits for the determination of microhardness, chemical composition, ash content, adhesion, and crystallinity.

EXPERIMENTAL SETUP

The experimental portion of this investigation was conducted using two different test specimens and several existing QUEST-owned machines and instruments. These are described briefly below.

Test Specimens

Test samples used in this study included actual tube sections and some simulant tubes. The actual stainless tube samples provided by the Air Force had coke deposits that covered approximately 95% of their inside surfaces but were only a few thousandths of an inch (up to 0.005 inch) thick. In order to test carbon removal of heavier deposits, an automotive fuel manifold section was identified that characteristically gets significant carbon build-up. Volkswagen Type-I intake manifold heat risers are 0.5-inch ID steel tubes, which can get completely plugged in service (see Figure 2). Several scrap samples of these tubes were acquired.

Straight and curved sections were cut from both actual and simulant tubes for test purposes.

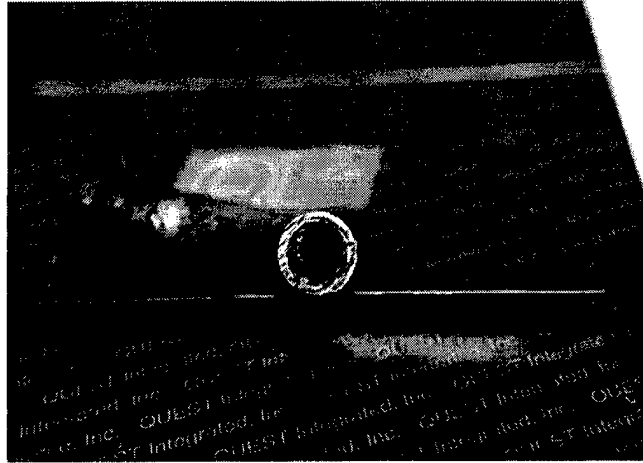

Figure 2. Section of Carbon-Blocked Volkswagen Manifold

Waterjet Cleaning Test Hardware and Instrumentation

UHP Pump System

QUEST's waterjet technology laboratory is equipped to perform waterjet and abrasive-waterjet (AWJ) cutting experiments involving fluid pressures as high as 100,000 psi (700 MPa). Over 1100 hp (820 kW) of high-pressure water can be supplied to the various laboratory robotic manipulator systems that are on hand. Seven UHP intensifier pumps covering a range of testing parameters are available for R&D activities.

Adept Robot

The Adept I manipulates waterjet and AWJ nozzles in five axes and has a manipulator vision system for tool-tip coordinate identification and parts inspection. The nozzle is equipped with automated tool-change capability and advanced sensors for process control. Turning, drilling, and cutting can be programmed for automatic operations using a PC-based controller.

UNIMATE 6000

The UNIMATE 6000 is available for studying and developing AWJ/waterjet machining operations for large, thick workpieces. It is capable of traversing at velocities up to 1200 in./min (50 cm/s) per axis and has a working envelope of 10×4×3 ft (3×1.2×0.9 m), a repeatability of ±0.005 in. (0.127 mm), accuracy of 0.005 in./ft (0.4 mm/m), and a payload of more than 200 lb (90 kg).

Video Microscope

A Leica EpiStar IC Inspection/Metallurgical Microscope was used to document waterjet cleaning performance. Connected to a Mitsubishi CP15U Color Video Copy Processor and a Sony color monitor, the microscope produced color photographs of tube wall microstructure. Objective lenses from 6.5 to 100× enabled high-resolution imaging of both carbon deposits and stainless steel.

Test Lathe

Special QUEST AWJ/waterjet machining test facilities and equipment were modified for use on this program. Included is a modified conventional lathe and auxiliary traverse system (previously used for the development of deep-hole drilling capabilities). Plumbed with QUEST hoses and rotary unions, this equipment enabled testing rotating nozzles as they were translated through tube sections.

Laser Inspection Test Hardware and Instrumentation

The experimental setup was comprised of two systems; a flexible video probe and a laser-based probe and support electronics configuration.

Flexible Video Probe

In order to obtain a visual assessment of the condition of both the fully coked and cleaned tubing without having to destructively evaluate the tubing, QUEST employed a Welch-Allen Excel 875 Video Probe. This device allowed operators to insert a small, flexible probe into the tubing and establish a visual baseline of the condition of the tubing under all conditions. This device was used periodically throughout the project in order to augment the inspection process. Due to cost constraints, we chose not to acquire digital images of the video output, but rather employed the device as a visual tool only.

Laser Sensor Probe

At the outset of this program it was envisaged that tubing as small as 0.188 inch would be the target size to be inspected. After the kick-off meeting on October 3, 1995, however, two sample engine manifold tubes were selected (PN# 4045658 and PN# 4045660 [augmentor spray manifolds]).

The only drawback associated with the concept described in the original Phase I proposal was that by using an array of transmitters, which are multiplexed onto a single axially oriented LEP, the spatial resolution is limited to the number of transmitting and receiving optical elements that can be packaged in a small probe. If, on the other hand, a single laser transmitter and detector assembly can be rotated as it is drawn through the tube, nearly infinite spatial resolution can be attained. Since the nominal tube ID is 0.492 inch, we had the benefit of being able to employ a previous LOTIS design with only a few minor mechanical modifications. Since the probe was not articulated, we could only acquire data on straight sections of the tube. However, as described later in this document, an articulated probe can be developed for this application. Figure 3 shows the modified 5/8-inch LOTIS probe (Model 5/8S-P-R3) that was used for the laboratory tests. The housing has been removed to reveal the internal components.

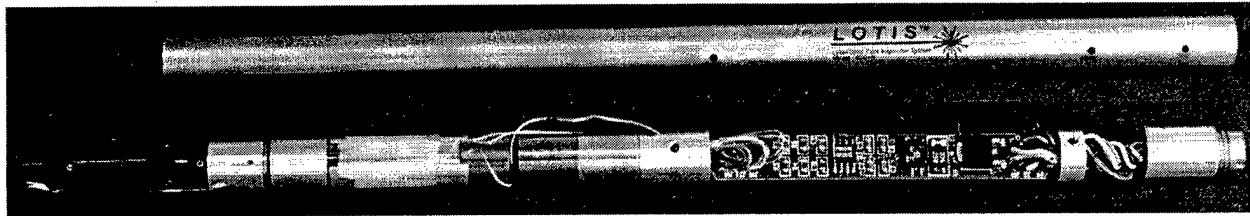

Figure 3. Modified 5/8-Inch LOTIS Probe

Signal Processing Electronics

In order to obtain data of the resolution necessary to accurately locate any remaining coke deposits, QUEST modified an existing prototype LOTIS Model 500 circuit board to operate with the probe described previously. The Model 500 circuit board was configured to acquire 2,880 samples per revolution and a rotational speed of 1800 rpm. Figure 4 shows a conceptual block diagram of the prototype circuit board used to support the laboratory testing.

Data Acquisition and Display

A Pentium computer was used for data acquisition analysis and display. Preexisting acquisition and display software from both LOTIS NDE systems and other in-house applications was employed to evaluate the test data. Figure 5 shows the laboratory setup.

EXPERIMENTAL INVESTIGATION

This study was predominantly experimental in nature. Work was divided between development of the waterjet cleaning process, the waterjet cleaning hardware, and the inspection hardware. Engineering resources were used in analysis of the fuel tube application and in the design of test hardware. Hardware subsystems were fabricated, assembled, and tested. The inspection system included both hardware and software development, debugging, and demonstration. Existing hardware and instrumentation was used extensively, with necessary custom-built hardware based on readily available components as much as possible.

Alternate Media Survey

QUEST has significant experience with alternate ultrahigh-pressure and high-pressure fluid jet technologies, which could be useful for jet engine maintenance. Suspension jet cutting, polymer-water jetting, cryogenic fluid jetting (for cutting or cleaning), and soft media AWJs are examples of these alternate technologies. A brief exploration of these alternate options to waterjets was conducted.

Suspension jets and polymer waterjets were not evaluated, as prior experience indicated they would not offer significant gains for this application.

Plastic Grit Abrasive Waterjet

Soft abrasives can be accelerated by a high-velocity waterjet in the same way hard abrasives are entrained in a UHP AWJ. Directed at a target material, these AWJs remove material primarily by an impact/spalling mechanism, which is typically much more aggressive than the relative performance of a plain waterjet. Using plastic media provides some of the advantages of this more aggressive cleaning without the associated risk to the parent material.

For these tests, a commercially available melamine thermoset plastic grit was used in a 30/40 sieve size corresponding to 0.017- to 0.023-inch particles. This was within the size range used more commonly in typical garnet sand abrasives, and the two abrasive grits are compared in Figure 6. Both are irregular, with relatively sharp edges.

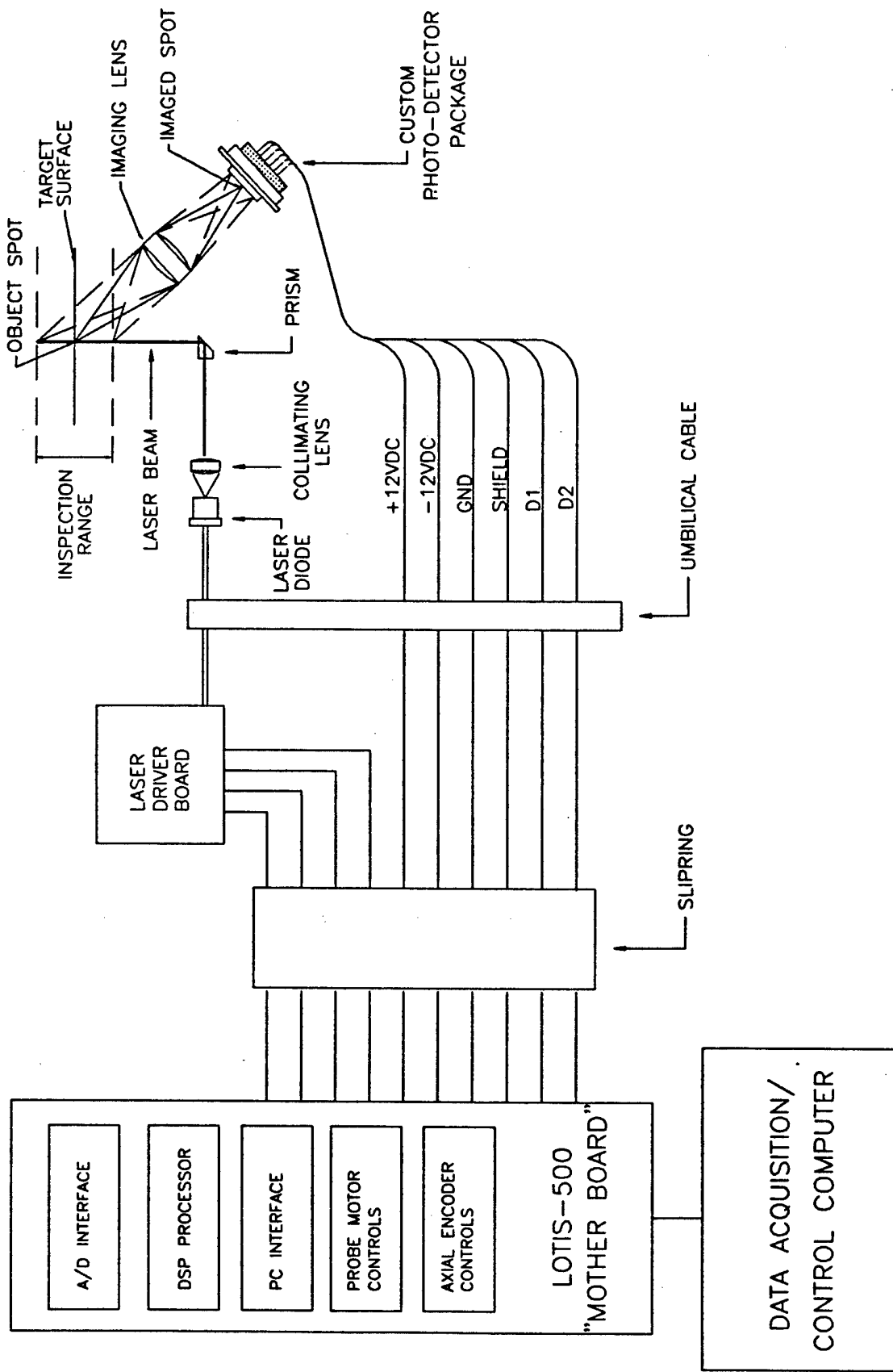

Figure 4. Conceptual Block Diagram of the Prototype Circuit Board

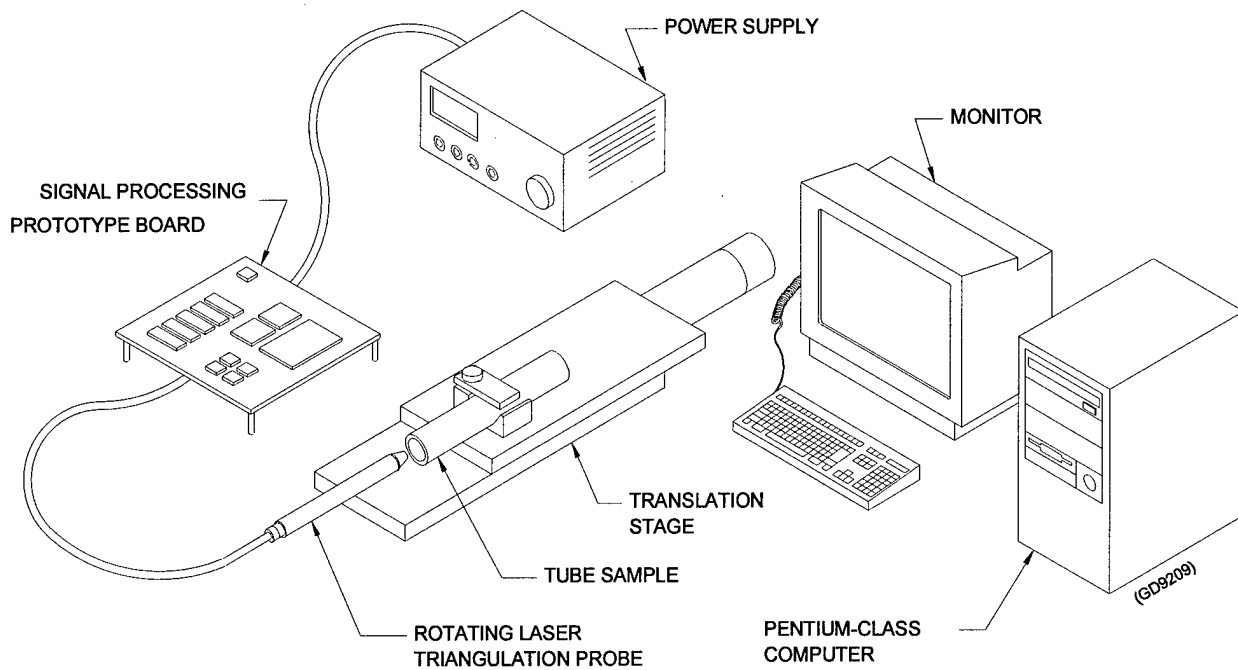

Figure 5. Laboratory Setup

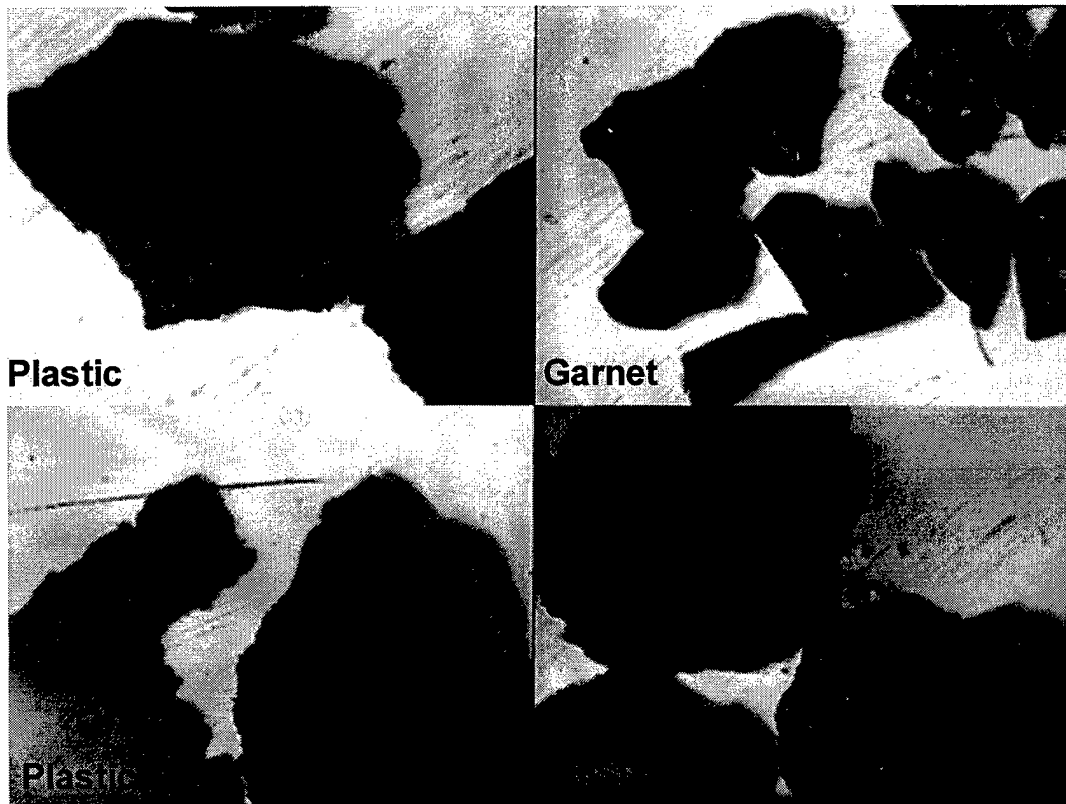

Figure 6. Comparison of Plastic and Garnet Abrasives

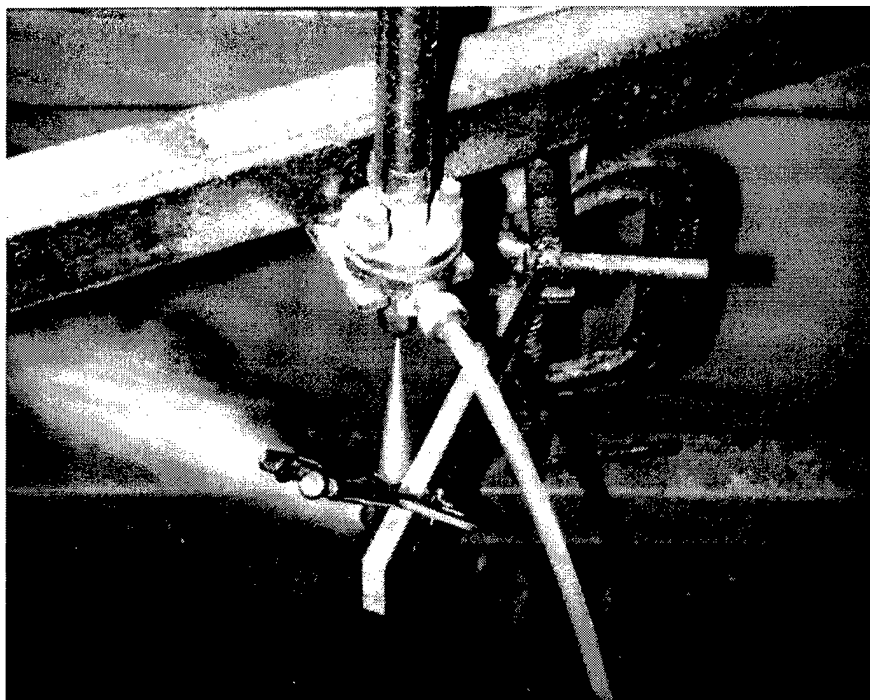

Figure 7. Plastic Grit AWJ

An AWJ nozzle was positioned over the open end of a fuel tube section, and the jet fired into the tube as shown in Figure 7. The nozzle standoff was set such that the jet beam spread to fill the tube as it entered. Plastic grit particles then passed through the tube with random bouncing motions, scouring the tube wall.

At 55 ksi, with a 0.013-inch orifice and 0.26 pounds/minute of grit, the AWJ demonstrated excellent cleaning. It was easy to not only remove the carbon, but remove tube material as well. It was determined that any further testing should be conducted at lower pressure, with smaller orifices, and modified plastic flow rates. Further plastic-grit AWJ testing, however, was out of the scope of Phase I. This technology remains quite viable as an enhancement to plain water and should be further tested in Phase II.

Cryogenic Liquid Nitrogen Jet

Cryogenic fluid jets are in the early stages of exploration. Cryogenic fluids, such as liquid nitrogen and carbon dioxide, are characterized by very low boiling points and extremely low temperatures in liquid form at atmospheric pressure. Advantages for jet cutting and cleaning are related to the absence of waste, since the jet fluid evaporates moments after being discharged from the nozzle, and the low temperatures.

An existing QUEST cryogenic jetting system was used to quickly compare fuel tube cleaning with water and liquid nitrogen (LN_2). The tube sample, in this case, was split lengthwise and positioned under the jet (Figure 8). A pass was made with the jet at 15,000 psi.

The cryogenic jet was effective in removing coke deposits. Photographs of a tube sample before and after cleaning are shown in Figure 9. As in the case of plastic grit AWJ cleaning, this technology is viable as an alternate to plain water. Further testing in Phase I, however, was limited to the baseline plain waterjets.

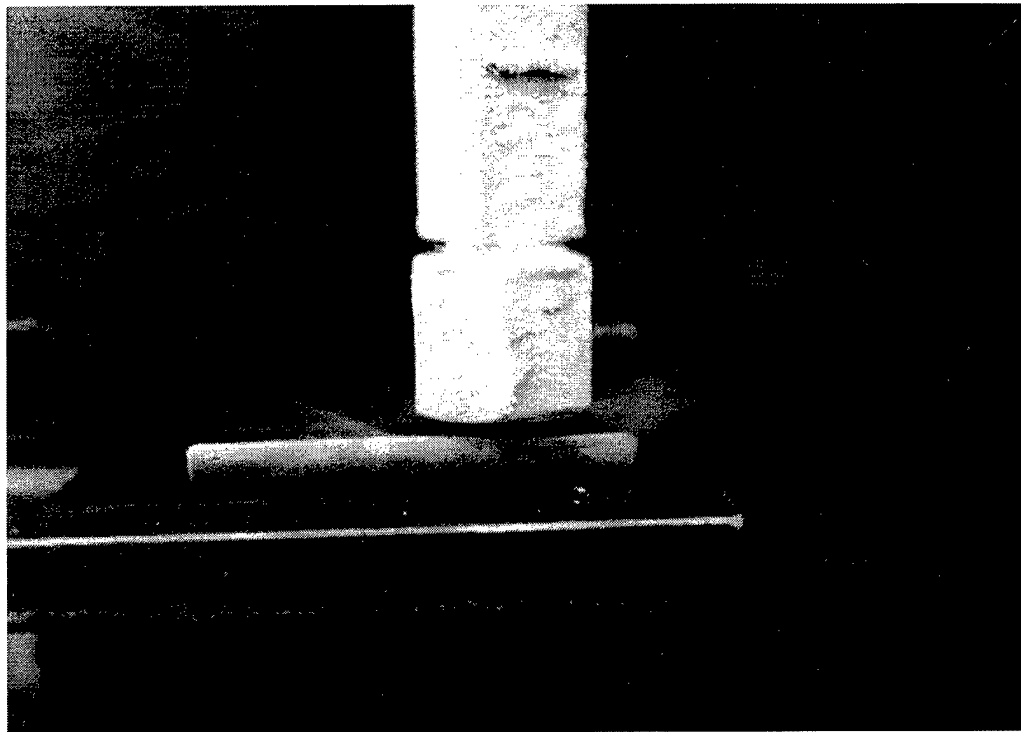
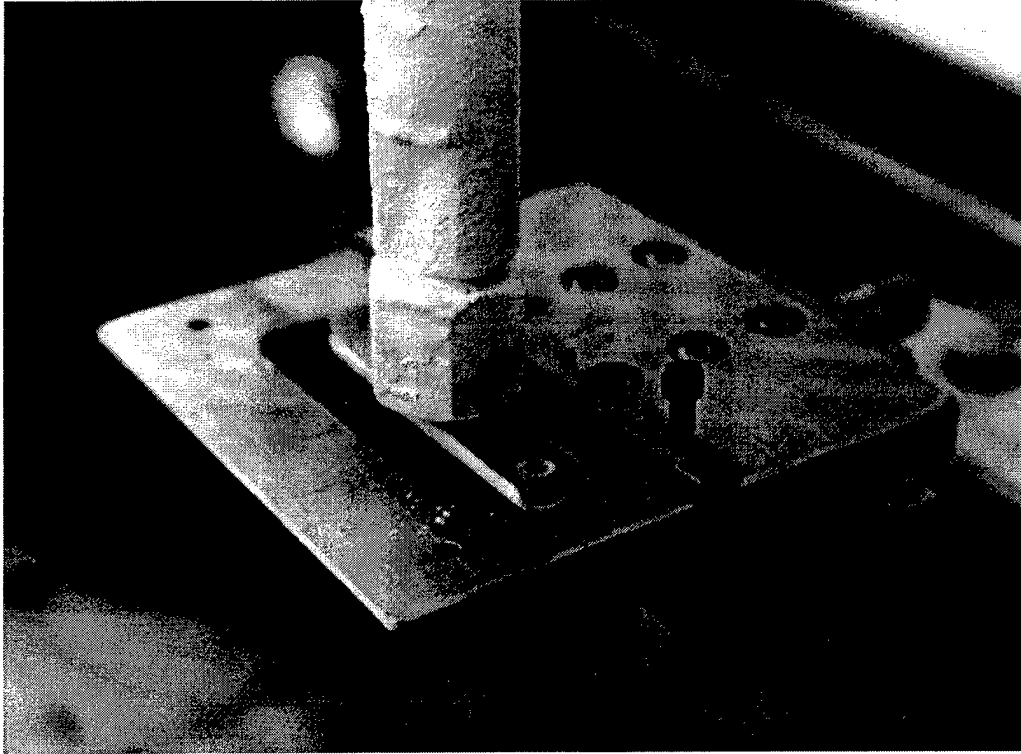
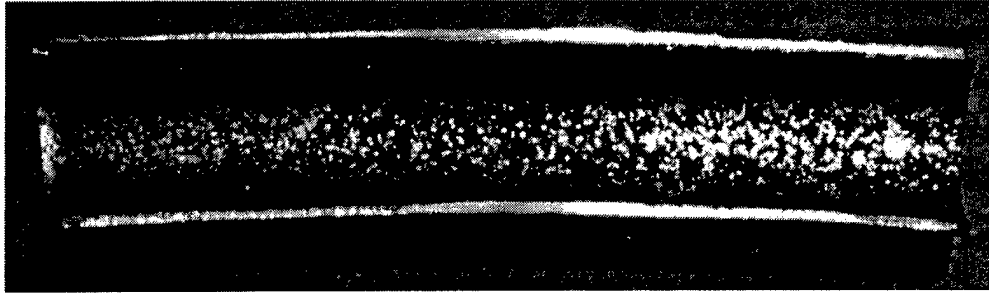
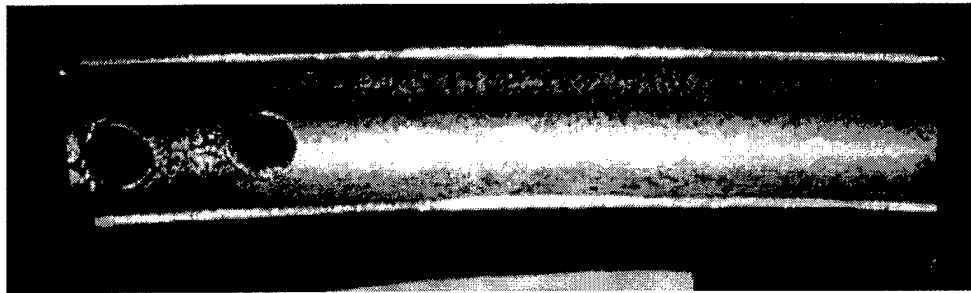

Figure 8. UHP Cryogenic (Nitrogen) Cleaning



a. Before cleaning



b. After cleaning

Figure 9. Jet Fuel Tube Before and After Cryogenic Cleaning

Waterjet Coke Removal and Tube Cleaning

Developing and demonstrating an effective and industrially-feasible waterjet coke removal mechanism was the highest priority of Phase I. Jet engine fuel tube cleaning represented a new application with two primary technical challenges, including:

- Developing a waterjet process by which coke could be effectively removed without damage to the tube wall and upon which an industrial cleaning system could be feasibly based.
- Developing a nozzle and high-pressure fluid conduit system that would be small enough to fit inside the slender tubes, flexible enough to navigate the various tube bends, and effective for any thickness (including blockages) of coke deposit.

Waterjet Process Development

The process development task of Phase I was conducted using two different lab setups. Initially, tube sections were split open lengthwise to expose the carbon deposits and fixtured statically under the QUEST Unimate Robot. Both round jets and fan jets were traversed axially over the test samples, varying jet parameters including pressure, flow, standoff distance, incidence angle, and traverse rate. These parameters are illustrated in Figure 10.

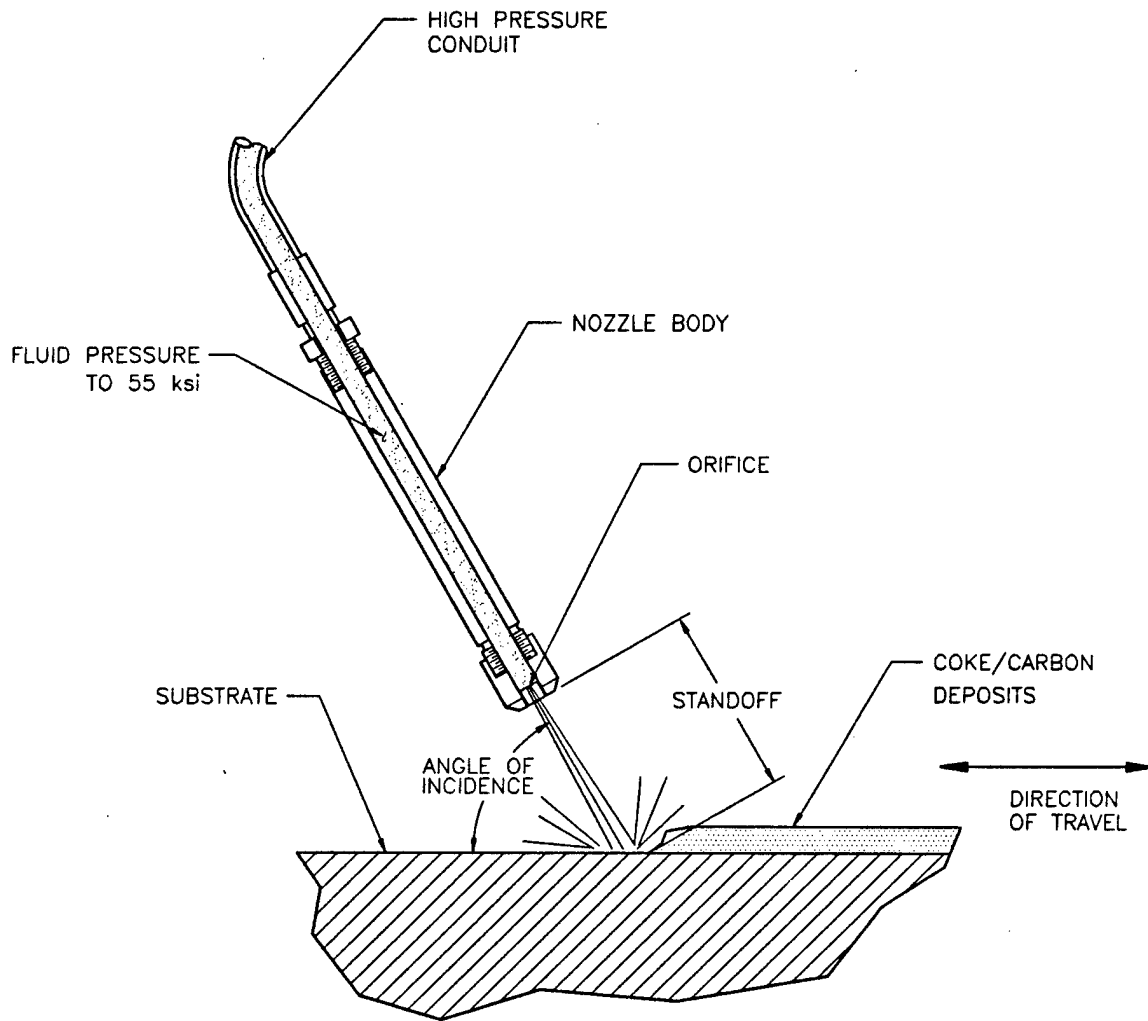

Figure 10. Waterjet Cleaning Fundamentals

Jet rotation was simulated in early tests by mounting sections of tube samples on a rotary turntable and turning the samples under the robotic nozzle. These tests, using unsplit tube lengths, were useful in establishing a basic understanding of the need for jet rotation and yielded preliminary data relating nozzle rotation and nozzle translation.

Process development tests are documented in Table 1. The results of those tests are described next.

The Performance of Round Jets

Round waterjets are characterized by extremely high-energy density. At 55,000 psi, round waterjets deliver approximately 285,000 horsepower per square inch in a perpendicular impact. The dynamic impact of the jet water can cause local brittle failure of target materials. Also, the stagnation pressure of the UHP jet is often high enough to cause ductile-regime material removal as the target yields. And finally, the high water particle velocity can remove material in an erosive manner.

Both conventional and PASER-type round jets were studied using the setup illustrated in Figure 11. Conventional waterjets have a sharp-edged orifice at the bottom end of a settling chamber at least 100 orifice diameters long and 10 orifice diameters ID. The standoff distance is the distance from the orifice to the workpiece, and it can be as small as 0.06 inch. A PASER nozzle is characterized by the existence of a tubular extension after the orifice, which itself can be 100 orifice diameters long and 2 to 4 diameters ID. The purpose of this extension, in the case of a plain waterjet, is to enhance jet dispersion and cavitation.

With high enough pressure, round jets were able to cut and remove any coke deposits. Industrial ultra-high pressure to 55,000 psi could cut any of the test deposits and could be controlled (incidence angle and traverse rate) to have no effect on the tube material. The limitation of round jets was the small size of the jet stream, which in many cases only removed deposits directly under it. This limitation led to fan jet trials, which proved much superior in this regard. It was determined, however, that round UHP jets did have an important role in clearing carbon blockages and opening severely restricted tubes where maximum energy density is necessary.

Varying Incidence Angle

Incidence angles, defined as the angle between the jet and the tube axis, were studied between 0 and 90 degrees (perpendicular). Performance of the round jets at angles between 45 and 90 degrees, especially at higher fluid pressures, seems approximately equal. With a 5-degree incidence angle, jet energy appears much diminished. At the highest UHP fluid pressures, tube etching was possible at low traverse rates. This is consistent with previous UHP industry experience, as these jets are powerful enough to cut thin sheets of weaker alloys. At higher traverse rates, tube material removal is not seen, and the process is not highly sensitive to small fluctuations in speed. The effective surface speed is a combination of rotational and translational motions and can thus be kept high at low traverse rates by rapidly spinning the nozzle.

Process Sensitivity to Pressure and Flow

Jet pressures were studied between 5 and 50 ksi. The lowest pressures, between 5 and 15 ksi, were investigated knowing that commercially available flexible hose could be used as a conduit at those pressures. Also, this is within the pressure range of relatively low-cost duplex and triplex plunger pumps that are manufactured in high volumes by companies such as Cat Pumps and Giant Pumps.

Jetscan Process Development										
Jet Type	Orifice Dia. (inch)	Pressure (#si)	Translation (ipm)	Rotation (rpm)	Angle (from axis) (degrees)	No. of Passes	Sample	Effect on Carbon	Effect on Substrate	
Round	0.003	50	10	0	90	1	Volks	Removed Under Jet	Etched Under Jet	
		25	10	0	90	1	Volks	Removed Under Jet	Etched Under Jet	
		5	10	0	90	1	Volks	Removed a Layer	No Contact	
		10	10	0	90	1	Volks	More/Deeper Layer	No Contact	
		15	10	0	90	1	Volks	More/Deeper Layer	No Contact	
Fan		20	10	0	90	1	Volks	Removed	None	
		20	10	0	90	2	Volks	Removed	Etched Substrate	
		(1.75 gpm)	50	100	0	90	1	Volks	Removed	Etched
		40	100	0	90	1	Volks	Removed	Etched	
		(1.75 gpm)	50	0	100	0	30 Sec Dwell?	Volks	Left Some of Deposit	Removed Some (Rusty)
		(1.75 gpm)	50	0	100	0	30 Sec Dwell?	F100	Removed 100%, 2" Deep	None
Paser	.010/.030	50	1	50	85	1	Volks	Removed Layer, Not Thru	None	
		50	1	100	85	1	Volks	Removed Shallower Layer	None	
Round	0.009	50	5	200	45	1	F100	Removed Under Jet	Etched Under Jet	
		25	5	200	45	1	F100	Removed Under Jet	None	
		5	5	200	5	1	F100	Left Some of Deposit	None	
		4	5	200	5	1	F100	Left Much of Deposit	None	
Fan		4	0	200	0	60 Sec Dwell	F100	Little to None	None	
		25	0	200	0	60 Sec Dwell	F100	Clean 2.5" Deep	None	

Table 1. Test Matrix for Cleaning Process Development

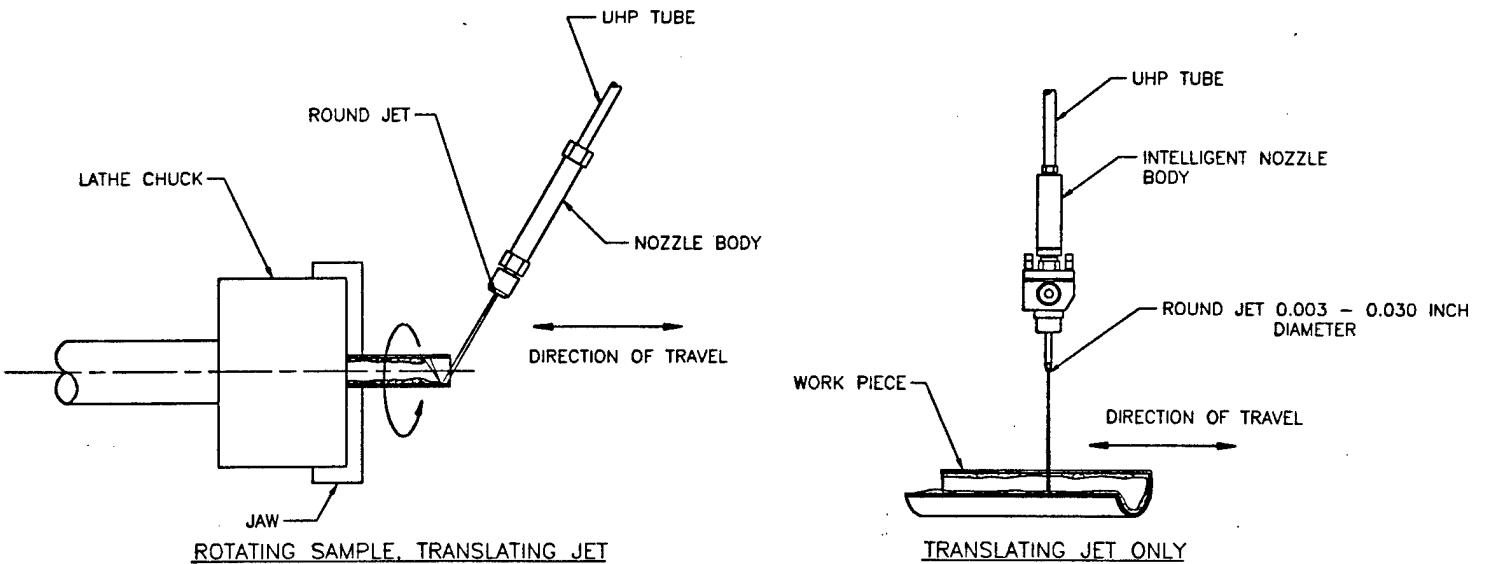

Figure 11. UHP Waterjet Process Development - Round Jets

Pressures between 20 and 30 ksi were investigated knowing that custom small-diameter flexible hoses could likely be justified if suitable cleaning were achieved. Many UHP pump manufacturers, such as Flow International Inc., Ingersoll Rand Corp., National Liquid Blasters Corp., and Butterworth Inc., manufacture UHP pumps specifically for this pressure range, although the cost for such pumps is similar to the cost for typical UHP 55-ksi pumps. Those that make UHP 55-ksi pumps generally note that pump life can be greatly increased by operating at this lower pressure.

The highest pressures were tested knowing that there would be cases where very heavy and hard deposits would require maximum power for unblocking and clearing. These pressures, to 55 ksi, are the highest standard industrial jet pressures. Pumps are readily available for continuous water pumping at such pressure. Flexible hoses are also available, although they tend to be much too big and stiff for tube cleaning in this application. As will be discussed, flexible metal hypodermic tubing was successfully demonstrated as a possible candidate for a 55-ksi flexible conduit.

Results of these tests showed that pressures below 20 ksi do not appear to damage the tube wall, while pressures above, given particular combinations of incidence angle and traverse speed, can etch the stainless steel as it removes the carbon deposit. The flow rate in all tests was kept below 2 gpm by careful selection of the orifice size and water pressure.

Benefits of Rotary and Translational Motion, and Dwell

Relative motion between the jets and the tube material is provided by the superposition of rotation and translation. This serves two functions; prevention of tube damage and the facilitation of complete cleaning.

At maximum UHP jet pressures, effective jet motion relative to the tube at velocities around 200 surface inches per minute were found to prevent tube wall etching while still removing the carbon deposits. This motion could be simple translation at 200 ipm or a combination of translation and rotation. With the tubes approximately 0.563 inch in diameter, nozzle rotation at 100 rpm provided a similar effective motion.

Both the fan jets and round jets are characterized by a specific effective cleaning width per pass. Clearly, the fan jet is much wider than the round jet. The cleaning width is a function of standoff distance, although a weak function with the round jets. Relative motion between the round and fan jet was designed to overlap subsequent cleaning paths slightly. The overlap was only used as assurance of complete coverage. As an example, with a round jet nozzle spinning at 60 rpm and two opposing orifices of 0.013 inch size, a translation of 1.5 ipm resulted in complete surface coverage. At the highest pressures, multiple passes were not found to be necessary for complete coke removal.

Dwell was used with fan jets and lower-pressure round jets to enhance tube wall scouring. Typically, a dwell in translation was utilized with continuous nozzle rotation. It was found that fan jets, directed axially down the centerline of the tubes, particularly required this dwell to completely clean the wall for some axial distance. This dwell effectively allowed multiple passes over the tube surface. With the wide contact area of a fan jet, a very slow translational speed would have likely provided similar results. A traverse dwell is a possibility for the low-pressure process discussed further.

The Performance of Fan Jets

Fan jets were tested, as shown in Figure 12 and Figure 13. The fan jets were found to offer much more effective coke removal, with little chance of tube damage, than the round jets in most conditions. For Phase I testing, a fan jet was selected that flowed 1.75 gpm at 50 ksi with an effective orifice size of

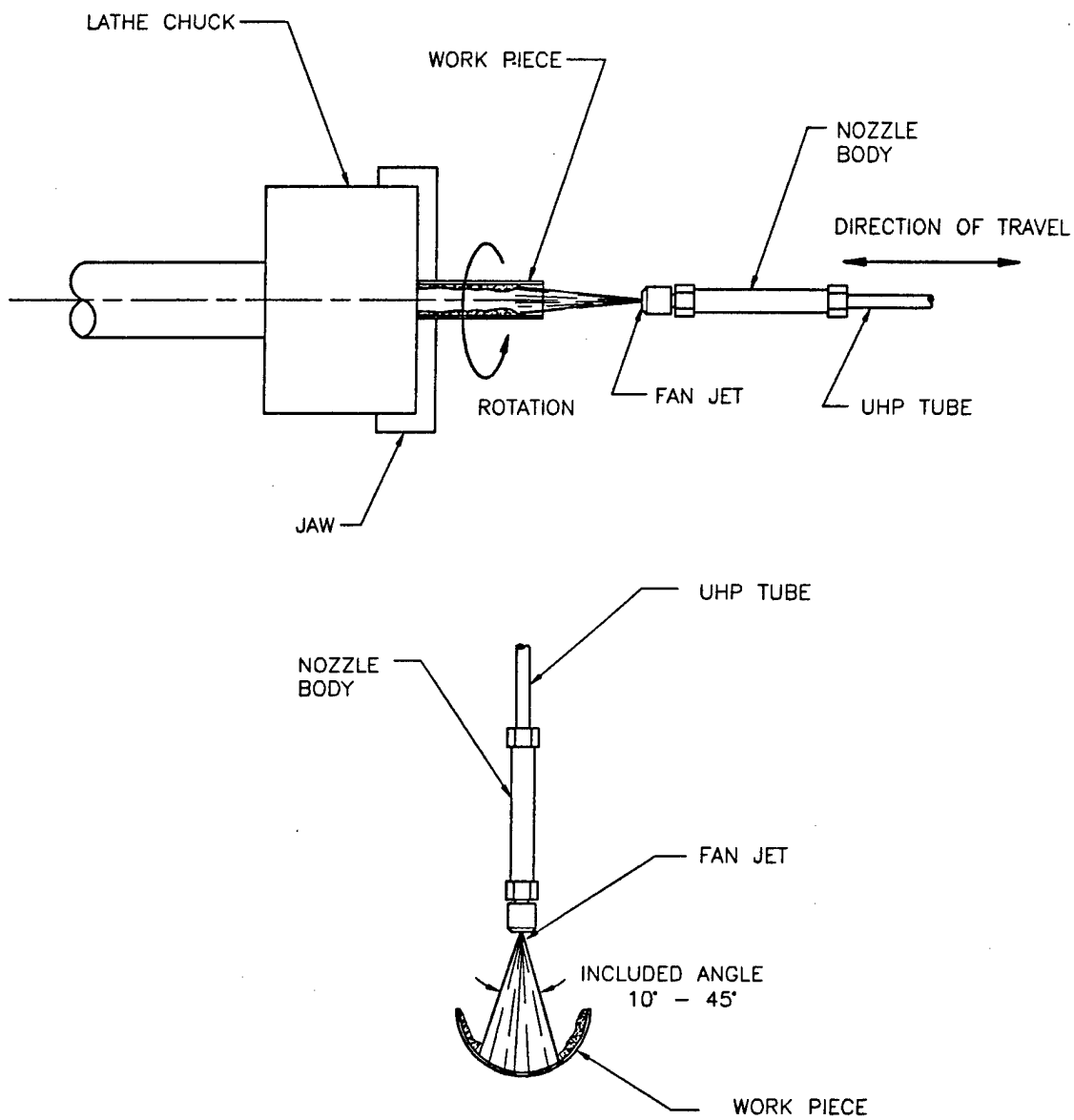

Figure 12. UHP Waterjet Process Development - Fan Jets

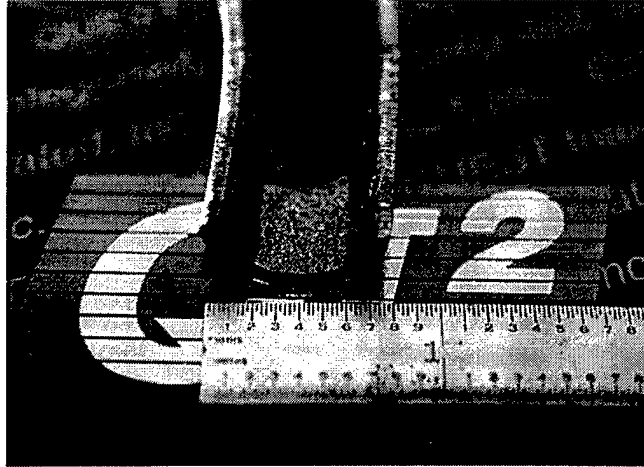

Figure 13. Example of Heavy Coke Removal Via Fan Jet (Volkswagen Tube)

0.019 inch. This was the largest size that would be used in a UHP application being driven by a single typical (Flow International 20XD) pump. A standoff distance on the order of 0.25 to 1.0 inch was identified as offering the widest coverage with the least loss of effectiveness. Shallow incidence angles were required to achieve this standoff. When directed axially down a tube and rotated about the tube centerline, fan jets were uniquely effective for clearing blockages, cleaning heavy deposits, and cleaning light deposits.

Energy Distribution and The Importance of Incidence Angle

The cleaning performance of fan jets seemed largely insensitive to incidence angle. Given the typical 15- to 45-degree spread of fan jets, any tube material within the jet band was cleaned without strong regard for whether it was in the middle of the band or toward the sides. With characteristically more power distributed towards the extreme edges of the fan jet, medium and low incidence angles were still effective.

Flexible Wand and Nozzle Development

With the above process development task completed, initial jet and motion parameters were defined well enough to proceed with hardware development. It was known that there were positive attributes associated with low-pressure as well as UHP jetting in terms of cleaning effectiveness, system durability, and protection of the tube material. Also, it was known that standoff concerns and jet characteristics would require a small nozzle head mounted on a flexible conduit wand that could be inserted inside the tube. An investigation of nozzle and wand designs was undertaken to develop and test candidate concepts. Wand nozzle development tests are documented in Table 2. The results of these tests are described below.

Geometric Considerations for Tube Cleaning

Figure 14 illustrates the physical considerations of a flexible wand nozzle for cleaning the inside of curved tubes. The wand conduit needs to have sufficient strength to counteract the reaction forces of the jet(s), which range from 1 lb for a 0.013-inch jet at 5 ksi, to 20 lb for a 0.019-inch jet at 50 ksi. Directing the jets forward, to the side, or back can result in a net tensile, compressive, or neutral load on the conduit.

Jetscan Wand Nozzle Development						
Test Type	Pressure (ksi)	Translation (ipm)	Rotation (rpm)	Comment	Effect on Carbon	Effect on Substrate
Static, Silverbraz	60	0	0	Test Joining Method	N/A	N/A
Static, Hypo Tube	60	0	0	Test Tube Static Strength	N/A	N/A
Bending, Hypo Tube	45*	0*	0	Test Tube Yield, Fatigue, Dynamic Strength	N/A	N/A
Static, Soldered	35*	0	0	Test Joining Method: Failed	N/A	N/A
Static, Flare/Solder	35*	0	0	Test Joining Method: Failed	N/A	N/A
Static, Seal/Collet	60	0	0	Test Joining Method	N/A	N/A
2-Jet Hose	5	0.2	0	Generate Striped Tube for Inspection	Removed Streaks Under Jet	None
	10	0.2	0	Generate Striped Tube for Inspection	Removed Almost All	None
	15	0.2	0	Generate Striped Tube for Inspection	Removed All	None - Slightly Polished
	15	0.2	60		Removed All	Cleaned to High Shine
	15	0.4	60		Removed All	Cleaned to High Shine
4-Jet Hose	15	0.4	60	Flow Equal to 2-Jet, More Distributed	Removed	Cleaned to High Shine
	15	0.8	60		Removed	Cleaned to High Shine
2-Jet Hypodermic	55	0.06	60	JHP Jets With 90 deg Incidence Angle	Removed	Etched Spiral Track
	30	0.6	60		Removed Under Jet	Nozzle Rub, Light Scratch
	30	0.4	60		Removed Under Jet	Nozzle Rub, Light Scratch
1-Jet Side Firing	15	0.4	60	Designed for 20-25ksi	Left Some Outside Bend Radius	None
	15	0.25	60		Removed	None

Table 2. Test Matrix for Wand Nozzle Development

ISSUES:

- * HEAD LENGTH AND DIAMETER
- * COKE / CARBON BUILD-UP
- * TUBE ID AND BEND RADIUS
- * CONDUIT OD AND BEND RADIUS
- * THRUST REACTIONS
- * CONDUIT BUCKLING
- * JET PRESSURE
- * TUBE MATERIAL

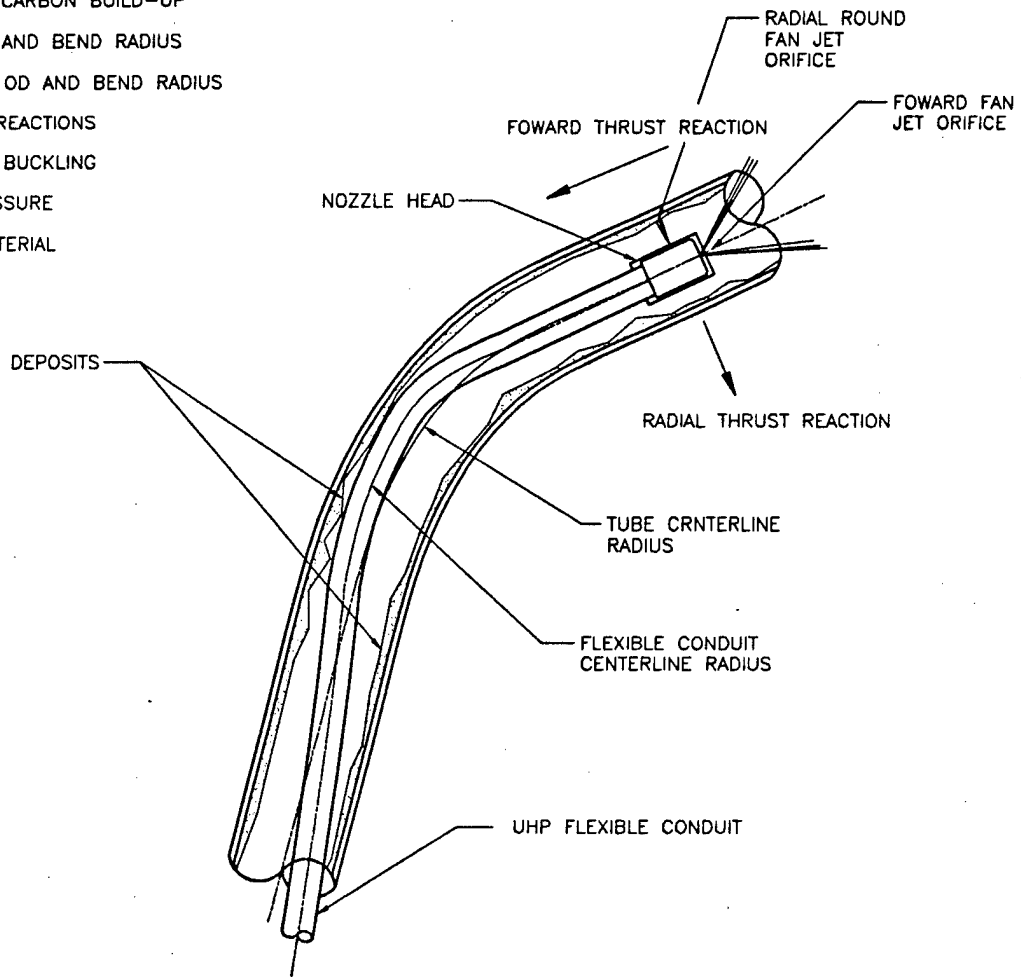

Figure 14. Geometric Considerations for the Wand and Nozzle

The nozzle head and conduit need sufficient flexibility to accommodate any tube bends, with enough fatigue strength to facilitate repeated bending operations. With wand rotation a primary means of rotating the nozzles (since a swiveling nozzle head is often prohibitively large, unreliable, or expensive), the conduit wand can undergo cyclic reverse bending as it passes through tube bends. Thus flexibility and fatigue resistance are both important.

Finally, the wand nozzle must be designed with soft outer surfaces to prevent tube scratching as it is pushed or pulled through. In these Phase I tests, heat-shrink tubing was often used around test nozzles to eliminate the possibility of metal to metal contact. Plastic centralizers, or bushings, may be part of the Phase II wand nozzle design task to more durably serve this same purpose while maintaining better control over orifice standoff.

Hose as a High-Pressure Conduit

As fluid conduits, hoses are typically characterized by high flexibility and low weight. In part of this investigation small-diameter hoses were evaluated as a potential fluid conduit.

Diameter/Pressure/Flexibility/End Configurations

High-pressure flexible hoses are typically constructed of multiple layers, with composite designs incorporating combinations of extruded plastic tubes, sewn fabric sleeves, wound reinforcement, and molded covers. The biggest challenge in hose construction is the end connections. Typical connections are either factory-swaged barb fittings or reusable threaded barb fittings. In the case of very small hose sizes (nominally 1/4 inch and smaller), end connections often dictate how small an opening the hose can be passed through or how tight a bend the hose can be pushed through.

For this application, the ideal hose is very small in OD with a high-pressure rating. This is consistent with hose design, as wall stresses decrease with size and high-pressure ratings are thus feasible. In this Phase I study, several commercially available hoses were acquired and evaluated for applicability. These are illustrated, with Phase I test nozzle heads, in Figure 15.

DH400 Flexible Tube

DH Instruments offers a Kevlar-reinforced hose of unmatched size and strength. This three-ply (polyamide-fabric braid-polyamide) uses swaged stainless steel ends to achieve a burst strength of 27,000 psi in a package only 0.19-inch OD.

For Phase I testing, this hose was received with a standard 1/8-inch tube end fitting. A 90-degree side-firing nozzle was designed that pressed into the end fitting (after being shortened) and was retained with a custom press-fit outer sleeve.

Rogan and Shanley Polyflex 1000 Hose

Rogan and Shanley, Inc., offers two versions of a 1000 series hose. The 1003K hose comes with factory swaged ends and is 0.27-inch OD with a 20,300-psi burst pressure. This hose is made of a nylon core wrapped by one braided layer of high-tensile, brass-plated steel wire and covered with a polyurethane outer cover. Sold as a hydraulic hose, it was decided after evaluation to be inferior in this application to the model 1003MK hose.

ROGAN AND SHANLEY
 1003MK: 9.28 ksi / 23 ksi BURST, WORKING PRESSURE
 1.17 INCH MIN. BEND RADIUS

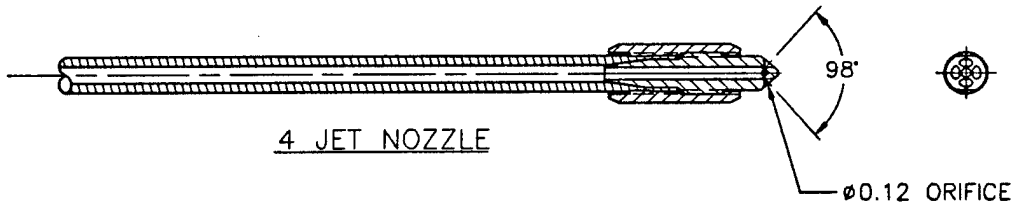
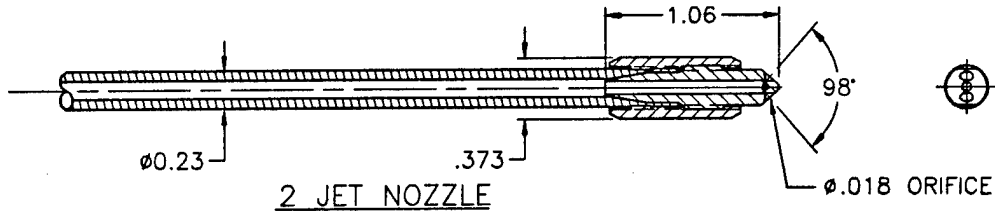

ROGAN AND SHANLEY
 1003K: 8.0 ksi / 20 ksi BURST
 1.17 INCH MIN. BEND RADIUS

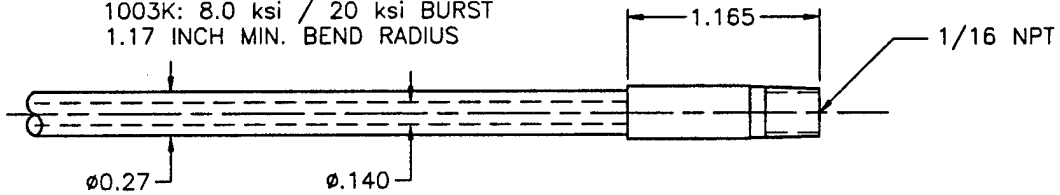

DH INSTRUMENTS
 DH400: 6.0 ksi / 27 ksi BURST

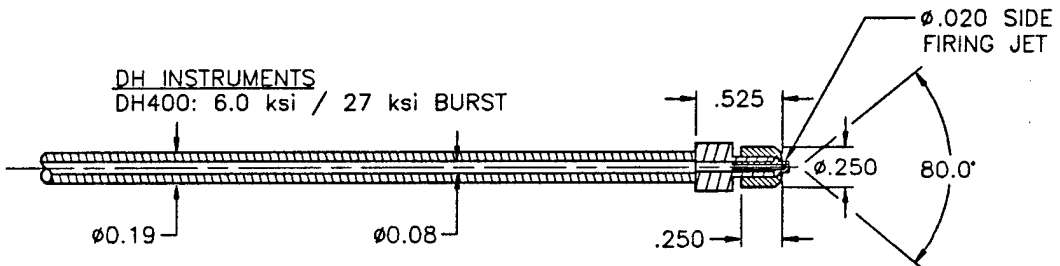

Figure 15. Flexible Hose as Flexible Conduit

The 1003MK hose is a similar hose with a single, braided layer of aramid fiber reinforcement. With an OD of 0.23 inch, this hose has reusable ends and is rated with a burst strength of 23,200 psi. For this investigation, custom nozzle ends were designed and built with two and four jets, angled outward at 49 degrees off axis.

Flexible Tubing for UHP Cleaning

For higher-pressure work (to 55 ksi), flexible hose is not feasible, and an alternative conduit design was necessary. Phase I included a conceptual design period in which many different ideas were evaluated for suitability for this task. A multisegmented articulating conduit was rejected due to excessive fabrication costs. The most promising design was a very small-diameter metal tubular conduit.

Metal tubes for UHP fluid are used extensively in the industry, in sizes down to 1/4-inch OD. These tubes, however, are manufactured from work-hardened 304 or 316 stainless steel and have wall thicknesses one third their OD. This makes them very rigid. For this application, a tube as small as 0.020 inch was desired. A tube this small would not require thick walls to contain the pressure and could thus be very flexible, even at pressure.

MP35N Hypodermic Tubing

MP35N is a nickel-cobalt alloy characterized by ultra-high strength, toughness, ductility, and outstanding corrosion resistance. In the work-hardened and aged condition, this alloy has one of the highest strength levels of any metal, and its other qualities make it exceptionally well suited for this application. Manufactured exclusively by the Latrobe Steel Co., it is drawn into hypodermic tubing and used extensively in the medical industry. For this Phase I investigation, small samples of small OD tubing were procured and tested as candidate UHP conduits.

Material Properties

MP35N achieves strength through a combination of work hardening and aging. As hypodermic tubing, the degree of reduction beyond an annealing stage establishes the amount of work hardening in the finished product. Aging is done following work hardening and is a simple four-hour air furnace soak at 1100 degrees Fahrenheit followed by air cooling. Annealed, this alloy has a 55-ksi yield strength. Fully work-hardened and aged, MP35N has a yield strength of 285 ksi, retaining 9-percent elongation.

Design Stresses

The tubing sample acquired for this study was 0.042-inch OD and 0.0285-inch ID for a wall thickness of 0.0065 inch. The ratio of wall thickness to OD was 1/6, much less than the 1/3 industry standard for larger UHP piping. At 55 ksi, the theoretical maximum hoop stress is 150 ksi. This is well below the nominal tube failure stress.

With small-diameter tubing, pressure drop is an issue. Assuming a 0.010-inch orifice, the water flow rate is 0.46 gpm, with a Reynold's number of 51,000. Flow is thus turbulent. Using a friction factor analysis, pressure drop through this tubing would be approximately 800 psi/ft. With a pump pressure of 55,000 psi, the drop through as much as 10 feet of this tubing would still be acceptable. Even with the full output of a typical UHP pump (2 gpm from a Flow International 20XD) passing through this small tube, the pressure drop (14,336 psi/ft) would be acceptable for shorter tube lengths.

Ductility/Fatigue Capacities

MP35N has excellent fatigue properties. The published endurance limit in a tension-tension fatigue test is 140 ksi, and in a Moore reverse bending test it is 90 ksi. Given the available tube for this feasibility study, the theoretical stress levels at 55-ksi fluid pressures were not prohibitively higher than these limits. A tube drawn specifically for this application could be designed below the endurance limit. Even with the tube used for Phase I, dropping the pressure by only 10 ksi could enable infinite lifetime.

Joining Techniques

Having identified and acquired a candidate tube for the conduit design, preliminary designs were generated and tested for packaging this conduit for tube cleaning (see Figure 16). The critical issue to resolve was simply a question of terminating the hypodermic tubing. In general, the tubing would have to be joined and sealed at either end in connections to either a nozzle head or a plumbing fitting.

Silver Brazing

Silver brazing was the first technique used to assemble a hypodermic wand nozzle. For test purposes, only minimum-length tubes were used to preserve the limited amount of this material given the destructive nature of tests to failure.

The silver braze used was Andy Harmon #505 silver, following Andy Harmon type "B" black flux. This high-strength brazing system was applied at 1150 degrees Fahrenheit, which is a temperature at which MP35N, and the 15-5 PH stainless nozzle/fitting components age and begin to anneal. In an attempt to minimize weakening effects, the silver brazing was done before the aging of the entire assembly. This resulted in a wand made of maximum strength MP35N and medium strength/hardness 15-5 H1150 stainless (not hard enough for long-term nozzle life). The exact nature of the heat effected zones around the brazing was unknown.

In testing this assembly performed well, but eventually failed during bending tests at pressure. The failure was near a brazed joint and appeared to be a brittle tensile failure. Fatigue could have been a factor, however, it is suspected that heat effects from the high-temperature brazing operation weakened the tubing.

Soldering

To eliminate the possibility of excessive heat damage, low-temperature silver solder was investigated as a means for joining and sealing MP35N tubing.

After a solvent clean, the joint material was soaked in acetone and fluxed with a typical acid flux. Andy Harmon #430 silver solder was applied to the joint using a preloading technique. Silver was wrapped around the interface, which was heated away from the tubing to minimize local heating in excess of the 430 degrees Fahrenheit required for this joint.

In tests, the soldered joint typically failed at pressures between 30 to 40 ksi. It appeared that the solder didn't have enough strength/adhesion to resist the fluid pressures. Failures were either catastrophic separation of the joint or pinhole loss of sealing.

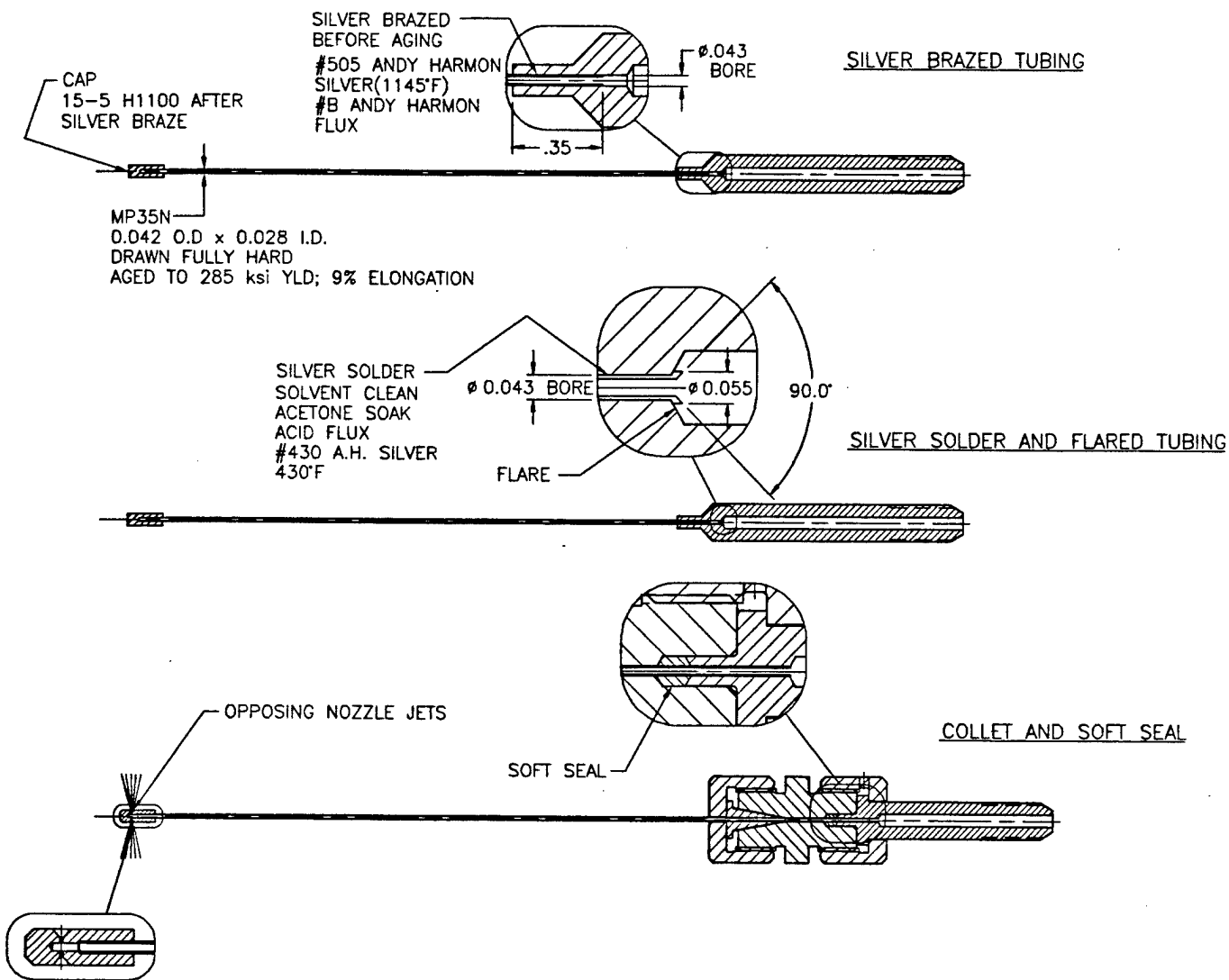

Figure 16. Rigid Tubing as Flexible Conduit

Flaring and Soldering

To address the inherent weakness of the soldered joint, a pressure-energized design was tested incorporating a 90-degree tube flare to mechanically lock the interface together. In this case, solder was used only as a sealing agent and to keep the joint tight at fluid pressures below the energizing pressure threshold.

This joint design failed when pinholes developed through the solder, and the seal was lost. It appeared the tubing was too small to uniformly flare, and the soldered connection was too difficult to make tight enough to prevent pinholing. The failure of this connection, and the desire to avoid high-temperature assembly operations, led to the collet and soft seal design.

Collet and Soft Seal

Success was finally achieved with a mechanical collet and soft seal joint. This connection utilized an aluminum-bronze #642 collet to clamp the tube OD, wedged between the 15-5 stainless steel collet body and nut. A polyurethane soft seal was machined in the opposite end of the body, and the hypodermic tubing was compressed beneath the seal and a nipple adapter by another nut. This hardware quickly and reliably held and sealed the tubing in repeated tests.

For cleaning tests and demonstrations, a simple nozzle head was silver brazed to the end of a length of hypodermic tubing, which was plumbed to the UHP water supply using this collet/soft seal technique. Multiple tests were completed between 30 to 55 ksi to demonstrate this wand nozzle cleaning straight and curved tube sections. Results in each case were consistent with that noted in the process development task and are discussed further below.

Laser Inspection

The concept for the tubing inspection system is based on the principle of optical triangulation. Although it is a relatively new inspection and measurement technology, the method has been proven in the field to be a reliable and cost-effective means of obtaining high-resolution data regarding the dimensions and condition of tubular surfaces. QUEST has adapted this technology to a wide variety of applications, including the measurement of tubing as small as 0.25 inch ID.

Laser-Based Triangulation Background

The laser-based surface mapping method operates on the principle of optical triangulation. An example of the application of this technology to the inspection of tubes is QUEST's Laser Optic Tube Inspection System (LOTIS™), shown in Figure 17. It was originally designed for the inspection of military marine boilers, and it has been used by the U.S. Navy for regular boiler inspections since 1987. The technology is now being used for nondestructive testing in boilers and heat exchangers in industries such as fossil power generation, petrochemical refining, and pulp and paper processing.

The sensor employs a small solid-state laser transmitter that projects a beam of infrared light (approximately 0.02 inch in diameter) onto the target surface (Figure 18). Receiving optics image this spot of light onto a single-axis lateral-effect photodetector (LEP) (Johnson et al, 1995). Because the transmitting and receiving optics are at different angles, changes in target proximity are converted to lateral movement on the photodetector. For a perfect optical system with a magnification of unity, the displacement of the light spot on the detector is equal to the depth of the pit.



Figure 17. Operation of LOTIS™ Model 400-N

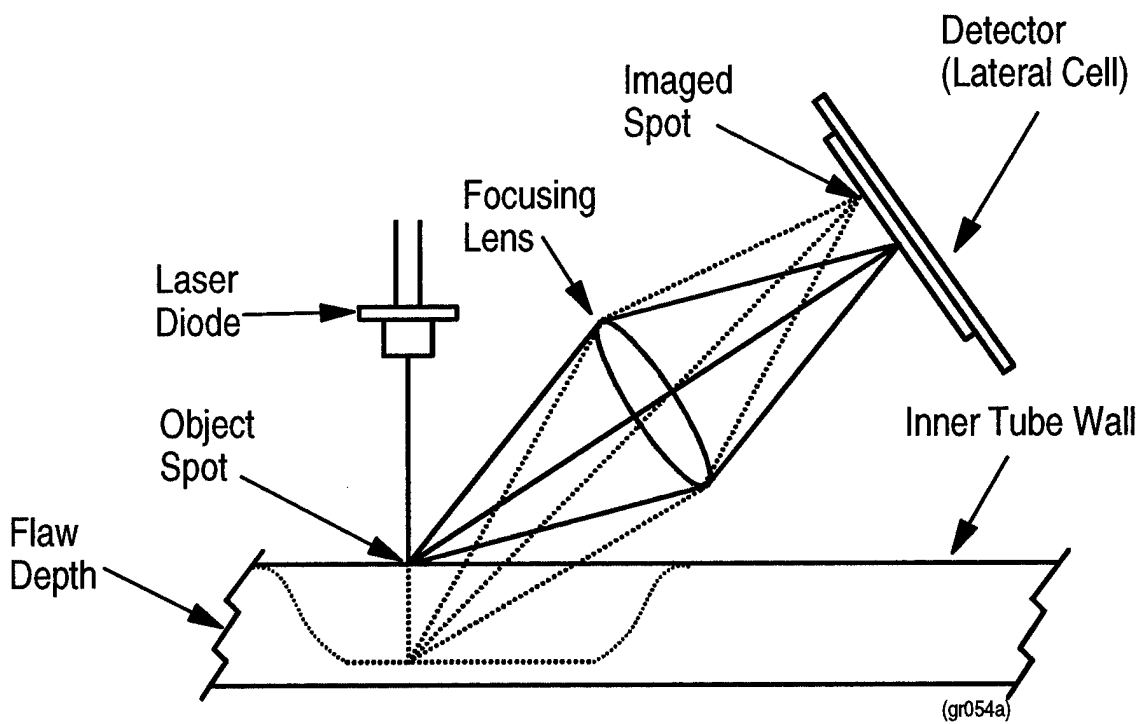

Figure 18. Laser Triangulation

Operation of the linear position photodetector is straightforward. When light strikes this device (Figure 19), photocurrents flow to the anodes at the ends of the detector. These currents are proportional to the position and intensity of the light, and the magnitude of the photocurrents varies linearly as the position of the light changes on the photodetector. The position of the imaged spot x relative to the center of the photodetector is given by

$$x = a \frac{(I_1 - I_2)}{(I_1 + I_2)}$$

where I_1 and I_2 are the two photocurrents and a is a scale factor. By dividing the difference ($I_1 - I_2$) by the sum ($I_1 + I_2$), the effects of variations in received light intensity due to changes in reflectivity are reduced.

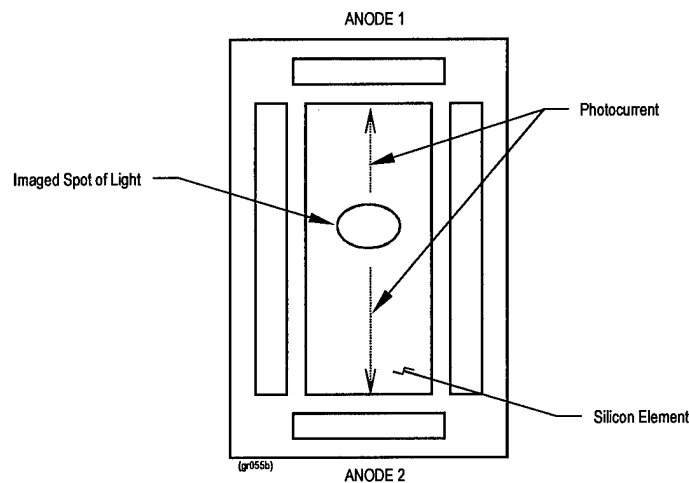

Figure 19. Lateral Effect Photodetector

Calibrating the system for nonlinearities in the detector and reflectivity variations in the material results in precise radius measurements of the inside surface of the tube at each sample point. The sensor rotates as the probe is drawn through the tube, thus creating a helical map of the inside surface (see Figure 20). The system will sample several thousand data points per linear inch of tube; therefore, a very detailed map of the inside surface of a tube can be generated.

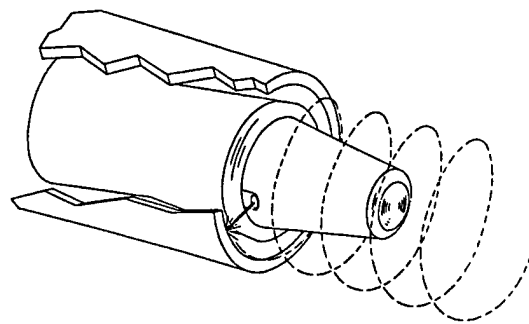

Figure 20. LOTIS Laser Scans a Helical Path Along the Tube Surface

Figures 21 and 22 show examples of the computer-graphic display capabilities that LOTIS provides. Figure 21 shows a Cross-Sectional View (or end view) of a tube with an internal pit. Its depth is measured to 0.037 inch. Figure 22 shows the same flaw in Contour View (plan view).

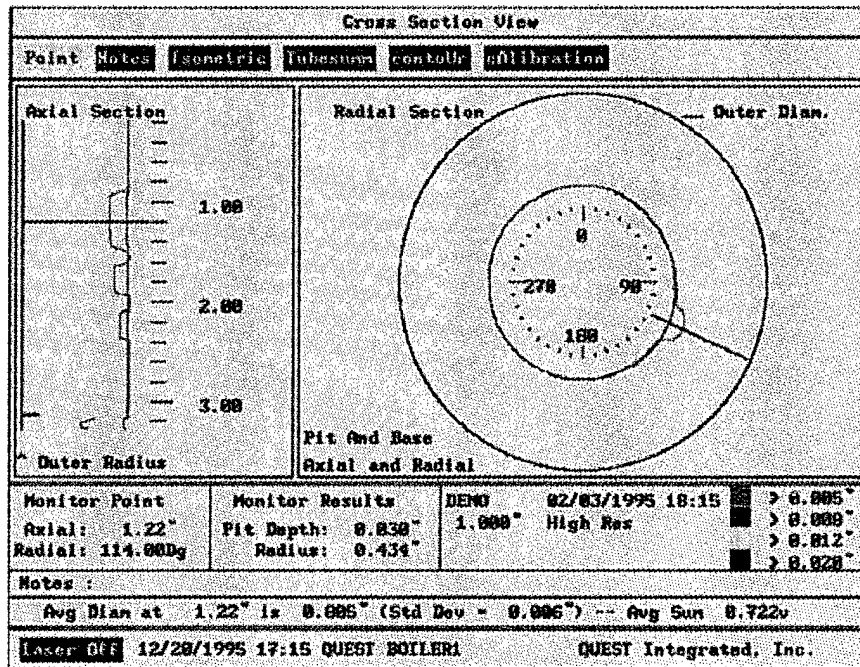

Figure 21. Cross-Sectional View

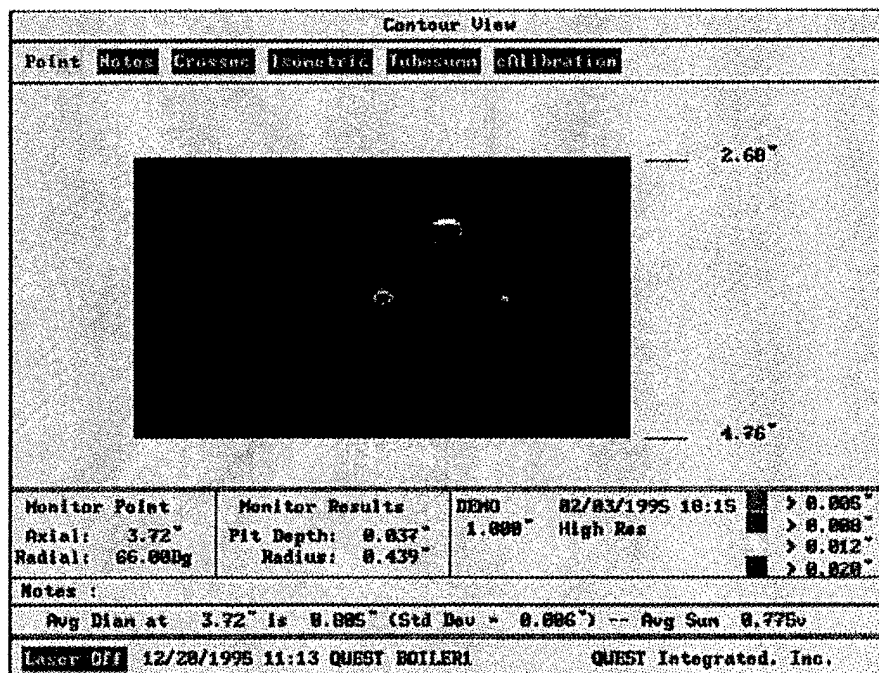

Figure 22. Contour View

Breadboard Evaluation

Upon receipt of the tube samples, the flexible video probe was inserted into the tubes to visually evaluate the condition of the tube surface. It became evident from the outset that tubes that had not been cleaned, but which had significant coke deposits, would be difficult to inspect using strictly optical techniques. This is due to the fact that the coke deposits covered 100% of the inside surface, and the only factor that allows the operator to determine the magnitude of coke deposit is the reduction of inside diameter. However, after the tube had been waterjet cleaned, most surfaces were free of the black, absorptive coke deposit material. The surface tended to be near-pristine and exhibited a significantly higher degree of reflectivity. Tests were conducted using the modified LOTIS probe on tubes that had both clean surfaces and surfaces that contained coke deposits, and the results indicated that the coke deposit could be identified easily by monitoring the reduction in total reflected light.

The second method for evaluating the coked areas is through the use of conventional triangulation methods. In this case, the laser is used to measure the internal diameter of the part. Figure 23 shows an example of LOTIS-based data acquired from a heat exchanger tube. The cursor indicates that the nominal inner radius is 0.976 inch. As shown in Figure 24, by placing the cursor on the feature (in this case a piece of scale on the inner surface), the scale height is shown to be 0.134 inch in height. By using the dimensional measurement capability of a custom laser triangulation probe, scale thickness can easily be ascertained with an accuracy of approximately ± 0.001 to 0.002 inch.

DISCUSSION

This work resulted in the derivation of two possible waterjet process configurations, with one at 15- to 25-ksi and the other at 50- to 55-ksi jet pressure. The lower pressure was demonstrated to remove the carbon with an axial fan jet by dwelling for a period of time incrementally along the tube length. With a tube rotation of 200 rpm, a 30-second dwell cleaned a length 2.5 inches ahead of the nozzle. A high-pressure fan jet did not require the dwell. Rotating round jets at this pressure were effective on thin deposits and for final surface finishing. At the 50-ksi pressure level with the same 200-rpm rotation, an axial jet effectively cleaned the tube surface after two passes traversing at 100 ipm.

Waterjet Cleaning

The primary test setup, consisting of a modified lathe, a computer-controlled linear traverse, and a tube fixture and splash shielding, is shown in Figure 25. The high-pressure water line was fed through the center of the hollow chuck and spindle shaft and connected to a swivel on the back of the machine. Candidate nozzles and flexible wands were connected to the high-pressure line on the front of the machine. The lathe chuck was used to turn the nozzle hardware at speeds between 60 and 200 rpm relative to the tube samples.

Tube samples were mounted as shown in Figure 26. The single-axis linear traverse moved the tube samples forward and backward along the nozzle axis of rotation, enabling tube sections to be cleaned completely.

Figures 27 and 28 show the two- and four-nozzle jet heads developed for use with the Rogan Shanley hose. These hose nozzle designs were rotated and fed through baseline engine tubes, as shown in Figure 29.

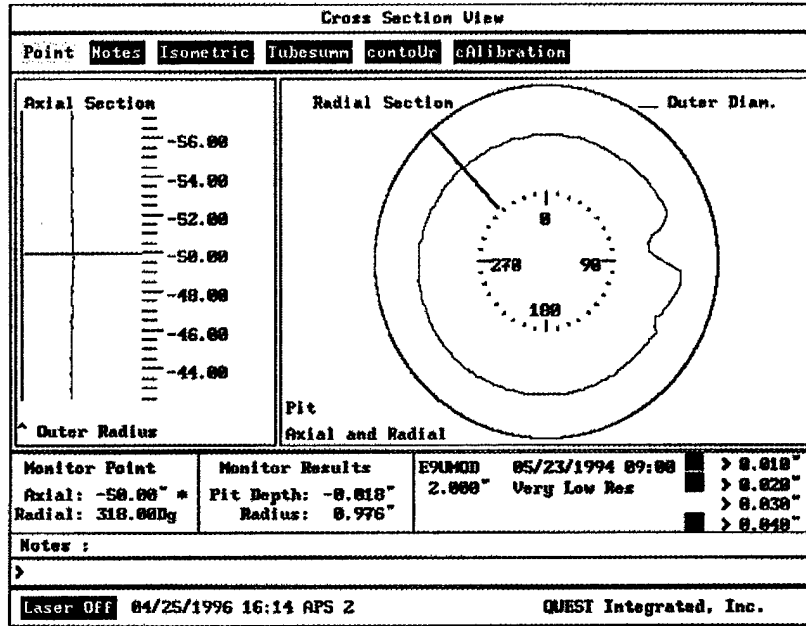

Figure 23. Cross-Sectional View of Tube with ID Scale

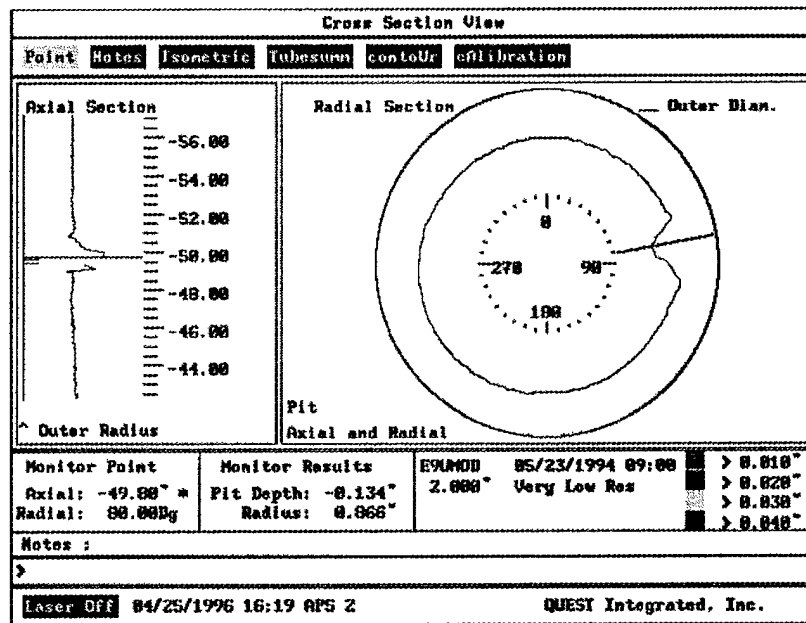

Figure 24. Cross-Sectional View of Tube with ID Scale

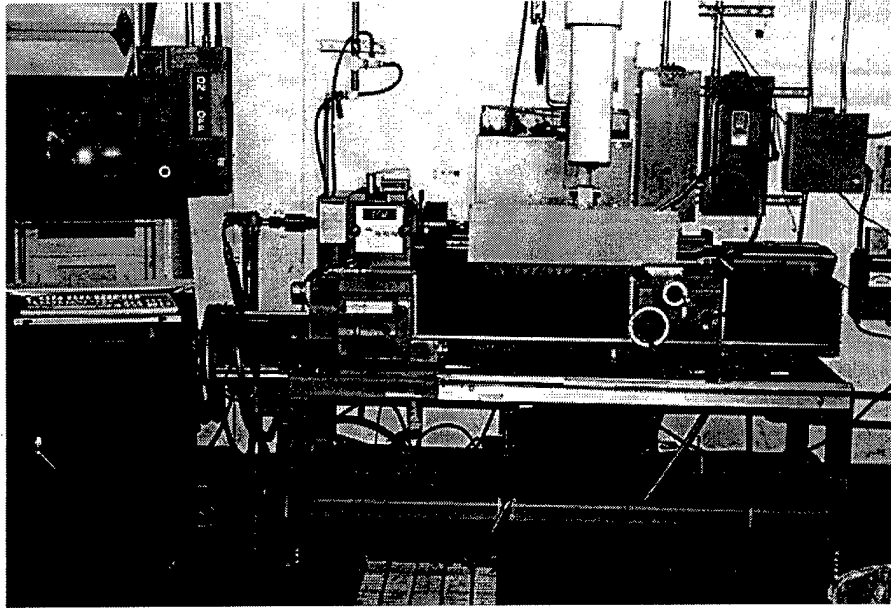

Figure 25. Test Setup for Rotating Waterjet Nozzle and Traversing Tube Sections

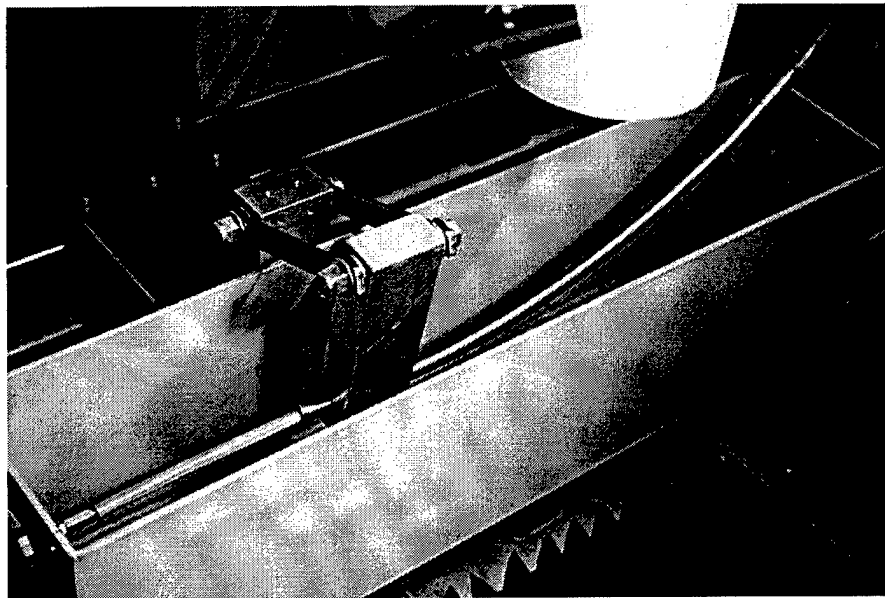

Figure 26. Waterjet Nozzle Inserted in Curved Tube Section for Cleaning

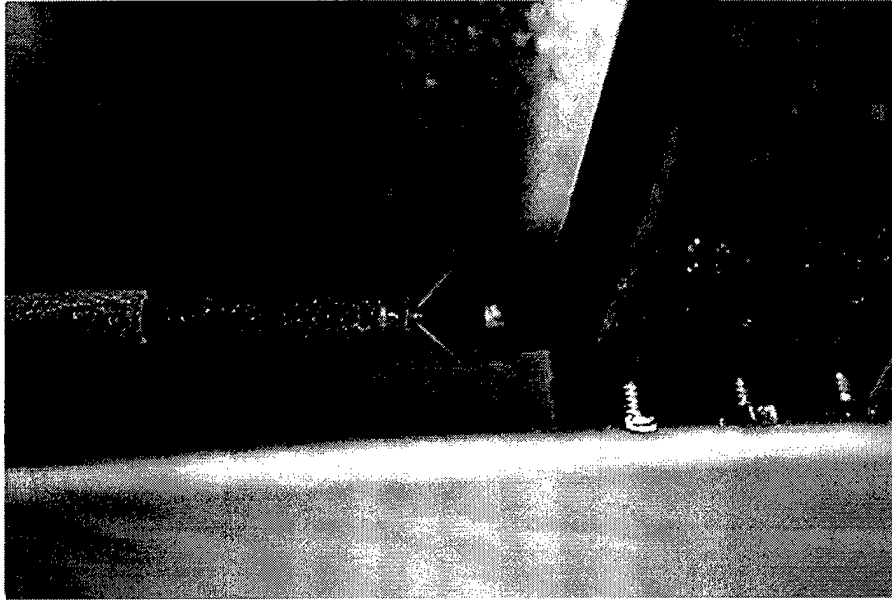

Figure 27. Two-Jet Nozzle Assembly Showing Angled 0.018-Inch Jet Streams

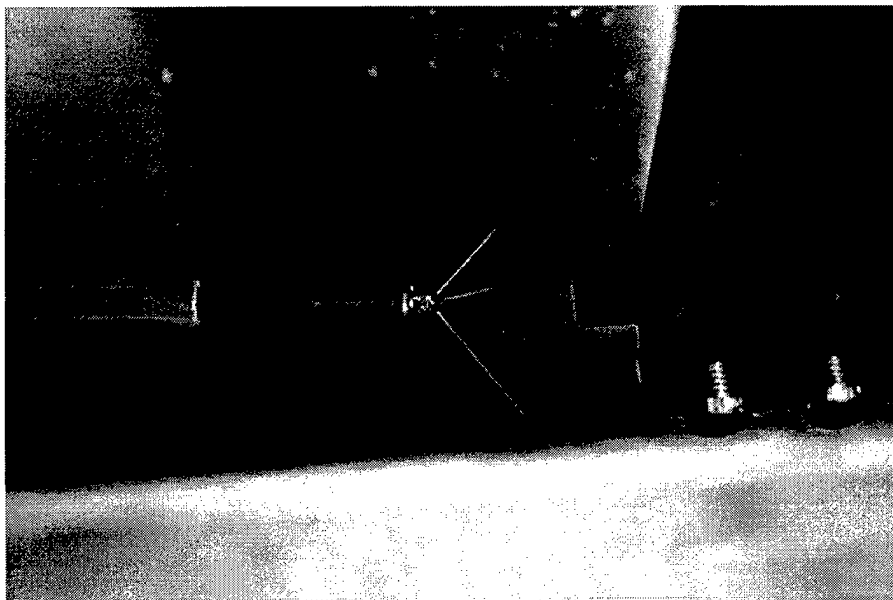

Figure 28. Four-Jet Nozzle Assembly Showing Angled 0.018-Inch Jet Streams

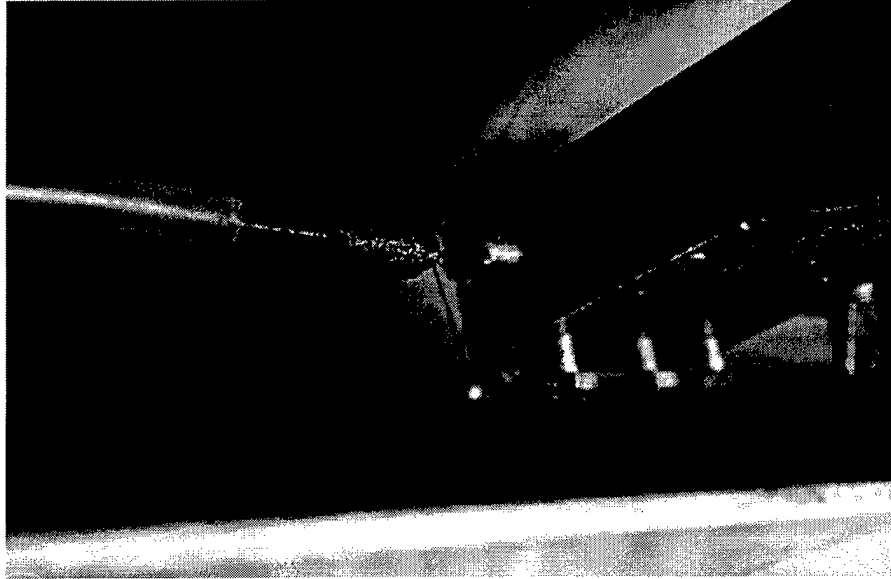

Figure 29. Flexible Hose with Custom Four-Jet Nozzle Entering Actual Jet Engine Tube Section

Figure 30 shows the most-promising candidate UHP flexible wand nozzle, illustrated previously in Figure 16. As assembled for Phase I, wand lengths were limited to 6 to 7 inches to conserve the tubing (of which there was a very limited supply). This technology, however, is fully applicable in lengths of many feet.

Cleaning Effectiveness

Figures 31 and 32 show a baseline tube before and after the cleaning operation to demonstrate waterjet cleaning effectiveness. Shown is the 90-degree elbow end flange, one of the most difficult areas to clean. This was cleaned by inserting a high-pressure waterjet nozzle in from both ends, one at a time. The photographs qualitatively show the excellent cleaning capabilities of high-pressure water.

Microphotographs of uncleaned and cleaned engine manifolds are shown in Figures 33 and 34. These show not only complete decarburization, but also the well-preserved grain structure in the tube wall material. This grain structure is partially evident in the tube before cleaning and is fully exposed after cleaning.

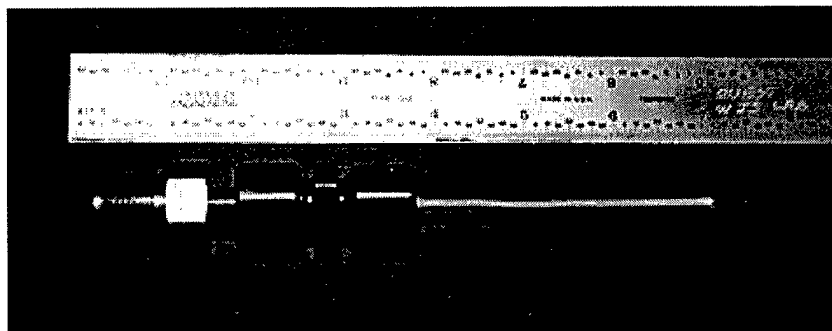

Figure 30. Hypodermic Tubing Wand Nozzle with Collet and Soft Seal

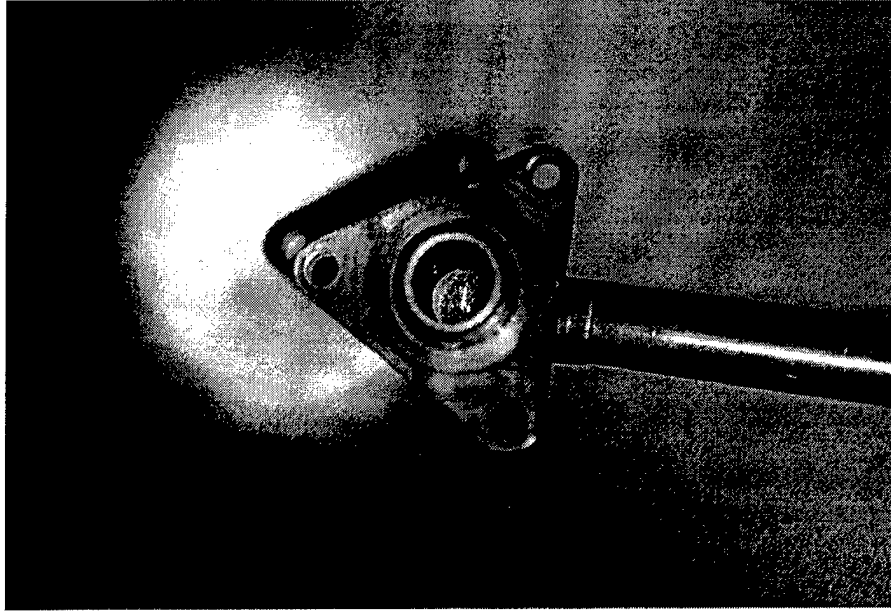

Figure 31. Actual Jet Engine Tube End Before Cleaning with Waterjet

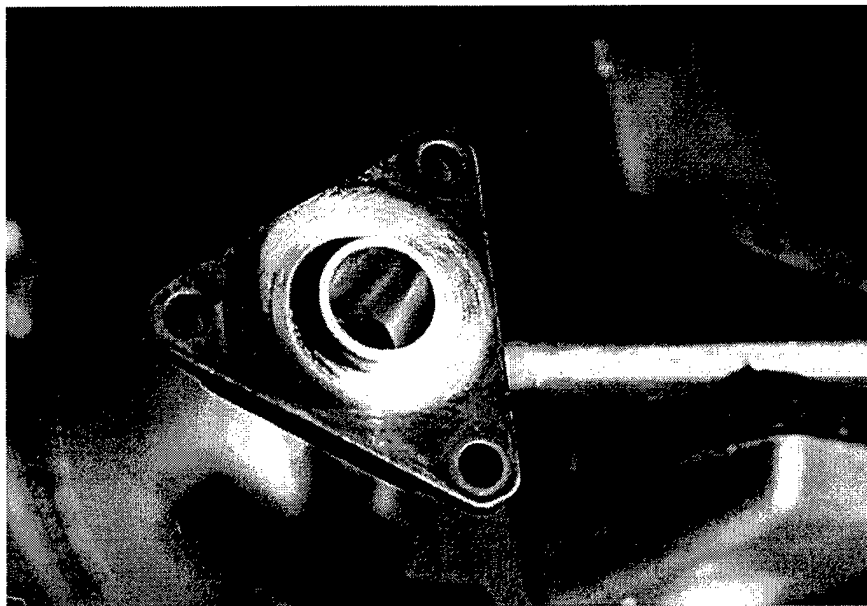

Figure 32. Actual Jet Engine Tube End After Cleaning with Waterjet

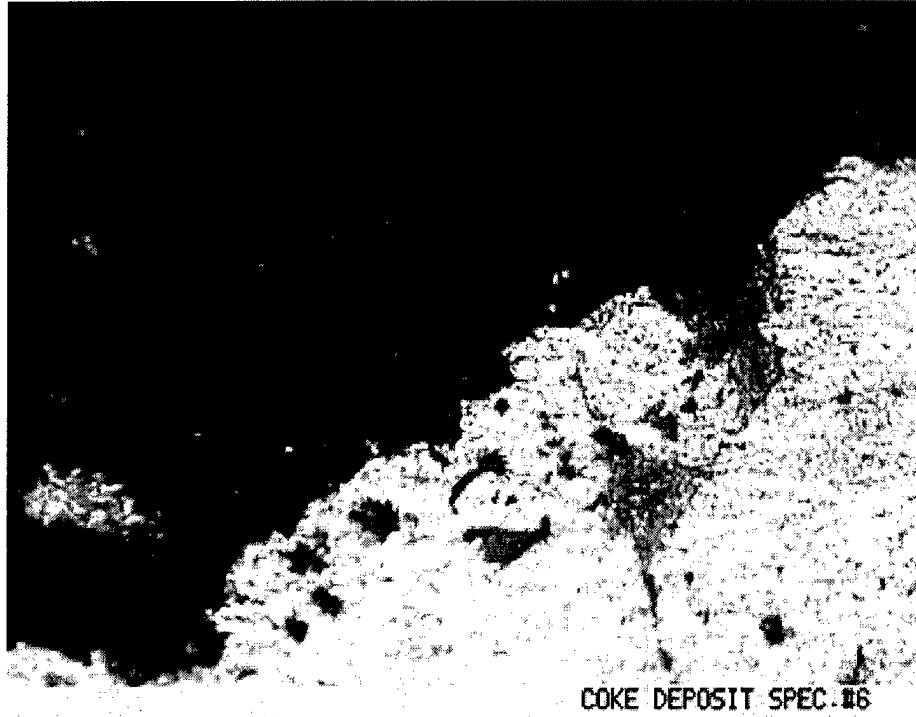

Figure 33. Microphotograph of Coke Deposit on Actual Jet Engine Tube

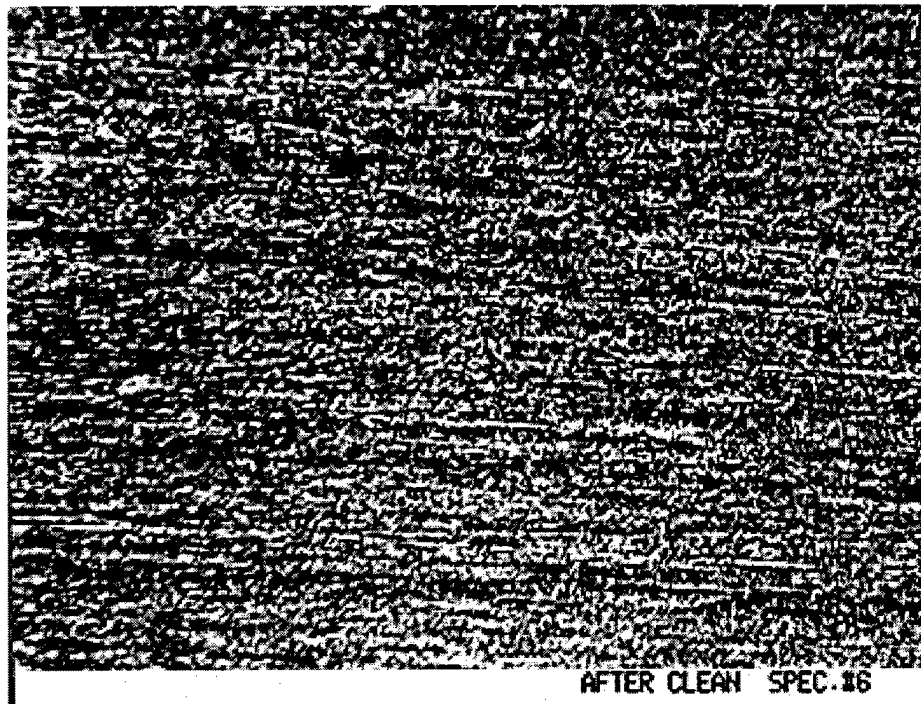

Figure 34. Microphotograph of Jet Engine Tube After Waterjet Coke Removal

The Value Added by UHP

Jet pressures above 30,000 psi were shown to either enable or significantly increase the speed of the removal of heavy coke deposits and blockages. With lighter deposits, lower pressures were often acceptable, although pressures below 15,000 psi were unreliable and often required follow-up with extra passes. For general-purpose use, a system limited to use below 15,000 psi would be unsatisfactory.

Current pump technology operates within three ranges. Common duplex and triplex plunger pumps are manufactured in high quantities and are relatively inexpensive, but are limited to 6 to 10 ksi. Medium UHP plunger or intensifier pumps push operating pressures to 25 to 30 ksi, but cost approximately the same as 55-ksi intensifier pumps. With the demonstrated benefits of jet pressures of 30 to 55 ksi, and given the capability of these pumps to operate as well (with much lower maintenance requirements) at pressures of 15 to 30 ksi, a full-pressure system is best suited for this application.

Conceptual Design of an Industrial System

A conceptual design for the industrial jet tube cleaning system is shown in Figure 35. The system consists of three major components, including the cleaning machine, the UHP pump, and the control console. These components will be connected to each other by piping and control cables. Facility connections will be required for water supply, air supply, and electrical power.

Figure 36 is a block diagram showing the system elements and the basic connections between them and the facility. The I/O (inlet/outlet) adapters and fuel tubes are described as types "A" through "E". This designation assumes that there will be standard designs for fuel tubes that define the dimensions of the tube inlet and outlet.

The system elements are described below.

Key Components

Cleaning Machine

The cleaning machine consists of an enclosure with a fixture for mounting a number of fuel tubes, adapters to connect to both ends of each tube, UHP lances/wands, actuator(s) for rotating and translating the lances/wands, actuator controller drives, and a collection sump for used water and removed coke.

Adapters will be used to connect the various tube ends, at this point assumed to consist of both flanged and swivel nut connections, to the actuator. The adapter has a drain to carry used water and coke to the sump.

Figure 37 shows the tube connected to the adapter and a conceptual design of an actuator for both rotation and translation. A flexible hose design is shown for the lance assembly.

The UHP cleaning assembly is referred to as a "lance" if the nozzle rotates and as a "wand" if the nozzle does not rotate. Conceptual lance and wand designs are shown in Figures 15 and 16. Further process development is necessary to optimize the cleaning assembly design. Design parameters, such as nozzle size, pressure, nozzle type, and nozzle orientation, need to be further tested. Another test goal is determining if lance rotation is necessary. Testing needs to also focus on tube geometry such as bend angle and the presence of elbows (see Figure 14).

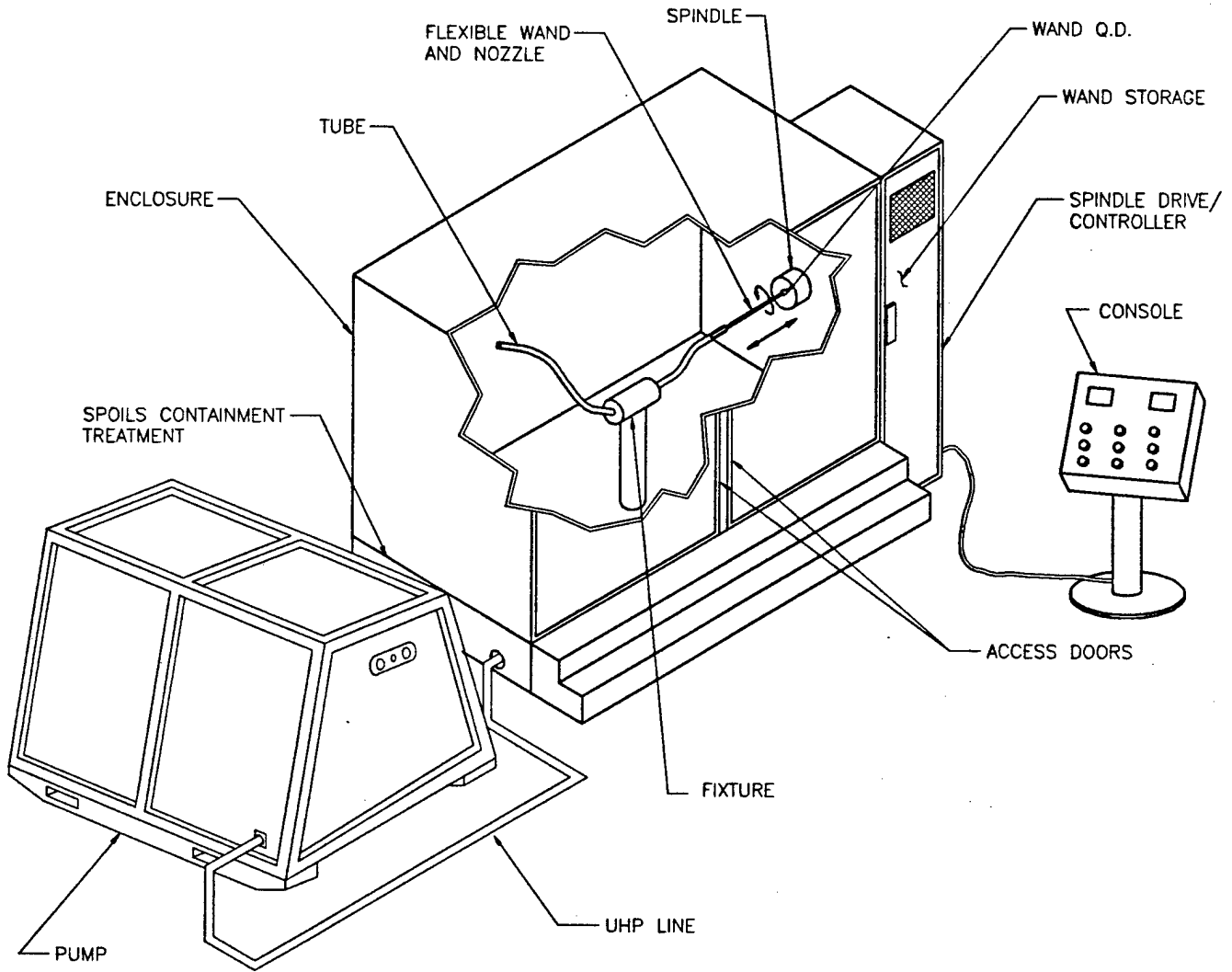

Figure 35. Conceptual UHP Waterjet Tube Cleaning System

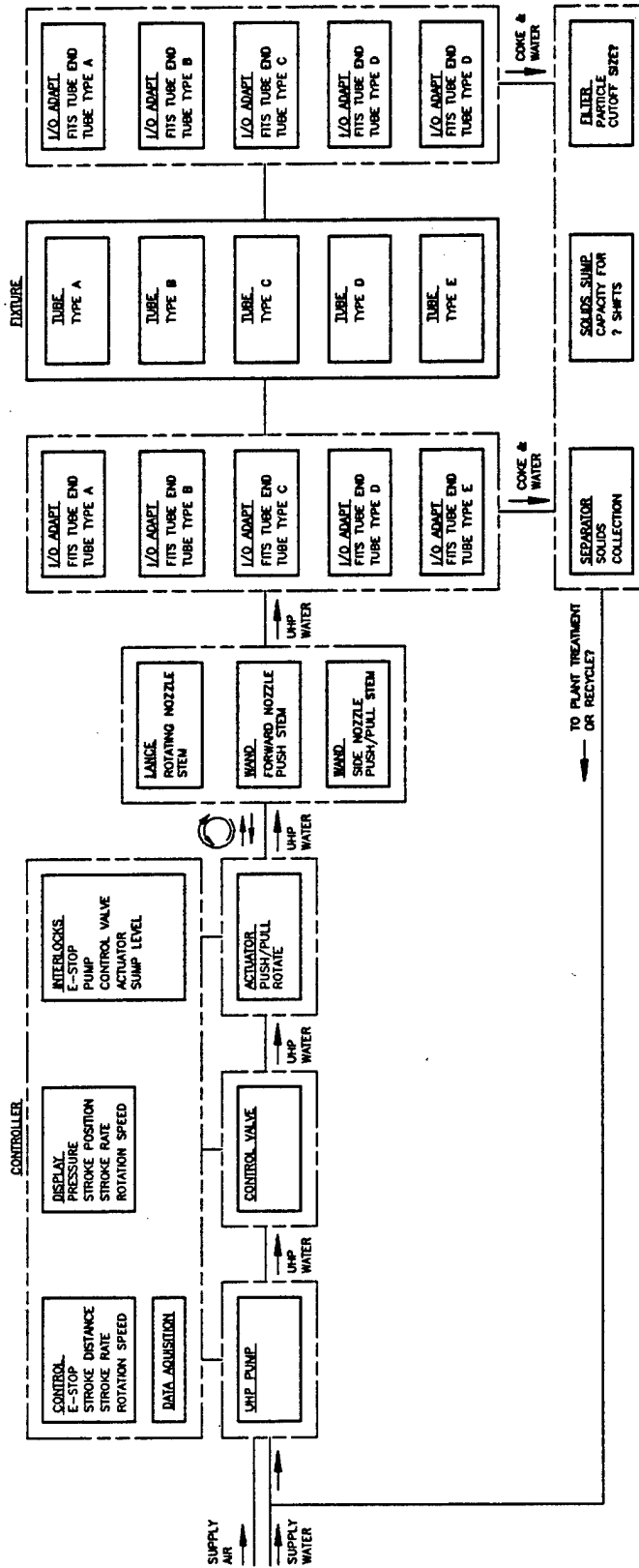

Figure 36. System Block Diagram

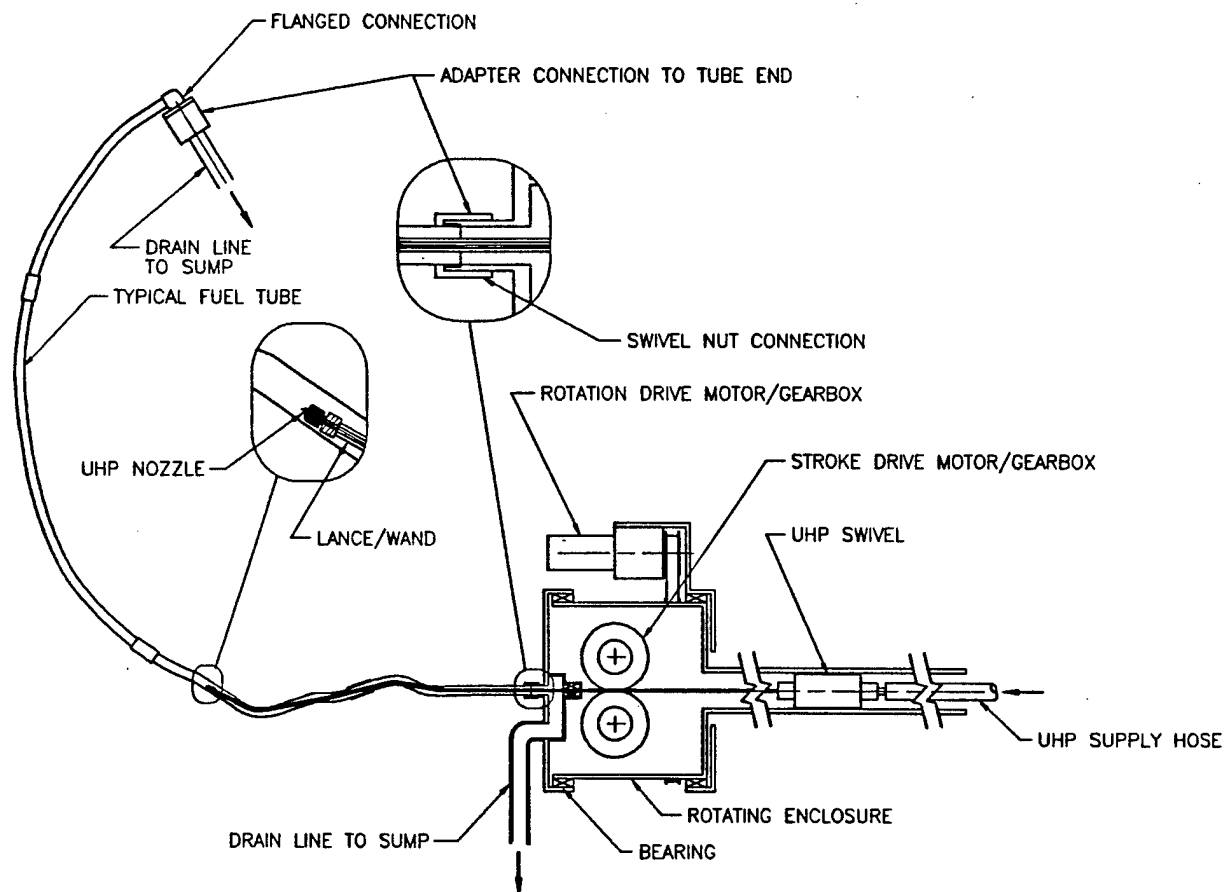

Figure 37. Conceptual Design of Adapter Connections and Stoke/Rotation Drives

Once the cleaning assembly design is optimized, a wear test needs to be conducted to determine the operating life of the lance or wand design. In question would be the orifice life and fatigue life of the UHP conduit (hose or thin tubing), such as the designs presented in Figures 15 and 16.

UHP Pump

The UHP pump (see Figure 38) is an intensifier pump with pressure control adjustable from 5,000 to 55,000 psi. Process development testing will identify the required operating pressure and flow rate, but at this time, the anticipated pressure is approximately 50,000 psi to insure complete coke removal and to minimize the required water quantity. The UHP flow rate has not been determined, but 2 gpm is being used to size a typical system.

Control Console

The control console will be the operator's station during the cleaning cycle. The console is shown as a stand-alone item, but it could be mounted on the outside of the cleaning machine enclosure. The console has controls for setting features such as "Emergency Stop", actuator "Stroke Distance", actuator "Stroke Rate", and actuator "Rotation Speed". The actuator settings, as well as "UHP Pressure", will be displayed. Figure 39 shows a conceptual control panel layout and display.

Interlocks will be provided for emergency stop, UHP pump water inlet pressure, UHP pump oil temperature, actuator overtravel, and sump level. These interlocks are typical for UHP industrial systems. Other interlocks may be added as determined during the system design.

A useful feature of the system would be data acquisition for recording the operating parameters. The operator would log the tube serial number prior to cleaning. Data acquisition would probably require the addition of a microcomputer to the system. The control features previously described could be handled with a programmable controller or microcomputer. Figure 40 shows a typical microcomputer display of a data acquisition system.

Water Treatment

In order to make the system as environmentally friendly as possible, several water treatment scenarios were considered in the conceptual design. As a minimum, a collection sump can be used as a settling chamber prior to pumping the used water to the customer's sewer or to the plant treatment system. With the addition of separating equipment, such as a band filter, the majority of the solids in the water could be removed. If complete treatment is required, then a water recycle system is appropriate, since this contains the water in a closed system and allows for control of the UHP inlet water as well. Figure 41 shows a commercially available closed-loop recycle system.

Dimensional Requirements

The conceptual design of the system should be able to handle different tube sizes. The Phase I baseline tube was used as a good focus for this conceptual design, and Phase I process specifications were adopted. A survey should be conducted to determine what other tube diameters should be considered.

It was assumed that tube hardnesses would be equal to or higher than that of cold-worked stainless steel (70 to 120 ksi tensile).

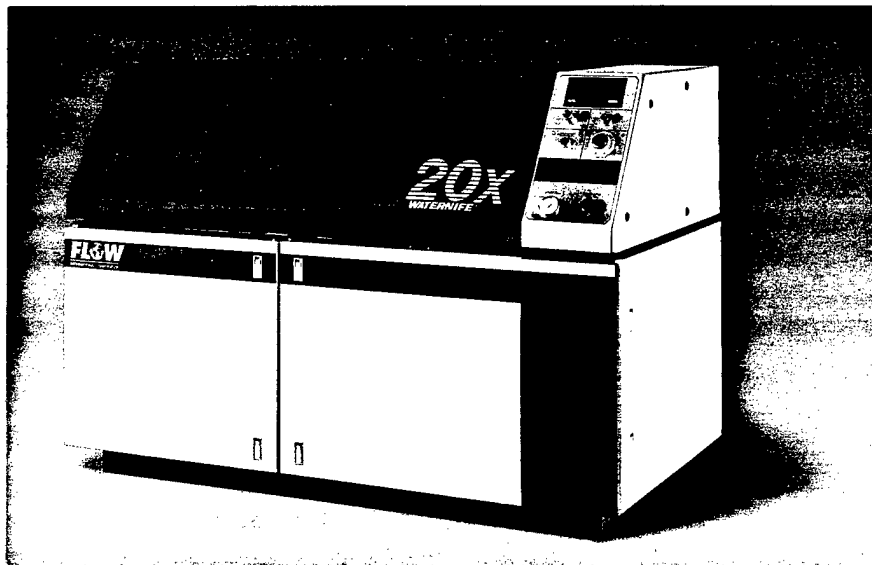

Figure 38. Flow International Model 20X Intensifier Pump

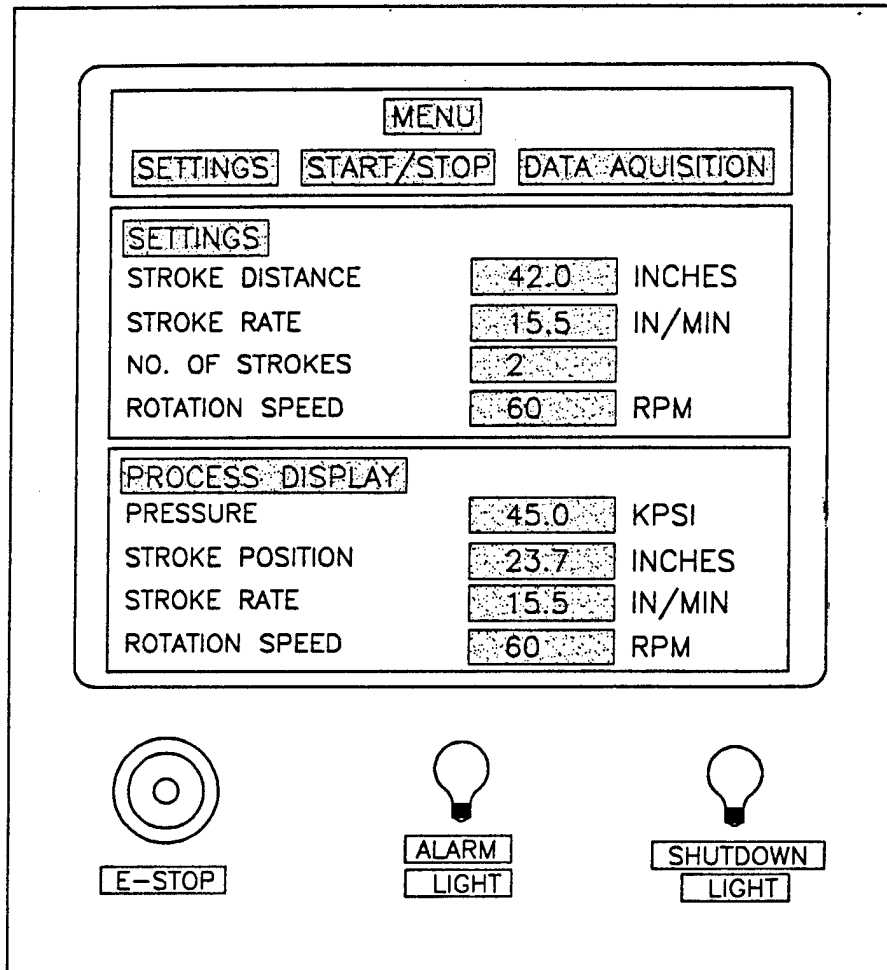

Figure 39. Control Panel Display

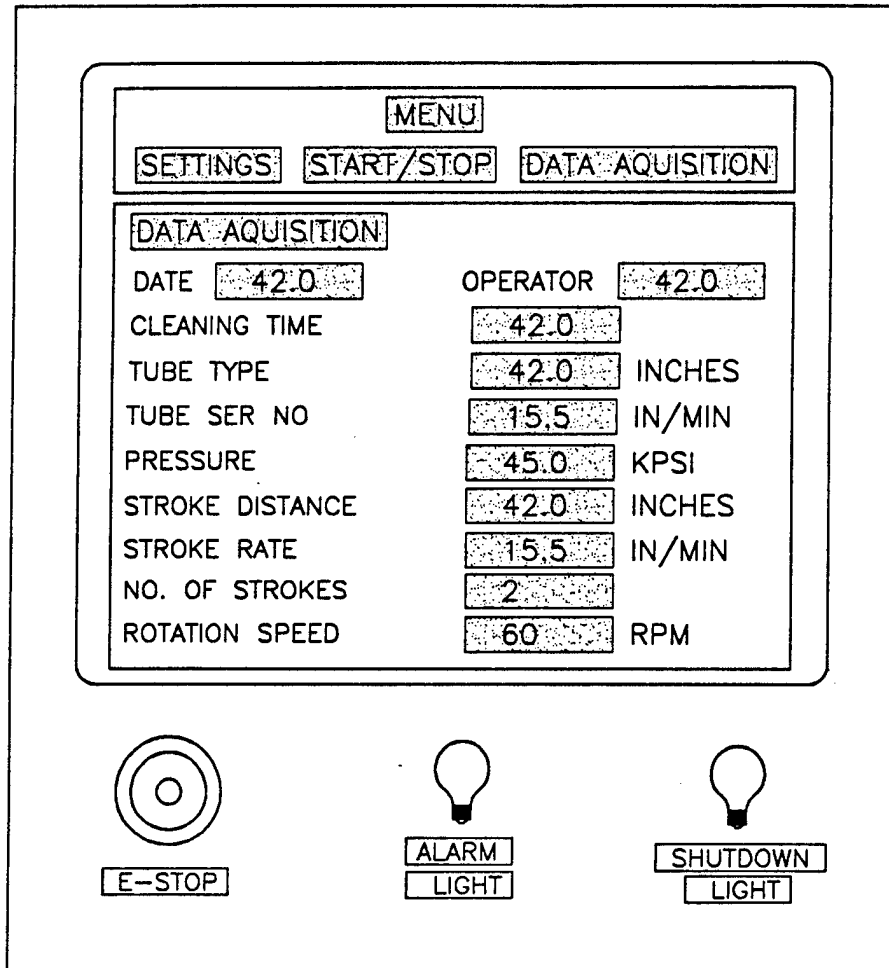

Figure 40. Data Acquisition Display

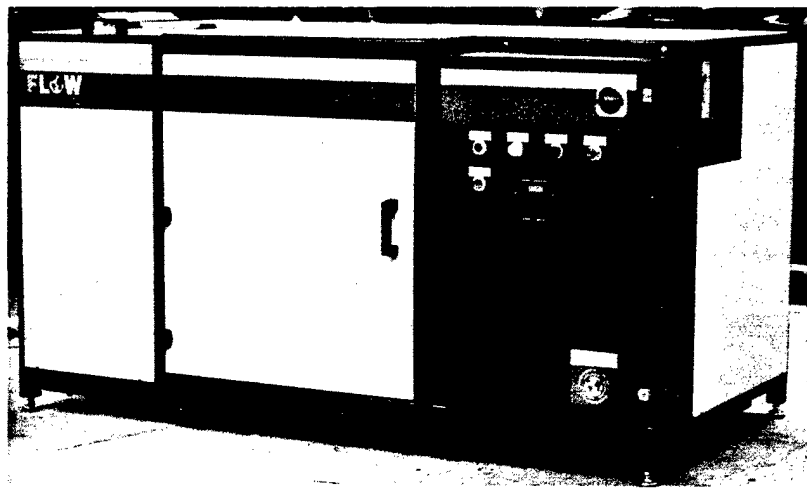

Figure 41. Flow International Water Recycling System

Tube Access

Tube access is assumed to be from both ends. Access may be limited to one end only due to the presence of a 90-degree elbow at the other end of the tube. Access from both ends may be desirable to pull as well as push the lance or wand through the tube.

Coke Deposit Removal

The thickness of the coke deposits is understood to be from a thin surface coating up to complete blockage. A lance or wand that can scour a fully blocked tube would be useful. The most promising design from testing thus far is a forward-firing fan jet since it is capable of cleaning both radially and frontally at the same time. A single-nozzle design would be the most compact and would probably require rotation. On the other hand, a multiple-nozzle design may not require rotation, which eliminates the need for an actuator.

Recommended Waterjet System Features

The preliminary concept design considers system features that are recommended. These are in the areas of operator interface, safety provisions, system packaging, and portability.

Operator Interface	Manually mounts tubes in fixture Sets nozzle stroke distance (inches) Sets stroke rate (inches per minute) Rotation rate (rpm) Sets cleaning pressure Turns on cleaning cycle start switch Turns off cleaning cycle start switch if premature stop is needed
Safety Provisions	Hands off during UHP operation Emergency stop button UHP pump water inlet pressure too low UHP pump oil pressure too high Sump level too high
System Packaging	UHP pump in self-contained package or use facility UHP pump Cleaning machine in self-contained package including water collection sump
Portability	System consists of two modules Cleaning module - 4 feet high by 4 feet tall by 8 feet long Pump - 4 feet high by 4 feet tall by 8 feet long

Recommended Laser Inspection System Features

Operator Interface	Window-based software Simple set- and calibration Sets inspection resolution protected Automatic data archival Graphic and tubular display of results
Safety Provisions	Class I laser product Surge protected Ground fault interrupt
System Packaging	Self-contained enclosure / dust and water resistant Semi-portable Laser sensor retracts when not in use

Cost of UHP Waterjet Cleaning: Economic Analysis

This section discusses the economic analysis in using waterjets for fuel tube cleaning. In the overall waterjet cleaning system, there are two major subsystems; the waterjet cleaning system and the UHP water pump system. The current cost for a 20XD-55 UHP pump system is \$105,387. This consists of two double-acting intensifiers capable of delivering 2 gpm of water at 55 kpsi, 100-hp hydraulic motor, pump motor starter kit, and associated UHP plumbing hardware. It is assumed that the waterjet cleaning system will cost approximately \$100,000. Assuming a 5-year amortization period at 11% interest, with a yearly operational usage of 2000 hours, the hourly capitol payback for this cleaning station will be \$26.80. The costs involved in operating the waterjet fuel tube cleaning system consist of the following:

- Nozzle wear costs
- Fuel tube waterjet cleaning system maintenance costs
- UHP pump maintenance costs
- Water usage costs
- Electrical costs

This analysis assumes the labor costs for an operator using this system are \$60 per hour. The electrical and water costs can vary greatly from location to location, so these costs were based on the utility costs located in the Kent, Washington, area. The UHP pump maintenance costs of \$11.25/hr were obtained from Flow International for running a 20XD-55 UHP water pump system. This includes replacement parts, consumables, and typical labor costs for maintaining this pump.

The cleaning nozzle wear costs assumes that a nozzle will cost \$1,000 to build and that it will need to be replaced after 2,000 hours of operation. Thus the nozzle wear costs will be approximately \$0.50 per hour. This analysis also assumes that the fuel tube waterjet cleaning system's maintenance costs will be \$5.00 per hour. This would include fuel tube fixture maintenance, waterjet hose maintenance, control system maintenance, and the overall cleaning maintenance of the system's housing. Figure 42 shows how these costs relate to one another when including the capitol costs, and Figure 43 shows how the operational costs relate to one another. The actual costs are shown in Table 3.

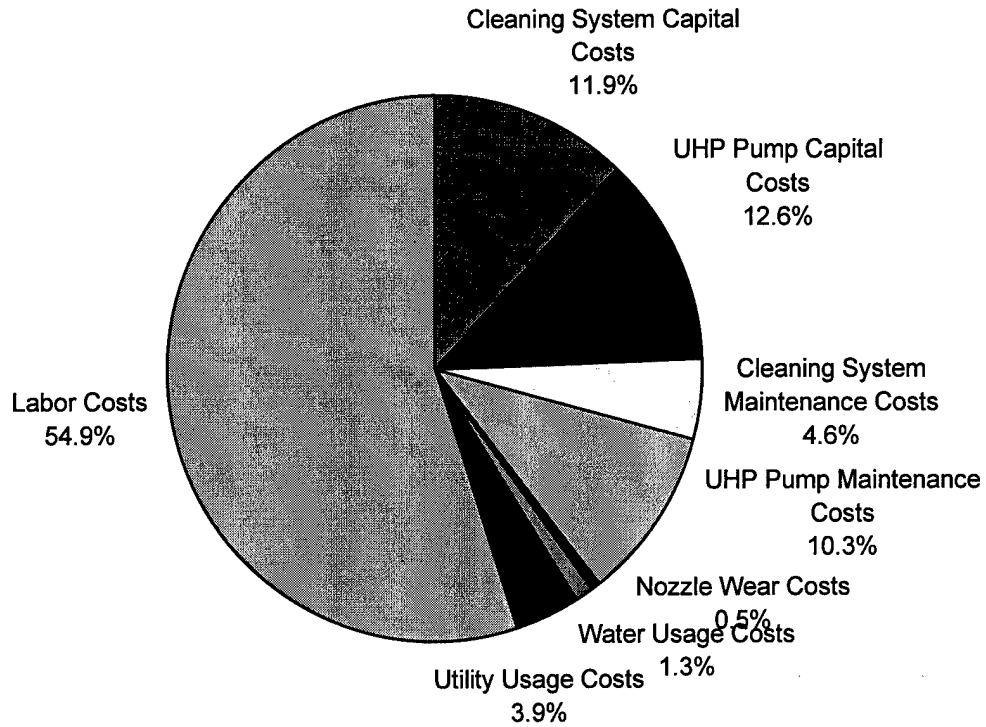

Figure 42. Overall Waterjet Fuel Tube Cleaning Operational and Capital Cost Relationships

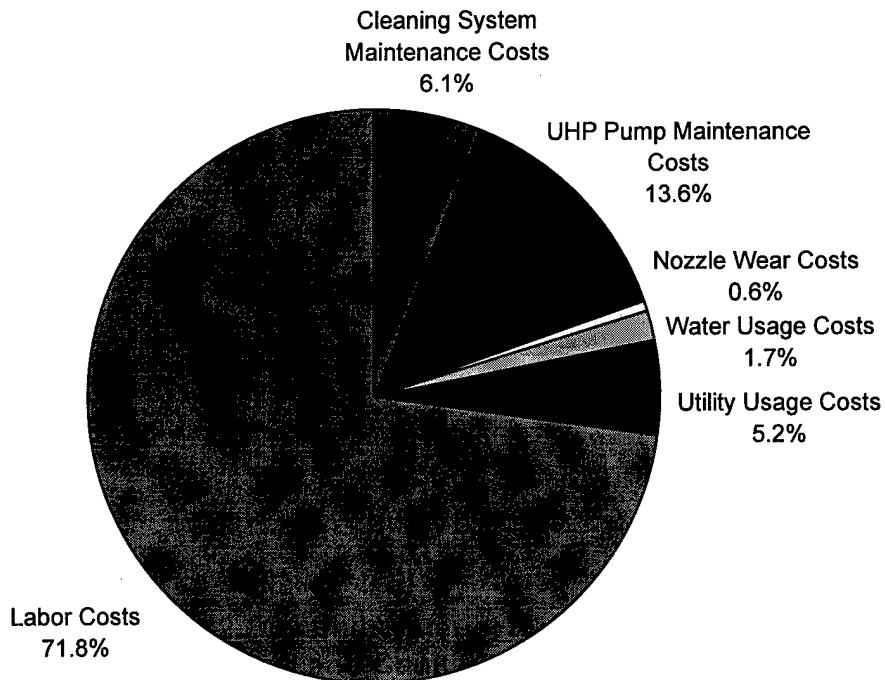

Figure 43. Waterjet Fuel Tube Cleaning Cost Relationships

Table 3. Operational and Capital Waterjet Fuel Tube Cleaning Costs

Cost Area	Operational Costs	Capital Costs
Cleaning System Capital Costs		\$13.05
UHP Pump Capital Costs		\$13.75
Cleaning System Maintenance Costs	\$5.00	
UHP Pump Maintenance Costs	\$11.25	
Nozzle Wear Costs	\$0.50	
Water Usage Costs	\$1.38	
Utility Usage Costs	\$4.30	
Labor Costs	\$60.00	
Total Costs	\$82.43	\$26.80

The following analysis shows the cost effectiveness of cleaning these fuel tubes as opposed to scrapping any coke encrusted fuel tubes. This analysis is based on cleaning the two fuel tubes shown in Table 4.

Table 4. Fuel Tubes

Part Number	NSN	Tube Cost
4045658	4710-01-024-5374	\$266.15
4045660	4710-01-026-0348	\$416.35

Currently, a total of 100 fuel tubes are being checked each month (50 of each tube listed above). Assuming the effective fuel tube length is 50 inches, and the waterjet cleaning rate is 0.50 inches per minute, and the tube cleaning setup time is 1/2 hour, then the waterjet cleaning cost for each of these tubes will be \$167.38. Thus, the cost savings for the above two tubes will be \$344.74 (\$98.77 for P/N 4045658 and \$245.97 for P/N 4045660). The cost savings is the difference between purchasing a new fuel tube and the cleaning costs. If the current scrap rate is 33 percent, then the total waterjet fuel tube cleaning system of \$205,387 will be paid off in 36 months, after which an annual savings of \$68,258.95 can be achieved by cleaning the fuel tubes as opposed to scrapping them.

Laser Inspection

As a result of extensively evaluating the tubing surface in both the fully coked and cleaned configurations by using both laser triangulation sensors and remote video equipment, it can be concluded that a system can be configured to reliably confirm the cleaning process of the tubing. Two types of images can be generated. The first image will be a conventional laser triangulation image of the inside of the tube. This will provide full three-dimensional information and can be used for the initial baseline inspection. The inside surface of the tubing will be mapped, and the operators will be able to measure the coke thickness as a function of position in the tube by comparing the measured tube radius versus the nominal tube radius at any given angular position. A three-dimensional, color, contour map can be easily generated, which will allow the operators to locate potential thick coke deposits.

After the tubes have been cleaned, both the dimensional information and the total reflected light will be used to generate a "laser video" image of the tube surface. An example of such an image is shown in Figure 44. In this case, the clean tube is treated with a coke-like deposit along one axis. As shown in Figure 45, the coke-like material settled along the bottom of the tube and ran along its axis. This simulates an improperly cleaned tube. The full tube scan is shown in the lower left-hand corner of Figure 44, and the zoomed image is shown in the upper right hand portion of the tube. Although the image is somewhat distorted as a function of scaling parameters, it is clearly evident where the scale is relative to the adjacent cleaning tube surface. By working with the color mapping software, we will be able to easily set thresholds that identify acceptable and nonacceptable criteria for coke deposit.

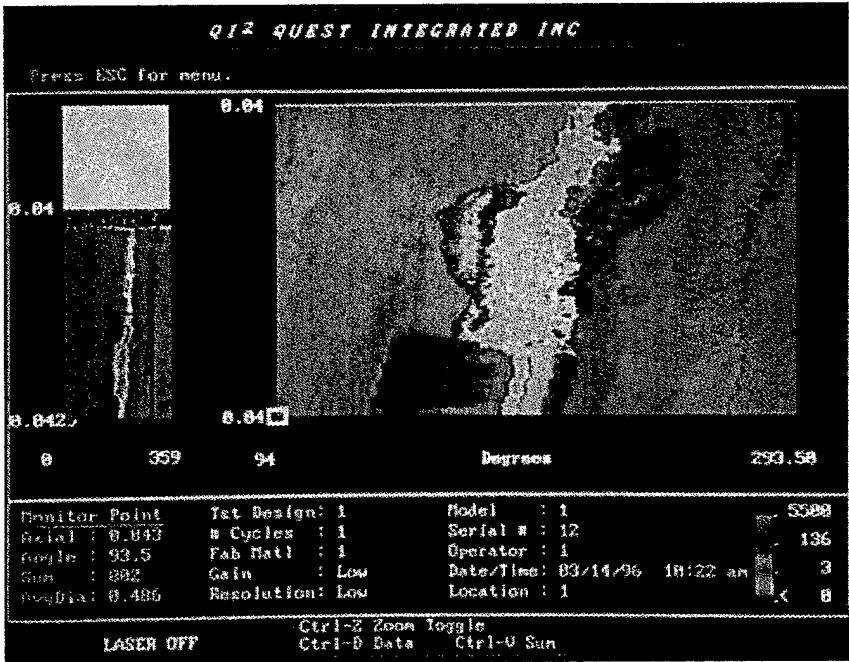

Figure 44. Laser Video Image of the Tube Surface

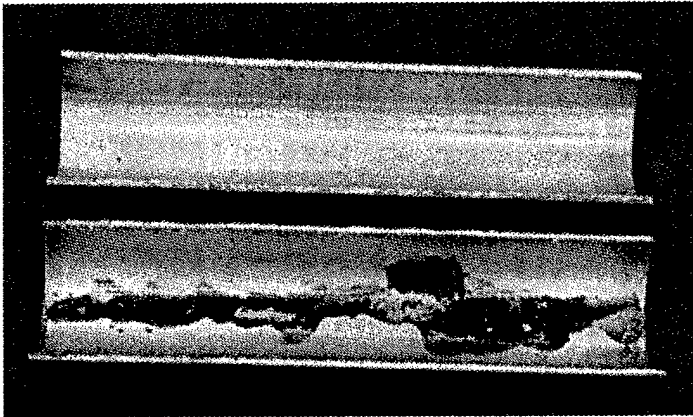

Figure 45. Photograph of Tube with Coke Deposit

In order to illustrate the capabilities of laser-video imaging, a business card was placed in a tube and scanned with a laser-based triangulation probe. The total received light was then plotted two dimensionally and color scaled. As shown in Figure 46, the resulting image is impressive. The features of the card are easily recognizable, and the image appears as if it had been acquired using a conventional CCD camera. Instead, the image is a plot of the intensity profile using an LEP. The significant advantage of the LEP over the CCD is its ability to be packaged in very small configurations. Thus, it can be employed for the inspection of very small tube in cases where CCDs cannot.

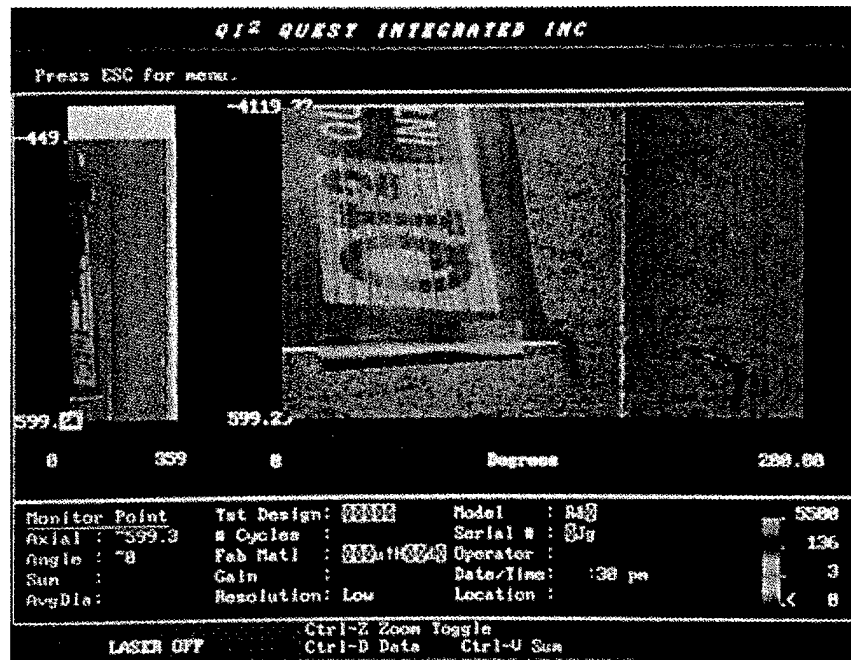

Figure 46. Laser Video Image of a Business Card

By using the combined laser triangulation and laser video imagery, we will not only be able to measure the coke deposit thickness, but we can also measure the remaining tube ID to confirm that no base material has been removed as well as use the laser video image to locate any residual coke deposits that were left uncleaned.

CONCLUSIONS AND RECOMMENDATIONS

Waterjet Cleaning

UHP waterjet coke removal is well-suited to cleaning small-diameter, curved fuel tubes and manifolds. The waterjet process is inherently friendly to the environment, easily automated, and clean. In Phase I of this development, solutions to key hardware and process challenges were developed and demonstrated. Potential Phase III commercialization markets were identified and contacts established. A clear path towards Phase II development and prototyping was mapped.

Fuel tube coke deposits present cleaning difficulties because of their hard physical properties, their varying thicknesses (including complete blockages), and their inaccessibility within long, curved tubes. Under

Under Phase I, the waterjet cleaning process was explored at a variety of pressures, horsepower levels, and jet types and shown to be both effective and controllable. By controlling the process parameters, in combination with appropriate nozzle hardware, waterjets should be useful for the full range of deposit geometries. Also, it has been shown under Phase I that they can be packaged small enough for the tube sizes of interest.

Under Phase I of this program, coke removal was successfully demonstrated using new UHP nozzle hardware designed and built as part of this study. This hardware, including nozzle heads and flexible wand conduits, is characterized by smaller size and greater flexibility than ever built before. In fact, the flexible metal conduit developed for 55-ksi use is 17 percent of the diameter of the smallest standard UHP tubing.

An industrial waterjet cleaning system for fuel tube application is economical as well as feasible. Using Phase I test data and the conceptual design, a conservative payback period has been shown to be 36 months. And these positive economics do not include the additional benefits associated with eliminating the risk of dependency on new tube manufacturers.

In Phase II, an industrial cleaning system will be prototyped, field tested, and delivered to the Air Force for ongoing use. This system will be flexible enough to clean a variety of tube sizes and geometries without expensive custom tooling. The challenges for Phase II are well-defined, with high probabilities for success. These challenges include:

- Carbon deposit characterization, based on actual engine tubes
- Further process hardening, based on the carbon characterization
- Detail nozzle wand design, with lifecycle testing
- Design of a nozzle delivery system
- Design of a cleaning system package, including operator interface and control system
- Establishing system operating procedures for each possible tube type

The hardware and processes developed in Phase II will have application not only for fuel tube cleaning, but in many other industries as well. An example of an alternate application is in heat exchangers, where similar small-diameter tubes must be cleaned. The UHP waterjet tube cleaning system developed in this program is well-positioned for applications not only in jet engines, but in petrochemical, power generation, and the nuclear service industries.

Laser Inspection

The Phase I program clearly confirmed that by using laser triangulation and laser video imagery, the location, measurement, and mapping of coke deposits can be achieved through innovative probe and system design. Providing the Phase II program is directed toward the inspection of 0.562-inch nominal OD tubing, a fully rotating probe could be developed that is capable of negotiating both the straight and bent sections of the tubing. A conceptual illustration of a such a probe is shown in Figure 47. The device will be composed of an articulated sensor assembly, which will either employ a custom motor/encoder and slip ring assembly, which will be housed in an articulated head assembly, or as shown in Figure 48, the articulated sensor will be driven by an external drive system that is capable of operating at distances of up to 10 feet in length. The probe will be a self-contained sensor assembly capable of rapidly negotiating tubing both before and after the cleaning process. The full system, shown in Figure 49, will be comprised of a self-contained delivery system and a data acquisition and control computer. It

would be advisable for the inspection system to be located away from the waterjet cleaning area in order to minimize the potential of exposure to contamination and the ingress of water. The expected laser inspection system specifications are listed below.

Preliminary Functional Specifications

- Axial Scan Range: 90 inches
- Accuracy: ± 0.002 inch
- Scan Type: Continuous helix
- Axial Scan Pitch: 0.05 inch (minimum)
- Diameter Measurement Range: 0.042 to 0.52 inch
- Measurement Spot Size: 0.020 inch
- Scan Rotation Rate: 200 rpm
- Samples Per Revolution: 50
- Cycle Time: Less than 10 minutes per tube
- Weight: 25 lb (approx.)
- Power: 110 VAC/60 Hz, < 300 W

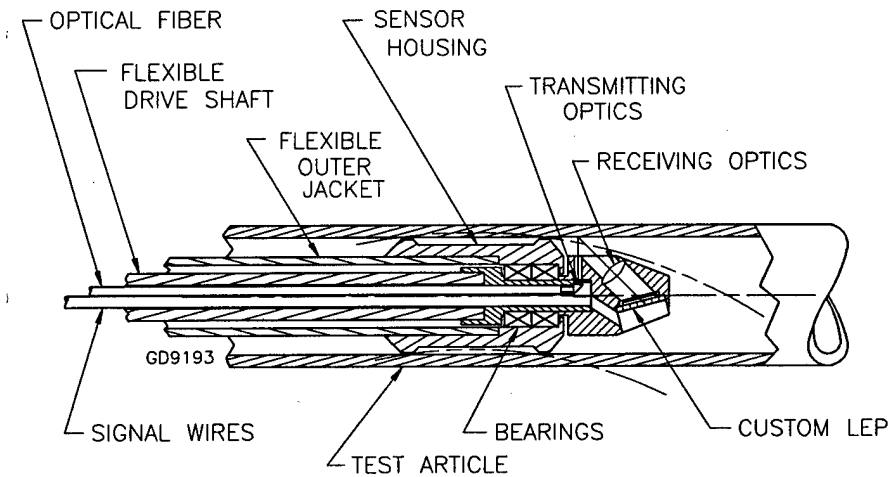

Figure 47. Conceptual Illustration of Probe

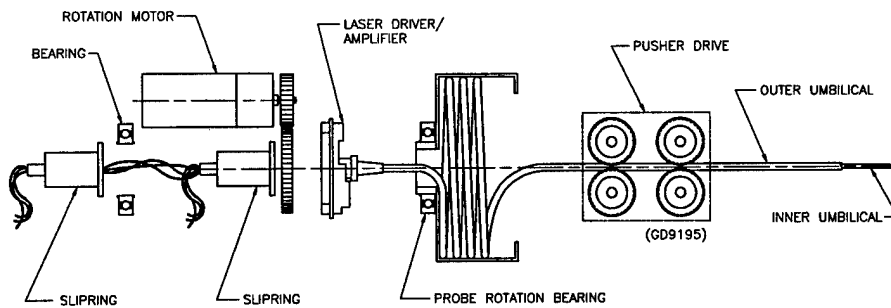

Figure 48. Articulated Sensor Driven by an External Drive System



Figure 49. Full System Illustration

REFERENCES

- Johnson, R. F., Doyle, J. L., and Bondurant, P. D. (1995) "Laser Based Profilometry Using Point Triangulation," in the *Nondestructive Testing Handbook*, Second Edition, Vol. 9, Section 3, Part 4, American Society for Nondestructive Testing, pp. 141-154.
- Sweetman, B. (1993) "G.E. Say No to Coke," *Popular Science*, September, p. 37.
- Technology Transition Office (1991) "Premanganate Rejuvenation System," Air Force Technology Opportunities Program, TechTip No. 91082, 8 November.