

Annual and Final Report on the Project

**Development of Low Loss Multipole RF Filters**

**Grant NO. N00014-96-1-G017**

**DISTRIBUTION STATEMENT A**  
**Approved for Public Release**  
**Distribution Unlimited**

September 30, 1999

Q. Y. Ma

Department of Electrical Engineering, Columbia University,

New York, NY 10027

Tel: 212-854-5080, Fax: 212-932-9421

**Brief Summary**

This is a three-year project, started in July 1997 and ended in July 1999. During contract period, we have completed the technical objectives of this project. The highlights include

- (1) Made, for the first time, 3-pole HTS filters in MHz range on 2-inch wafers.
- (2) Achieved an insertion loss of -0.7 dB and a return loss of -15 dB.
- (3) Invented an active switchable tuning method for turnable HTS filter.

Overall, 2 papers have been published, 3 submitted, 5 conference papers presented and 3 patent applications submitted.

In the first year, an interdigital three-pole bandpass filter was designed and fabricated on a two-inch high temperature superconducting (HTS) film. This interdigital filter, transformed from a standard three-pole Chebyshev low-pass filter, consists of 10 interdigital lumped elements: one capacitor and one inductor in each of three resonators and four matching capacitors. The test results demonstrated a three-pole bandpass filter and showed that the interdigital design had a high insertion loss.

In the second year, the research work was carried out in two directions: improved the old filter structure and developed a new spiral structure filter. The improvements, made to the interdigital capacitor design and fabrication, included adding HTS ground plane, modifying the

DTIC QUALITY INSPECTED 4

19991008 009

values of matching capacitors, and optimizing processing recipe. The results showed some improvement on the device performance. However, with this design the characteristics of the filter were too sensitive to matching capacitors that were very small in capacitance. This problem could not be avoided by choosing larger matching capacitors because of limited size of the wafer. To solve this problem, a spiral-structure was used in an HTS three-pole bandpass filter of 24 MHz design. The filter consists of three self-resonant spirals and two coupling loops: one input and one output, for measurement of the filters. Three different configurations of input/output coupling loops were used in order to optimize the filter performance: big-loop, small-loop-near, and small-loop-far. The best result of these three configurations of coupling was obtained from small-loop-far coupling which gives the three-pole center frequency of 24 MHz, an insertion loss of -2 dB, a return loss of -5 dB, and a stopband of < -40 dB. The progress of the project was made with using the spiral-structured filter design in decreasing insertion loss, increasing return loss and increasing stability and repeatability in fabrication.

In the third year, the research work was carried out in improvement of the spiral-structured filter and in design of a frequency switchable filter. First, some modifications were made to the spiral-structured filter design and fabrications. We made much progress of the project with the new spiral filter design in decreasing insertion loss, increasing return loss and increasing stability and repeatability in fabrication. The best result obtained gave the three-pole center frequency of 18 MHz, with an insertion of -0.7 dB, and a return of -15 dB. Second, for the switchable filter, we explored a frequency switch circuit of the HTS RF device using active electronic control (current or voltage), in which a resonator was magnetically coupled with an HTS switch circuit, a resonator by itself. When the control current (or voltage) applied to the switch circuit was zero (off), the two resonators were in superconducting state and coupled with each other, and formed a resonator with frequency  $f_1$ . By converting one resonator into non-superconducting state using controlling current (or voltage), we were able to change the resonant frequency into the resonant frequency of the resonator remained in superconductive state,  $f_2$ . A frequency shift of a switchable resonator from 95.7 MHz to 101 MHz was obtained with a control voltage.

## The first year

### 1. Design

The bandpass filter was transformed from a standard 3-pole Chebyshev low-pass filter with specification shown as below.

Central Frequency $f_0$	15 MHz
Band width (BW)	15 kHz (0.1% $f_0$ )
Insertion Loss (S12)	< 0.3 dB
Return Loss (S11)	< -20 dB
Stop Band at 4 times BW	< -40 dB

The circuit and simulation results are shown in Fig. 1 and Fig. 2. All simulations were done with HP EESof, a simulation suite of microwave communication circuit.

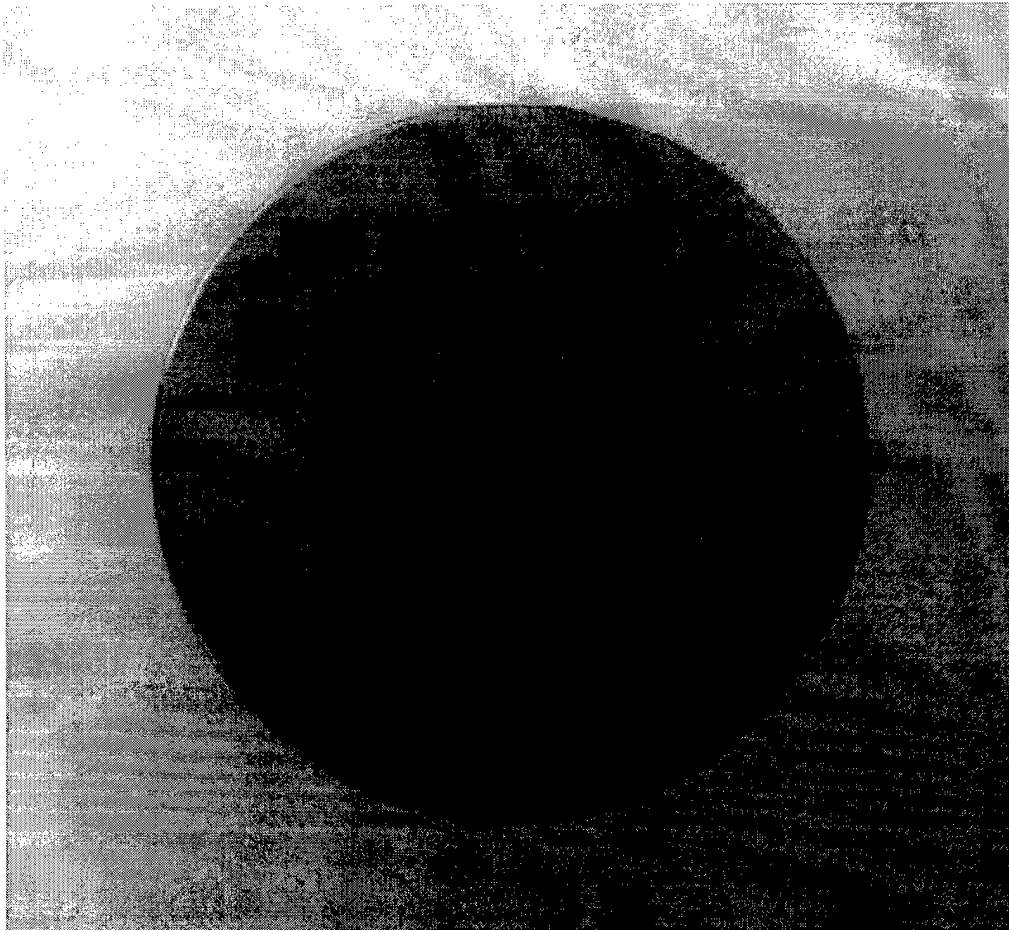

Fig. 1. Photograph of a three-pole filter.

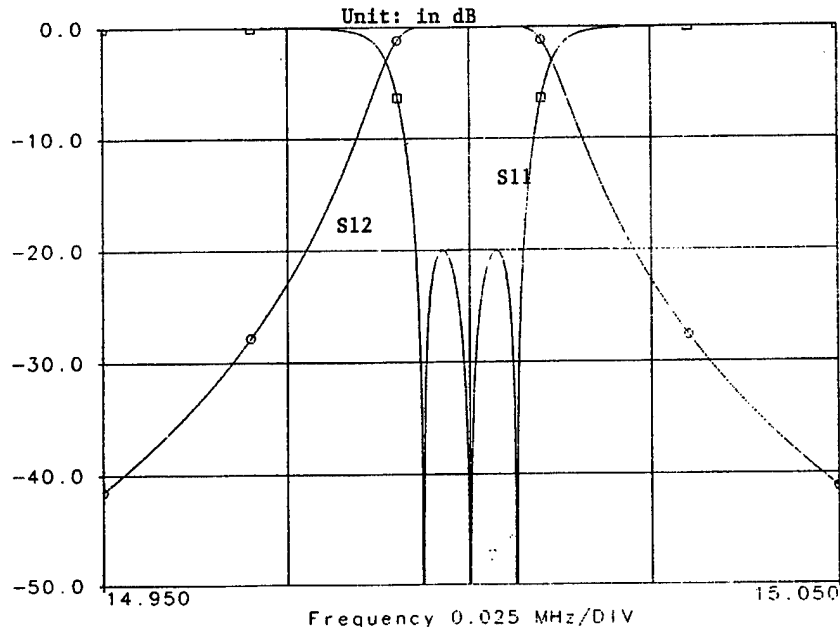

Fig. 2. Circuit simulation result with HP EESof.

To implement such a circuit on HTS thin film, we choose corresponding microstrip line structure. Since the inductor model in EESof library requires a gold bridge to connect the center lead to the outside one, which causes too much additional loss, we use Meander Line Inductor instead to maintain the coplanar structure. This increases the total area slightly but minimized the loss due to wire banding. Obviously, the final layout fits well in a two-inch wafer.

## 2. Fabrication and Testing

Two filters and several individual capacitors and inductors were fabricated on three two-inch wafers (200 nm YBCO on 20 mil LAO substrate). After that, 50-nm silver and 150-nm gold was deposit as contact pads.

Two filters, labeled as filter1 and filter2, were tested in Naval Research Laboratory at a standard microwave test bed. The temperature in the system could be adjusted from room temperature down to 10K. An Indium/gold plate was used as grounding plane. All filters were tested at different temperature (13K, 30K and 50 K) and different input power level. The result is shown in Table1. After testing, condensation was found on filter2 during warm-up process, which degraded the superconductor. Figure 3 is S-parameter response of filter1.

Table 1. Test result of filters

Filter	T <sub>c</sub> (K)	f <sub>0</sub> (MHz)	BW(kHz)	I. L. (dB)	Pass Band Ripple (dB)
filter1	60-70	18.25	300	-20	10
filter2	50-60	17.7	60	-15.4	2
design	-	15	15	0.3	0.3

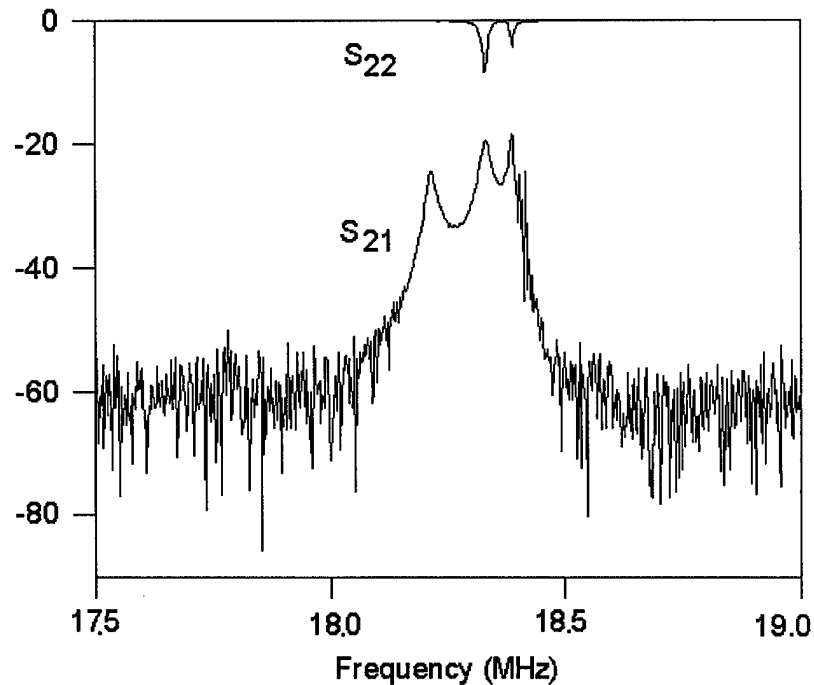

Fig. 3. Response of the filter made in May 1997

It could be seen in Table 1 that the central frequency is off about 20%, and the bandwidth is much larger than our design. Insertion loss and pass band ripple is higher than expected. Besides, the sample is power sensitive. The response is completely suppressed at normal power levels (0 dBm or 1mw) though this is a common phenomenon for HTS microwave devices. The power was set to -20 dBm for all measurements.

Several interdigital capacitors and meander line inductors were also tested in order to get more precise model and improve our design.

### 3. Analysis

The test result was not so satisfactory as desired. But for the first try, this result gives us as much information for further modification.

#### 1. Central Frequency

The capacitor and inductor in each resonator determined the central frequency. The test result of interdigital capacitor shows that the capacitance derivation is within 2% as designed, which is fairly good. But the result is not the same for meander line structures. It was necessary to test more inductors and to improve the model.

## 2. Band Width, Insertion Loss, and Pass Band Ripple

The bandwidth, insertion loss, and pass band ripple are related to resonator structure used in the filter, especially, to the coupling capacitors between each resonator.

The coupling capacitor is several orders smaller than the resonance capacitor (about 0.2 pF compared to 200 pF). Taking account of the parasitic capacitance of the interconnect microstrip line and inaccuracy due to fabrication, the derivation could be the same order as the capacitor itself. These led to a wide pass band, a large insertion loss, and pass band ripple. After changing the coupling capacitors by an offset with the same order, we got the simulation result similar to our experiment.

## The second year

### 1. HTS Wafers and Filter Fabrications

Two batches of double-sided YBCO wafers were purchased from Prof. Kinder's group in Germany. All films were deposited by co-evaporation on 20 mil LaAlO substrates. The films have very smooth surface and a  $T_c$  above 85 K and  $J_c$  above  $2 \times 10^6$  A/cm<sup>2</sup> at 77K.

A total of 16 filters were fabricated using either the interdigital capacitor or spiral design in the Electrical Engineering Department at Columbia. Dr. Jeff Pond at NRL tested two of these filters at cryogenic temperature. The rest devices were tested at Columbia at 77 K or below.

### 2. Continuing Work on the Interdigital Filter Design

#### a. Design

As stated in the first year report, we have continued the work on the 3-pole Chebyshev filter design with specifications shown as below.

Central Frequency $f_0$	2 - 30 MHz
Band width (BW)	0.1% $f_0$
Quality factor	1000
Insertion Loss ( $S_{12}$ )	< -0.3 dB
Return Loss ( $S_{11}$ )	< -20 dB
Stop Band at 4 times BW	< -40 dB

**b. Fabrication and Testing**

To improve the interdigital design, first we verified the individual elements, capacitor and inductor. Two testing structures were made and sent to NRL for testing in November 1997. The result, as shown in Fig. 4, agrees with our simulation. The phases of the inductor and capacitor are 90 degree and -90 degree at 15 MHz, respectively, which indicated that our model used in individual element design is satisfactory.

Two more devices were made and tested at Columbia afterwards and the results (Fig. 5) are summarized as below:

Device	BW	I.L.	R.L.	Temp.	Power	comments
1	8 MHz	-2 dB	-12 dB	26 k	-10 dBm	BW wide
2	8.4 MHz	-2 dB	-10 dB	26 k	-10 dBm	BW wide

Table2. Summary of continuing work on old design

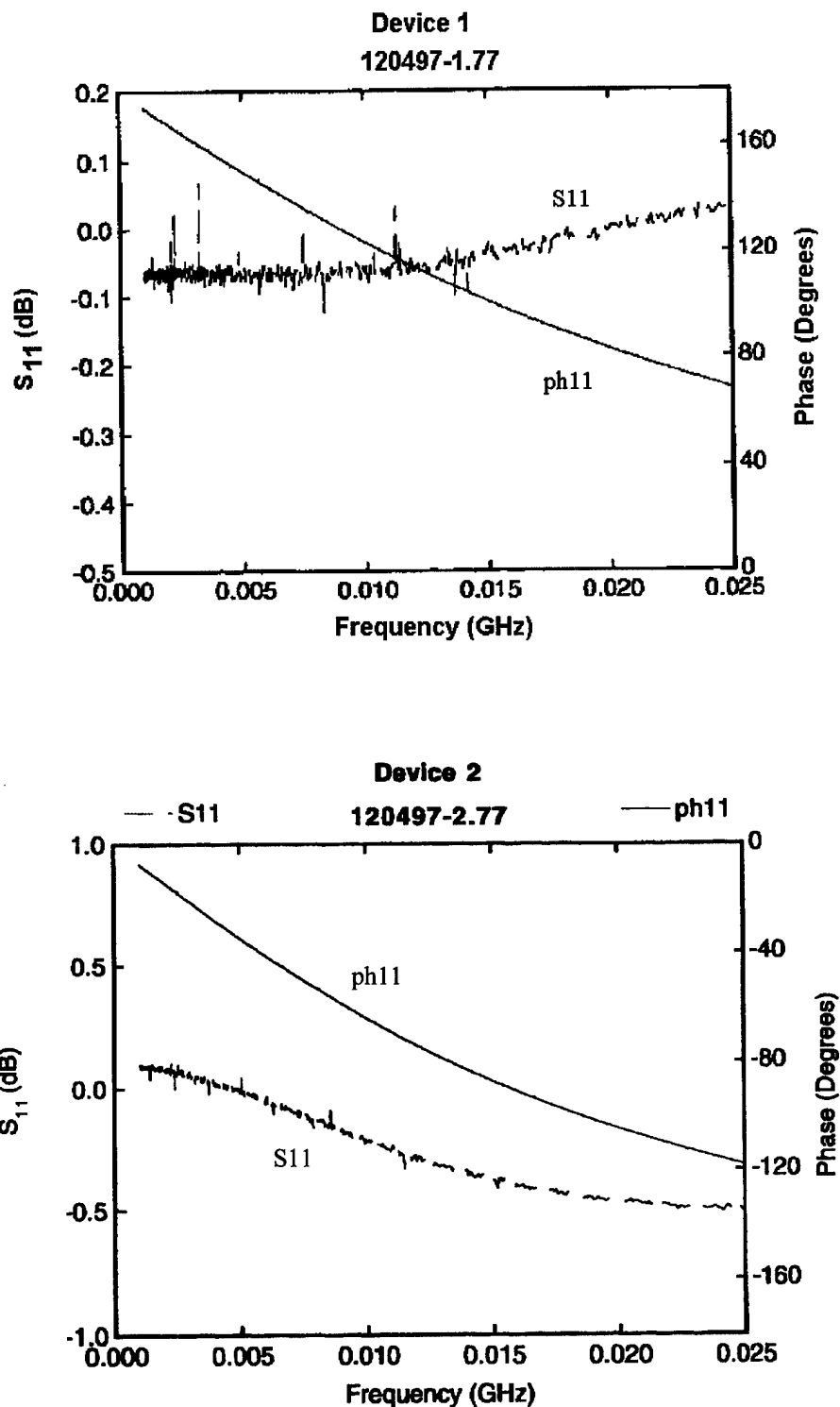

Fig.4 Testing results of an inductor (Device 1) and a capacitor (Device 2) made with YBCO film

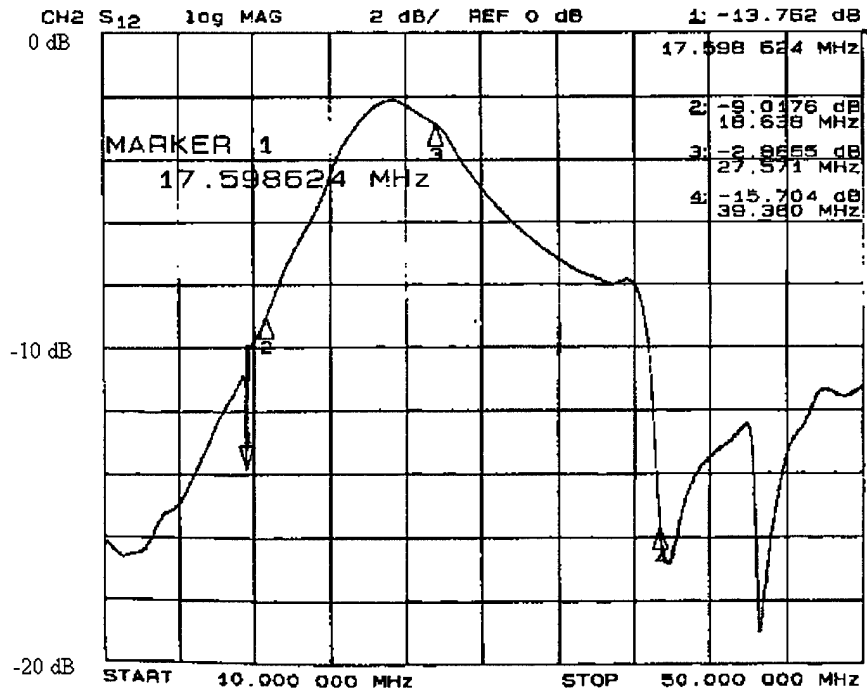
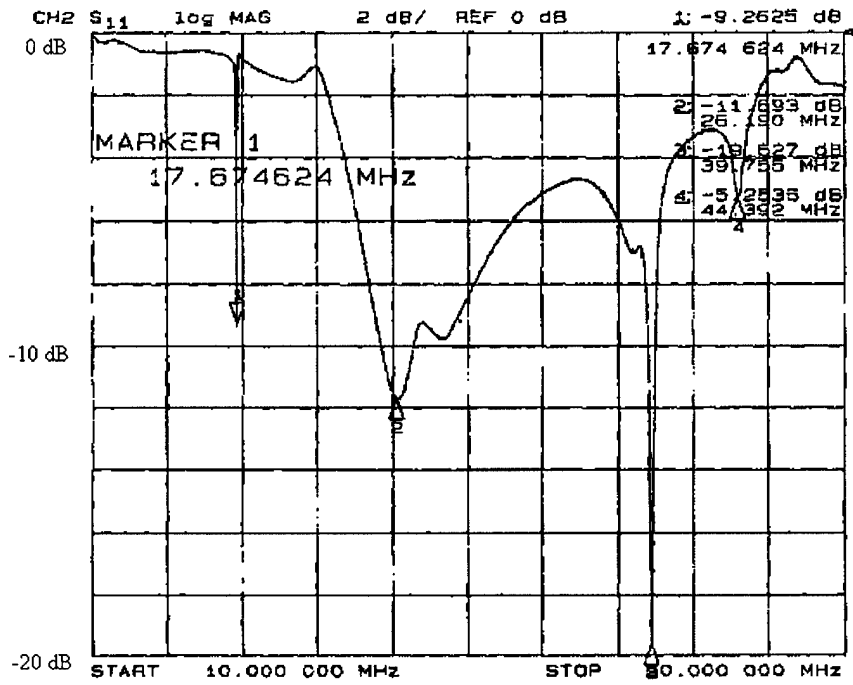

Fig. 5. Response of filter made in May 1998 shows lower insertion loss and high return loss, but with a widened bandwidth

### **c Analysis**

Compared with the results obtained in the first year, the insertion loss and return loss were improved from -20 dB to -2 dB for insertion loss and from -1 dB to -10 dB for return loss. But the bandwidth of the filter response was widened. The tested results of individual elements were in good accordance with our simulation. We believe that the deference in the performance of the filter from the design is due to the mismatching between resonators and the mismatching between the filter and the testing equipment. The frequency of this design can not be changed easily for the following reasons. To achieve narrow bandwidth and low insertion loss, our design were made from large capacitors (~200 pF) for resonant and very small capacitors (~0.2 pF) for matching. The characteristics of the filter are very sensitive to the values of matching capacitors. Therefore, the distributed parasitic capacitance or inductance and the variation of the values of the elements from fabrication are big enough to change the characteristics of the filter significantly. Based on the analysis we shifted our focus to the new structure in the later stage of the project discussed below.

## **3 Spiral Design of Three-pole Filter**

### **a Multiple-spiral Resonator**

The key of our new 3-pole filter design was a multiple-spiral resonator, which consists of three identical spirals. A 3-spiral resonator is shown in Fig. 6. These three spirals were patterned and fabricated on a two-inch HTS wafer. Each spiral contained 20 turns with homogenous separation between adjacent turns. These three spirals were arranged in parallel to each other and mutually coupled.

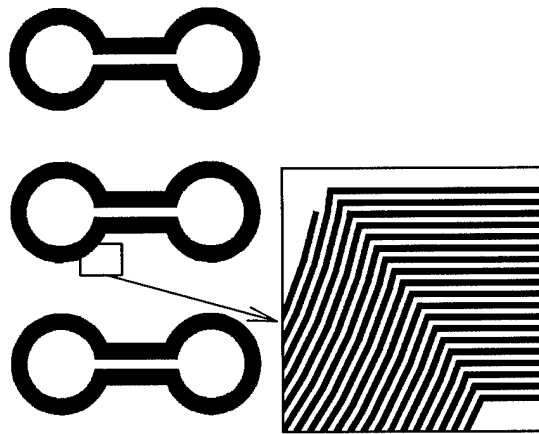

Fig. 6 A 3-spiral resonator

### **b Three-pole Filter**

A 3-pole filter was made based on a 3-spiral resonator with two copper input and output coupling loops, as shown in Fig. 7. Several different layouts of the 3 spiral structures were designed and fabricated.

### **c Input and Output Coupling Loops (copper wire)**

Three different kinds of coupling are used: (i) big-loop, (ii) small-loop-near, and (iii) small-loop-far, as shown in Fig. 7. The coupling loops were made of fine copper wires and connected to coaxial cables.

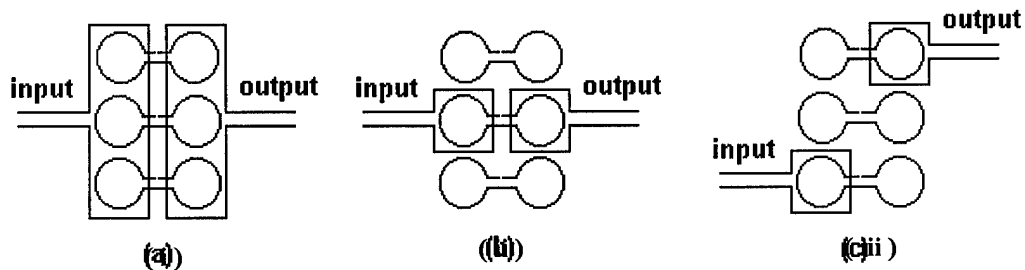

Fig. 7 Three coupling methods with two copper loops: (i) big-loop, (ii) small-loop-near, and (iii) small-loop-far

**d Results**

Three 3-pole-filters were tested in liquid Nitrogen at 77K with three different coupling loops, as shown in Fig. 7 (i), (ii), and (iii). Return loss ( $S_{11}$ ) and insertion loss ( $S_{12}$ ) were measured with a HP-8712B RF Network Analyzer. Three peaks were found in  $S_{11}$  and  $S_{12}$  for all three filters. The three peaks measured with small-loop-far (iii) were less separated.

(i) Big-loop (#S1, Fig. 8)

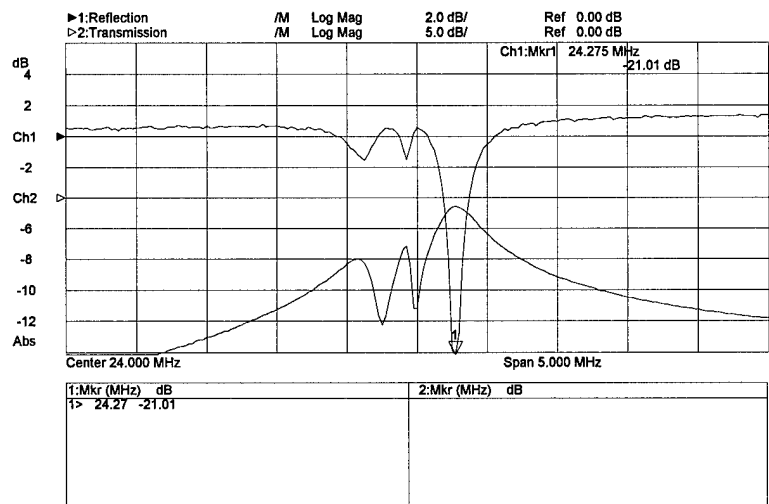

Fig.8 Return loss ( $S_{11}$ ) and insertion loss ( $S_{12}$ ) measured with big-loop (#S1)

(ii) Small-loop-near (#S2, Fig. 9)

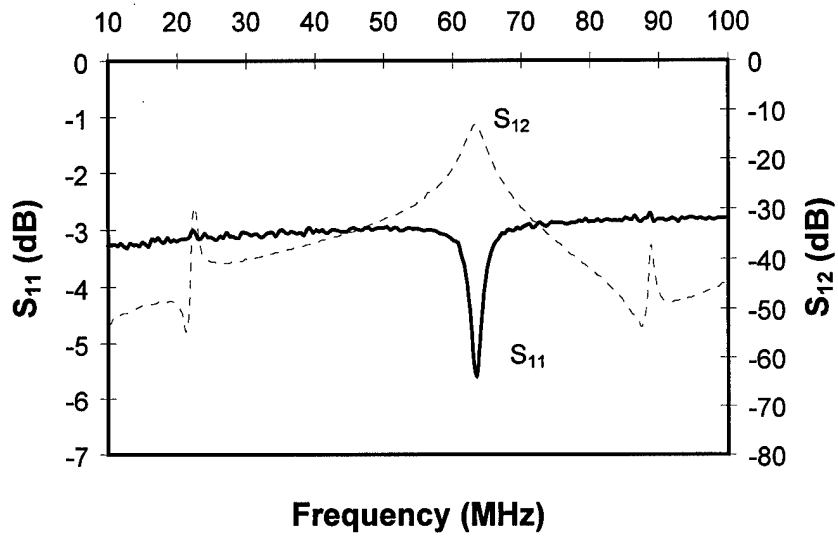

Fig. 9 Return loss ( $S_{11}$ ) and insertion loss ( $S_{12}$ ) measured with small-loop-near (#S2)

(iii) Small-loop-far (#S3, Fig. 10)

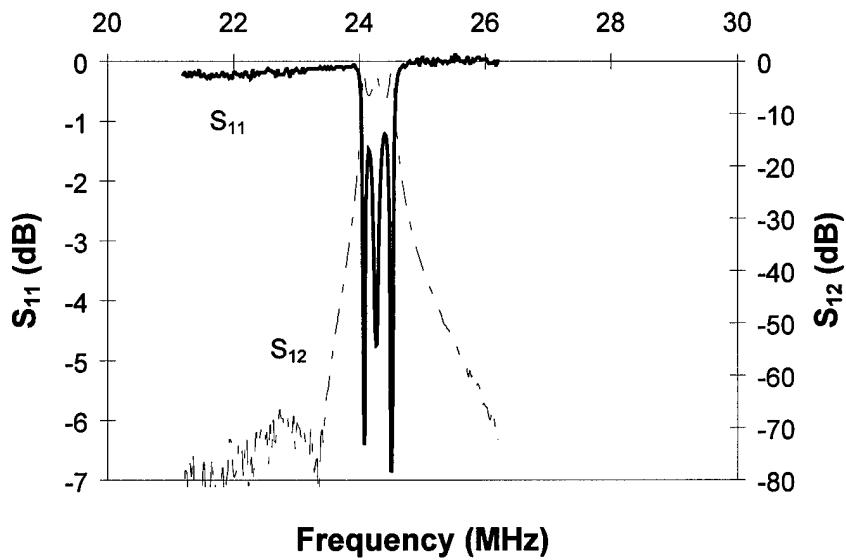

Fig. 10 Return loss ( $S_{11}$ ) and insertion loss ( $S_{12}$ ) measured with small-loop-far (#S3)

		Peak #1		Peak #2		Peak #3	
		S <sub>11</sub>	S <sub>12</sub>	S <sub>11</sub>	S <sub>12</sub>	S <sub>11</sub>	S <sub>12</sub>
#S1	f (MHz)	23.65		23.9		24.27	
	loss (dB)	-3.5	-8	-3.5	-7	-21.01	-5.5
#S2	f (MHz)	22.55		63.33		88.74	
	loss (dB)	-3.03	-29.56	-5.48	-12.88	-2.7	-37.28
#S3	f (MHz)	24.07		24.28		24.5	
	loss (dB)	-6.37	-2.02	-4.62	-2.56	-6.55	-2.05

Table 3. Summary of three different 3-pole filters based on new designs

The bandwidth was about 0.43MHz. The maximal insertion loss between 24.07 and 24.50 MHz is -6.91 dB. At lower (<23.77 MHz) or higher (>25.03 MHz) frequency the insertion loss were lower than -40 dB. Based on these results a patent application was filed for the new design.

### e Analysis

The new designed 3-pole filters with two small coupling loops (far) had three poles at about 24 MHz and distributed in about 0.5MHz. The insertion loss was about -2dB and return loss is about -5dB. Even though this design was not satisfactory, it was closer to our aims.

### **The third year**

In the third year, the research work has been carried out in two directions: improving the spiral filter and design switchable filter. Some modifications were made to the spiral design and fabrications. The project has made much progress with the new spiral filter design in decreasing insertion loss, increasing return loss and increasing stability and repeatability in fabrication. The best result obtained gave the three-pole center frequency of 18 MHz, with an insertion of -0.7 dB, and a return of -15 dB.

### **1. Elliptic spiral design of three-pole filter**

Based on the design and the results of the second year, in the third year we have made a new design, or an elliptic spiral design, which has smaller bandwidth, lower insertion loss and higher return loss, and higher Q.

In elliptic spiral design of the three-pole filter, there are three separated, however, closely located resonators and two pick-up loops which are placed on the top of two resonators, as shown in Fig. 11 (left). The three resonators, identical in shape and size with each other, are made of HTS thin film, patterned and fabricated on a two-inch wafer with an HTS thin film (300 nm YBCO on LAO substrate with 0.508 mm of thickness), as shown in Fig. 11 (right). The resonator is a self-resonant ellipse-like spiral, of which the shape is a combination of two half circle on the two ends of a rectangular. The spiral contains 25 turns with homogenous separation between adjacent turns, as shown in Fig. 12. The two pick-up loops are made of copper wire with the same shape and size of the HTS resonators.

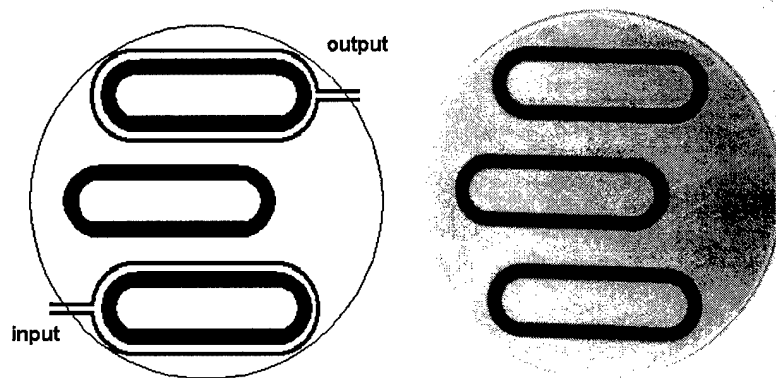

Fig. 11. A three-pole filter made of three HTS resonators and two copper coupling loops (left) and a photo of three HTS resonators on one LAO substrate (right)

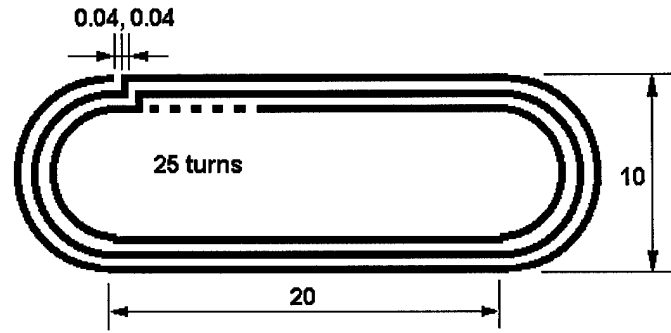

Fig. 12. A 25-turn elliptical spiral resonator at 18 MHz was designed as the basic element used in a three-pole filter. It was fabricated on a wafer with a high-temperature superconducting thin film.

This elliptical spiral design was based on the old design (1998). In the old design any one of three HTS resonators was distorted spiral (two overlapped circles). With the ellipse-like spiral the new design has improved the coupling between two resonators, therefore decreased the insertion loss.

## 2. Modeling for design

The self-resonant elliptical spiral resonator was simulated using an equivalent circuit with lumped elements as shown in Fig. 13. In the circuit,  $V$  represents source,  $R_1=50$  Ohm, the input resistance;  $R_2$  the loss resistance of the spiral,  $C_2$  the effective inter-turn capacitance,  $L_1$  the inductance of the pick up loop, and  $L_2$  the effective inductance of the spiral. The inductance were calculated by

$$L_2 = 0.03937 \frac{a^2 n^2}{8a + 11w} \quad (1)$$

$$L_1 = \frac{1}{n^2} L_2$$

where  $L$  are in nanohenry,  $a$  is an radius of a circular spiral,  $w$  the width of the spiral, and  $n$  the number of turns of a spiral, as shown in Fig 13. The effective radius of our noncircular spiral was calculated by

$$a = \sqrt{\frac{\text{area of a spiral}}{\pi}} \quad (2)$$

The coupling between  $L_1$  and  $L_2$  was described by a mutual inductance,  $M_{12}$ . As an approximation,  $M_{12}$  was calculated by

$$M_{12} = knL_1 \quad (3)$$

where  $nL_1$  is the mutual inductance when  $L_1$  is placed on the top of  $L_2$  and  $k$  is a matching coefficient between  $L_1$  and  $L_2$ . The circuit can be analysed by

$$\begin{aligned} R_1 I_1 + j\omega L_1 I_1 + j\omega M_{12} I_2 &= V \\ j\omega M_{12} I_1 + j\omega L_2 I_2 + \frac{1}{j\omega C_2} I_2 + R_2 I_2 &= 0 \end{aligned} \quad (4)$$

where  $\omega = 2\pi f$  is angular frequency and  $j = \sqrt{-1}$ .

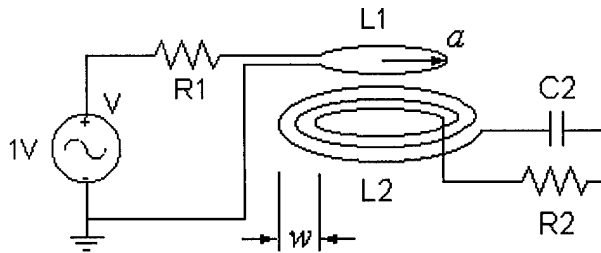

Fig. 13. Model of the self-resonant spiral resonator

Similar to the self-resonant spiral resonator, a three-pole filter was simulated by a circuit model that is shown in Fig. 14.

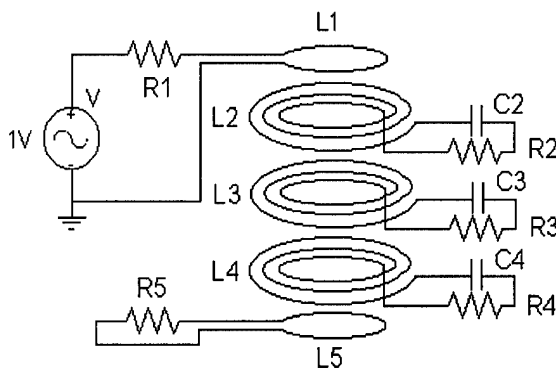

Fig. 14. A model of three-pole spiral filter.

### 3. Results

A single spiral was tested at 77 K as a resonator with a copper coupling loop. The reflection of this spiral resonator is shown in Fig. 15. The resonant frequency is 17.855 MHz and unloaded Q-value is over 13,000. Based on this resonator design, a three-pole filter was designed, fabricated, and tested. The result obtained gave the three-pole center frequency of 18 MHz, with an insertion of -0.7 dB, and a return of -15 dB as shown in Fig. 16[8]. The results of these three filters are summarized in Table 4.

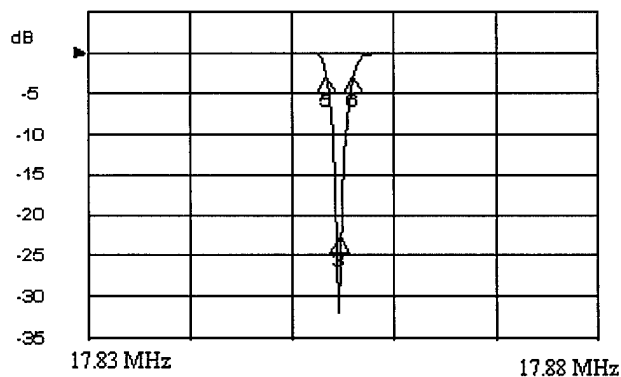

Fig. 15. Measurement of the reflection of a 25-turn spiral resonator at 18 MHz.

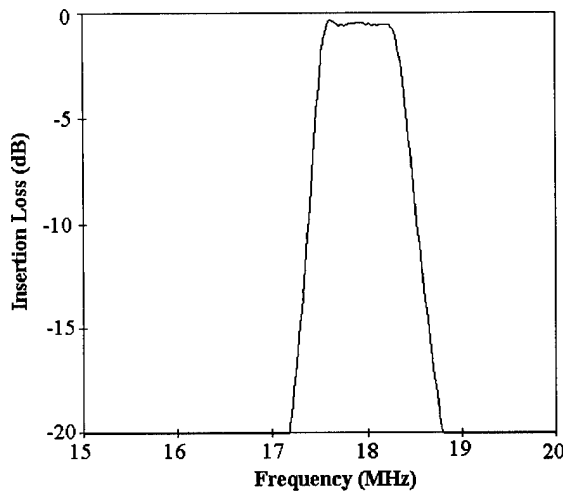

Fig. 16. Return loss ( $S_{11}$ ) and insertion loss ( $S_{12}$ ) of an HTS three-port filter.

TABLE 4. SUMMARY OF THE 3-POLE FILTERS

	Peak #1		Peak #2		Peak #3	
	$S_{11}$	$S_{21}$	$S_{11}$	$S_{21}$	$S_{11}$	$S_{21}$
f(MHz)	17.63		17.93		18.18	
loss(dB)	-18.36	-0.38	-19.34	-0.44	-21.21	-0.56

#### 4. Active frequency-switching concept

To approach active frequency tuning device, the previous proposed design was using a ferroelectric-HTS hybrid structure. However, our experiment showed that the presence of ferroelectric material decreased the Q value of HTS device so the resonant peak disappeared. We modified our approach and explored a frequency switch circuit of the HTS RF device using active electronic control (current or voltage), in which a resonator (Part A in Fig. 17) was magnetically coupled with an HTS switch circuit (Part B in Fig. 17, also a resonator of itself). Part A and Part B were fabricated on two separated films. The electrical control signal was applied through two gold wires bonded to the two ends of the switch circuit (Part B). The wire bonding process is commonly used to make connections in micro processing, described in

Appendix I. When the switch K was off, the two resonators were in superconducting state and coupled with each other, and formed a resonator with frequency  $f_1$ . By converting Part B of the device into non-superconducting state using controlling current or voltage (K was on), we were able to change the resonant frequency into the resonant frequency of Part A,  $f_2$ . A frequency shift of a tunable resonator from 95.7 MHz to 101 MHz with a control voltage was obtained, as shown in Fig. 18. This result is very encouraging since it shows an innovative method of tuning for HTS devices.

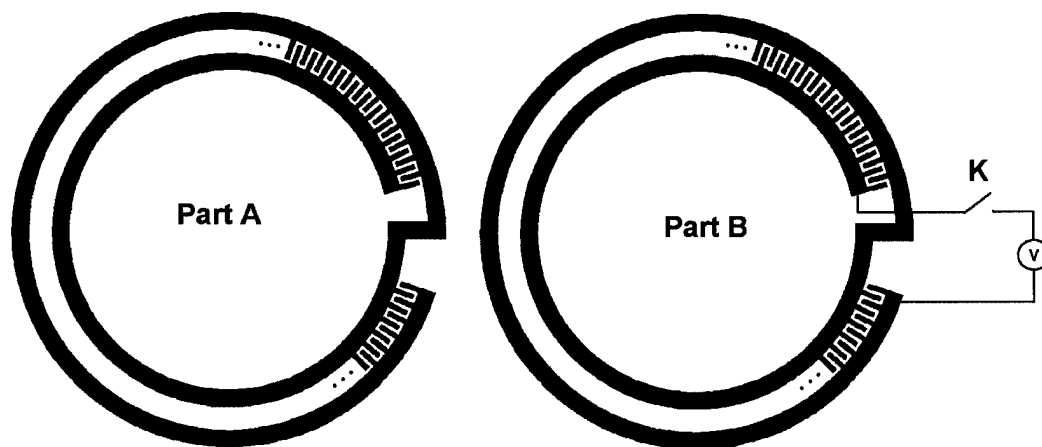

Fig. 17. Layout of an HTS tunable resonator consist of a HTS resonator (Part A) and an HTS switch circuit (Part B). The resonant frequency can be changed with turning on or off the voltage control signal.

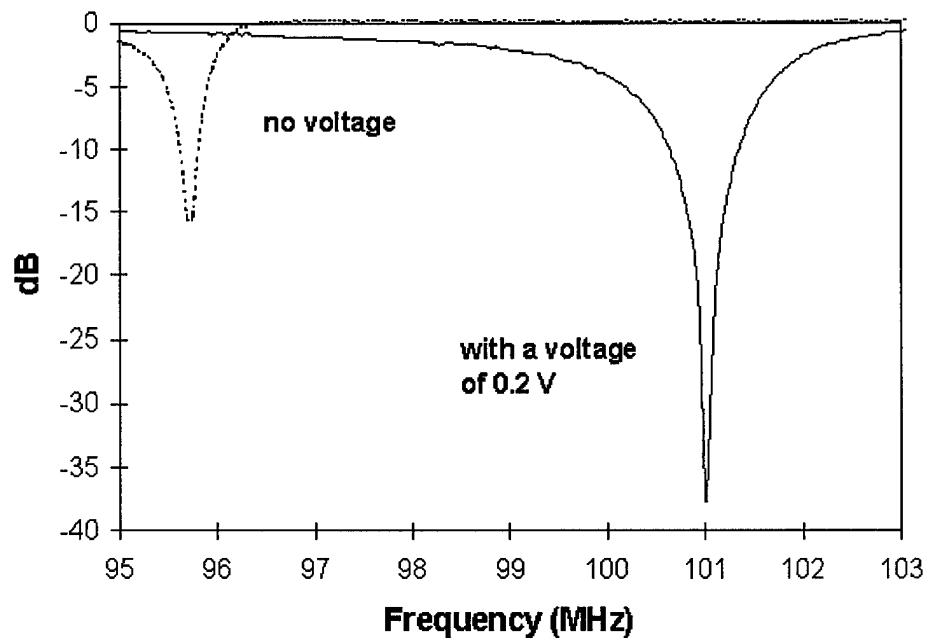

Fig. 18. Response of a tunable resonator with an active voltage control.

The bandwidth is about 0.43MHz. The maximal insertion loss between 24.07 and 24.50 MHz is -6.91 dB. At lower (<23.77 MHz) or higher (>25.03 MHz) frequency the insertion loss are lower than -40 dB. Based on these results a patent application was filed for the new design.

REPORT DOCUMENTATION PAGE			Form Approved OMB No. 0704-0188	
<small>Public reporting burden for this collection of information is estimated to average 1 hour per response, including the time for reviewing instructions, searching existing data sources, gathering and maintaining the data needed, and completing and reviewing the collection of information. Send comments regarding this burden estimate or any other aspect of this collection of information, including suggestions for reducing this burden, to Washington Headquarters Services, Directorate for Information Operations and Reports, 1215 Jefferson Davis Highway, Suite 1204, Arlington, VA 22202-4302, and to the Office of Management and Budget, Paperwork Reduction Project (0704-0188), Washington, DC 20503.</small>				
1. AGENCY USE ONLY (Leave blank)	2. REPORT DATE 08/21/99	3. REPORT TYPE AND DATES COVERED Final Report 07/96-07/99		
4. TITLE AND SUBTITLE Development of low loss multipole RF filters			5. FUNDING NUMBERS N00014-96-1-G017	
6. AUTHOR(S) Q.Y. Ma				
7. PERFORMING ORGANIZATION NAME(S) AND ADDRESS(ES) Columbia University Department of EE, 1312 Mudd New York, NY 10027			8. PERFORMING ORGANIZATION REPORT NUMBER Final (97-99) including (Annul 99)	
9. SPONSORING/MONITORING AGENCY NAME(S) AND ADDRESS(ES) Dr. Martin Nisenoff, Program officer, Code 6850.10 NRL (Naval Research Laboratory) 4555 Overlook Ave., SW Washington DC 20375-5326			10. SPONSORING/MONITORING AGENCY REPORT NUMBER	
11. SUPPLEMENTARY NOTES				
12a. DISTRIBUTION/AVAILABILITY STATEMENT Approved for public release			12b. DISTRIBUTION CODE	
13. ABSTRACT (Maximum 200 words)  During contract period, we have completed the technical objectives of this project. The highlights include (1) Made, for the first time, 3-pole HTS filters in MHz range on 2-inch wafers. (2) Achieved an insertion loss of -0.7 dB and a return loss of -15 dB. (3) Invented an active switchable tuning method for turnable HTS filter. Overall, 2 papers have been published, 3 submitted, 5 conference papers presented and 3 patent applications submitted.				
14. SUBJECT TERMS			15. NUMBER OF PAGES	
			16. PRICE CODE	
17. SECURITY CLASSIFICATION OF REPORT	18. SECURITY CLASSIFICATION OF THIS PAGE	19. SECURITY CLASSIFICATION OF ABSTRACT	20. LIMITATION OF ABSTRACT	

NSN 7540-01-280-5500

Standard Form 298 (Rev. 2-89)  
Prescribed by ANSI Std. Z39-18  
298-102