

**WTSETUP: Software for Creating
and Editing Configuration Files in
the Low Speed Wind Tunnel Data
Acquisition System**

Craig D. Edwards

DSTO-TN-0217

19991027 112

DISTRIBUTION STATEMENT A
Approved for Public Release
Distribution Unlimited

WTSETUP: Software for Creating and Editing Configuration Files in the Low Speed Wind Tunnel Data Acquisition System

Craig D. Edwards

**Air Operations Division
Aeronautical and Maritime Research Laboratory**

DSTO-TN-0217

ABSTRACT

The Data Acquisition System in the Low Speed Wind Tunnel is responsible for the measurement, recording, processing and displaying of wind tunnel test data. The system requires a number of initialisation files which define the test programme, model configuration, hardware setup and data reduction processes. Software titled WTSETUP has been developed which allows the operator to create and/or edit these configuration files via a user friendly, windows-based interface. This document enables a typical wind tunnel user to become familiar with the software and its operation and it defines the configuration file parameters commonly used in wind tunnel testing at the Aeronautical and Maritime Research Laboratory.

RELEASE LIMITATION

Approved for public release

DEPARTMENT OF DEFENCE
DEFENCE SCIENCE & TECHNOLOGY ORGANISATION

DSTO

Published by

*DSTO Aeronautical and Maritime Research Laboratory
PO Box 4331
Melbourne Victoria 3001 Australia*

*Telephone: (03) 9626 7000
Fax: (03) 9626 7999
© Commonwealth of Australia 1999
AR-011-055
August 1999*

APPROVED FOR PUBLIC RELEASE

WTSETUP: Software for Creating and Editing Configuration Files in the Low Speed Wind Tunnel Data Acquisition System

Executive Summary

The Data Acquisition System in the Low Speed Wind Tunnel at the Aeronautical and Maritime Research Laboratory is responsible for the measurement, recording, processing and displaying of wind tunnel test data. The system requires a number of initialisation files which define the test programme, model configuration, hardware setup and data reduction processes. These text files often need to be changed by the operator when setting up a new test and sometimes at regular stages during the test programme.

Software titled WTSETUP has been developed which allows the operator to create and/or edit wind tunnel configuration files via a user friendly, windows-based interface. The interface consists of a collection of menus, text boxes and switches, which allow the user to modify file parameters easily and avoid the chance of format errors. WTSETUP provides a simple and safe means of creating and/or modifying configuration files, and it has led to a large increase in wind tunnel productivity.

The software has been designed to be flexible so that in any future development, other configuration or initialisation files relating to the Low Speed Wind Tunnel Data Acquisition System may be incorporated into WTSETUP to provide an easier means of viewing and editing.

This document enables a typical wind tunnel user to become familiar with the software and its operation and it defines the configuration file parameters commonly used in wind tunnel testing.

Authors

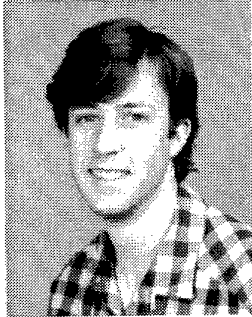

Craig D. Edwards
Air Operations Division

Craig graduated from the University of Queensland in 1995 completing a Bachelor of Mechanical and Space Engineering with First Class Honours. The following year he obtained employment with the Aeronautical and Maritime Research Laboratory at Melbourne. Working in Flight Mechanics, he has gained considerable experience in the area of wind tunnels and experimental aerodynamics including test programmes with the Hydrographic Ship and PC-9/A aircraft. He has also been involved extensively in the development of wind tunnel data acquisition systems.

Contents

1. INTRODUCTION.....	1
2. SOFTWARE STRUCTURE	1
3. WTSETUP EXECUTION AND MAIN MENU	2
3.1 Directory Structure Required	2
3.2 Execution and Main Menu	2
4. CONFIGURATION FILES	3
4.1 Configuration Data	5
4.1.1 Filename.....	5
4.1.2 Project Title.....	5
4.1.3 Customer Title	6
4.1.4 Description	6
4.1.5 Data Block Constant.....	6
4.1.6 Data Block Variable.....	6
4.1.7 File Constants and their Values.....	7
4.2 Model Parameters	7
4.2.1 Number of Control Surfaces	8
4.2.2 Reference Lengths and Areas	8
4.2.3 Powered Propeller.....	8
4.2.4 Source of Attitude Data	8
4.2.5 Balance Type	8
4.3 Balance Data.....	9
4.3.1 Balance Orientation.....	9
4.3.2 Balance Deflections	10
4.3.3 Model Attitude Offsets.....	10
4.3.4 Safe Loads.....	10
4.4 Interference Parameters	11
4.5 Balance Calibration File.....	12
4.6 Tareweights File	13
4.7 Output Format	14
4.8 Options.....	15
5. MONFRC INITIALISATION FILE	17
5.1 General.....	17
5.2 Gauges.....	19
5.3 Colours	21
6. CONCLUSIONS	23

7. REFERENCES	23
APPENDIX A: SAMPLE CONFIGURATION FILE.....	25

1. Introduction

The Data Acquisition System in the Aeronautical and Maritime Research Laboratory (AMRL) Low Speed Wind Tunnel (LSWT) involves the measurement, recording, processing and displaying of wind tunnel test data. Wind tunnel tests, for example force and moment measurement tests, require configuration files that contain information describing the setup and method of acquiring and computing the data. The display of wind tunnel data is achieved by MONFRC [Ref 1], which also requires an initialisation file that determines the format of the screen for the operator.

Both the configuration file and the MONFRC initialisation file, have an ASCII format and they may need to be edited frequently. As a result, a graphical user interface called WTSETUP was developed to enable easier viewing and editing of these files. Written in the C programming language with X/Motif libraries, the interface consists of a collection of user-friendly menus, text boxes, and switches, which allow the user to modify file parameters and reduce the chance of format errors. WTSETUP provides a simple and safe means of creating and/or modifying configuration files, and it has led to a large increase in wind tunnel productivity.

This document enables a typical wind tunnel user to become familiar with the WTSETUP software and its operation. It also describes the contents of the configuration file and the MONFRC initialisation file and it defines the parameters commonly used in wind tunnel testing at AMRL.

2. Software Structure

WTSETUP is a graphical user interface programmed in the C language with X/Motif libraries and it operates under a UNIX environment. The majority of the code was developed using a software package called Application Builder [Ref 2], which enables easy construction of graphical user interfaces. The application can be divided into modules and once the interface is assembled, Application Builder generates the C code and the Makefile. For each module created, the following two C files (and their corresponding header files) are generated:

1. *modulename_ui.c* - This file contains all of the widget construction functions and it must not be edited manually by the user if compatibility is to be maintained with Application Builder.
2. *modulename_stubs.c* - This file contains the functional code for the module. The user can edit this file manually in the appropriate locations to set up callback functions for button actions and to establish the contents of all of the data fields and widgets.

3. WTSETUP Execution and Main Menu

3.1 Directory Structure Required

For correct operation, WTSETUP requires the job directory structure created by DATAIN [Ref 3] for a particular wind tunnel test. In particular, the sub-directories of `./conf` and `./misc` are required. WTSETUP must be started in the main job directory to enable access to the following files:

1. MONFRC initialisation file, `monfrc.ini`, located in the `./misc` sub-directory. This file is usually common to an entire wind tunnel test programme.
2. Configuration files with extensions of `.dat`, located in the `./conf` sub-directory. An unlimited number of configuration files may exist in this directory as they can be opened and saved under user-chosen filenames.

3.2 Execution and Main Menu

The executable file for WTSETUP is located in the `~/bin` sub-directory under the home directory of user 'lswt' on BERNOULLI (a DEC AlphaServer 4/233 computer located in the Low Speed Wind Tunnel Control Room). WTSETUP can be started in one of the following two different ways:

1. Typing directly at the prompt in the job directory using a command with the following syntax,

```
wtsetup menu_picture.xpm
```

If the `menu_picture.xpm` file is ignored, the default picture, `wtsetup.xpm` located in the `~/bin` sub-directory will be used.

2. Manually clicking on the 'Configuration Builder' button via the DATAIN user interface [Ref 3] once a job directory has been selected.

Upon starting WTSETUP the operator will be presented with an introductory menu located beneath a picture, as shown in Figure 1. There are two options currently available in this menu and they are the types of files the user can create or modify as follows:

1. *Configuration Files* define the parameters for a wind tunnel test programme.
2. *Monfrc Initialisation File* defines the parameters that customise the display of wind tunnel data [Ref 1].

The following sections describe the content and format of these types of files.

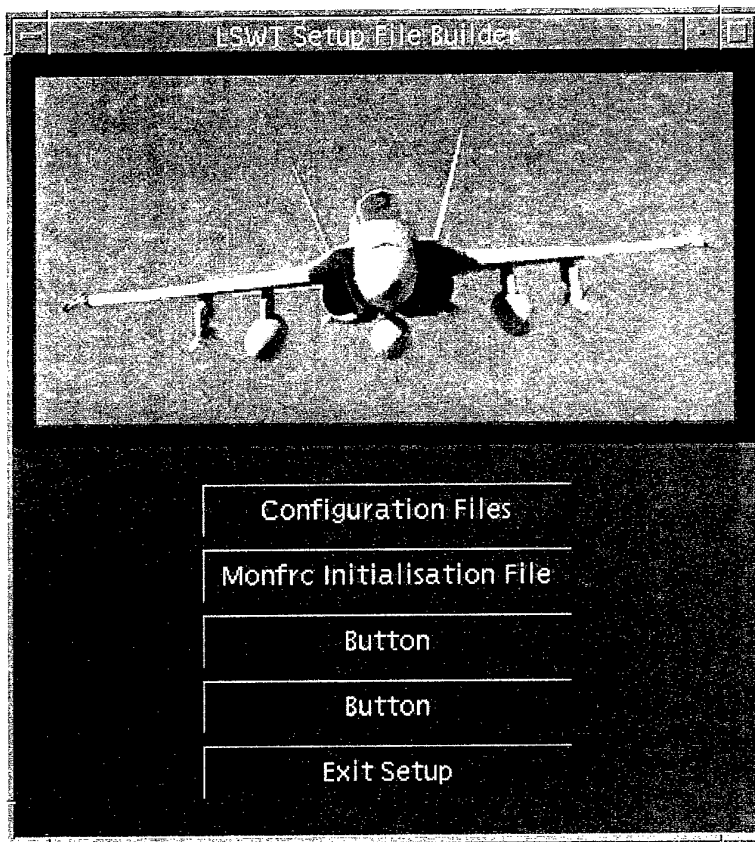

Figure 1. Main menu of WTSETUP

4. Configuration Files

Configuration files contain information that is specific to a particular wind tunnel test programme. This information determines the wind tunnel data to be acquired, how it is to be acquired and how it is to be processed and recorded. This software allows the user to create new configuration files or to modify certain parameters in existing files.

When the configuration files option is selected from the main menu, the user is presented with a dialog window as shown in Figure 2. The top section of this window contains a collection of 'buttons', each corresponding to a different 'page' of data. When a button is selected the appropriate page of data is displayed in the middle section of this window. All of this data is contained in each configuration file, a sample of which is listed in Appendix A. The contents of each page of data and the information in the configuration file are described in the following sections.

Create/Modify a Configuration File			
Configuration Data	Model Parameters	Balance Data	Interference Parameters
Balance Calibration File	Tareweights File	Output Format	Options
Filename: /usr/users/lswt/task/pc9-may99/conf/conf001.dat			
Project Title: PC9 Force and Moment Tests - May 1999			
Customer Title: AOD - AMRL			
Description:			
PC-9 Clean Configuration 1			
Power OFF -2/-2 Empennage ON Undercarriage OFF			
Tailplane setting Angle -2.15 Horizontal Strake setting angle -1.0			
Flap 0 Aileron 0/0			
Elevator var Rudder 0			
Data Block Constant:	dele		
Data Block Variable:	Alpha		
File Constant 1:	nt	Value: I	-2.15
File Constant 2:	NONE	Value: I	
File Constant 3:	NONE	Value: I	
File Constant 4:	NONE	Value: I	
NEW		OPEN	
SAVE		EXIT	

Figure 2. Configuration Data page for the Configuration File Editor

Along the bottom edge of the window there are four buttons which have the following actions:

1. **NEW** - This button clears all data on every page allowing the user to enter information for a new configuration file from scratch.
2. **OPEN** - This button generates a file dialog window as shown in Figure 3, which allows the user to select an existing configuration file from a particular directory. The default directory is the `./conf` sub-directory located immediately beneath the current job directory. When a file is chosen, the information contained in this configuration file is then entered into the appropriate fields on each page of data. The user can then modify any parameter as required.
3. **SAVE** - This button saves all of the data in each page and writes it to the configuration filename specified on the Configuration Data page. If the file exists a warning dialog will appear to question the user before overwriting the original configuration file.

4. **EXIT** - This button exits the Configuration File Builder section of WTSETUP and returns the user to the main menu.

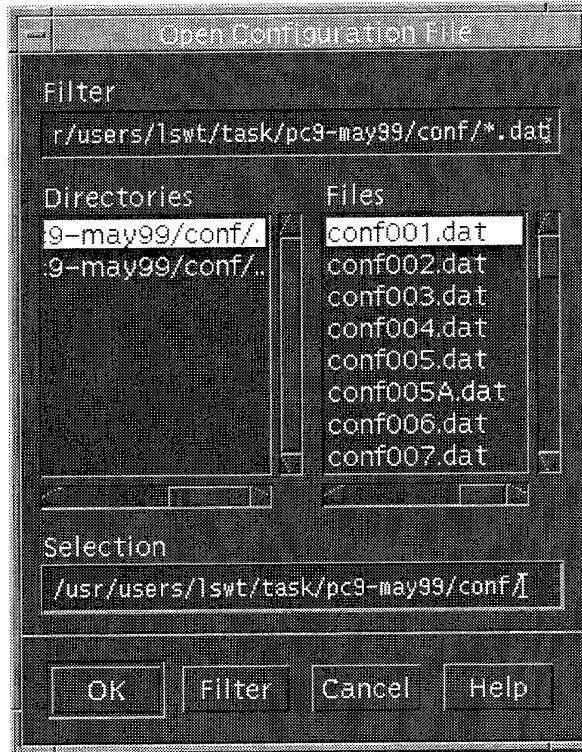

Figure 3. Open file dialog window after an 'OPEN' in the Configuration File Editor

4.1 Configuration Data

The contents of the Configuration Data page are shown in Figure 2.

4.1.1 Filename

This text field has a maximum length of 100 characters and it contains the entire path and filename of the configuration file that is currently open. This filename can be edited to save the configuration file contents to a different file.

4.1.2 Project Title

This text field contains the title of the wind tunnel project or test programme and it may be up to 100 characters in length.

4.1.3 Customer Title

This text field contains the customer of the wind tunnel project or test programme and it may be up to 100 characters in length.

4.1.4 Description

This text field contains five lines describing the wind tunnel test and/or associated configuration file. Each line has a maximum length of 80 characters.

4.1.5 Data Block Constant

Individual test points in a test data file are grouped into "blocks". The data block constant is the parameter that remains at a constant value for each test point in a particular block of data. It is selected from the pop down menu, which currently contains the parameters shown in Table 1.

Table 1. Parameters available for the data block constant, data block variable, and file constants contained in the pop-down menus.

Menu Option	Parameter	Units
Vel	Velocity	ms ⁻¹
Renum	Reynolds Number	no units
Theta	Theta	degrees
Phi	Phi	degrees
Psi	Psi	degrees
Alpha	Alpha	degrees
Beta	Beta	degrees
dele	Elevator Angle	degrees
delr	Rudder Angle	degrees
nt	Tailplane Angle	degrees
ct	Thrust Coefficient	no units
cq	Torque Coefficient	no units
RPS	Propeller Speed	revs/sec
blade angle	Propeller Blade Angle	degrees

4.1.6 Data Block Variable

The data block variable is the parameter whose value changes most frequently in each block of data. It is selected from the pop down menu, which currently contains the parameters shown in Table 1.

4.1.7 File Constants and their Values

The file constants are those parameters that are forced to have constant values for the entire test data file. Up to four file constants and their values can be specified in the configuration file for a particular test. The file constants are selected from the pop down menus, which currently contain the parameters shown in Table 1. The values of the file constants are entered in the relevant text fields with the appropriate units.

4.2 Model Parameters

The contents of the Model Parameters page are shown in Figure 4.

Create/Modify a Configuration File			
Configuration Data	Model Parameters	Balance Data	Interference Parameters
Balance Calibration File	Tareweights File	Output Format	Options
Number of Control Surfaces: <input type="text" value="0"/>			
Reference Lengths and Areas:			
		Mean Chord (m):	<input type="text" value="0.2845"/>
		Span (m):	<input type="text" value="1.7455"/>
		Reference Area (m ²):	<input type="text" value="0.4842"/>
		Reynold's Number Reference Length (m):	<input type="text" value="0.2845"/>
<hr/>			
<input checked="" type="checkbox"/> Power Propeller		Propeller Diameter (m):	<input type="text" value="0.3810"/>
<hr/>			
Source of Attitude Data:			
<input type="radio"/> Theta/Phi from Accelerometer		Balance Type:	
<input type="radio"/> Theta/Phi from Sting Column Rig			
<input type="radio"/> Theta/Phi from External Balance Digitisers			
<input checked="" type="radio"/> Theta from Accelerometer, Psi from Turntable			
<input type="radio"/> Theta/Phi from Test Schedule File			
<input type="radio"/> Theta/Psi from Test Schedule File			
<input type="radio"/> Internal		<input type="radio"/> External	
<input type="button" value="NEW"/> <input type="button" value="OPEN"/> <input type="button" value="SAVE"/> <input type="button" value="EXIT"/>			

Figure 4. Model Parameters page for the Configuration File Editor

4.2.1 Number of Control Surfaces

The number of movable control surfaces on the wind tunnel model is entered using the arrows on the spinbox. This parameter is obsolete in the current data acquisition system, and is retained for backward capability.

4.2.2 Reference Lengths and Areas

In order to calculate aerodynamic coefficients and the correct Reynolds Number, the following geometry of the wind tunnel model is required:

- Mean Chord (m)
- Span (m)
- Reference Area (m²)
- Reynolds Number Reference Length (m)

Each of these parameters is entered in the appropriate text field.

For general wind tunnel tests involving a model other than an aircraft, these parameters can be used to input data appropriate to the type of model.

4.2.3 Powered Propeller

If the wind tunnel model has a powered propeller then this checkbox should be activated. It also requires the user to enter the propeller diameter in *metres* in the appropriate text field.

4.2.4 Source of Attitude Data

A selection must be made from the following list to identify the source of the wind tunnel model attitude information.

- Theta/Phi from Accelerometer;
- Theta/Phi from Sting Column Rig;
- Theta/Phi from External Balance Digitisers;
- Theta from Accelerometer, Psi from Turntable;
- Theta/Phi from Test Schedule File; or
- Theta/Psi from Test Schedule File.

where Psi, Theta, Phi are Yaw, Pitch, Roll respectively.

4.2.5 Balance Type

The user must identify whether the balance being used is of the internal (strain gauge) or external (underfloor/mechanical balance) type.

4.3 Balance Data

The contents of the Balance Data page are shown in Figure 5.

Create/Modify a Configuration File			
Configuration Data	Model Parameters	Balance Data	Interference Parameters
Balance Calibration File	Tareweights File	Output Format	Options
Balance Orientation:			
X: [0.03200]	Y: [0.00000]	Z: [0.05220]	
Theta: [0.00000]	Psi: [0.00000]	Phi: [0.00000]	
Balance Deflections:			
Bdef 1: [0.00000]	Bdef 2: [0.00000]	Bdef 3: [0.00000]	
Bdef 4: [0.00000]	Bdef 5: [0.00000]		
Model Attitude Offsets:			
Theta: [0.00000]	Psi: [0.00000]	Phi: [0.00000]	
Safe Loads (lb/lbft):			
X: [250.00]	Y: [350.00]	Z: [700.00]	
l: [250.00]	m: [200.00]	n: [100.00]	
NEW	OPEN	SAVE	EXIT

Figure 5. Balance Data page for the Configuration File Editor

4.3.1 Balance Orientation

The orientation of the model with respect to the balance must be known and input on this page. The linear position of the model moment centre with respect to the balance moment centre is entered as X, Y and Z displacements in the appropriate text fields with units of *metres*. The sign convention for the displacements is given in Figure 6. The angular offsets of the model body axes system with respect to the balance axes system are entered as Theta, Psi and Phi (pitch, yaw, roll) in the appropriate text fields with units of *degrees*.

4.3.2 Balance Deflections

The five elements of the balance deflection matrix, B_{def1} , B_{def2} ... B_{def5} , are entered in the appropriate text fields. A description of these parameters is given in Reference 4.

4.3.3 Model Attitude Offsets

The values of yaw, pitch and roll angles indicated by the model attitude or support rig readouts must be corrected for angular offsets between the model attitude or support rig zero datums and the tunnel axes system. The model attitude offsets are the angular offsets from the tunnel axes to the support rig zero datums and these must be input on this page. The values for these offsets in the Theta, Psi, and Phi directions are entered in the appropriate text fields with units of *degrees*. In most cases, these values are zero.

4.3.4 Safe Loads

The safe loads are the maximum design loads that may be applied to the internal strain gauge (or external) balance. These values should be entered in the relevant text fields with units that are consistent with the balance calibration units (see Section 4.5).

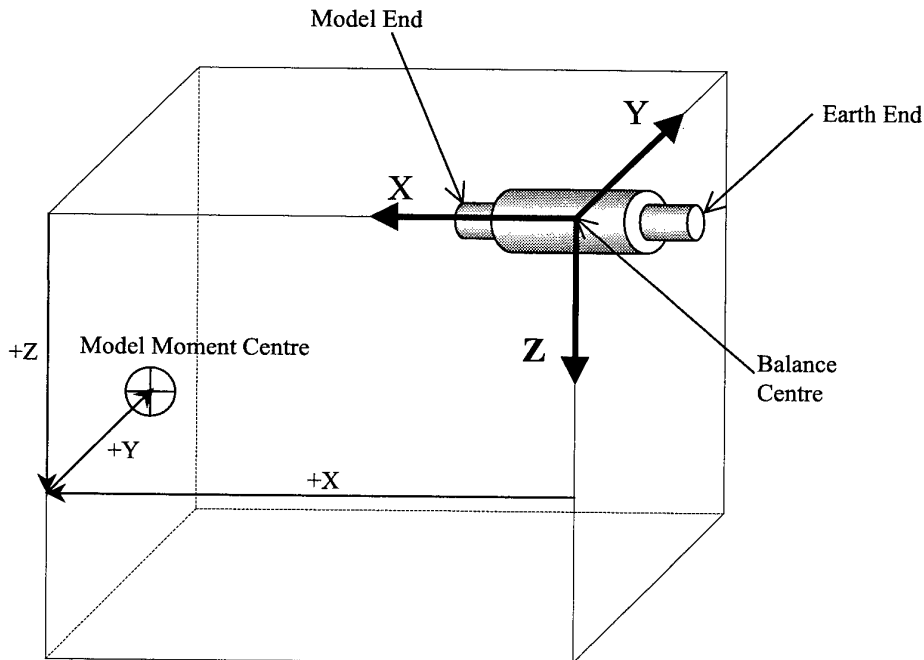

Figure 6. Sign definition for the location of the model moment centre with respect to the balance centre

4.4 Interference Parameters

The contents of the Interference Parameters page are shown in Figure 7.

Configuration Data	Model Parameters	Balance Data	Interference Parameters
Balance Calibration File	Tareweights File	Output Format	Options
<input checked="" type="checkbox"/> Wind Tunnel Corrections Required?			
K1: 1.00000			
K3: 0.92500			
VOL Wing (m ³): 0.01033			
VOL Fuselage (m ³): 0.03406			
TAU1 Wing: 0.86500			
TAU1 Body: 0.85000			
TAU2 Wing: 0.11000			
TAU2 Tailplane: 0.76000			
DELTA1: 0.11500			
CDO Estimate: 0.03000			
WLCS Estimate: 0.07600			
NEW	OPEN	SAVE	EXIT

Figure 7. Interference Parameters page for the Configuration File Editor

If wind tunnel corrections are to be applied to the data then the 'Wind Tunnel Corrections Required?' checkbox should be activated. It also requires the user to enter into the appropriate text fields the interference parameters for calculating blockage and lift interference. These parameters are applicable to a typical aircraft model but they may be used as a basis to input interference data appropriate to other types of wind tunnel models.

Details and definitions of the following interference parameters and appropriate values are given in *Pope and Rae* [Ref 5]. Briefly, they are:

- K1 – blockage factor for the wing
- K3 – blockage factor for the fuselage

- VOL Wing (m³) - volume of the wing
- VOL Fuselage (m³) - volume of the fuselage
- TAU1 Wing - lift interference factor for the wing
- TAU1 Body - lift interference factor for the fuselage
- TAU2 Wing - lift interference factor for the wing
- TAU2 Tailplane - lift interference factor for the tailplane
- DELTA1 - tunnel lift interference factor
- CD0 Estimate - estimate of model zero lift drag
- WLCS Estimate - estimate of the wing lift curve slope

4.5 Balance Calibration File

The contents of the Balance Calibration File page are shown in Figure 8.

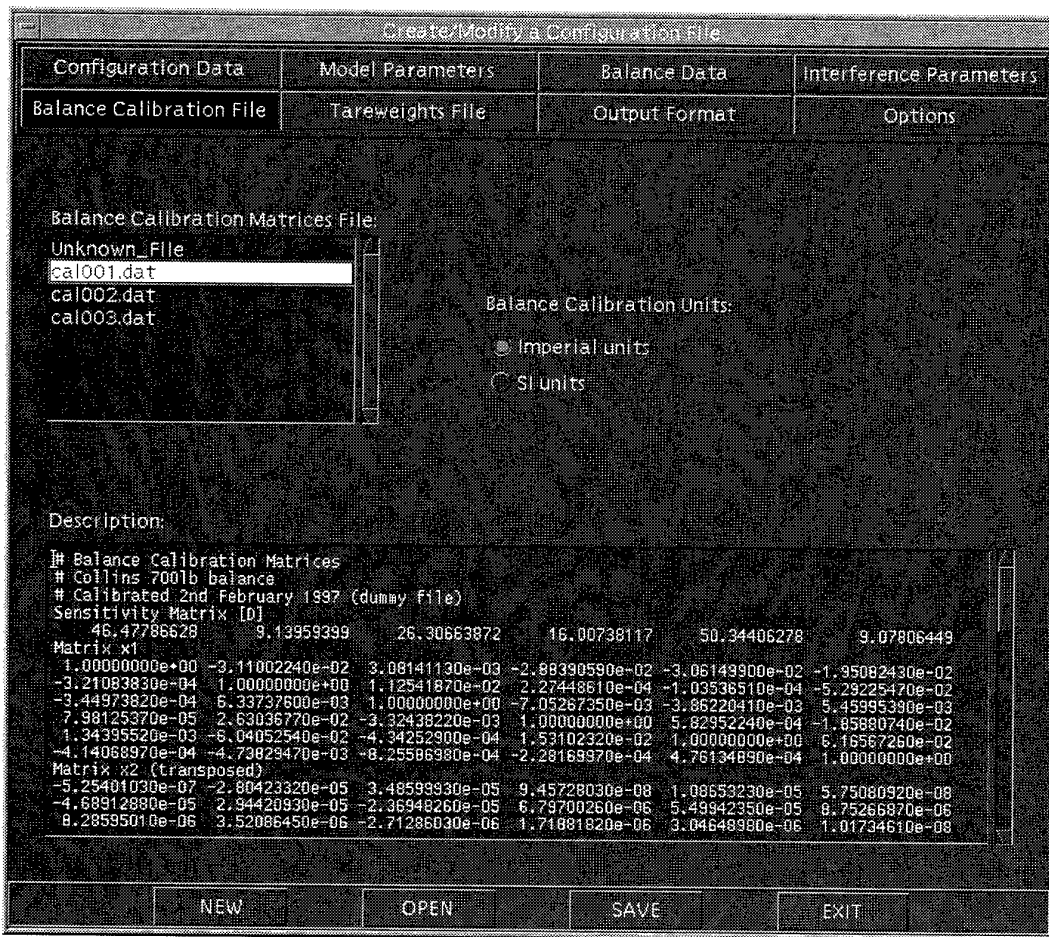

Figure 8. Balance Calibration File page for the Configuration File Editor

All of the balance calibration matrices files from the `./calfiles` sub-directory are displayed in the listbox. When a particular file is selected, its contents are displayed automatically in the window below the listbox. This includes the calibration matrices and description lines detailing the calibration. When a configuration file is saved, the balance calibration filename *and* the matrices it contains are copied to the configuration file. This allows the test results to be easily traced to a particular balance calibration and it is important when balances are recalibrated. If an existing configuration file does not contain the balance calibration filename, *Unknown_File* will be highlighted in the listbox. In this case, when a configuration file is saved, the balance calibration matrices currently displayed in the window will be used.

The user must also select the units (SI or imperial) in which the calibration matrix was generated. The balance safe loads must also be entered with these same units (see Section 4.3.4).

4.6 Tareweights File

The contents of the Tareweights File page are shown in Figure 9.

Tareweight files are created during online tareweight measurements, and they have extensions of `.out`, and are located in the `./results` sub-directory.

Each file contains the following:

- Several lines of description identifying the nature of the tareweights file for a particular configuration. The first character of each line is a hash '#' (to indicate a comment line).
- A number of lines of data associated with the iterative calculation procedure for the tareweights.
- The last line in the file contains the nine coefficients of the model tareweight matrix [Ref 4].

All of the files, including the tareweight files, from the `./results` sub-directory are displayed in the tareweights file listbox. When a particular file is selected, its contents are displayed automatically in the window below the listbox. When a configuration file is saved, the tareweights filename *and* the actual nine tareweight values are copied to the configuration file. If an existing configuration file does not contain the tareweights filename, *Unknown_File* will be highlighted in the listbox. In this case, when a configuration file is saved, the nine tareweight values currently displayed in the window will be used.

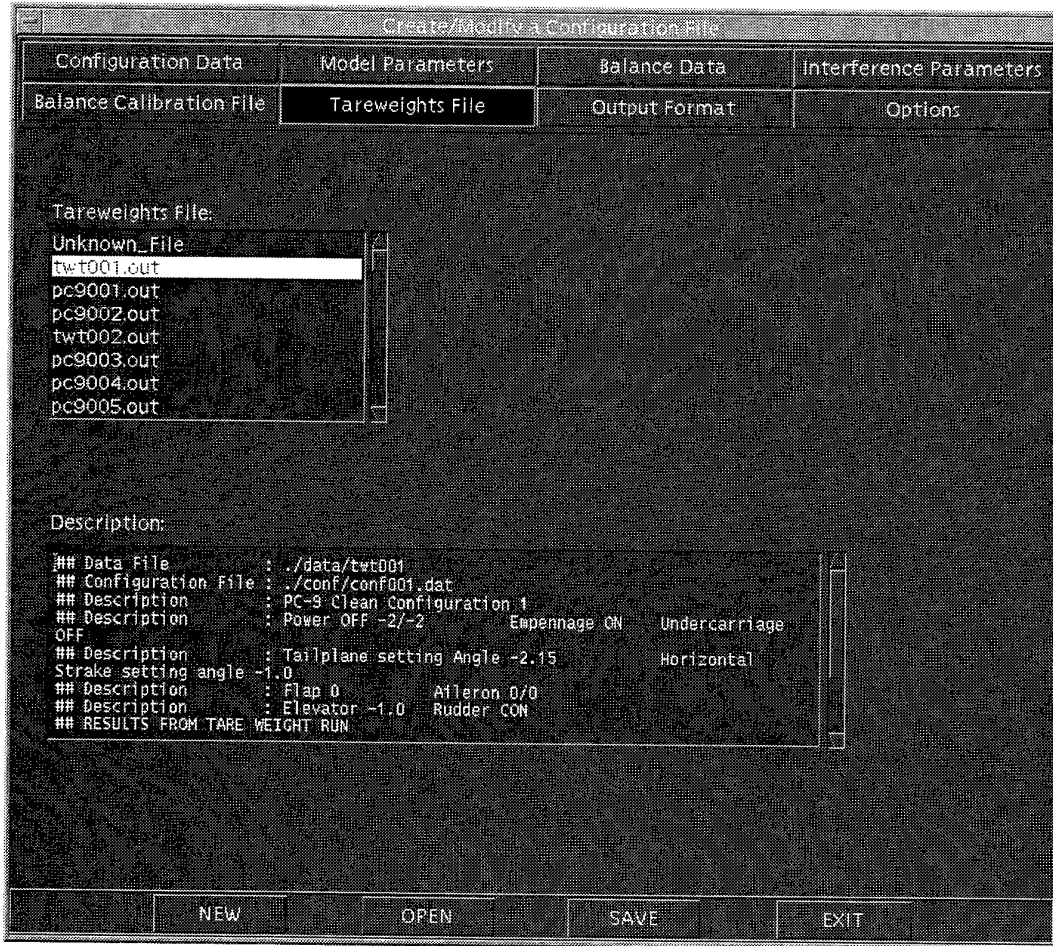

Figure 9. Tareweights File page for the Configuration File Editor

4.7 Output Format

The contents of the Output Format page are shown in Figure 10.

The checkboxes activated on this page determine which parameters are to be printed in the final output file. Uncorrected data refers to the data without wind tunnel corrections applied (see Section 4.4). If the uncorrected data is required in the final output file in addition to the corrected data, then the 'Uncorrected Data' checkbox should also be activated.

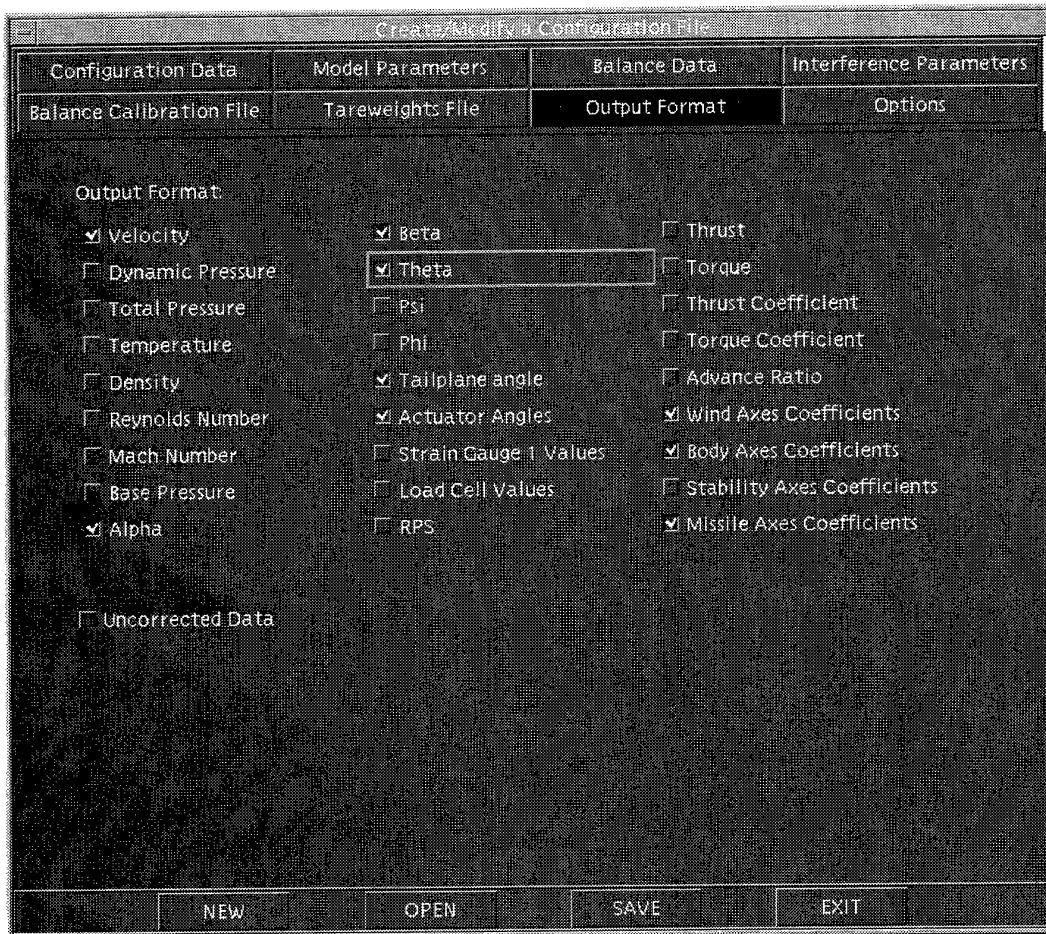

Figure 10. Output Format page for the Configuration File Editor

4.8 Options

The Options page, shown in Figure 11, contains other options available in a wind tunnel test programme.

If base pressure is being measured and this data is required then the corresponding checkbox should be activated.

Data sampling involves the recording of multiple data samples for each test point. If data sampling is required, the corresponding checkbox should be activated and the number of sample points entered in the text field. Using this technique, averaged results are obtained which reduce any instability that may exist in the measurements. Additionally, statistical information for the data will be calculated and automatically stored in the `./stat` sub-directory, showing the standard deviation of data for each test point.

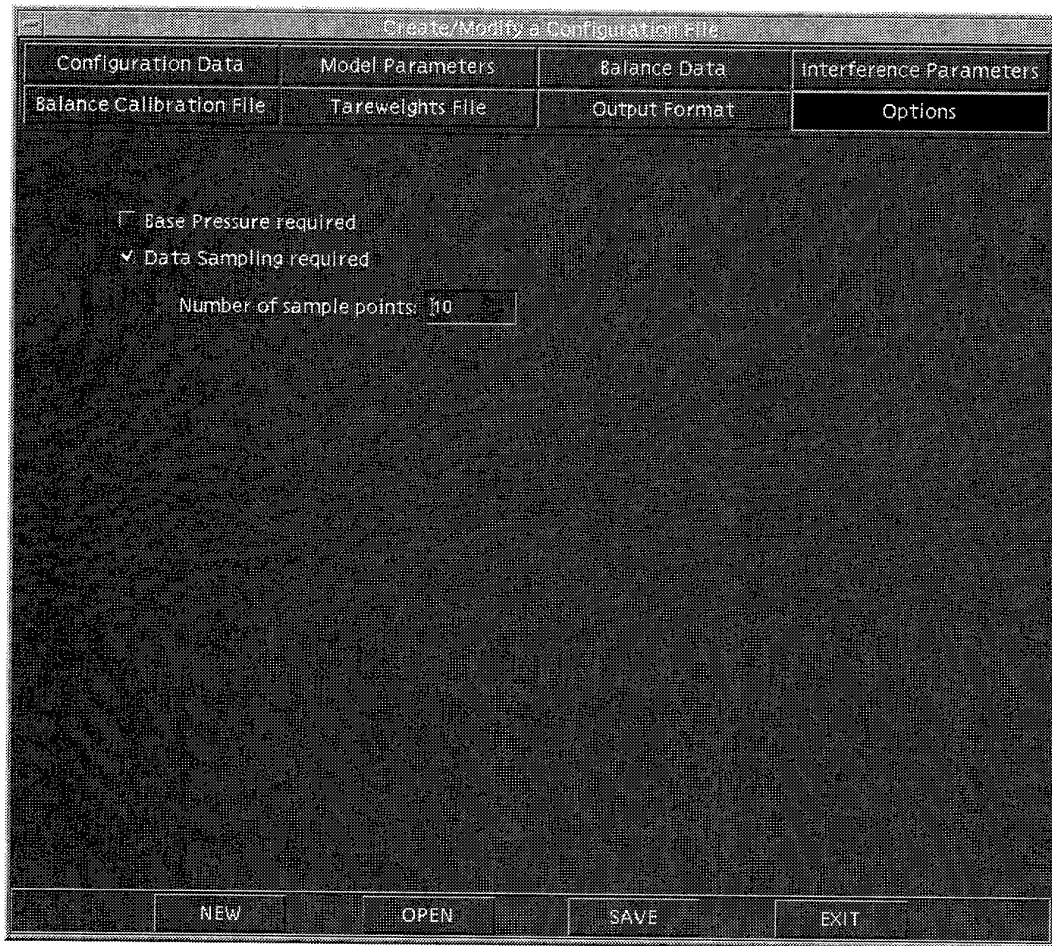

Figure 11. Options page for the Configuration File Editor

5. MONFRC Initialisation File

The MONFRC initialisation file, `monfrc.ini`, contains information regarding the display of wind tunnel data on the screen using graphical "gauges" [Ref 1]. This information includes which parameters are to be displayed and the gauge display properties, such as lower and upper limit values and warning limits. This editor allows the user to modify the MONFRC initialisation file.

When the MONFRC initialisation file option is selected from the main menu, the user is presented with a dialog window, as shown in Figure 12. The top section of this window contains a collection of 'buttons', each corresponding to a different 'page'. When a button is selected the appropriate page of data is displayed in the middle section of this window. All of this data is contained in the MONFRC initialisation file, located in the `./misc` sub-directory.

Along the bottom edge of the window there are three buttons which have the following actions:

1. **APPLY** - This button applies any changes made to the Gauges data page (see Section 5.2) by saving them in memory.
2. **SAVE TO FILE** - This button saves all of the data in each page and writes it to the MONFRC initialisation file, `monfrc.ini`, located in the `./misc` sub-directory.
3. **EXIT** - This button exits the MONFRC initialisation file section of WTSETUP and returns the user to the main menu.

The contents of each page of data are described in the following sections. For a detailed explanation of the parameters in the MONFRC initialisation file, refer to the MONFRC report [Ref 1].

5.1 General

The contents of the General page are shown in Figure 12.

The model type simply determines the graphic to be displayed on some of the gauges that display the test conditions and data. Presently, the options available for selection are the PC-9/A and the F/A-18 aircraft, or MK-82 Bomb. Other graphics can be added as required.

The model attitude and orientation gauges in MONFRC can be displayed according to the source of attitude data defined in the configuration file, or overridden using the information defined in the MONFRC initialisation file.

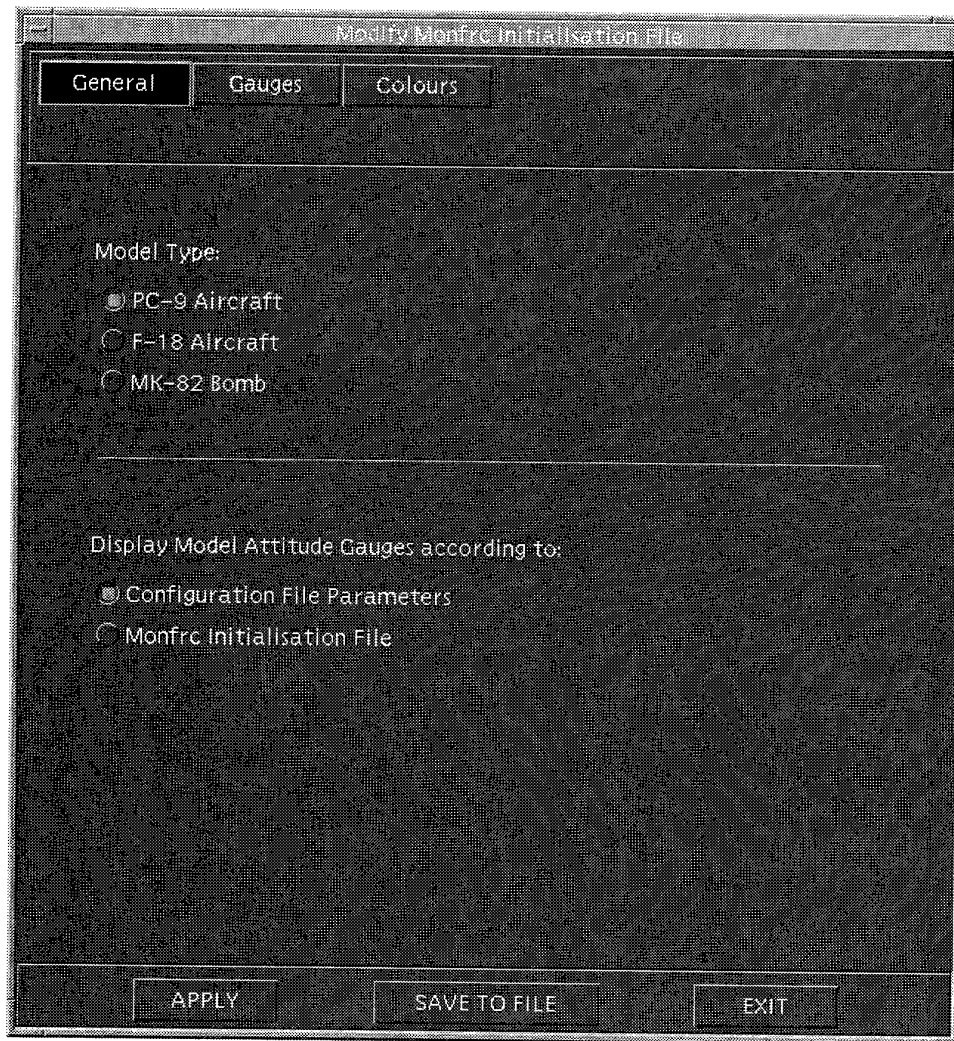

Figure 12. General page for the MONFRC Initialisation File Editor

5.2 Gauges

The contents of the Gauges page are shown in Figure 13.

Modify MONFR Initialisation File

General Gauges Colours

Gauge: Pitch Angle

Title: Theta

Display: ON OFF

Position: X: 585 Y: 550

Gauge Range: Min: -16.00 Max: 24.00

Lower Alarm Limits: Yellow: -7.00 Red: -8.00

Upper Alarm Limits: Yellow: 21.00 Red: 22.00

APPLY SAVE TO FILE EXIT

Figure 13. Gauges data page for the MONFR Initialisation File Editor

The pop down menu located on this page contains the gauges available in MONFR. For a detailed description of the appearance and functionality of these gauges, please refer to the MONFR report [Ref 1].

Each available gauge is listed below with the units of the parameter that each gauge displays:

- Velocity in the tunnel test section (ms^{-1})
- Tunnel Test Section Static Pressure (kPa)
- Temperature in the test section ($^{\circ}\text{C}$)
- Dynamic Pressure in the test section (Pa)
- Reynolds Number
- Mach Number of the flow in the test section
- Pitch Angle of the model (degrees)
- Roll Angle of the model (degrees)
- Yaw Angle of the model (degrees)
- Additional Angle 1 (degrees)
- Additional Angle 2 (degrees)
- Strain Gauge Balance (or external balance) Loads 1 (loads as a percentage of balance safe loads)
- Actuator Angles (control surface angles) (degrees)
- RPS of a propeller on a powered aircraft model (revolutions per second)

When a gauge is selected, its characteristics are displayed in the data fields located beneath the pop down menu. Each of these characteristics can be modified as follows:

- The display of the gauge can be switched to either ON or OFF.
- The gauge range is set by entering the lower and upper absolute limits of the gauge in the appropriate text fields. The units of the parameter displayed on the gauge are defined above.
- Display gauges have alarms to alert operators. The lower alarm limits are the values at which the operator receives a first warning (usually yellow) and a final warning (usually red) when the parameter is towards the lower end of its gauge range. These values are entered in the appropriate text fields and have the units defined above.
- The upper alarm limits are the values at which the operator receives a first warning (usually yellow) and a final warning (usually red) when the parameter is towards the upper end of its gauge range. These values are entered in the appropriate text fields and have the units defined above.

NOTE: If changes have been made to the properties of a particular gauge, the 'Apply' button must be activated to save the changes.

If a gauge property is modified and a different gauge is subsequently selected without applying the changes, a warning dialog will appear to prompt you to save or cancel these changes.

5.3 Colours

The contents of the Colours page are shown in Figure 14.

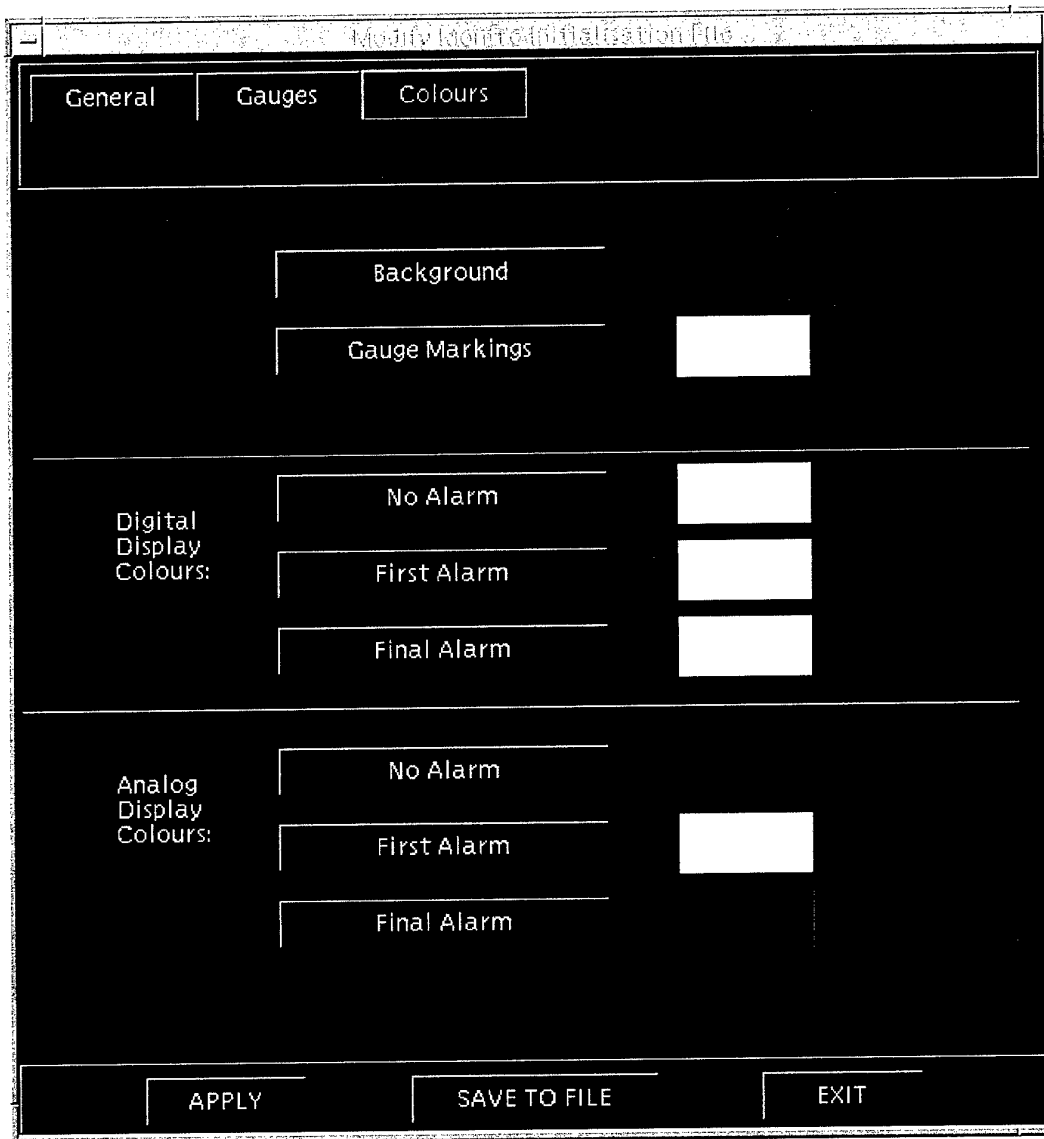

Figure 14. Colours page for the MONFRC Initialisation File Editor

The colours of the MONFRC screen that can be changed are:

- the background colour of the screen;
- the colour of the gauge markings;

- the colours of the digital portions of the display (or text values of the gauges) during the conditions of no alarm, first alarm and final alarm; and
- the colours of the analog portions of the display (or graphical parts of the gauges) during the conditions of no alarm, first alarm and final alarm.

For each of these items, a sample of the current colour is provided on the window, as shown in Figure 14. When the item's button is activated, a colour window dialog appears with three slider bars, as shown in Figure 15. Each slider bar corresponds to the Red, Green and Blue content of a particular colour. A new colour can be selected by sliding these bars, observing the result in the window above, and then activating the OK button.

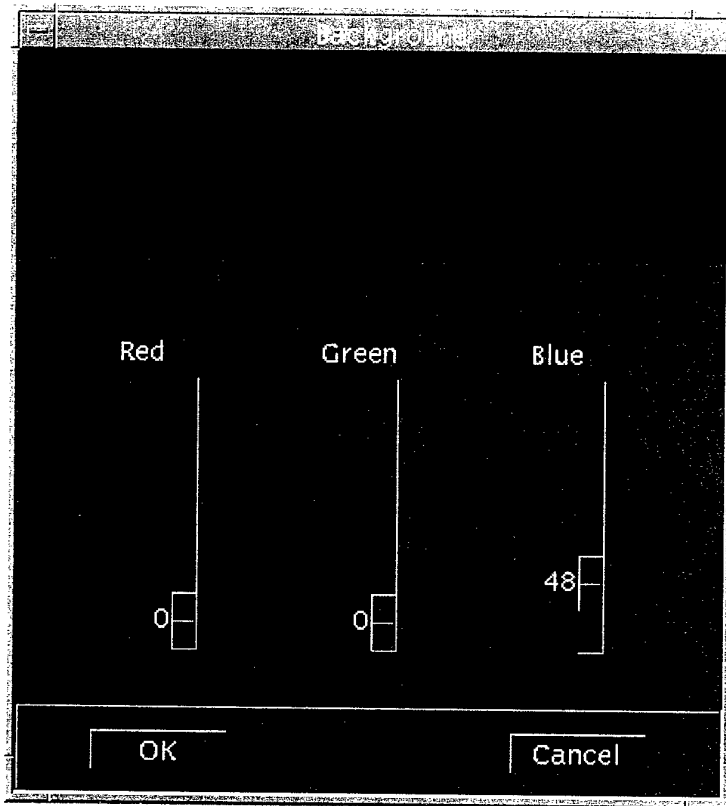

Figure 15. Change Colour Dialog Window for the MONFRC Initialisation File Editor

6. Conclusions

A software package called WTSETUP has been developed for the Low Speed Wind Tunnel Data Acquisition System. It provides a graphical user interface to enable configuration files and the MONFRC [Ref 1] initialisation file to be easily viewed, created and edited. Parameters in these files can be safely modified via a collection of user-friendly menus, text boxes and switches. This reduces the chance of format errors and it increases tunnel productivity.

This document enables a typical wind tunnel user to become familiar with the WTSETUP software and its operation. It also describes the contents of the configuration file and MONFRC initialisation file and provides definitions of the parameters commonly used in wind tunnel testing.

The software has been designed to be flexible so that in any future development, other configuration or initialisation files relating to the Low Speed Wind Tunnel Data Acquisition System may be incorporated into WTSETUP to provide an easier means of viewing and editing.

7. References

1. Edwards, C., (to be published), *MONFRC: Software for the Graphical Display of Parameters and Data in the Low Speed Wind Tunnel*, Aeronautical and Maritime Research Laboratory, Defence Science and Technology Organisation, Department of Defence, Australia.
2. Compaq Computer Cooperation, (1996), *Digital Unix Version 4.0E Documentation*, "Common Desktop Environment: Application Builder User's Guide", Order No. AA-QTM1A-TE, Digital Equipment Cooperation, Maynard, Massachusetts.
3. Edwards, C., Lam, S., Link, Y., (to be published), *DATAIN: Performing Low Speed Wind Tunnel Tests Using the New Data Acquisition System*, Aeronautical and Maritime Research Laboratory, Defence Science and Technology Organisation, Department of Defence, Australia.
4. Fairlie, B.D., (1985), *Algorithms for the Reduction of Wind-Tunnel Data Derived From Strain Gauge Force Balances*, Aeronautical and Maritime Research Laboratory, Defence Science and Technology Organisation, Department of Defence, Australia, Aerodynamics Report 164.
5. Rae, Jr, W.H. and Pope, A., (1984), *Low-Speed Wind Tunnel Testing*, 2nd Edition, John Wiley & Sons, Inc., Canada.

Appendix A: Sample Configuration File

```

#Title
PC9 Force and Moment Tests - May 1999
#Customer
AOD - AMRL
#Description Lines
PC-9 Clean Configuration 1
Power OFF -2/-2      Empennage ON      Undercarriage OFF
Tailplane setting Angle -2.15      Horizontal Strake setting angle -1.0
Flap 0      Aileron 0/0
Elevator var      Rudder 0
#Config
%konfig, test point number
1 1
#File Constants
NT -2.150000
#Data Block Constant
DELE 0.0000
#Data Block Variable
ALPHA
#Aerodynamic Constants
%chord (c), span(b), area(S), Reynolds No length (L)
0.2845 1.7455 0.4842 0.2845
#Interference Parameters
1.000 0.01033 0.925 0.03406 0.885
0.850 0.030 0.115 0.110 0.760 0.076
#Number of Surfaces
0
#Power
%BooL, auxiliary channel No, Prop Diameter
1 4 0.381000
#Mount Type
%mount, nangle
1 4
#Balance Data
%xbal, ybal, zbal, thbal, psibal, phibal
0.03200 0.00000 0.05220 0.00000 0.00000 0.00000
#Sensor Attitude Offsets
%theta0, psi0, phi0
0.00000 0.00000 0.00000
#Balance Calibration Matrix
Unknown_File
#Balance Calibration Imperial Units?
1
#Sensitivity Matrix [D]
46.47786628 9.13959399 26.30663872 16.00738117 50.34406278 9.07806449
#Matrix x1
1.00000000e+00 -3.11002240e-02 3.08141130e-03 -2.88390590e-02 -3.06149900e-02 -1.95082430e-02
-3.21083830e-04 1.00000000e+00 1.12541870e-02 2.27448610e-04 -1.03536510e-04 -5.29225470e-02
-3.44973820e-04 6.33737600e-03 1.00000000e+00 -7.05267350e-03 -3.86220410e-03 5.45995390e-03
7.98125370e-05 2.63036770e-02 -3.32438220e-03 1.00000000e+00 5.82952240e-04 -1.85580740e-02
1.34395520e-03 -6.04052540e-02 -4.34252900e-04 1.53102320e-02 1.00000000e+00 6.16567260e-02
-4.14068970e-04 -4.73829470e-03 -8.25586980e-04 -2.28169970e-04 4.76134890e-04 1.00000000e+00
#Matrix x2 (transposed)
-5.25401030e-07 -2.80423320e-05 3.48599930e-05 9.45728030e-08 1.08653230e-05 5.75080920e-08
-4.68912880e-05 2.94420930e-05 -2.36948260e-05 6.79700260e-06 5.49942350e-05 8.75266870e-06
8.28595010e-06 3.52086450e-06 -2.71286030e-06 1.71881820e-06 3.04648980e-06 1.01734610e-08
-1.65249200e-05 1.02240520e-05 -1.25545640e-05 -3.22683510e-08 8.63169750e-06 -1.97051580e-06
6.34679970e-06 5.78823080e-07 -5.53293670e-07 4.78319340e-07 3.98608360e-06 6.90451860e-09
-8.92549280e-06 1.87761780e-05 -1.53425690e-05 5.89936750e-06 -7.28805090e-05 8.64939700e-07
-1.22005300e-06 2.78333420e-06 -2.19639520e-06 -1.64163990e-06 9.74604400e-06 -2.52888300e-06
2.60249710e-06 6.63760780e-07 -6.57649590e-06 6.53077210e-07 3.78190850e-06 -3.72895370e-06
-3.05506010e-06 -1.18465340e-06 9.32519700e-07 1.57851240e-05 -2.19038900e-05 3.94636250e-07
6.94991780e-06 -9.84372080e-07 7.69681230e-07 4.16741350e-06 -8.69015190e-06 1.09087900e-07
1.32976870e-06 -1.96861230e-05 5.18525580e-05 -1.37256880e-06 1.26905860e-05 1.80604400e-05
6.09969030e-07 -3.84841860e-07 1.52893110e-06 -1.07887760e-05 4.66321640e-05 5.26479950e-06
-7.19070560e-06 -7.62917480e-06 2.23714120e-05 -4.59837410e-06 -1.11871260e-05 5.11400940e-05
-6.01717380e-07 -7.86811660e-08 -6.20574720e-05 -1.07703950e-06 5.24777340e-06 -7.90282780e-06
-3.95222880e-05 8.09635940e-06 -1.22970480e-05 -4.00233030e-05 9.25818660e-05 -4.32870030e-06
6.87971860e-07 5.43231560e-06 6.04587810e-06 2.76948220e-07 1.82919420e-05 1.31920870e-06
-7.31201020e-08 2.51283570e-06 -1.15935240e-06 -1.58843300e-07 -1.23832960e-06 -2.69103870e-07
-2.78766190e-05 -4.20548750e-06 2.68640620e-06 -1.67760210e-06 -4.03447910e-06 4.37762010e-06
2.30309240e-05 3.97958980e-07 -1.99509510e-06 2.77218460e-06 -7.94017170e-06 -3.74472360e-07
3.95607780e-06 -6.78028040e-06 3.86769390e-06 1.16623070e-07 3.26881450e-06 -4.46471160e-06
-7.11871130e-07 -3.85654910e-06 -6.27011600e-06 2.68619620e-07 -9.78182460e-06 -7.11643760e-07

```

```

#Inverse of x1
9.99974103e-01 3.23162185e-02 -3.32110869e-03 2.83439072e-02 3.05787287e-02 1.98776018e-02
3.39232030e-04 1.00034302e+00 -1.12162655e-02 -2.85452721e-04 4.55691494e-05 5.30004432e-02
3.34777496e-04 -6.30587679e-03 1.00009003e+00 7.00378813e-03 3.87087262e-03 -5.89611601e-03
-7.90917599e-05 -2.62838948e-02 3.63452743e-03 1.00004217e+00 -5.82277680e-04 1.72123613e-02
-1.34775678e-03 6.04916107e-02 -3.42018555e-04 -1.53786891e-02 1.00000063e+00 -5.87656797e-02
4.16565684e-04 4.71329578e-03 7.72132307e-04 2.51667933e-04 -4.60194682e-04 1.00028640e+00
#Matrix X1Inv * X2 (transposed)
-1.21131193e-06 -2.84396123e-05 3.50821687e-05 9.53042867e-07 9.15295541e-06 -5.29259429e-08
-4.38116340e-05 3.01665139e-05 -2.36894420e-05 6.05965777e-06 5.62276857e-05 8.83251847e-06
8.55060428e-06 3.55549865e-06 -2.70876190e-06 1.61423455e-06 3.22220385e-06 2.71587989e-08
-1.59285317e-05 1.02587330e-05 -1.25808935e-05 -3.84263816e-07 9.39303269e-06 -1.94344906e-06
6.50276231e-06 5.87791604e-07 -5.36129746e-07 4.58410682e-07 4.00497366e-06 1.01373067e-08
-1.03117215e-05 1.89925143e-05 -1.57112317e-05 5.40837250e-06 -7.18690298e-05 9.73144458e-07
-9.21557083e-07 2.67539123e-06 -2.17341417e-06 -1.77195531e-06 1.00906718e-05 -2.52359097e-06
2.70575526e-06 5.40984758e-07 -6.53920269e-06 5.45164023e-07 4.02989560e-06 -3.73246305e-06
-3.31089810e-06 -1.18114368e-06 9.62492845e-07 1.58401047e-05 -2.22377123e-05 4.02665711e-07
6.76992583e-06 -9.86788953e-07 7.73190547e-07 4.20264787e-06 -8.82983362e-06 1.13016865e-07
1.22950149e-06 -1.93158354e-05 5.19148339e-05 -3.63370955e-07 1.04399962e-05 1.80072314e-05
1.81724667e-06 -1.17674466e-07 1.60560272e-06 -1.07101404e-05 4.64640962e-05 5.24175304e-06
-6.96724490e-06 -5.17390433e-06 2.20420896e-05 -3.42940957e-06 -1.45811596e-05 5.11370514e-05
-4.25291398e-07 1.98834007e-07 -6.20033984e-05 -1.43960086e-06 5.74603141e-06 -7.95631532e-06
-3.76082061e-05 8.00987698e-06 -1.22588606e-05 -4.04077783e-05 9.39990430e-05 -4.37041635e-06
1.43684375e-06 5.43727337e-06 6.07736449e-06 1.68152692e-07 1.85357847e-05 1.34179728e-06
-3.57804496e-08 2.51240275e-06 -1.17964614e-06 -2.33015884e-07 -1.06757295e-06 -2.57732940e-07
-2.81046268e-05 -4.01420734e-06 2.65065740e-06 -1.47746926e-06 -4.48368074e-06 4.35094842e-06
2.28781446e-05 4.07285478e-07 -1.99918564e-06 2.75094665e-06 -7.96708766e-06 -3.60298801e-07
3.73853128e-06 -7.06116128e-06 3.95191656e-06 2.29832925e-07 3.11259011e-06 -4.49478837e-06
-1.12130584e-06 -3.82602606e-06 -6.27838682e-06 3.40710143e-07 -9.97432645e-06 -7.30593387e-07
#Balance deflection matrix [k]
0.0000000 0.0000000 0.0000000 0.0000000 0.0000000
#Balance safe loads
250.0 250.0 350.0 200.0 700.0 100.0
#Tare weight matrix
twt001.out
126.6324 -1.0284 24.2873 62.5491 22.4292 22.9390 135.3243 51.4012 0.2813
#Miscellaneous
% sampling, nsamples, wtcorr_req
1 10 1
#Output File Format
velocity
alpha
beta
tail ang
act ang
RPS
wind axes
body axes

```

DISTRIBUTION LIST

WTSETUP: Software for Creating and Editing Configuration Files in the Low Speed
Wind Tunnel Data Acquisition System

Craig D. Edwards

AUSTRALIA

DEFENCE ORGANISATION

Task sponsor

S&T Program

Chief Defence Scientist
FAS Science Policy
AS Science Corporate Management
Director General Science Policy Development
Counsellor Defence Science, London (Doc Data Sheet)
Counsellor Defence Science, Washington (Doc Data Sheet)
Scientific Adviser to MRDC Thailand (Doc Data Sheet)
Scientific Adviser Policy and Command
Navy Scientific Adviser (Doc Data Sheet and distribution list only)
Scientific Adviser - Army (Doc Data Sheet and distribution list only)
Air Force Scientific Adviser
Director Trials

} shared copy

Aeronautical and Maritime Research Laboratory

Director

Chief of Air Operations Division

Neil Pollock

D. Glenny

S. Oldfield

Neil Matheson (2 copies)

B. Fairlie

Author: Craig Edwards (2 copies)

Y. Link (3 copies)

S. Lam H. Quick

R. Toffoletto S. Leung

L. Erm G. Ainger

M. Glaister D. Carnell

J. Clayton P. Malone

I. Amott A. Gonzales

J. Harvey F. Bird

R. Worl S. Kent

M. Spataro O. Holland

DSTO Library

Library Fishermens Bend

Library Maribyrnong

Library Salisbury (2 copies)

Australian Archives

Library, MOD, Pyrmont (Doc Data sheet only)

*US Defence Technical Information Center, 2 copies

*UK Defence Research Information Centre, 2 copies

*Canada Defence Scientific Information Service, 1 copy

*NZ Defence Information Centre, 1 copy

National Library of Australia, 1 copy

Capability Development Division

Director General Maritime Development (Doc Data Sheet only)

Director General Land Development (Doc Data Sheet only)

Director General C3I Development (Doc Data Sheet only)

Director General Aerospace Development (Doc Data Sheet only)

Army

ABCA Standardisation Officer, Puckapunyal, (4 copies)

SO (Science), DJFHQ(L), MILPO Enoggera, Queensland 4051 (Doc Data Sheet only)

NAPOC QWG Engineer NBCD c/- DENGRS-A, HQ Engineer Centre Liverpool
Military Area, NSW 2174 (Doc Data Sheet only)

Intelligence Program

DGSTA Defence Intelligence Organisation

Corporate Support Program

OIC TRS, Defence Regional Library, Canberra

UNIVERSITIES AND COLLEGES

Australian Defence Force Academy

Library

Head of Aerospace and Mechanical Engineering

Senior Librarian, Hargrave Library, Monash University

Librarian, Flinders University

OTHER ORGANISATIONS

NASA (Canberra)

AGPS

OUTSIDE AUSTRALIA

ABSTRACTING AND INFORMATION ORGANISATIONS

Library, Chemical Abstracts Reference Service

Engineering Societies Library, US

Materials Information, Cambridge Scientific Abstracts, US

Documents Librarian, The Center for Research Libraries, US

INFORMATION EXCHANGE AGREEMENT PARTNERS

Acquisitions Unit, Science Reference and Information Service, UK

Library - Exchange Desk, National Institute of Standards and Technology, US

SPARES (5 copies)

Total number of copies: 72

DEFENCE SCIENCE AND TECHNOLOGY ORGANISATION DOCUMENT CONTROL DATA				1. PRIVACY MARKING/CAVEAT (OF DOCUMENT)	
2. TITLE WTSETUP: Software for Creating and Editing Configuration Files in the Low Speed Wind Tunnel Data Acquisition System			3. SECURITY CLASSIFICATION (FOR UNCLASSIFIED REPORTS THAT ARE LIMITED RELEASE USE (L) NEXT TO DOCUMENT CLASSIFICATION) Document (U) Title (U) Abstract (U)		
4. AUTHOR(S) Craig D. Edwards			5. CORPORATE AUTHOR Aeronautical and Maritime Research Laboratory PO Box 4331 Melbourne Vic 3001 Australia		
6a. DSTO NUMBER DSTO-TN-0217		6b. AR NUMBER AR-011-055		6c. TYPE OF REPORT Technical Note	7. DOCUMENT DATE August 1999
8. FILE NUMBER M1/9/614		9. TASK NUMBER 98/179	10. TASK SPONSOR DST	11. NO. OF PAGES 26	12. NO. OF REFERENCES 5
13. DOWNGRADING/DELIMITING INSTRUCTIONS				14. RELEASE AUTHORITY Chief, Air Operations Division	
15. SECONDARY RELEASE STATEMENT OF THIS DOCUMENT <i>Approved for public release</i>					
OVERSEAS ENQUIRIES OUTSIDE STATED LIMITATIONS SHOULD BE REFERRED THROUGH DOCUMENT EXCHANGE, PO BOX 1500, SALISBURY, SA 5108					
16. DELIBERATE ANNOUNCEMENT No Limitations					
17. CASUAL ANNOUNCEMENT Yes					
18. DEFTEST DESCRIPTORS Computer systems; Data acquisition; Systems; Software; Wind tunnels					
19. ABSTRACT The Data Acquisition System in the Low Speed Wind Tunnel is responsible for the measurement, recording processing and displaying of wind tunnel test data. The system requires a number of initialisation files which define the test programme, model configuration, hardware setup and data reduction processes. Software titled WTSETUP has been developed which allows the operator to create and/or edit these configuration files via a user friendly, windows-based interface. This document enables a typical wind tunnel user to become familiar with the software and its operation and it defines the configuration file parameters commonly used in wind tunnel testing at the Aeronautical and Maritime Research Laboratory.					