

DISTRIBUTION STATEMENT A
Approved for Public Release
Distribution Unlimited

43rd Annual

Fuze Conference

Fuzing Challenges;

Opportunities to Excel

Munitions Technology

Symposium VI

hosted by Munitions Manufacturing

and Technology Section

19991021 057

Downtown Tampa, FL

April 6-8, 1999

Meeting #957

DTIC QUALITY INSPECTED 4

**43rd Annual Fuze Conference and Munitions Technology
Symposium VI**

6-8 April 1999

Table of Contents

Wednesday, April 7, 1999

"Keynote Address," by Dr. Peter A. Bukowick, President & COO, Alliant Techsystems, Inc _____	1
"Keynote Slide Presentation," by Dr. Peter A. Bukowick, President & COO, Alliant Techsystems. _____	16
"A Viewpoint from OSD," by Mr. Anthony J. Melita, Deputy Director, Strategic & Tactical Systems Munitions, Office of the Secretary of Defense. _____	21
"Armament/Ammunition Developments at AACOM-ARDEC: Future Challenges and Opportunities in Fuzing," by BG John P. Geis, Commanding General, U.S. Army Tank-Automotive and Armaments Command (TACOM), Armament Research, Development and Engineering Center (ARDEC). _____	44
"HTI Fuzes in Tactical Missiles," by COL Barry M. Ward, Project Manager, Multiple Launch Rocket System. _____	65
"Future Fires," by COL Peter S. Corpac, Director, Depth and Simultaneous Attack Battle Lab, U.S. Army Field Artillery School (USAFAS). _____	83
"Crusader: Army 21 Firepower Revolution," by MAJ Stephen E. Hitz, Office of the TRADOC System Manager Cannon, USAFAS. _____	96
"Fuzing for Direct Combat Applications," by COL Raymond Pawlicki, Project Manager (PM), Tank Main Armament Systems. _____	113

"Fuzing for Landmine Alternatives," by COL Thomas E. Dresen, PM, Mines, Countermine and Demolitions. _____	144
"Ammunition Program Update," by BG John J. Deyermond, Deputy Chief of Staff for Ammunition, U.S. Army Materiel Command. _____	161
"Dahlgren Overview," by Michael Till, Naval Surface Warfare Center (NSWC, Dahlgren). _____	185
"Indian Head Overview," by CAPT John Walsh, USN Commander, Indian Head Division, NSWC. _____	209
"Innovations in Proximity Fuzing," by David Lawson, KDI Precision Products; Mr. Telly Manolatos, Electronic Development Corp. and Ron Wardell, TACOM-ARDEC. _____	218
"Processing Energetic Material at Thiokol's 19mm Twin Screw Extrusion Facility," by Mr. Andrew Haaland, Thiokol Propulsion Group. _____	234
"Highly Integrated," by Mr. Tom Nickolin, KDI Precision products, Inc.; Mr. George Hennings, NAWC, China Lake; Mr. John Cole, Silicon Designs, Inc. and Tom Reynolds, Reynolds Systems, Inc. _____	258
Thursday, April 8, 1999	
"Fuzing for Special Environments," by Mr. James Sorenson, PRIMEX Technologies; Mr. Markus Joost, EMS-Patvag and Mr. Ruedi Zaugg, Zaugg elektronik, AG. _____	289
"Thin Film Detonator Technology for Special Environments," by Mr. Markus Joost, EMS-Patvag; Mr. James Sorensen and Mr. Flavio Zanatta, PRIMEX Technologies. _____	310
"Safe Separation for SABRE, a Non-Traditional Weapon/Shallow-Water Sensing Mechanical Fuze," by Mr. Keith B. Lewis and Mr. Matthew J. Sanford, NSWC Dahlgren Division. _____	326
"Miniature Electronic Safing and Arming Device," by Mr. Victor C. Rimkus, SNL. _____	340

"THAMES 3.0: The Window to Threat Hazard
Assessment," by Mr. Jason de W. FitzGerald
and Mr. Gernt Mannessan, NATO Insensitive
Munitions Information on Centre NATO HQ, Brussels. _____ 359

Design and Qualification Results for the
Firing Module for the Common Module ESAF (C-ESAF) _____ 372

43rd Annual Fuze Conference
Dr. Peter A. Bukowick
Keynote Speech
April 7, 1999

Fuze Reliability

Slide 1: Title slide

Thank you, Len. It is a pleasure and an honor to be speaking to the fuze conference today. Fuzing is one of the core technologies where I work; more importantly, fuze reliability is critical to our military capability.

My purpose here today is to offer some thoughts on a common interest we all share as users of fuze, developers, and manufacturers; namely, fuze reliability. Reliability provides the soldiers, sailors, and airmen who depend on our work with fuzes that enable them to accomplish the mission.

The mission of a fuze can be described in simple terms, yet this belies the complexity required to accomplish seemingly contradictory tasks, namely:

Slide 2: Mission

- The fuze must be safe for the user—that is, safe to manufacture, store, handle, and deliver.

- At the same time, it must be lethal to the enemy.

Our common goal as members of the fuze community is to provide systems that accomplish this double mission—100 percent of the time. It is safe to say we have not yet achieved this goal. Before we look forward to 100 percent reliability, let's look backward to where we have been.

In 1856, Commander Dahlgren made the observation that without a good system of fuzes, artillery projectiles would be "bodies without souls." I would agree with that observation to a point, but would rephrase it as "bodies without minds." The commander was referring to the technological evolution from solid projectiles to bursting shot and shells. Just as it is today, precise timing was essential then. With case shot traveling 1200 feet per second, a quarter of a second timing error would result in a burst point error of 100 yards. (Ideally, these rounds were to burst 50 yards in front of the enemy.)

In fact, the essence of the fuze, the real purpose for a fuze, lies in the need for weapons to "think," to take autonomous action once they have been released by their users. The fuze must know whether it is still in friendly hands or being delivered to enemy hands.

The advance of other aspects of military technology has been matched by the evolution and refinement of the fuze. The ability to project weapons to greater distances, and thus greater standoff from "harm's way," means the projectiles or weapons need to function autonomously well after they have been released. A certain complexity in the warhead is also implied.

Slide 3: Spanish 16" Pedrero (1788) "Basket of Stones"

Rocks, sticks, clubs, arrows, and other kinetic energy rounds do not need fuzes. The stone mortar, vintage late 18th century, was one such delivery system for kinetic energy projectiles. Round stones, roughly the size of a man's fist, were loaded into a basket and lowered into the bore of the stone mortar. The primitive charge was fired into the air against a defensive position at close range. The stones would descend on the enemy; brainless projectiles, no fuzes.

The American Civil War marked a transition from traditional weaponry to many modern, more intelligent weaponry concepts. Some people have referred to the American Civil War as the first modern war because of innovations such as the submarine, machine gun, military rocket, and a proliferation of fuzed projectiles. So many variations of guns, projectiles, and fuzes existed that the military leaders and logisticians of both sides

lamented the confusion. They called for a reduction of the number of variants and the standardization of fuze setting procedures. If this sounds familiar, it is. We are currently struggling with the same issues of fuze commonality across weapon types and NATO standardization for setting of all types of fuzes.

Slide 4: Wooden powder fuze and time gradation + table of fire

The first projectile time fuzes consisted of tapered cylinders of wood, hollowed out and packed with a composition of gunpowder moistened with whiskey or alcohol. When dry, the rate of burning would be determined by experiment and marked on the fuzes in the lot.

The gunner, after learning the range to the target, determined the elevation and flight time from a table similar to the one shown. A certain amount of mathematical skill was expected in order to interpolate from the ranges given in the table. The fuze, marked in tenths of inches, was set by cutting it to the proper length with a fuze saw: the first fuze setter. You can tell this soldier is new to the job: he still has both hands. As you know, accuracy and repeatability are absolutely essential to the effectiveness of time fuzed weapons. This process did not have it. The burn rate of the composition packed into the wooden tubes was variable. The packing resulted in uneven

stratification of the powder. The brand and proof of the whiskey used in the process may also have affected the outcome.

Slide 5: Paper fuzes, including papers

To resolve this problem and improve fuze repeatability, North and South both upgraded this primitive approach by developing the paper fuze. Paper fuzes were factory made and color-coded: yellow burned five seconds to the inch, green seven, and blue ten. The Union ordnance department decreed that only the Frankford Arsenal could manufacture paper fuzes. This was done to ensure a consistent controlled process, with uniform material to ensure a repeatable product.

The Confederate ordnance bureau could not afford this luxury, and the variability of their fuzes, in comparison to those of their Union counterparts, was a regular source of frustration to the Confederate artillery. Whether with wooden or paper fuzes, however, the job of the Civil War artilleryman was dangerous. Both wooden composition and paper fuzes continued to suffer from the shocks of the field environment, which tended to break up the solid composition, allowing fire to penetrate too quickly to the main charge, with disastrous, gun exploding consequences.

Slide 6: Federal and Confederate Bormann time fuze and shells with fuzes installed

The next advance in the time fuze was named after its inventor, Belgian Army Captain Charles G. Bormann. The Bormann time fuze was a Belgian state secret for many years, until it was leaked in the 1850s.

This fuze, like the paper and wood fuzes, was placed into a hole in the cannonball. The hollow inside the cannonball was filled with explosives. The cannonball had to be correctly loaded into the gun barrel—fuze to the front. If the cannonball was not correctly oriented, the fuze would initiate prematurely. The Bormann fuze was also a pyrotechnic delay fuze, but the burn consistency was much more repeatable, given proper process control. As an added benefit, the setting process was quicker. To set the fuze, the gunnery crew would punch a hole in the soft pewter face of the fuze. The number indicated the time required to burst. Setter technology had evolved from the fuze saw to the hole punch. The powder inside the fuze was ignited through the hole by the propellant flame as it swept around the projectile.

The Bormann fuze became the Union standard for spherical case shot but ended up being a nightmare for the Confederacy. After large quantities of their ammunition had been fuzed with the Bormann fuze, field reports

indicated that fully four-fifths of the Confederate Bormann fuze shells exploded prematurely, and very many of them in the gun. A lengthy investigation found the trouble to be in the sealing of the horseshoe channel containing the composition. The shock of discharge would unseat the horseshoe shaped plug that protected this channel and allow the flame from the propellant to bypass the composition, reaching the charge of the shell prematurely. As the result of infantry casualties from their own guns during the Battle of Fredericksburg, the Confederacy decided to abandon the Bormann fuze. Artillery reverted to the older, but easier to manufacture, paper fuze.

As the Civil War progressed, the use of rifled guns became more prevalent due to their increased accuracy and range. The projectiles for these new guns evolved from spherical case shot to the more familiar cylindrical shells we have today. This projectile shape meant the impact point of the shell could be better predicted, compared to spherical shells or cannonballs. This fact lead to a new type of fuze called the percussion fuze, or as we would call it today, the impact fuze. These fuzes were sometimes combined with time fuzing pyrotechnic delays, and thus the combination fuze was born. This fuze could be set for time or impact, with each function usable separately or in combination.

Slide 7: Armstrong E fuze

Dozens of these fuzes proliferated during the conflict, but the most successful design was the Armstrong "E" Fuze, so named because it took five revisions to get it right, and "E" is the fifth letter of the alphabet. The Armstrong E fuze was fairly reliable and remained in British Army service until the 1890s.

The advent of World War One generated another flurry of technological advances. Gone were the old spherical case shot rounds. Safety became a much more achievable and required function.

Slide 8: Mark V point detonating fuze

A good example of this design for safety is provided by the Mark Five point detonating fuze used in the seventy-five millimeter guns of the day. This design was adapted from the French, with the American addition of the interrupter for extra safety. While the shell using this fuze was being accelerated in the gun bore, the interrupter would remain in the safe position, blocking the explosive train from premature function and making the round bore safe. Once outside the muzzle, the interrupter withdrew—as acceleration ceased—to allow the explosive train to propagate.

Fuze technology continued to progress from strictly pyrotechnic timing to mechanical "clockwork" timing, and eventually encompassed proximity fuzing. The proximity fuze becomes possible when you can instill enough intelligence in the fuze to establish its burst point not in reference to "where it has been," but rather in reference to "where it is going." The explosion of electronic technology in the mid and late twentieth century has enabled us to continuously expand the autonomous decision-making capability of the fuze.

Slide 9: Variable Time (VT) fuze

The first radio frequency artillery fuze was developed during World War Two. William T. Moye, historian for the U.S. Army Research Laboratory, has said, "Its development ranks with the maturation of radar and the atomic bomb as the major scientific achievements which contributed to the allied victory."

The variable time, or VT fuze (so named to conceal its true proximity function), was developed by Division Four of the National Defence Research Committee (the NDRC) under the leadership of Dr. Alexander H. Ellet and Harry Diamond. The major challenge was to develop sensors that could withstand the high-g forces of gun launch. There were smaller challenges, too. Wax often disappeared from the fuzes because the soldiers

found that it made good chewing gum. The VT fuze marked the beginning of the modern era of electronic fuzing, and its production in the mid 1940s occupied much of the U.S. industrial capacity in both electronics and plastics. Its impact on the enemy was devastating, even though it was fielded late in the war. General Patton wrote "...the new shell with the funny fuze is devastating.... I think that when all armies get this shell we will have to devise some new method of warfare. I am glad that you all thought of it first."

Slide 10: Family of current fuzes

The VT was the forefather to the current family of high performance projectile fuzes. Interestingly enough, today we work to standardize to a small compatible family of fuzes, just as our Civil War predecessors did 140 years ago. The assortment of point detonating, time, and proximity fuzes has found a hybrid offspring in the Multi-Option Fuze for Artillery, or MOFA. The M762 is today's primary time fuze; and the Mark 399 is the standard fuze for military operations in urban terrain.

Throughout this brief survey of fuze history I have concentrated on cannon projectile fuzing because of its long and well documented technology. The technological growth of fuzes, however, has impacted almost all devices

utilizing a warhead—from submunitions and hand emplaced weapons to bombs and missiles. The impact of fuze effectiveness, including safety, reliability, and repeatability, has been crucial to our warfighters in the past. It will be even more so in the future. When I began, I mentioned the objective of delivering exceptional reliability in our fuzes. What progress has been made in the last century and a half? Although data is sparse as we move further into the past along the fuze timeline, there are some known facts.

Slide 11: Comparative fuze table

During the siege of Petersburg, fuze reliability data was kept for various Union fuzes over a nine-month period during 1864 and 1865. The range in reliability is surprising, with the best fuzes performing at 85 percent and the worst at 53 percent. We have improved, as can be seen from more recent reliability data taken from a mechanical time fuze and a more modern electronic time fuze. We now need to look forward and establish our goals for the future as we strive for continuous improvement in quality, in repeatability, in reliability.

Slide 12: Fuze quality path

To achieve these goals, we can use the Fuze Quality Path, a derivation of Quality Functional Deployment, or QFD. It is a sequence of four matrices or phases, each essential to final fuze performance. I'll briefly describe each phase.

The first phase is an early and clear understanding of fuze requirements. We have made good progress in our working together as Integrated Product Teams, or IPTs. We need to continue this, starting it even earlier in the process, ensuring that the user's need is clearly met, documented, and communicated to the developer and producer.

With a clear requirement in mind, our next challenge—phase two—is to ensure that this requirement is met, with margin. In effect, QFD allows us to perform a sensitivity study on our fuzing system. This in turn identifies and prioritizes the key parameters that must be carefully tested and monitored during the development process to ensure that the design margin is inherent in the new fuze. This is the single biggest challenge to all of us in the fuze community today: identifying the correct system performance metrics early, adjusting them if required during Engineering and Manufacturing Development, and tracking them relentlessly throughout the whole process.

Phase three translates the critical part characteristics into critical process parameters. We select the best processes for part manufacture and assembly and identify the parameters that we must control through production.

Analyzing the coefficients of variation and the process capability of the key steps in the process improves the repeatability of the fuze.

What we've learned in the first three steps can now be fed into phase four, production planning. This is where all of the previous lessons and results come together in a workable production package that can direct shop floor actions, so that we clearly understand and control what we must do to meet the customer's expectations and the warfighter's needs.

Slide 13: In-family Management

Statistical process control, or SPC, is key to achieving repeatability in our fuze products and processes. In-family management ensures that our processes and products are of consistent quality as opposed to simply being within specification. This means that only those products falling within the two sigma limits are automatically accepted. Products between two and three sigma are reviewed for acceptance, while those beyond three sigma we accept only on an exception basis. A step improvement in overall fuze

repeatability will be achieved when we all realize that for these key products, for our military, just being within specification is not good enough.

A third quality improvement tool for the future is Process Owner Reviews.

This simple yet powerful concept makes systematic the periodic review of the overall production process. All changes, no matter how insignificant, are analyzed and discussed before incorporation into fuze production. There is no such thing as a small change.

In-family management and process owner reviews help ensure repeatability.

They provide a basis for each of our respective organizations to build on, both separately and in cooperation. Our path to excellence can be summarized in three words: communication, cooperation, and control.

Communication in jointly defining, understanding, and documenting fuze requirements that meet the users' needs. Cooperation in working together on IPTs to ensure that the user's requirements are implemented in robust fuze designs. Control, in establishing and maintaining disciplined fuze manufacturing processes.

Commander Dahlgren complained in 1856 that "no advocate of any particular fuze could say more than 'it will fail in fewer cases than any other.'" No worse than the other guy. He was irritated by this attitude and I

don't blame him. We must all commit ourselves to continuous improvement.

We need to build on the accomplishments and lessons learned from our predecessors, and leave clear markers for our successors on the path to perfect quality.

Slide 14: MR never-makes-a-dud

With apologies to Gary Larson, I leave you with this thought. Mr. Never-Makes-a-Dud may know the secret to perfect quality, but he should share that knowledge to create a repeatable process for the industry.

I have great respect for the creative, intelligent, dedicated people in the fuze business, many of whom are at this conference. I know you are as determined as I am to deliver high performance, repeatable, reliable fuzes to our kids, whose lives rely on that reliability.

Thank you.

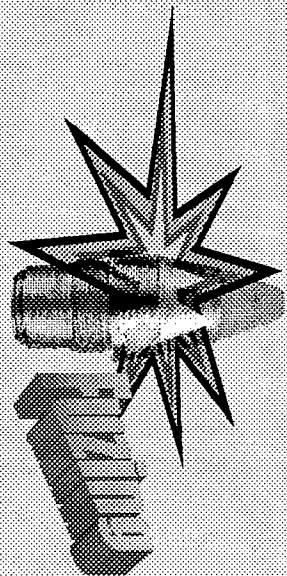

Fuze Reliability

**43rd Annual Fuze Conference
April 6-8, 1999**

Dr. Peter A. Bukowick
President and
Chief Operating Officer,
Alliant Techsystems

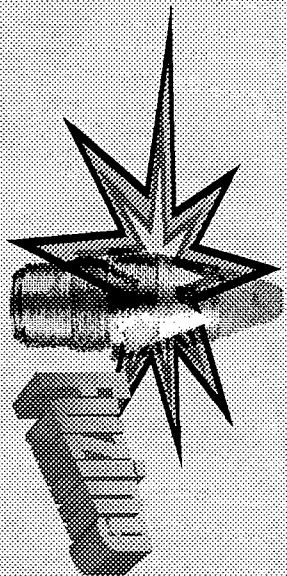

Mission

- **Be safe to manufacture, store, handle and deliver—safe to the user**
- **Be deadly once used—lethal to the enemy**

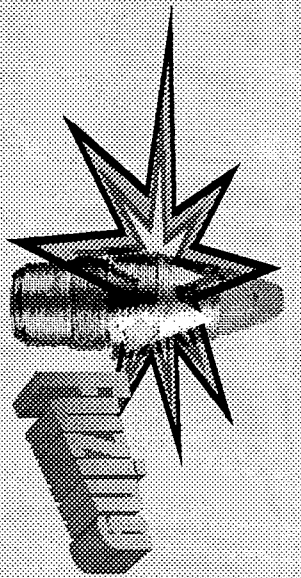

The Stone Mortar, 1788

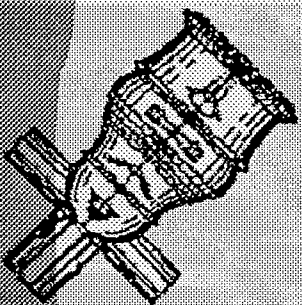
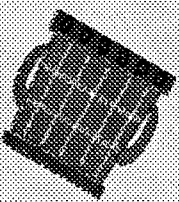
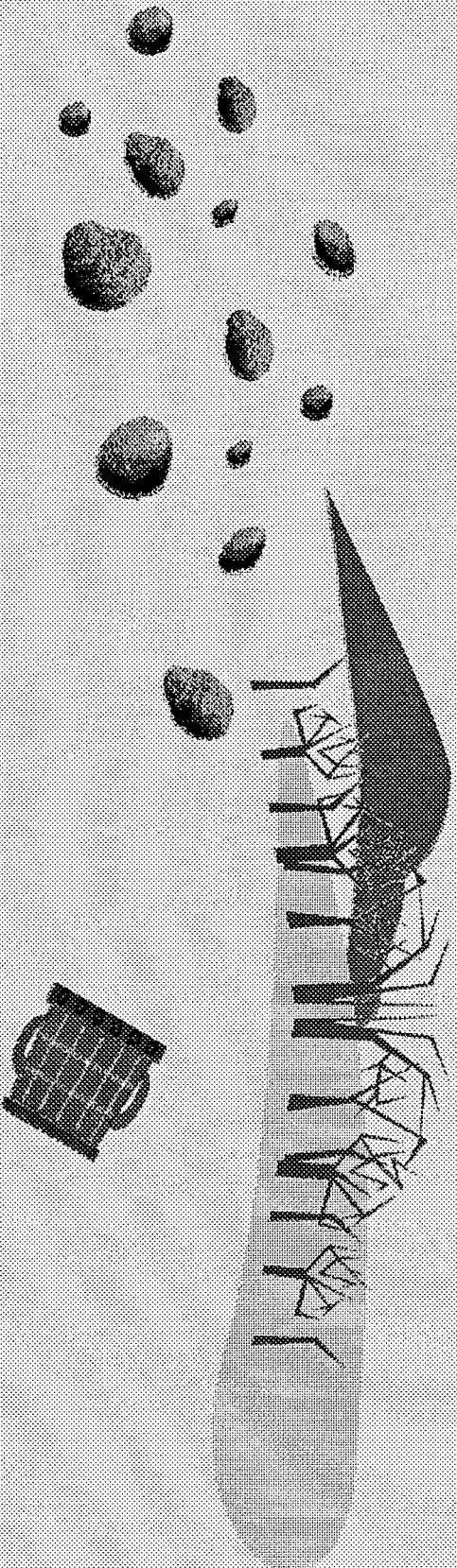

Kinetic energy projectiles don't need fuzes.

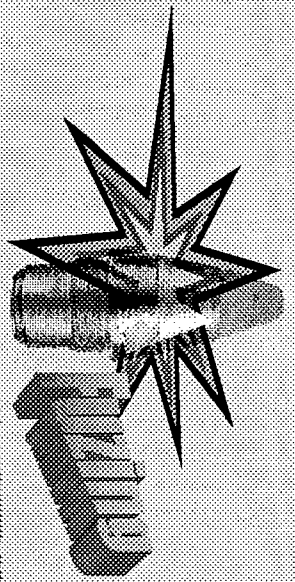

The Wooden Powder Fuze

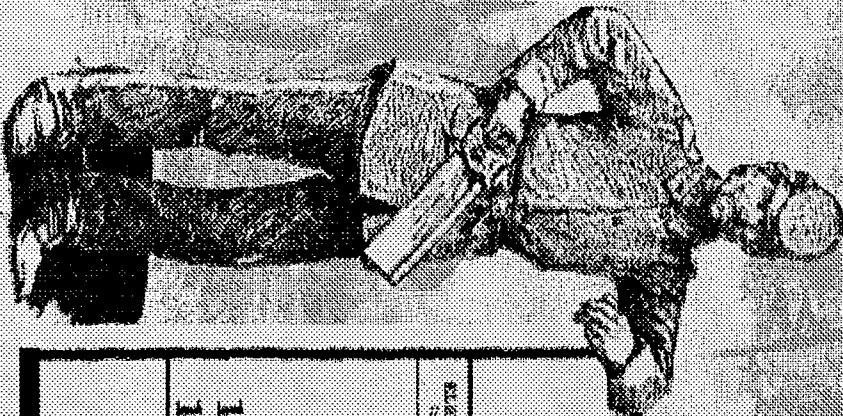
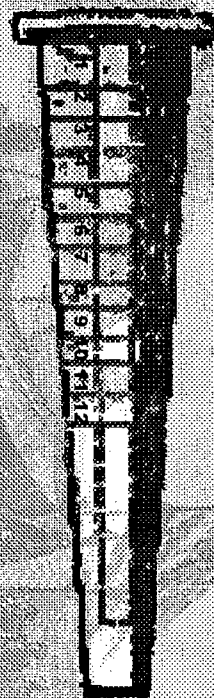

TABLE OF FIRE 20-PDR. PARROT GUN Charge, 2 lbs. of Mortar Powder

ELEVATION TO POINT	PROJECTILE	RANGE YARDS	TIME OF FLIGHT SECONDS
1	Case Shot, 19½ lbs.	620	17½
2	Case Shot, 19½ lbs.	950	3¼
3¾	Shell, 18¾ lbs.	1500	4¾
5	Shell, 18¾ lbs.	2100	6½
10	Shell, 18¾ lbs.	3350	11¼
15	Shell, 18¾ lbs.	4400	17¼

CARE OF AMMUNITION CASES

Do not unpack any shell from its box, or any case, until it is to be used. Keep all cases in a cool, dry place, and do not allow them to get wet. Do not use any case that has been damaged, or that is otherwise defective. Do not use any case that has been used for other purposes.

Published by the War Department, 1917.

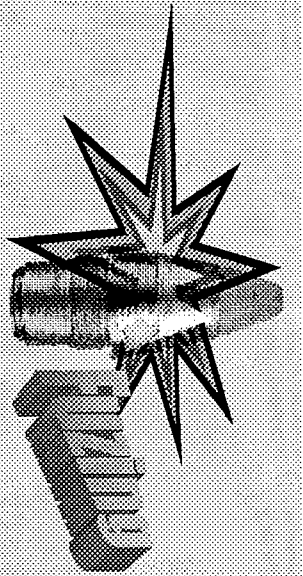

A Viewoint from OSD

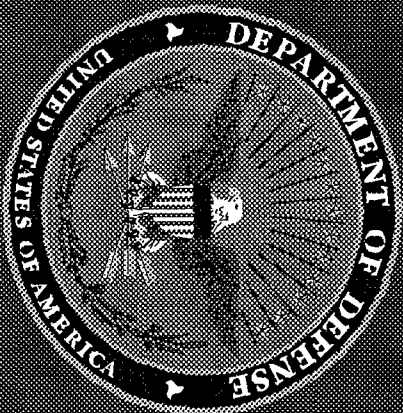

Anthony J. Melita
Deputy Director

Strategic and Tactical Systems, Munitions

OSD (A&T)/S&TS/OM
Room 3B1060
3090 Defense Pentagon
Washington, DC 20301-3090

(703) 695-1382
DSN 225-1382
Fax (703) 614-3496
E-Mail: melitaaj@acq.osd.mil

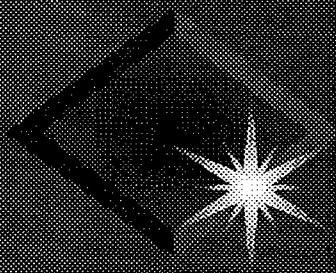

BRIEFING FLOW

- DoD Organization
- Office of Munitions
- Fiscal Trends
- Acquisition Reform

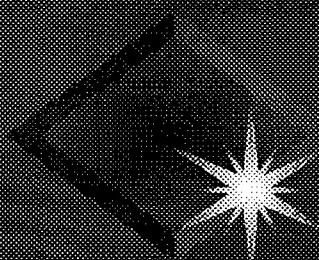

DOD ORGANIZATION

Secretary of Defense
Hon. William S. Cohen

Deputy Secretary of Defense
Hon. John J. Hamre

Under Secretary of Defense
(Acquisition and Technology)
Hon. Jacques S. Gansler
Principal Deputy
Hon. David R. Oliver, Jr.

Director, Defense Research and Engineering
Dr. Hans Mark

Director, Strategic & Tactical Systems
Dr. George Schneider

Deputy Dir., S&TS, Munitions
Mr. Anthony Melita

Secretary of the Army
Hon. Louis Caldera

Secretary of the Navy
Hon. Richard Danzig

Secretary of the Air Force
Hon. F. Whitten Peters, Acting



**OFFICE OF MUNITIONS (OM)
ORGANIZATIONAL SCOPE**

All
Conventional
Lethal and Non-Lethal Munitions
and Related Expendables
in
Research,
Development
and
Acquisition (RD&A)

(Excludes Nuclear, Biological, Chemical, and Special Access Munitions Programs)



OFFICE OF MUNITIONS FOCUS

- Ammunition Procurement/Reform
- Stockpile Management
- Insensitive Munitions
- Industrial Base
- Joint DoD/DOE Munitions Technology Program
- Conventional Munitions Master Plan (CMMP)
- NATO AC/310, Stockpile Planning, NIMIC
- Anti-Personnel Landmines
- Conventional Munitions Demilitarization
- Fuzing Technology
- Capabilities-Based Munitions Requirements (CBMR)



NATO INSENSITIVE MUNITIONS INFORMATION CENTRE (NIMIC)

- **A PROJECT OPERATING UNDER AN MOU AT NATO HQ, BRUSSELS**
 - **OBJECTIVES:**
 - ♦ **ACQUIRES WORLD KNOWLEDGE ON IM, STORING IT IN LINKED DATABASES UNIQUE TO NIMIC**
 - ♦ **DISSEMINATES INTERPRETED IM INFORMATION TO 10 NATIONS THAT PROVIDE FINANCIAL SUPPORT**
 - ♦ **IDENTIFIES DEFICIENCIES IN UNDERSTANDING IM TECHNOLOGIES AND INITAIATES PROCESS TO RECTIFY**
 - **ORGANIZATION: 9 FULL TIME TECHNICAL AND SUPPORT STAFF REPORT VIA THE PM TO A STEERING COMMITTEE CHAIRED BY A SENIOR DEFENCE FUNCTIONARY**
 - **OPERATION: SIMILAR TO AN ENGINEERING PROCESS**
 - **PAYOFF: ASSISTS WORKERS IN PARTICIPATING NATIONS SEEKING RESOLUTION TO IM AND MUNITION DESIGN SAFETY ISSUES VIA A NATIONAL FOCAL POINT OFFICER (NFPO)**
- U.S. NIMIC NFPO: Ms. Vicki Brady 760/939-7342**

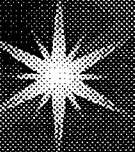

FISCAL TRENDS

Total Munitions RDT&E and Procurement

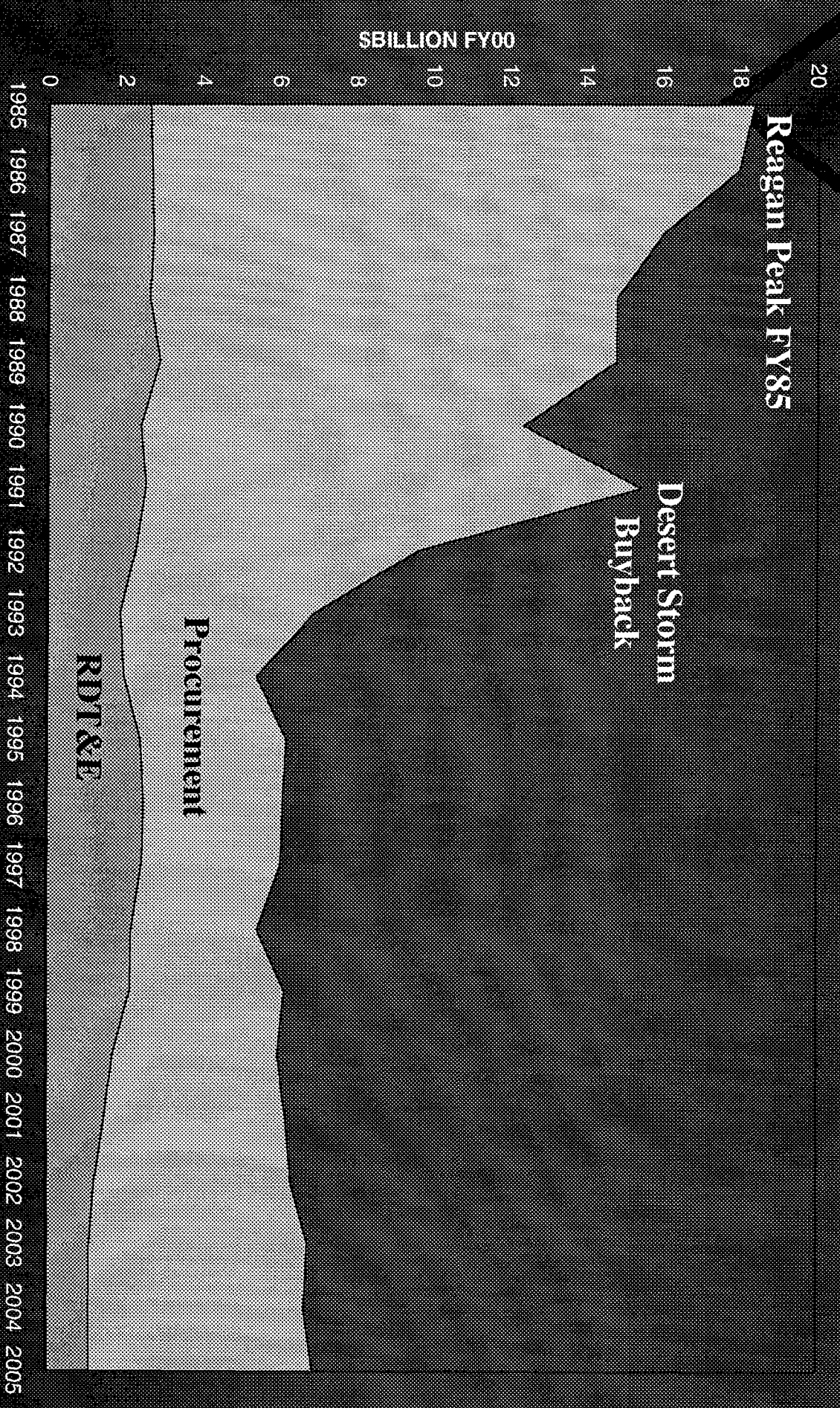

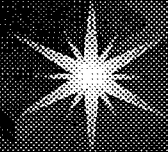

FISCAL TRENDS

Munitions Procurement

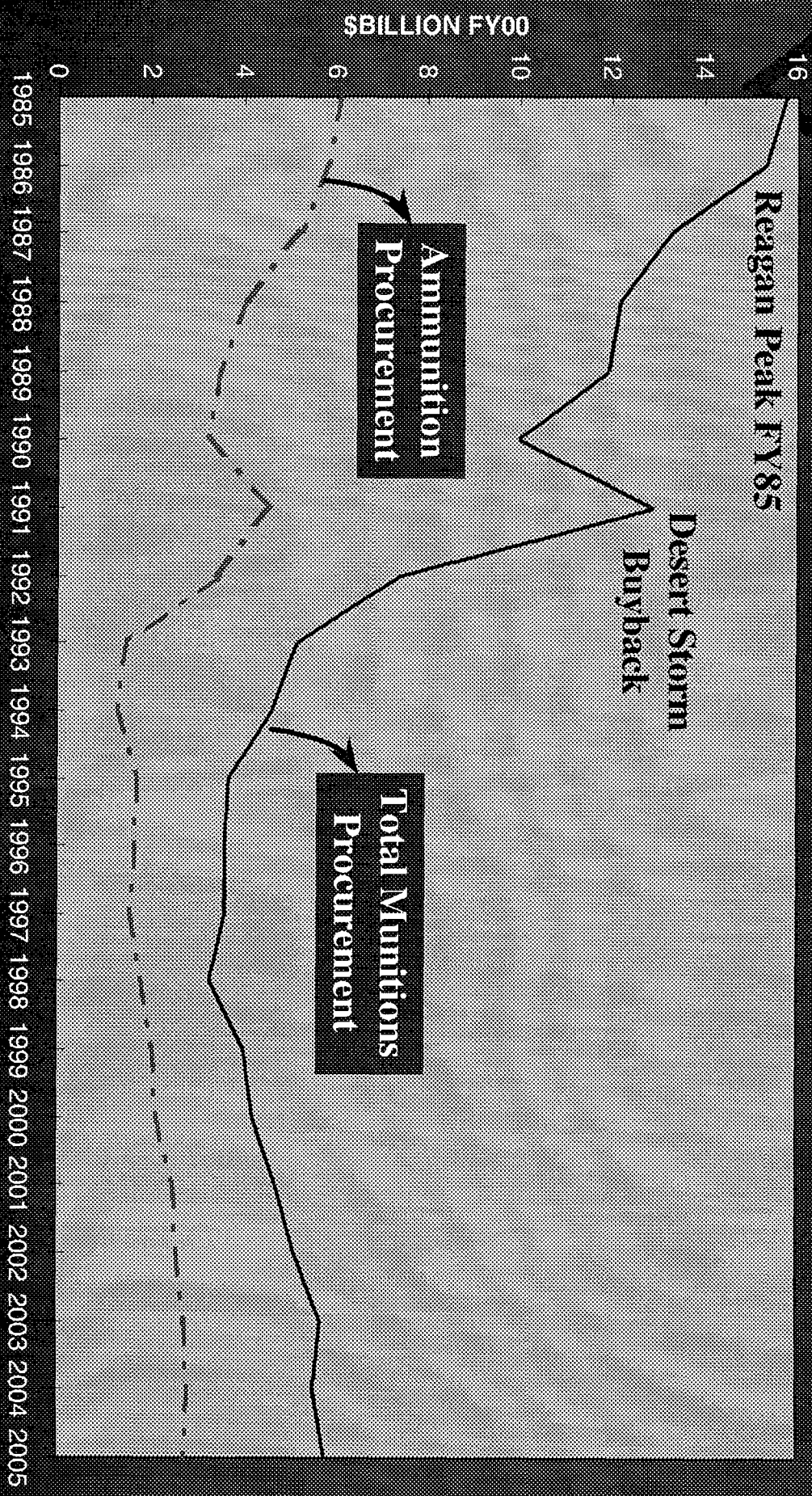

FISCAL TRENDS

Service Ammunition Procurement

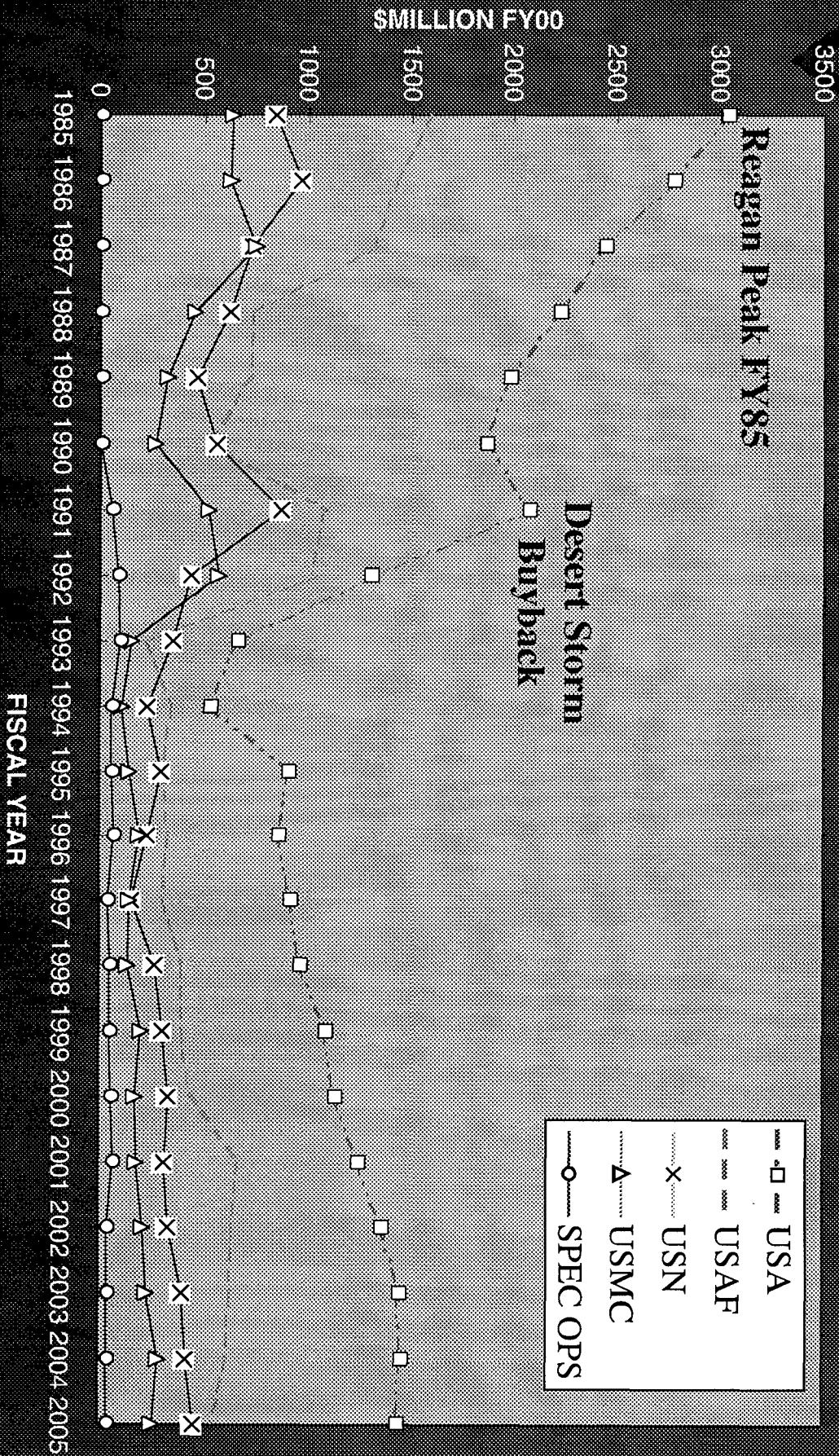

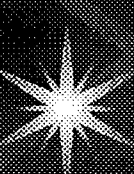

FISCAL TRENDS

Total Munitions and Fuze Procurement

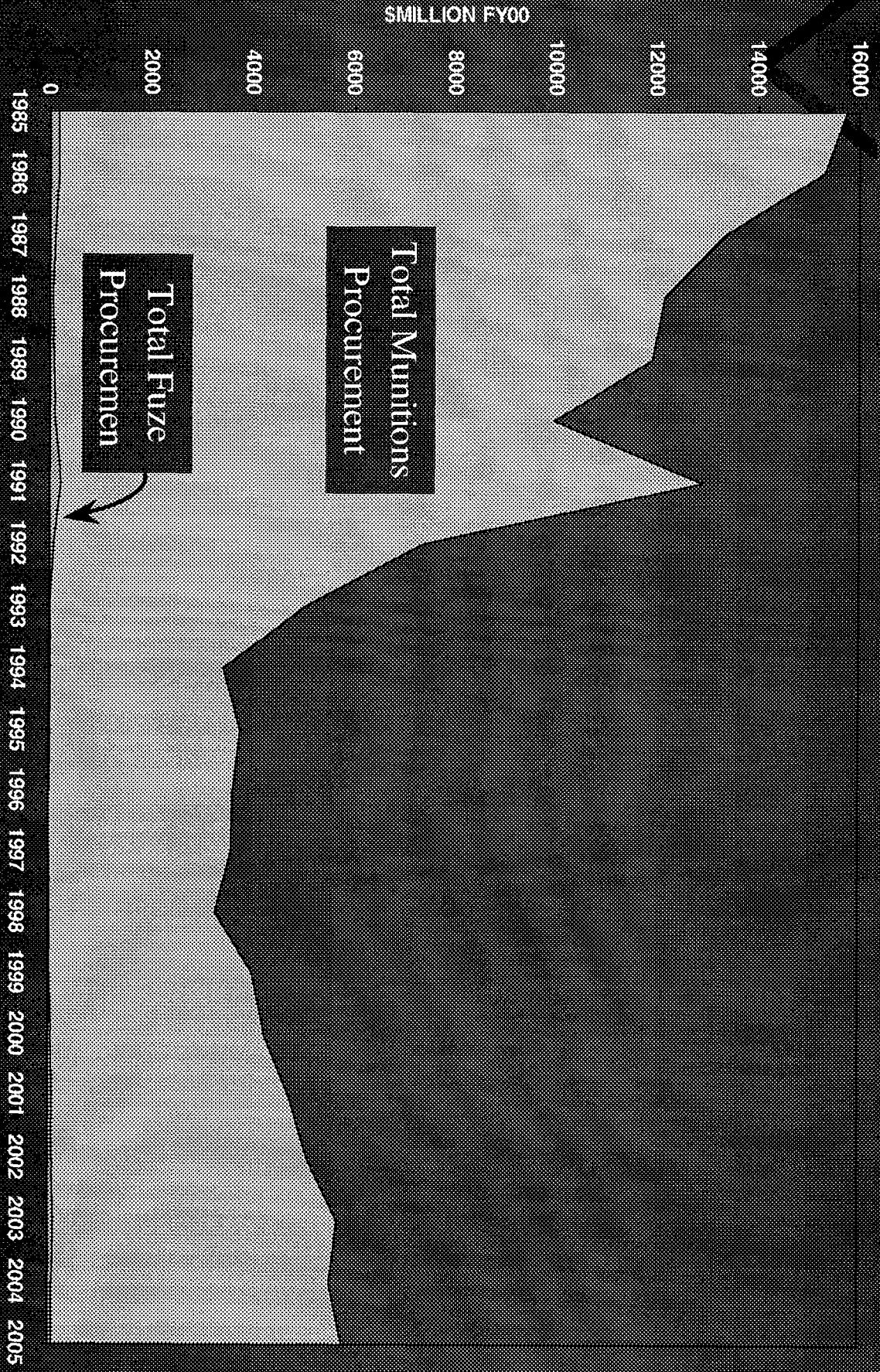

FISCAL TRENDS

Total Munitions and Fuze Procurement, Log Scale

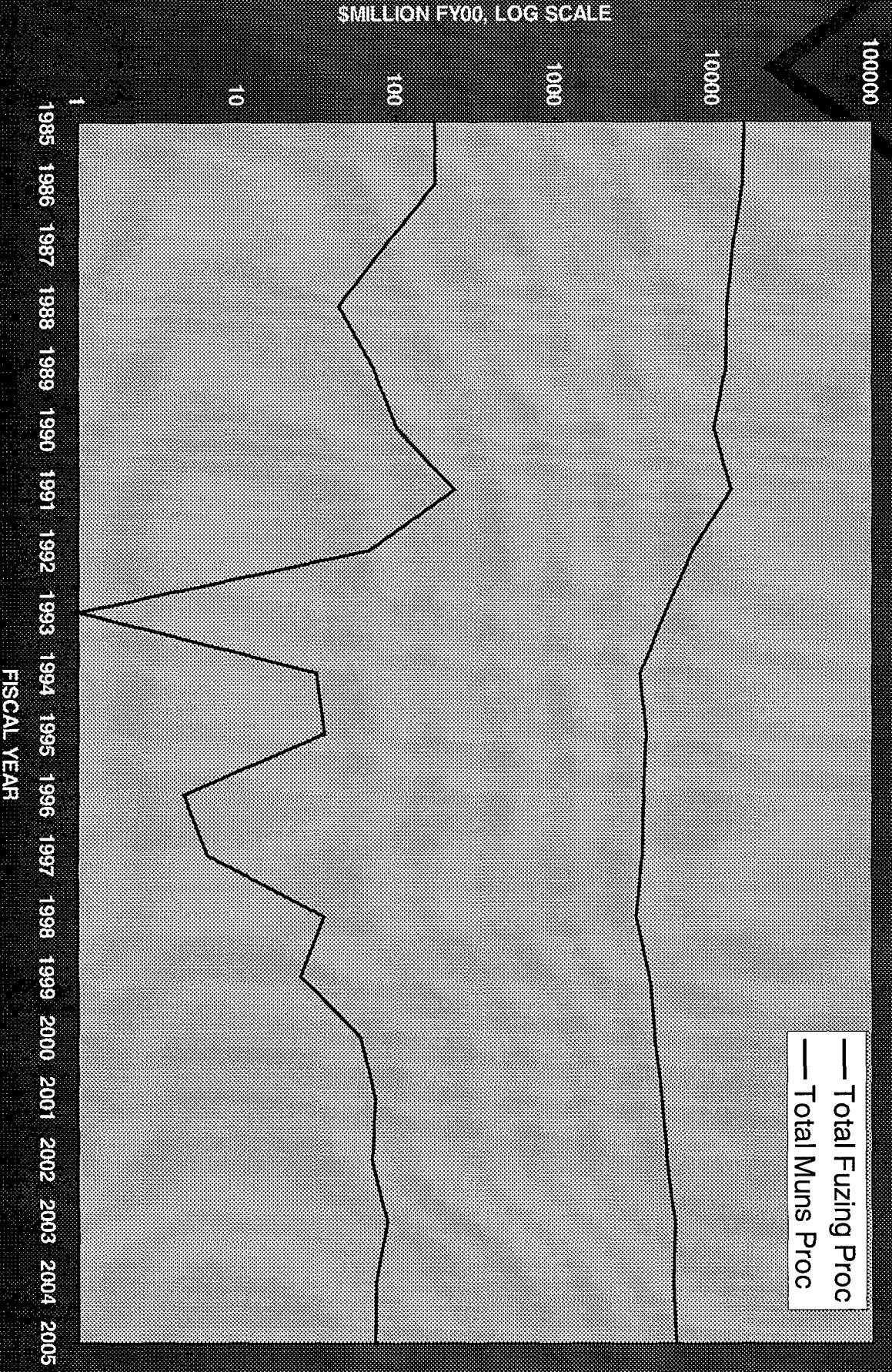

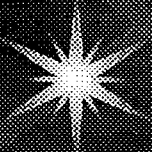

FISCAL TRENDS

Service Fuze Procurement

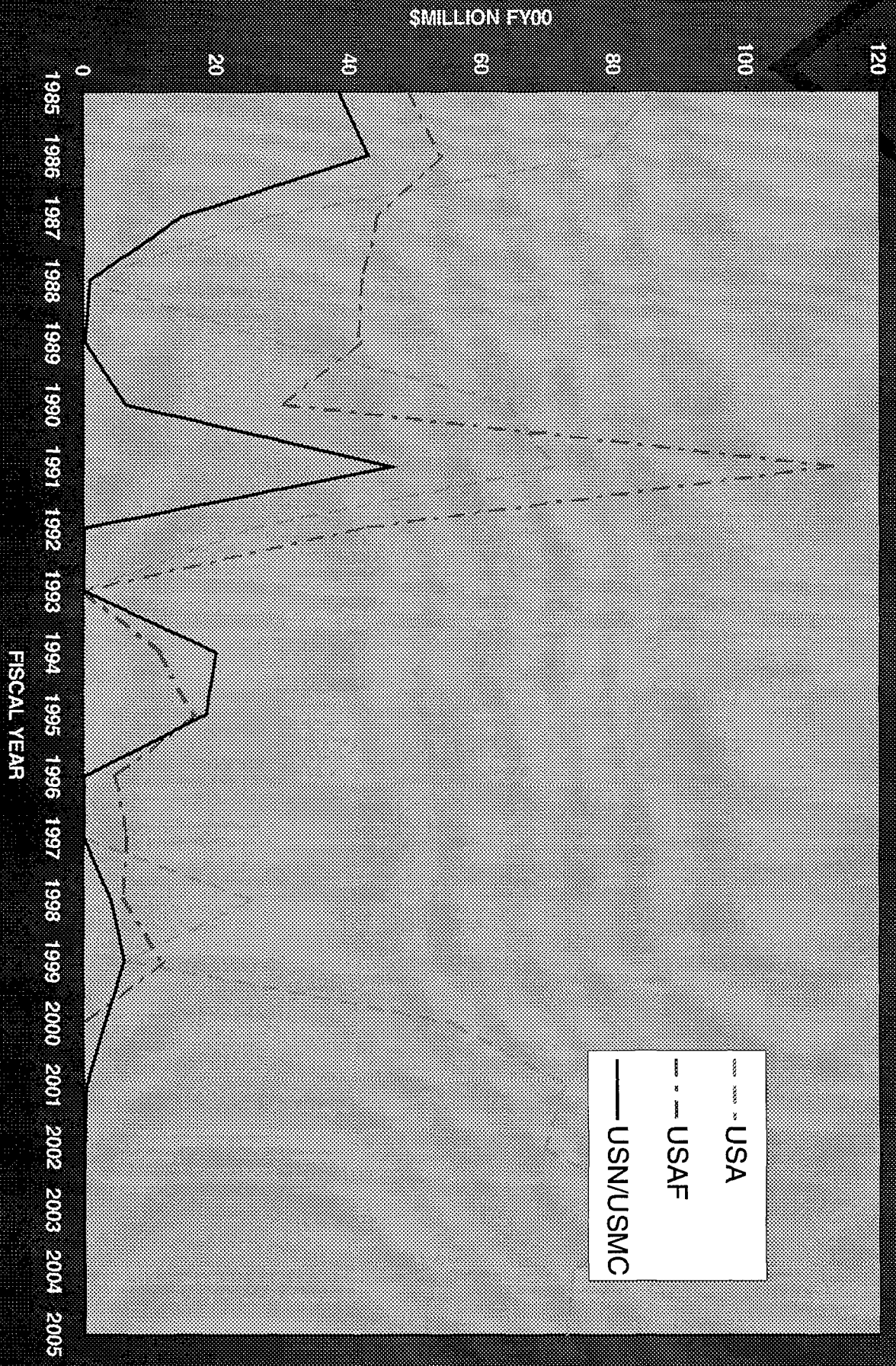

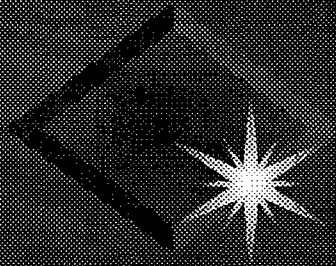

Acquisition Reform

Goals

- Allow suppliers to participate in IPTs.
- Strengthen & enforce the preference for commercial items.
- Provide for timely infusion of new technology.
- Eliminate Government Specs & Standards.
- Use of Performance & Guide specifications.
etc.

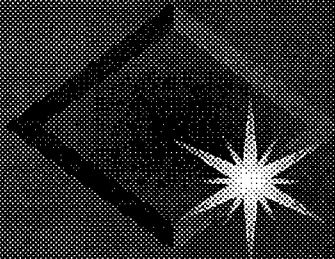

Acquisition Reform

Documents not Requiring Waivers

The following documents may be used without a waiver:

- a. Performance specifications (“identified by “MIL-PRF-”).
- b. Guide specifications (as described in DoD 4120.3-M, Appendix H).
- c. Commercial Item Descriptions.
- d. Interface Standards.
- e. Standard Practices.
- f. Military Practices.
- g. Non-government Standards.

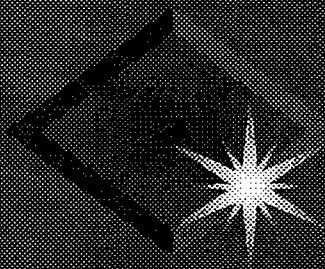

Acquisition Reform Documents Requiring Waivers

DoD program offices and buying commands shall obtain waivers when citing as requirements in solicitations, the types of documents listed below:

- a. Military specifications and standards.
- b. Program unique detail specifications that define exact design solutions.
- c. Federal specifications and standards.
- d. Any type of government or non-government specification or standard that describes management or manufacturing processes in a Major Defense Acquisition Program.

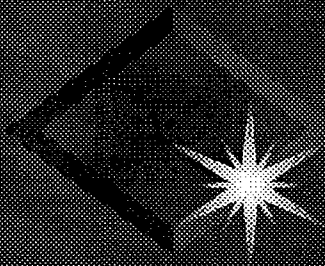

Acquisition Reform

Status of Fuze Related Specs & STDs

Army waived the following:

MIL-STD-331B
MIL-STD-1316D
MIL-STD-1751
MIL-STD-1911

Navy waived the following until August 7, 1999:

MIL-STD-331B
MIL-STD-1316D
MIL-STD-1512
MIL-STD-1751
MIL-STD-1901
MIL-STD-1911

Air Force requires waivers for all Specs & STDs

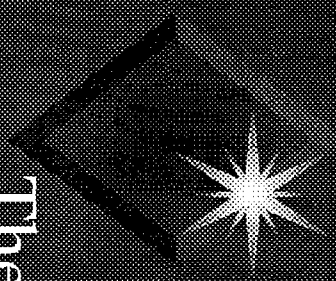

Acquisition Reform

The Office of Munitions would like to here your concerns regarding the impact of Acquisition Reform on the munitions & fuzing community

- Is Acquisition Reform working OK?
- How can we improve?
- Are profit margins & safety margins being compromised?

★ Please fill out the cards available at the back of the room and place them into the box. ★

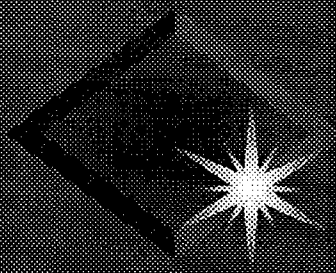

Backup Charts

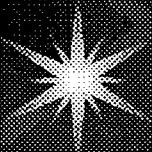

FISCAL TRENDS

Army Fuze Procurement

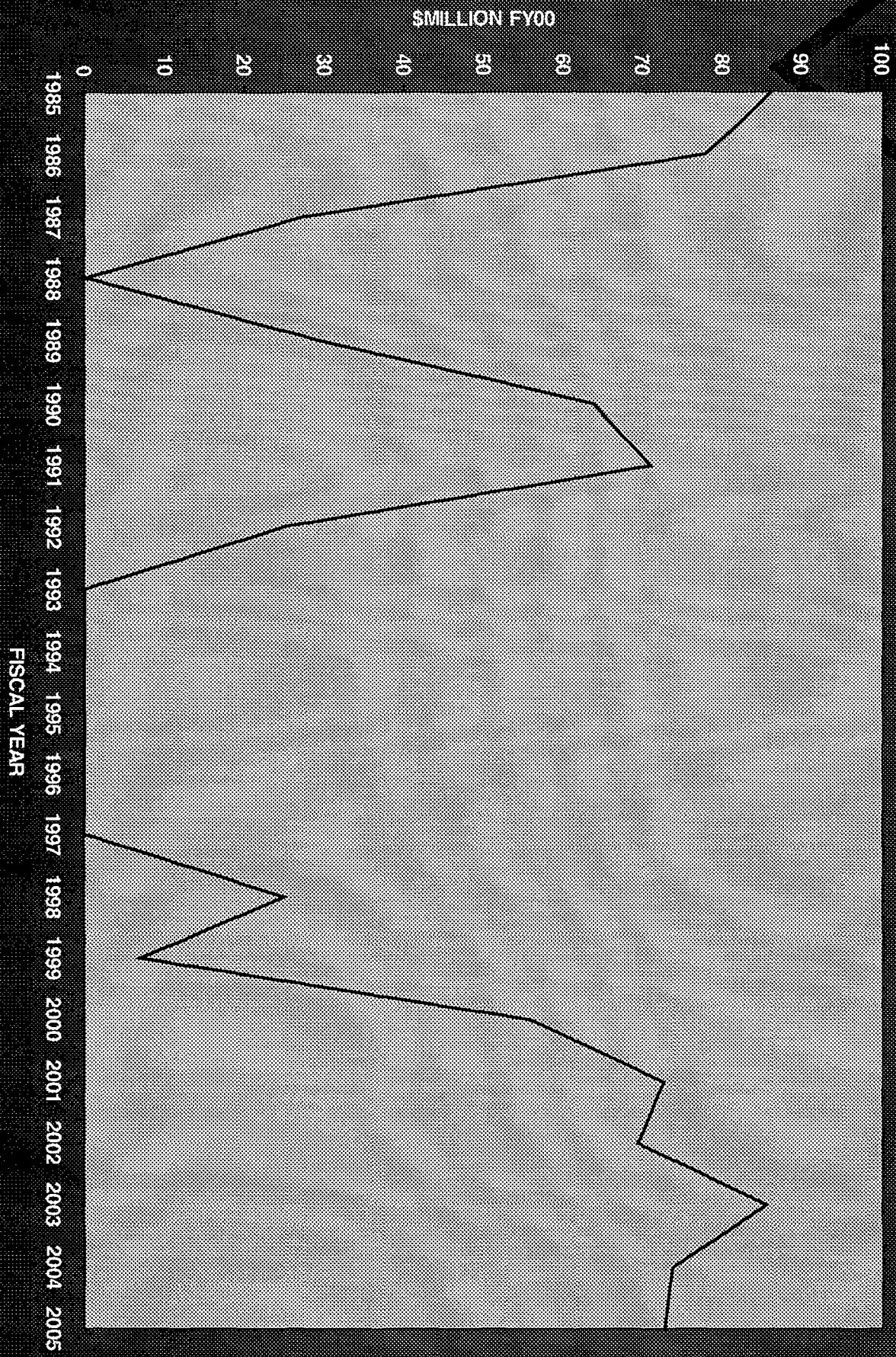

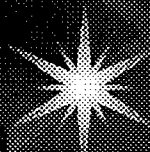

FISCAL TRENDS

Air Force Fuze Procurement

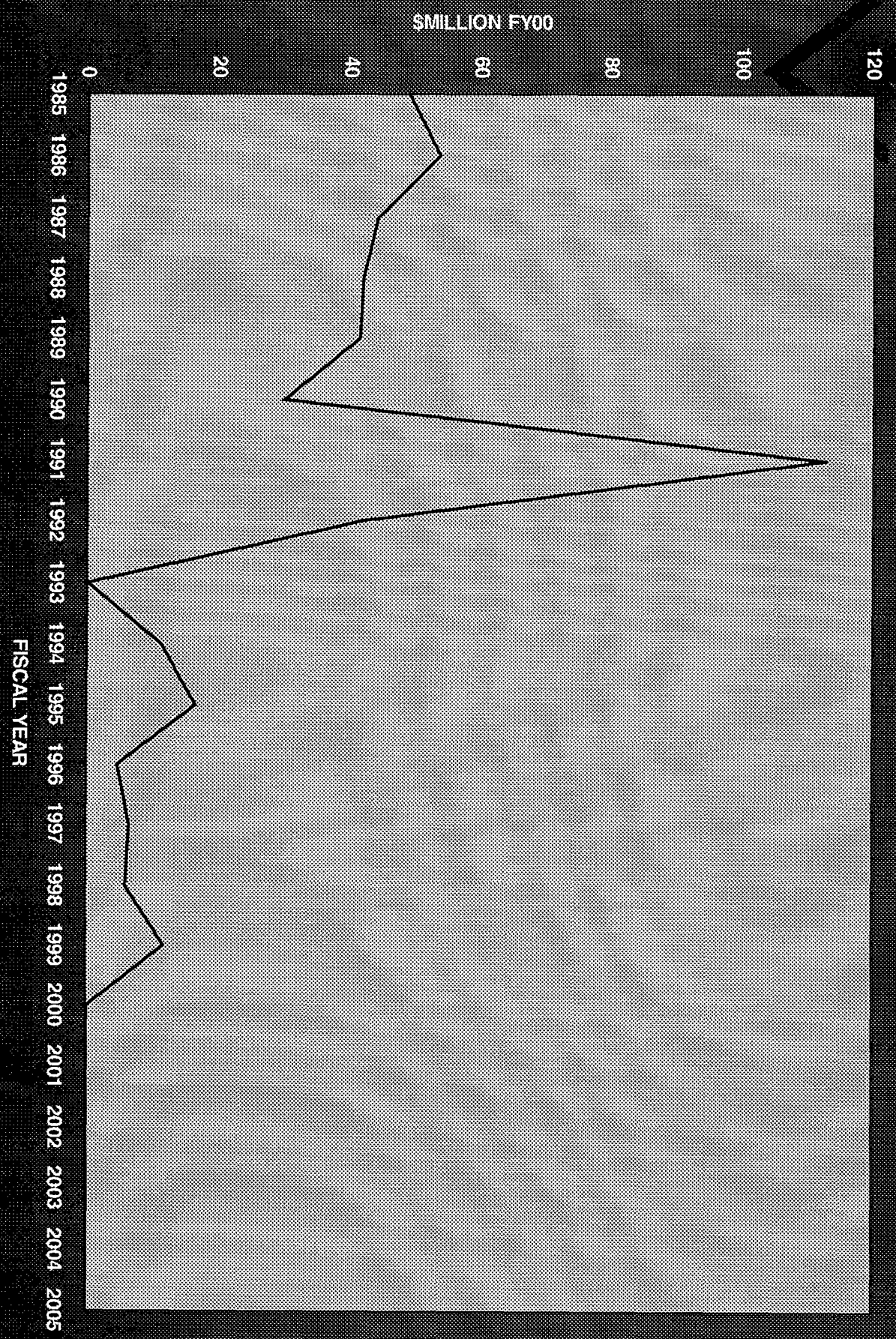

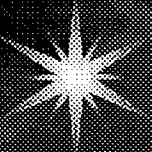

FISCAL TRENDS

Navy / USMC Fuze Procurement

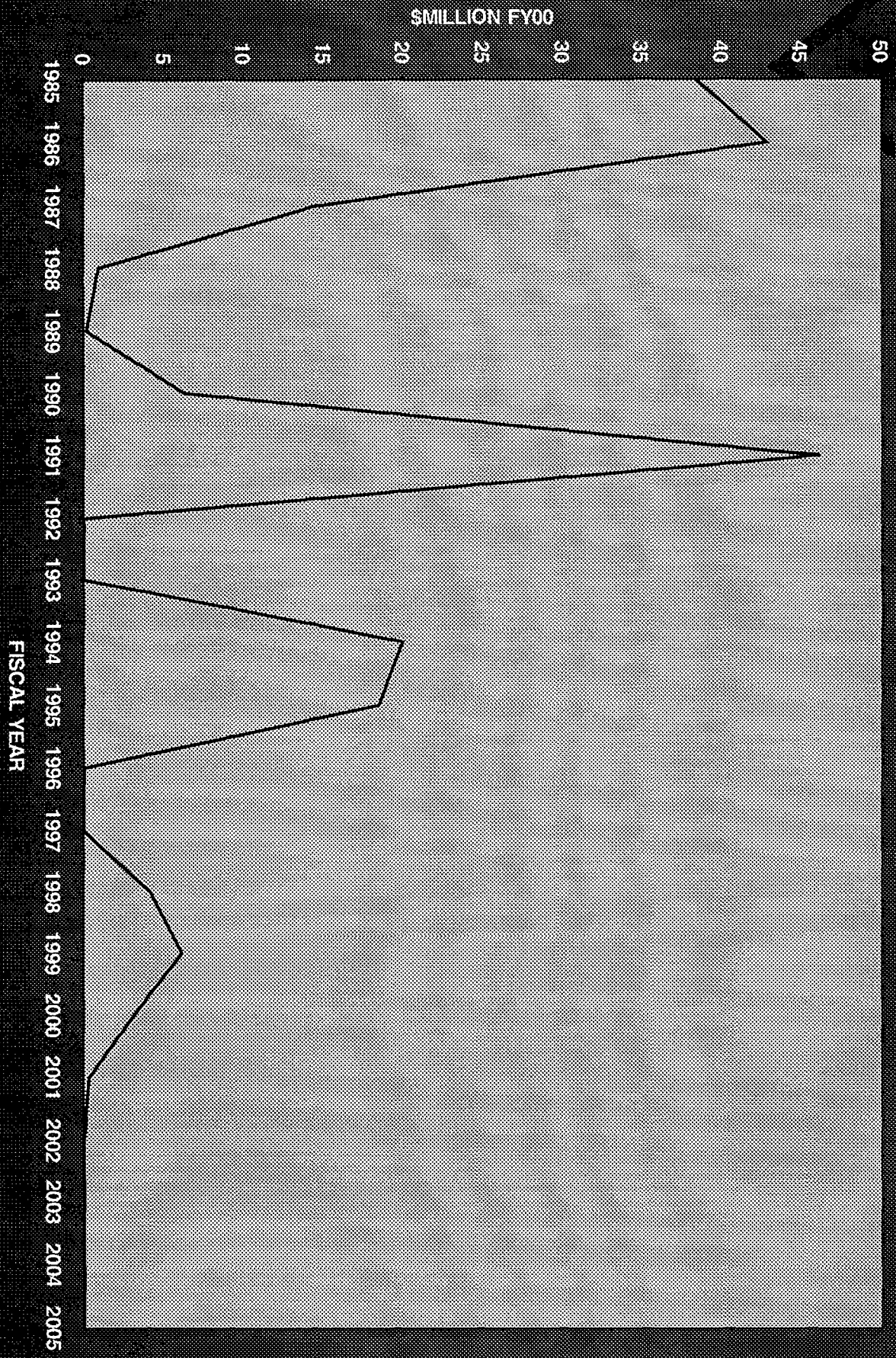

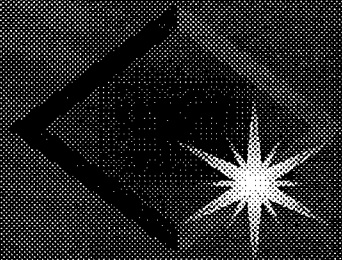

NATO INSENSITIVE MUNITIONS INFORMATION CENTRE (NIMIC)

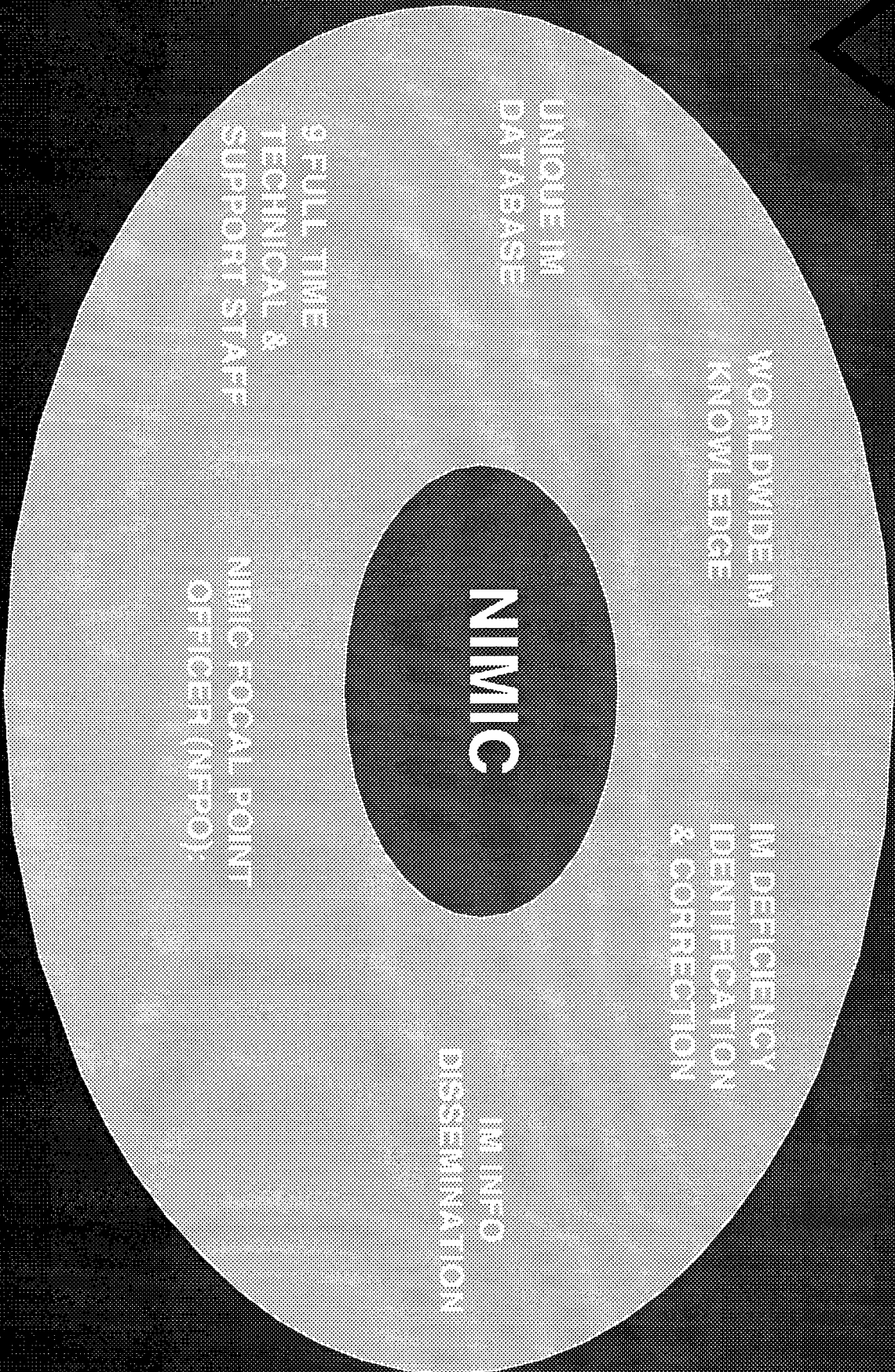

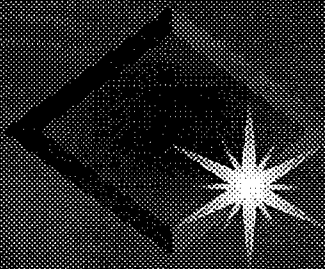

NIMIC PROCESS/PRODUCTS

RAW MATERIALS:

- MEMBERSHIP FEES (\$ U.S. 1.1 M/YR)
- DATABASE DOCUMENTS
- STAFF EXPERIENCE
- TECHNICAL CONTACTS



PROCESSES:

- NIMIC-UNIQUE DATABASE
- DATABASE POPULATION
- EXPERT ANALYSIS
- DATA ANALYSIS
- ISSUES IDENTIFICATION
- INTERFACE W/PRACTITIONERS
- IM TECHNICAL WORKSHOPS

NIMIC PRODUCTS:

- ENHANCED DATABASES
- TECHNICAL/POLICYADVICE
- POLICY/STDS ESTABLISHMENT
- IM ORIENTED SOFTWARE
- IM ISSUE REPORTING/RESOLUTION
- OUTPUT FROM WORKSHOPS



US ARMY
TANK-AUTOMOTIVE AND ARMAMENTS COMMAND
ARMAMENT RESEARCH, DEVELOPMENT AND
ENGINEERING CENTER
(TACOM-ARDEC)

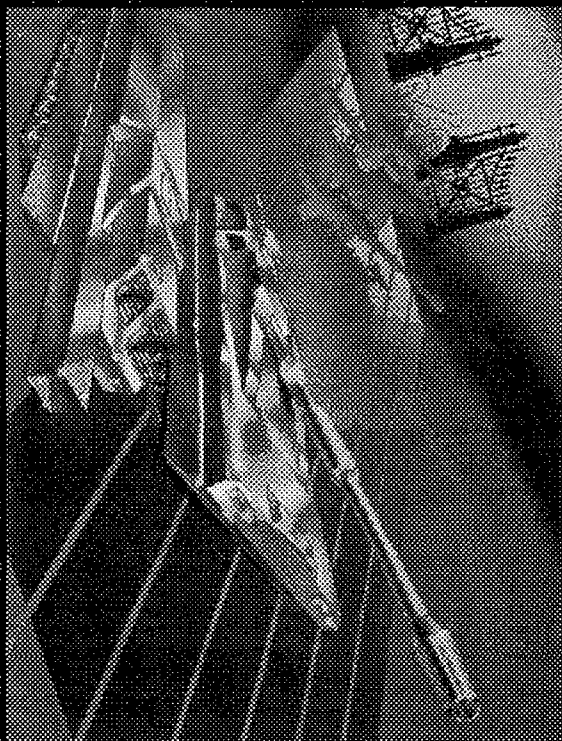

AMC

TACOM

Future Challenges and Opportunities in Fuzing

Presented to

43rd Annual Fuze Conference

Presented by

BG John P. Geis

Commander, TACOM-ARDEC

7 April 1999

Outline

- TACCOM-ARDEC Vision/Mission
- TACCOM-ARDEC Future Thrusts
- Enabling Technologies
- Fuzing Challenges
- Future Fuze Technologies
- Summary

Tank-automotive & Armaments Command

Mobility

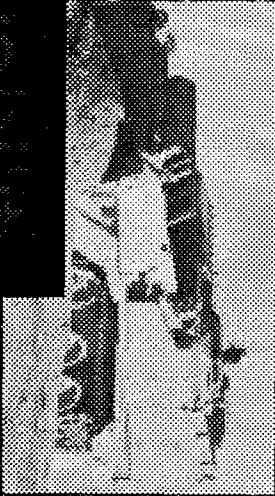
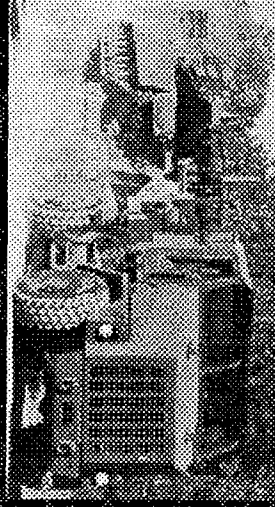
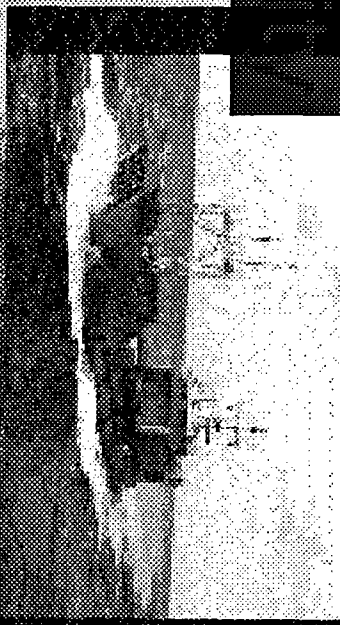

Firepower

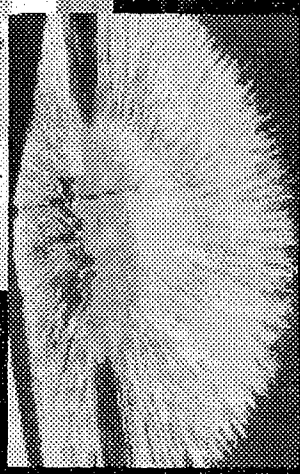

VISION

Provide Overwhelming Firepower for Decisive Victory

MISSION

Fire Support



Mounted Operations

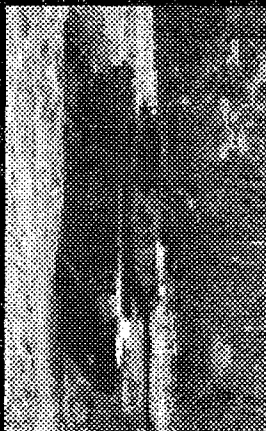

Combat Service Support

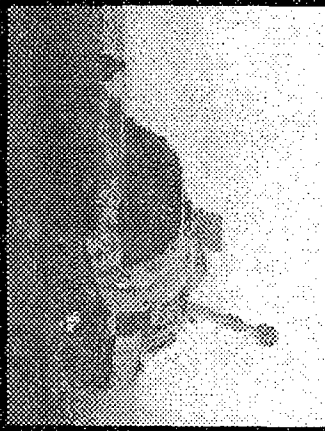

Special Operations



Dismounted Operations

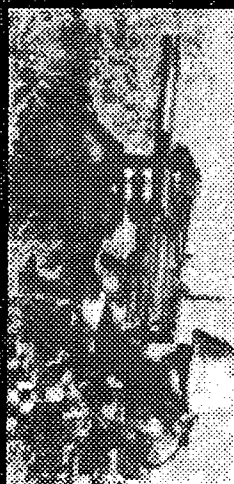

Counter - Mobility



Aviation Armament



Evolving U.S. Land Warfare Doctrine

Path to the Future

ARMY AFTER NEXT

Capabilities



Current Force

2005-2010

- Digitized Force
- Information Dominance
- System Upgrade to Maintain Overmatch



Future Combat Vehicles

2025

- World Class C4ISR
- Medium Weight Force
- Evolutionary Technologies
- Reduced Logistics Tail

- Full Spectrum Dominance
- New Systems with Physical Agility

S&T Implications for AAIN:

Future Combat Vehicles



- Mobility
 - All Terrain Capable
 - Road Speed 120 km/hr
 - Sustained Cross-Country 75 km/hr
 - Operating Range 800-1500 km
 - No More Than 15-20 tons
 - C130 Like Deployable
- Firepower
 - NLOS & LOCC Capable
 - Multi-Purpose Munitions
 - Redundant, Long Range Target Detection
 - System Lethality to 50 km
 - Advanced Munitions
- Protection
 - Lightweight Protection Materials
 - Low Observable Technologies
 - Ballistic Crew Protection
 - Active Protection
 - NBC Protection
 - Threat Awareness with 30 km

Advanced Artillery Munitions

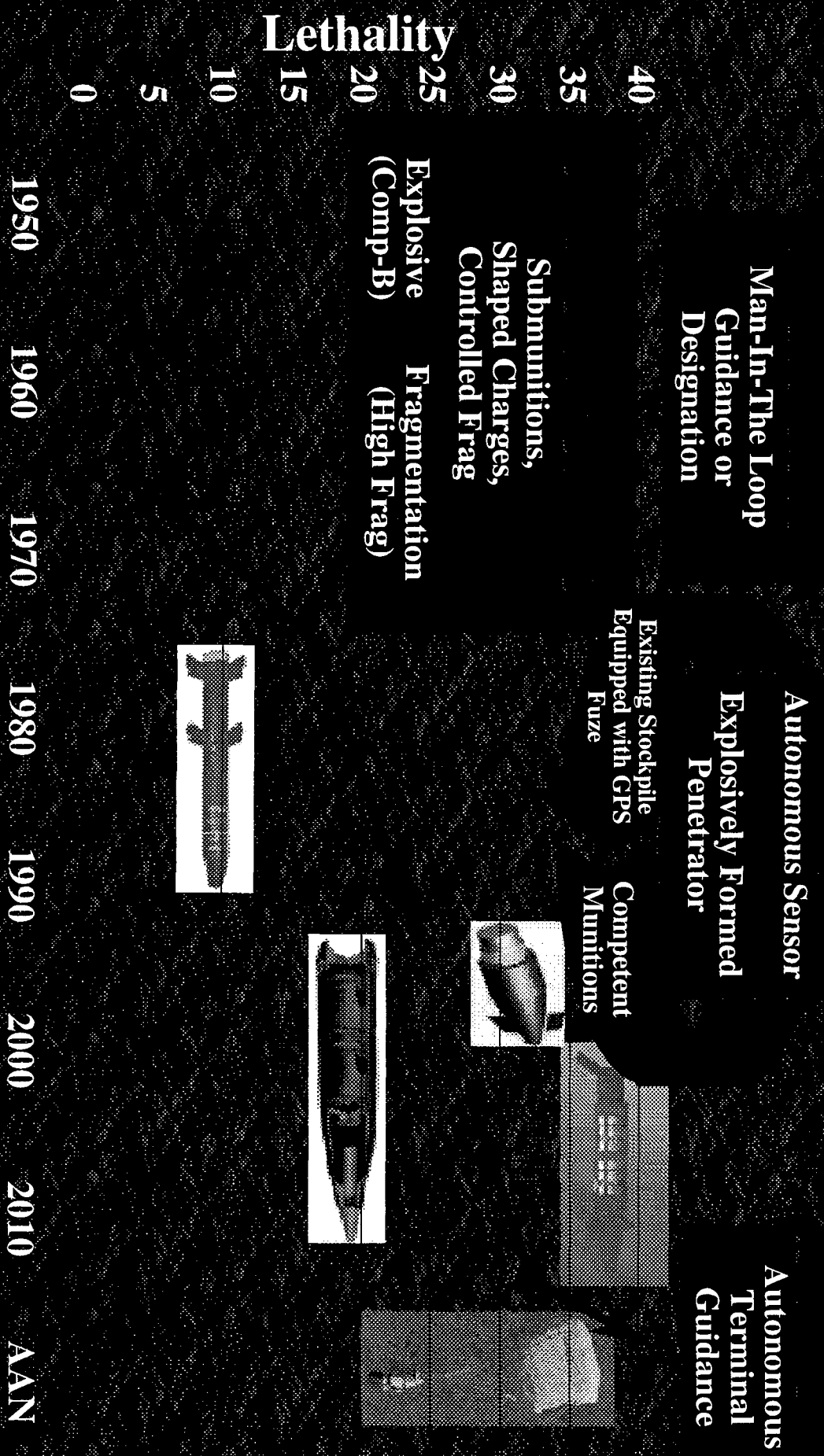

XM1982 Extended Range Artillery

- Fire & Forget
- GPS / IMU Guidance
- Modular Design
 - DPICM
 - Type Classified 4QFY01
 - SADARM
 - Type Classified 4QFY04
 - Unitary
 - Type Classified 4QFY05
- Increased Range
 - Paladin/M198/JLW155: 37 Km
 - Crusader: 50 Km

DPICM

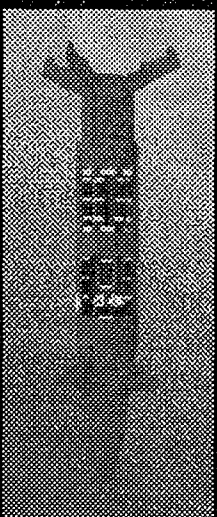

Transitioned to EMD
Contractor Selected:
Raytheon/TI Systems

Will Outrange All World Artillery Systems

Low Cost Competent Munitions

- Low Cost GPS/SINS MEMS Technology
- 3 Variants
 - Auto-Registration (Army Lead)
 - Range Correction (UK Lead)
 - Range & Deflection Correction (Navy Lead)
- Increased Firepower
- Dramatic Reduction in Logistics

LCCM Concepts

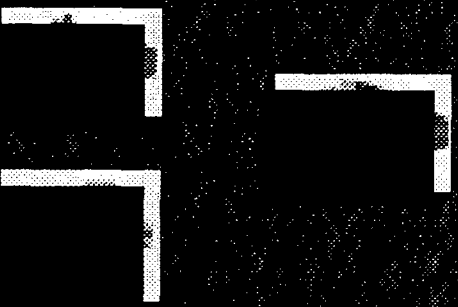

I
II

Range x Deflection

Baseline - Predicted Fire
742m x 246m

I - Auto Registration
518m x 152m

II - Range & Deflection
Correction - 70m x 56m

M80 Family of Submunitions

- The M80 Submunition was Developed by TACCOM-ARDEC with the M234 SD Fuze for Reduction of Duds
- Army Applications
 - XM982 (155mm)
 - Extended Range MLRS
- Navy Applications
 - ERGM (5 inch)
 - Advanced Gun System

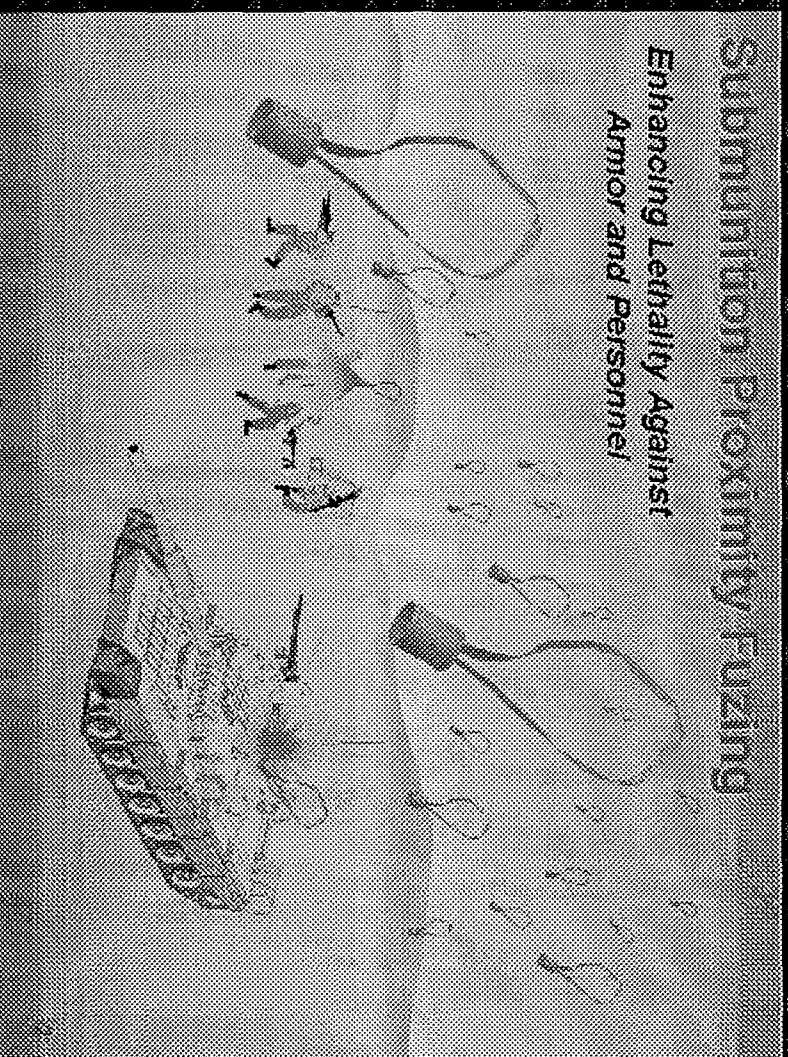

XM782 Multi Option Fuze for Artillery

- **Four Function Setting: Prox, Time, PD & Delay**
- **Simplifies Logistic Burden by Reducing Load Mix Combination**
- **Supports Crusader Rapid Rate of Fire**
- **All Functions Auto Settable**
- **Compatible with Current 105mm and 155mm Projectiles**

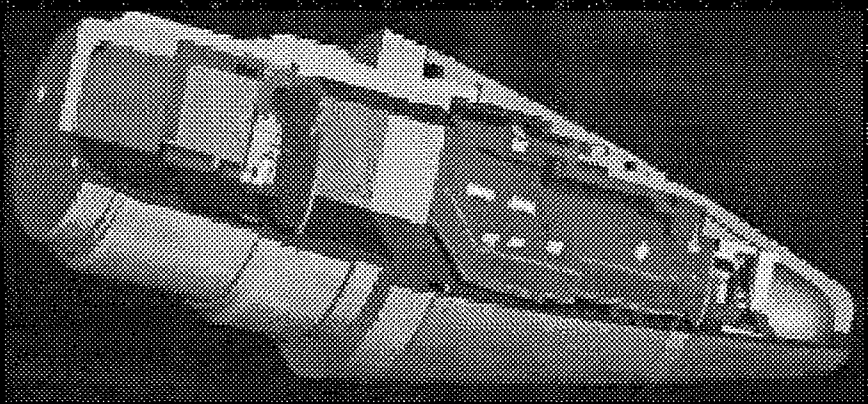

XM782 MOFA

Precision Guided Mortar Munition

- GPS/INS & Laser Guided Mortar Munition
 - Pinpoint Accuracy
 - 12+ Km Range
- Provides Responsive Standoff Defeat of High Value Targets
- Reduced Collateral Damage
- Improved Survivability and Accelerated Enemy Defeat
- Improved Deployability and Logistics

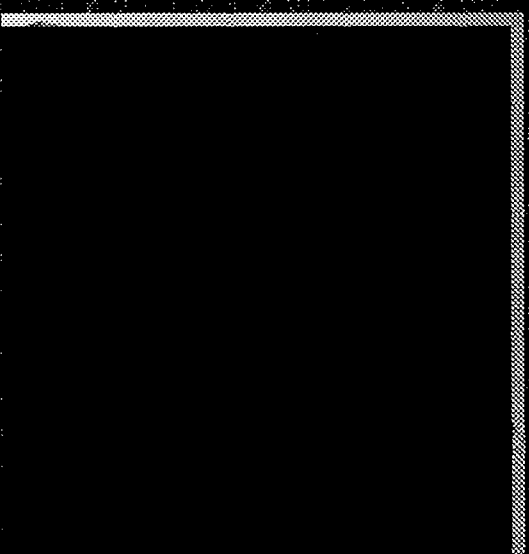

Precision Fire for the 21st
Century Infantry

Anti-Armor Lethality

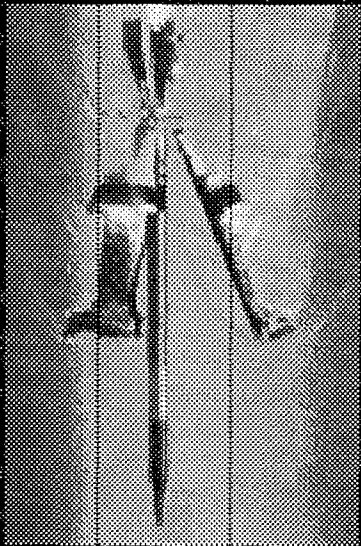

1A3329FEA

Advanced Penetrator
Technology

1A3329FE5

Thermoplastic Composite Sabot
Higher Velocity Propellant

1A3329A2

Improved DU Processing
Thermoset Composite Sabot

1A3329AJ

Longer Rod

1A3329

Tungsten Replaced with
Depleted Uranium (DU)

1975

1980

1988

1995

2003

2008

2012

PENETRATION

Tank Extended Range Munition (TERM) Concepts

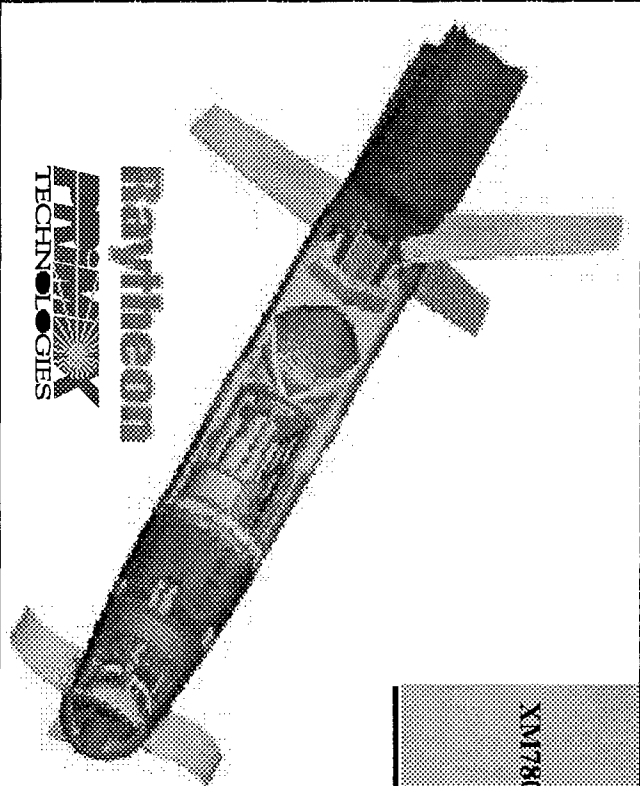

TERM-TA Concept

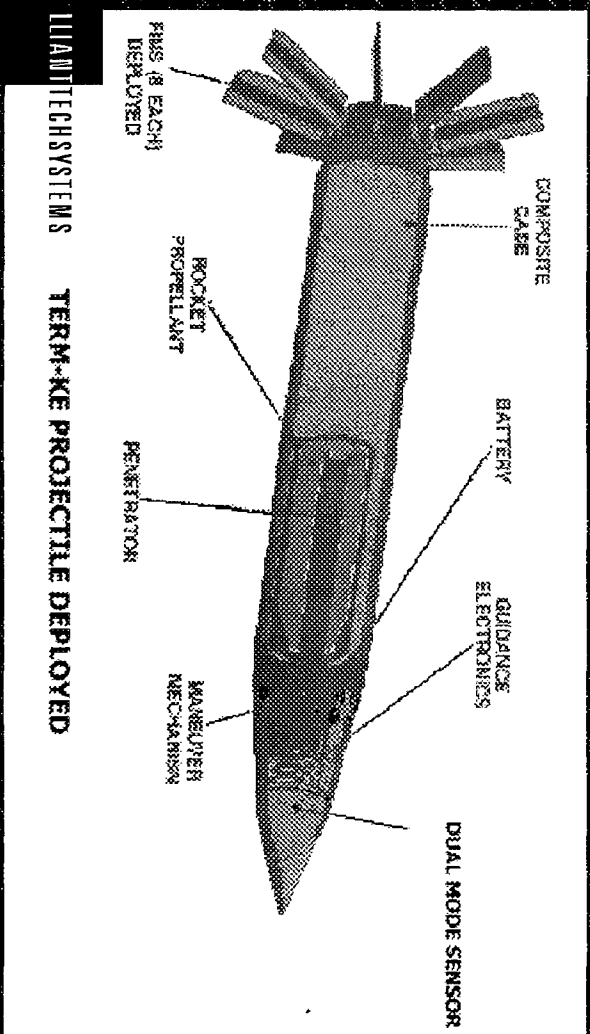

LIANTTECHSYSTEMS TERM-KE PROJECTILE DEPLOYED

Objective Crew Served Weapon



- 25mm Airbursting & Armor Piercing Munitions
- Defeats Targets that the 7.62mm M240 and M2 Cannot (Defilade Targets)
- Miniaturized High "G" (105,000 G's) Electronic Time Set Fuzing
- Greater than 60% Reduction in System Weight
- 50% Reduction in Time-of-Flight to Maximum Effective Range vs. 40mm
- Greater than 500% Probability of Incapacitation Increase

Objective Individual Combat Weapon

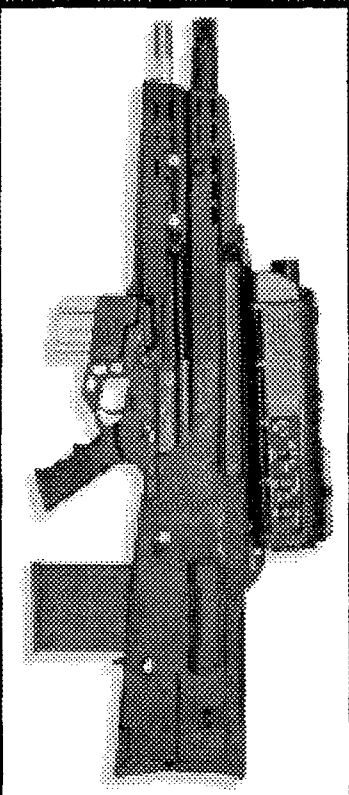

- Dual Capability - 20mm Air Bursting & 5.56 Munitions
- Defeats Targets that the M16 Cannot (Defilade Targets)
- Doubles Stand-Off Range to 1000+ Meters
- > 300% Probability of Incapacitation Increase

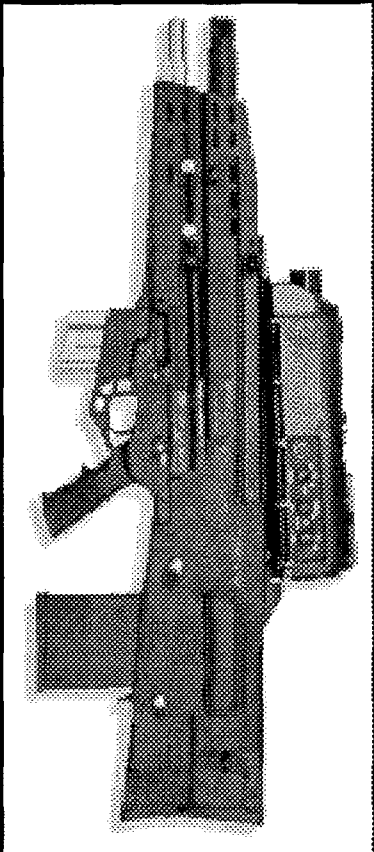

OICW Video

MEMS (Micro-Electromechanical Systems) OICW (20mm)

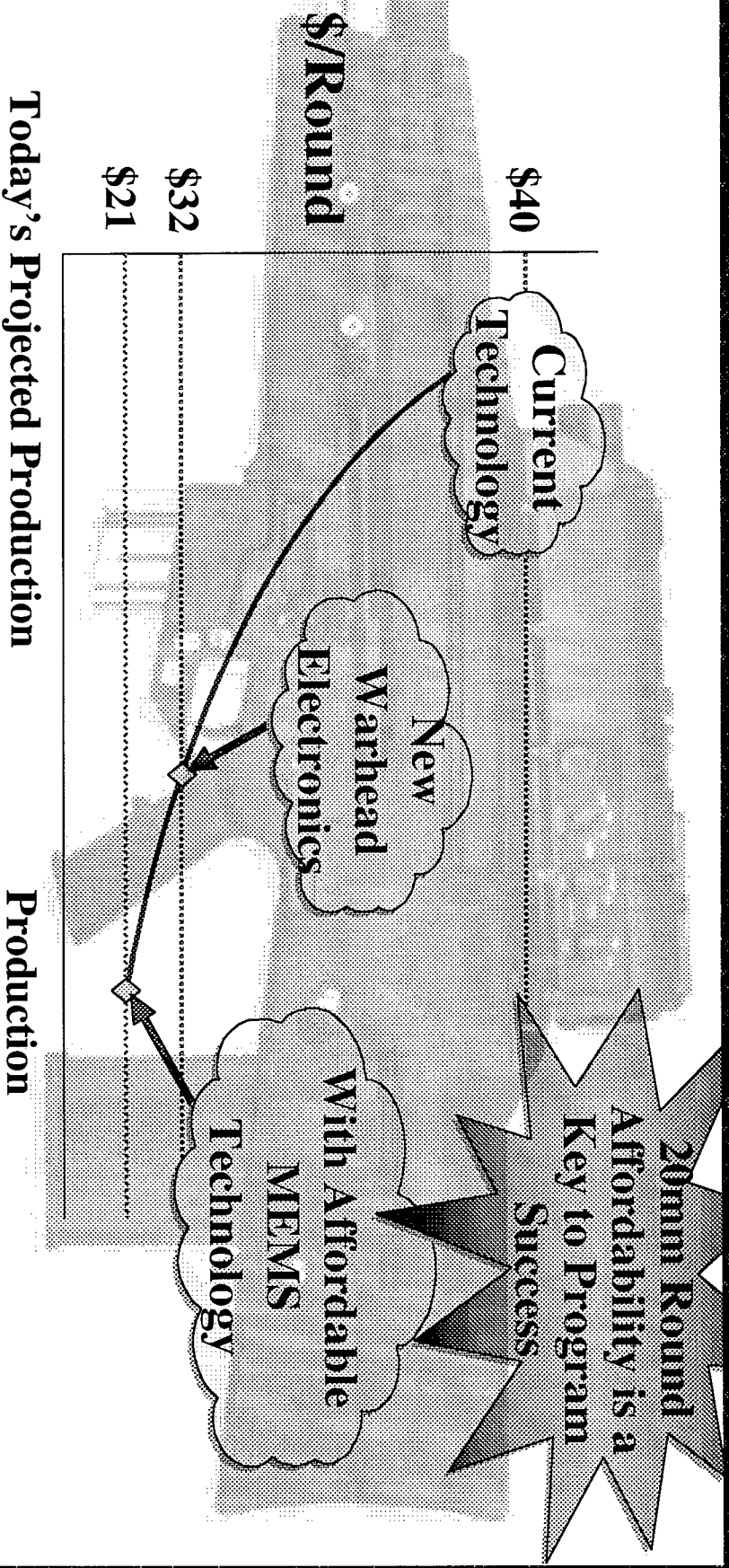

Fuze Technologies for AAN

- **Advanced Sensors and Algorithms**
- **Guidance Integrated Fuzing**
- **MEMS Technology for Fuzing Applications**
- **Miniature Detonators and Initiators**
- **“Super Hard” Fuzes, to Withstand High Shock Environments**
- **Compatibility with Electrothermal Chemical and Electromagnetic Launched Munitions**
- **Miniature Power Sources**

Key Fuzing Needs Identified by PwMs

Tech Base Development

- Inductive Auto-Setting ✓
 - Fuzes for Tank Ammo ✓
 - Miniaturization (MEMS) ✓
 - Miniaturized Detonators ✓
 - Time Based Fuzes for Med Cal ✓
 - Defeat of Air Targets in Clutter
 - Improved Power Sources
 - Prox Fuzes for Med Cal
 - Reduced Voltage ESAs
 - Second Safety Sensors
 - Submunition Prox Fuzing
- ✓ Indicates Funded Army Effort

Tech Base Return on Investments

2000s

1990s

1980s

1970s

**An Investment in Fuze
Technology Allows Transition of
Critical Technology Into
Advanced Munitions Systems**

Summary

- ARDEC's Strategic Plan Will Support Force XXI and Army After Next
- Future Armaments Must Provide Increased Lethality and Performance While Maintaining Affordability
- Fuzes Key to Realization of this Goal
- Future Fuzes Will Require Pursuit of Critical Enabling Technologies

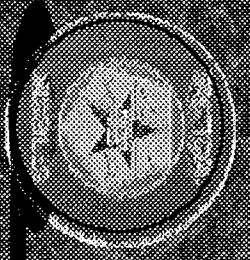

THE HISTORY OF THE MISSISSIPPI VALLEY

MISSISSIPPI VALLEY
MISSISSIPPI VALLEY



MISSISSIPPI VALLEY



MISSISSIPPI VALLEY



MISSISSIPPI VALLEY



MISSISSIPPI VALLEY

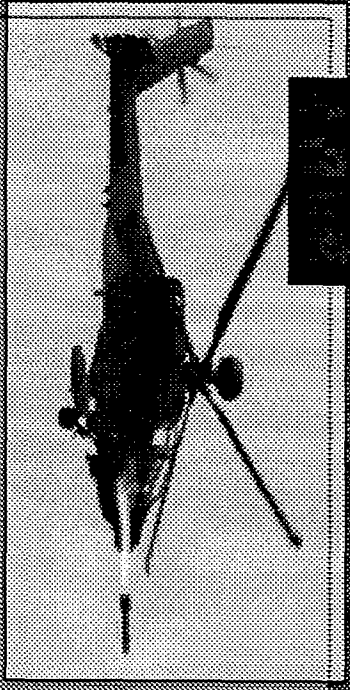

MISSISSIPPI VALLEY

PROGRAM EXECUTIVE OFFICER TACTICAL MISSILES

MISSION

Provide the American soldier with the finest, combat effective, tactical missile systems in the world in a timely and cost-effective manner.

GOALS

- ✦ Excel beyond all others in fielding the best tactical missile systems in the world.
- ✦ Effectively team with industry.
- ✦ Build the Army Acquisition Corps of the future.
- ✦ Mature and weaponize critical technologies for the Army After Next. First Digitized Division / First Digitized Corps.
- ✦ Reduce the Life Cycle Cost of our missile systems by 20% during the period FY98-FY00.

VISION

A world-class government / industry team that gives the American soldier an unparalleled, overmatch tactical missile capability that allows our Army to fight and win the next conflict with minimal casualties in the shortest time possible.

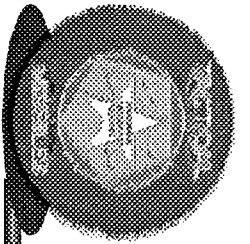

PEO TACTICAL MISSILES BOS

TOW
ITAS
IBAS
LOSAT
JAVELIN
BRADLEY T2SS

LAUNCHER
MLRS ROCKET
ARMY TACMS-BAT

HELLFIRE II
LONGBOW

ACCOMPLISHING THE MISSION INVOLVES WORKING HAND-IN-HAND
WITH THE COMBAT DEVELOPER AND WARFIGHTERS

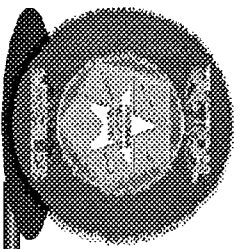

ONGOING INITIATIVES

HTI

- CCAWS & 2d Gen FLIR
 - Structured Relationship between PMS
- HTI = Good Program Management
 - Bottom Up
- HTI at DA Level
 - Complements Existing Good Business Practices
 - Creates Advocacy for common solution

IBAS

- Minimum Commonality Baseline (80% SW, 40% HW)

LOSAT

- Input to 2d Gen FLIR & Fire Control System Benefits from IBAS & IBAS

ATACMS

- GEM III GPS Receiver from MLRS IPPS

JAVELIN

- Uncooled FPA (BARPA)
- Enhanced Producibility EST

HIMARS

- Calb Armor from Commercial Linousines
- IFCS from M270A1
- Bradley Calb Air Filtration

HELLFIRE

- Common ESALF Development with Javelin

LONGBOW

- Advanced Guidance Package, Common IMU, Common ESALF, Navy test set

PSI BAT

- ATIP from Comanche, Common warhead with Javelin

MLRS

- Self Destruct Fuse

GMLRS

- GOTS Inertial Measurement Unit

CAPS

- ATD used ATACMS Block I Guidance Software
- PAC-2 FTS
- Center of Excellence (TOW, HELLFIRE, LONGBOW, Javelin)

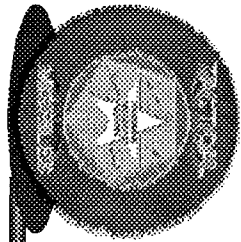

A GOOD HTI OPPORTUNITY

- **MULTIPLE USERS**
- **POTENTIAL COST SAVINGS**
- **COUNTER-MEASURE RESISTENT
(WAR FIGHTING DOESN'T REQUIRE
VARIETY)**

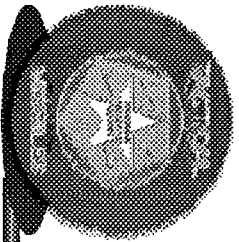

HTI FUZES FOR TACTICAL MISSILES

- **COMMON ELECTRONIC SAFE AND ARM FUZE (CESAF)**
- **FUZES FOR MLRS**
 - XM451
 - XM235
- **HARD TARGET SMART FUZE (HTSF) / MULTIPLE EVENT HARD TARGET (MEHTF)**

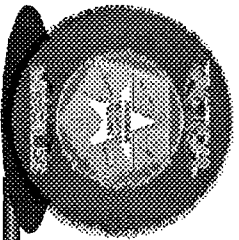

“COMMON” ESAF

- LOCKHEED-MARTIN INTERNAL DEVELOPMENT
- ORIGINALLY INTENDED FOR JAVELIN, HELLFIRE, AND BAT WARHEADS
- MINOR DESIGN PROBLEMS IDENTIFIED DURING DESIGN VERIFICATION TESTING (DVT)
 - CORRECTIVE DESIGN MODIFICATION VALIDATED SECOND DVT
- CESAF MISSED HELLFIRE IM INTEGRATION TEST WINDOW

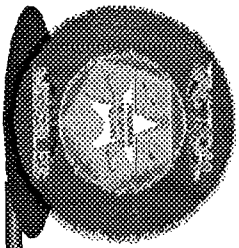

CESAF REMAINING TESTS

- **FEB/MAR 99 FULL QUALIFICATION**
- **JAVELIN SYSTEM LEVEL ENVIRONMENTAL / FLIGHT TESTS APR-OCT 99 (17 ROUNDS)**

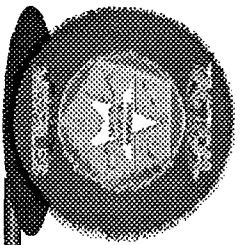

CESAF PRODUCTION

- **REMAINING JAVELIN PRODUCTION**
 - **FRP3 (4057 MISSILES)**
 - **MY2 PROCUREMENT (18,051 MISSILES)**
- **HELLFIRE STAYED WITH CURRENT ESAF FROM EDI AFTER SIGNIFICANT COST REDUCTION**
 - **COMPETITION DROVE SAVINGS**

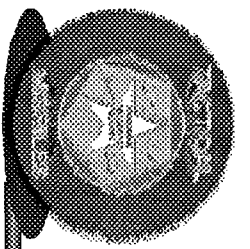

ER-MLRS DESCRIPTION

The ER-MLRS Program: Three Pronged Approach

- Modify Current Rocket
- Soft Launch (No-Load Detent)
- Modify Current Grenade (Self Destruct Fuze)

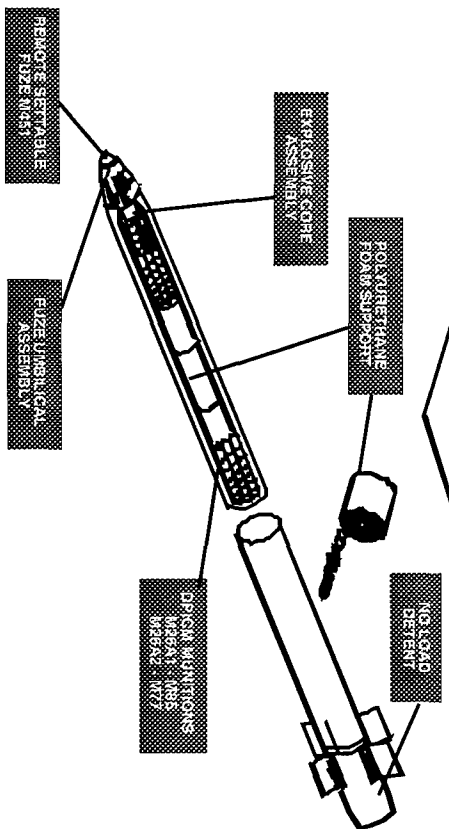
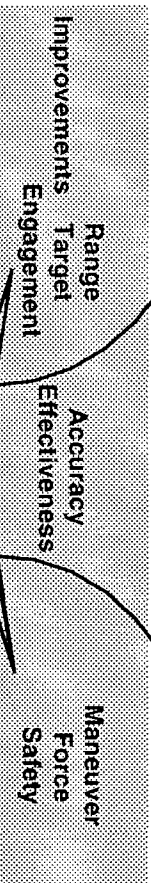
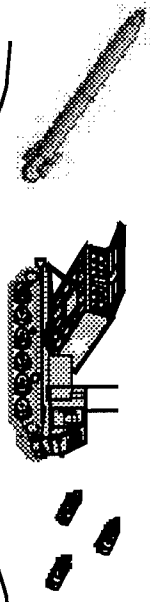

System Description

Description: The ER-MLRS is a free-flight, area fire, artillery rocket designed to enhance the capabilities of the MLRS M26. The M26A1 version is loaded with the XM85 grenade; the M26A2 version is loaded with the M77 grenade.

Characteristics:

- Max Range: 45 km
- Rocket Length: 3,937 mm
- Rocket Diameter: 227 mm
- Warhead Length: 1,686 mm
- Motor Length: 2,251 mm
- Launch Weight: 296 kg
- Grenades: 518

Capability Improvements (KPP):

- Extended range to 45 km
- Improved accuracy
- Enhanced effectiveness
- Improved maneuver force safety

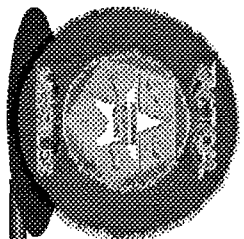

EXPLODED VIEW OF THE XM451 FUZE ASSEMBLY

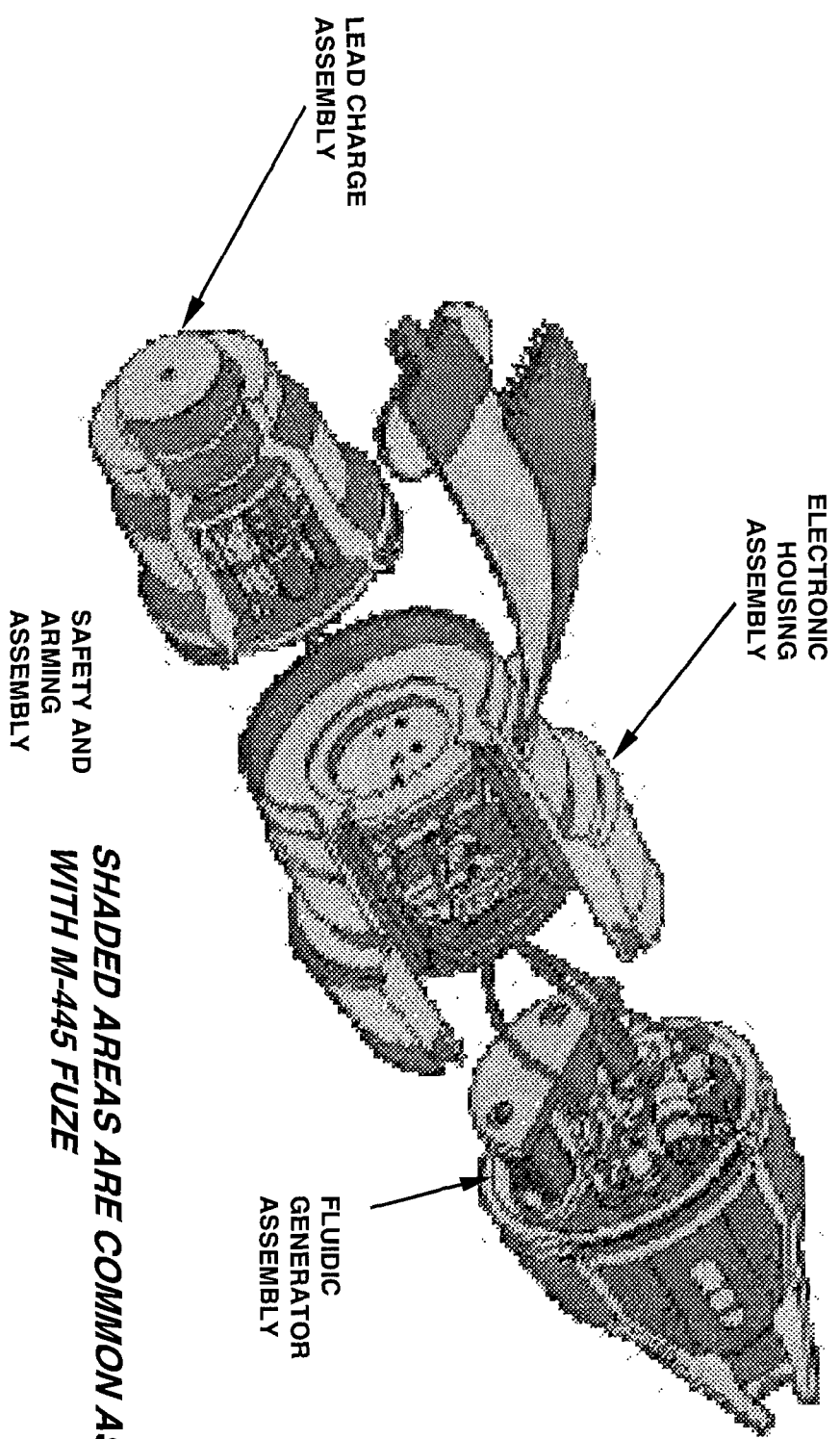

SHADED AREAS ARE COMMON ASSEMBLIES WITH M-445 FUZE

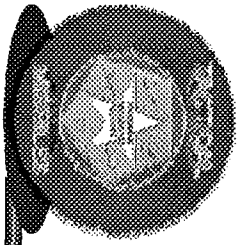

ER-MLRS: XM451 NOSE FUZE

- XM451 failures during development (monolithic impacts)
 - Extensive root cause completed by Govt / Industry Team
- Root cause identified
 - Redesign fluidic generator nozzle body to reduce stressing effects on generator components from higher ER dynamics
- Extensive lab and flight test program completed
 - Development 17/18 Flts 94.4% Success
 - Production 48/48 Flts 100% Success
- ASIC redesign completed, qualified, and incorporated
- XM451 fuzes currently being delivered to LMVS for ER, US and FMS production

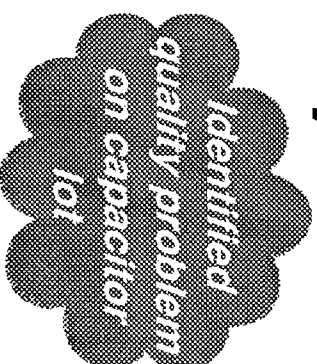

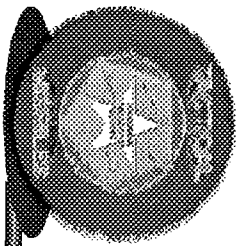

XM235 SELF DESTRUCT FUZE ARMING / DETONATION SEQUENCE

1.

SAFETY SPIRAL
SAFETY PIN

SHUNT
SAFETY PIN

**SAFETY PINS REMOVED; GRENADES
LOADED INTO ROCKETS**

2.

GRENADES DISPENSED

3.

SAFETY
SPIRAL
(ACTIVATES
BATTERY)

SHUNT

RIBBON

**RIBBON DEPLOYS; SLIDE MOVES;
SHUNT COMES OFF; SPIRAL SAFETY
ROTATES**

4.

BATTERY

ACTIVATION
SPRING

LEVER

SAFETY
BALL

**BALL FALLS; SPRING DRIVES
LEVER INTO BATTERY**

5.

CAPACITOR

3 MINUTE
TIMER

WIRING GRID

**BATTERY CHARGES
CAPACITOR; TIMER TIMES
OUT; WIRING GRID ENERGIZED**

6.

EED

M55
DETONATOR

ELECTRO EXPLOSIVE DEVICE (EED)

**EED EXPLODES;
M55 DETONATOR EXPLODES**

7.

- OR -

FUZE
DISABLED

GRENADE
EXPLODES



SELF DESTRICT FUZE (SDF) STATUS

Background

- Development testing (Mar - Apr 96) demonstrated 2.63% SDF dud rate vs. 1% required 12% primary vs. 5% goal
- Design improvements identified
- LRIP decision (May 96): prove 1% dud rate prior to ER-MLRS fielding

Progress To Date

- Ground / artillery / rocket tests (Oct 96 thru Dec 97) supported fixes to design
- Design Verification Tests 30 Mar - 2 Apr 98 (tactical mode)
 - Across all conditions: 0.64%
 - Weighted average (OMS):
0.48% met HDR requirement
- Began production of M26A2 (with M77): Feb 98
- Decision: 24 Apr 98

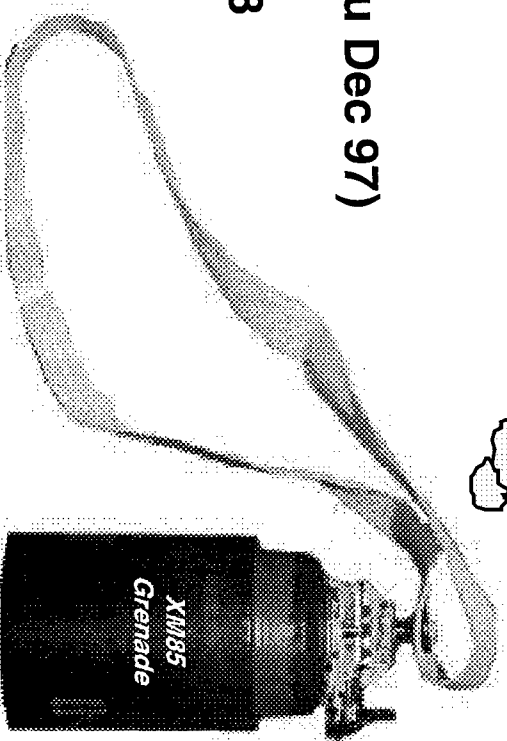
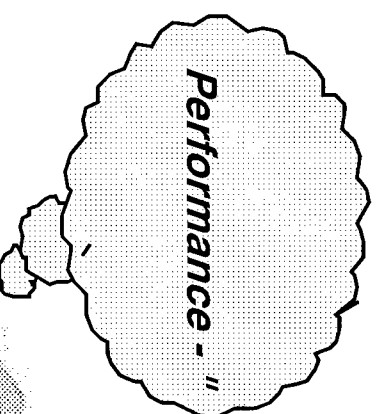

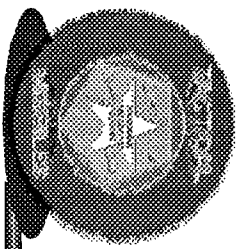

SELF DESTRICT FUZE (SDF) STATUS

Concerns

- Affordability: \$8.05 budgeted; \$10.54 price (GMLRS / M982)
 - Producibility: Automated equipment not completed to support loading of SDF into ER-MLRS
 - Five contract extensions to date
 - Complex SDF Design Configuration
 - No other supplier of SDF available
- ### Future Plans
- Develop additional SDF source in GMLRS EMD (EU partners): Aug 98 CBD Announcement
 - Continue low level engineering design effort to modify "old" mechanical fuze (M223)



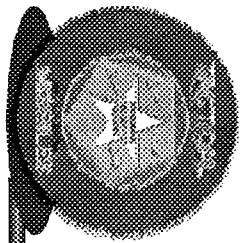

EARTH PENETRATOR PROGRAM

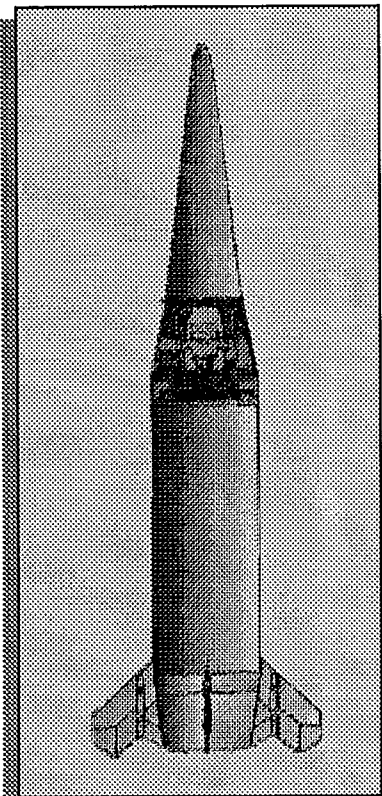
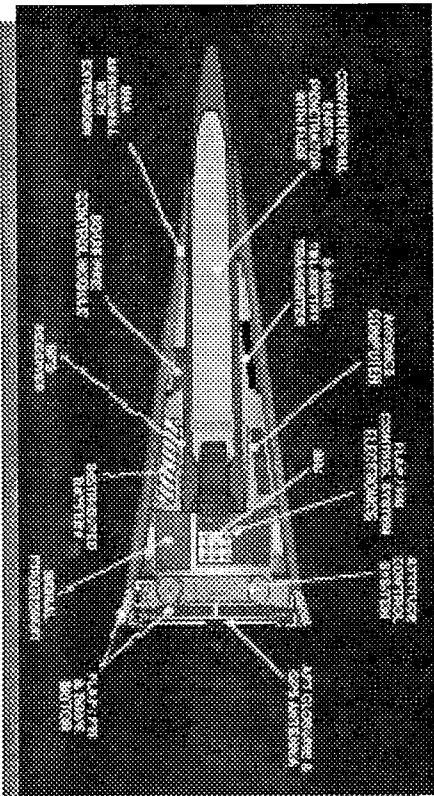

TACMS PENETRATOR DEMONSTRATION

- INTEGRATE NAVY M44 REENTRY BODY (RB) ONTO ARMY TACMS BOOST VEHICLE
- CONDUCT 3 FLIGHT TESTS BEGINNING IN FY01 AT WSMR TO DEMONSTRATE RB DELIVERY AND TARGET PENETRATION
- DELIVER & RESIDUALS FOR CONTINGENCY OPERATIONS FIRED FROM M270 LAUNCHER
- FY99 OSD FUNDING IDENTIFIED, AWAITING RECEIPT
- SSP FUNDED AT \$4M
- ARMY TACMS FUNDED AT \$4M
- OVERALL DEMO \$44.857M

HARD AND DEEPLY BURIED TARGET DEFEAT CAPABILITY AOA

- ONE OF 3 REMAINING INDIRECT ATTACK CANDIDATES
- DOWN SELECT 20 FY99 DAB IN AUG 99
- EMD FY03 WITH LRP DELIVERIES 05
- DIRECT ATTACK AIR FORCE WEAPONS (BIG BLU 2000, GUMB 10,000 LB BOMBS) DEFEAT MAJORITY OF TARGETS
- STRUCTURAL DEFEAT VERSUS FUNCTIONAL DEFEAT OF THE TARGET SET IS STILL AN ISSUE

BLOCK III

- DRAFT ORD RECEIVED AND COMMENTS ISSUED
- PB 00 BEGINS EMD IN 05 ACCELERATION OF BLOCK III WOULD LEVERAGE OFF (PB 00 FLIGHTS 01)

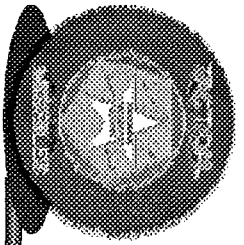

POTENTIAL FUZES FOR ATACMS EARTH PENETRATOR

Existing Hard Target Smart Fuze (HTSF) will potentially meet the Army's needs with minimal changes to current package.

- Army intends to leverage considerable Air Force investment in Hard Target Fuze developments
 - \$15-30M for HTSF
 - \$6M for MEHTF
- Potential Army savings \$10M, 24 months in development

Next generation HTSF, Multiple Event Hard Target Fuze (MEHTF) technology Advancements:

- High shock survivability
- Improved target sensing
- Multiple event capability

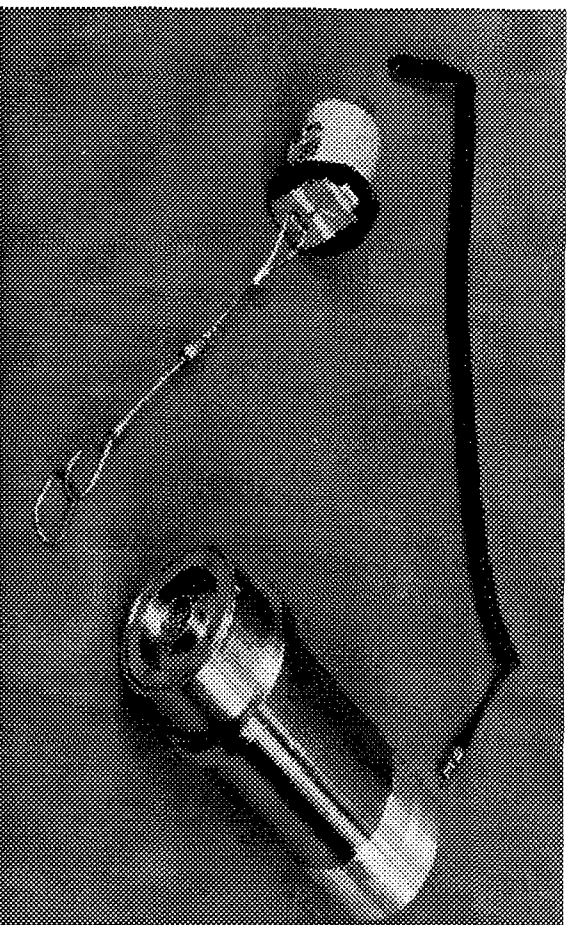

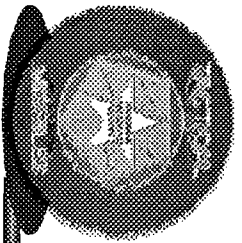

POINTS TO PONDER

- HTI IS SMART BUSINESS
- HTI IS A CHALLENGE WITH AN OPPORTUNITY TO EXCEL
 - OVERALL SAVINGS ARE POSSIBLE BUT COMPONENT DELAYS/FAILURES CAN HOLD-UP NUMEROUS SYSTEMS

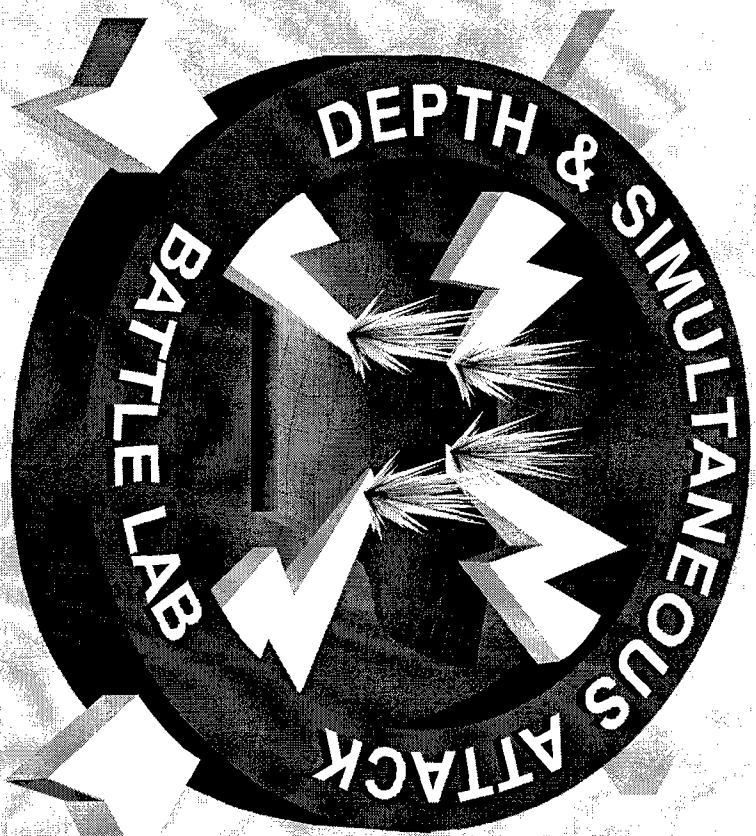

FUTURE FIRES

Colonel Peter S. Gormag

April 7, 1999

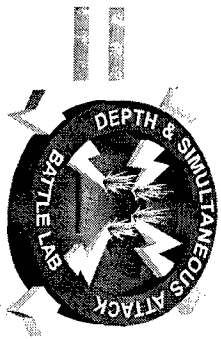

Agenda

- **Fires for the 21st Century
*Changing How We Fight***
- **Battle Lab Mission and the Organization
*Maintain the Army's Battlefield Edge***
- **Advanced Fire Support System (AFSS)
*Missile in a Box***
- **Silent Eyes (Science & Technology Objective)
*Detecting Targets Using Projectile Mounted Cameras***
- **Future Fires Command and Control
*Command and Control Fires on the Future Battlefield***

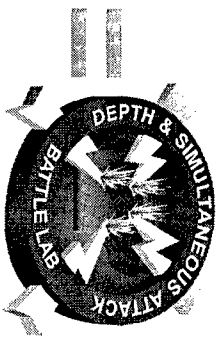

Effects Based Fires . . . A Paradigm Shift

- ✓ **Shift Focus to Terminal End . . . Effects Required Vice Who Delivers Them. Commanders Should Not Care Where Effects Originate From, Only That the Effect Desired Is Delivered on Time and on Target**
- ✓ **Shift From Past Use of Command Relationships and the Responsibilities Mandated by Those Relationships While Maintaining Responsiveness**
- ✓ **Broader Spectrum of On-demand Effects . . . Greater Reach Back Capabilities to Joint and Combined**
- ✓ **Holistic Look at "Required Effects" . . . Non-lethal May Be As Important As Lethal or More So**
- ✓ **Integration and Synchronization of All Effects From One Organization--the "Maneuvering of Effects"**

Fires for 21st Century Warfare

Effects Management

- ➔ Focus on the Terminal End . . . “Effects” Required Vice Who Delivers Them
- ➔ Organization Capable of Centralized Effects Management
- ➔ Packaging Effects to Provide Commanders Tactically Meaningful Options
- ➔ More Fluid and Flexible Distribution of Effects Through Enhanced Automation

Organizational Transformation

- ➔ Functionally Segregate Command From Effects Coordination
- ➔ Flatten Organizationally--eliminate FDCs and FSEs

Dynamic Force Tailoring

- ➔ Task Organize Systems Not Units
- ➔ Centrally Pool Resources at the Highest Tactical Level
- ➔ Mission Tailored Organizations -- Multiple Platforms

Munitions Centrality

- ➔ Shifts the Burden to the Munition
- ➔ Platform No Longer Drives Range, Precision

Effects Management

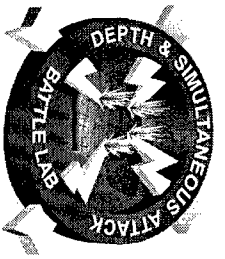

- ✓ Separate Command Functions From Effects Coordination Functions
 - ➔ FA BN and BDE Commanders Responsible for Deploying, Moving, Shooting, Communicating, Sustaining, Survivability
 - ➔ ECC Responsible for Planning, Coordinating and Executing Full Spectrum Effects

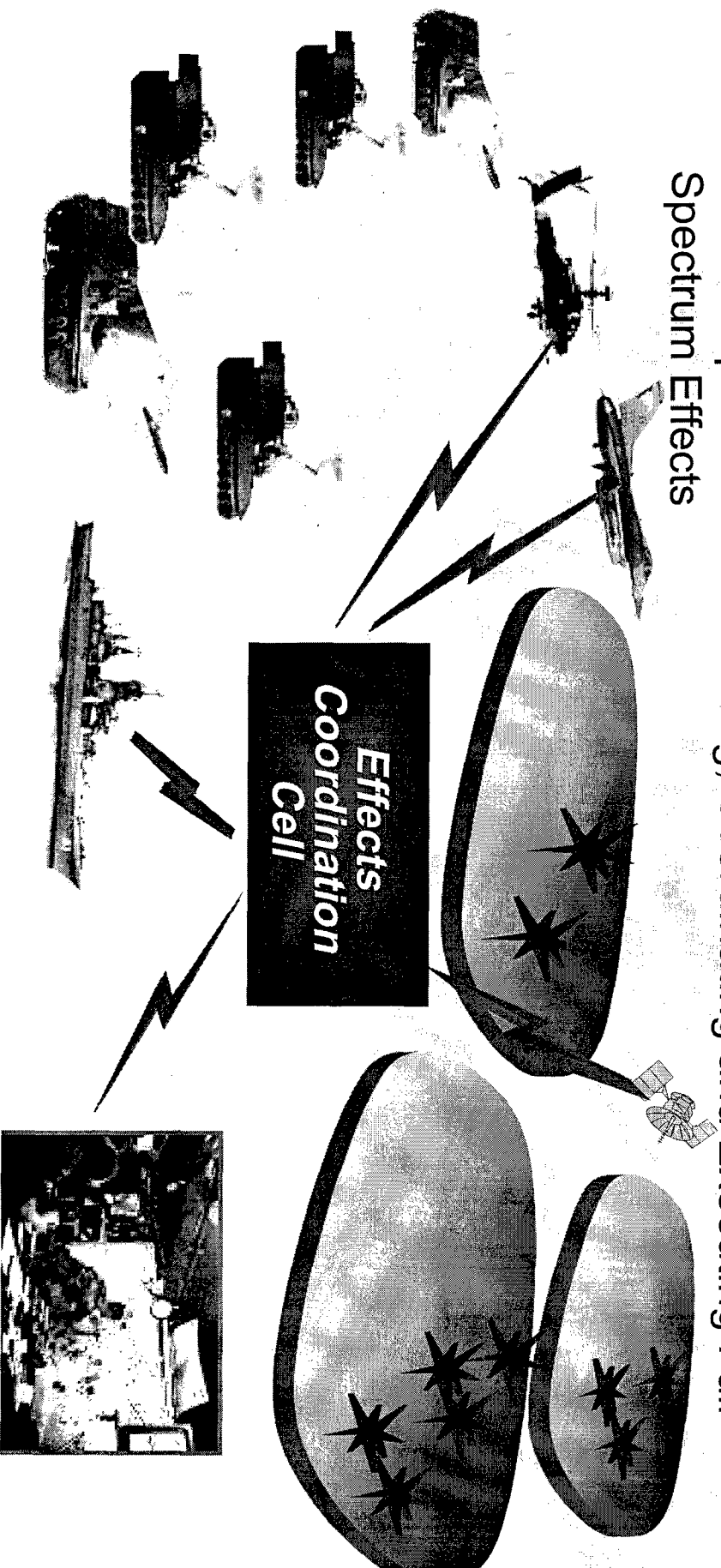

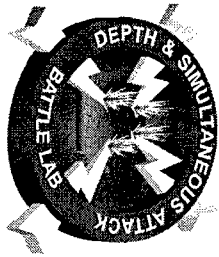

Organizational Transformation

- ✓ Create Modularity, Agility and Flexibility Through
 - ➔ Unitary Battalion and Battery HHS TOE Designs
 - ➔ Composite Cannon and Rocket BNs
 - ➔ Create an Effects Coordination Cell

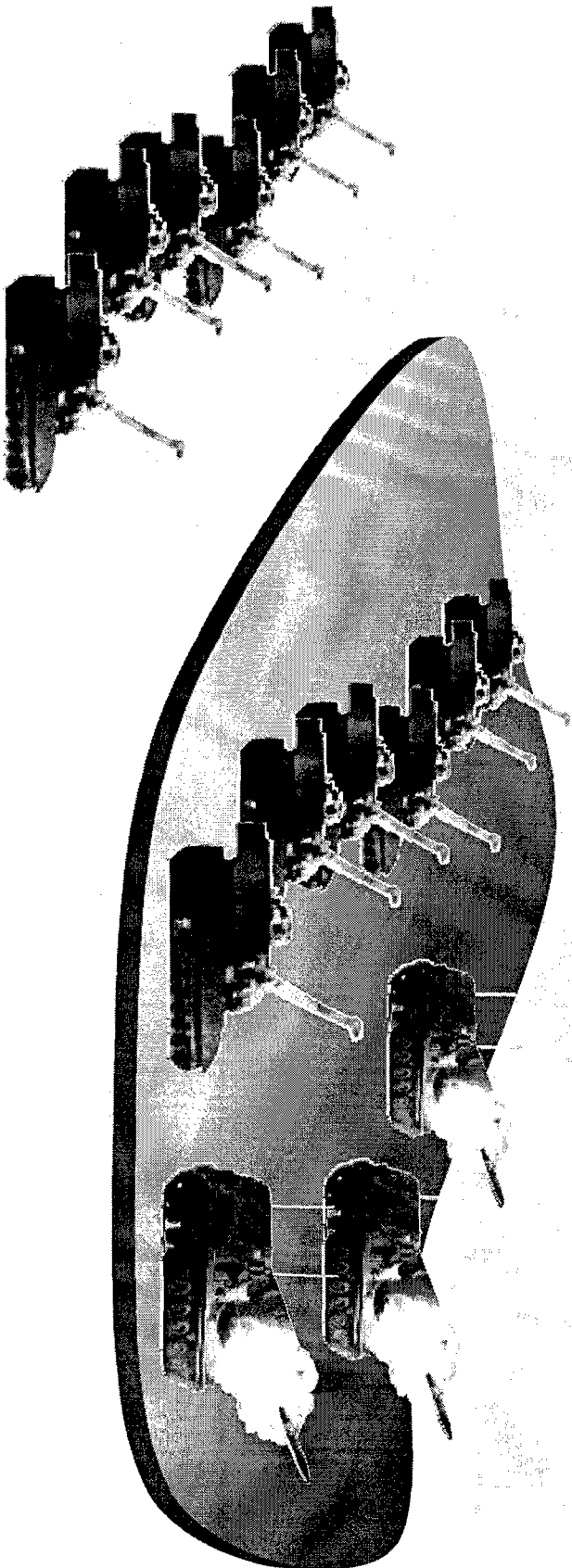

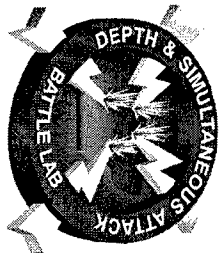

Dynamic Force Tailoring

- ➔ Allocate Effects Instead of Allocating Platforms to Maneuver Forces
- ➔ Centrally Pool Resources at the Highest Tactical Level
- ➔ Mission Tailored Organizations -- Multiple Platforms

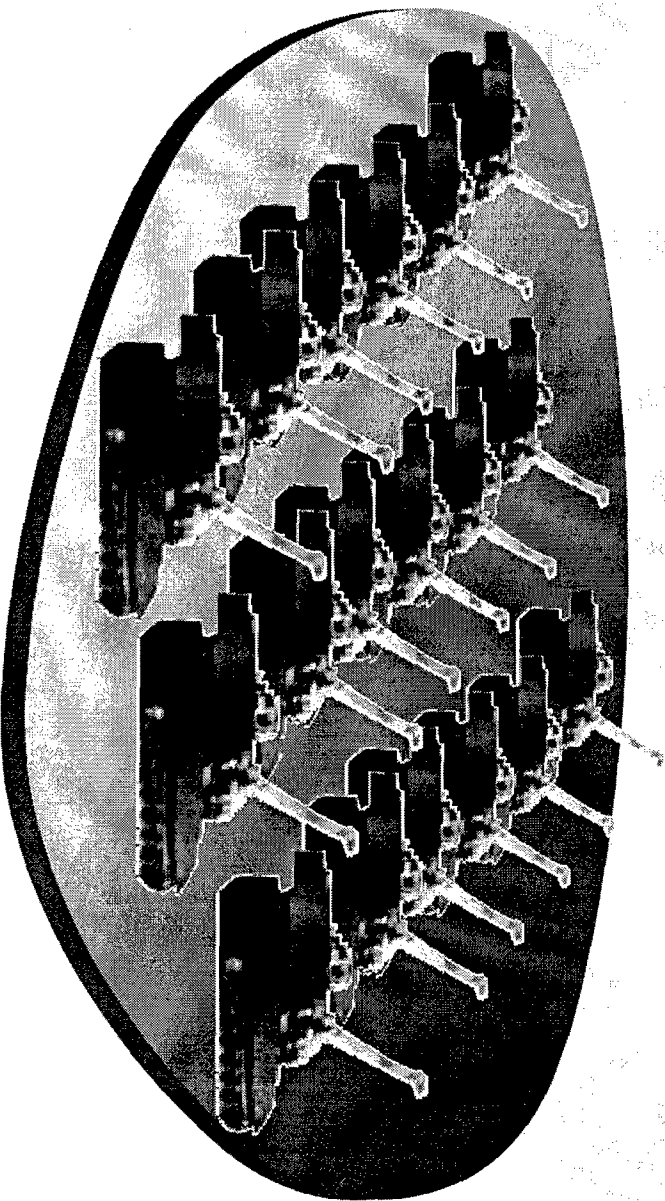
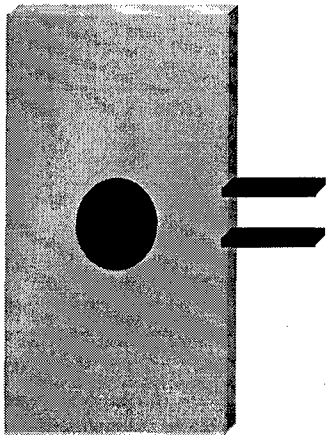

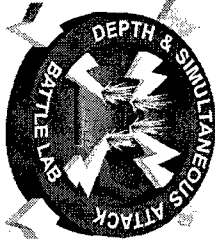

Munitions Centrality

- ✓ Powered, Guided, Precision, Loitering FXXI Munitions Shift the Requirements for Accurate Predicted Fire to the Munitions.
- ✓ Requirement for Both Lethal and Non-lethal Munitions
 - ➔ Massed and Precision Lethal Systems
 - ➔ Non-lethal Spectrum Includes Sensors, Incapacitating Agents
 - ➔ Stunning/jamming, Obscurants and Illumination Devices



Mission

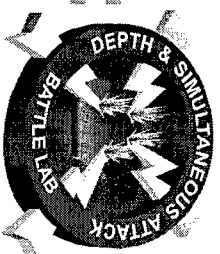

Ensure That Future Generations of Soldiers and Leaders Have the Same Battlefield Edge We Had In Desert Storm

Established in 1992, Battle Labs Strive to Maintain the Army's Battlefield Edge

**Look for New Ideas, Concepts, and Technologies
Explore Innovations From Industry and Academia
Experiment With:**

How We Fight

Our Training

Future Leader Development

Army Organizations

Doctrine

Equipment

The Soldier's Environment

Organization

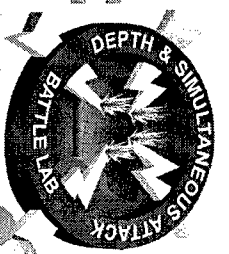

ARL Field Office
 • 5
 Attach LNOs
 • 1 ARDEC
 • 1 CECOM
 • 1 NAVY

BL Structure
 • 10 OFF
 • 2 ENL
 • 4 CIV
 • 4 Contractors
 20 total

Admin / Ops

- Personnel Mngmt
- Security
- Distribution
- Travel
- Budget
- Supply
- Graphic Support

Sims Structure
 • 1 OFF
 • 1 WO
 • 3 ENL
 • 10 CIV
 • 12 Contractors
 27 total

Science & Technology Branch

- R&T PROCESS**
- STO
 - ACT II
 - CEP
 - ATD (Formulation)
 - ACTD (Formulation)

Experiments and Demonstrations

- AWE
- BLE
- ACTD
- Doctrinal Expertise

Simulations

- Sims Support to
 - BLWE
 - AWE
 - ATD
 - ACTD
- Classroom XXI
- JANUS/BBS Facility
- Modeling Support

Advanced Fire Support System

A Future Effects Delivery System

AFSS - A DARPA Program...

Objective: Design, Development and Demonstration of an **Affordable, Containerized, Platform Independent, Indirect Fire Weapon Systems Capable of Performing a Variety of Missions**

Contractors: Lockheed Martin, Raytheon

Schedule:

- ✓ Jan 98 - Nov 98 **Concept Definition**
- Feb 99 - Jan 00 **Option 1 -- Detailed Design Component Demo and Risk Mitigation for BOTH Loiter Attack and Short Range Ground Attack Missile**
- Jan 00 - Jul 02 **Option 2 -- Fabrication and Demonstration of AFSS**

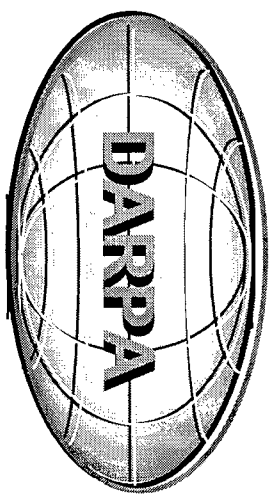

Partnered With a Dynamic AFSS Team

The AFSS Team...

For a Multi Battle-Dynamic Weapon System

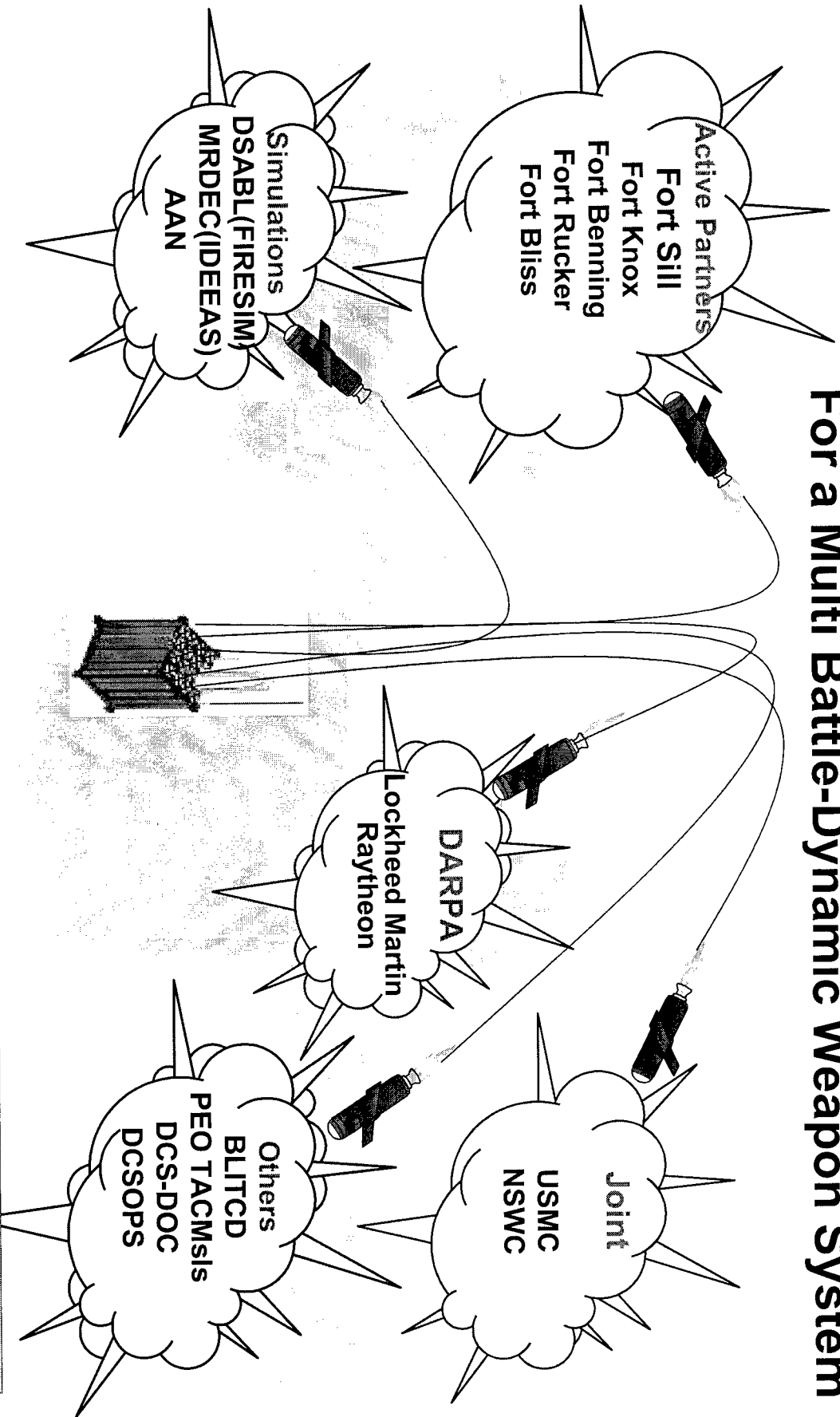

IPR #1 Conducted at Fort Sill 10-11 February; Over 45 Attendees

CRUSAIDER

The ARMY XXXI Firepower Revolution

Presented to:

NDIA Fuze Conference

7 April 1999

Presented by:

MAJ Stephen Hitz

TSM-Cannon Office

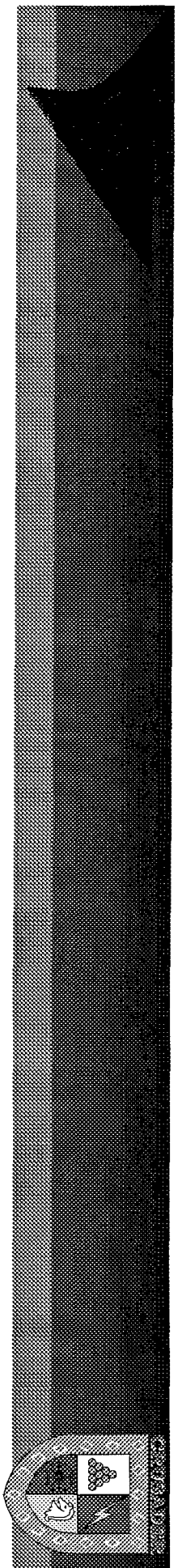

... a howitzer and resupply vehicle with ...

- A state-of-the-art cockpit with embedded command and control that lets the crew fight the system to its max potential,
- A robust cannon that doesn't overheat and produces a tremendous rate of fire,
- A reliable ammo handling system that does not jam and keeps the projos coming,
- A powerful powertrain that keeps the artillery up with the maneuver forces,
- A suite of survivability features that protects the soldier and the system.

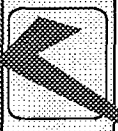
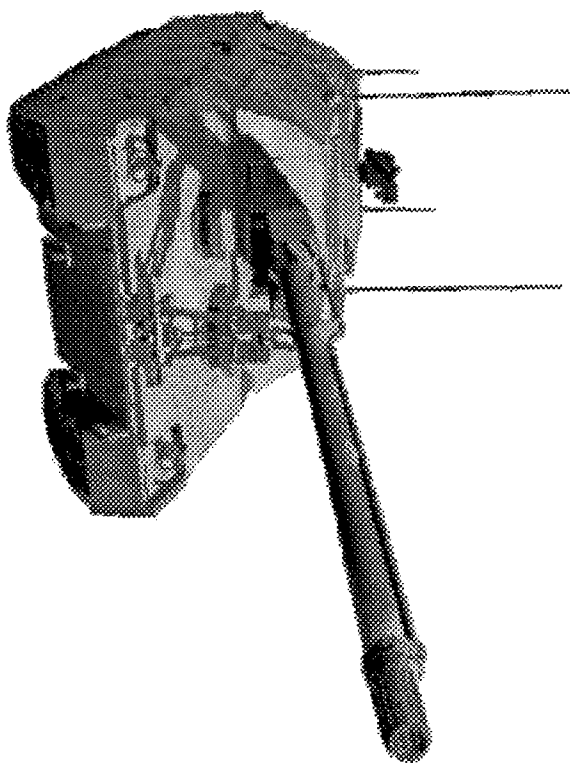

No Other Howitzer in the World Can Do All of These!!!

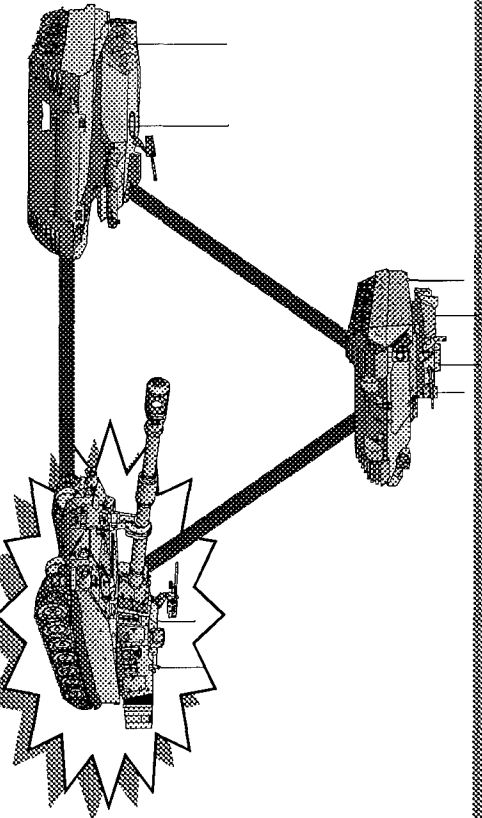
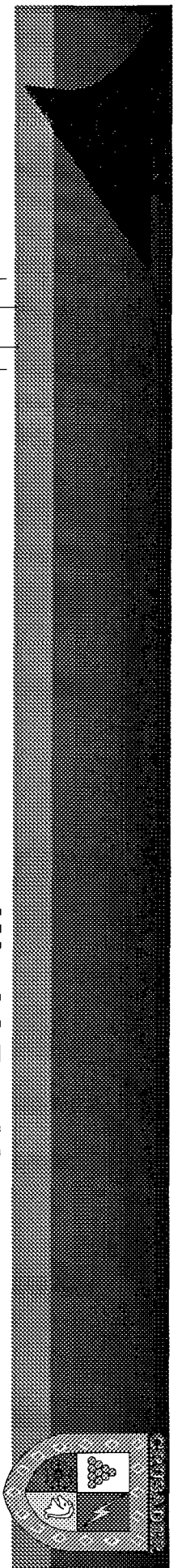

1950's Design, Built in 60's, 6 Upgrades
Over 30 Years . . . MAXED OUT!

**... U.S. Is Out Gunned
By Several Systems
Currently Fielded or in
Production!**

World Rankings:

- #1 Tank - M1
- #1 IFV - Bradley
- #1 Helicopter - Apache
- #5 SPH - Paladin

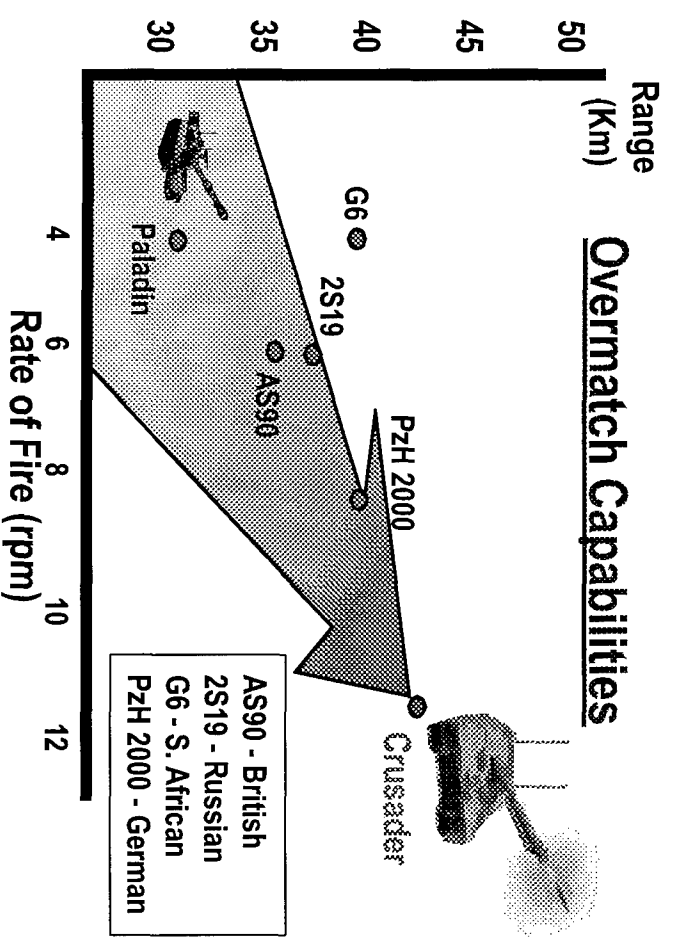

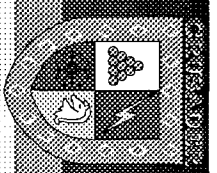

Mission

Provide Responsive and Accurate Fires

- 24 Hours a Day
- In All Weather
- Over All Terrain

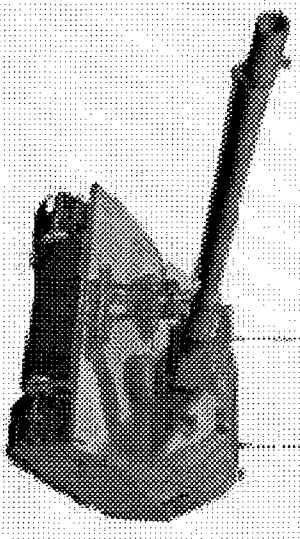

Self-Propelled Howitzer (SPH)

Requirements

- RANGE: 40-50 Km
- Max Rate of Fire:
10-12 Rds/Min

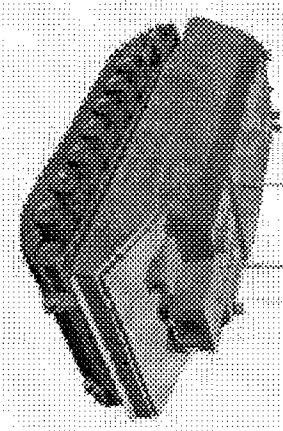

Resupply Vehicle (RSV)

Requirements

- Payload: 130-200 Rds
- Rearm Howitzer: 12 Mins

System Requirements

- Mobility Equal to Maneuver Systems
- Crew: 3-Man



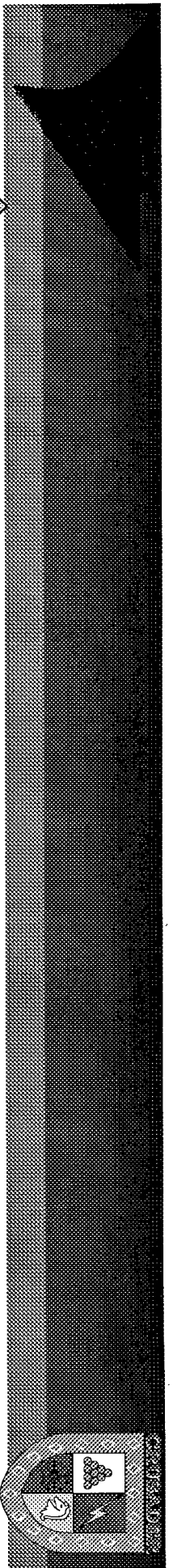

489%
Improvement in Accuracy

77%
Increase in X-Country Mobility

33%
Reduction in Crew Size

Max Rate of Fire (RPM)	4 (for 3 min)	10-12
Sustained ROF	1	Same as Max
Range	30 Km	40-50 Km
Accuracy (CEP at 25 Km)	155 M	80 M
One Gun TOT	1 Rd	4-8 Rds
System Capacity	129 Rds	190 Rds
Ballistic Protection	Frag	DPICM
Other Protection	None	Classified
Situation Awareness	None	Automated
Force Comparability	M60A3	M1/M2
Horsepower	440	1500
Cross-Country Speed	27 KPH	48 KPH
90 Sec Dash to Cover	560M	750M
Crewman	5 + 4	3+3

250%
Increase in Rate of Fire

66%
Increase in Range

300%
Improvement in Resupply

25%
Reduction in Ownership Costs

47%
Increase in Ammo Capacity

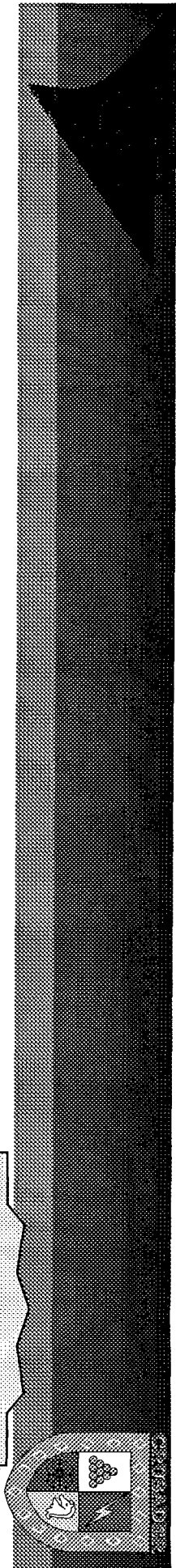

Joint Forced Entry

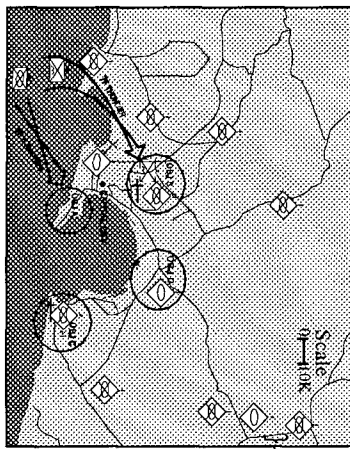

31% Greater FE
15% Fewer Casualties

Pre-Positioned Force

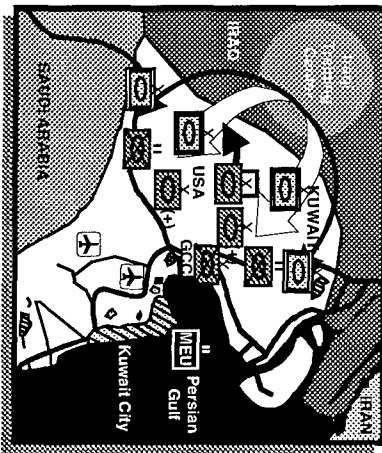

16% Greater FE
3X More Kills
18% Fewer Casualties

Major Theater Warfare

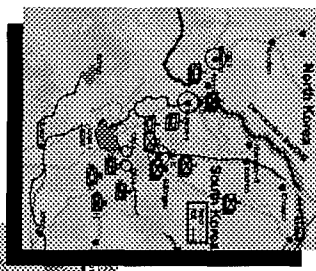

NEA-65% Greater FE
30% Fewer Casualties
SWA-48% Greater FE
30% Fewer Casualties

EARLY ENTRY OPERATIONS

DECISIVE FORCE OPERATIONS

Greater Lethality, Fewer Casualties

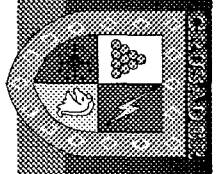

Key Technologies

- ❖ Reconfigurable Crew Stations
- ❖ Digital Flat Panel Displays
- ❖ Vision Enhancement
- ❖ Digital Maps
- ❖ Real Time Situational Awareness
- ❖ Integrated Electronic Technical Manuals
- ❖ Prognostics/Diagnostics
- ❖ Decision Aids

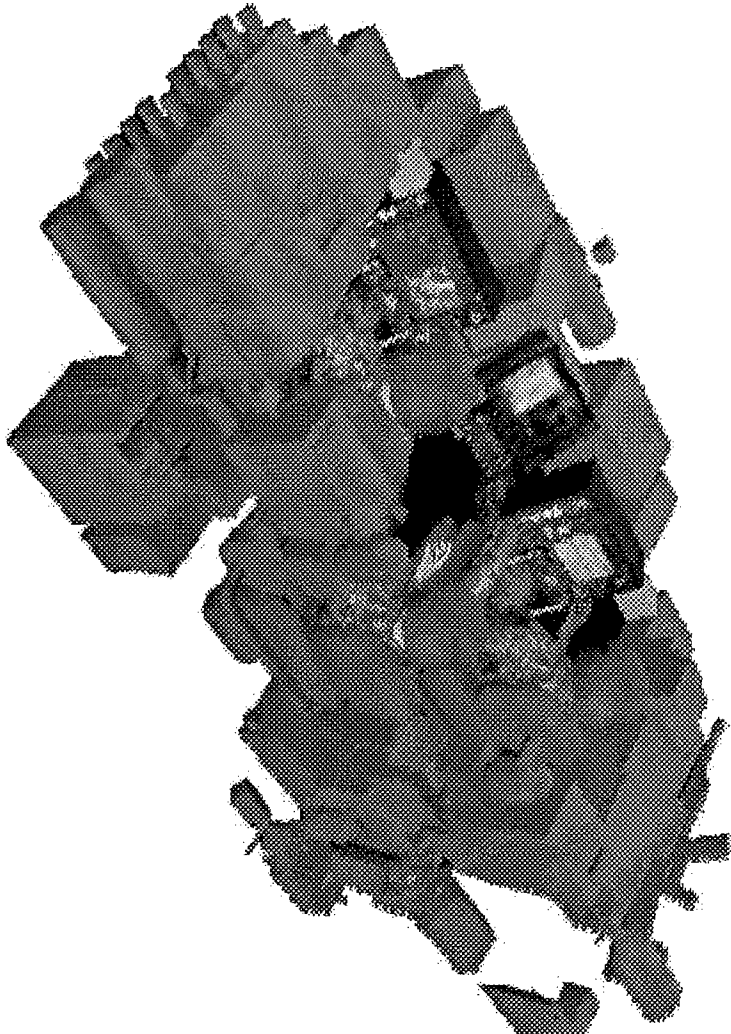

Requirements

- ❖ 3 Man Digital Command Center
- ❖ Interface with Army Battlefield Command System
- ❖ Embedded Battle Command Compliant
- ❖ Communication via Tactical Internet

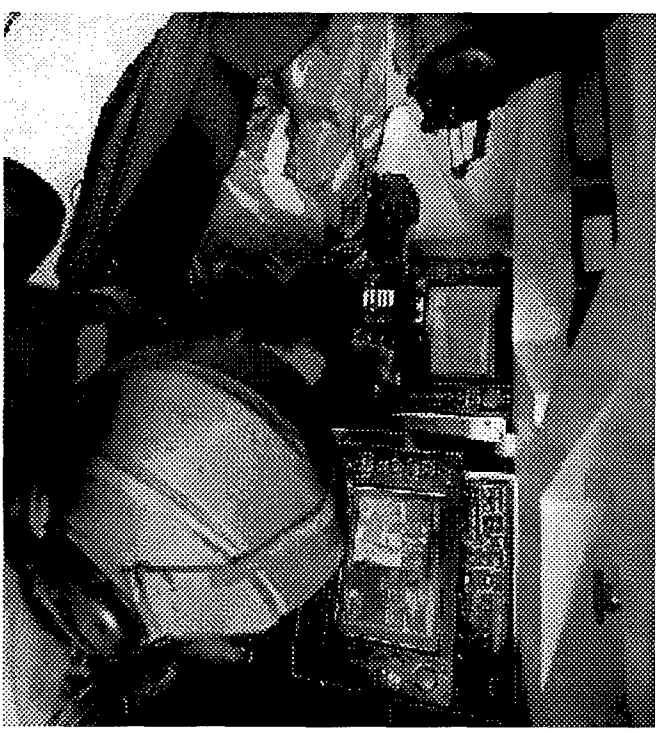

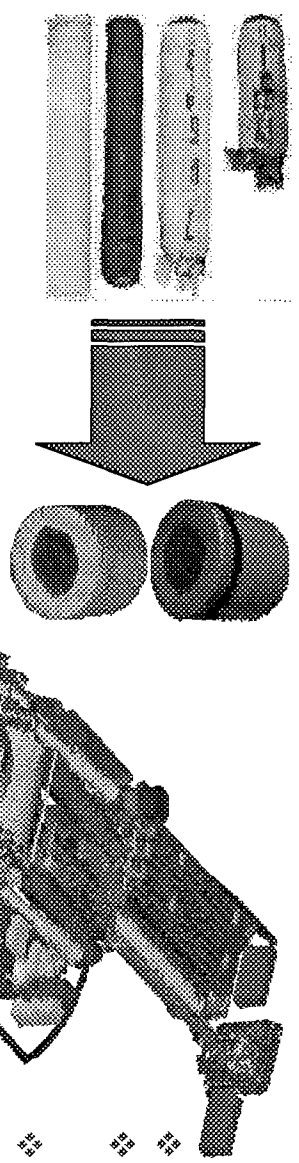
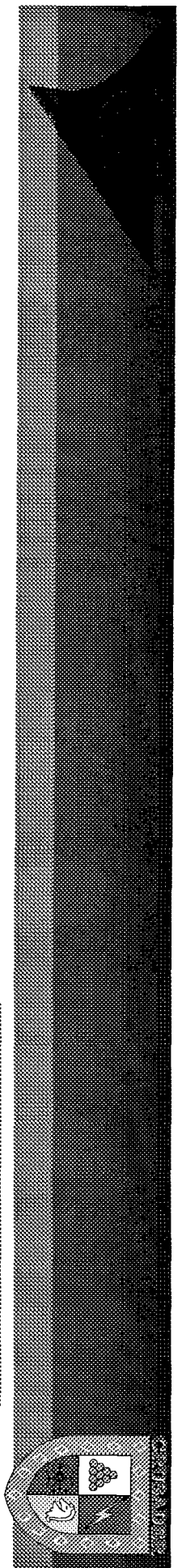

Requirements

- ❖ Maximum Rate of Fire: 10-12 Rounds/Min
- ❖ Maximum Range: 40-50 Km
- ❖ Minimum Range: 4-6 Km
- ❖ Multiple Round Simultaneous Impact: 4-8 Round Impact Within 4 Sec
- ❖ Between 5-30 Km

Key Technologies

- ❖ Automatic Loading
- ❖ Active Thermal Cooling - Currently Only One in the World!
- ❖ Laser Charge Ignition
- ❖ Inductive Fuzing-MOFA
- ❖ Projectile Tracking System
- ❖ Modular Artillery Charge System-MACS

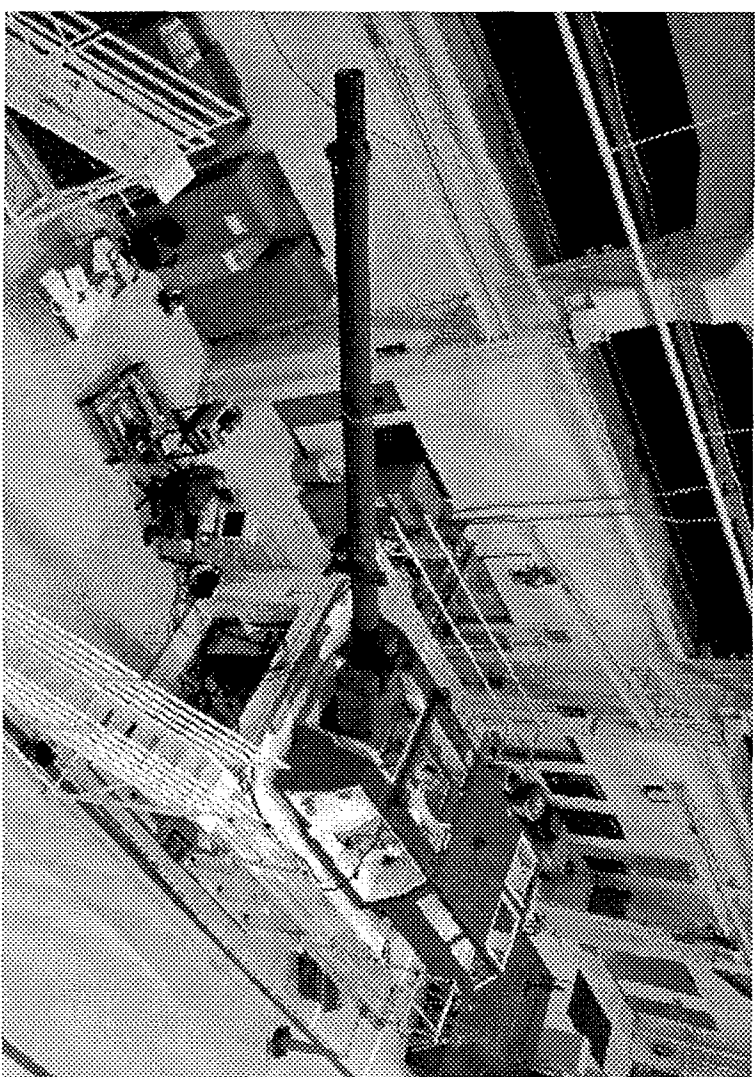

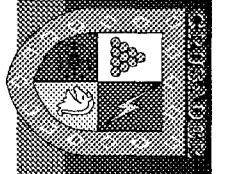

Proximity

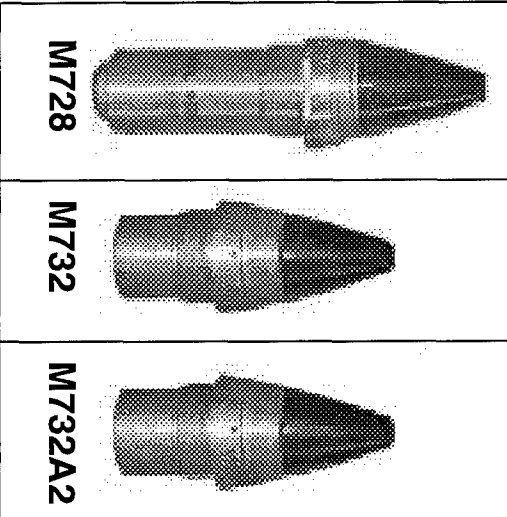

Point Detonating

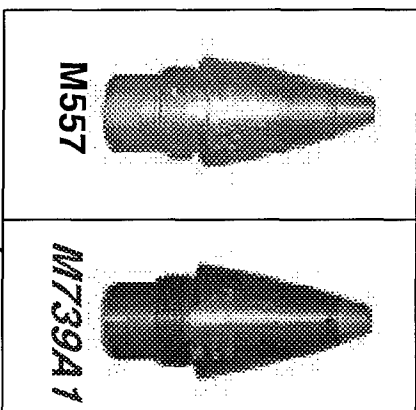

Time

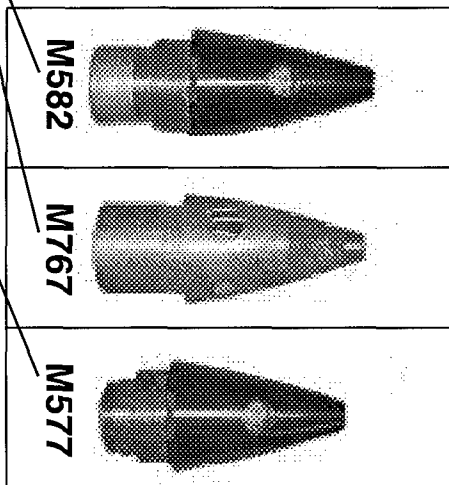

MOUT

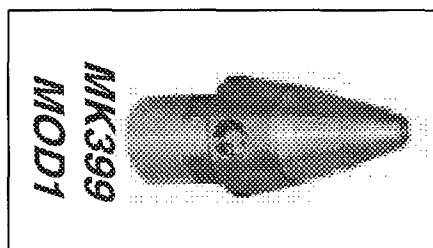

MOFA

- ❖ Four Function Settings
- ❖ Compatible w/105 & 155mm Systems
- ❖ IOC - 1FY00

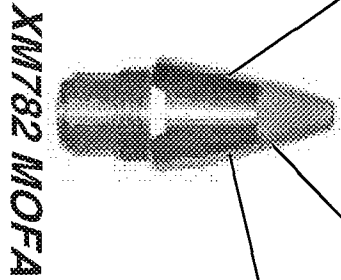

XM782 MOFA

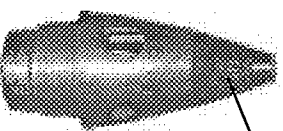

M762 ET

Inductively Set

Reduced Logistics
 Four Fuze Family
 Limits Fuze-Projectile
 Combinations

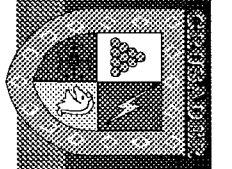

CURRENT CHARGES



M3A1 (Green Bag)



M4A2 (White Bag)

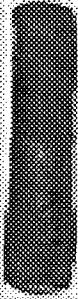

M119A2 (Red Bag)



M203A1

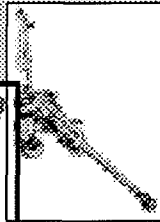

TOWED

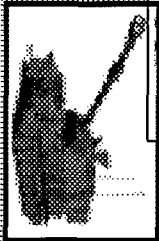

PALADIN

- ❖ Optimized for Crusader
- ❖ Compatible With All 155mm Systems
- ❖ Automated Handling Compatible
- ❖ Bi-Directional Increments
- ❖ No-Excess Propellant
- ❖ 40% Volume Reduction
- ❖ Cost Savings for Training & Operations
- ❖ Enter Production in FY2000

MAACS

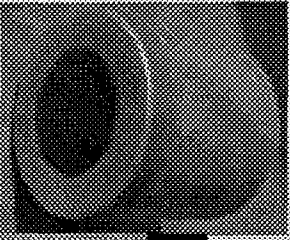

XM231



XM232

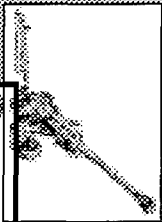

TOWED

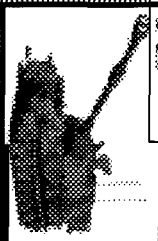

PALADIN



CRUSADER

**Soldier
and
System
Friendly**

XM982

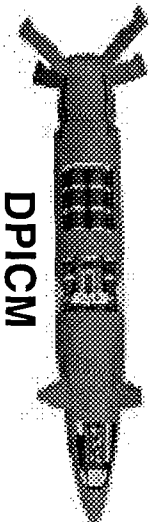
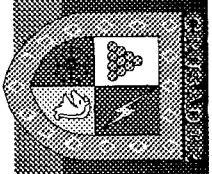

DPICM



SADARM

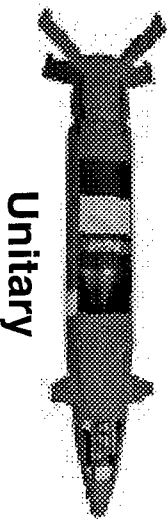

Unitary

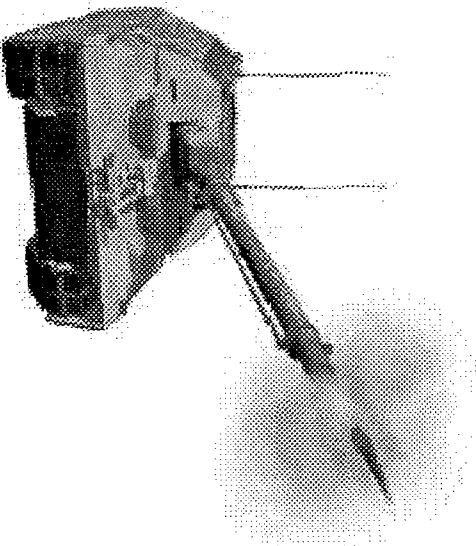

- Family of Fire & Forget GPS/IMU Guided Projectiles
- Compatible with all 155mm Howitzers
- Precision Accuracy (20 m CEP) Independent of Range
- Paladin M198/JLW155: 6 to 37Km
- Crusader: 6 to 47 Km
- Single Projectile Design Accommodates Multiple Payloads

+	DPICM	-	FX966
+	SADARM	-	FX967
+	Unitary Warhead	-	FX968

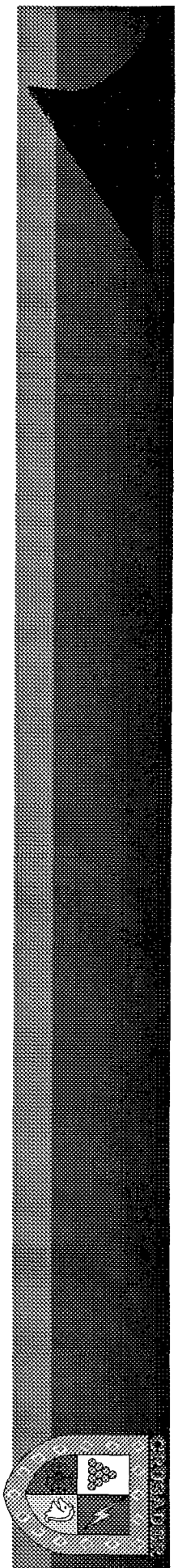

Key Technologies

- ❖ Automated Inventory Management
- ❖ Transfer: Projectile, Propellant, Fuel and Data
- ❖ Automatic Recognition (Projectile ID and Modular Artillery Charge System)
- ❖ Automatic Docking/transfer

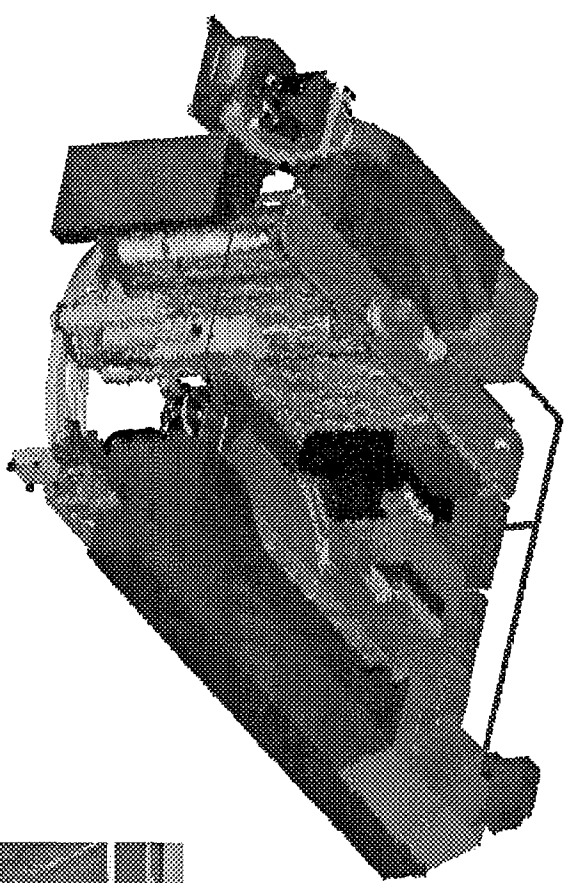

Requirements

- ❖ Load and Fire Cycle: 5 Sec
- ❖ Howitzer Rearm/Refuel: 12 Minutes
- ❖ Fuel Transfer Rate: 65 Liters/min
- ❖ Upload Resupply Vehicle: 65 Minutes

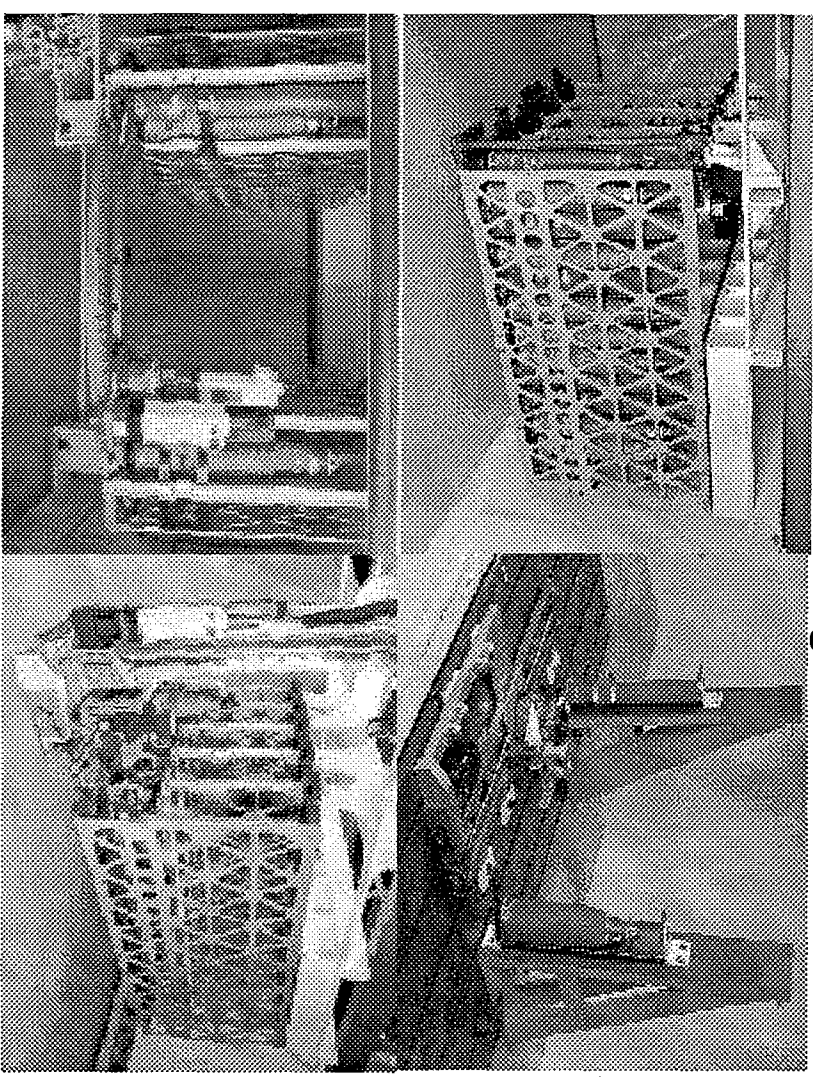

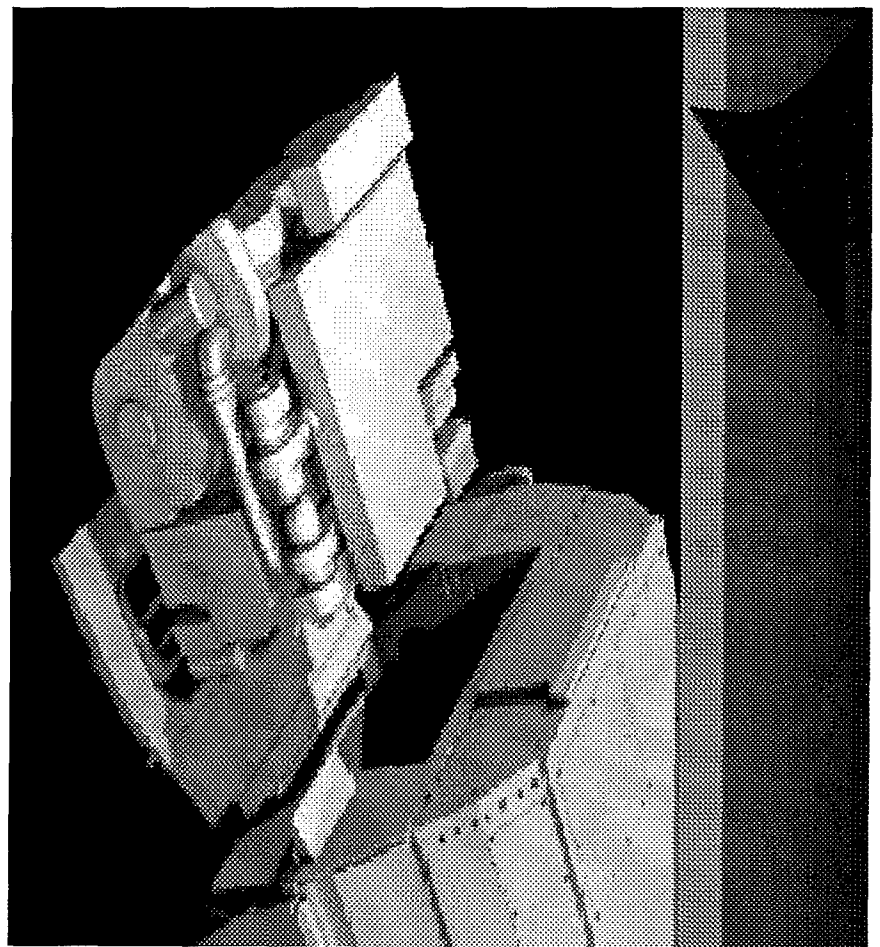
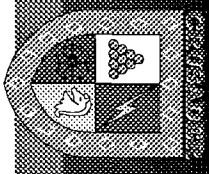

Requirements

- ❖ Highway Speed: 67-78 Km/hour
- ❖ Cross Country Speed: 39-48 Km/hour
- ❖ Execute a Survivability Move: 750 Meters in 90 Seconds
- ❖ Operate at Temperatures Between -51°F and +120°F

Key Technologies

- ❖ 1500 Horsepower
- ❖ Variable Geometry Turbochargers
- ❖ Self Cleaning Air Filter
- ❖ Roll In / Roll Out Power Pack
- ❖ External Hydropneumatic Suspension
- ❖ Drive-by-wire

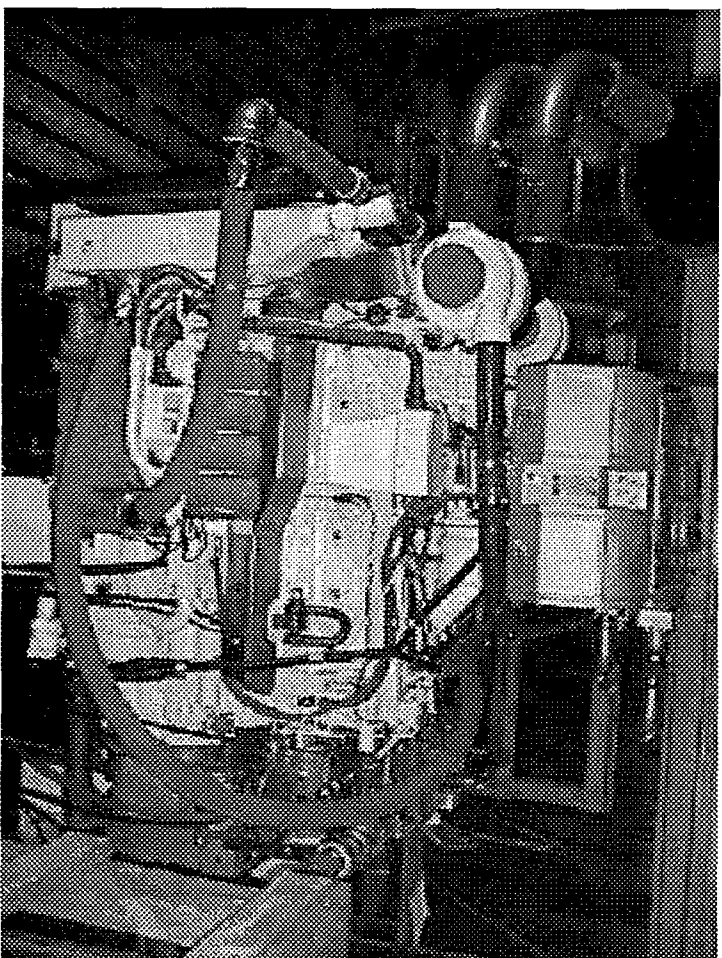

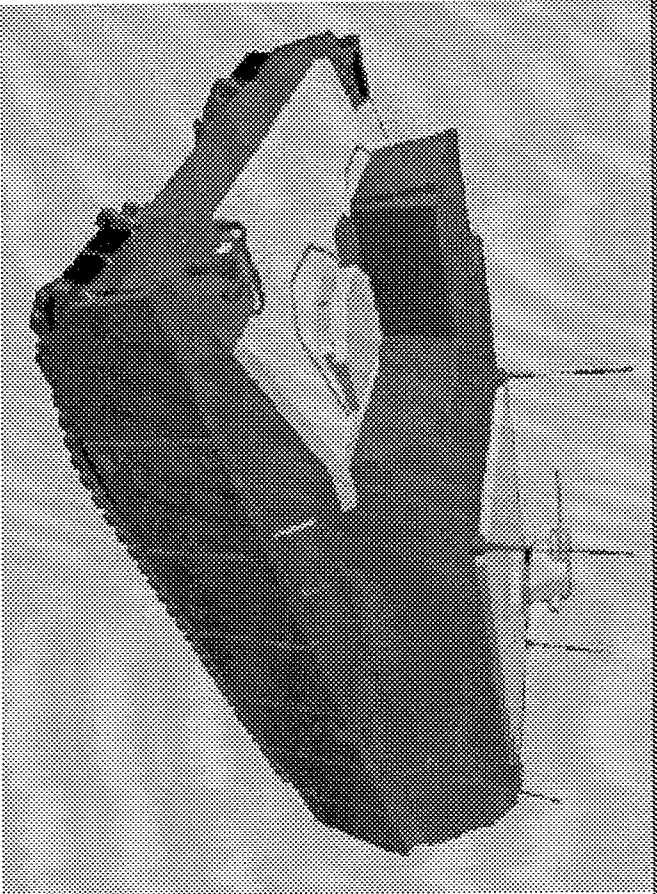
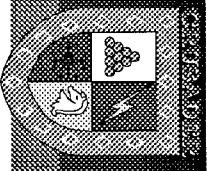

Requirements

- ❖ Soldier Survivability
- ❖ Ballistic Protection
- ❖ Non-Ballistic Protection
- ❖ Defensive Fires w/Target Acquisition
- ❖ Auto Fire Suppression

Key Technologies

- ❖ Integrated Composite Armor
- ❖ Crusader/Advanced Amphibious Assault Vehicle - 2519 Aluminum
- ❖ Detection Avoidance
- ❖ All Electric - No Hydraulics
- ❖ Environmental Control
- ❖ Remote Controlled Weapon Station
- ❖ Active Defense System - Product Improvement

Unparalleled Protection for Crew

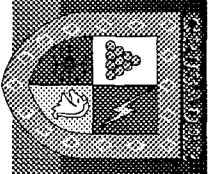

Continuous Improvement (Spiral Development)

- Active Protection
- Electrochemical Cannon
- Advanced Materials for Hull/Turret
- Advanced Powerpack
- Smaller, Lighter, Improved Fuel Efficiency
- Enhanced C3I
- Improved Sustainability

M 2001A1

M 2001A2

Technology Transfer To Other Systems

- Crew Cockpit
- Real Time Common Operation System
- New Composite Armor
- Simulation Based Acquisition
- Real Time Electronics
- Robotics
- Hit Detection Avoidance
- Prognostic/Diagnostic
- Suspension and Track

Future Scout

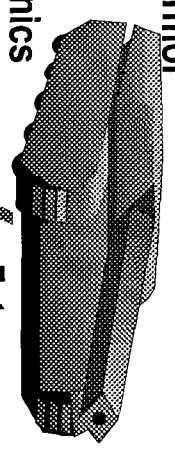

Future Combat Vehicle

Technology Transfer

From Other Systems 2020-25

Grusader - The Army Ground Technology Carrier

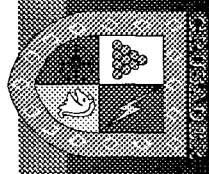

**Crusader is a Revolution in Tactical Fires;
Nothing like it in the World . . . FILLS the VOID**

**Crusader - Essential for Army XXI and AAN . . .
MEETS URGENT WARFIGHTER'S NEEDS**

Only Crusader Provides...

Survivable, Lethal, Mobile, Responsive, Long Range Fire Support Capability

Critical Responsiveness for Warfighters

State of the Art Technology

First U.S. Artillery Overmatch Since WWII

Robust Range of Options

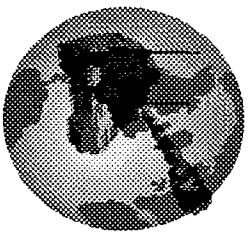

World's Leader . . .

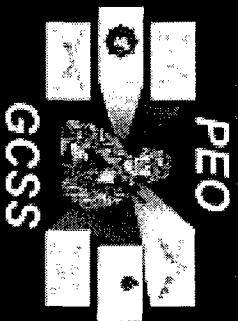

**Fuzing For "DIRECT FIRE"
Applications
43rd Annual Fuze Conference**

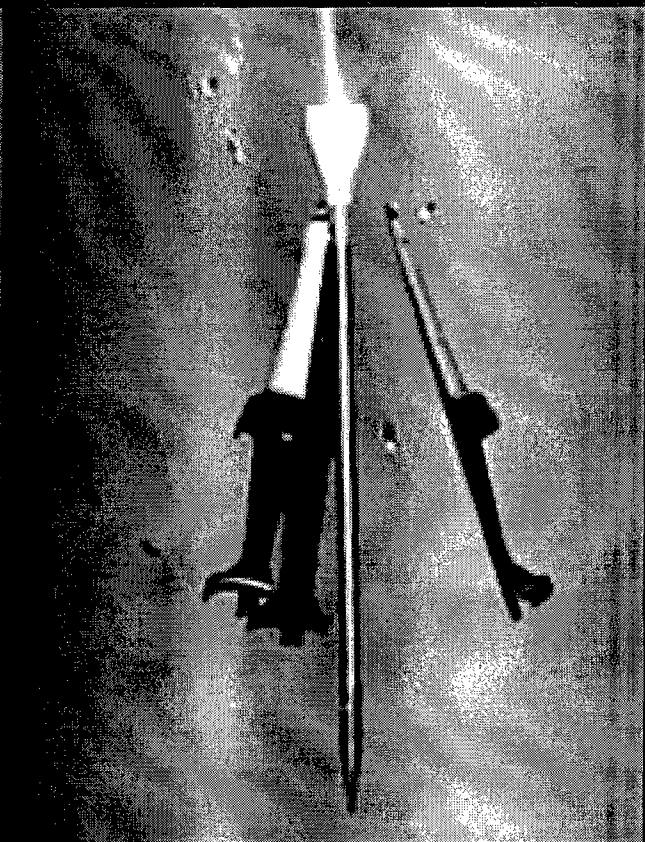

7 APRIL 1999

COL Raymond Pawlicki

**Project Manager-Tank and Medium caliber Armament Systems
Program Executive Office-Ground Combat & Support Systems
Picatinny Arsenal, N.J.**

PM-TMIAS Focus

- ◆ Life Cycle Management of Ground Combat Direct Fire Armament Development
- ◆ Conduct International Cooperative Direct Fire Armament Programs
- ◆ Monitor & Influence Direct Fire Armament Technology Base



Ammunition Development



International Cooperative Development

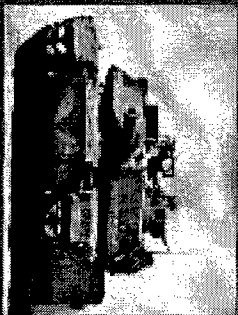

Armament System Development

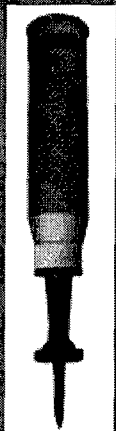

Production & Fielding

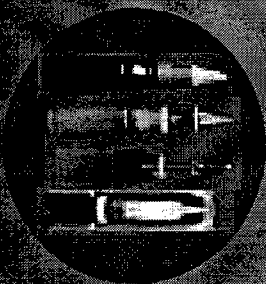

Automatic Cannon Caliber

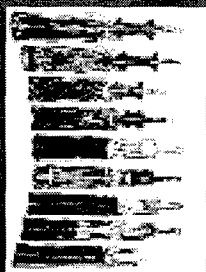

Life Cycle Sustainment

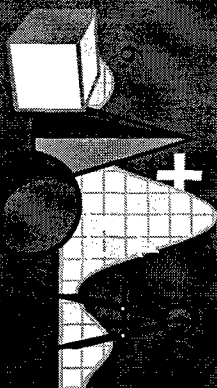

Tech Base

Vision - Goals

**Develop and Demonstrate Low Cost,
Compact, High Performance Fuze
Technologies to Optimize Warhead
Performance and Increase Lethality for
Tank and Medium Caliber Weapon
Systems**

Customer Gun System Requirements

Combat Vehicles

- Acquisition Approach; “NDI”
- Anti-Personnel
 - Prone Defilade Troops
 - Foxholes
- ATGM Sites/Bunkers etc. Lt. Trucks
- IFV’s
 - BMP 3 and Beyond
- Self Air Defense



Market Assessment

- Combat Vehicles
 - USMC AAV (Approx 1000 Vehicles)
 - IOC FY06
 - Future Scout Cavalry System (Approx. 1600 vehicles)
 - ATD FY98-01
 - EMD FY02-06
 - Future Infantry Vehicle (Approx. 1600 vehicles)
 - EMD FY12
 - Bradley Upgun
 - No Current Plans
 - FCV
 - Strike Force

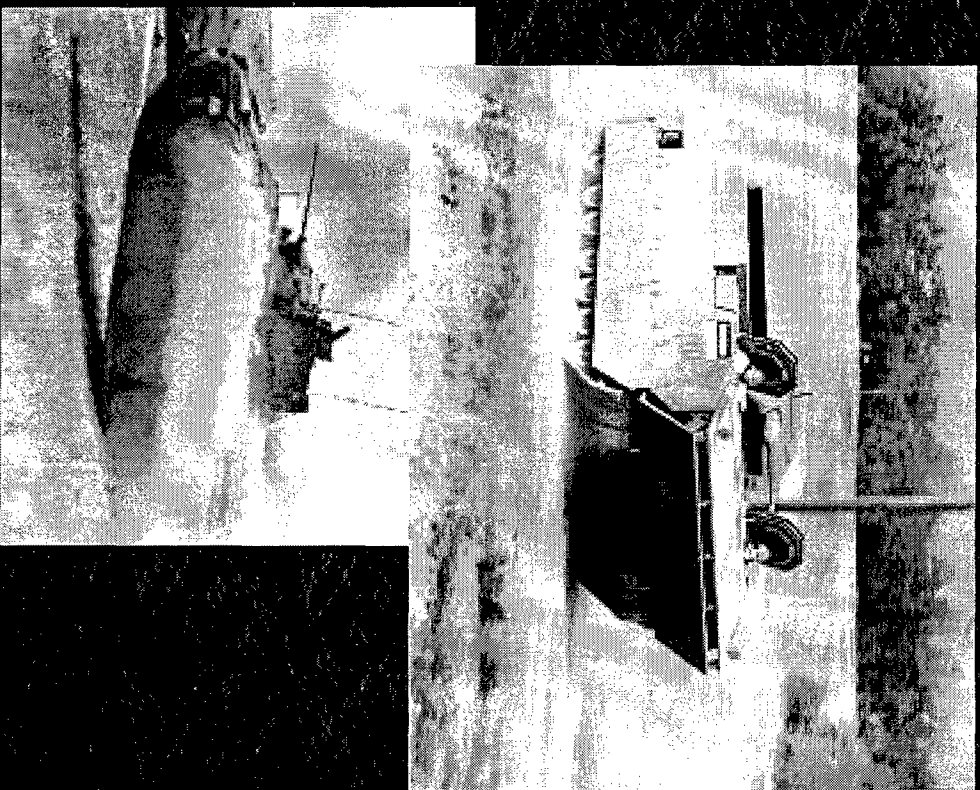

FIV Armament Requirements

- **Direct Fire Support for Dismounted Infantry**
- **Kill/Neutralize ATGM, DEW & Crew Served Weapons**
- **Anti-Tank Kill Capability On-The-Move**
- **360-Degree Small Arms Capability**
- **Dual Gun & Missile Engagements**
- **Defeat Helicopters**
- **Auto-Detect, Recognition, and Identification**
- **Defeat Enemy in Buildings & Bunkers**
- **All Weather Target Detection**
- **Non-Lethal Close-In Offense and Defense**

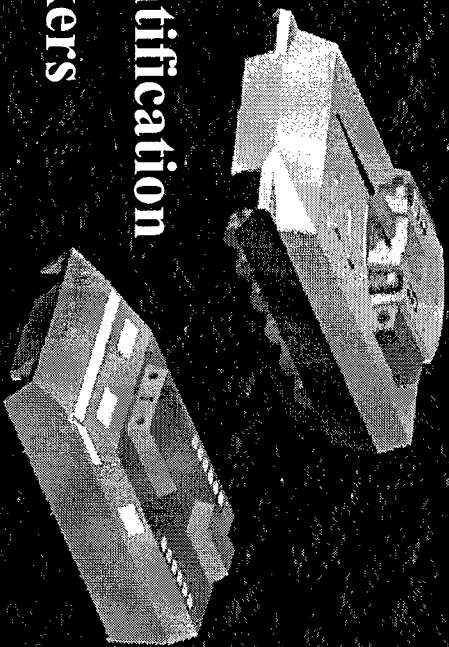

FCS

Two Families of Vehicles

Fighting Vehicles 22 - 27T
(with Modular Armor)

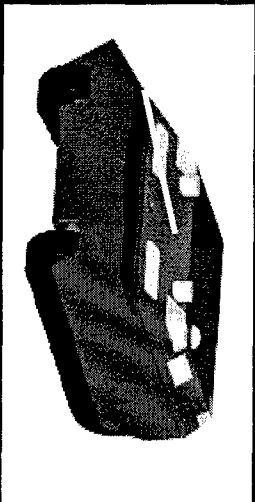

Variants (FSCS-based)

- FSCS
- FCV
- Unmanned Missile Carrier
- Infantry Carrier

Carrying Vehicles 15 - 20T

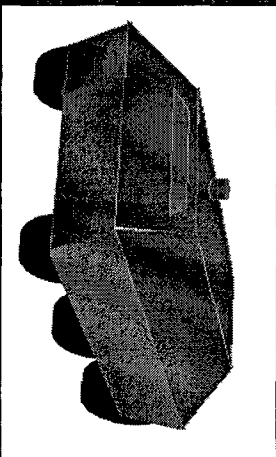

Variants (New Chassis)

- FIV
- 120mm Mortar Carrier
- C2 Vehicle
- Fire Support
 - LONGFOG or MLRS
 - Towed Ultralight 155mm
 - Can Carry Missile in a Box
- Air Defense Linebacker (Stinger)

(Large Numbers)

Advanced Light Armament for Combat Vehicles (FY01-03)

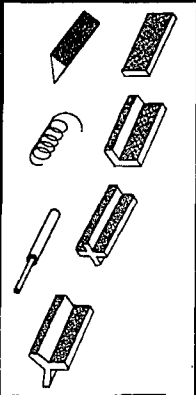

KE Rods
Material
Novel Penetrators



Bursting Munitions

OCSW/OICW
European Candidates

Goals:
Demonstrate
Enhanced
Anti-Armor/
Personnel Effects
to Meet Multiple
User Lethality
Requirements

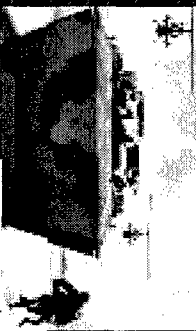
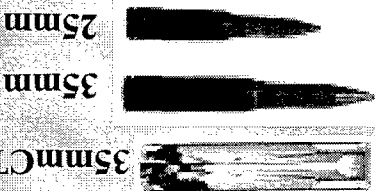

- FSCS
- Bradley
- FIV
- AAVV

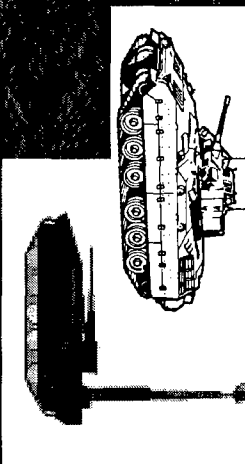

Providing Enhanced
Anti-Armor/Personnel
Effects for Ground Combat
Vehicles

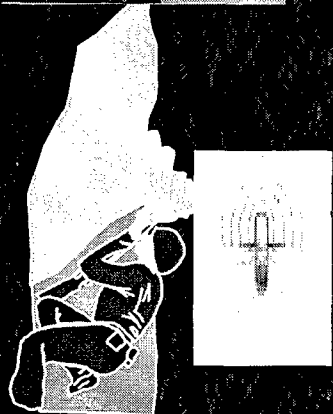

**Leveraging On-Going Technologies
For Future Combat Vehicle Needs**

Summary of Autocannon Candidates

- 25 mm M242
 - In Production for Bradley
 - AP Performance Maximized
 - HE Growth: Bursting Munition
- 30 mm Bushmaster II
 - FMS to Norway
 - GAU-Type Ammo
 - Selected for AAVV Prototype
 - Growth to 40mm Supershot
- 35 mm Bushmaster III
 - Prototype Cannon
 - Gun Fits Bradley A2
 - Good Performance (Current & Projected Threats)
 - Growth to 50-mm Supershot
- 40 mm CT-2000
 - 1st Gun Prototype Spr. 97
 - Gun/Feeder Fits Bradley A2
 - Mann Barrel Demo Dec.97
- 40 mm Bofors L70/B
 - In Production for CV90
 - Cumbersome (21-inch long) Ammunition
 - Ammo Performance Only Marginally Better Than 35 mm
- 45 mm CT-2000
 - Prototype Cannon
 - Significantly Larger Size
 - Cased Telescoped Ammo

Variable Timed Fuzing Technologies

- 20mm OICW / 25mm OCCSW
 - Multi-Functional (PD/Timed/Delayed PD)
 - Less Aggressive Launch Environment
- 35mm AHEAD “Time Fuze”
 - In Production for “Skysield”
 - Air Defense Gun System
 - Inductively Set @ Muzzle
- 35mm German Time Fuze
 - Production Ready
 - Inductively Set at Chamber
- 40–45mm CTAI Time Fuze
 - Developing Optimized Fragmentation Warhead
- 40mm Bofors 3P
 - Proximity Fuze

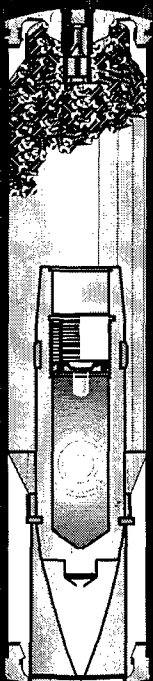
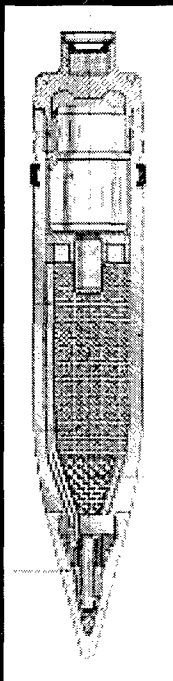
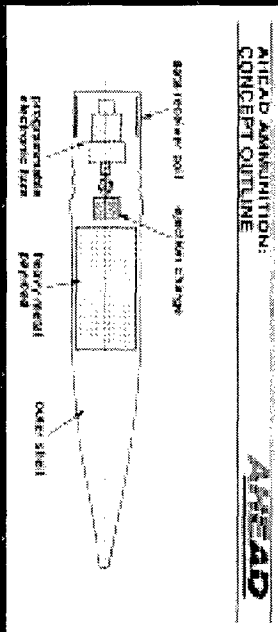

Advanced Light Armament for Combat Vehicles (STO(P))

OBJECTIVE: Demonstrate Advanced Ammunition Related Technologies that Enhance the Lethality of the Future Combat Vehicle Armt., in Terms of Target Defeat and Improved Accuracy for Transition to Follow-On Developmental Programs

- JUSTIFICATION:**
- Maximized Performance from Ammunition Caliber
 - Demonstrated Options for FSCS EMD
 - Develop Advanced Airburst and KE Rounds for Future Combat Vehicles

Advanced KE Material and Sabots
Leverage State-of-the Art
Bursting Munition Technology

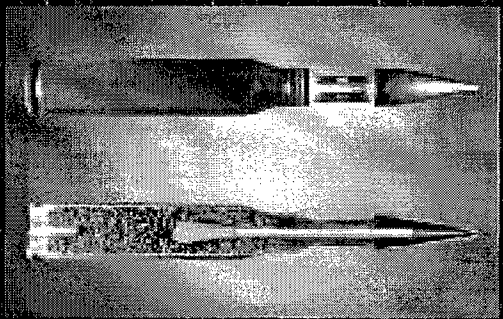
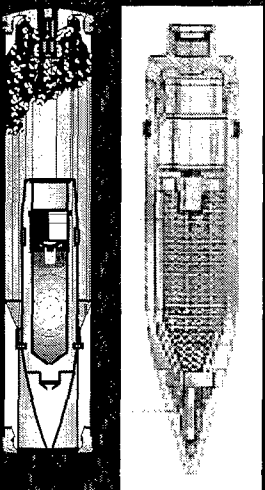

PROGRAM SCHEDULE

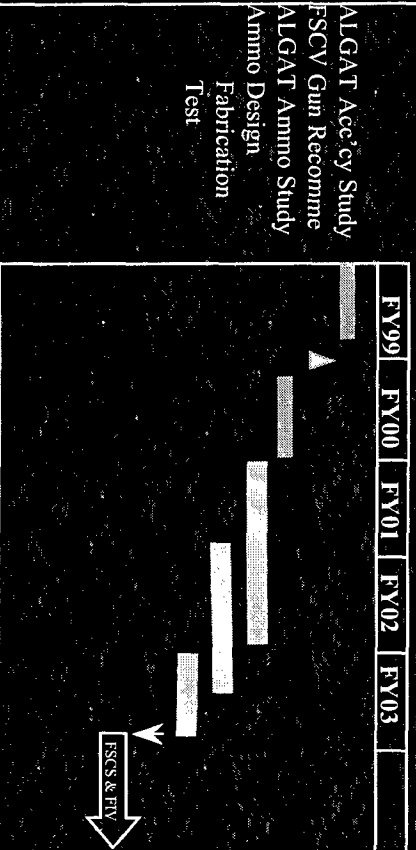

PROGRAM DESCRIPTION:

- Conduct Joint User/Developer Lethality Prioritization Assessment
- Leverage Composite Sabot, Penetrator, and Propulsion Technologies; Maximize Performance without System Degradation
- Demonstrate Enhanced Target Defeat Potential
- Transition Ammunition Designs to Follow-On Development

APPLICATION

- FSCS & FIV Technology Assessments
- Joint FSCS EMD Program
- USMC AAV

Fuze Technology

Driving the Need

- **Performance**
 - **Address Modern/Future Threats**
 - **High Reliability to Assure Lethal Function**
- **Logistics**
 - **Replace Multiple Fuzes in Inventory**
 - **Provide Increased Effectiveness to Reduce Logistics Burden**

Fuze Technology Cont'd

- **Size**
 - **Include Multiple Function Modes**
 - **Miniaturize Electronics for Med Cal**
 - **MEMS Technology**
- **Life-Cycle Cost Burden**
 - **Affordable**
 - **Reduce Devel Cost & Demil Costs**

Fuzing Technology Challenges

- Target Sensors
 - Anti-Helicopter Fuzing
 - Clutter Free
- Advanced Safety And Arming Devices
 - ESA Miniaturization
 - MEMS
 - Miniaturized Electronics
 - COTS

Fuzing Technology Challenges

- **Auto Setting**
 - **Inductive Setting For Medium Cal and Tank Ammo**
- **Power Supplies**
 - **Environmentally Derived Preferable**
 - **Battery Technology**

Target Sensors

- **Electrostatic Sensors**
- **Upgrade M74 Proximity Switch**
- **Advanced Antennas for RF Solutions**
 - **Clutter Free**
 - **Advanced Algorithms**
- **Target Sensors Which can be Adaptable to Medium Cal Munitions**

Auto Setting

- Inductive Set Capability in Both Medium Caliber & Tank Ammo
- Interim Solutions - Tank Ammo
 - Manual Set
 - Low Temp Displays
 - Allows For Setting While Wearing NOMEX Gloves

Power Supplies

- Preferred Approach is for Power to be Derived from Launch Environment
 - Piezoelectric Generators
 - Turboalternators
- Batteries
 - Fast Rise Time Batteries
 - Liquid Reserve Batteries
 - 20 Year Active Batteries

Advanced S&A Devices

- **MEMS - Micro-Electromechanical Systems**
 - Extreme Miniaturization of Fuze S&As
 - Low Cost in Quantity
 - Rapidly Growing Industrial Base
 - Potential to Integrate Into OICW
- **ESA - Electronic Safety and Arming Devices**
 - On-going Efforts to Reduce Cost and Volume
 - Low Energy Fire Set Key to Meeting Goal

How Small Can a Mechanical S&A Get?

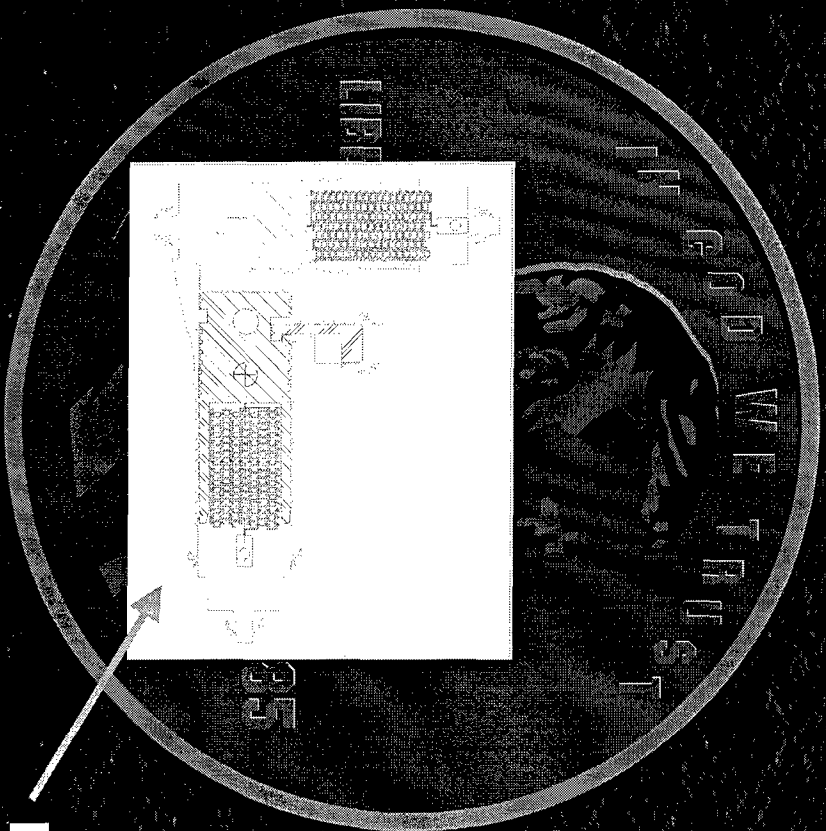

One-Cent Coin (USA)

MEMS Mechanical S&A Chip

Electronic Safe and Arm

Reduced Size and Cost ESAs for all Weapons

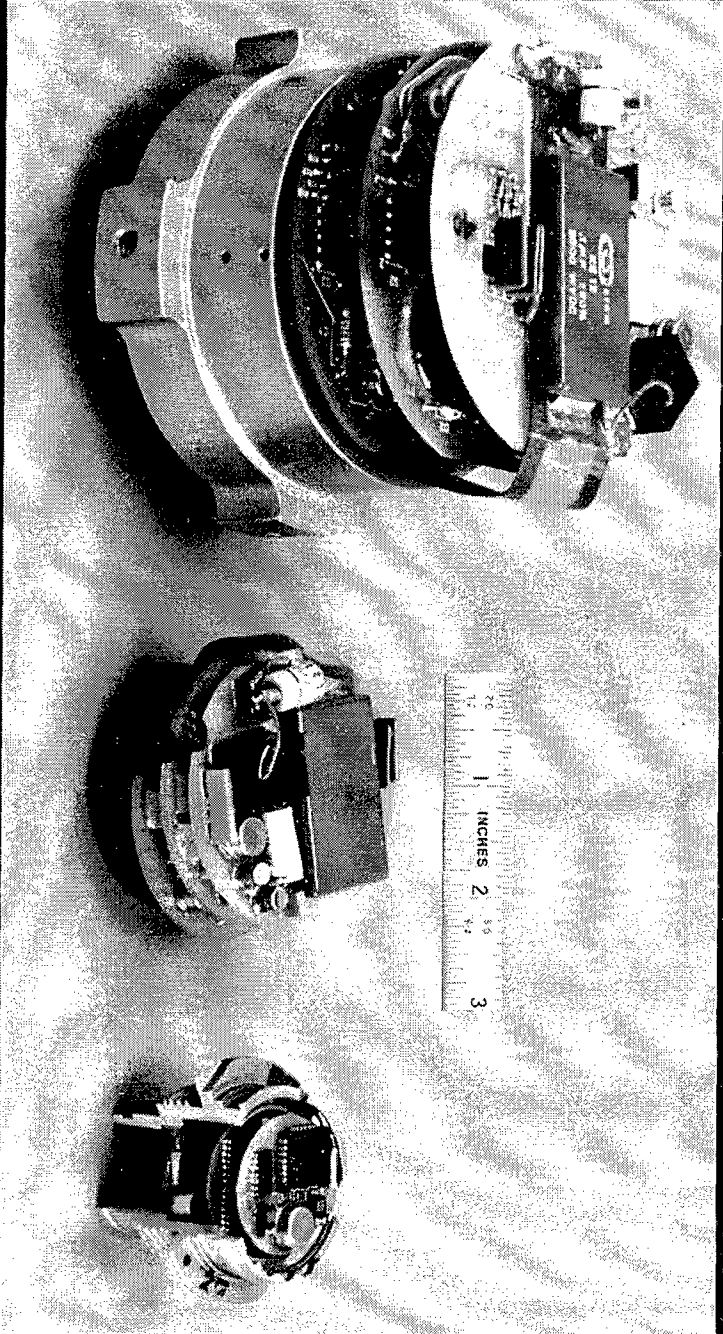

Missile

Smart Munition

Artillery and Mortar

APERS

- **User Has Identified a Need for a 120mm APERS Round in Korea**
- **No Off the Shelf Solution Available that Meets Users Needs**
- **User Wants 3000-5000 for One Theater**
- **No Complete Fuzing System Available That Satisfies AFSRB and User**

120mm APERS Alternatives

- IMI CL3288 with M120 Fuze - User Rejected Due to Human Factors Concerns
- Modular Concept Based on M830A1 HEAT-MP-T -
 - User Likes Concept, Approx 3 yrs to Qualify
 - Fuze Development Required
- ARDEC Concept with M120 - User Doesn't Like Fuze
 - 45-51 Months to Qualify
 - Fuze Development Required
- New Development - Everyone Gets What They Want
 - Long Development and Lots of \$

IMI CL3288

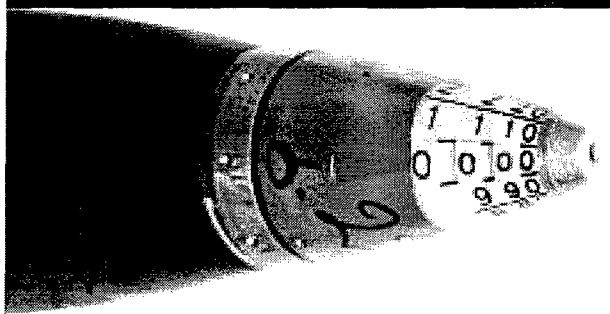
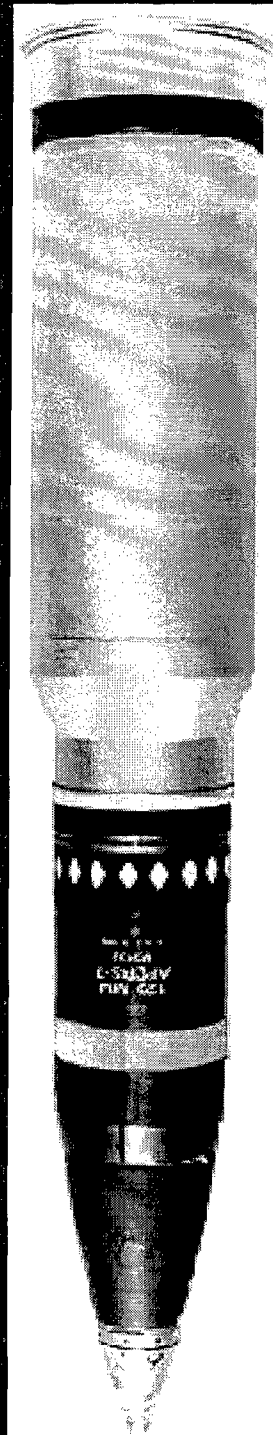

ARDEC Concept

Folding Fins

XM859

4150 Flechettes (13 grain)

Aluminum Body

Electronic
Time Fuze

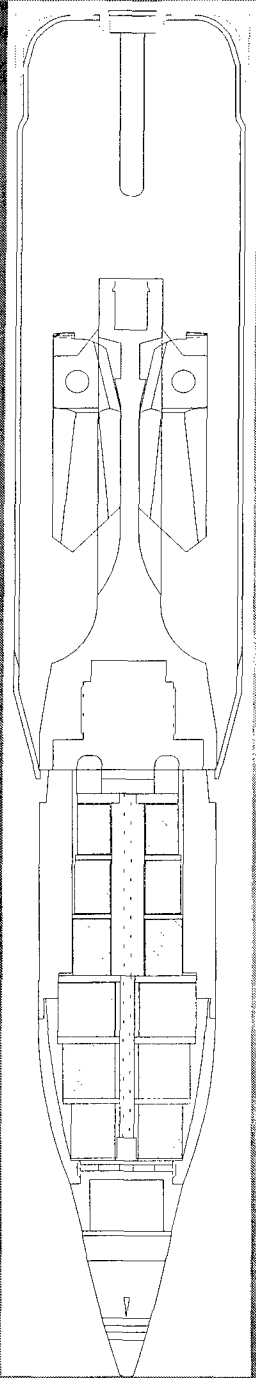

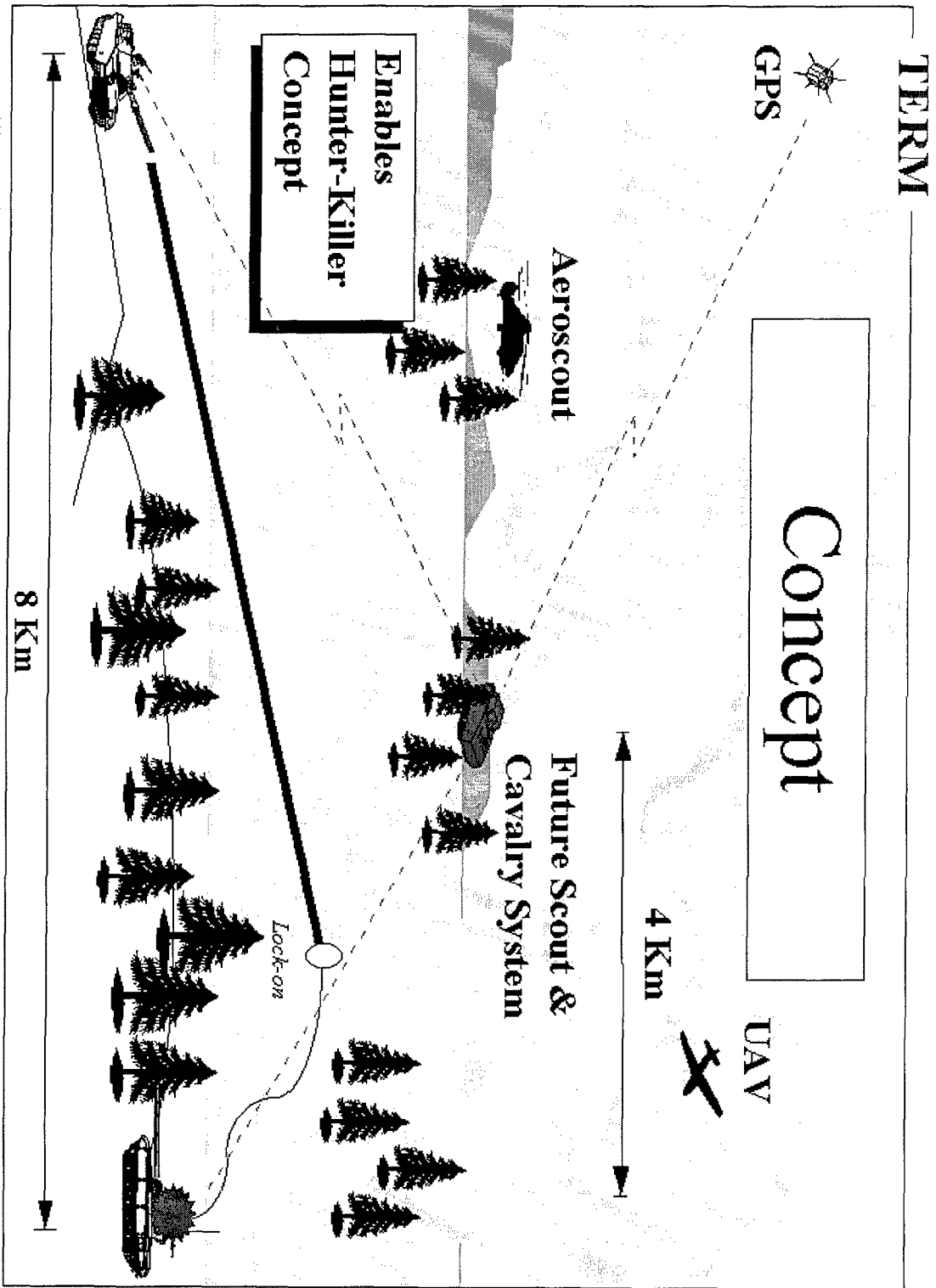

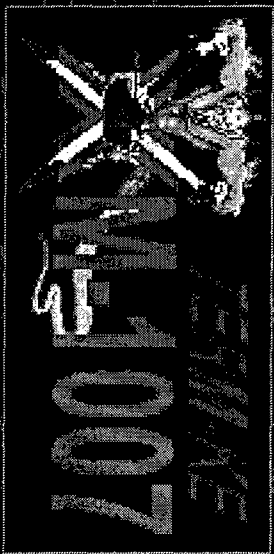

TERM-KBE

- Smart Tank Fired Munition
- Major Components:
 - DU Penetrator
 - Guidance
 - Rocket Motor Velocity Assist
- Congressionally Funded
- Competitor in Generic TERM Program

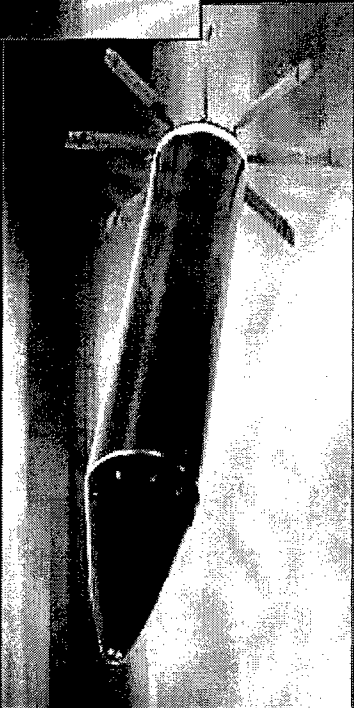
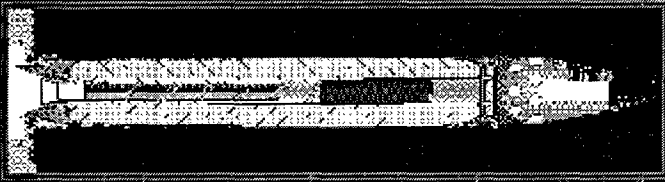

TERM-TA Concept

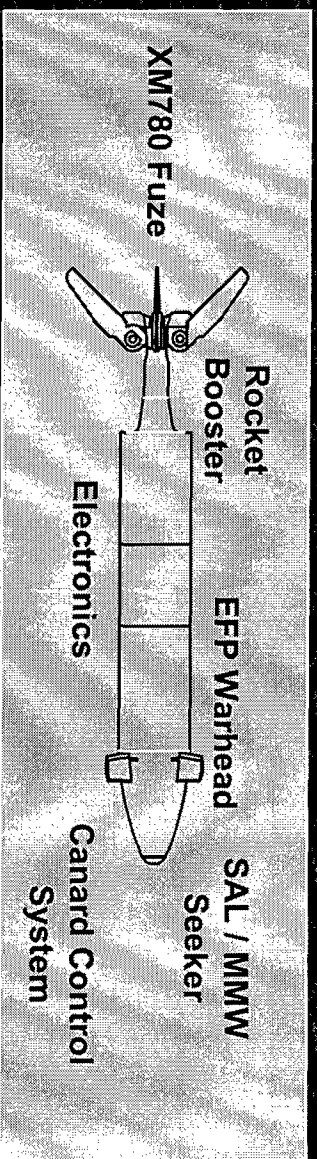

- Rocket Permits Lower G Gun Launch Reducing Cost, Complexity, Risk & Signature
- Inertial Guidance System Corrects for Uncompensated Wind
- Uncooled Strapdown SAL/IR Sensor Provides:
 - Precision Midcourse Guidance and Cued Target Acquisition
 - High P_k at Extended Range
 - Target Discrimination
- Cutting Edge MMW Provides:
 - Higher Resolution
 - Longer Range Acquisition

Tank Extended Range Munition (TERM)

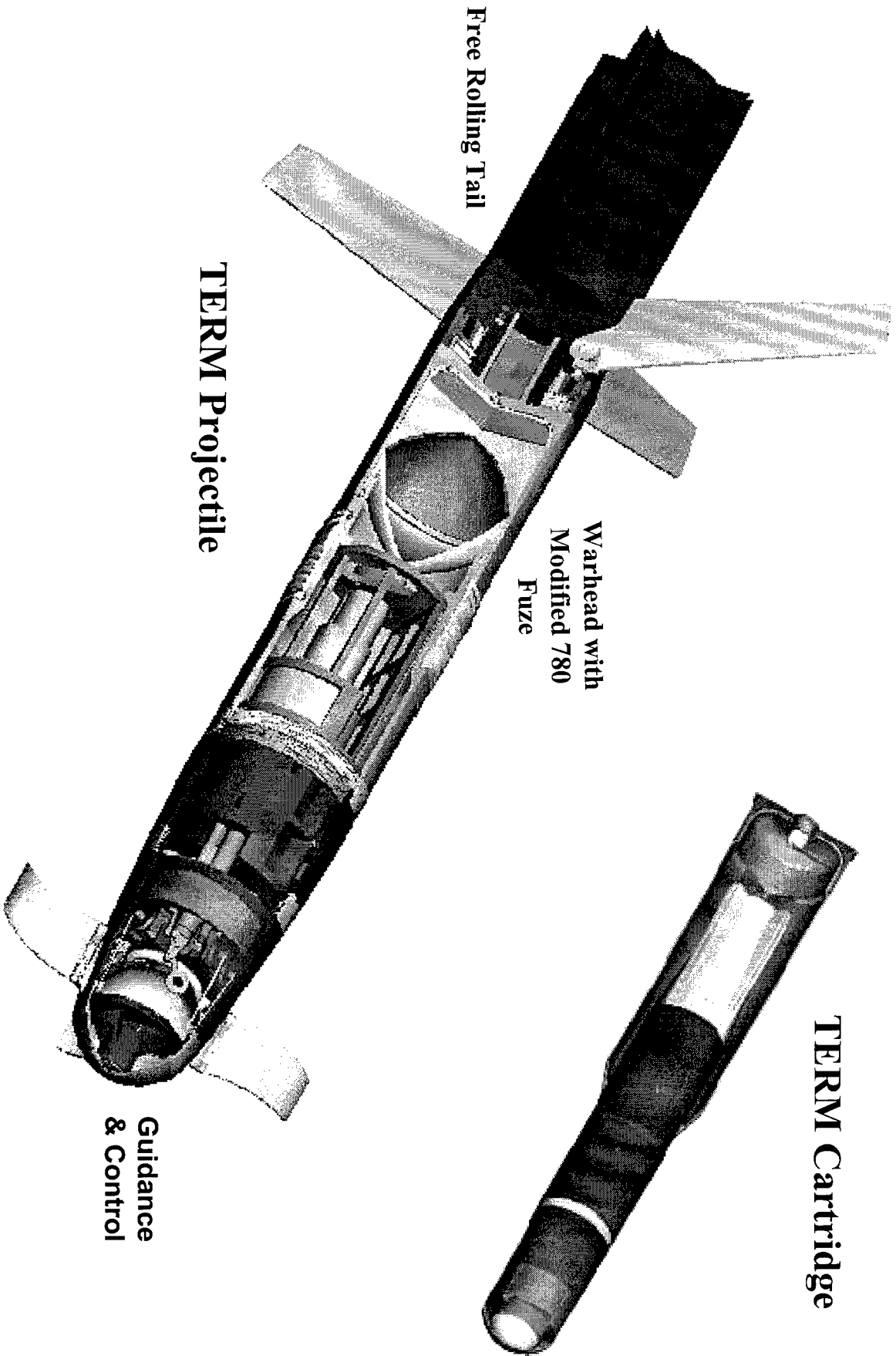

Free Rolling Tail

Warhead with
Modified 780
Fuze

TERM Projectile

Guidance
& Control

TERM Cartridge

Summary

**Direct Fire Application in 120mm
or Medium Caliber Requires a
Significant Investment of Tech
Base and/or IR&D Funds to Meet
Force XXI and AAN Fuzing
Requirements**

TERM VIDEO

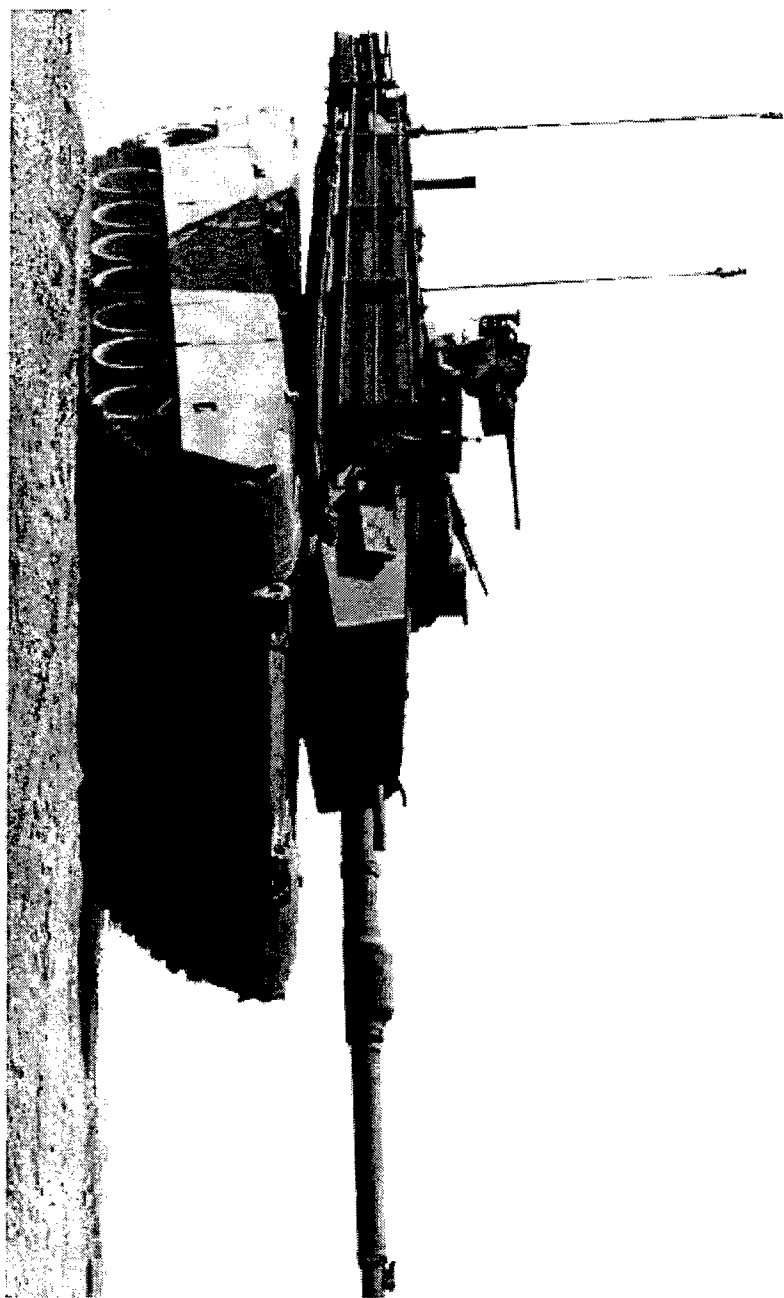

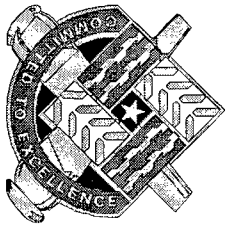

JACOM
*Mobility and Firepower
for America's Army*

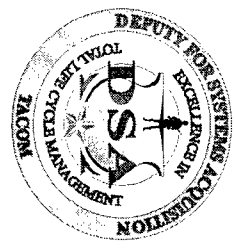

Anti-Personnel Landmine Alternatives (APL-A)

Briefing for 43rd Annual Fuze Conference

7 April 1999

Briefer: Col Thomas E. Dresen
Project Manager, Mines, Countermine
and Demolitions
DSN 880-7041

Tank-automotive & Armaments COMmand
Committed to Excellence



Outline

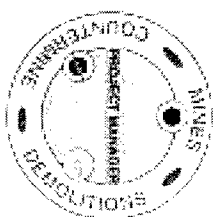

- Office Overview
- Background
- Why Anti-Personnel Landmines are Needed
- Ground Rules
- Acquisition Schedule and Approach
- Non-Self Destruct Alternatives
- Fuzing Challenges
- Parting Thoughts



Mines,

Countermine

&

Demolitions

PROJECT MANAGER

for

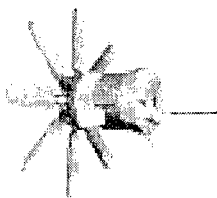
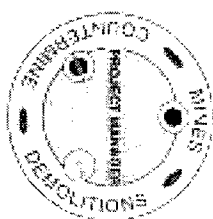

Wide Area Munition
(Hornet)

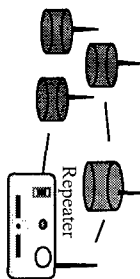

Non-Self Destruct
Alternative

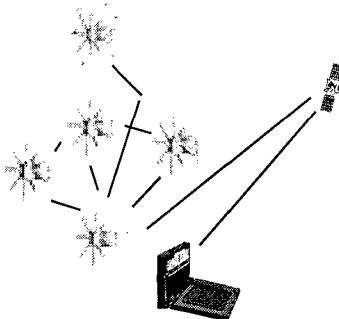

Intelligent Combat Outpost
(RAPTOR)

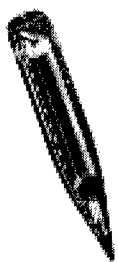

RAAM/ADAM
Mixed Projectile
(RADAM)



VOLCANO

*Anti-Personnel
Landmine (APL)
Alternatives*



Ground ST Andolt
Minefield Detection System

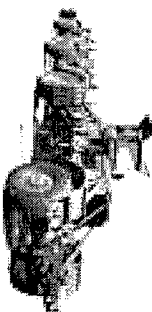

Interim Vehicle Mounted
Mine Detector



Explosive Standoff
Minefield Clearer

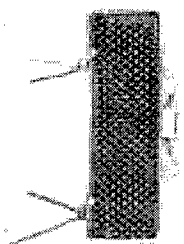

Modular Crowd
Control Munition

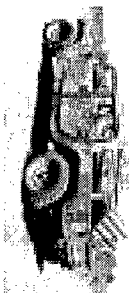

Canister Launched
Area Denial System

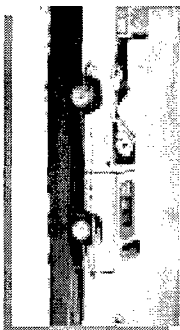

Portable Vehicle
Immobilization System

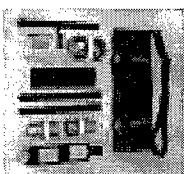

Fighting
Position Excavator



Selectable Lightweight
Attack Munition

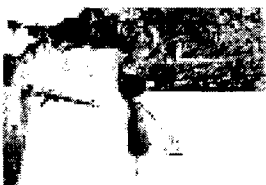

Penetration
Augmented Munition

Proc (6)	1253.1m
RDT&E (18)	531.7m
Total	1784.8m

*Non-Lethal
Weapons*

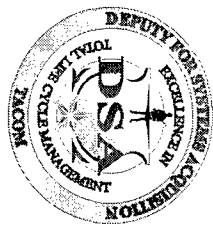

Background

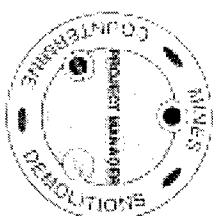

17 Sep 97 - POTUS Announcement

- ➔ • Develop alternatives to end use of Self-Destruct (SD) APL by 2003
 - » Retains use of “mixed” Anti-Tank/Anti-Personnel SD mine systems
- ➔ • Develop alternatives for Korea by 2006
- Increase funding for de-mining programs
- Increase efforts to establish serious negotiations in Conference on Disarmaments

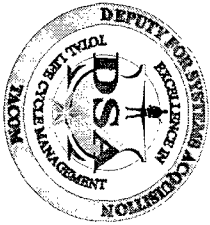

Background (Cont)

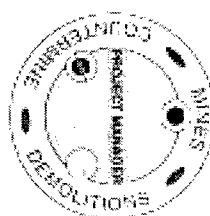

DepSecDef Directive - 21 Oct 97

Objective

- Redesign, repackage and retrofit RAAM into a mixed system
- Develop and implement an alternative to the PDM
- Develop and implement alternatives to meet the requirements currently met by APLs (both non self-destructing and self-destructing), particularly in Korea

Acquisition

- Track 1: Army lead. Develop final APL requirements, and initiate an accelerated acquisition program to achieve the objectives
- Track 2: DARPA lead. Investigate maneuver denial approaches that are more innovative and that take advantage of advanced technologies

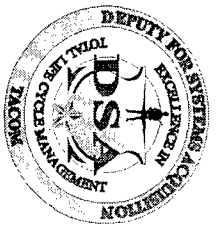

Presidential Decision Directive (PDD/NSC-64, 23 June 1998)

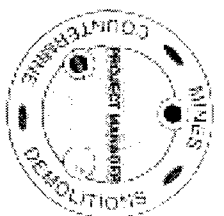

- Develop alternatives to end the use of all APL outside Korea by the year 2003 - date certain (Track I)
 - Retains use of mixed AP/AT SD systems
 - Develop a new mixed system called RADAM
- Aggressively pursue alternatives to APLs for Korea by 2006 - objective not a deadline
- Search aggressively for alternatives to our mixed anti-tank systems - No deadline (Track III)

“However, the U.S. will sign the Ottawa Convention by 2006, if we succeed in identifying and fielding suitable alternatives to our APL and mixed anti-tank systems by then.”

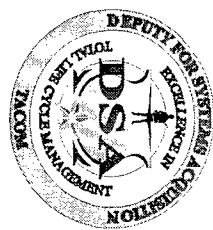

Why Do We Need APL?

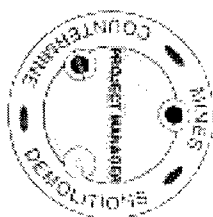

- APLs act as a force multiplier
 - Deny unrestricted maneuver for enemy
 - Delay to enhance weapons effects
 - Provide alert/warning
 - Produce direct casualties
- APLs serve many roles
 - Protective obstacles
 - Protect AT minefields
 - Cover blind avenues of approach
 - Deter pursuit
 - Augment static barrier

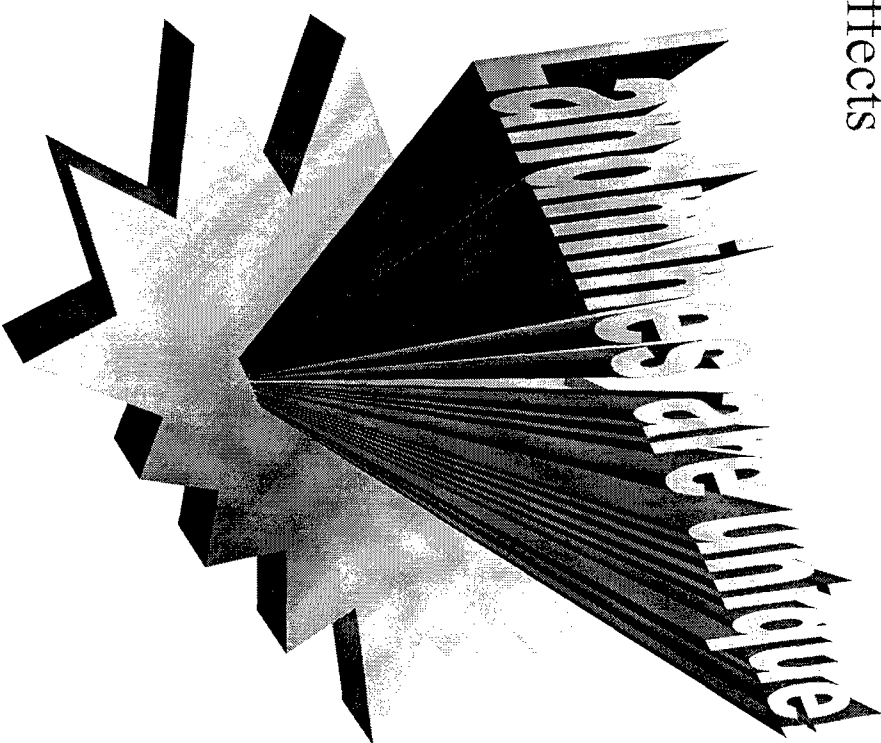



MSD-A Ground Rules

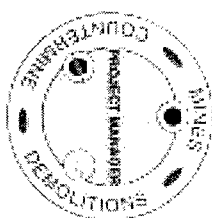

- Cannot be AP mine - No target activation(if lethal)*
- Equivalent operational effectiveness to existing systems
- Leave residual threat no greater than existing systems
- Target discrimination capability need not be better than existing systems
 - IFF/Visual target confirmation not required
 - Rely on situational awareness
- Emphasis on fast fielding

*Anti-Personnel mine means a mine primarily designed to be exploded by the presence, proximity or contact of a person and that will incapacitate, injure or kill one or more persons.



Innovative NSD-A Acquisition Approach

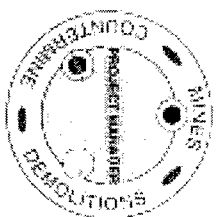

- Accelerated Administrative Lead Time - Source Selection completed May '98
 - Formed Acquisition and Requirements Tiger Teams
 - Hosted Industry Day to discuss requirements and Government studies
 - White Papers evaluated on preliminary concepts
 - Government paid for proposal preparation
- Broad support in preliminary studies, evaluations and planning
 - Government Labs (ARDEC, CECOM, Night Vision Labs, Army Research Labs, Sandia, Lawrence Livermore, Joint Non-Lethal Weapons Office,)
 - Diverse User Support (Engineer School, Infantry School, USMC, US Forces in Korea, J8)
 - Analysis Contractors (MITRE Corp., Institute for Defense Analysis)
- MS II 12 months after contract award

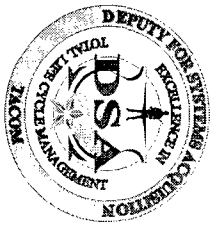

What Is NSD-A

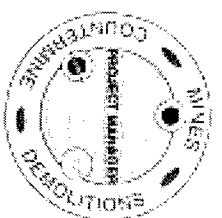

- Non-Self Destruct Alternative
 - Hand-Emplaced Munition Being Developed To Meet Mission Requirements Formerly Accomplished By M14 and M16 Mines.

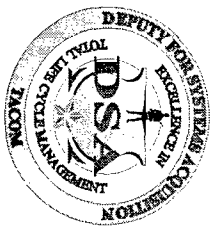

Mines Have:



- Sensors To Detect And Locate Intrusion (Tripline or Pressure Sensors)
- Firing Circuitry To Direct Response
- Mechanism To Deliver And Provide APL Effects

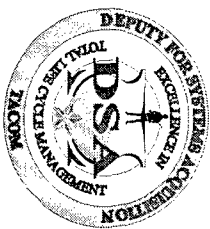

NSD-A Concepts Have:

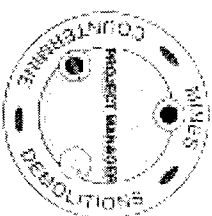

- Sensors to Detect And Locate Intrusion
- **Command & Control System to Direct Response**
- Mechanism to Deliver And Provide APL Effects

Essential Feature of Replacement Concepts is
Man-in-the-Loop

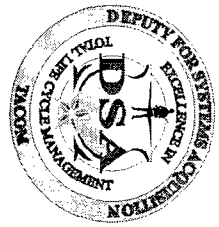

Generic NSD-A Concept

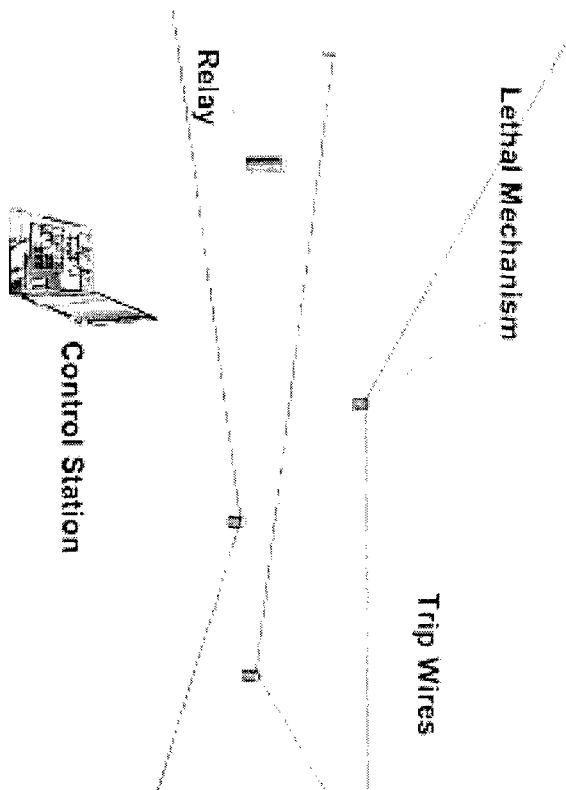
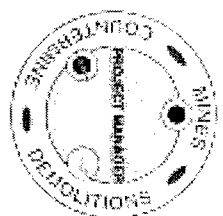

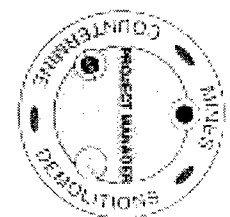

NSD -A

Program Schedule (Track 1)

FY 98	FY 99	FY 00	FY 01	FY 02	FY 03	FY 04	FY 05	FY 06	FY 07	FY 08
-------	-------	-------	-------	-------	-------	-------	-------	-------	-------	-------

PALT Procurement Administrative Lead Time - 8months

▲ MS 0 (Plan to SECDEF)

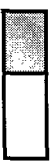

Prototype Assessment Test (PAT) - 12months

△ MS I/II (Downselect) & ORD Available

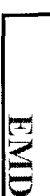

Engineering & Manufacturing Development - 30months

△ TC-STANDARD (MS IID) (PRODUCTION DECISION)



△ Material Release (Initial Operational Capability)



NOTE: Funded through POM years

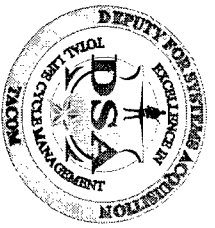

Fuzing Challenges



- ORD Requirement For Recoverability
 - Command Control through RF Transmission While Maintaining Hazardous Device Requirement of Less Than 1 per Million
- Firing Train Components In-Line
- Safety Indications Need To Be Acknowledged From A Distance

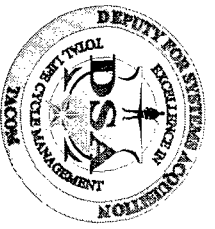

Beyond NSD-A

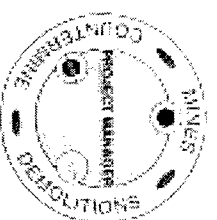

- Technologies being inserted into NSD-A will be essential features for future APLA systems
 - Communications with munitions
 - Recoverability
 - Control display
 - Situational awareness
- Track III (Mixed System Alternatives)
 - Expand Command & Control For Deep Deployment
 - Multiple Delivery Platforms
 - Push State of The Art On Discriminating Sensors
 - On-Off-On
- Integrate into an overall Area Denial System that will provide for Unmanned Terrain Dominance

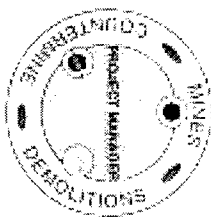
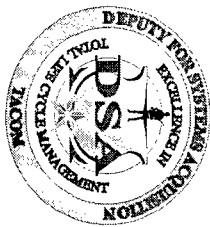

Parting Thoughts

- NSD-A
 - On track to provide capability for USFK
 - Many Fuzing challenges - Human interface, Man-in-the-loop
- Mixed Systems Alternative
 - Many challenges ahead
 - Established OSD WIP/T that will define and execute 15 month Concept Exploration Phase
- APLA programs funded through POM
years

Presented by:
BG John Deyermund
DCS Ammunition

Army Materialiel Command

**Ammunition Update
to NDIA
Fuze Conference
7 April 1999**

AMC - Relevant, Responsive & Ready!

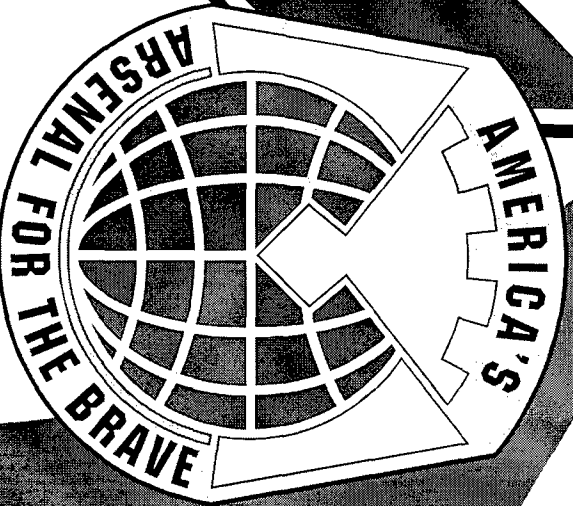

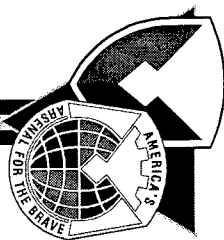

Current Ammo Issues

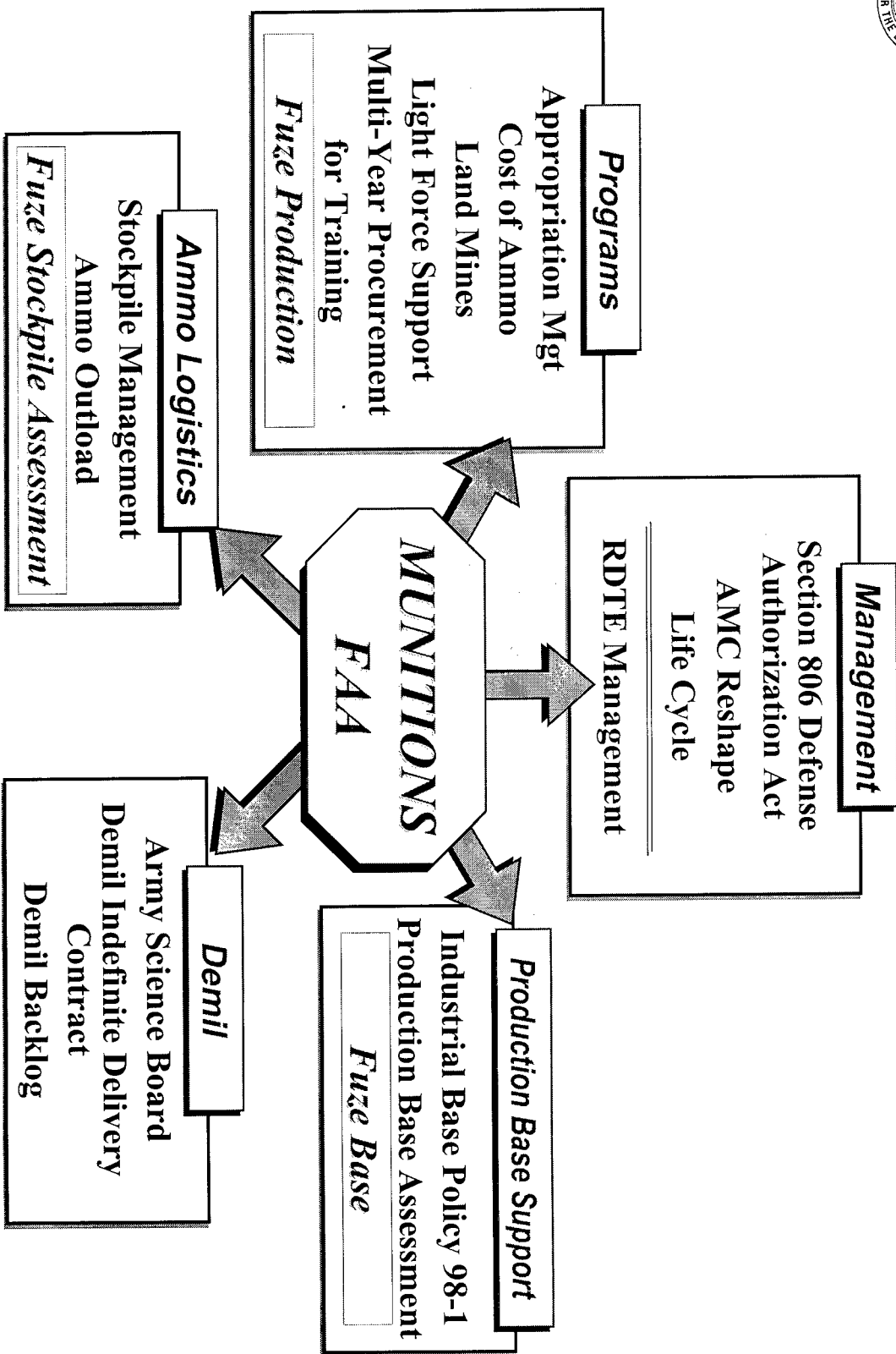

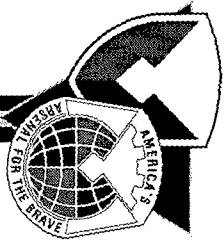

FAA Preparation

Team Approach

- HQ DA - DCSOPS, DCSLOG, PAE, SARDA, ASAFM
- Industrial Operations Command
- MRDEC/AMCOM
- ARDEC/TACOM
- PEOs - Tactical Missile GCSS
- TRADOC

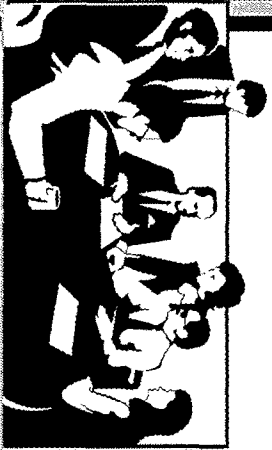

Who Has Seen:

Council of Colonels	28 Jan 99
GOSC	19 Feb 99
AMC Commander	23 Feb 99
ADCSOPS -FD	26 Feb 99
ADCSLOG	3 Mar 99
MIL DEP to	
ASA, ACQ, LOG, TECH	3 Mar 99
DCSOPS	2 Mar 99
ADCSDDCD, TRADOC	3 Mar 99
VCSA	5 Mar 99
CSA	8 Mar 99

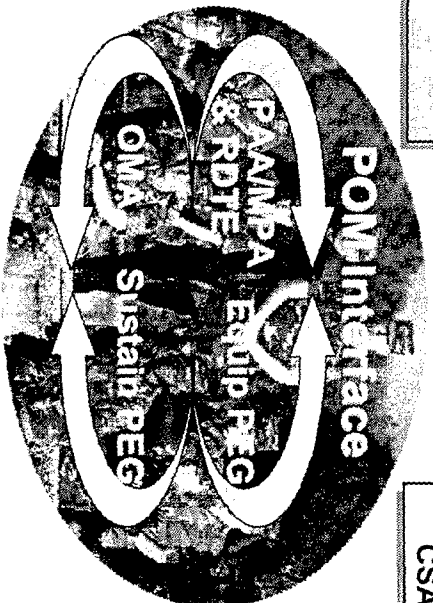

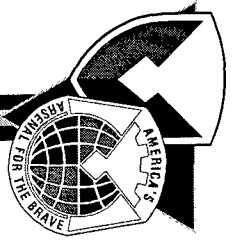

Bottom Line Up Front

Assessment

- **Introduction**
 - **Requirements, No Issues**
 - **RDT&E - Underfunded, missing investment opportunities**
 - **Missile Program - Issue: AT support for light forces**
 - **Ammo Program**
 - **Training Program, solid**
 - **War Reserve Modernization for heavy forces, good, light forces weak**
 - **Production Base weak**
 - **Stockpile Management - okay with PBD 751**
- **Conclusion**

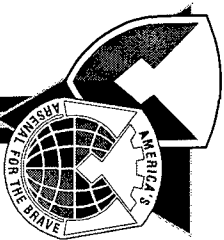

Conclusions

- * Requirements calculation a dynamic process - Multiple ongoing efforts - Will Report Out Separately
- * RDTE underfunded - delaying munitions development, fielding - missing investment opportunities
- * Missile Program and Ammo Program - RISK in support of Light Forces in Force XXI
 - * Production base needs attention
 - Ammo - Costs of reshaping
 - Missile - Selected program replenishment
- * Stockpile management healthy after application of PBD 751 but must watch Army Strategic Mobility Program progress and work personnel, MHE issues

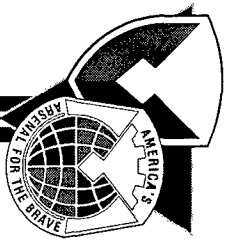

Recommendations

- ★ Continue with studies - apply to POM 02-07*
- ★ Consider application of surplus from PBD 751 to unfunded/underfunded light force munitions programs FY03-05*
- ★ Work production base cost issues with OSD*



PAA - Funding Profile

PAA Historical Trend (\$M)

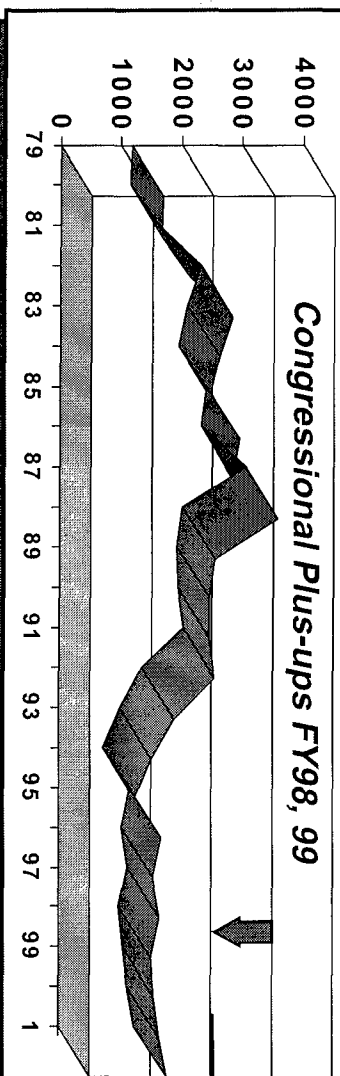

Today's Production Reflects Yesterday's Funding -

Procurement as a Percentage of Army Budget - FY00/FY01

Appropriation	FY00	FY01
FAMILY HOUSING	1,112	1,062
MIL PERSONNEL	27,848	28,748
RDTE	4,426	4,750
MCA	695	1,843
OMA	22,934	23,705
PROCUREMENT	8,569	9,532
ERA	378	383
BRAC	155	409
CHEM DEMIL	1,169	986
AWCF	62	63
TOTAL*	67,349	71,481

*Totals may not add due to rounding

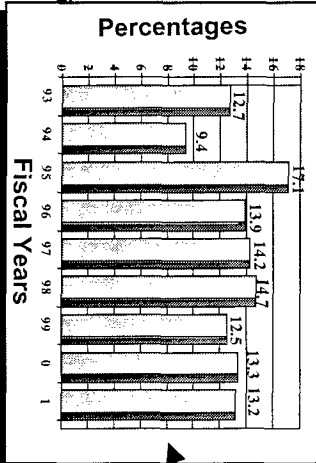
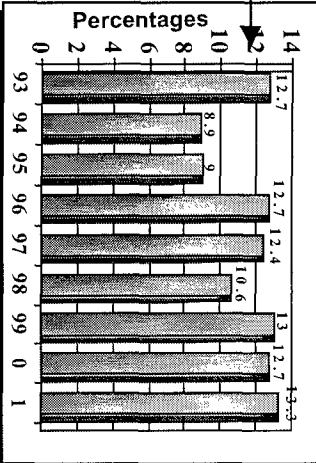

Appropriation	FY00	FY01
AIRCRAFT	1229.8	1311.8
MISSILES	1358.1	1413.3
WTCV	1416.8	1499.8
AMMUNITION	1140.8	1256.9
OTHER PROCUREMENT	3423.9	4050.4
TOTAL	8569.4	9532.2

Ammunition as a Percentage of The Procurement Budget - FY00/FY01



Army Ammo Funded Requirements

FY99

PAA

FY00

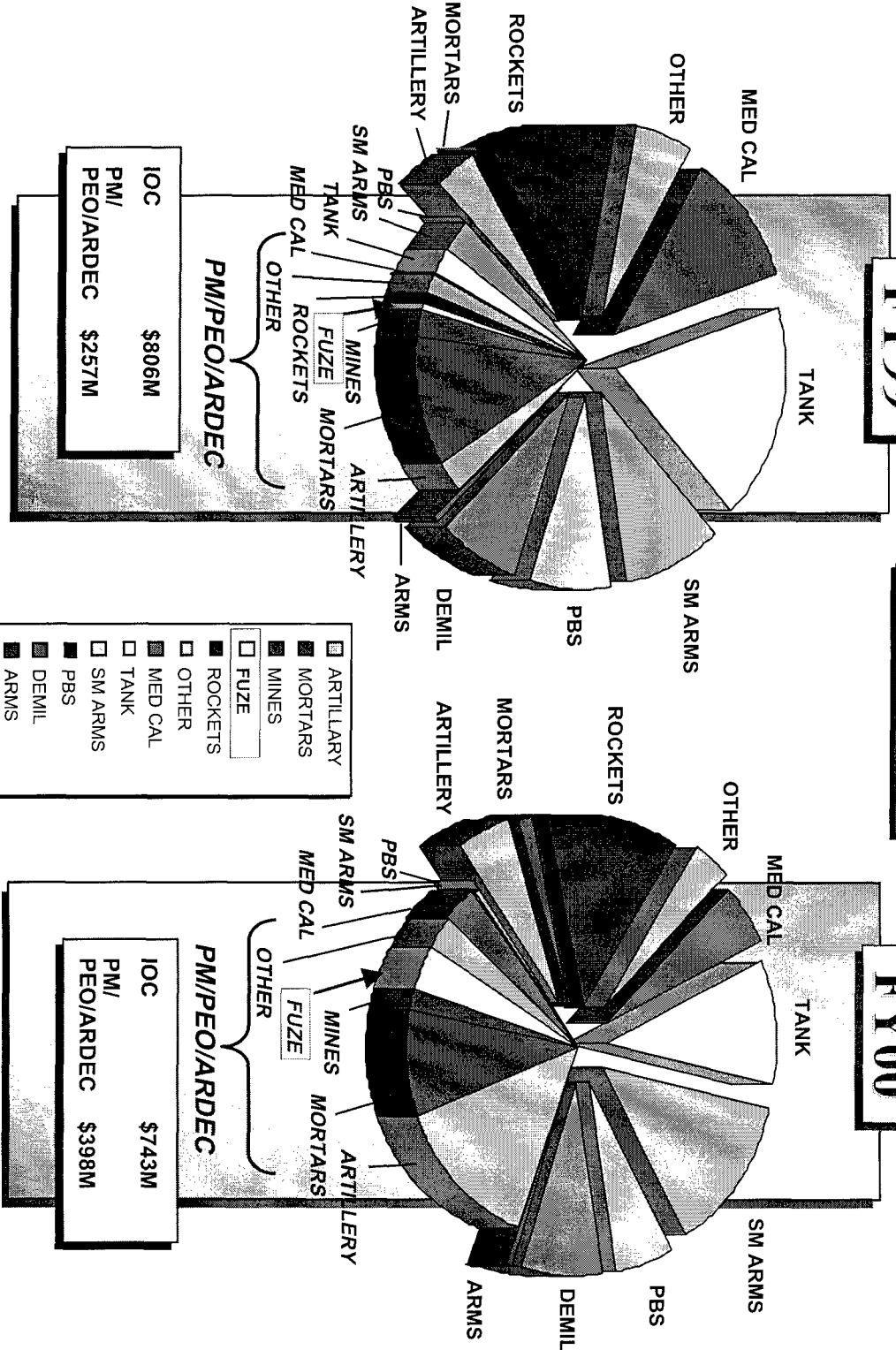

IOC \$806M
PM/PEO/ARDEC \$257M

IOC \$743M
PM/PEO/ARDEC \$398M



Ammunition Procurement Projection by Categories

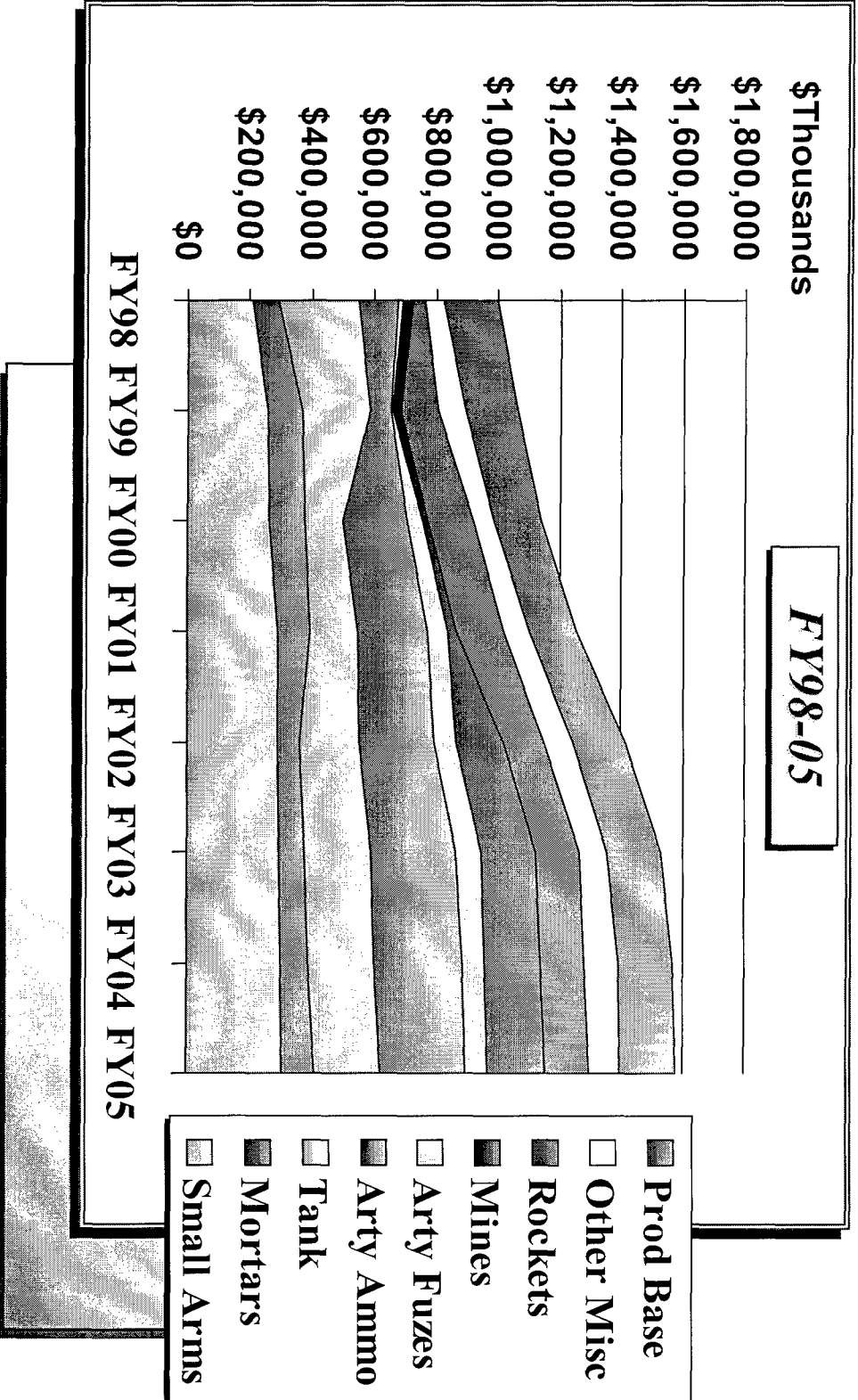



Ammunition Production Base

FY00-01 Budget

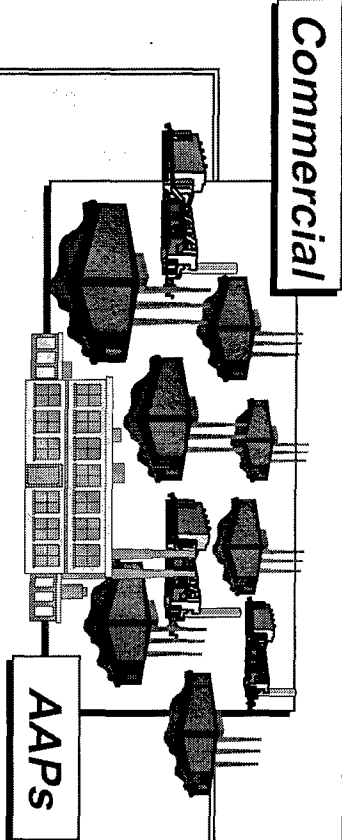

Activity 2 PAA Funding

	\$ Million	
	FY99	FY00
Industrial Facilities (IF)	50.5	46.1
Layaway of Industrial Facilities (LIF)	15.3	3.5
Maintenance of Inactive Facilities (MIIF)	15.8	13.0
Conventional Ammo Demil	82.7	86.3
Arms Initiative	4.8	4.8
Totals (\$ in Mil)	169.1	153.7

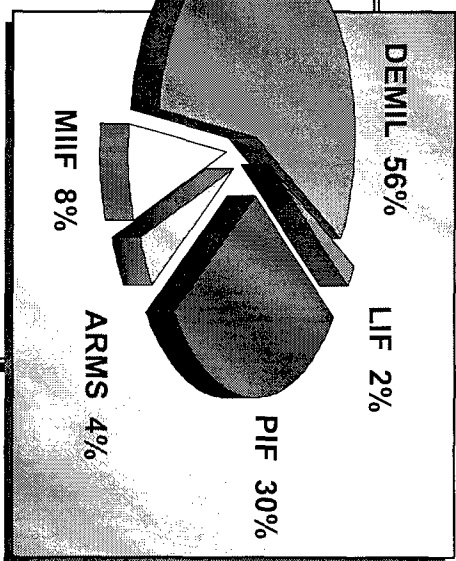

Challenge
Production Base
vs.
Hardware

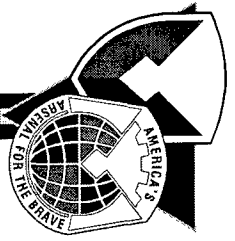

Active Conventional Fuze Industrial Base Producers

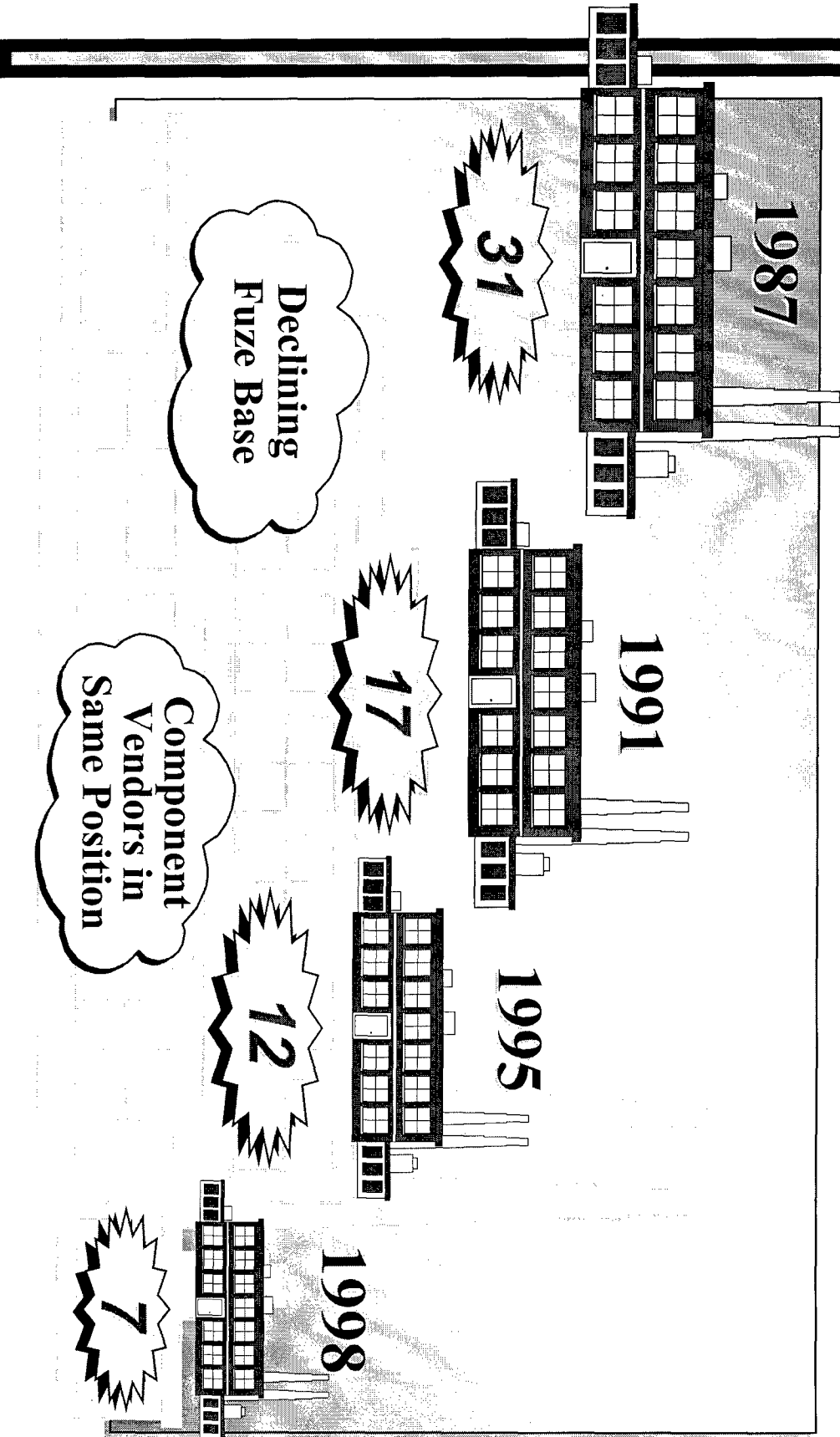

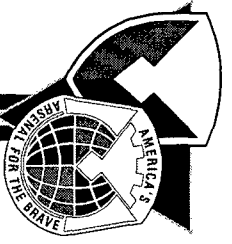

Active Conventional Fuze Industrial Base

April 99

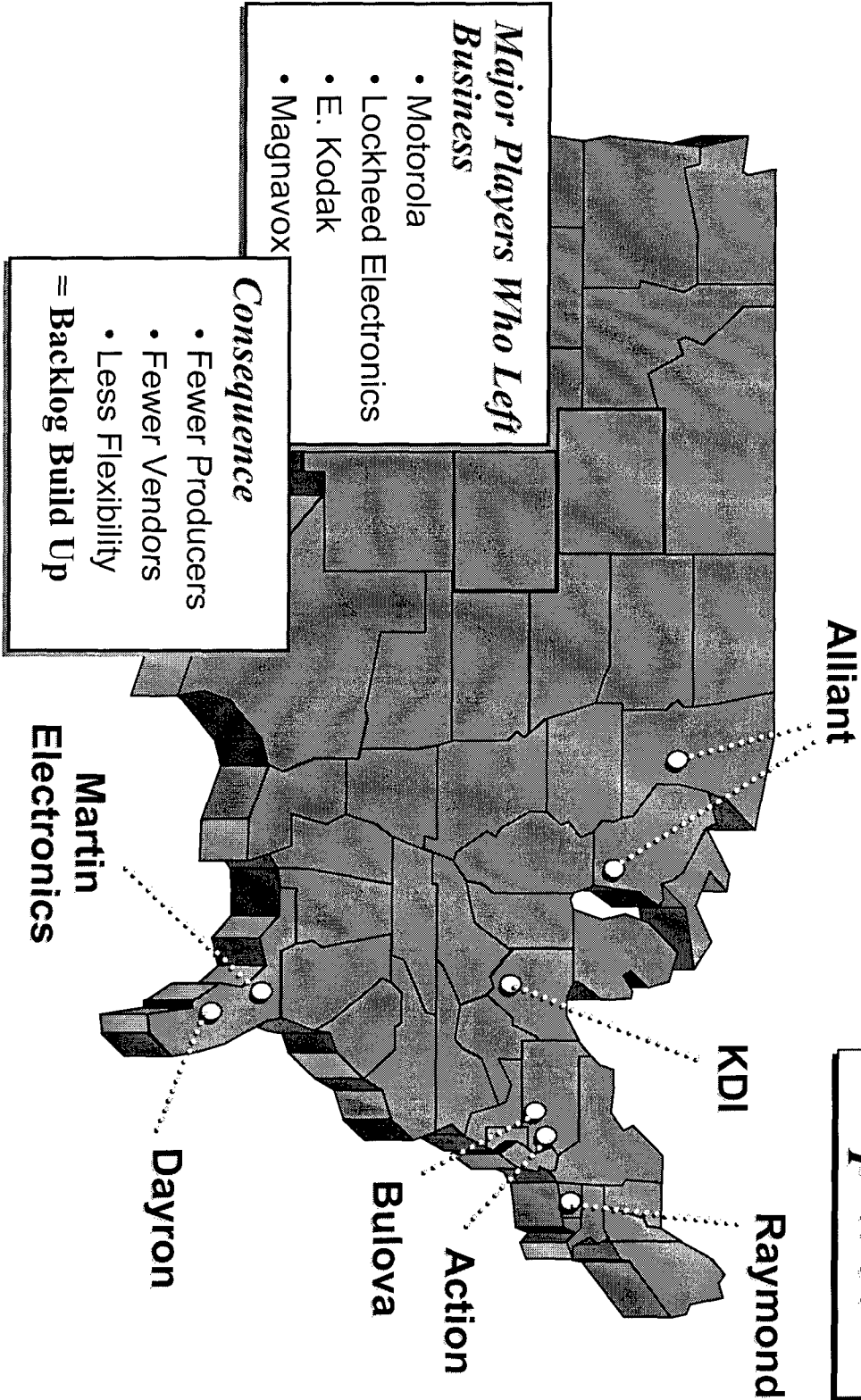



Work in Progress FY91-98 Orders

As of: 31 Dec 98 Total Orders - \$10044M

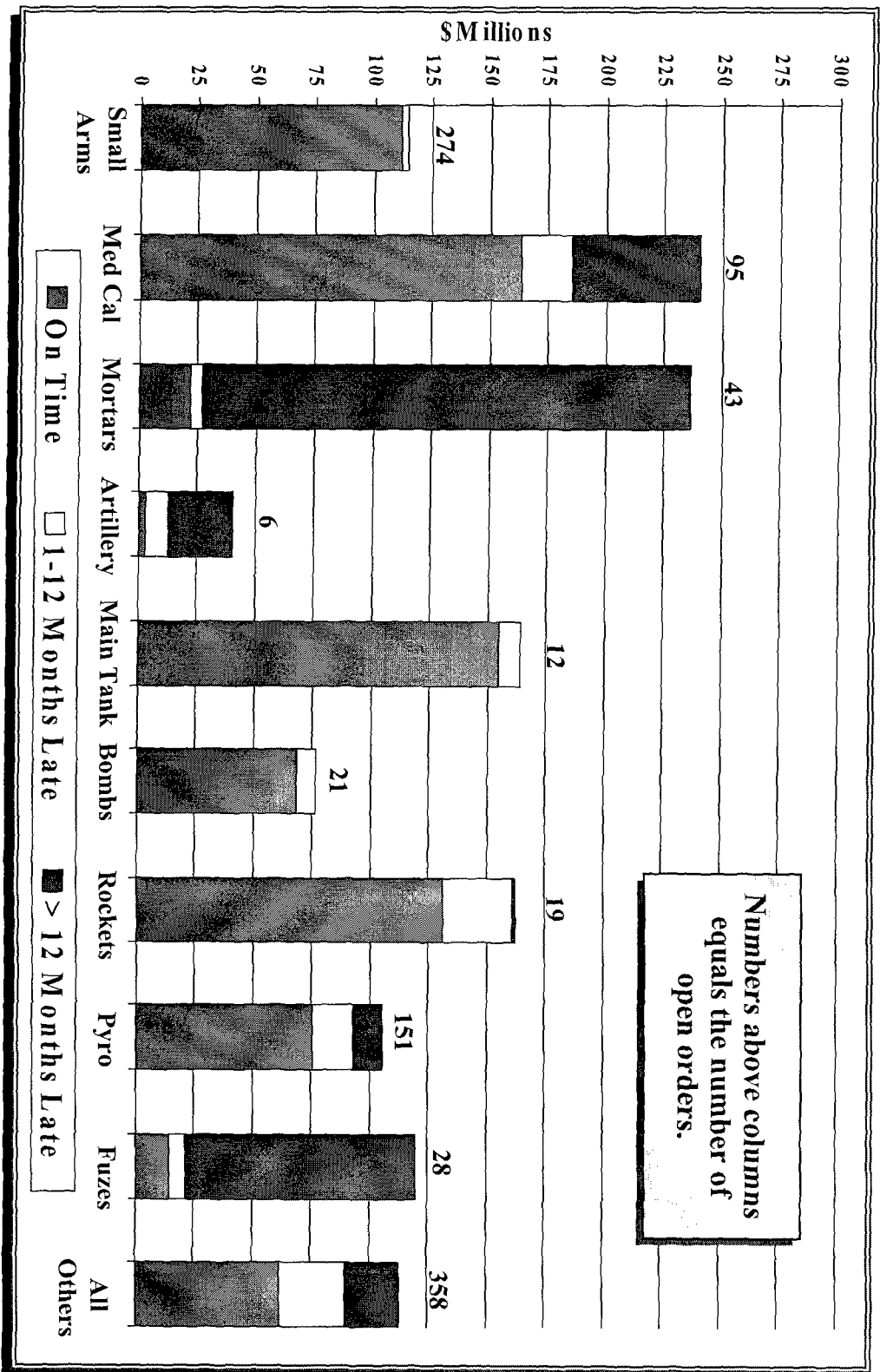

Numbers above columns equals the number of open orders.



IOC/SMCA Work In Progress (WIP)

FY98 and Earlier Orders: as of 31 Dec 98

Fuzes

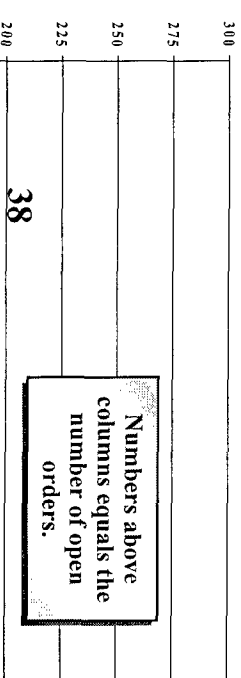

Delinquent Orders Section	Customers	# of Orders	MIPR Value-\$M	Undel Value-\$M
Mortars	A, M, N	29	306	209
Fuzes	All	12	212	99
Med Cal	All	16	89	55
All Others	All	54	177	64
Total		111	784	427

DODIC	Principal Delinquent Fuze Orders Nomen	Value-\$M	Undel-\$M	Orders
F770	Fz FMU-140	131	24	2
N291	Fz M732A2	52	49	3
N659	Fz Mk 399 Mod 1	7	6	1
NA01	Fz FMU-153/B	14	13	2

Orders	Orders in Progress				Total
	Green	Amber	Red		
0Q99	20	4	14	38	
1Q99	14	2	12	28	

Getting Better
10 of 38 Orders Delivered
Since 7 Oct 98

Delinquent/Red - > 12 months beyond planned production.
Late/Amber - 1-12 months beyond planned production.



Fuze Backlog

Fuze

Problem

M732A2

FY91 Funded Program

TDP was not ready for Production
Redesigned ASICs ran into technical
& manufacturing difficulties
Redesigned battery needed
qualification
S&A needed qualification

MK399/FMU153-B

FY91 Funded Program

Original contract with REXON had to
be terminated
New contract ran into difficulties
getting explosive components from
vendor



Fuze Base Concerns

Since 1995, you have expressed your concerns:

- Declining Business Base
- Reduced Availability of Explosive Components
- Electronic Component Obsolescence
- Limited Fuze Development Opportunities

*AFMO Fuze
Base Study
1997*

DCS Ammo / AFMO Approach:

- Material Change Proposal Using Production Dollars
- Fuze Stockpile Assessments
- EED Initiative
- Still Working Fuze Development Issues



Fuze Procurement by Categories: FY96-05

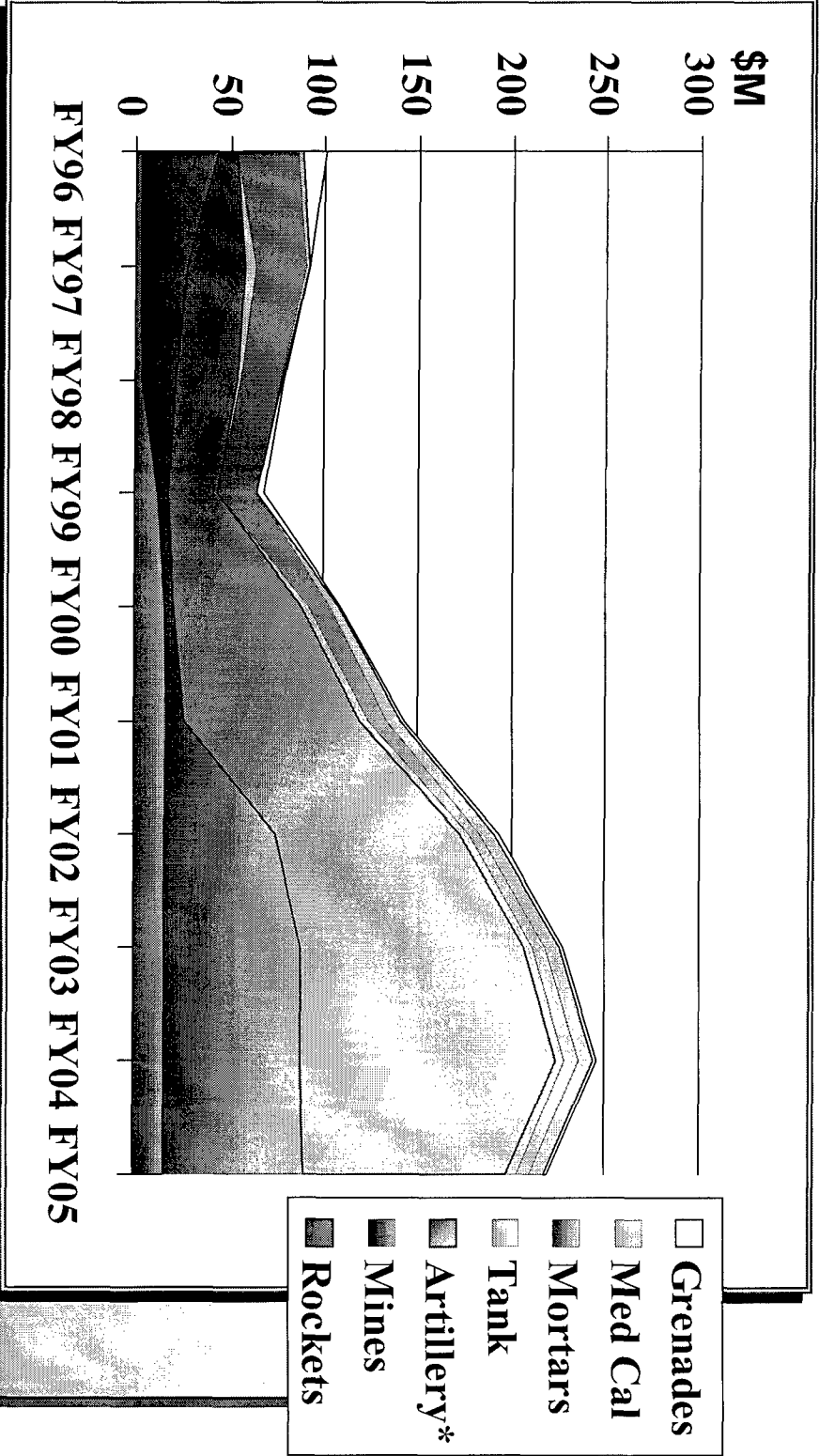

* Includes SADARM TDD and S&A



Projected Army Procurement of Ammunition Impacting the Fuze Base

In FY 00-01

- * **A. 60mm, 81mm & 120mm Mortar Ammo With:**
 - M734A1 MO
 - XM783 PD
 - M772/M776 MT
 - M781 Tng Fuze
- * **B. Artillery Fuzes**
 - M767E1/M762E1 ETSQ & ET Fuzes
 - XM782 Multi-Option Fuze for Artillery
- * **C. Other**
 - Hydra-70 Rockets
 - Mine Warfare Alternatives

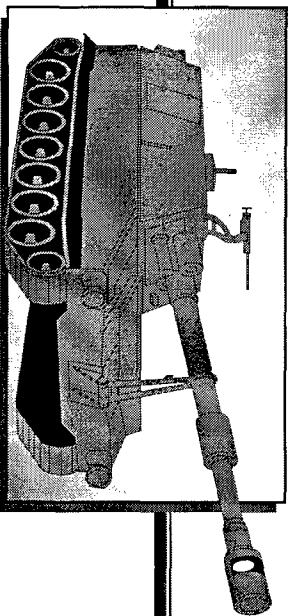
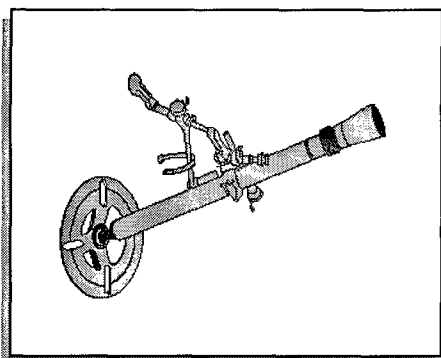



Current Fuze Stockpile

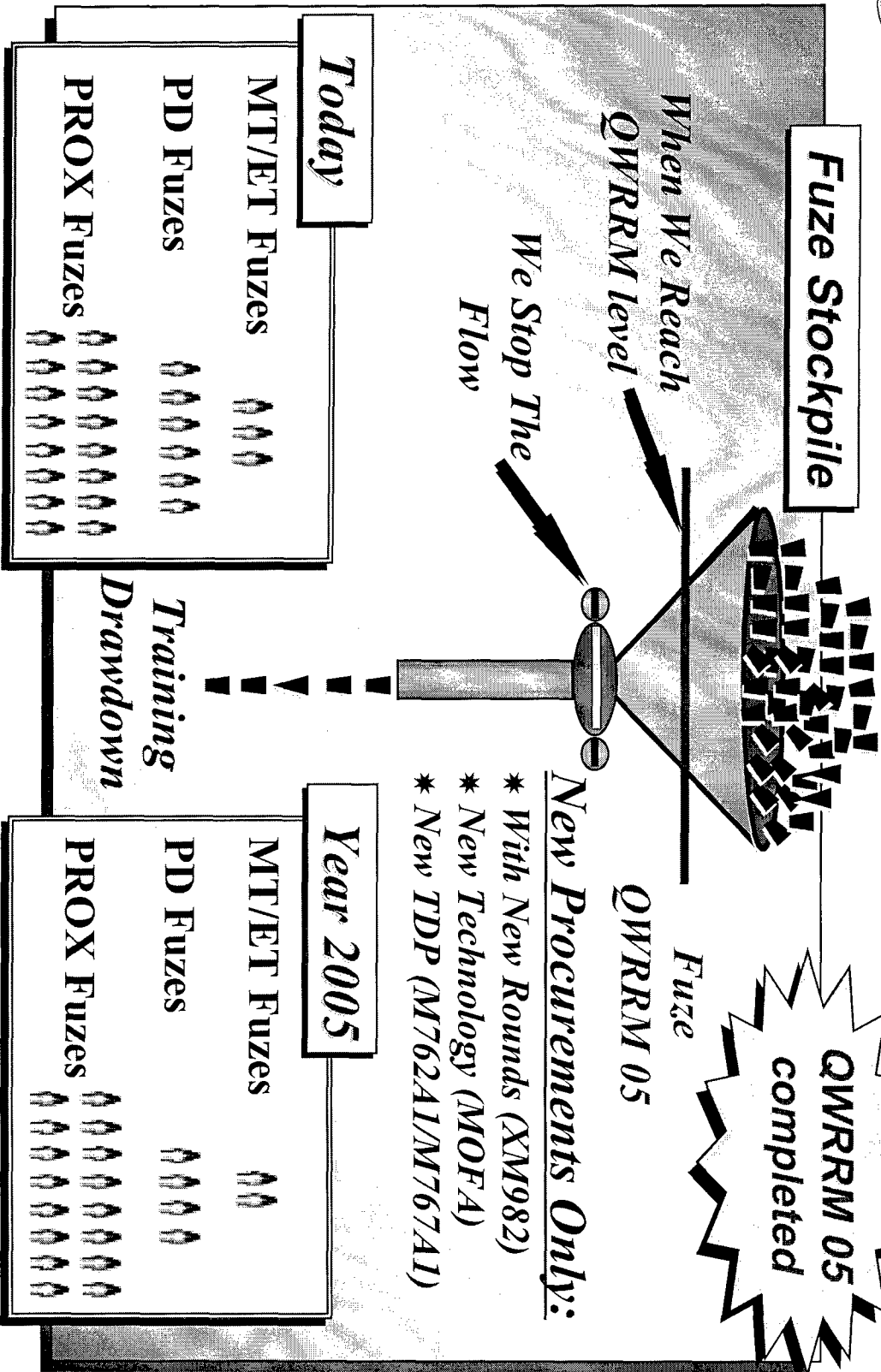

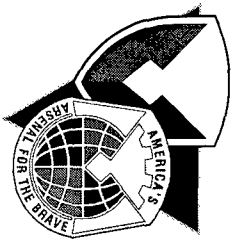

Time Fuze Inventory

Results of Government-Industry Stockpile Evaluation

Mechanical Time Fuze

2.7 M

Becoming Unserviceable

Vintage ~20 Yrs

M577 Basic

2.0 M

Degradation in Progress

10-20 Yrs

M577 A1

1.8 M

In Acceptable Condition

Supports WR Requirements < 10 Yrs Old

Shelf Life Demonstrated to be an Issue!

M577 SSI

Electronic Time

0.7 M

Good Condition

Supports WR Requirements 1-5 Yrs Old

Compatibility with SADARM an Issue

M762 Basic

This Rationale Used to Justify New Procurement of M762 ET Fuzes

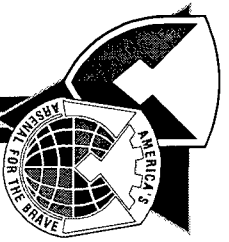

Ongoing Fuze Initiatives

M767A1/M762A1 Product Improvement Program

- Older variant producibility - electronic component obsolescence
- Needed limited support for training
- PIP ongoing

M762A1/M767A1 Procurement -

- Outgrowth of health of fuze inventory study
- Intended to replace aging MT fuzes
- Also training component
- Potential for multiyear program following PIP demonstration

XM783 Universal PD Mortar Fuze

- Replaces M745 and M935
- Used in all mortar calibers

Awarded Fuze EED Contract

- Response to Industry Concerns and Government Study in FY97
- Developing Qualified Source for EEDs

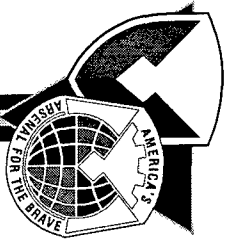

Electro-Explosive Devices Initiative

- * With the Departure of Dyno Nobel and ICI Americas from the US Industrial Base in the Mid-1990's, the Fuze Energetic Components Base Degraded Substantially
- * Industry Did Not Adequately Fill the Void
- * Fuze Production Was Severely Impacted Leading to Significant Delinquencies
- * Replenishment Capability Was Compromised



Electro-Explosive Devices Initiative

(cont'd)

- * Thru full & open competition, new source established to meet the stopgap
- * Contract awarded to Action Mfg Co. in Jan '99
 - will be qualified for about 14 key components
 - Service PMs will have a "qualified source" for these components
 - PMs to include additional components as needed
- * *This source available to all Primes and other Fuze Contractors on equal basis*



Closing Comments

With Fewer Fuze Producers, We Are Facing Greater Pressure to Deliver

We Are Moving Out to Address Concerns You Have Voiced with Respect to Industrial Base

Latest Congressional Language Allows Single Manager for Conventional Ammunition to Restrict Procurement to North American Base

Looking Ahead, Fuze Dollars on an Upswing

NAVAL SEA SYSTEMS COMMAND

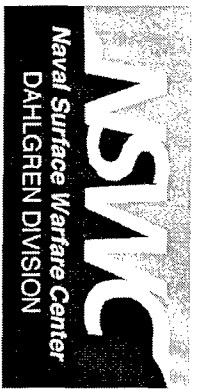

Panama City

Dahlgren



Mr. Mike Till

NSWC Dahlgren Division





Parama City

Dahlgren

FUZE BRANCH

G34

FUZE BRANCH

MICHAEL TILL

2T AMMO/FUZE DESIGN AGENT

SCOTT POMEROY
KIM JONES *

CHIEF ENGINEERS

HOWIE WENDT, EE
KEITH LEWIS, ME

SECRETARY

REGINA CAMPBELL

ELECTRICAL GROUP

SCOTT VANDERVIJLT

MICHAEL LUKAS HOLLY YEH
DAVID GEORGE YO SONG
SARWAT CHAPPELL
YOGESH GOHEL
FRANK LAGANO
ROSS MAYO
WAYNE WORRELL

MECHANICAL GROUP

B. LEE WILL

KEVIN BOHLI
SCOTT JACK
BRUCE LEAMAN
GENE MARQUIS
ANDY WYMAN

SPECIAL ASSIGNMENTS

MFE MANAGER

JOHN RICHARDSON
ERGM PAYLOAD
BOB NIEMEYER
USMC WPL
DAVE LIBBON
ONR EUR
LETTITA HARRISON
OSD A&T
JOE BAGNALL

* CONTRACTOR

REVISED - 1/MC/MXCVIII



Panama City

Dahlgren

Fuzes

SABRE

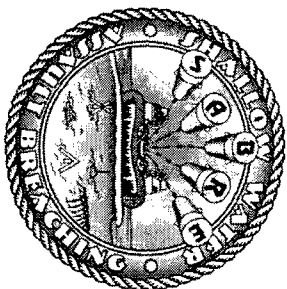

- > **Shallow Water Assault Breaching System**
 - Launched by LCAC
 - Clears mines and obstacles
- > **1,300 lbs of explosives**
- > **Rocket propelled**
- > **400' long**

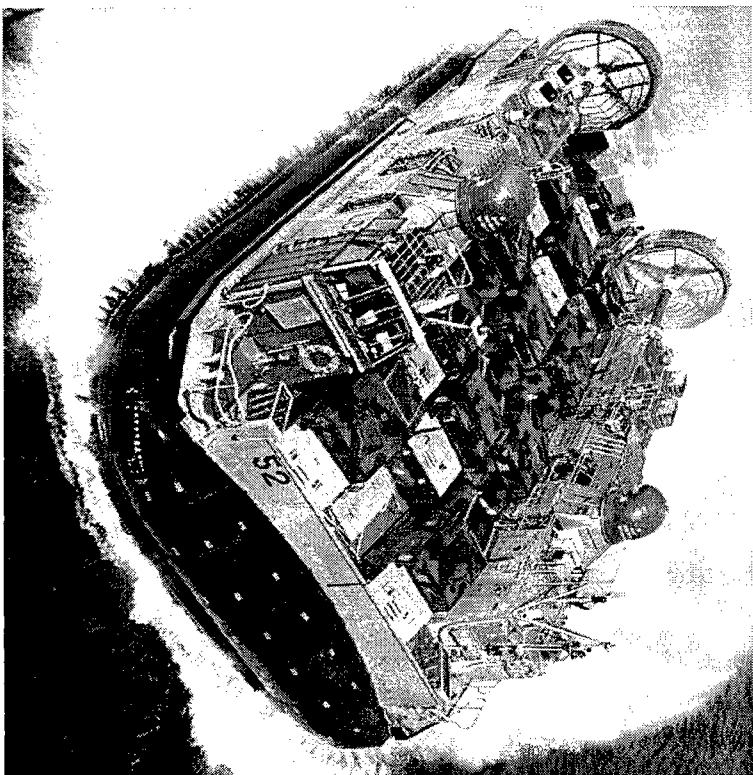



Paramaria City

Dahlgren

Fuzes

SABRE

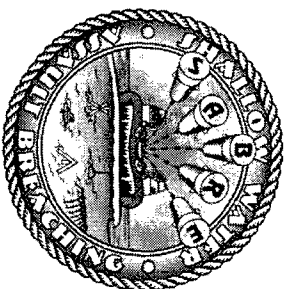

> Meets Safe Separation Requirement - in Water Detonation

- mechanically senses water for arming
- adds delay before
- > Qualification - ong

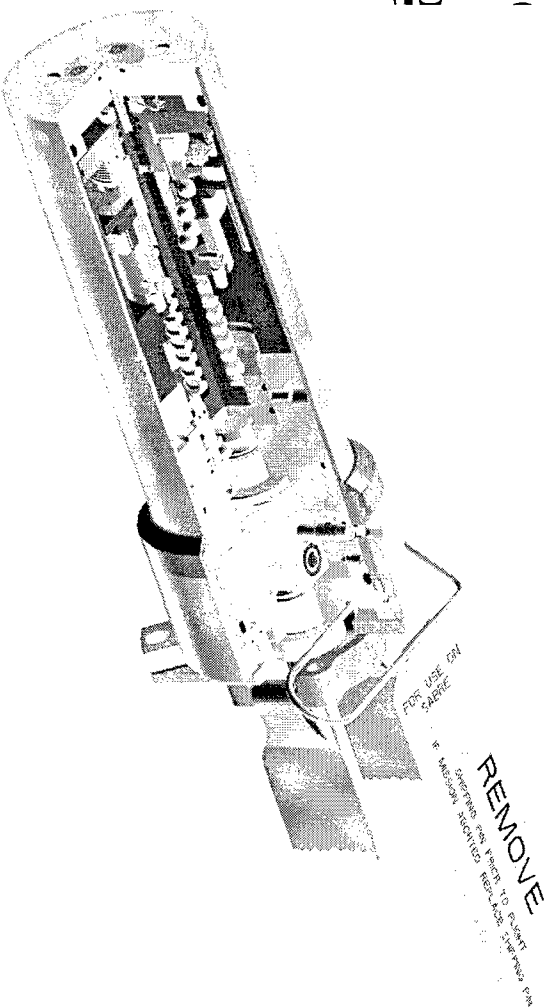



Panama City

Dahlgren

Fuzes

MFF

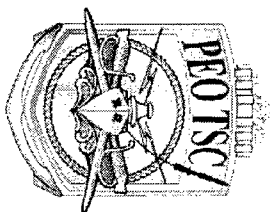

- > Multi-function Fuze for
USN projectiles
- > 5 Operational Modes
 - Anti-Air
 - Surface Proximity
 - Electronic Time
 - Point Detonation
 - Autonomous
- > Inductively Set Message

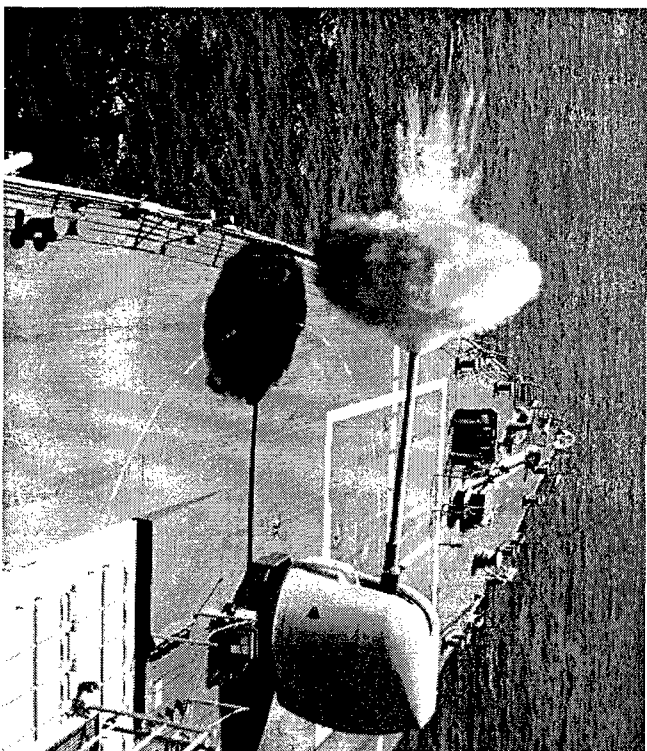



Panama City

Dahlgren

Fuzes

MIF

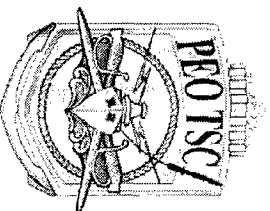

- > Successful transition from Motorola to Alliant
- > Operational Assessment completed aboard DDG75: February 99
 - Analysis ongoing
- > DT/OT: FY99
- > Type Qualification: FY99

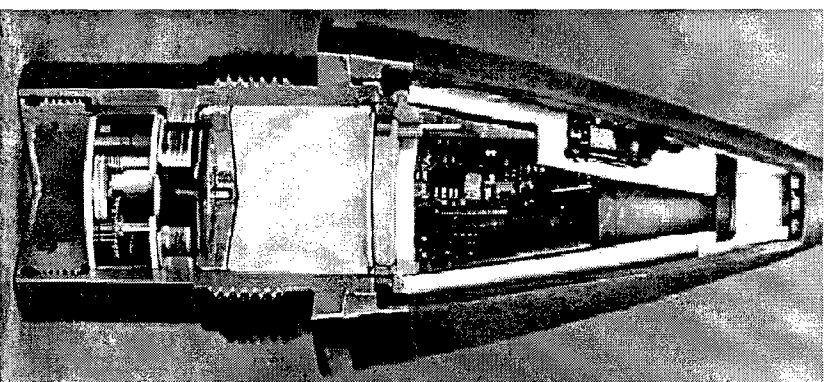



Panama City

Dahlgren

Detonators
SCB

- > Semi-Conductor Bridge (SCB) for USN projectile fuzes
- > All applications where **FEDs** are now used

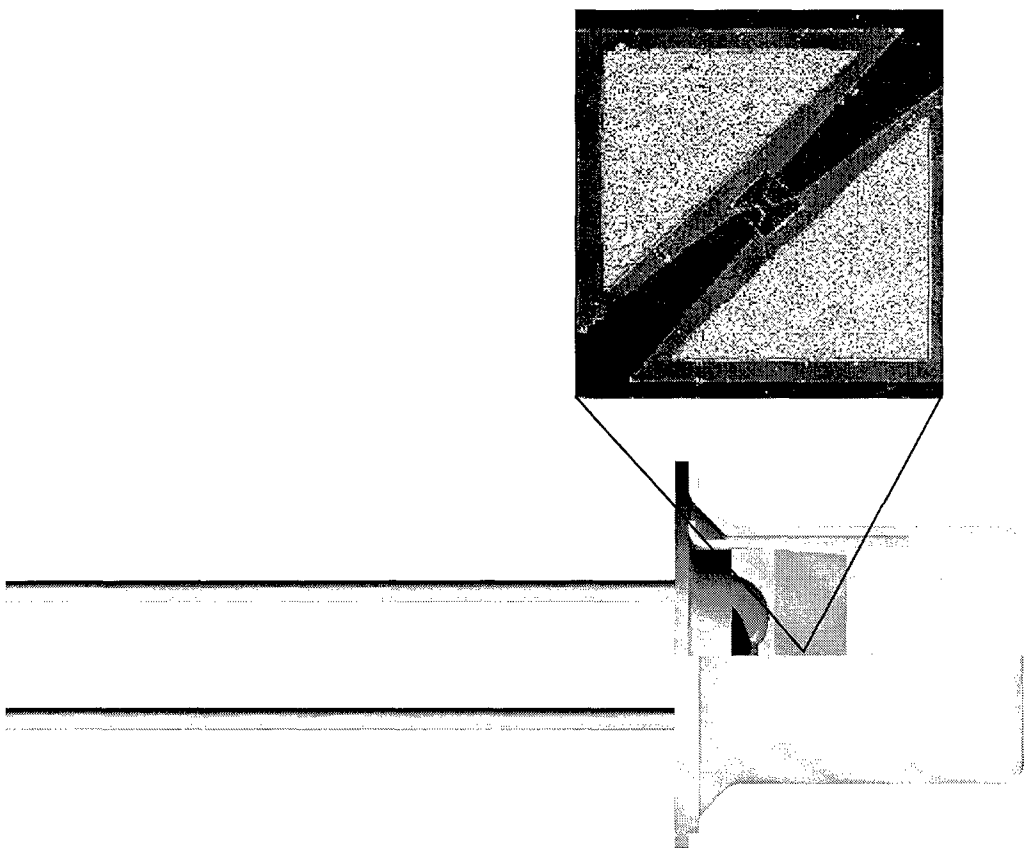



Panama City

Dahlgren

Detonators

SCB

> **Advantages**

- More reliable: ignites faster, less energy
- Less Expensive: mass production possible
- Safer: improved EMI & FSD features

> **Team Members**

- NSWC/DD & Quantic Industries

> **Testing**

- Development: June 99
- Qualification: December 99



Panama City

Dahlgren

Detonators

MK 21 Initiator

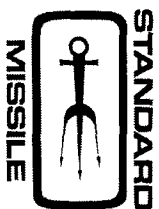

> Slapper Advantages

- promptly initiate secondary explosives

- require a unique high voltage pulse to function
- can be ganged in arrays

> Slapper Disadvantage

- excessive amount of energy required to function reliably

CROSS SECTION OF THE MK21 MOD1 INITIATOR

ER-430 INITIATOR CONCEPT

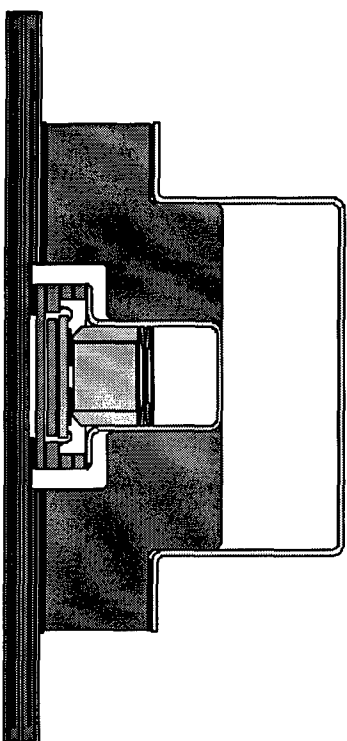



Paranama City

Dahlgren

Signal Processing

Digital Signal Processing

- > Digital Signal Processor with Associated Algorithms for MFF
 - Improved target detection
 - Increase resistance to countermeasures
 - Lower future development costs
- > Wavelet transforms for optimal filtering
- > Rapid prototyping techniques for software development
- > Team Members
 - NSWC Dahlgren, NRL, Alliant Techsystems
- > Incorporate DSP into MFF production contract
 - Qualify changes with production hardware in FY00



Panama City

Dahlgren

Target Detection Devices & Sensors

Multi-Color IR

- > Develop 2 Color IR Detector Array
 - MWIR (plume) & LWIR (hardbody)
 - High Frequency Response
 - Uncooled
 - Low Cost
- > Develop Associated Signal Processing Hardware & Software
 - DSP
 - Algorithms
- > Team Members
 - NSWC Dahlgren
 - Atlantic Aerospace & Fermionics





Panama City

Dahlgren

Target Detection Devices & Sensors *Predator SPRAW*



> Primary Target

- MBTs w/ reactive armor
- Max. range 600m

> Characteristics

- 20 pounds, 34.4 inches long

> Modular Construction

- Inertial G&C, 2-stage solid rocket
- EFP Warhead
- Target Detection Device

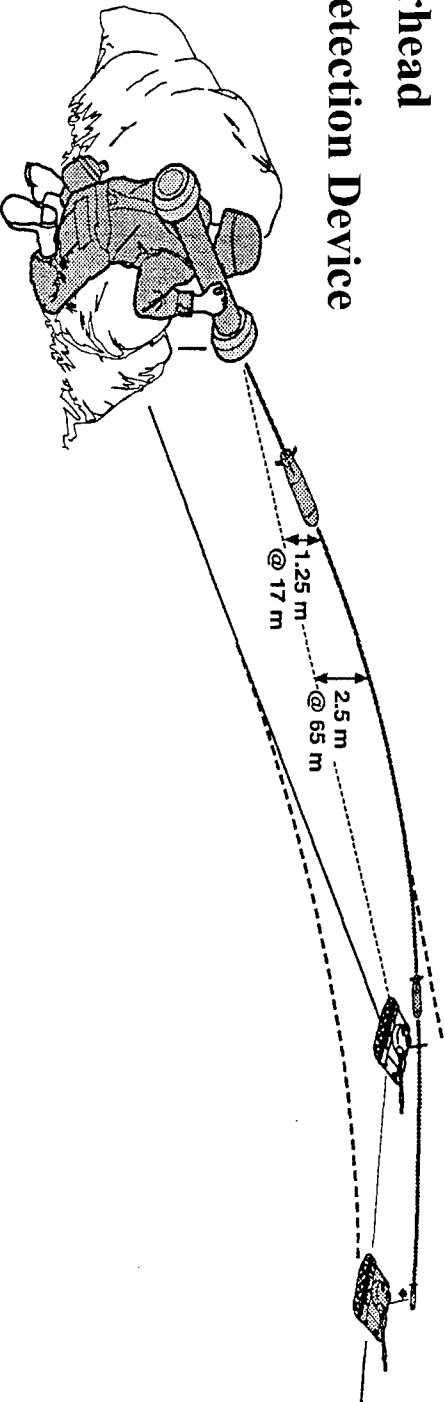
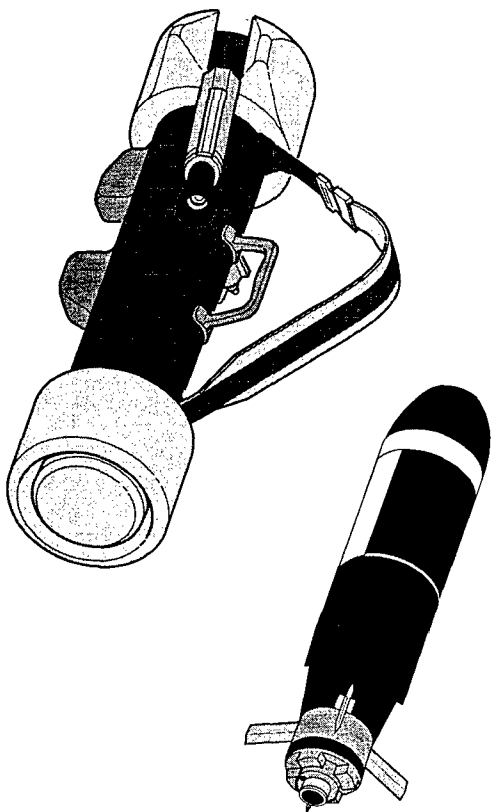



Panama City

Dahlgren

Target Detection Devices & Sensors

Predator SRAM

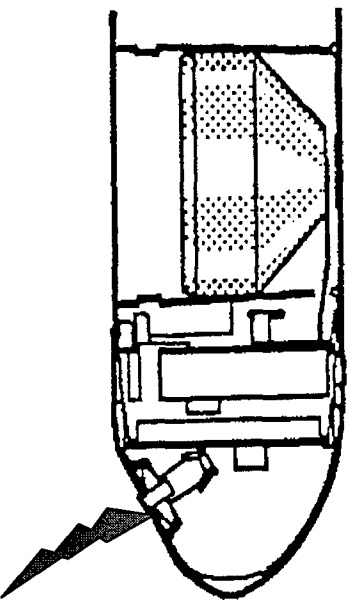

- > **Laser Ranger & Magnetometer coupled to detect AFVs**
- > **Microprocessor employs firing algorithms to determine optimal warhead hit point during missile overflight of target**
- > **All-weather, day & night performance against targets in clear & under CMs (smoke, defilade, netting)**



Panama City

Dahlgren

Target Detection Devices & Sensors
Predator SRAW



- > Predator Target Detection Device
- > Completing Phase II EMD
- > USMC, NSW/CDD (TDA), Lockheed Martin (Prime Contractor)
- > Preparing for OT&E FY00



Panama City

Dahlgren

Modeling

IR Projectile Fuze

- > **Model Complete Fuze-Target Engagement**
 - **Assess Projectile Performance in Lab**
 - **Measure Effects of Engineering Changes**
 - **Trend Performance Degradation**
- > **Model Considerations**
 - **Closing Geometry**
 - **Target Signature**
 - **IR Energy Propagation**
 - **Detector & Circuit Response**
 - **Warhead Lethality**



Panama City

Dahlgren

Modeling IR Projectile Fuze



1. Real Target Data Extracted

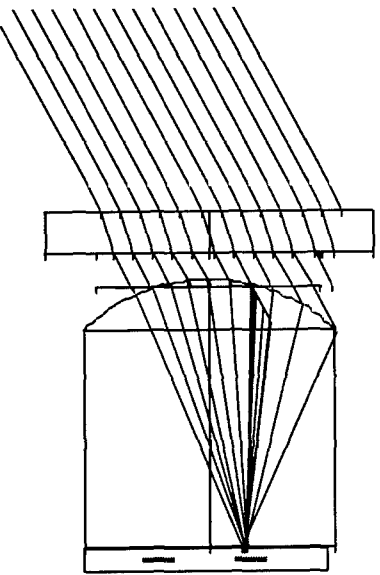

3. Optics Assembly Evaluated

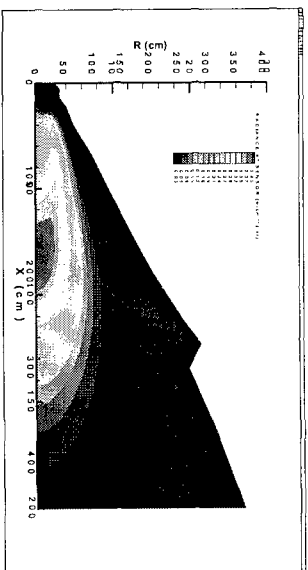

2. Plume Characteristics Generated

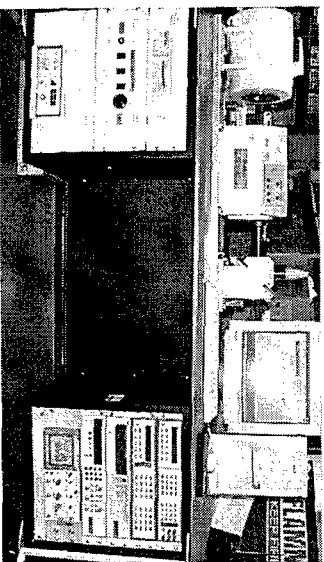

4. Actual Fuze Performance Assessed



Panama City

Dahlgren

Power Supplies *Common Battery for Projectile Fuzes*

- > Reserve Battery for All Electronic USN
Projectile Fuzes
 - MFF, MK 404, MK 418 & MK 417
- > Replace Lead-Acid Chemistry
- > Adopt MOFA-like Design
- > Team Members
 - NSWC Dahlgren
 - ARDEC
 - Alliant Techsystems



Power Supplies Common Battery for Projectile Fuzes

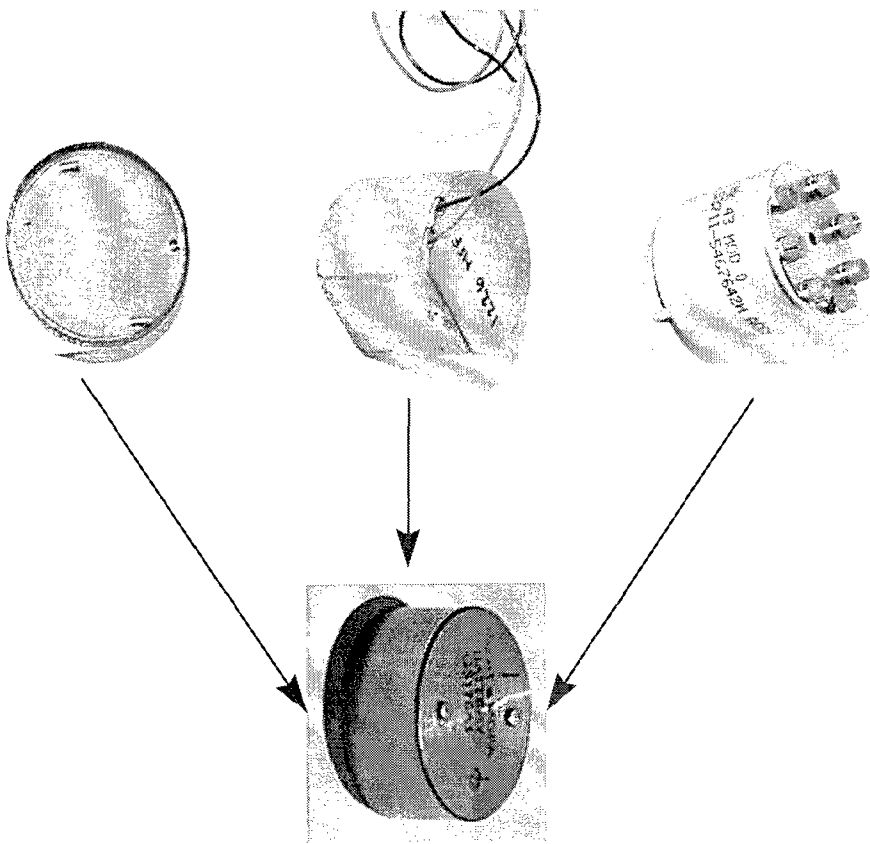

- > MOFA-like
 - Same external dimensions
 - Most parts identical
 - Same production line
- > May Meet MOFA Cost & Performance Requirements
- > Challenges
 - Current & Rise Time



Panama City

Dahlgren

Safe & Arm Devices

ERGM

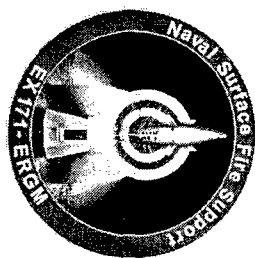

Dispense

Flex Cable

Piston
Actuator

Dispense Initiator

Rotor with
Detonator

Setback
Mechanism
Position

Detonator Output to Ignite
Expel Gas Generator

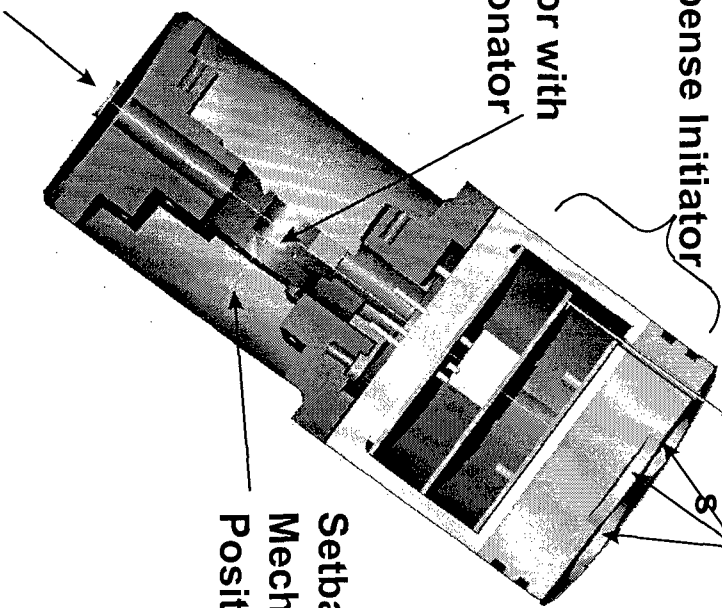

- > Electro-Mechanical Assembly for Arming & Firing Payload Expel & Dispense Gas Generators
- > Coded Signal from Guidance Electronics Initiates Expel & Dispense Events:
 - Pattern Size Information Downloaded Prior to Launch
 - One to Three Dispense Gas Generators Fire Depending on Pattern Size



Panama City

Dahlgren

Safe & Arm Devices

ERGM

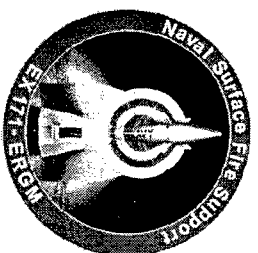

- > In Engineering & Manufacturing Development
- > Testing Ongoing
- > Team Members
 - NAVSEA (PMS429)
 - NSWC Dahlgren
 - KDI
 - Raytheon



Paranama City

Dahlgren

Fuzed Payloads

5"/54 Cargo & ERGM

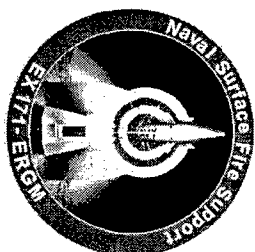

- > Integrate M80-like Submunition into 5"/54 Cargo & ERGM payloads
 - Safety Issues: Inadvertent Expulsion
 - Performance: P3I for effectiveness
 - Production line commonality with Army
- > Team Members
 - NAVSEA (PMIS429)
 - NSWC (Dahlgren, Crane & Indian Head)
 - ARDEC & ARL
 - Raytheon
 - KDI

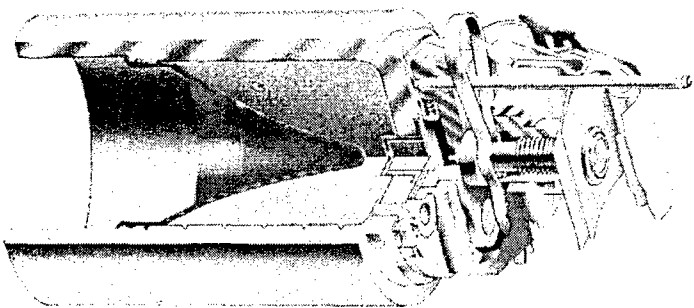



Panama City

Dahlgren

Fuzed Payload **Non-lethal Payloads** *for ERGM*

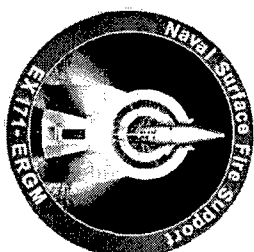

- > **Non-lethal Payloads**
 - Provide precision non-lethal effects
- > **Team Members**
 - Joint Non-lethal Directorate
 - Raytheon
 - NSWC Dahlgren
- > **Possible Payloads:**
 - Calmatives
 - Combustion Modifiers
 - Acoustic Energy
 - Pyrotechnic Strobe/Whistle
 - Sting Balls
 - Ball Bearings
 - Flash/Bang
 - Smoke/Obscurants



Panama City

Dahlgren

Fuze Related Systems *Targeting Devices for Smart Fuzes*

- > Target Location, Designation and Hand-off System (TLDHS)
- > Completing Phase II EMD
- > Army - Lead, USMC, PM-NV/RTSA, NSW/CDD
- > Major Components
 - Lightweight Laser Designator Rangefinder (LLDR)
 - Rugged Handheld Computer (RHC)
 - Target Hand-off Software (THS)





Panama City

Dahlgren

Fuze Related Systems *Targeting Devices for Smart Fuzes*

- > TLDHS enables observers to quickly & accurately
 - Acquire/locate targets
 - Digitally transmit requests for fire support (precise coordinates):
 - Field Artillery
 - Close Air Support
 - Naval Surface Fire Support
 - Designate targets for laser-guided munitions & laser spot trackers

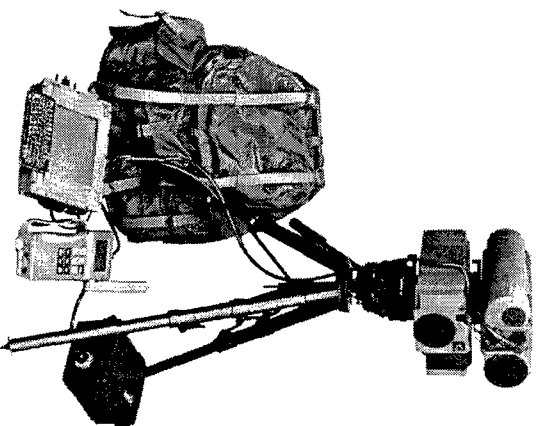

Transitioning RFID/MEMS Technology to Meet the Warfighter's Needs

NDIA Fuze Conference

CAPT John J. Walsh

NSWC Indian Head Division

7 April 1999



Current Projects

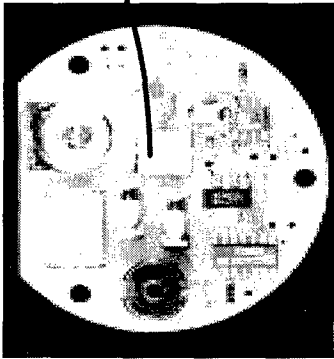
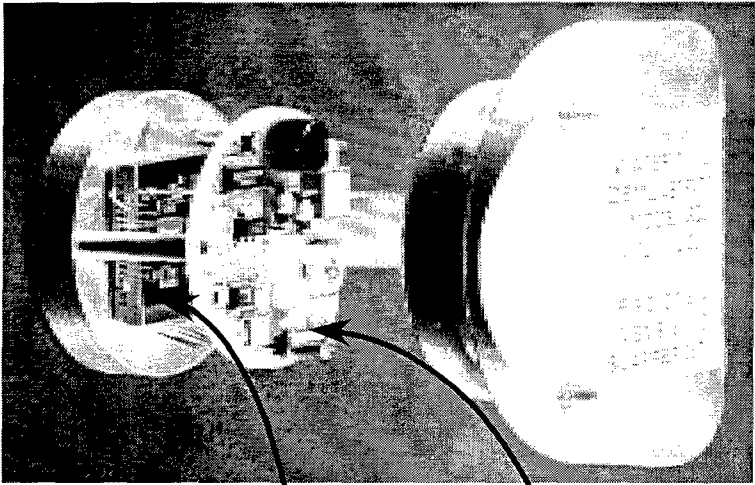

MEMS S&A Fire-set

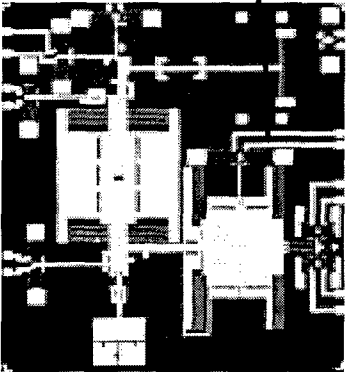

LIGA S&A Chip

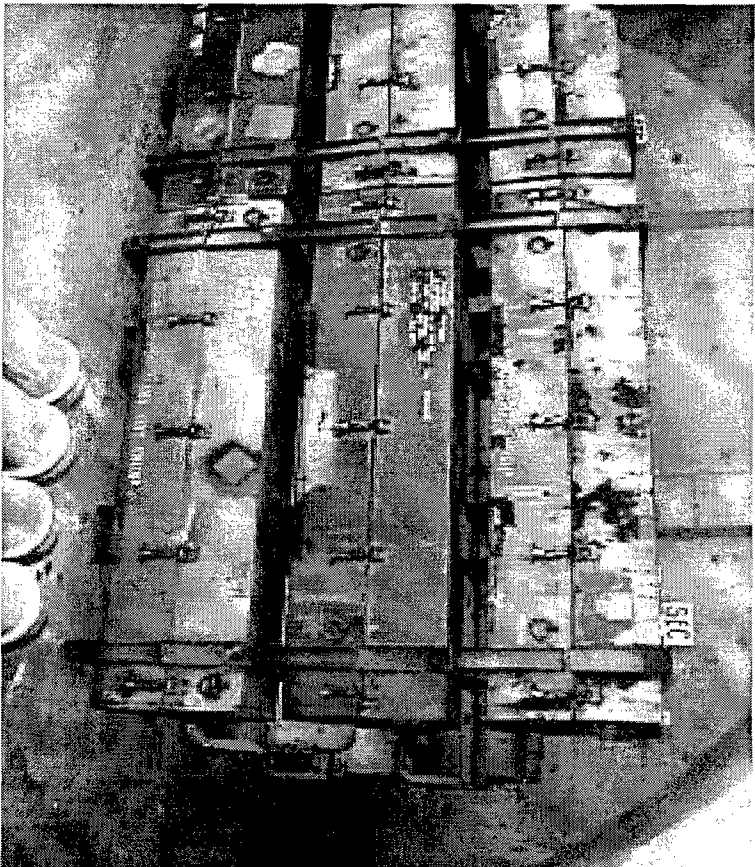

- What Indian Head is doing NOW



Fleet Realities

- Errors in Ordnance Inventory
- Manual Process-Need real-time Inventory
- Personnel reductions require “hand’s off” solution
- ROLMS and CAIMS databases

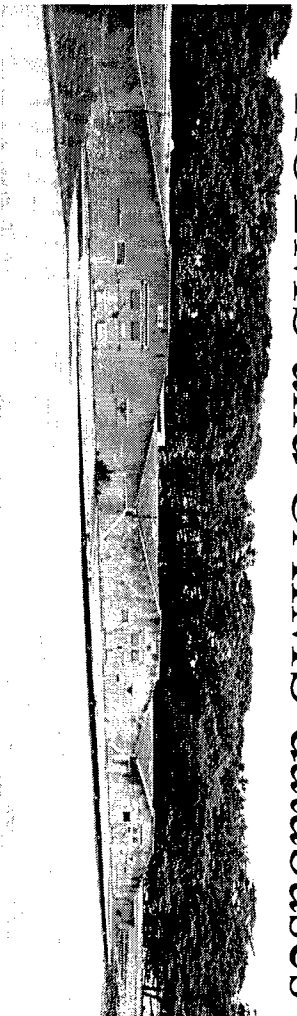

• We must do better for the Warfighter



Predictive Technology

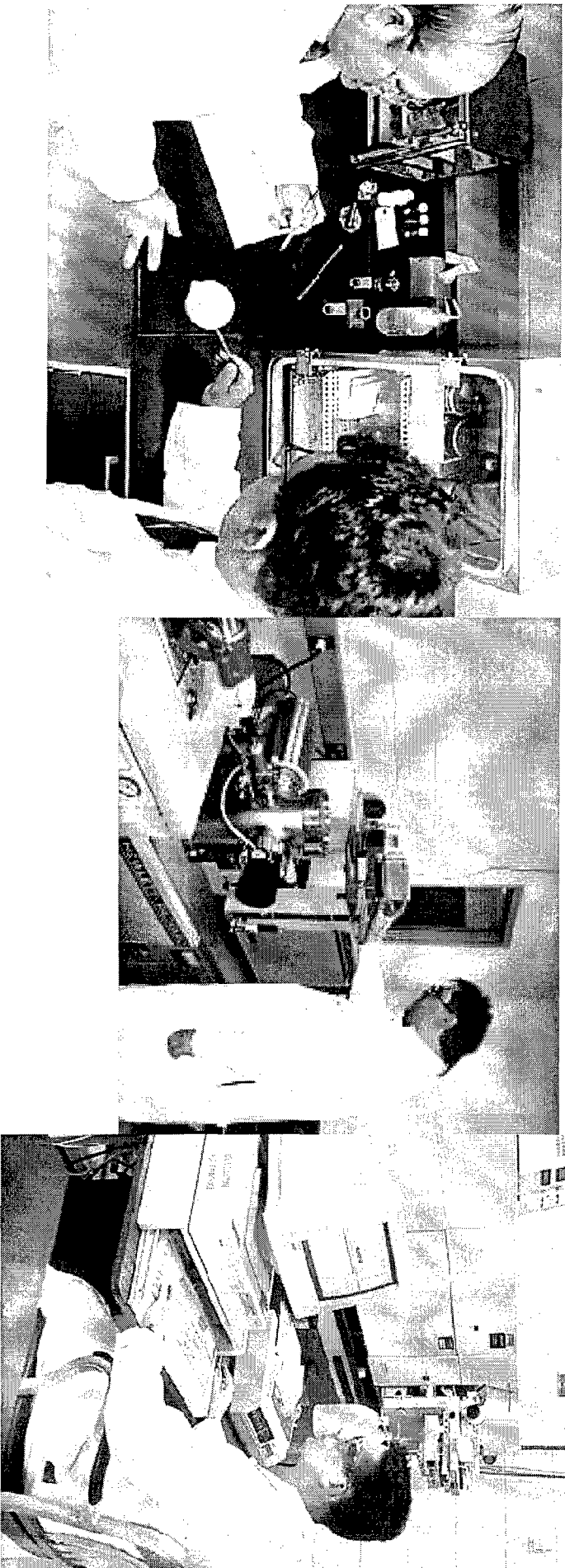

- Reduce Total Ownership Cost for DoD

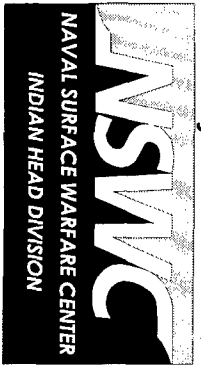

RFID Ordnance Inventory/Surveillance System

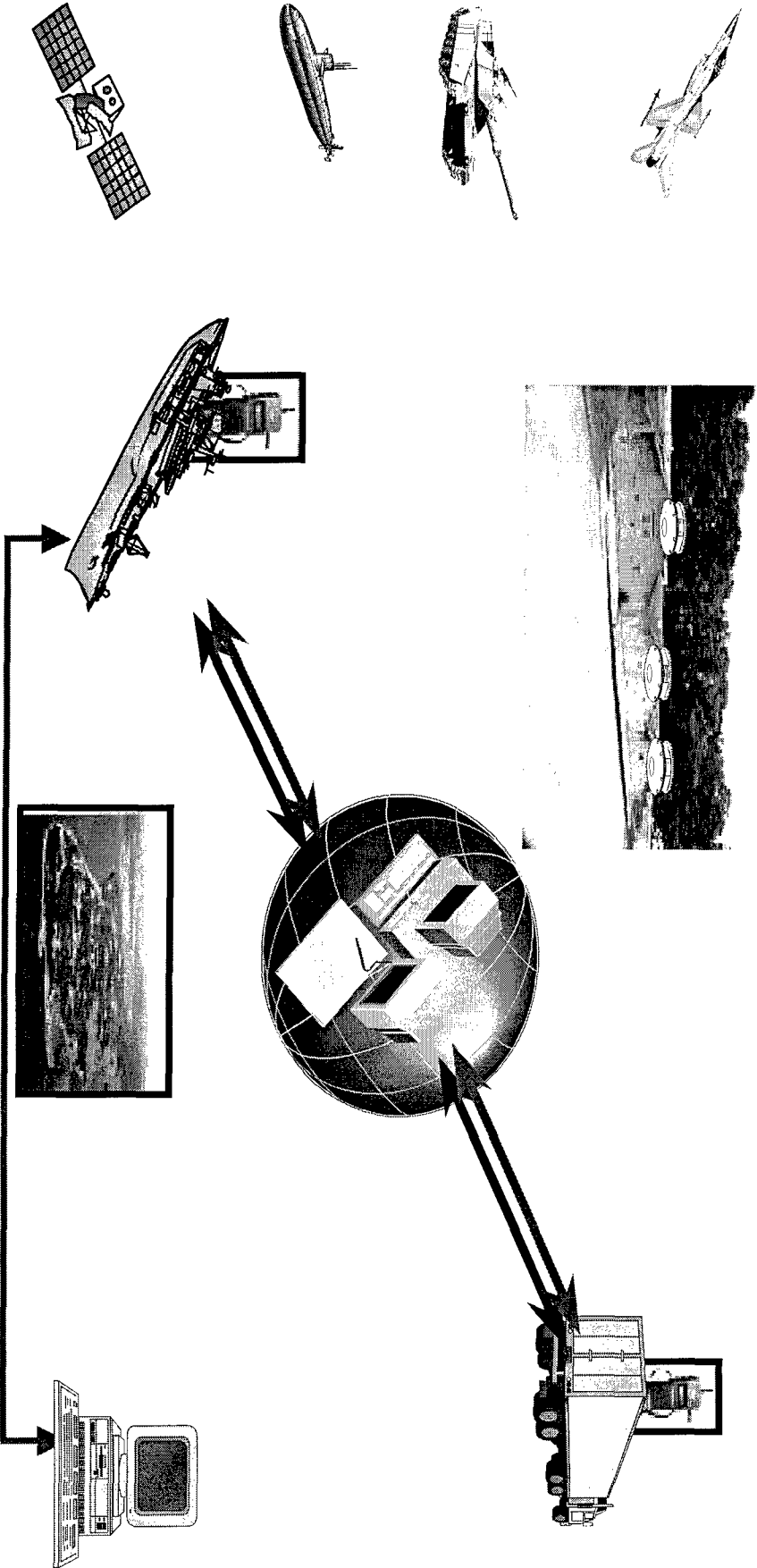

- Revolutionary Change in Ordnance Logistics



Fleet Logistics Stakeholders

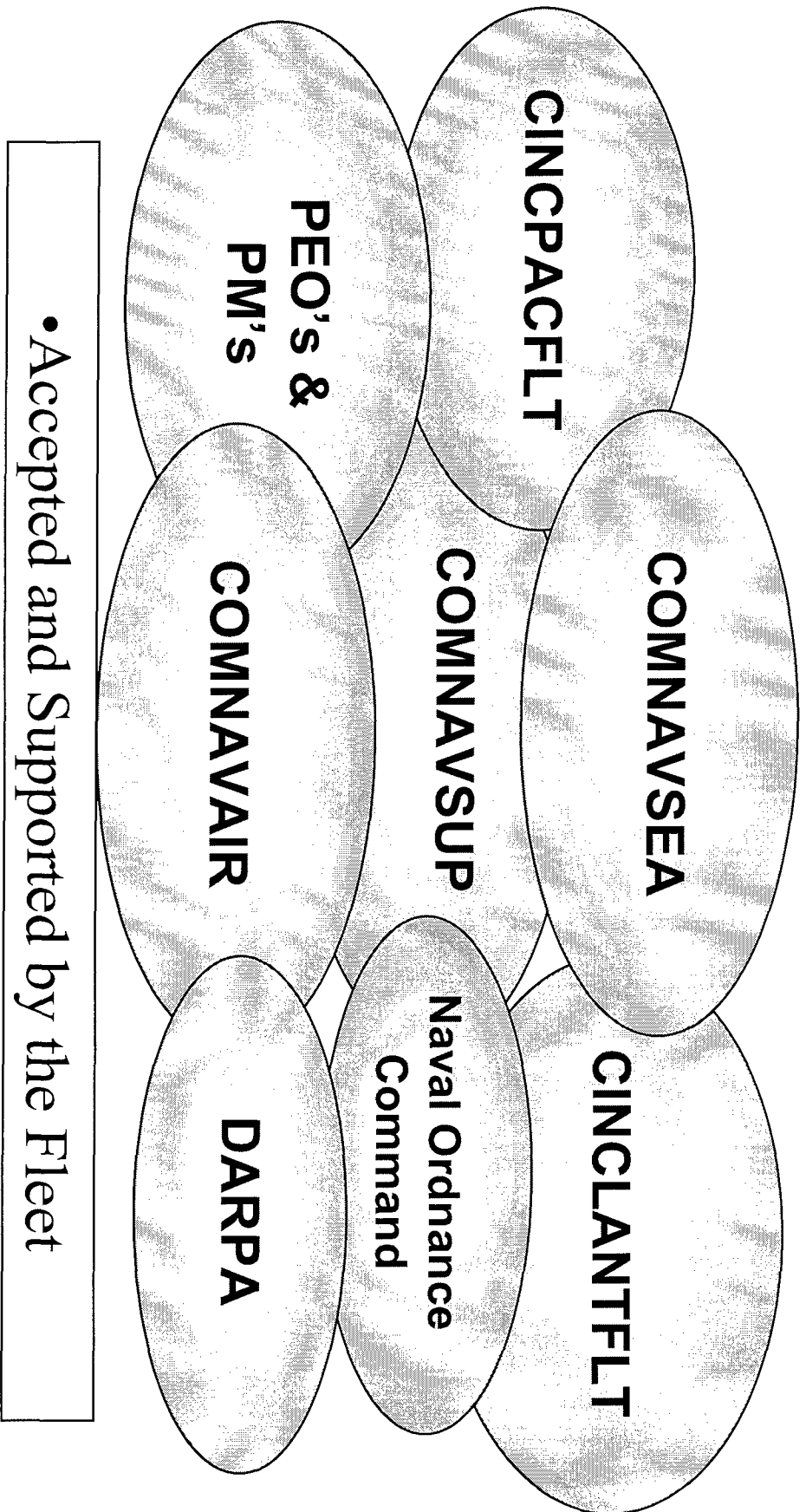



Related Areas

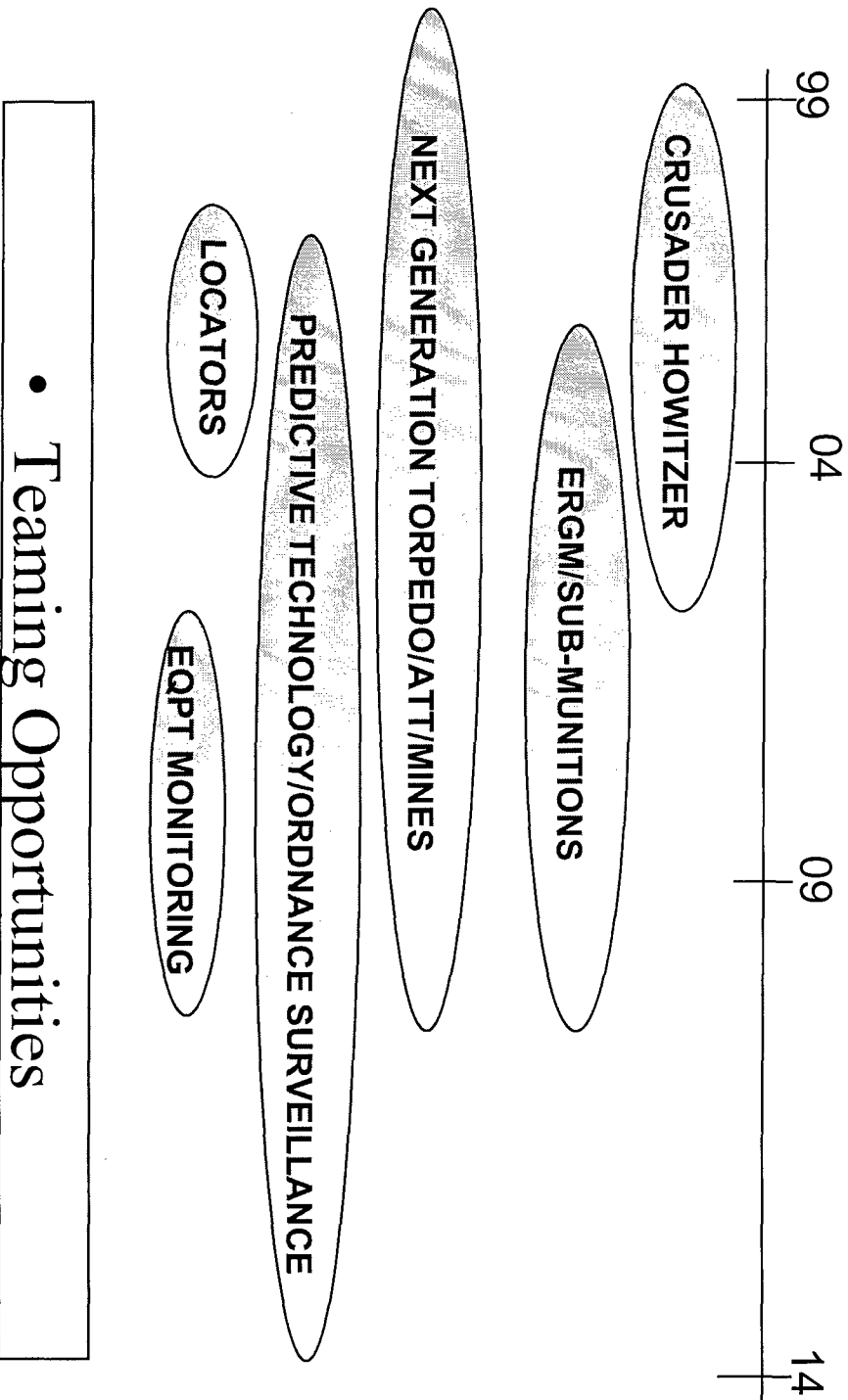



The Bottom Line

- RFID Ordnance Inventory/Surveillance is \$43M program with majority of work for industry
- Calculated ROI to the Fleet, 26 to 1
- Majority of the effort is in Private Enterprise
- MEMS technology insertions required

• What does this mean to you?



Wrapup

- Indian Head POCs present:
 - CAPT John Walsh, 301-744-4401, WalshJJ@ih.navy.mil
 - Paul Smith, 301-744-6288, SmithPJ@ih.navy.mil
 - Ed Litcher, 301-744-6288, Litcher@ih.navy.mil
 - Matt Beyard, 301-744-4331, BeyardMC@ih.navy.mil
- Predictive technology POCs
 - Rich Low, 301-744-6489, LowRJ@ih.navy.mil
 - Gail Stine, 301-744-6715, StineGY@ih.navy.mil
- IHD web site: www.ih.navy.mil

• Indian Head, RFID/MEMS Technology Transfer for the Fleet

Innovations In Proximity Fuzing



Mr. David Lawson
Project Engineer, Proximity Fuzes
KDI Precision Products, Inc.



**43rd Annual
Fuze Conference**
"Fuzing Challenges:
Opportunities to Excel"

**Munitions Technology
Symposium VI**
hosted by "Munitions Manufacturing
and Technology Section"

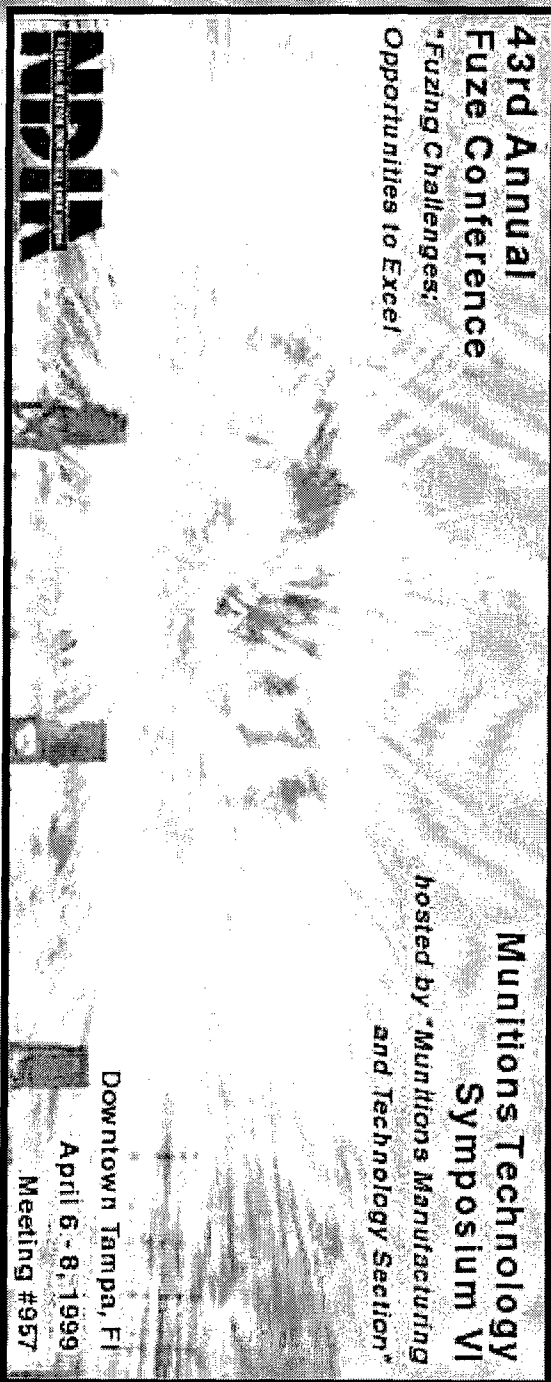

Downtown Tampa, FL
April 6 - 8, 1999
Meeting #957



Mr. Telly Manolatos

V.P. of Engineering
Electronics Development Corp.



Mr. Ron Wardell

Senior Design Eng./ Tech. Project Officer
TACOM-ARDEC Fuze Division



OUTLINE

- **DDR Overview**
- **Signal Processor History**
- **M734A1 Program Summary**
- **M734A1 Ballistic Results**
- **Multi-Use Signal Processor Development**
- **Development Team**
- **Technical Design**
- **Applications**
- **Summary**





DDDR OVERVIEW

- **FM/CW Ranging System**
 - ❖ Discriminates Frequency Information Instead of Amplitude Information From FM/CW Transceiver
 - ❖ Provides Increased Accuracy of Height-of-Burst (HOB)
- **Dual Channel Directional Doppler Ranging (DDDR) Signal Processor**
 - ❖ Discriminates Between Approaching and Receding Doppler
 - ❖ Provides Noise Immunity From Internal or External Sources
 - ❖ Highly Integrated, Single Chip Signal Processor Solution
 - ❖ Mixed Signal IC
 - ❖ All Timing Derived From Single Clock



EDC SIGNAL PROCESSOR HISTORY

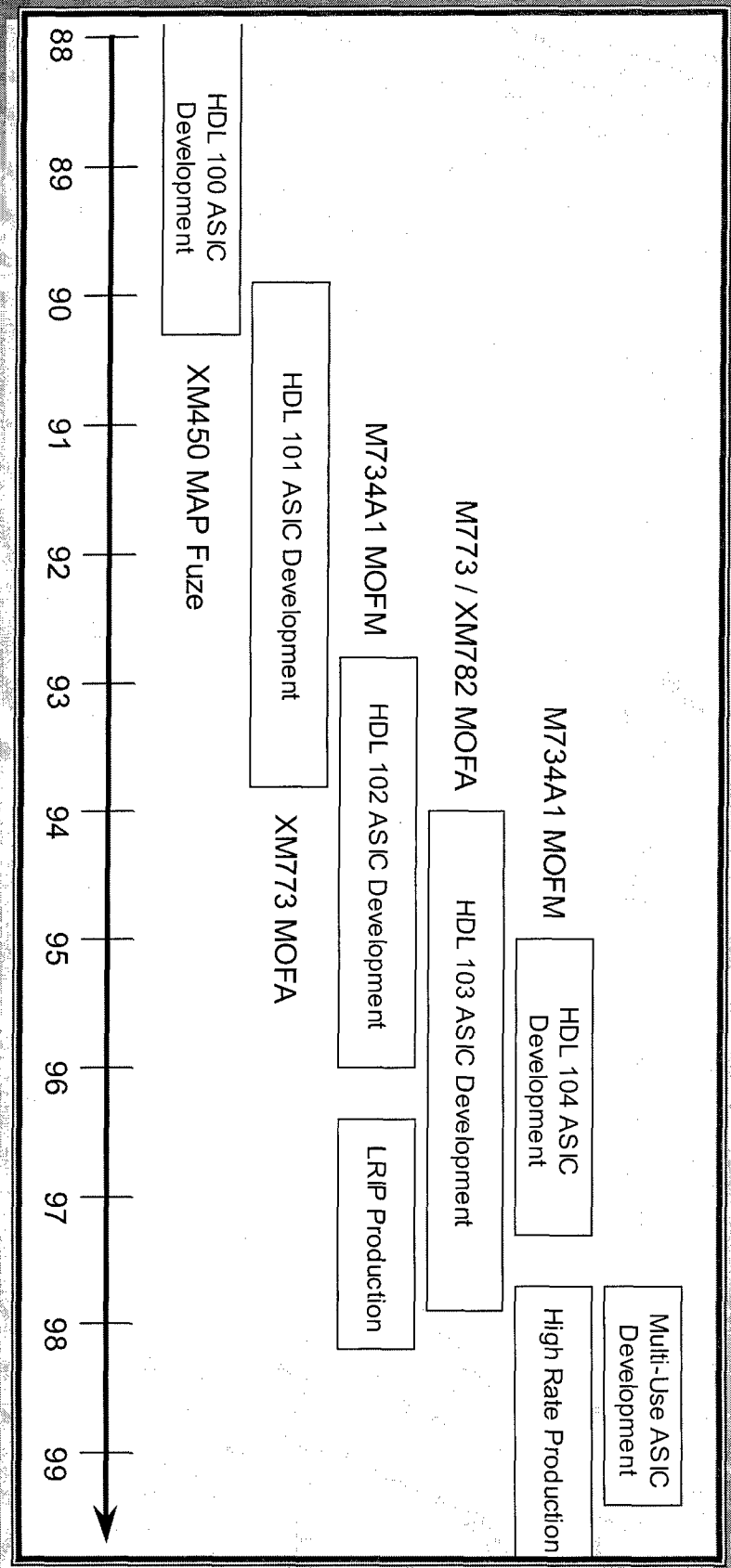



M734A1 PROGRAM SUMMARY

➤ **Type Classification**

June 96

➤ **Task III - LRIP**

FAAT Sep 97

✦ 9,000 Fuzes: Lots 1 - 3 Complete

Sep 97 - Apr 98

➤ **1st Production Contract**

FAAT Jan 98

✦ 78,456 Fuzes: Lots 2 - 10 Complete

April 98 - Jan 99

✦ 26,133 Fuzes: Lots 11 to 12 In-process

Feb 99 - March 99

➤ **2nd Production Contract**

Multi-year

✦ 46,800 Fuzes: Lots 1 to 5 In-process

June 99 - Oct 99



M734A1 BALLISTIC RESULTS **60MM & 81MM MORTAR TESTS**

➤ L RIP and Production Ballistic Results Conducted
 Yuma Proving Grounds

- ◆ Number 903
- ◆ Mean 7.53
- ◆ Std. Dev. 0.948
- ◆ Min. 3.88
- ◆ Max. 10.17

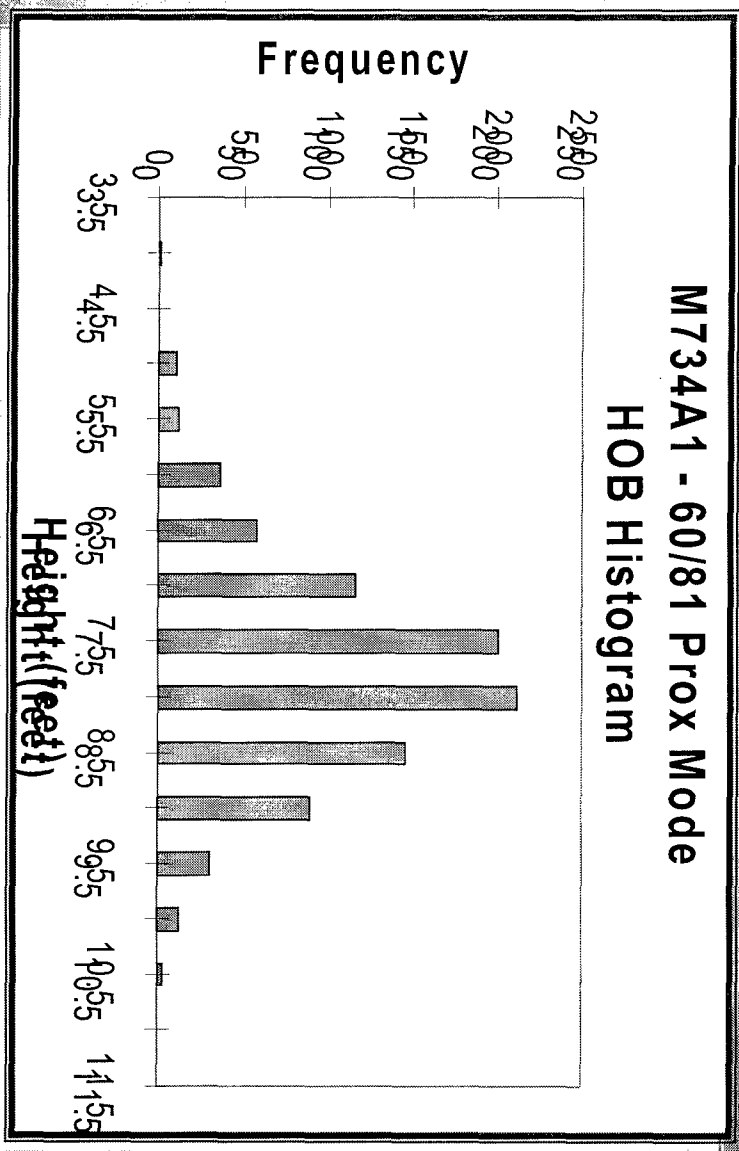

M734A1 BALLISTIC RESULTS **120MM MORTAR TESTS**

➤ LRIP and Production Ballistic Results Conducted
 Yuma Proving Grounds

- ✧ Number 725
- ✧ Mean 14.47
- ✧ Std Dev 2.748
- ✧ Min 6.19
- ✧ Max 20.0

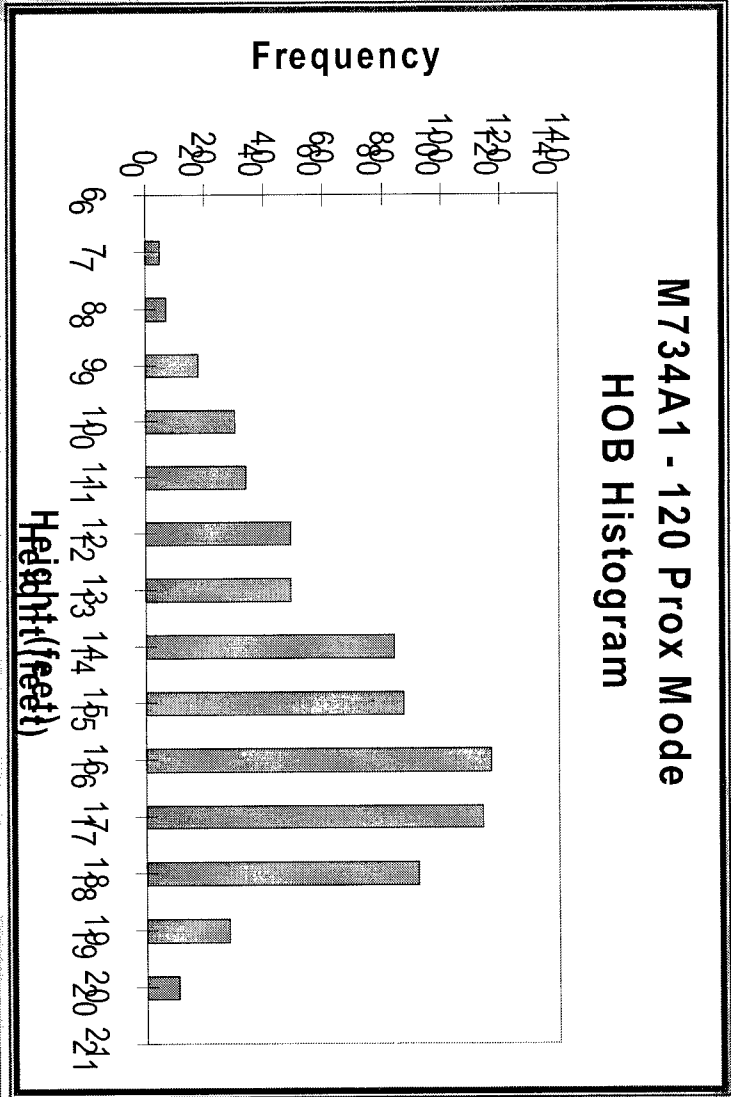



MULTI-USE SIGNAL

PROCESSOR DEVELOPMENT

- KDI Initiated IRAD Program Started Oct 97
- EDC Lead Design of New Signal Processor ASIC
- CRADA Established With ARDEC Fuze Division In Adelphi
- Program Team Organized To Develop New ASIC
- First Prototypes Delivered July 98
- Second Iteration of Mask Set Started
- Second Prototypes Delivered March 99



EDC | MULTI-USE SIGNAL PROCESSOR DEVELOPMENT TEAM

Company	Member	Role
EDC	Telly Manolatos	Team Leader
EDC	John Gautz	Test & Evaluation
EDC Consultant	John David	System Design
KDI	Tom Nickolin	IRAD Manager
KDI	David Lawson	Project Engineer
KDI	Bob Hertlein	RF Engineer
ARDEC Fuze Division	Ron Wardell	CRADA / Consultant
Univ. of Florida	Marion Bartlett	System Design / Consultant
ICS	George Warren	ASIC Design





TECHNICAL DESIGN OVERALL BLOCK DIAGRAM

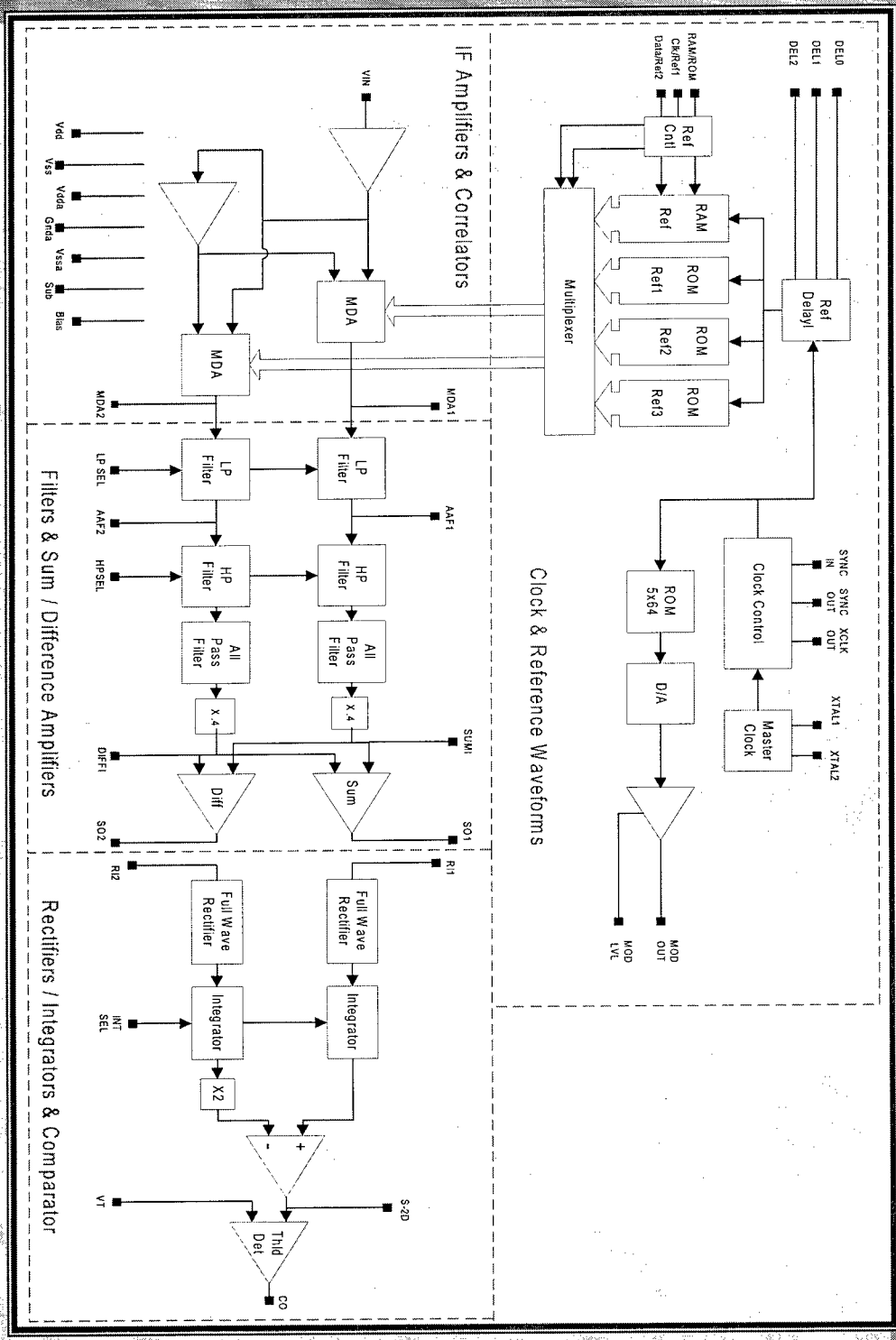



TECHNICAL DESIGN

CLOCK AND REFERENCE WAVEFORMS

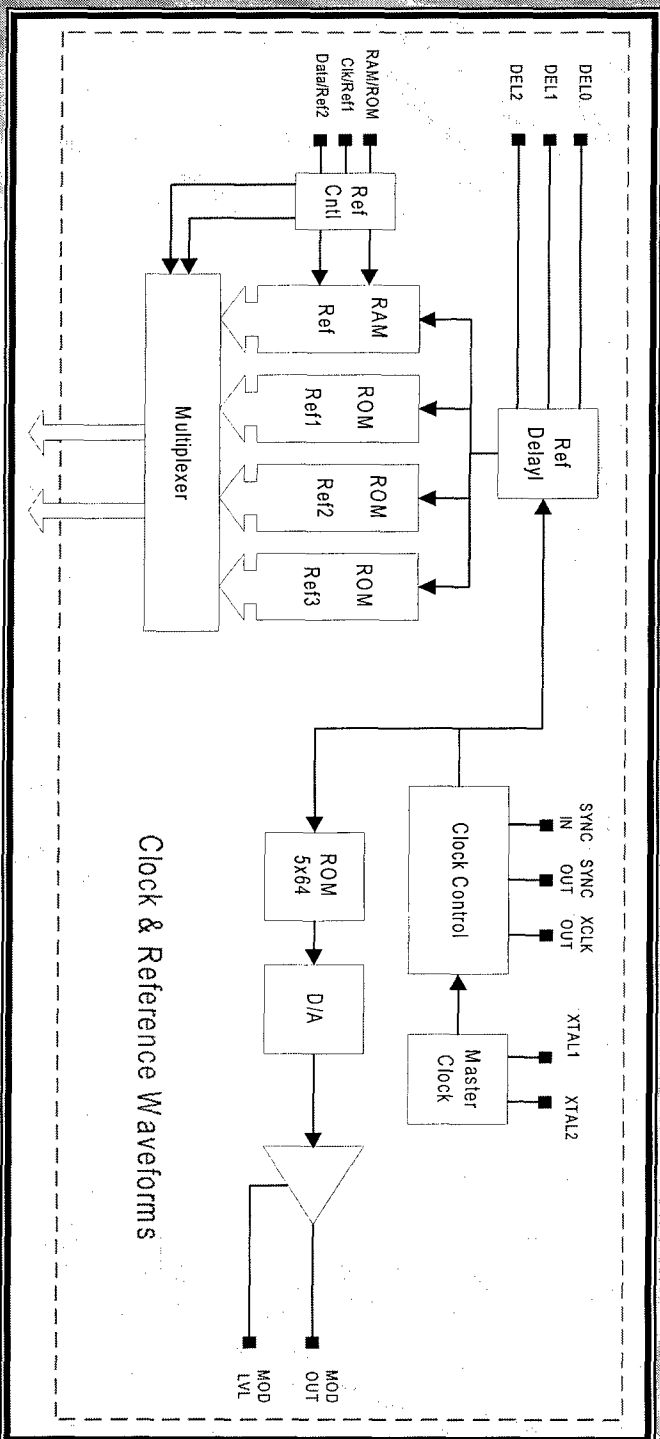

- Three Pairs Of Preprogrammed Waveforms
- One Pair Of Programmable Waveforms
- Selectable Reference Waveform Delay
- Transmitter Modulation Output And Level Control
- Clock Circuitry



TECHNICAL DESIGN

IF AMPLIFIERS AND CORRELATORS

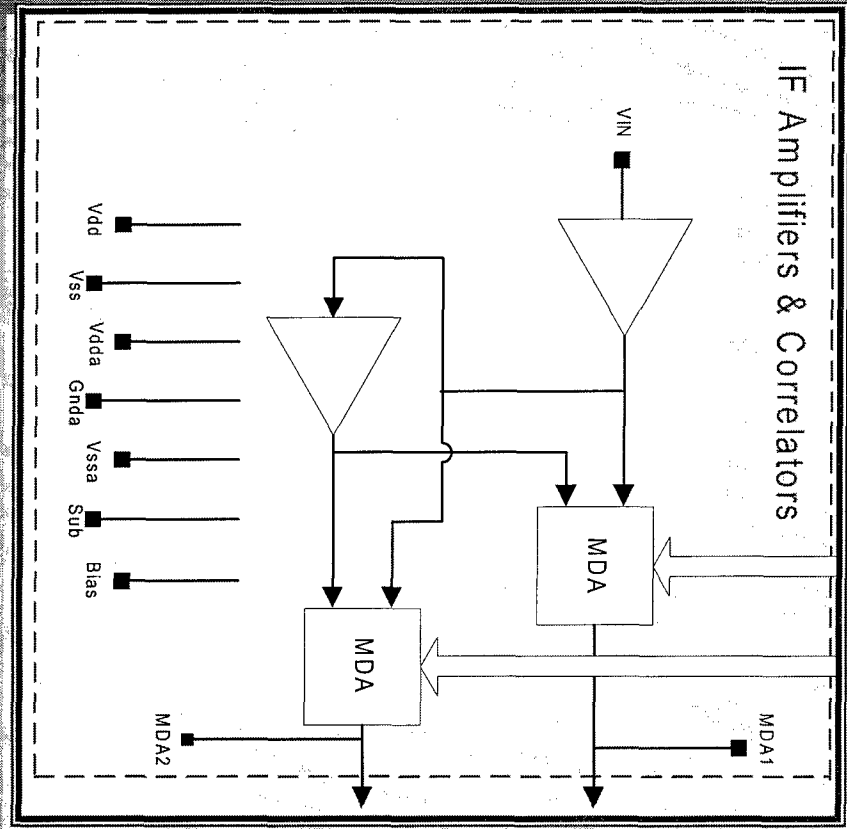

- Dual Channel IF Amplifiers
- Dual Channel Correlators



TECHNICAL DESIGN

FILTERS AND SUM / DIFFERENCE AMPLIFIERS

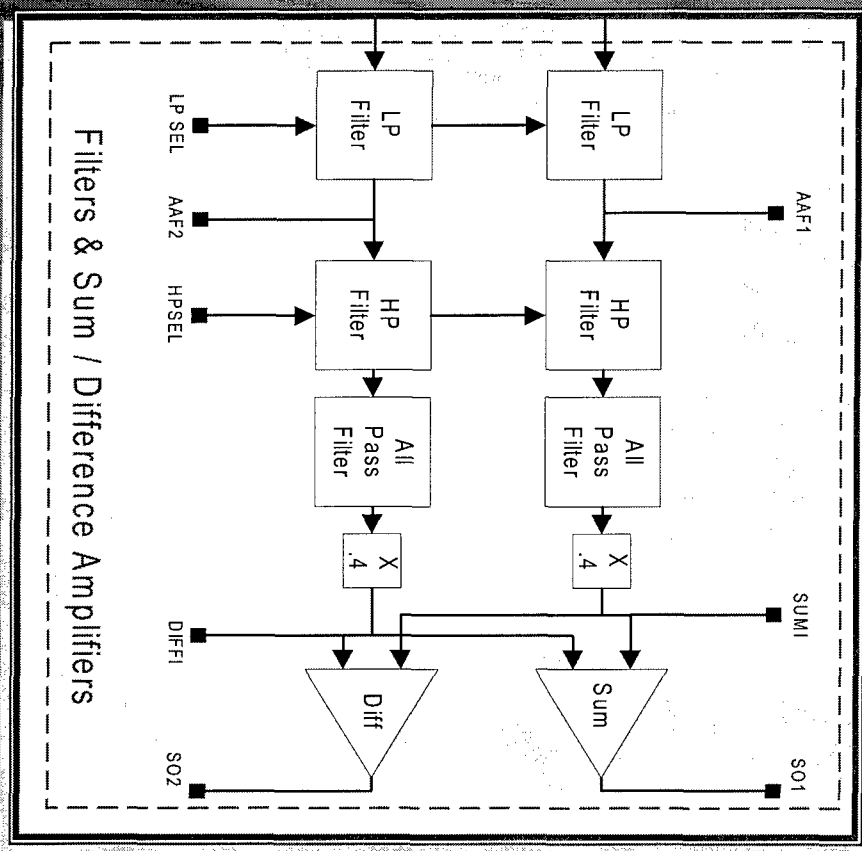

Filters & Sum / Difference Amplifiers

- Dual Channel Selectable Corner Frequency Lowpass Filter
- Dual Channel Selectable Corner Frequency Highpass Filter
- Dual Channel All Pass Filter
- Sum and Difference Amplifiers



TECHNICAL DESIGN

RECTIFIERS / INTEGRATORS AND COMPARATOR

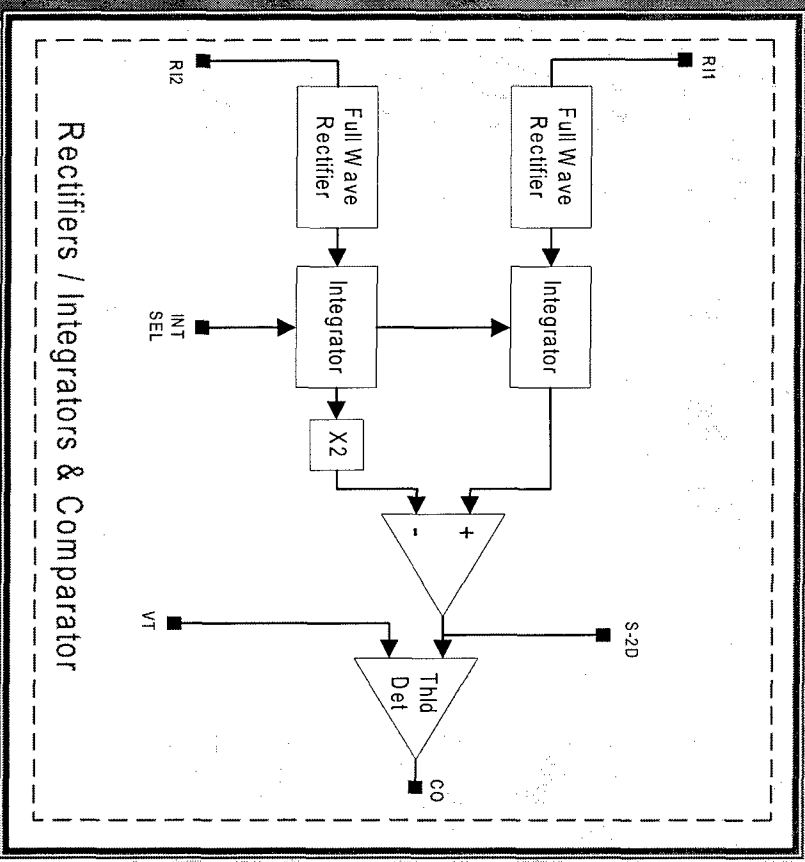

- Dual Channel Rectifiers
- Dual Channel Integrators
- S-2D Summing Amplifier
- Variable Threshold Comparator





APPLICATIONS

	Target Type			Custom
	Ground	Cargo	Air	
HOB / Range (ft)	5 - 50	750 - 1000	5 - 50	Any Combination Of Target Types And HOB Selectable At Time Of Launch
Typ. Accuracy (%)	20	10	20	
Velocity (ft/s)	60 - 1900	125 - 1900	125 - 3800	
Systems	Mortar	Artillery	Artillery	Mortar
	Artillery	Missile	Missile	Artillery
	Bomb			Bomb
				Missile

Note: Velocity range can be tailored by changing the RF frequency and master clock frequency.





SUMMARY

MULTI-USE SIGNAL PROCESSOR

- Successful "Partnering"
- FM/CW Directional Doppler Ranging Signal Processor
- Multiple Target Applications - Ground, Cargo & Air
- Customizable for New Applications
- Adjustable Height-of-Burst
- Accurate Height-of-Burst
- ECM Hardened
- Mature Technology
- State-of-the-Art Design

◆ AFFORDABLE

◆ PRODUCIBLE

◆ RELIABLE



Processing of Energetic Materials at Thiokol's 19mm Twin Screw Extrusion Facility

Andrew C. Haaland, Quinn Barker, and Michael T. Rose
Thiokol Propulsion, a Division of Cordant Technologies
Brigham City, Utah 84302-0707

Abstract

A 19mm, 25 l/d twin screw extrusion (TSE) facility has been built and used for processing energetic materials. The extruder is equipped with four independent temperature control zones, segmented screws, a jacketed die block capable of accepting various dies, and a remote control capability. The facility has been equipped with loss in weight (LIW) feed systems for raw material handling and has vacuum capability. Data monitoring capabilities include melt temperature and pressure, torque, screw speed, and temperatures in all of the control zones. A variety of post processing equipment has also been designed and fabricated for use in manufacturing various different extrudate geometries. A summary of extruder design considerations, facility issues, and lessons learned in operating the extruder during the processing of various energetic material formulations will be discussed in this paper.

Introduction

Thiokol Corporation has been involved in the development of twin screw extrusion technology since the early 1980's. Beginning in 1982, a company funded IR&D program was initiated to evaluate process requirements for the production of LOVA gun propellant. This project marked the start of over \$3M in R&D and capital expenditures made by Thiokol to support continuous processing of energetic materials in a 58mm twin screw extruder (TSE) at the Longhorn Army Ammunition Plant (LAAP). As a result of the initial program, twin screw extrusion was found to offer significant technical advantages over batch processing of energetic materials in the areas of safety, environmental issues, product quality, cost reduction, and processing flexibility.

The Thiokol LAAP extrusion facility utilized a Werner & Pfleiderer (W&P) ZSK-58EH split barrel twin screw extruder for the processing of energetic materials. The design of this machine evolved as a result of extensive evaluation of early modular barrel twin screw extruders at NSWC Indian Head, Massachusetts Institute of Technology, NSWC White Oak, ICT Fraunhofer Institute, and Thiokol LAAP. Detailed hazards analysis specific to energetic materials production were conducted on these modular barrel extruders which identified significant potential safety hazards with existing extruder designs. Results of these safety analyses and extensive safety testing including full scale ignition tests of a modular barrel extruder loaded with energetic material led to specific design requirements for an extruder optimized for production of energetic materials. A joint design effort between LAAP and W&P was initiated which resulted in the split barrel extruder design designated ZSK-58EH with specific features and safety enhancements to allow processing of energetic materials. A ZSK-58EH TSE was fabricated and installed at LAAP during the mid 1980's. This extrusion facility began processing energetic materials in 1989³.

Thiokol LAAP demonstrated the use of 58mm twin screw extrusion technology during the execution of several different energetic material programs during the late 1980's and early 1990's^{4,5}. Formulations produced with this processing technology included propellants, explosives, and pyrotechnics. Not only were the basic mixing and extrusion issues related to the production of each type of formulation quantified, but valuable system design information was gathered and improvements were made to the ancillary equipment and processes that support the overall manufacturing technology. Methods suitable for feeding both liquid and solid raw materials, for addition and removal of solvents to in-process material, and for waste minimization were also developed. Table 1 below lists the types, formulations, and quantities of the energetic materials that have been produced using the 58mm TSE.

Approved for public release, unlimited distribution.

1999 Thiokol Propulsion, a division of Cordant Technologies

Table 1. Energetic Materials Produced at LAAP using 58mm TSE Technology.

Material	Ingredients	Quantity, lbs
Rocket Propellant	AP, Al, HTPB, IPDI	500
PAX-4 High Explosive	CAB, HMX, DEGDN, TEGDN	1000
PAX-2A High Explosive	CAB, HMX, BDNPA/F	1000
M39 LOVA Gun Propellant	CAB, Ethyl Centralite, Ethyl Acetate, NC, RDX	200
M43 LOVA Gun Propellant	CAB, Ethyl Centralite, BDNPA/F, NC, RDX	200
TPE LOVA Gun Propellant	LRG-999, RDX, NC	150

In order to consolidate processing capability, the 58-mm TSE facility installed at LAAP was relocated to the Thiokol Wasatch Plant located in Utah during 1997. All of the extrusion processing equipment previously located at LAAP has been transferred to the Utah plant and is currently being thoroughly refurbished and reinstalled. Inert energetic material processing operations began at the new facility in June of 1998, and live processing of energetic materials are currently being conducted to support contract delivery requirements.

Background

Extrusion processing capability was enhanced at Thiokol Corporation in 1996 with installation of 19mm B&P Process Equipment TSE at Thiokol Wasatch Science and Engineering (S&E) Laboratories. Capitalizing on the design efforts completed by LAAP, the 19mm TSE was selected based on its similar split barrel design, similar processing capabilities, and lower throughput rate. This machine was 25 1/d in length, had segmented screws and multiple temperature control zones. The lower throughput rate of this machine, nominally 5-10 lbs/hr, when compared to the 58mm TSE, nominally 75-250 lbs/hr, allowed for the development and production of smaller quantities of new energetic material formulations. Working in conjunction with B&P technical representatives, Thiokol S & E personnel converted the 19mm TSE from a plastics processing machine to one capable of safely producing highly energetic materials. Safety enhancements and modifications included design of a remotely located control system, elimination of metal to metal contact points, and a complete replacement of the extruder drive motor system to allow operation in an explosion proof manner.

The facility was equipped with two solid feed systems; both manufactured by Brabender Technologies. One of the feed systems was a 20mm twin screw gravimetric loss-in-weight feeder. This system was microprocessor controlled, and used to feed live molding powders to the extruder. The second feed system was a single screw volumetric feeder used to deliver an inert molding powder to the extruder. The inert molding powder utilized the same thermoplastic elastomer (TPE) binder formulation as the live formulation, the same level of solid loading by mass, and the same solid material particle size distribution. The inert material was delivered to the extruder at the same mass flow rate as the live material and was used during start-up of the process to center the screws. The inert material was also used during shutdown to purge the extruder of live material prior to opening the equipment for cleaning and maintenance.

This extrusion system was successfully used to process 280 lbs of live TPE based gun propellant. The material that was produced had high-density values, nominally 99 % of the theoretical maximum density of the formulation, and exceptionally smooth surface finishes. Ballistic reproducibility of the material was also found to be excellent.

However, despite the initial success in extruding energetic materials at this facility, an incident occurred during the processing of additional TPE based gun propellant. In-process material was ignited in the discharge end of the extruder, and the resulting fire propagated along the length of the extruder screws and into the feed chute used to deliver the molding powder to the extruder. Since the feed chute was a solid stainless steel tube, the fire easily continued to propagate to the molding powder remaining in the hopper.

This molding powder rapidly deflagrated, causing significant damage to both the feed system and the rest of the facility. The incident investigation led to several recommendations for improving the system safety of original extruder installation. These recommendations included use of a more elaborate data collection system that displayed trending of key processing variables in real time, installation of an IR thermocouple at the die discharge to independently monitor extrudate temperature, and development of a system that allowed the feeder to be isolated from the extrusion process.

19mm Facility at M-241

As a result of the processing incident involving gun propellant, Thiokol was presented with the opportunity to build a new small-scale extrusion facility at another more remote location. The new location at building M-241 was chosen due to its remote location from the rest of the plant and the overall design of the building and control bunker. The M-241 building was much larger than the previous facility while the control bunker was an entirely separate building designed as an earthen structure capable of withstanding an energetic event. The M-241 building was also tall enough to allow the installation of a mezzanine that would be used to house feed systems. An additional benefit to choosing this facility was the presence of all utilities, vacuum equipment, and climate control equipment including humidity control.

Based on previous experience with the initial 19mm TSE facility, a decision was made to procure an identical, new 19mm machine from B&P, as well as a new solid gravimetric loss in weight feed system from Brabender Technologie. As with the first facility, several safety enhancements had to be added to the extruder to allow processing of energetic materials. These enhancements included the addition of an Allen Bradley based control system complete with real time trending capability, elimination of metal to metal contact points, and a complete replacement of the extruder drive motor system to allow operation in an explosion proof manner. Additional equipment that was installed in the facility includes a second solid gravimetric feed system, two liquid gravimetric feed systems, and a volumetric single screw feed system. Brabender Technologie also supplied these additional feeders.

Unique in the installation of this equipment was the development and testing of a solid feeder isolation mechanism⁶. Tests conducted at Thiokol showed that using such a mechanism to isolate energetic material feed equipment and feed streams from the extrusion processing equipment would greatly increase overall system safety. The system installed in the facility is shown diagrammatically in Figure 1 below.

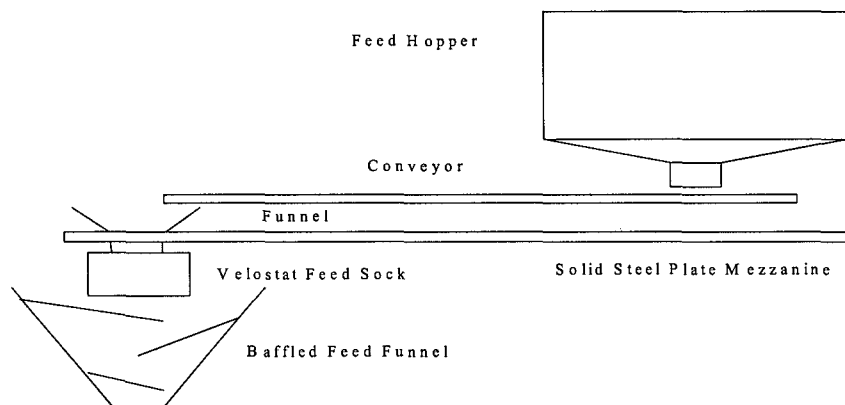

Figure 1: Diagram of Feeder Isolation Mechanism.

The isolation system uses a conveyor located on the mezzanine to deliver raw material from the feeder to a funnel located approximately 2 feet from the feeder discharge on the floor of the mezzanine. Raw materials pass through this funnel into a Velostat sock that discharges into a baffled feed funnel. The baffled funnel has three interior baffles that do not allow the raw material to travel in a straight path downward into the

extruder. Additionally, these baffles were designed to direct any flame from an extruder fire outward into the processing bay, while minimizing the amount of flame that travels upward through the Velostat sock. This feeder isolation system was tested using live material, an old twin screw extruder, and a full scale engineering prototype of the baffled funnel, Velostat sock, mezzanine funnel, and conveyor. In the final test, energetic material within the extruder was initiated using an electric match and the resulting flame from the decomposition of the material did not reach the raw material on the conveyor belt.

Changes were also made to the fire detection system in the M-241 facility. A total of 5 IR sensing detectors were used in the new deluge system to detect the occurrence of an anomalous event. These five sensors were positioned to allow maximum coverage of the extruder and redundant coverage of the feed systems. The completed facility is depicted in the photographs that comprise Figure 2.

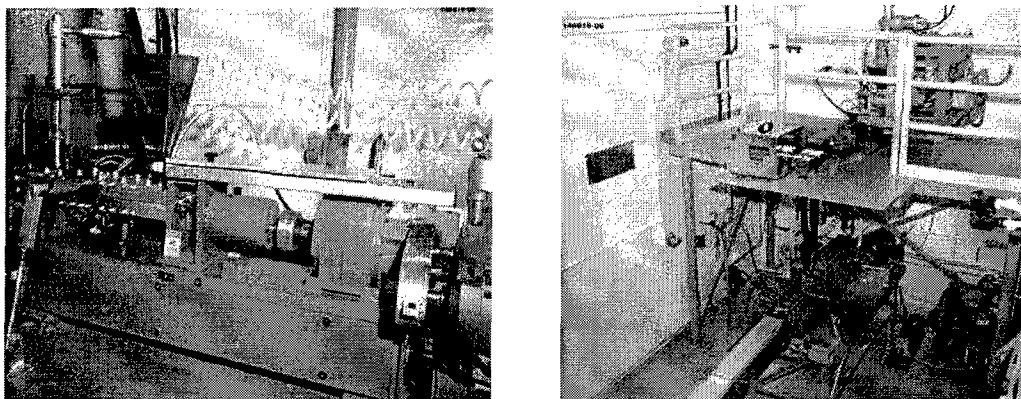

Figure 2: Photographs of M-241 19-mm Twin Screw Extrusion Facility

In addition to installing several safety enhancements in the M-214 facility, Thiokol's participation in the Army's TIME program⁷ allowed the installation of a fiber optic computer network which allows remote monitoring of processing operations at M-241. The system utilizes two computers within the control room to send both real time processing and video data to other locations on the network. Currently, the additional nodes on the network are located at the U.S. Army ARDEC facility in Picatinny, New Jersey, and at the Stevens Institute of Technology in Hoboken, New Jersey.

Processing Results

The M-241 facility became operational in March of 1998. Since that time, approximately 1,500 pounds of energetic material have been extruded in this facility during the completion of 60 extrusion runs. Energetic formulations that have been processed range from TPE gun propellants to solvent-based explosives. The longest extrusion run required 60 hours to complete and produced 240 lbs of TPE gun propellant material. All runs were interrupted on an hourly basis to collect extrudate and to refill feed hoppers.

During the course of an extrusion run, several processing parameters are monitored, recorded, and presented in a trend format. Monitored parameters include screw speed, screw torque, raw material feed rates, die pressure, melt temperature, barrel zone temperatures, IR thermocouple measured temperature, and vacuum level. Data are displayed in a real time format on the computer system used to control the process, while a separate computer is used to generate trend plots of the process variables and to record all processing data. Use of a two-computer system allows for real time temporal comparisons of both instantaneous processing data and trends with past results. This system has been advantageous in the design

and optimization of different extrusion processing configurations. Typical processing data from a run that produced a solvent-based explosive are shown in Figure 3.

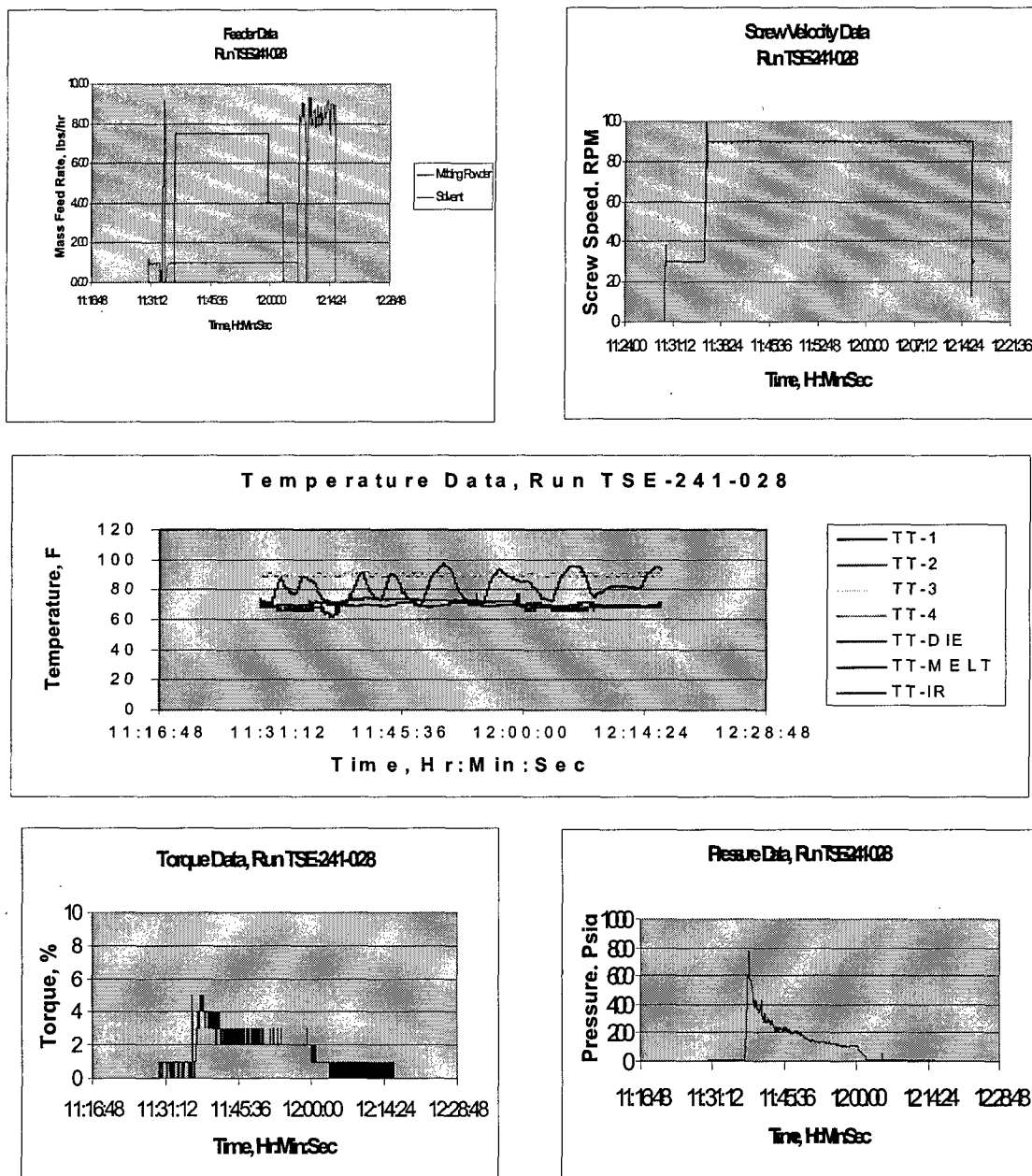

Figure 3: Data from Processing Run TSE-241-028

Extrudate geometries that have been produced include 0.5-inch diameter, 7 perforation strands, solid strands with a width of approximately 0.8 inches and thickness of 0.2 inches, and various cylindrical strands ranging in diameter from 0.1 inches to 0.5 inches. Two different methods have been successfully employed to produce different extrudate geometries. One method involves the use of a die bolted to the exit plane of a jacketed die block attached to the end of the extruder. The second method involves incorporation of the die geometry within the die block. All extrudate dies were designed, manufactured, and tested by Thiokol personnel.

Conclusions

The 19mm TSE facility at Thiokol has been used to produce a large variety of energetic materials. Extrudates produced in this facility include explosives, gun propellants, and pyrotechnics. Based on this processing experience, the following conclusions can be drawn:

- 1.) The 19mm TSE can be configured to safely process energetic materials. The segmented screw design and multiple feed ports on this machine allow for a wide range of processing options. Vacuum application may be used to achieve high-density products.
- 2.) Employing a mechanism to separate the feed systems from the extruder can significantly increase safety of processing operations. In this facility, feeder isolation is accomplished using a conveyor belt, a Velostat feed sock, and a baffled feed funnel.
- 3.) Using a computer control system that displays processing data in both a real time and a trend format can significantly increase processing capability and safety.

References

- 1.) Dillehay, D.R. "Longhorn Twin Screw Extruder Installation", Proceedings of Second Annual Continuous Mixer and Extruder Users' Group Meeting, December 1988.
- 2.) Dittman, T.G. "Twin Screw Extruder Overview", Proceedings of Third Annual Continuous Mixer and Extruder Users' Group Meeting, December 1989.
- 3.) Dillehay, D.R. "Processing on the ZSK-58E Twin Screw Extruder", Proceedings of Third Annual Continuous Mixer and Extruder Users' Group Meeting, December 1989.
- 4.) Dillehay, D.R., "Flexible Manufacturing Plant Applications for LOVA Gun Propellant", JANNAF Propulsion Meeting, 1993
- 5.) Dillehay, D.R., "Continuous Processing of Energetics on Twin Screw Extruders", Proceedings of the Life Cycle of Energetics, 1994.
- 6.) Rose, M.T., Haaland, A.C., Bradley, S.J., and Harper, M.R., "A Method of Isolating Energetic Material Feed Systems from Extrusion Processes", Manuscript in Preparation.
- 7.) U.S. Army Contract with Thiokol Corporation. Contract Number DAAA-21-94-D-003, Task 12.

Processing of Energetic Materials at Thiokol's 19mm Twin Screw Extrusion Facility

NDIA Munitions Technology Symposium

April 6, 1999

Prepared by:

Andrew Haaland, Quinn Barker, Michael Rose

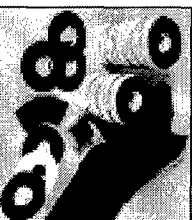
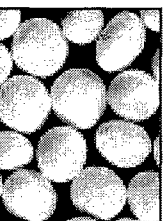
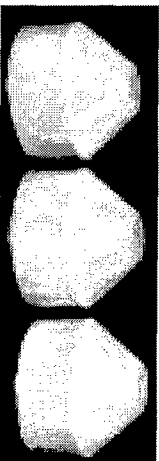
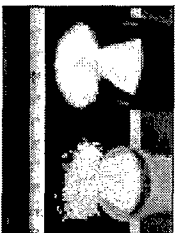

50 YEARS OF SOLID PROPULSION



**Thiokol
Propulsion**

From Cordant Technologies

Outline

- **Overview and background**
 - Previous extrusion processing efforts at Thiokol
 - Initial 19mm TSE Facility
- **Installation of New Facility at M-241**
 - Feed System Isolation
 - Control System
 - Additional Process Monitoring
- **Processing Results**
 - Process Parameters
 - Extrudate Quality
- **Summary**

Overview & Background

Previous Extrusion Processing Efforts at Thiokol

- Initial twin screw extruder (TSE) installed at Longhorn Army Ammunition Plant (LAAP)
 - 58 mm diameter Werner & Pfleiderer extruder
 - Several liquid and solid feed systems
 - Development of post processing equipment and techniques
- **Extrusion facility was successfully used to process propellants, explosives, and pyrotechnics.**

Material	Ingredients	Quantity, lbs
Rocket Propellant	AP, Al, HTPB, IPDI	500
PAX-4 High Explosive	CAB, HMX, DEGDN, TEGDN	1000
PAX-2A High Explosive	CAB, HMX, BDNPA/F	1000
M39 LOVA Gun Propellant	CAB, Ethyl Centralite, Ethyl Acetate, NC, RDX	200
M43 LOVA Gun Propellant	CAB, Ethyl Centralite, BDNPA/F, NC, RDX	200
TPE LOVA Gun Propellant	LRG-999, RDX, NC	150

- **Facility moved from LAAP to Utah in 1997**

Overview & Background

Thiokol 58mm TSE located in Utah

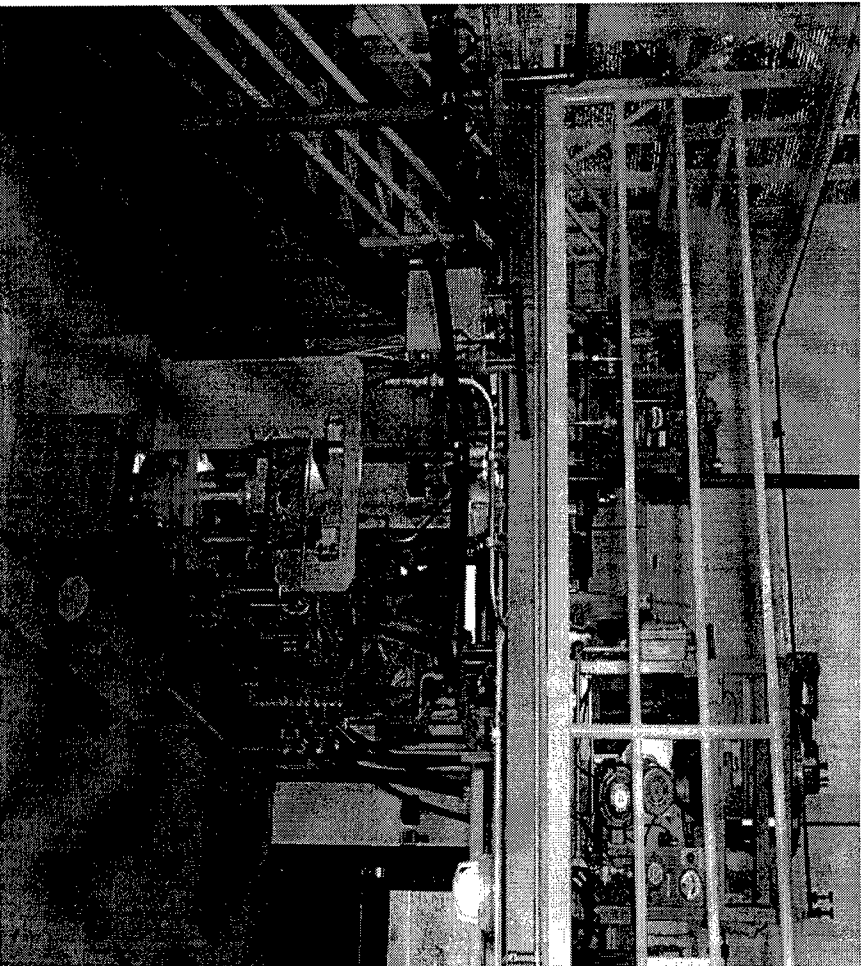

- Facility is currently operational processing live materials

Overview and Background

Initial 19mm TSE Facility

- Success at LAAP cultivated a desire to create small scale TSE facility in Utah
- Selected B&P 19mm TSE
 - 25 l/d, segmented screw, split barrel design
 - 5-10 pounds/hour through put rate
 - Converted from plastics machine to energetic machine
 - Explosion proof electrical
 - Elimination of metal to metal contact points
 - Remotely located control system
- Selected Brabender twin screw gravimetric feeder
- Successfully processed 280 pounds of TPE gun propellant
- Thiokol designed product collection equipment

Overview & Background

Initial 19mm TSE Facility Process Flow

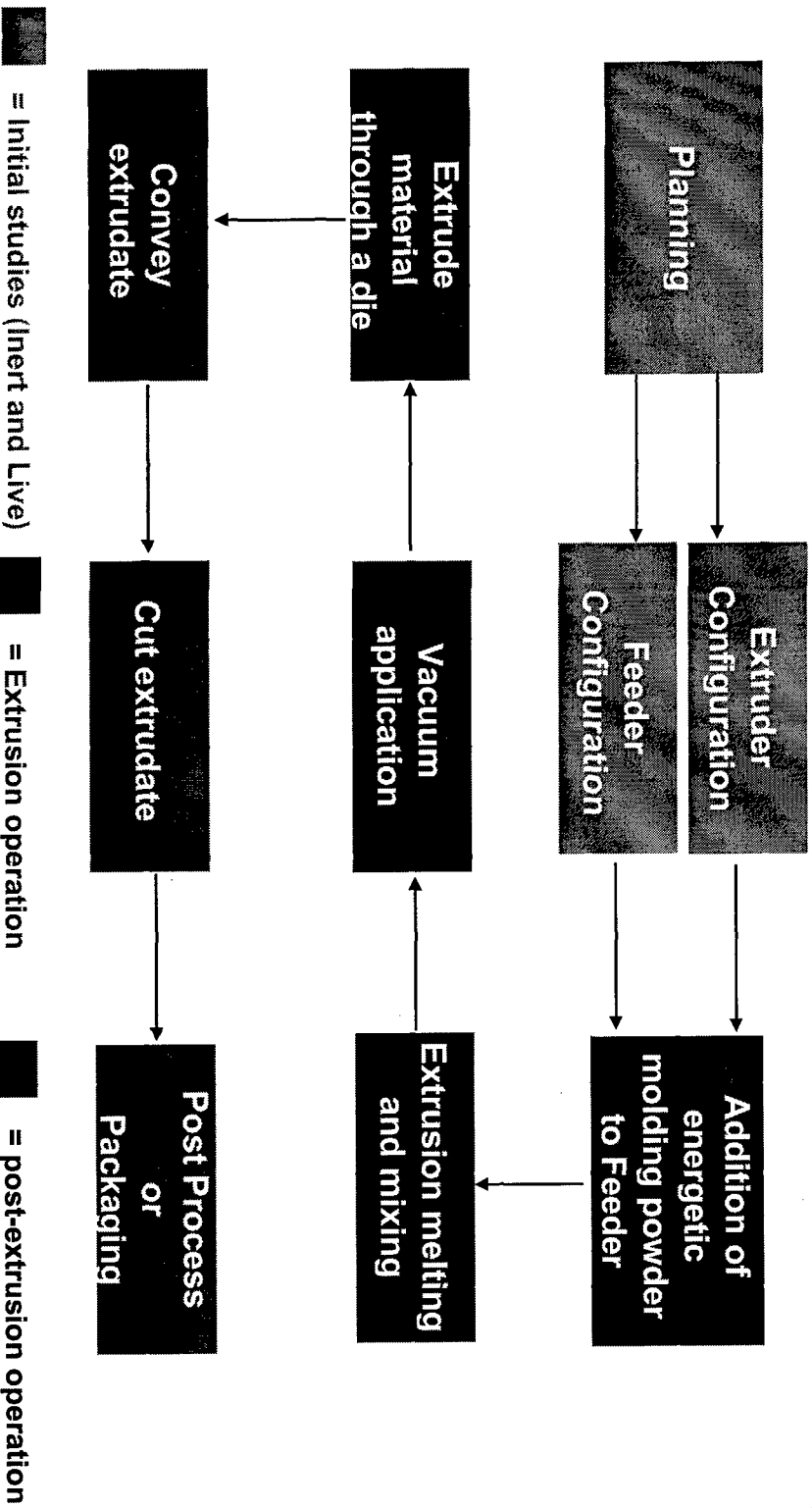

Overview & Background

Initial 19mm TSE Facility

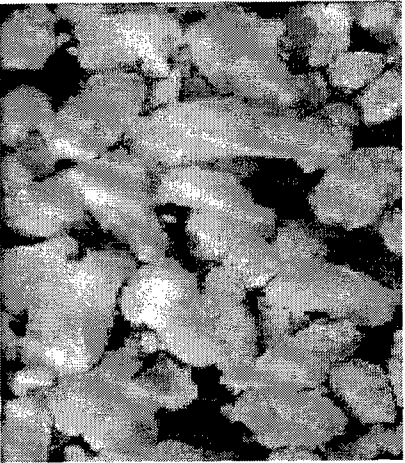

**Molding
Powder
For Twin
Screw
Extrusion
Feedstock**

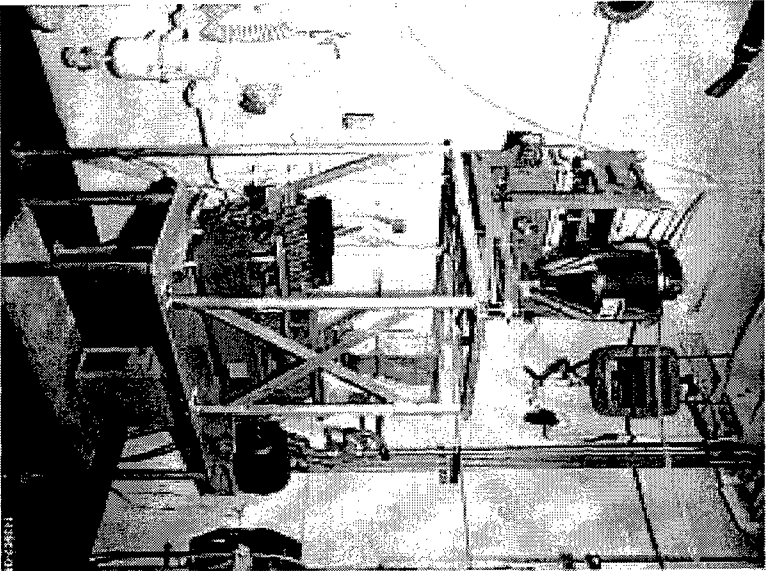

M-56 19mm TSE

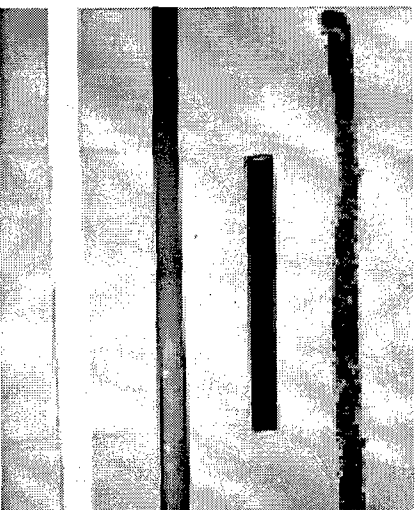

**Solid Strand
Gun Propellant
Extrudate**

Overview & Background

19mm TSE Processing Incident

- **Incident Description**
 - Occurred while processing TPE Gun Propellant
 - Ignition result of thermal decomposition due to overwork in discharge end of extruder
 - Fire propagated to forward end of extruder, spread up feed chute, and ignited remaining molding powder in feed hopper
- **Damage Assessment**
 - Feeder and hopper completely destroyed
 - Sustained minor damage to extruder
 - Significant damage to processing building
- **Provided opportunity to learn and build a better facility**

Overview & Background

19mm TSE Incident

- **Investigation results**
 - Improve data collection and control capability
 - Install better instrumentation on extruder
 - Isolate feeder from extrusion process
 - Isolate process from other areas of the plant
- **Incident was viewed as an opportunity**
 - Initial extrusion efforts were viewed as successful
 - Lessons learned could be applied to construction of a newer, more capable small scale facility
 - Investigation results could be applied to a wide range of energetic materials processes

Extrusion Facility Installation

Facility Design Activities

- **Facility Design divided into four major areas**
 - Search for new location
 - More remote location
 - Dedicated, bunker style control room
- **Feed system isolation studies**
 - Extruder fire would not propagate to feeder
 - System would allow fire detection and deluge operation
- **New control system design**
 - Computer based
 - Real time trending capability
 - Improved process instrumentation
- **All activities were undertaken in a parallel manner**

Extrusion Facility Installation

Facility Design Activities - New Location

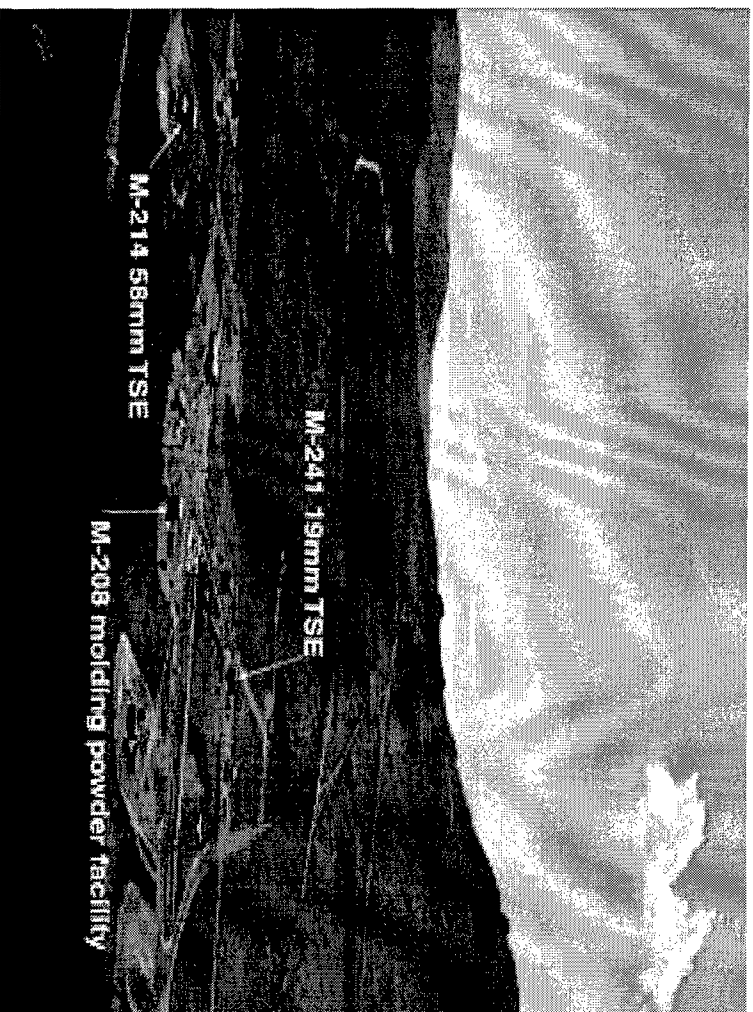

- M-241 selected due to remote location, dedicated control bunker

Extrusion Facility Installation

Feed System Isolation Studies

- System design employed a conveyor, solid steel plate mezzanine, Velostat® feed sock, and baffled funnel. Thiokol has a patent pending on this approach.

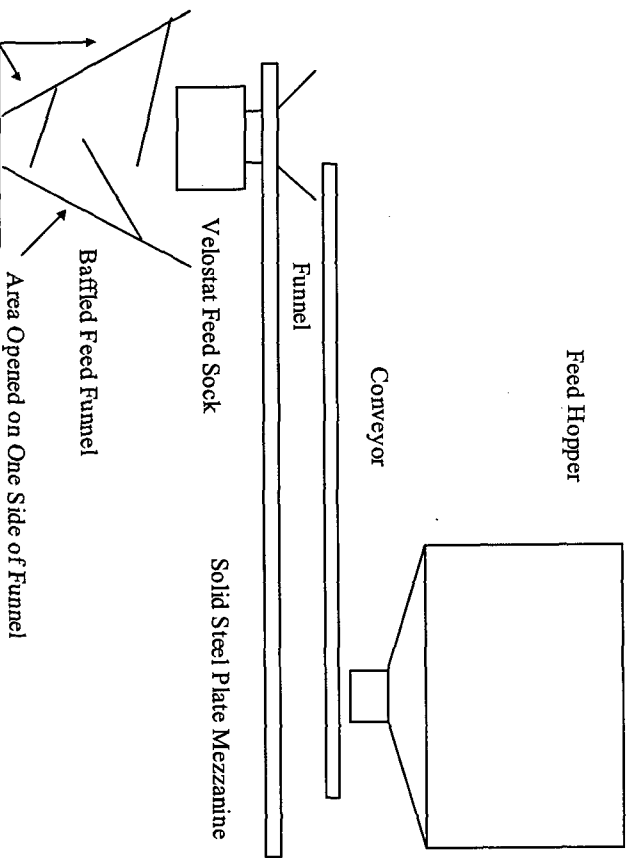

Extrusion Facility Installation

Feed System Isolation Studies

- Complete system was tested using live materials

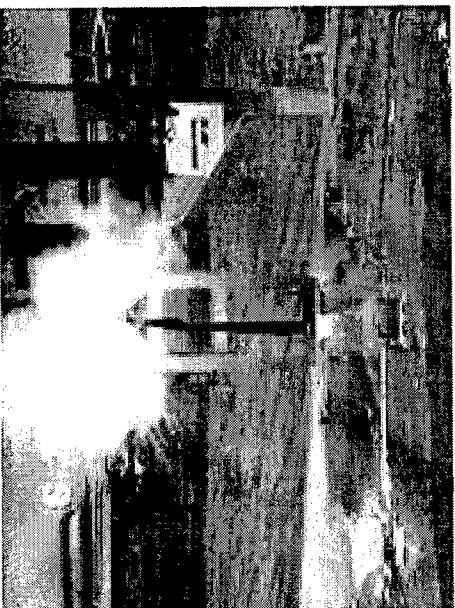

- Fire did not propagate to feed hopper

Extrusion Facility Installation

New Control System and Instrumentation

- **Computer based control and data acquisition**
 - Allen Bradley hardware and software utilizing data highway
 - RSTrend for data acquisition and display of processing data trends
 - Temperatures and pressure
 - Extruder torque and screw speed
 - RSView for process control
 - Operation of all process equipment
 - Instantaneous display of set points and actual performance
- **Army TIME program installed real time network for data transfer**
- **Instrumentation was also improved**
 - Added IR thermocouple to independently measure extrudate temperatures
 - Direct coupled torque and rpm instrumentation to drive shaft

PROPULSION GROUP

THIOKOL

Extrusion Facility Installation

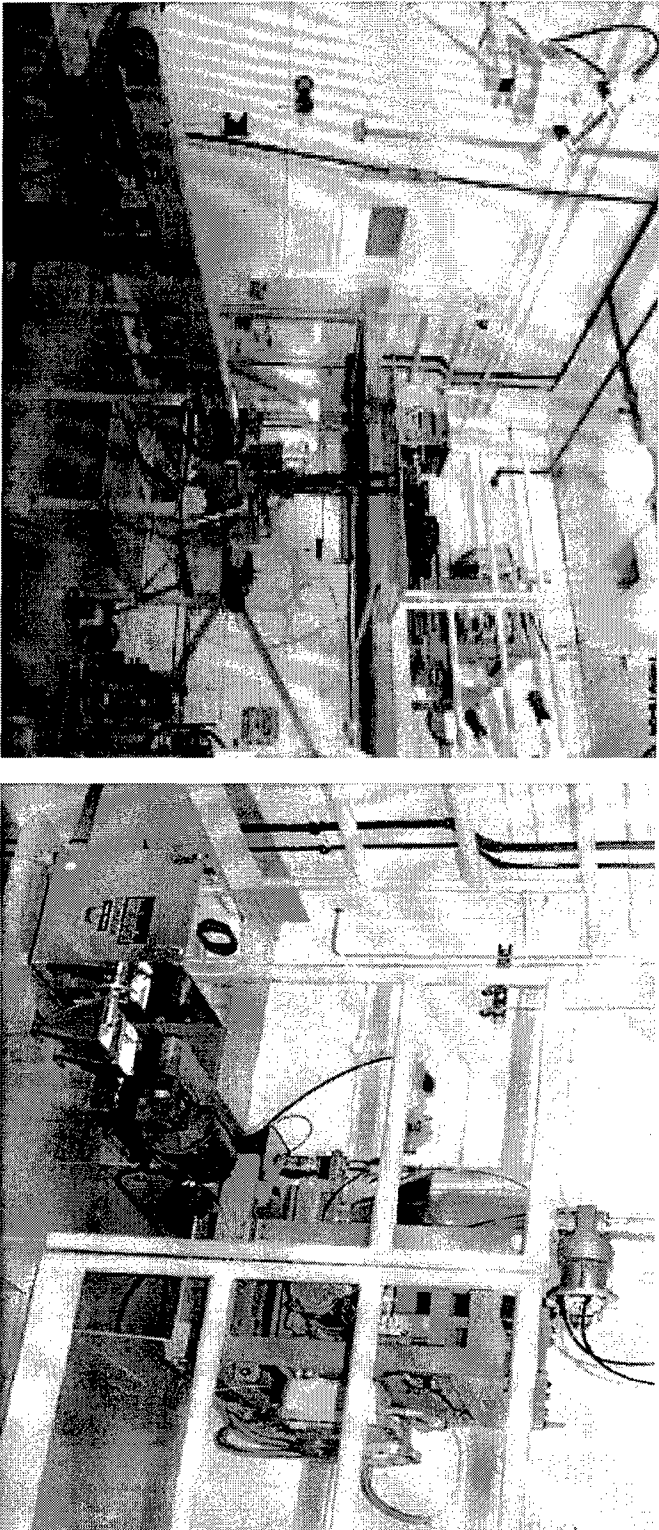

M-241 Facility was completed and operational in March, 1998

M-241 Extrusion Facility Processing

Process Parameter Data

- Facility has been used to complete over 60 runs of energetic material
- Longest run time is 64 hours
- Approximately 1500 lbs of material total has been processed
- Processing data is analyzed and stored

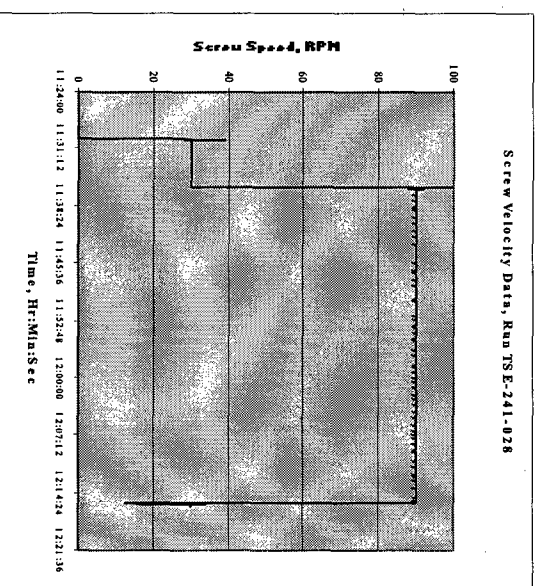
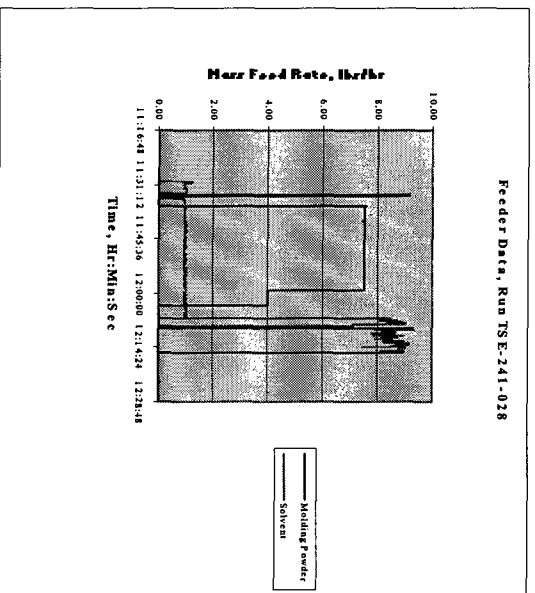

M-241 Extrusion Facility Processing

Extrudate Quality

- Most commonly used measures of extrudate quality are density and surface finish
- Surface finish is a qualitative measurement, however poor surface finish can indicate low density
- High density extrudate has been achieved with vacuum application during long run times

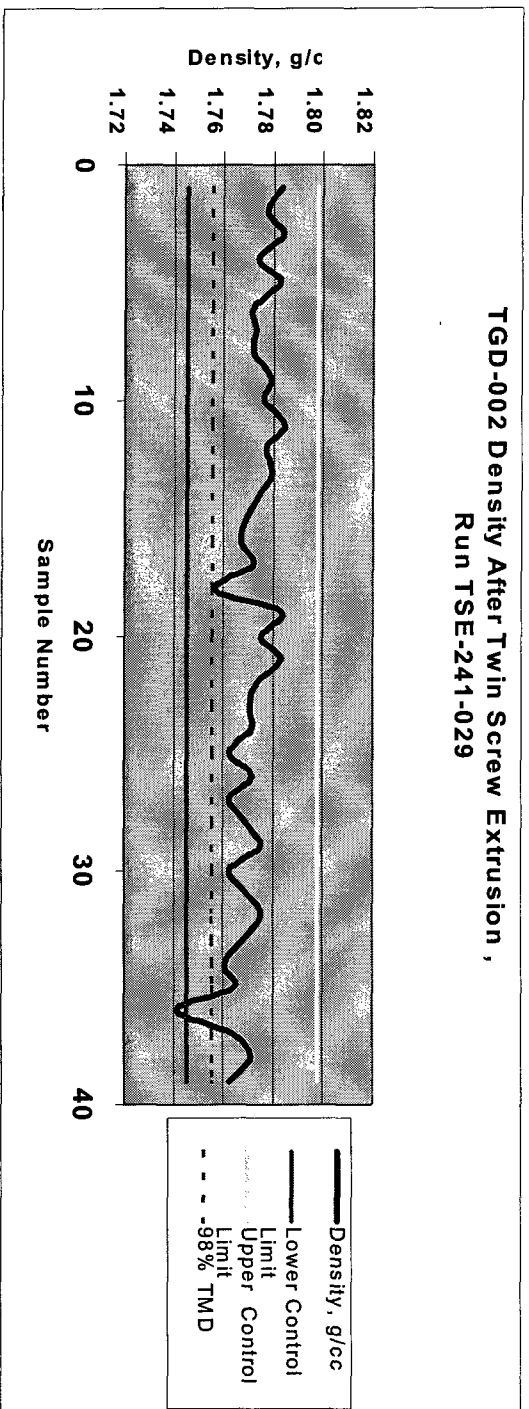

Summary

- M-241 19mm TSE facility has successfully been used to process energetic materials
 - Approximately 1500 pounds total
 - Longest run time was 64 hours
- Facility design was improved through past experience
 - LAAP 58mm TSE
 - M-56 19mm TSE
- Facility capable of producing a wide range of energetic materials
 - Gun propellants
 - Explosives
 - Pyrotechnics



HIGHLY INTEGRATED FIRING MODULE

Mr. Tom Nickolin
Manager Advanced Technology
KDI Precision Products, Inc.

**43rd Annual
Fuze Conference**
"Fuzing Challenges:
Opportunities to Excel"

Munitions Technology
Symposium VI
hosted by "Munitions Manufacturing
and Technology Section"

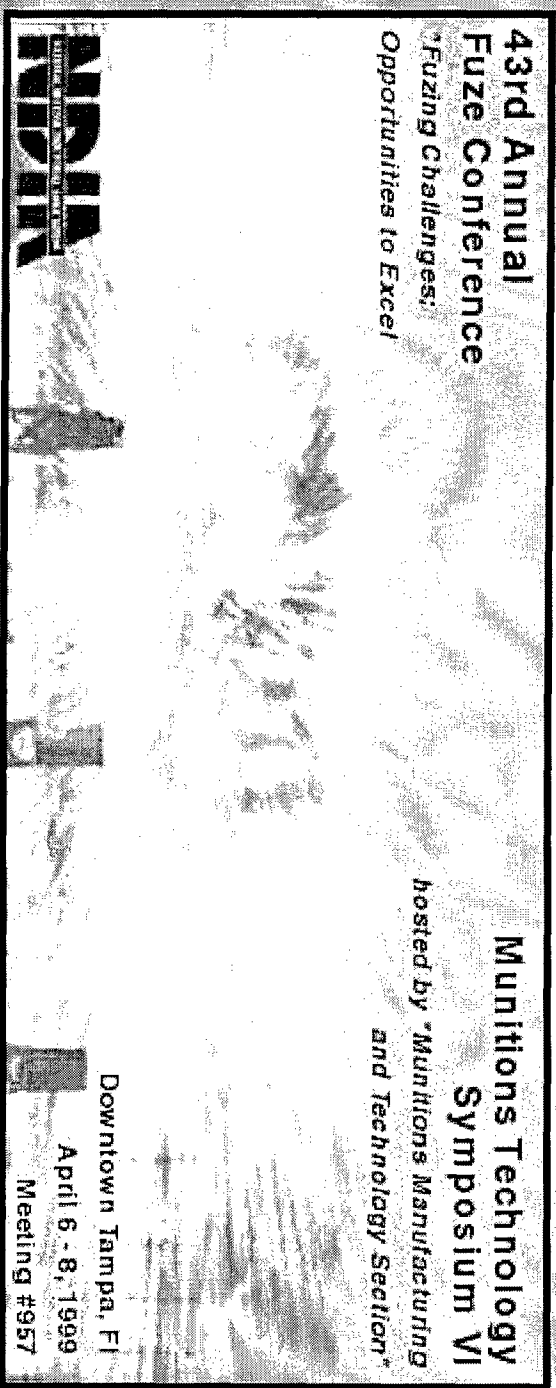

Downtown Tampa, FL
April 6 - 8, 1999
Meeting #957

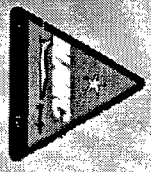

Mr. Jim Denny
Senior Engineer
China Lake



REYNOLDS SYSTEMS INC.

Mr. Tom Reynolds
President
Reynolds Systems



Mr. John Cole
President
Silicon Designs



OUTLINE

- Participants
- Ultimate Objective
- Critical Components
- Solid-State Switch
- Test Data
- Summary





PARTICIPANTS

FOUR PARTY COOPERATIVE RESEARCH AND DEVELOPMENT AGREEMENT (CRADA)



➤ **Participants**

- ✦ **Mr. Jim Denny, China Lake**
- ✦ **Mr. John Cole, Silicon Designs**
- ✦ **Mr. Tom Reynolds, Reynolds Systems**
- ✦ **Mr. Tom Nickolin, KDI Precision Products**





ULTIMATE OBJECTIVE



➤ To Develop a Highly

Integrated Firing Module

- ✧ Small
- ✧ Reliable
- ✧ Low Cost
- ✧ Modular





CRITICAL COMPONENTS



- **EFI / LEEFI**
- **Capacitor**
- **Insensitive Explosive Material**
- **High Voltage Switch**



REYNOLDS SYSTEMS INC.





EFI / LEEFI

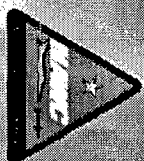

➤ Traditional EFI

- ◆ Kapton Base
- ◆ Etched Copper Bridge
- ◆ 2-3 kv Operating Voltage

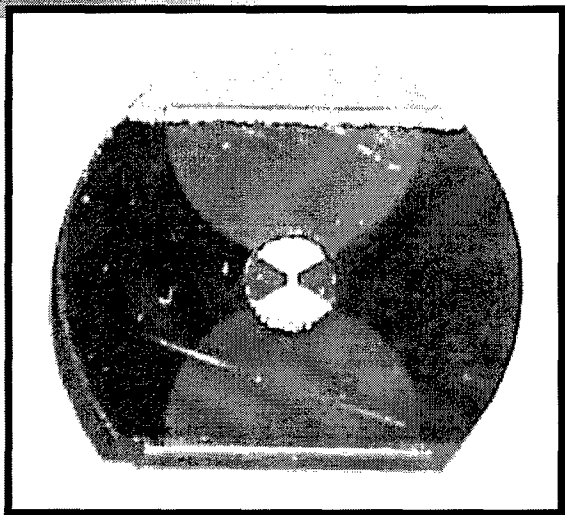
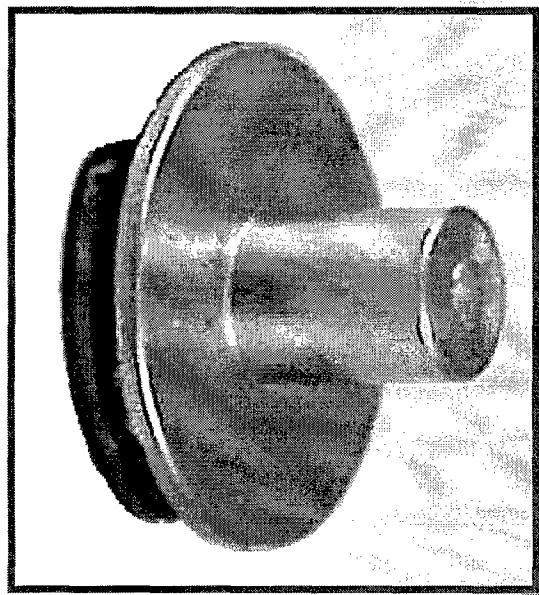



EEFI / LEEFI



LEEFI

- ◆ Ceramic Base
- ◆ Vapor Deposited Bridge
- ◆ Hermetic Seal
- ◆ Lower Operating Voltages
- ◆ Lower Value Capacitor

← .250 →

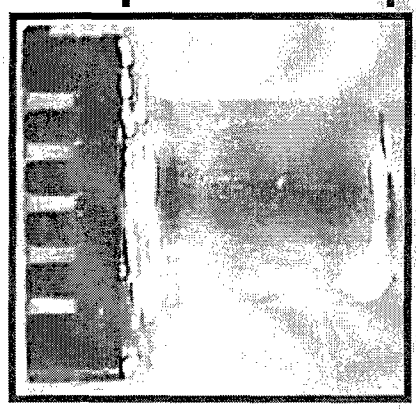

→ | 0.208 | ←

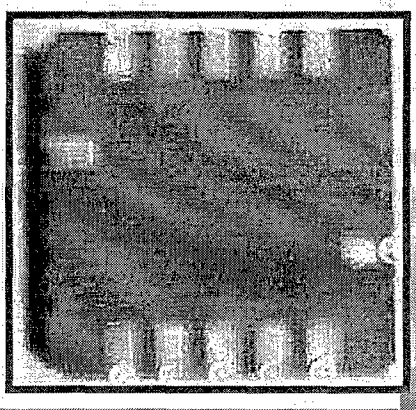

LCC - 20





CAPACITORS

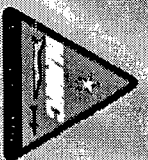

➤ Performance

- ❖ Capacitance
- ❖ Operating Voltage
- ❖ Inductance / ESR
- ❖ Number Firings

Engineering Trade-Off's

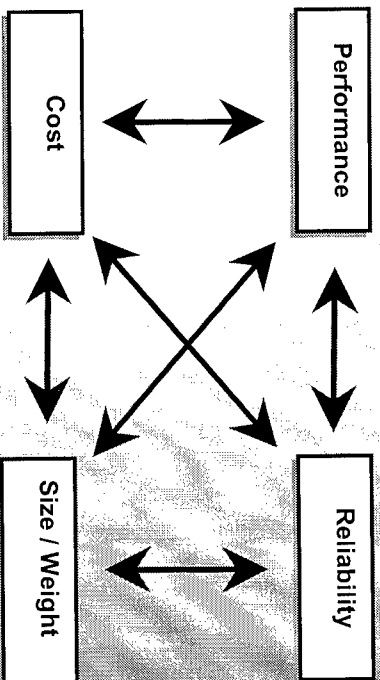

➤ Major Influences

- ❖ Reduced Energy Requirements
- ❖ Technology Advancements



EXAMPLE CAPACITORS

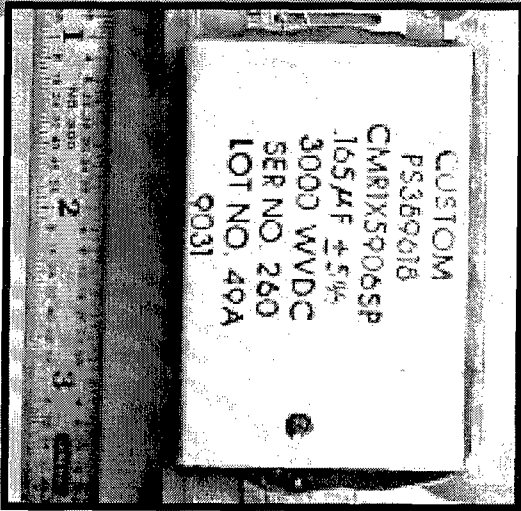

.165 µF 3kv - Patriot ESAD

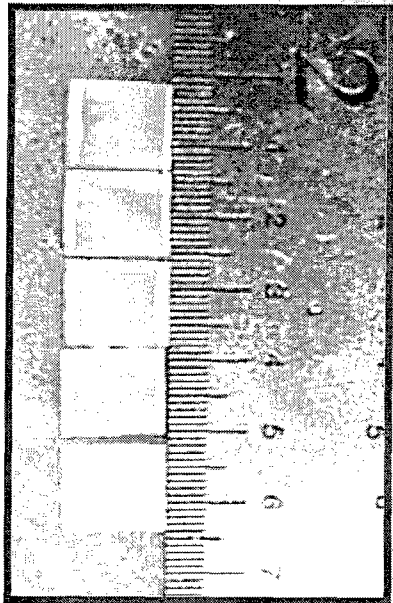

.1 µF 1.5 kv - In Development

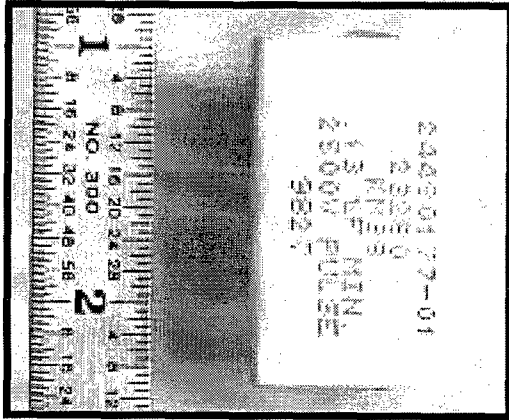

.13 µF 2.5 kv - AIM-9X

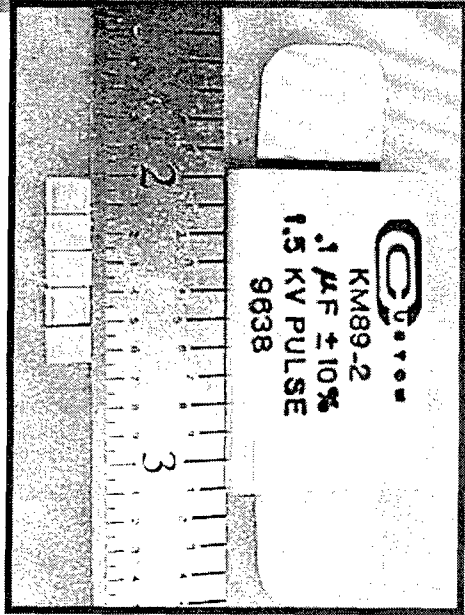

.1 µF 1.5 kv

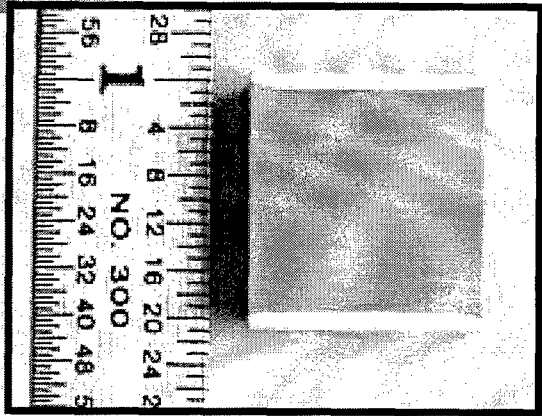

.1 µF 3.0 kv - Swiss Dragon





INSENSITIVE EXPLOSIVE MATERIAL



➤ HNS- IV

- ✧ **Most Popular**
- ✧ **Accepted By MIL-STD-1316D**
- ✧ **Not Certified**
- ✧ **High Cost**





INSENSITIVE

EXPLOSIVE MATERIAL

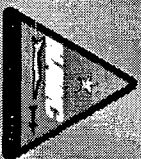

➤ **Alternative Energetic
Material**

- ✧ **Developed By China Lake / RSI**
- ✧ **Nearly Qualified**
- ✧ **Material of Choice for the
Highly Integrated Firing Unit**
- ✧ **Separate NDIA Paper**



REYNOLDS SYSTEMS INC.





HIGH VOLTAGE SWITCH

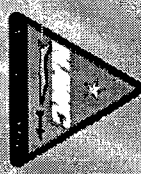

➤ Spark Gap

✧ Gas Filled

✧ Vacuum

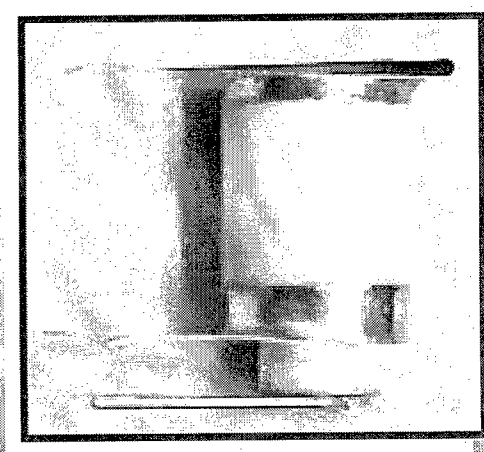

➤ Explosive Kapton Switch





HIGH VOLTAGE SWITCH

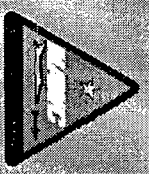

➤ Vacuum Relay

➤ Hybrid

➤ Solid-State Devices

✧ MOSFET

✧ NMCT

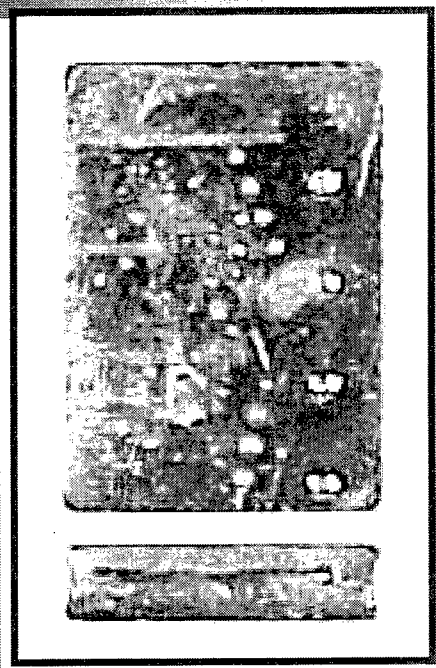
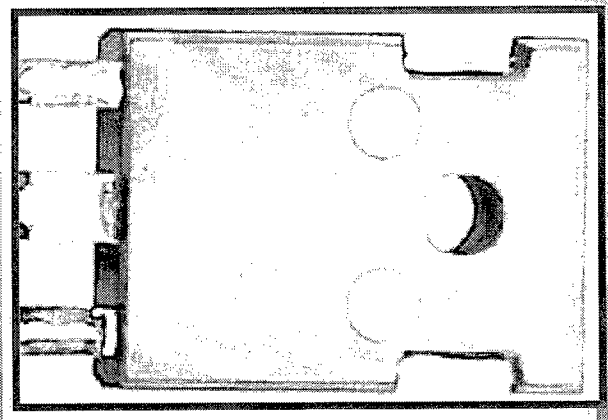



NMCT



➤ 'N' Channel MOS Controlled Thyristor

- ✧ Originally Developed By Harris Semiconductor
- ✧ Product Sold To Silicon Power Corp.
- ✧ Excellent Test Results
- ✧ Separate Presentation By
Mr. Kwong Chu - Sandia





MOSFET

- Commercially Available
- Lower Cost

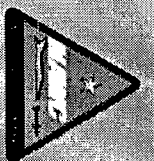



MOSFET

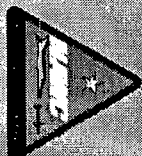

➤ **Application Is Outside Bounds
Defined by Data Sheet**

- ✧ **Voltage Rating, Sufficient**
- ✧ **Pulse Current, Too Low**
- ✧ **On Resistance, Too High**
- ✧ **Switching Speed, Too Slow**



MOSFET PARASITIC ELEMENTS

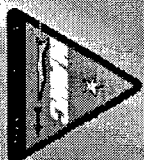

➤ C_{iss} Capacitance - Gate to Source

- ✧ Large for Power MOSFETS (5,000 - 10,000 PF)
- ✧ Reduces Turn On Rate
- ✧ Requires Low Impedance Drive Circuit

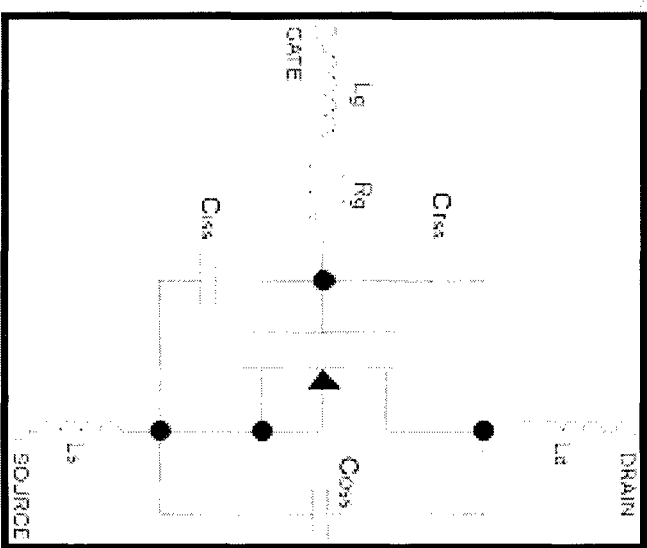

10 MOSFET PARASITIC ELEMENTS

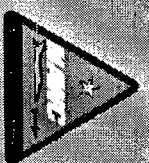

➤ C_{rss} Capacitance - Drain to Gate

- ✧ Couples dv/dt at Drain, to the Gate
- ✧ Degenerative to Turn On
- ✧ Potential to Damage Gate

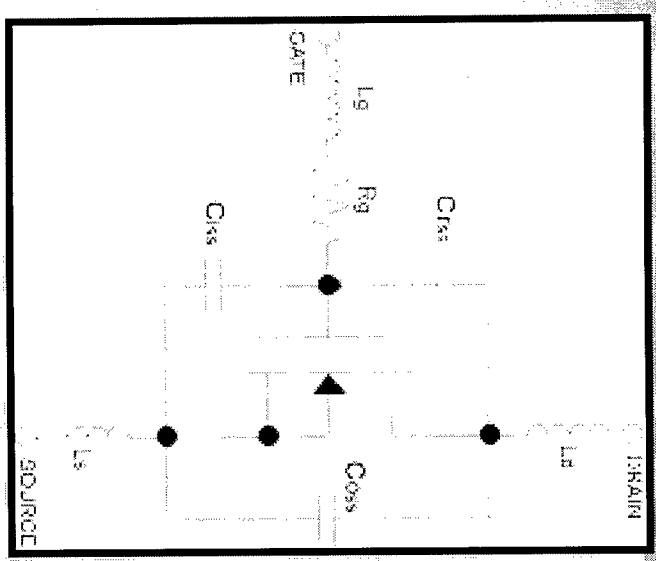

MOSFET PARASITIC ELEMENTS



- L_{ss} Source Inductance
 - ✧ Degenerative to Turn On
 - ✧ Adds to Overall Loop Inductance
 - ✧ Internal to Package
 - ✧ Potential to Damage Gate

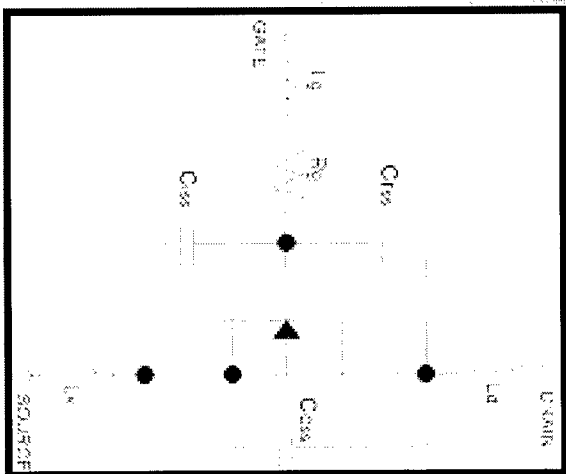

$\frac{di}{dt}$	=	1,000 Amps	=	10,000 Amps
		$\frac{100 \times 10^{-9} \text{ Sec}}$		$\frac{1 \text{ u Sec}}$
L	=	2 nH		
$E = L \cdot \frac{di}{dt}$	=	$(2 \times 10^{-9}) \frac{(10,000)}{10^{-6}}$	=	20 Volts





AVALANCHE THRESHOLD

Avalanche Threshold

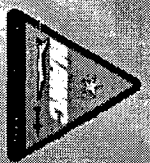
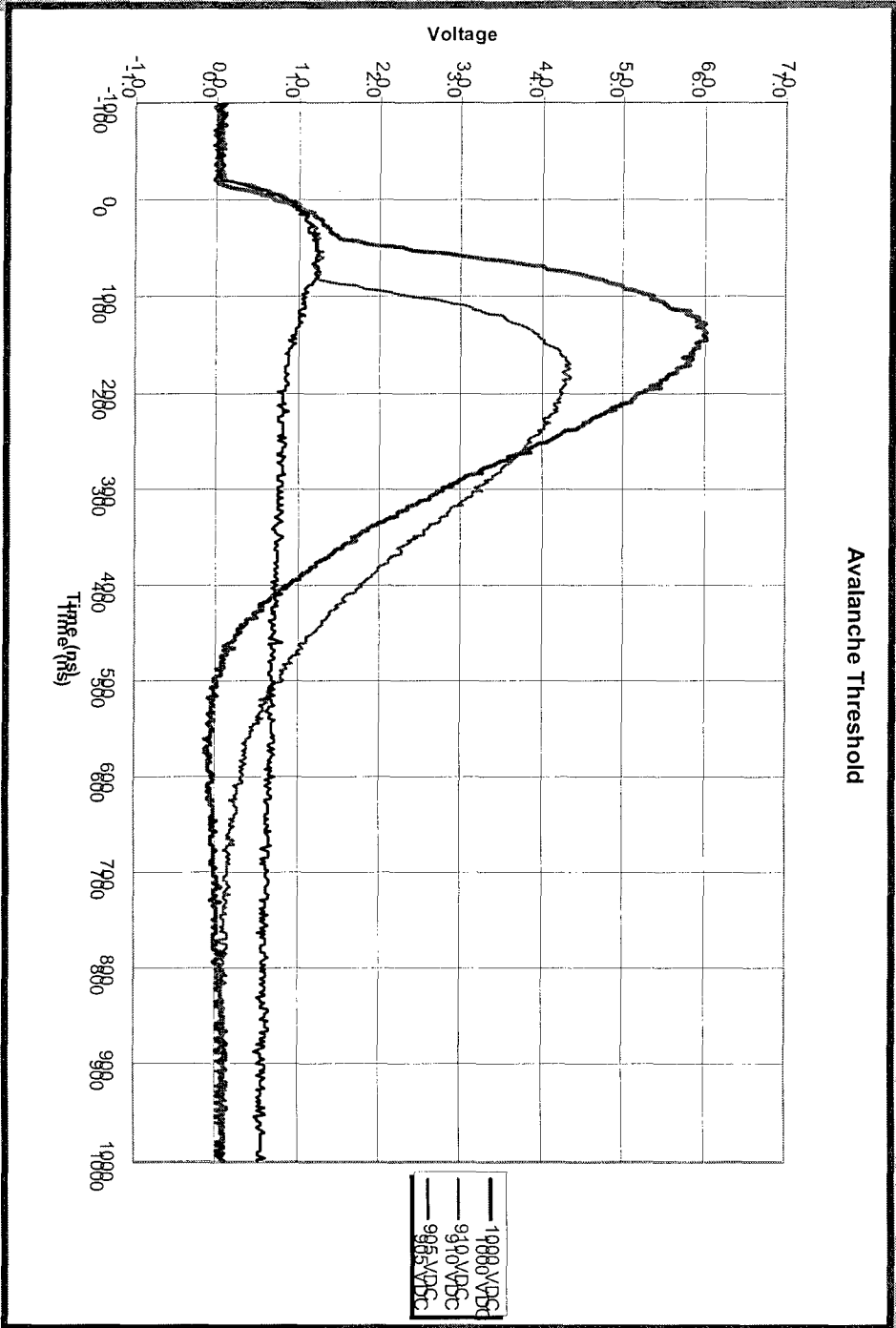



TEST DATA



FET Test 1

V = 1,000 Volts
CVR = 0.5 / .005
IXTH14N100

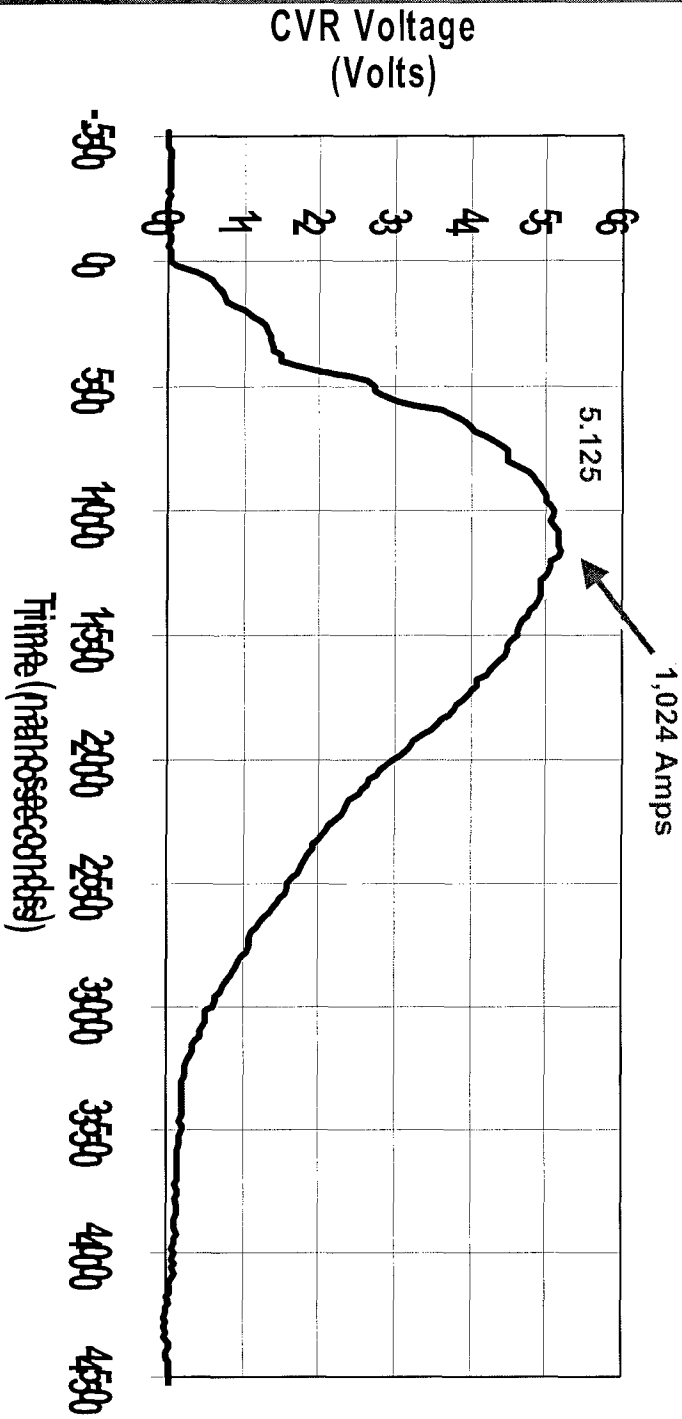

— Test 1





TEST DATA

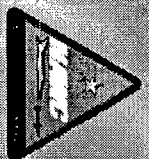

FET Test 300

V = 1,000 Volts
CVR = 0.5 / .005
IXTH14N100

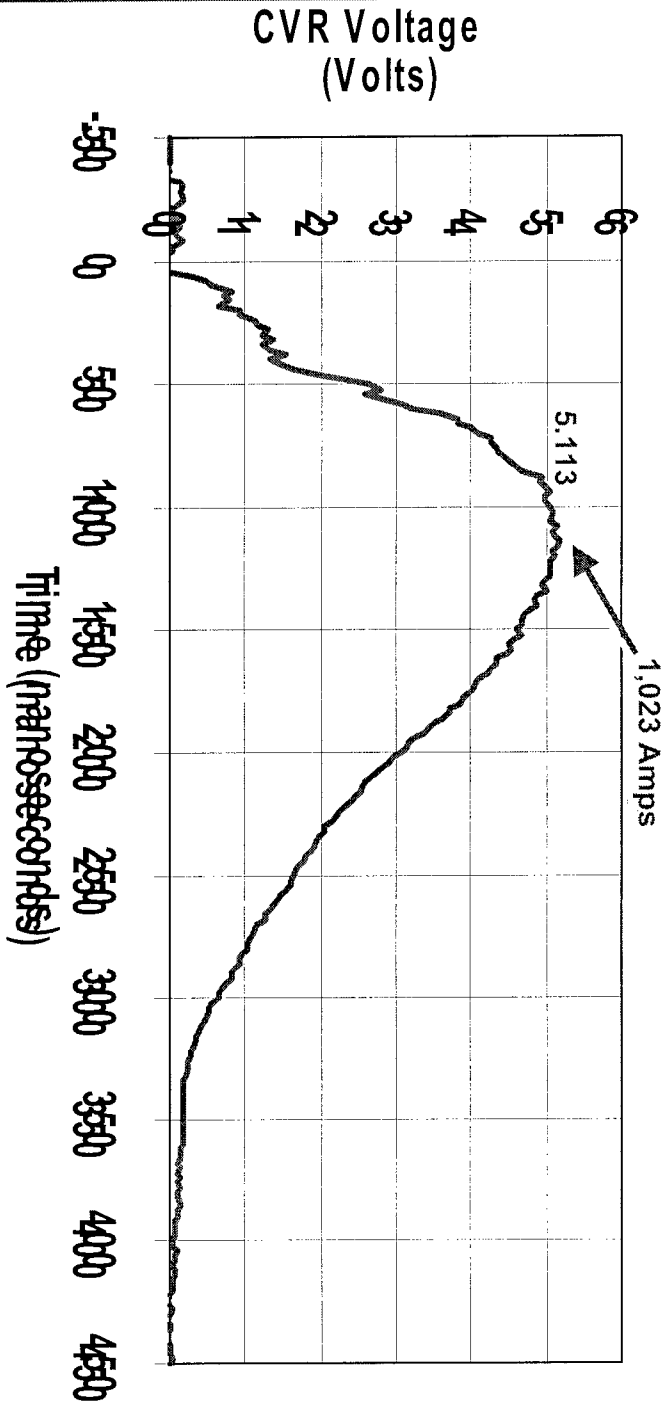

— FET Test 300





TEST DATA

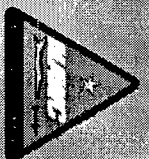

FET Test 1 and 300

V = 1,000 Volts
CVR = 0.5 / .005
IXTH14N100

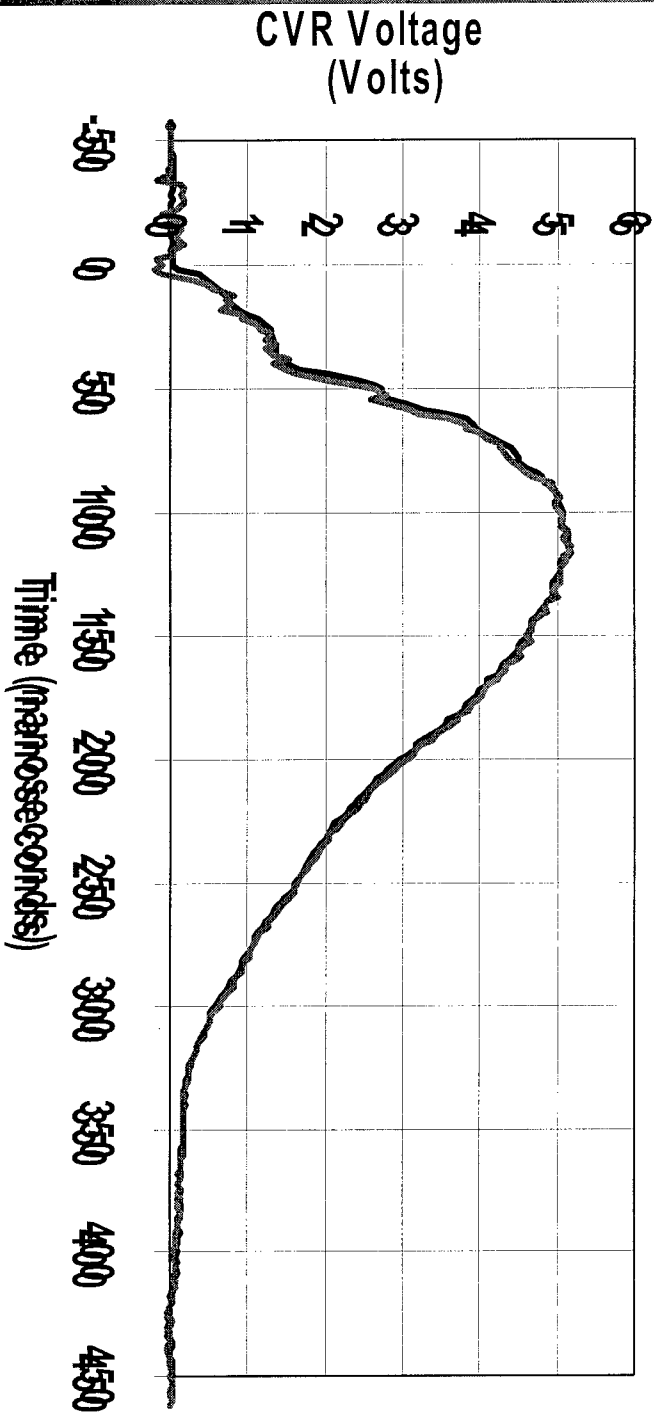

— Test 1
— Test 300



100 HIGH TEMP (160°F) FIRING

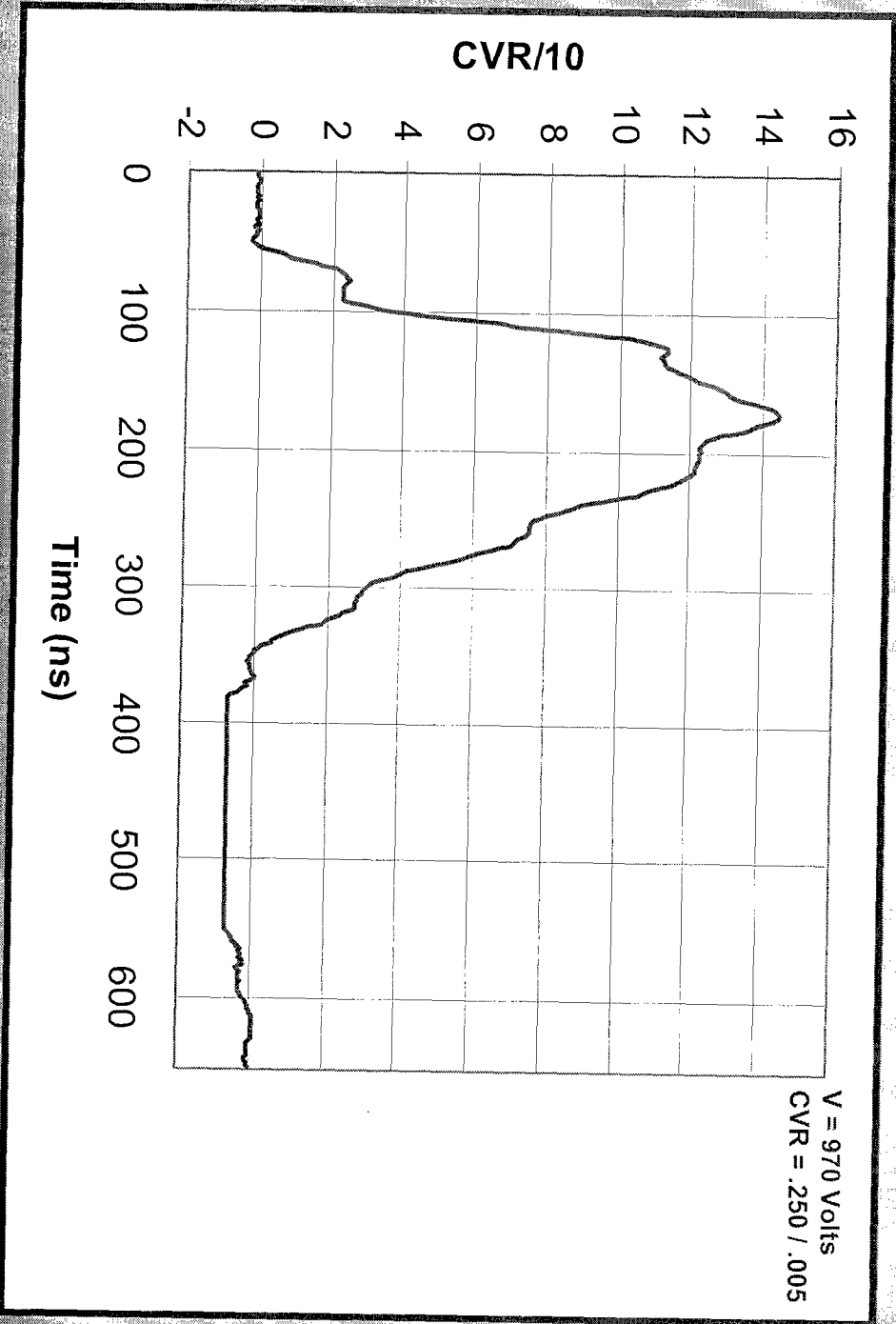



HIGH TEMP VS. LOW TEMP

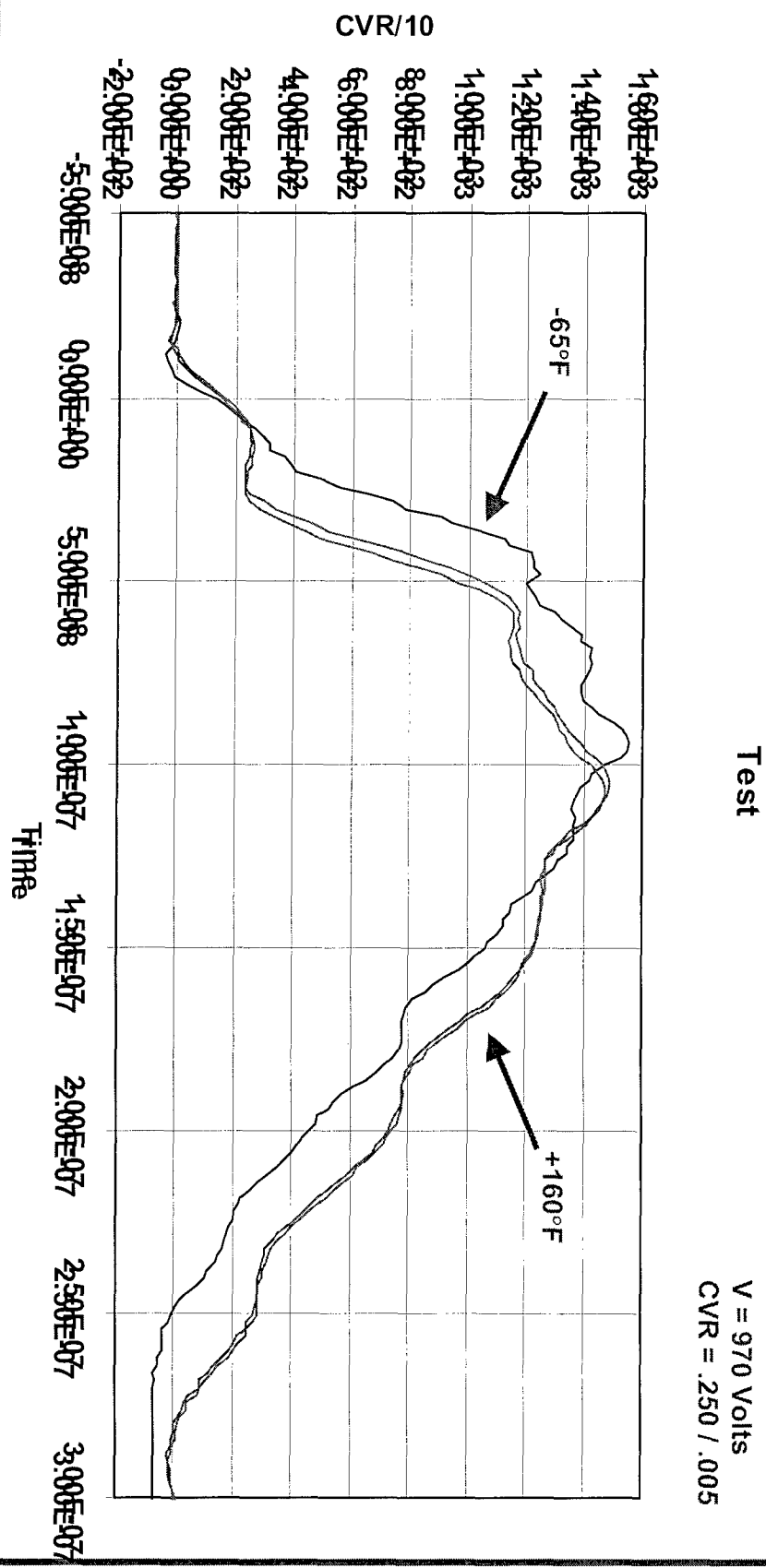
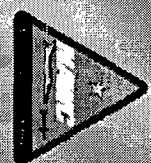



HIGH TEMP VS. BRIDGE

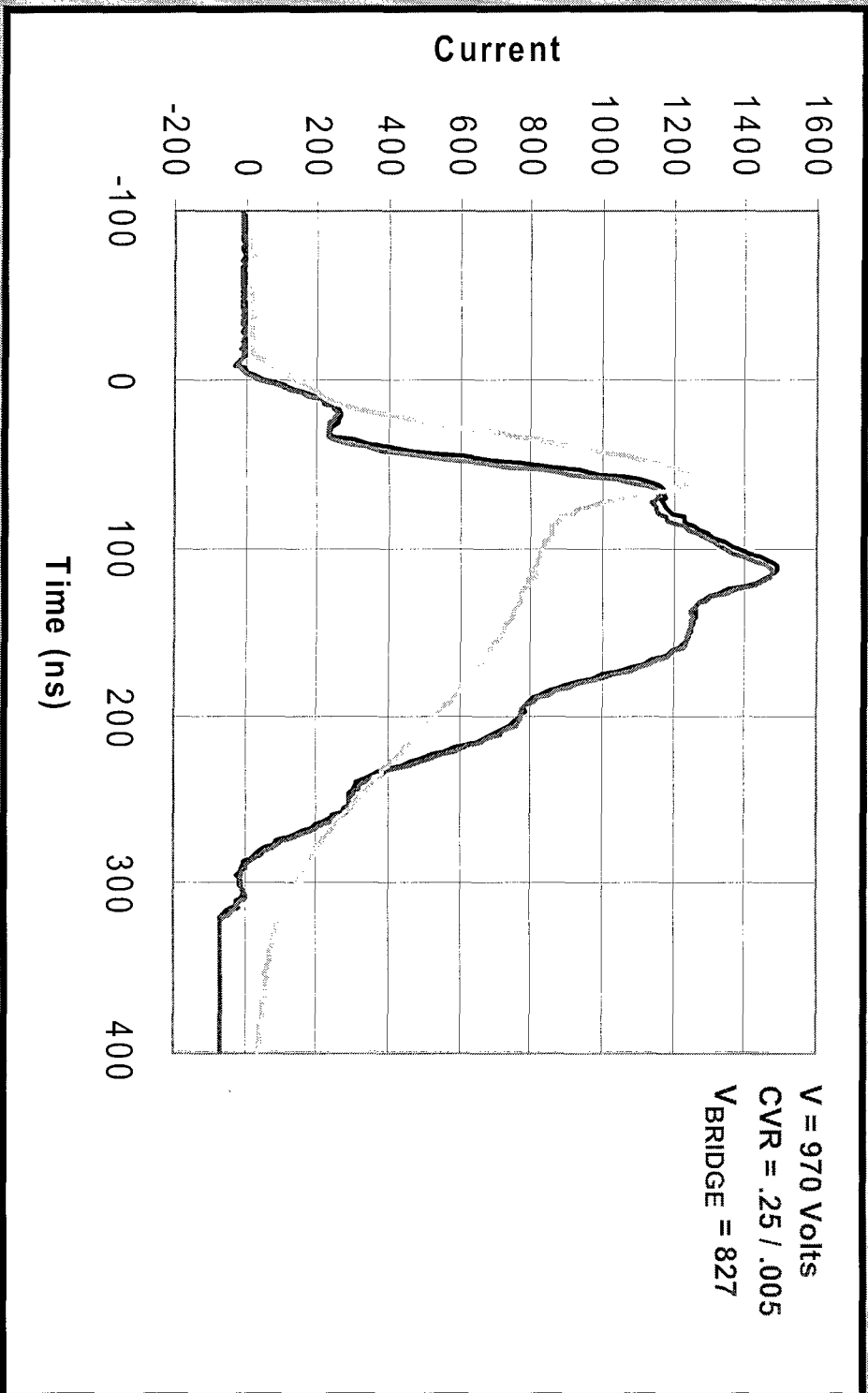



CAPACITOR VOLTAGE

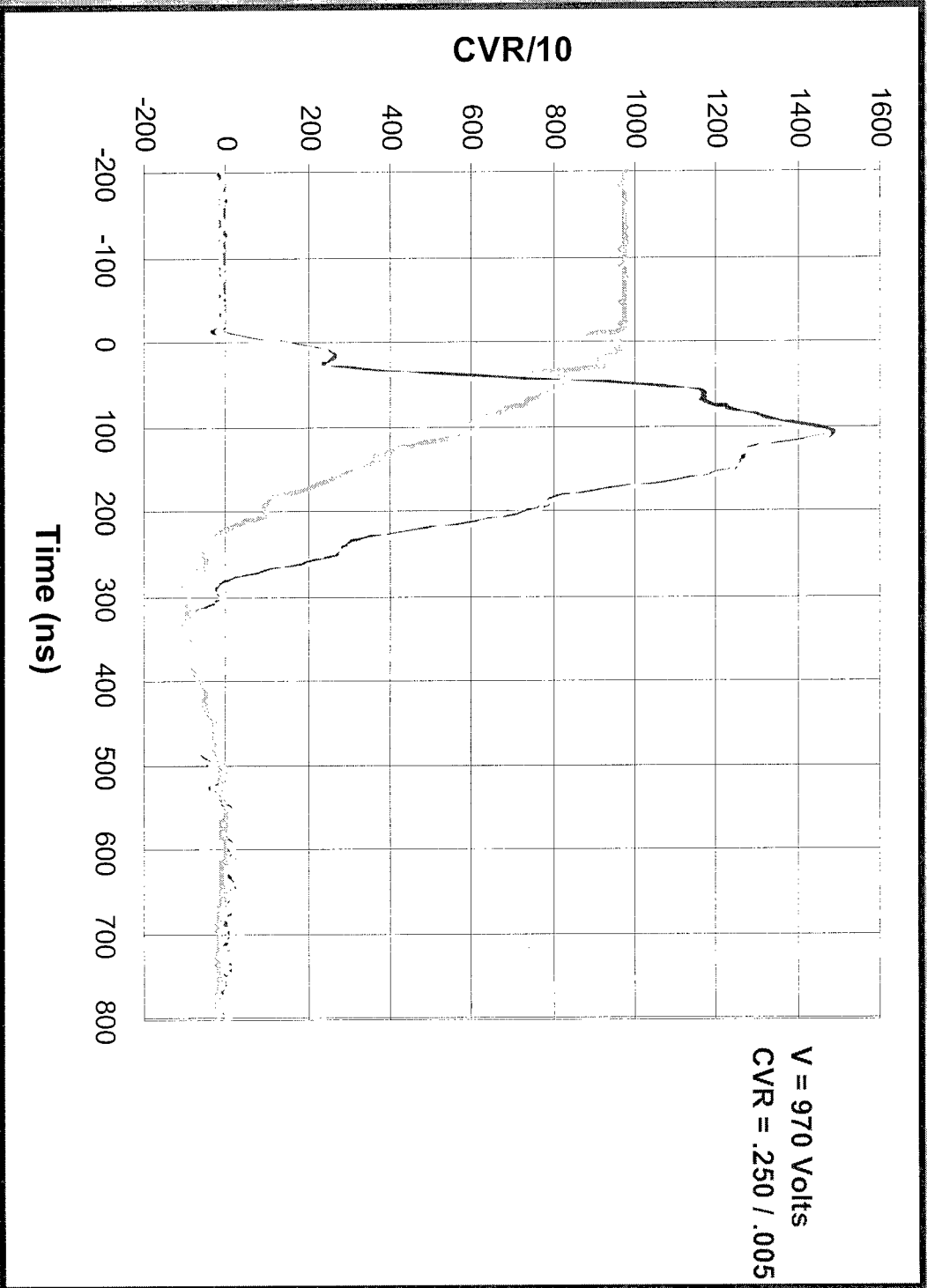
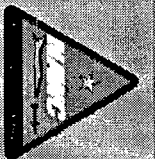



AVALANCHE VS. LINEAR

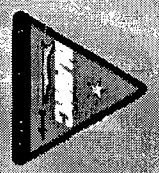

FET Switch Avalanche Vs Linear Functioning

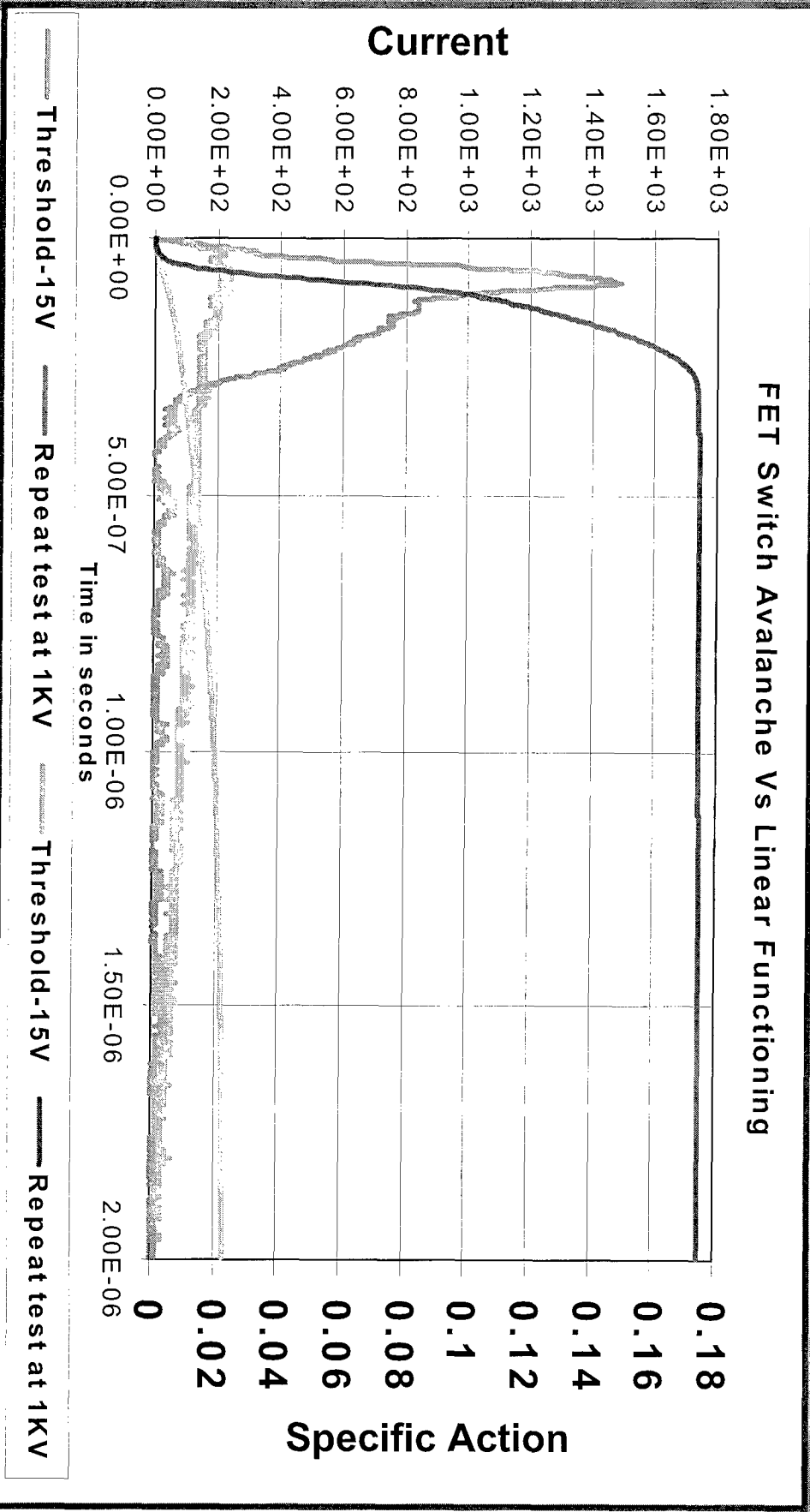



REMAINING TASKS

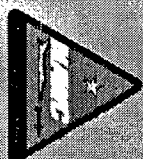

➤ FET Switch

✧ Fully Characterize Avalanche Operation

- ◆ Understand Any Failure Mechanisms
- ◆ Investigate Part to Part and Manufacture to Manufacture Variations
- ◆ Environmental Testing



REYNOLDS SYSTEMS INC.





REMAINING TASKS

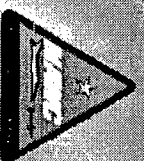

- **Explosive Material**
 - ✧ **Monitor Qualification Progress**
 - ✧ **Fabricate and Test**
- **Capacitor**
 - ✧ **Monitor Technology Advancements**
 - ✧ **Acquire Samples**
 - ✧ **Extensive Testing**





SUMMARY

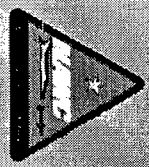

- **Firesets and Fireset Components Are Critical to the Performance of ESADs**
- **Advances in Technology Have Made Improvements Possible**
- **Test Data Has Shown That MOSFETs / NMCTs May Replace Spark Gaps in the Near Future**



REYNOLDS SYSTEMS INC.



43rd Annual Fuze Conference

6-8 April 1999

FUZZING FOR SPECIAL ENVIRONMENTS

Jim Sorensen PRIMEX Technologies

Ordnance and Tactical Systems Division

1840 Fairway Drive San Leandro, CA 94577

(510) 346 1887 fax (510) 346 1804

e-mail: jsorensen@san.prmx.com

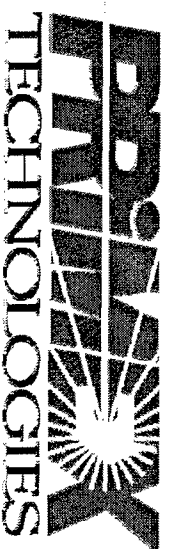

PEPZ Piezo Electro-Mechanical Fuze

Second Safe Mechanism

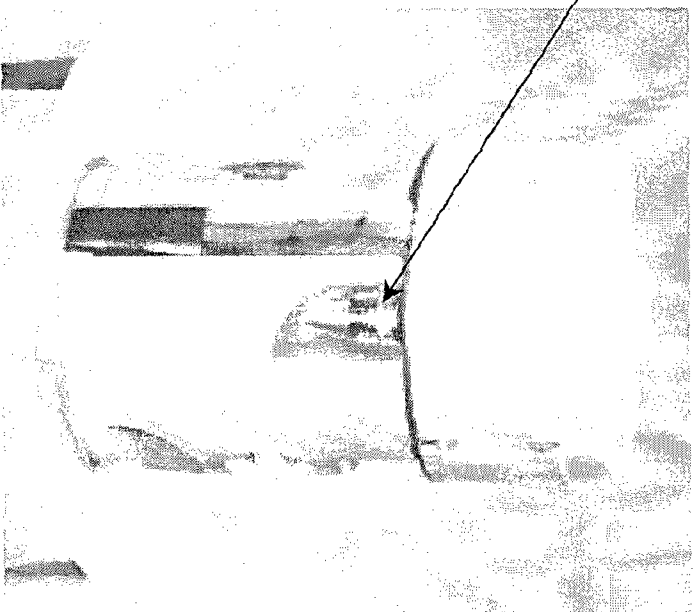

Rotor Escape Mechanism

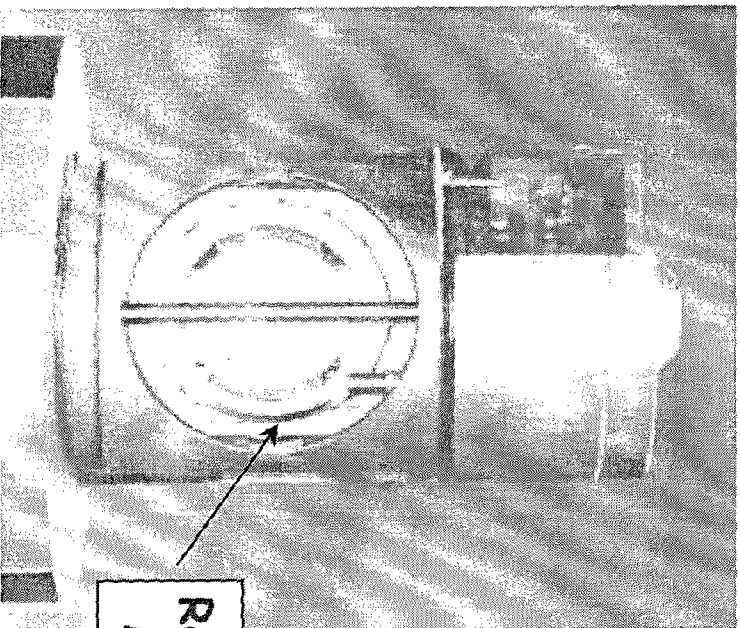

43rd Annual Fuze Conference



ACCELERATION/SHOCK PLOT

Main Charge FUZE

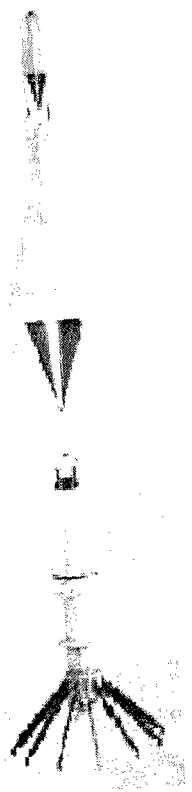
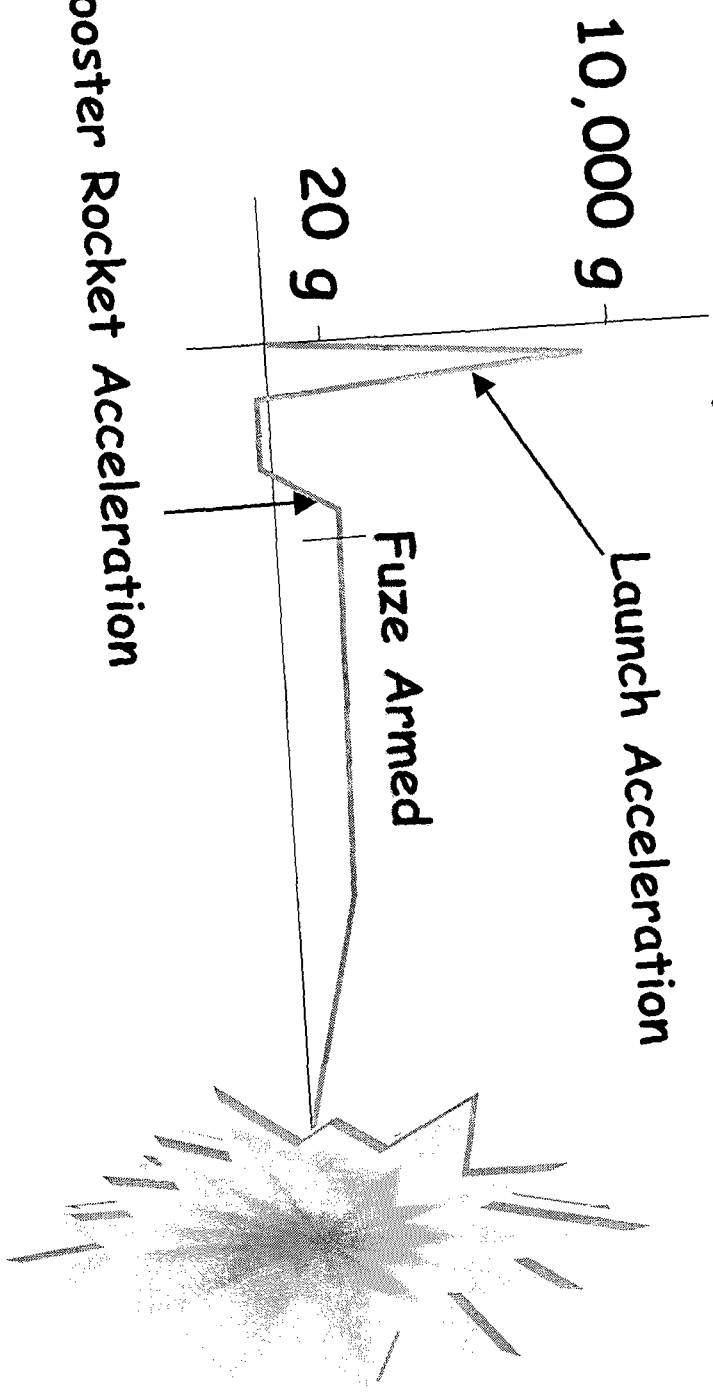

SYSTEM: Panzerfaust

FUZE: Piezo Electro-Mechanical



43rd Annual Fuze Conference

ACCELERATION PLOT *Artillery or Mortar*

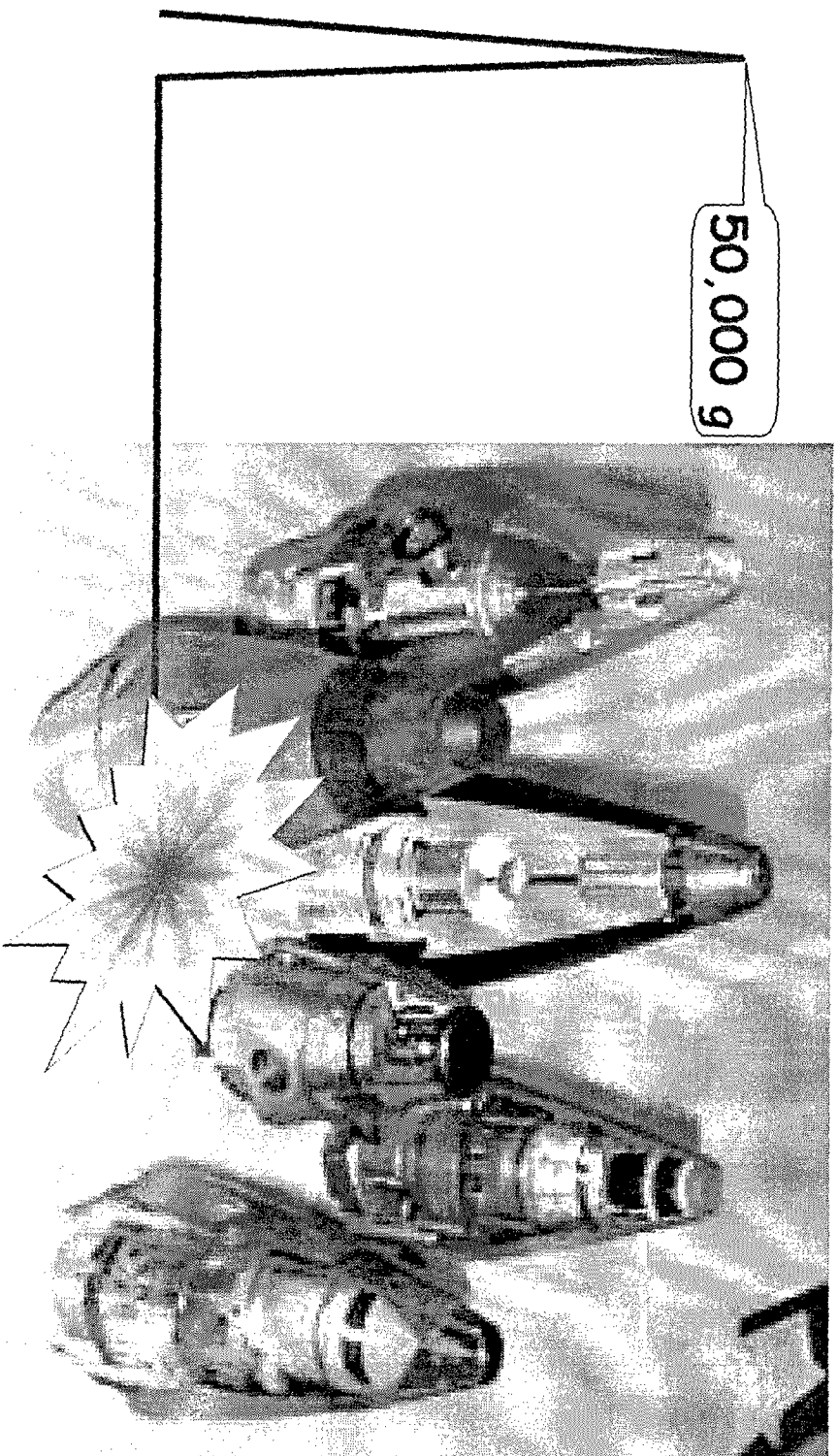

43rd Annual Fuze Conference



Bunkerfaust Uses Breaching Charge with Follow Through Anti-Personnel Grenade

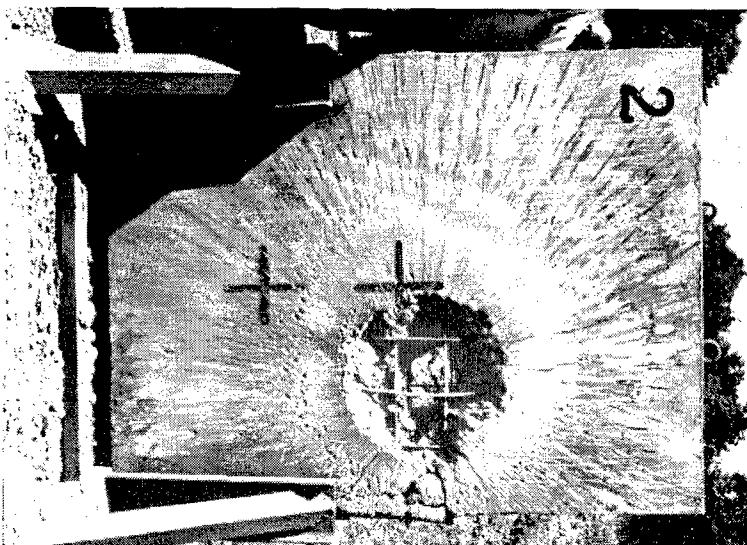
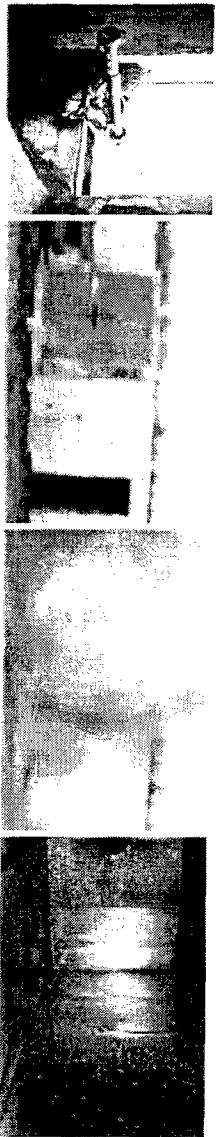
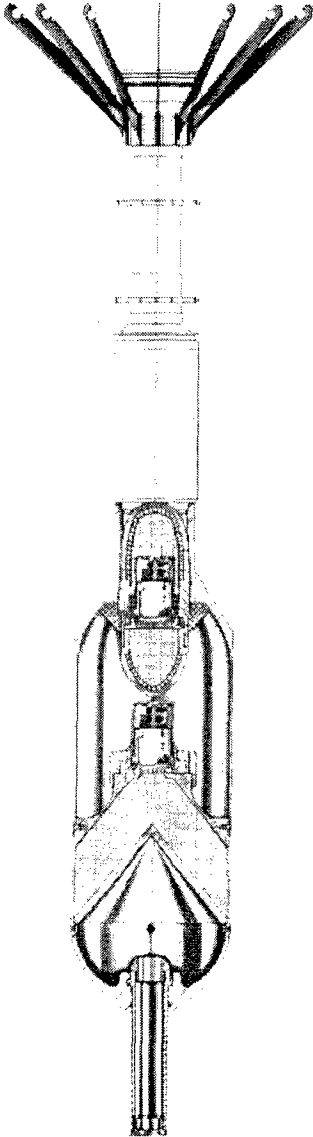
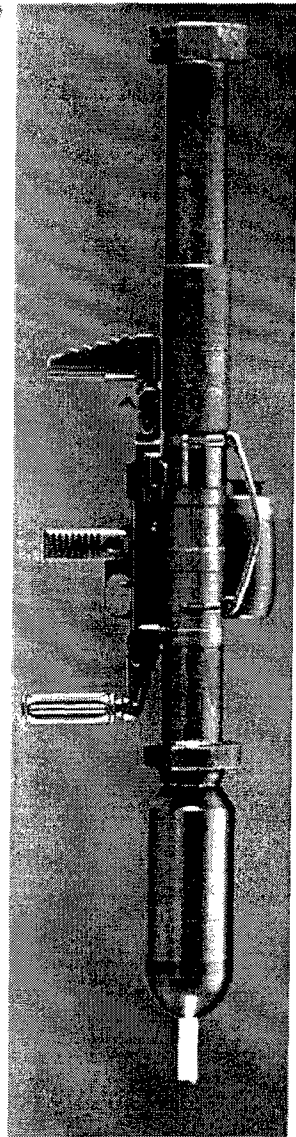

43rd Annual Fuze Conference



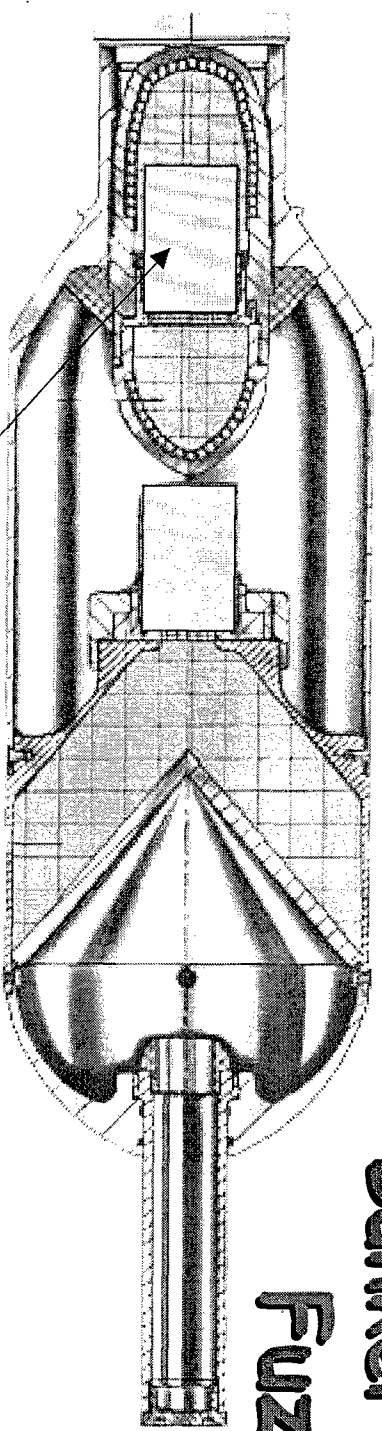

Bunkerfaust Fuze

ACCELEROMETER MEASURED \approx 134,000 g's

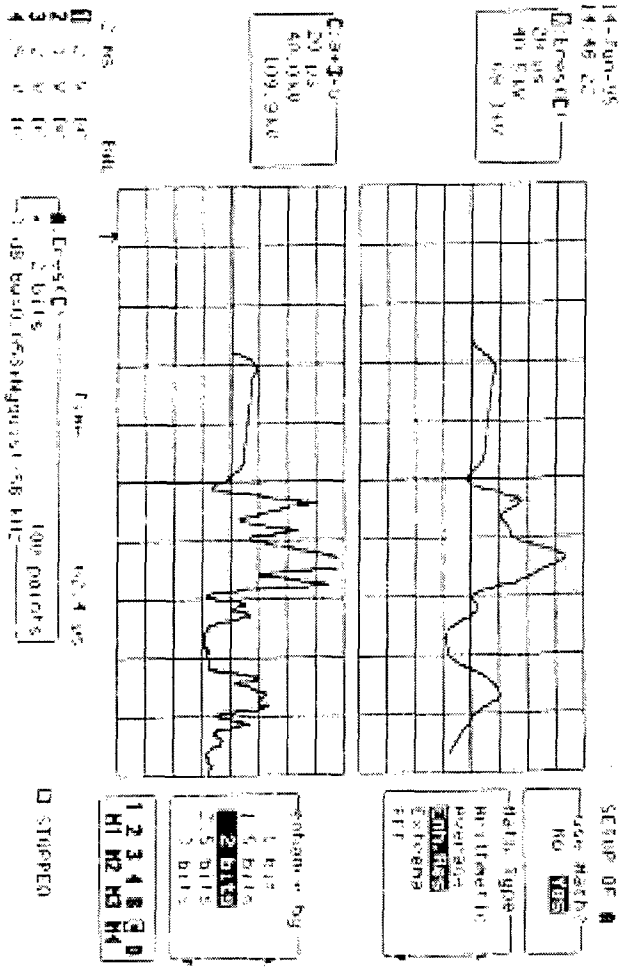

43rd Annual Fuze Conference



ACCELERATION/SHOCK PLOT

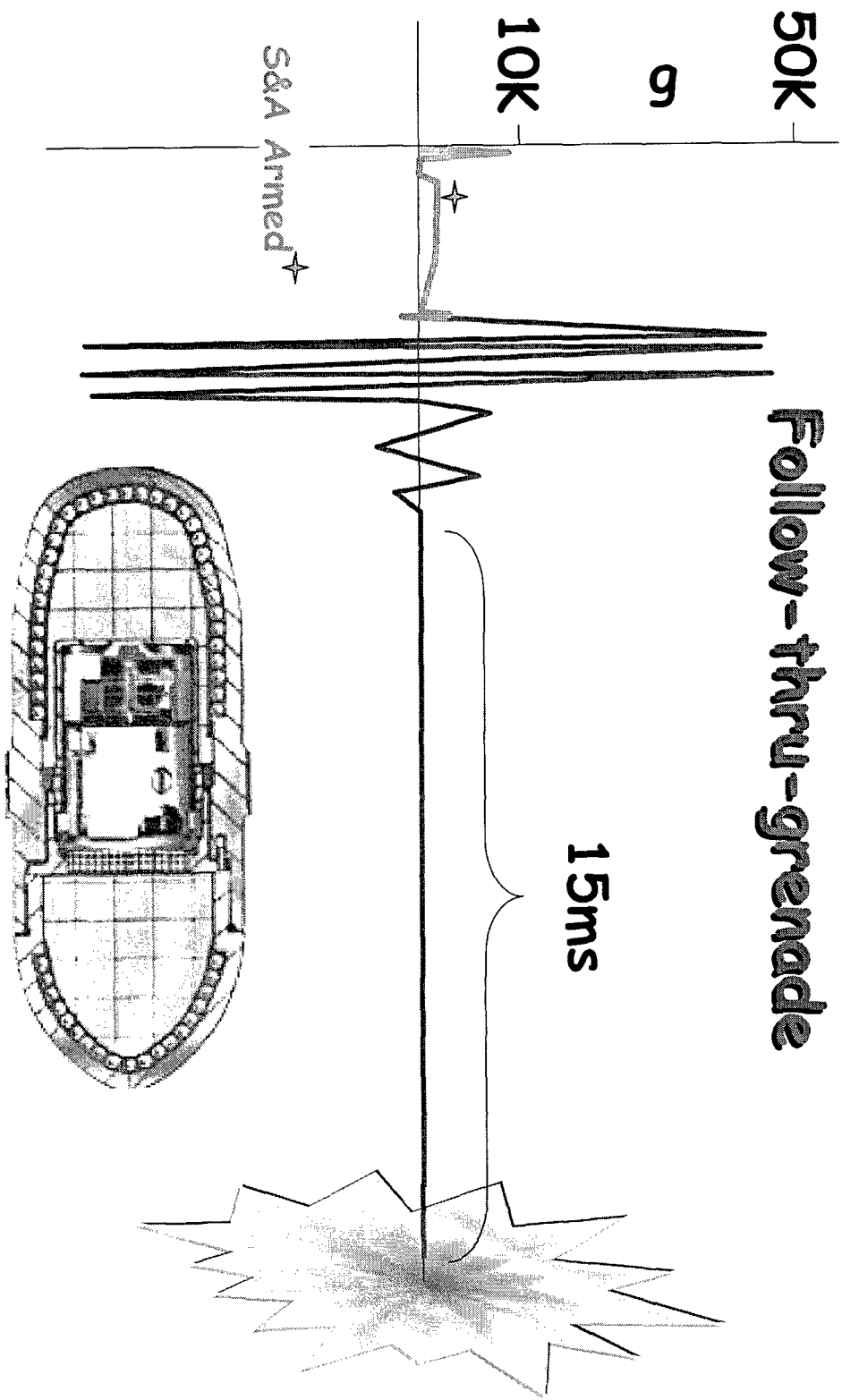

43rd Annual Fuze Conference



Problems that can be/were encountered

- 1. Electrical contact breaking between electronics and detonator**

TYPES OF ELECTRICAL CONTACTS

KNIFE BLADE

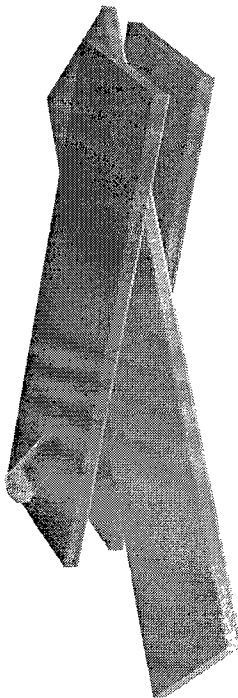

COPPER SPRING



SPRING LOADED PIN ON PIN

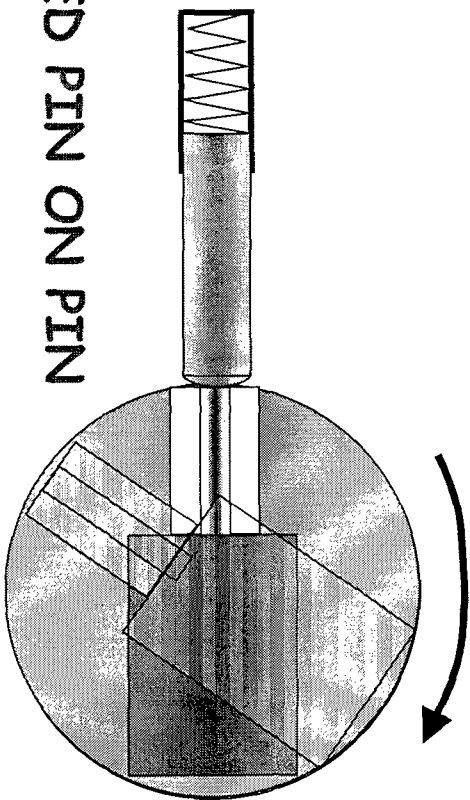

43rd Annual Fuze Conference



ELECTRICAL CONTACT SOLUTION

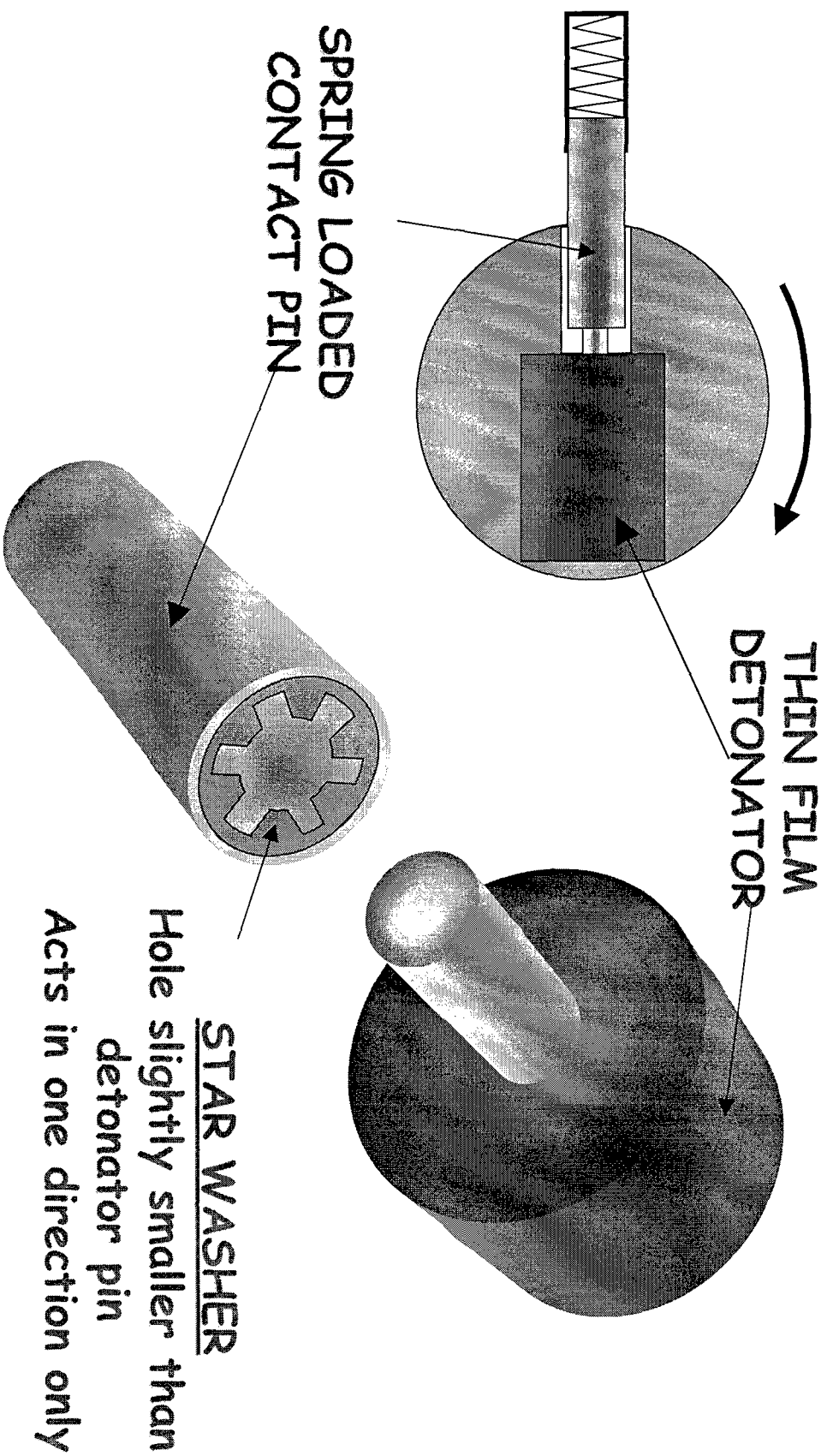

43rd Annual Fuze Conference



Problems that can be/were encountered

1. Electrical components making problems for the
and generator

2. Circuit boards break, SMC solder break/cracks



MODIFIED CIRCUIT BOARDS & MOUNTING PROCEDURES

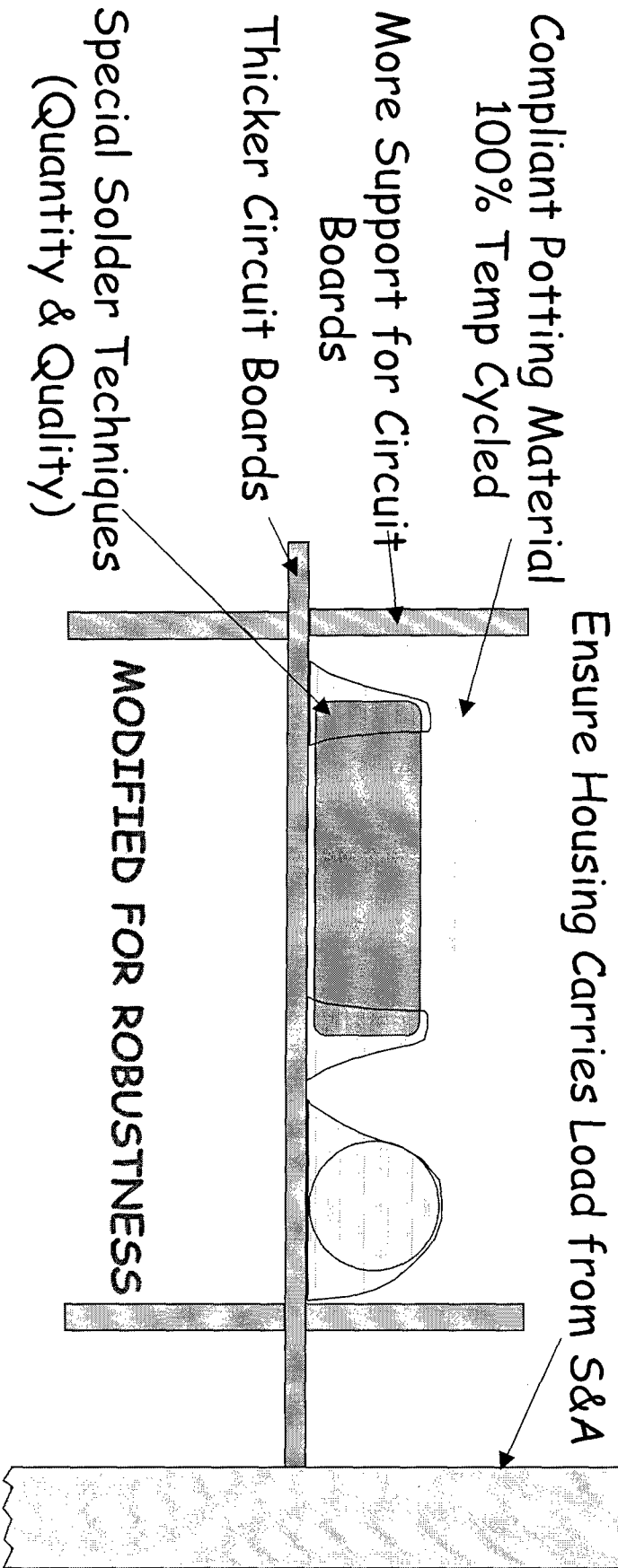
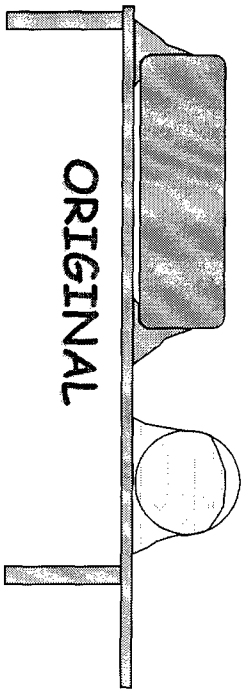

43rd Annual Fuze Conference



Problems that can be/were encountered

1. Poor electrical contact in parallel or series wire connections of detonator
2. Cr. wire boards break, =ARC shaver breakers or shes
3. Detonator explosives compacting making gaps
4. Detonator bridge wire breaking

SOLUTIONS

1. Different cost of design incorporation (Still use cost)
2. All still use similar process and components. Significant change in board's method of mounting is needed for electronics

3. Use thin film detonator

Problems that can be/were encountered

1. Electrical problems at various design/production levels
2. Circuit boards break, SW. reliability issues/bugs
3. Retarder expl. silver compounds making glass
4. Retarder's bridge wire failure
5. Parts failure --Not robust enough
6. Piezo failure --cracking due to overload

SOLUTIONS

Review component designs.

You will use 3D models to specify and analyze properties of circuit boards, components, mounting procedures, and electrical systems.

Use electrical simulation software.

Design for load.

Material specification change. Mass design

Follow-thru Grenade Sequence

1



2



3



4



Total time ~ 15 ms

43rd Annual Fuze Conference



TECHNICAL SPECIFICATIONS

(in production)

Diameter (in aluminum case)

29 mm

Height (in case)

39.5 mm

Weight (in case)

60 grams

Safe & Arm Mechanism

2 independent safeties

Detonator

Type ZP-81-7 (DM 1461)thin layer
(100 \pm 20 Ohms)

Function

All Fire \geq 90V at 2 nF (on detonator pin)
No Fire \leq 20V at 2 nF (on detonator pin)

Charge

Primary 55 mg Silverazide
Secondary 60 mg PETN

43rd Annual Fuze Conference



NEW DEVELOPMENTS

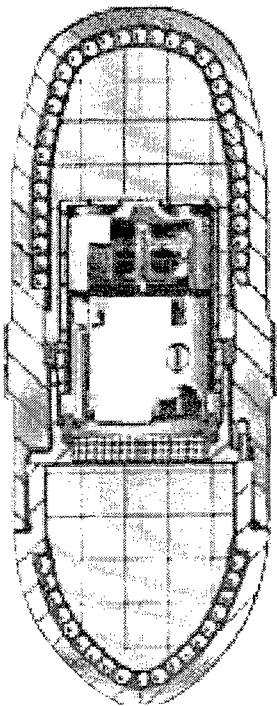

Standard S&A (29mm diameter in aluminum case)

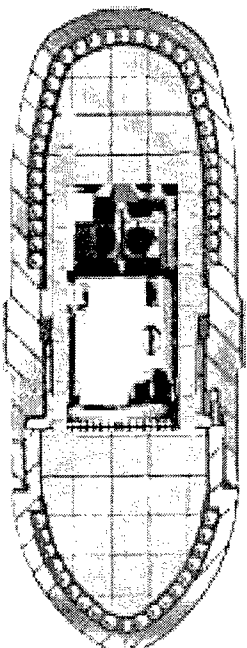

New Fuze & Grenade
(about 20mm dia with slightly smaller grenade)

TECHNICAL SPECIFICATIONS

(in development)

Diameter (in aluminum case) 18mm
Height (in case) 39.5mm
Weight (in case) 40 grams

Safe & Arm Mechanism 2 independent safeties

Detonator Type ZP-78-5 thin layer
(100 ± 20 Ohms)

Function All Fire ≥ 90V at 2 nF (on detonator pin)
No Fire ≤ 20V at 2 nF (on detonator pin)

Charge Primary 15 mg Silverazide
Secondary 20 mg PETN

43rd Annual Fuze Conference



43rd Annual Fuze Conference
6-8 April 1999

FUZZING FOR SPECIAL ENVIRONMENTS

by

Mr. Ruedi Zaugg Zaugg Elektronik, Switzerland
Mr. Markus Joost EMS Patvag, Switzerland
Mr. Jim Sorensen* PRIMEX Technologies, USA

Z A U G G

E L E K T R O N I K

EMS

EMS-PATVAG AG

PRIMEX
TECHNOLOGIES

Detonator Technology for Special Environments



Markus Joost

Overview

- **The detonator as the interface between electrical and pyrotechnic energy**
- **Standard requirements for a detonator**
- **Bridge-Wire Detonators, the proven technology**
- **Special requirements for detonators**
- **Thin-Film detonator technology as an alternative**
- **Bridge Wire vs. Thin film**
- **Key Components**
- **Reference projects with special requirements**
- **Future designs**



The detonator as the interface between the electric and the pyrotechnic energy

Ignition Train

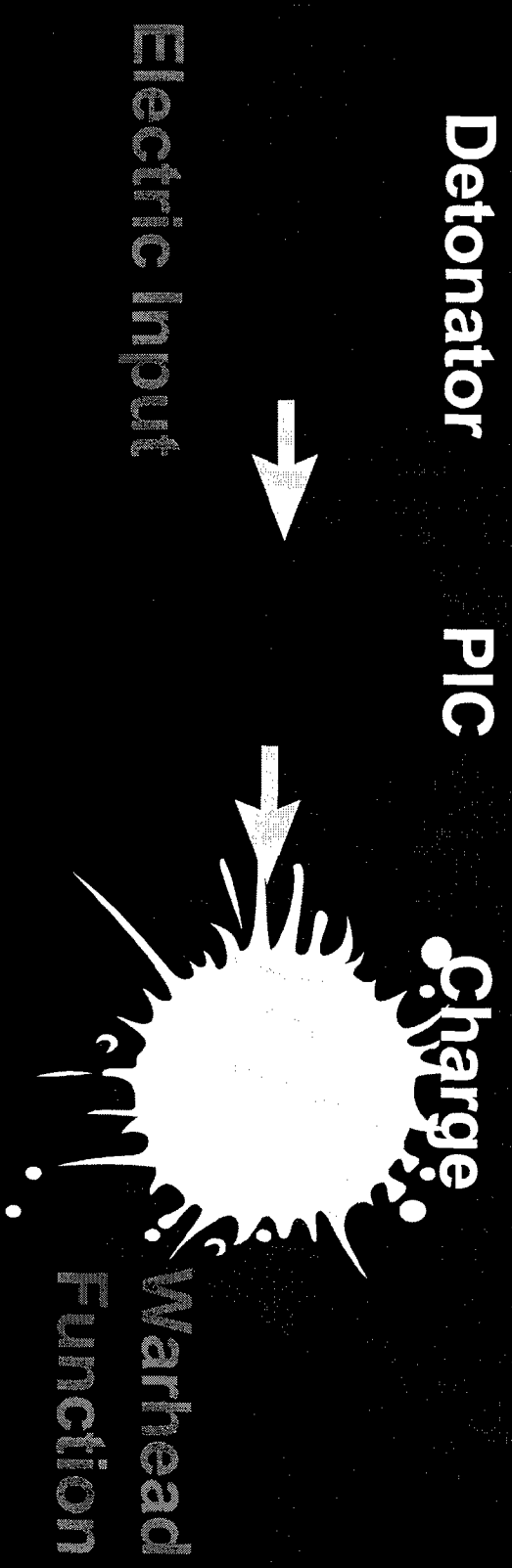

E

Standard requirements for a detonator

- **Correct functioning**
- **Small in size**
- **Ability to affect the environment for a safe handling**
- **Fast response, short delay time**
- **No restrictions after environmental testing**
- **Long life**
- **Low price**



Bridge-Wire Detonators, the proven technology

- **General advantages**
 - > **Standard technology for more than 40 years**
 - > **Many different types, sizes and applications**
 - > **Low cost when produced in high numbers**

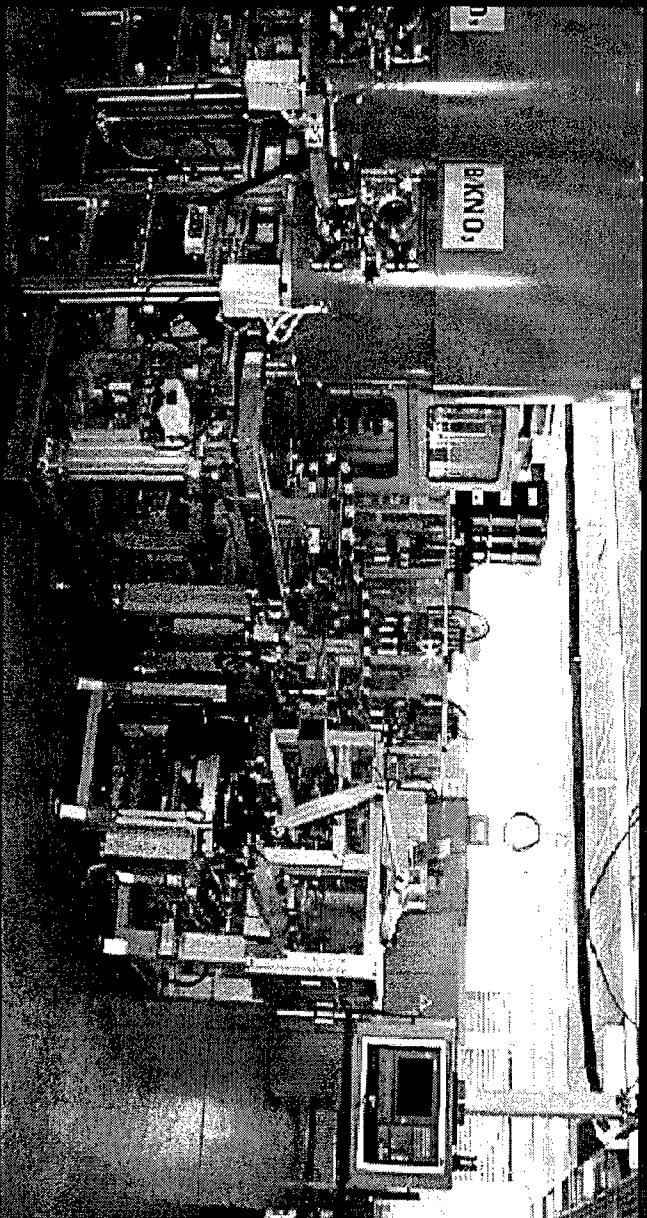

Bridge-Wire Detonators, the proven technology

- **General disadvantages**
 - > **Critical welding process to manufacture the wire-bridge**
 - > **Limited in withstanding high acceleration and spin-rates**
 - > **Limited in a minimal firing energy**



Special requirements for detonators

- Very low firing energies (<100μJ)
- Ability to withstand accelerations up to 100'000 g
- Ability to withstand spin-rates up to 120'000 rpm
- Very small in size

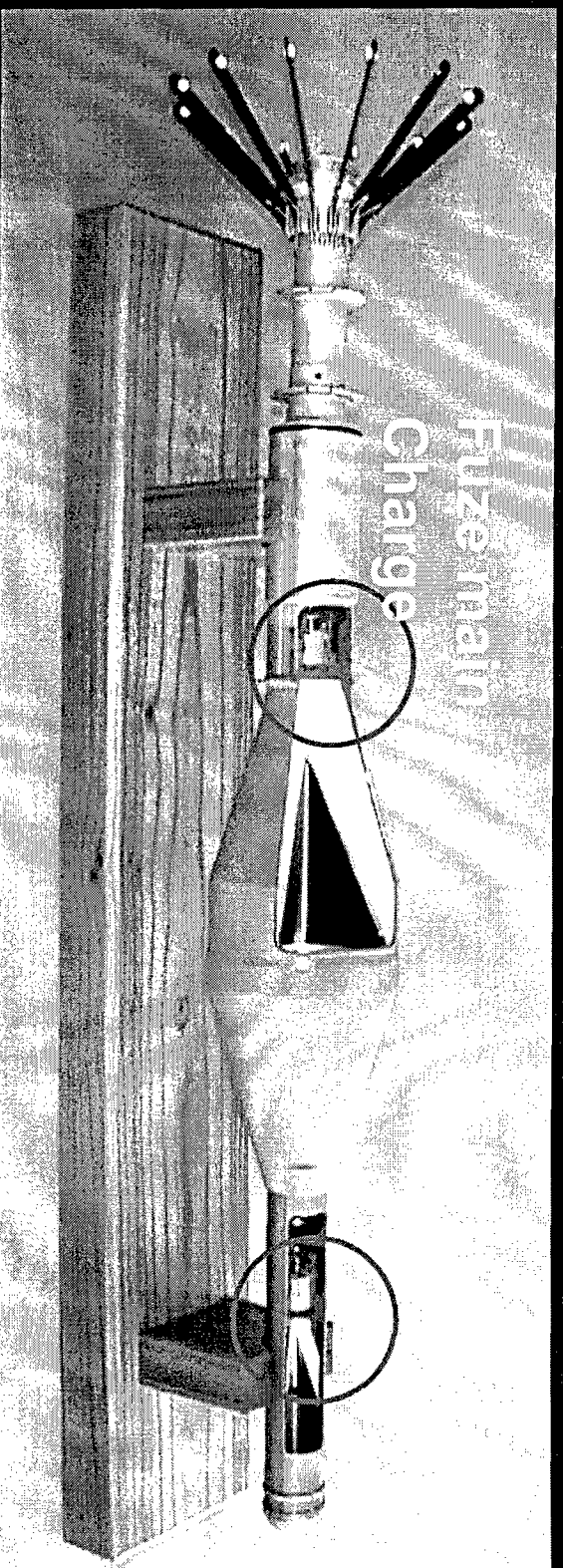

Example: Swiss Panzerfaust, Tandem Warhead

Thin film technology as an alternative to meet special requirements

- **Typical Firing energy of 40 μ J**
- **Low bridge mass gives ability to withstand up to 100'000 g**
- **Symmetric bridge design gives ability to withstand more than 100'000 rpm**
- **The design passes the environmental tests according to MIL- STD 331 & 810**



Bridge-wire vs. Thin-film

- The thin film has no welding process
- Thin film better withstands rough handling
- Thin film requires more manufacturing steps
- Thin film is less sensitive i.e. no broken bridges

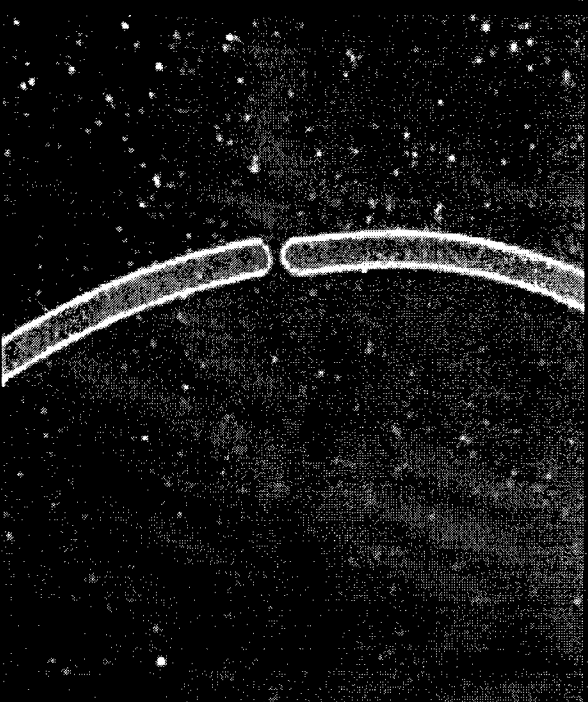
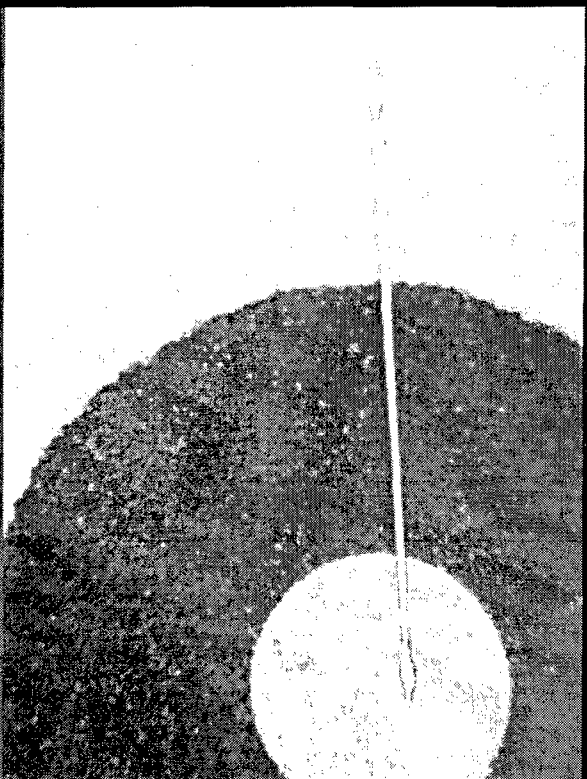

Key-Components: Detonator Pole-Piece

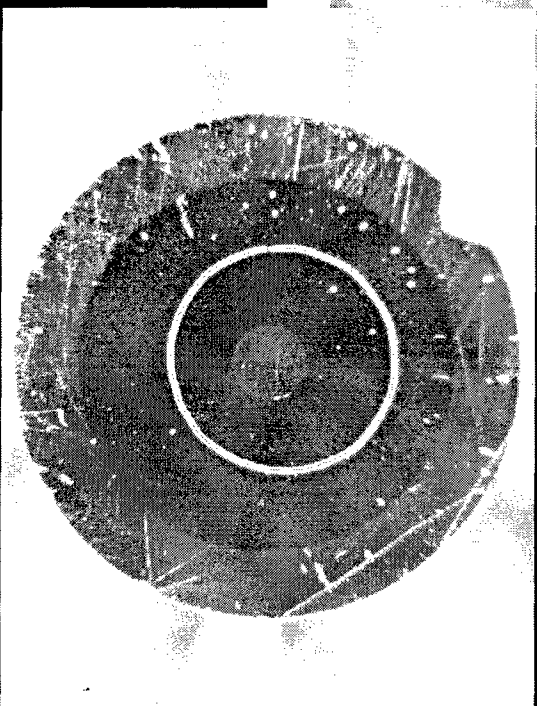
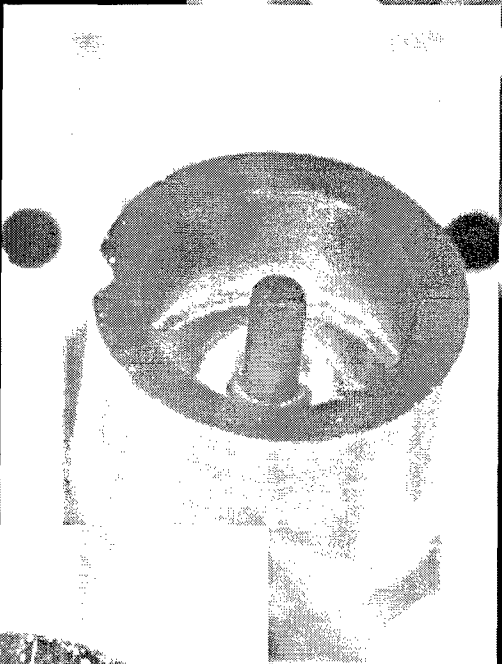
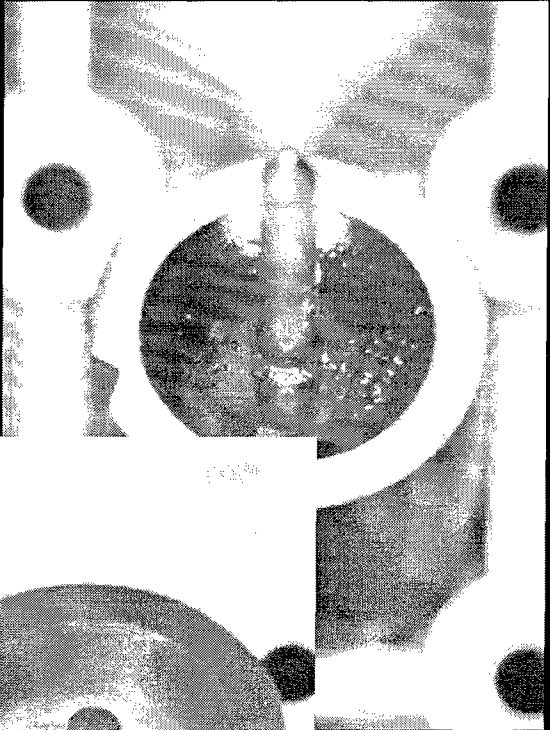

Glass to metal sealing

Polishing process
Vapor deposition

Laser cut resistance



Key-Components: Silverazide vs. Leadazide

- AgN₃ and PbN₃ are about equal in friction sensitivity
- The electrostatic sensitivity of AgN₃ is about 10 times less than that of PbN₃
- With AgN₃ is no danger for a chemical forming into Copperazide
- The relative energy output of AgN₃ is higher than of PbN₃
- AgN₃ has very good chemical stability
- Handling of AgN₃ is more sensitive than PbN₃ during manufacturing



Reference Projects with thin film technology

Detonator for Mauser-Aircraft Gun (Tornado)

- Detonator withstands extremely high g loads
- Detonator withstands 105'000 rpm
- More than 400'000 pcs have been manufactured successfully

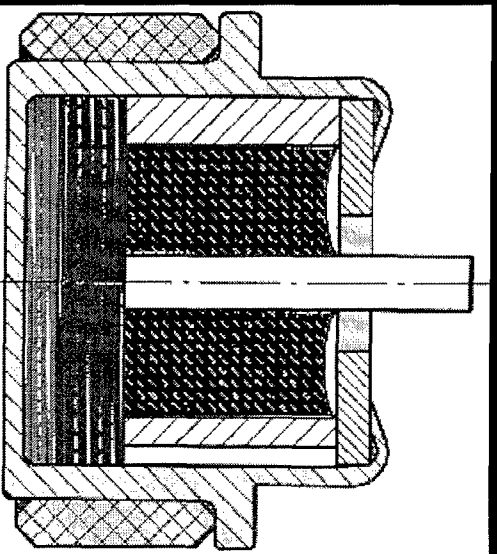

DM1267

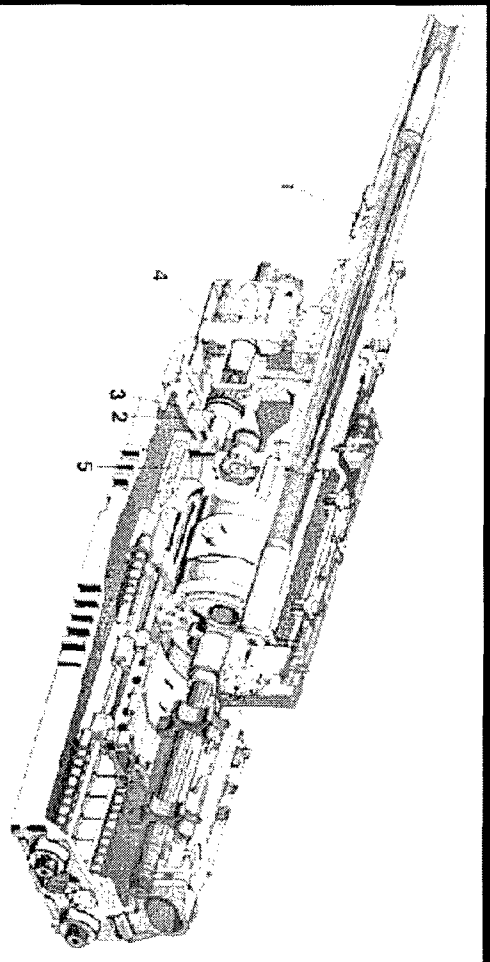

Mauser 27 mm Aircraft Gun

Reference Projects with thin film technology

Detonator DM1461 used in the German Bunkerfaust

- The Detonator in the follow through grenade withstands >50'000g
- More than 300'000 detonators of this type are manufactured for different projects

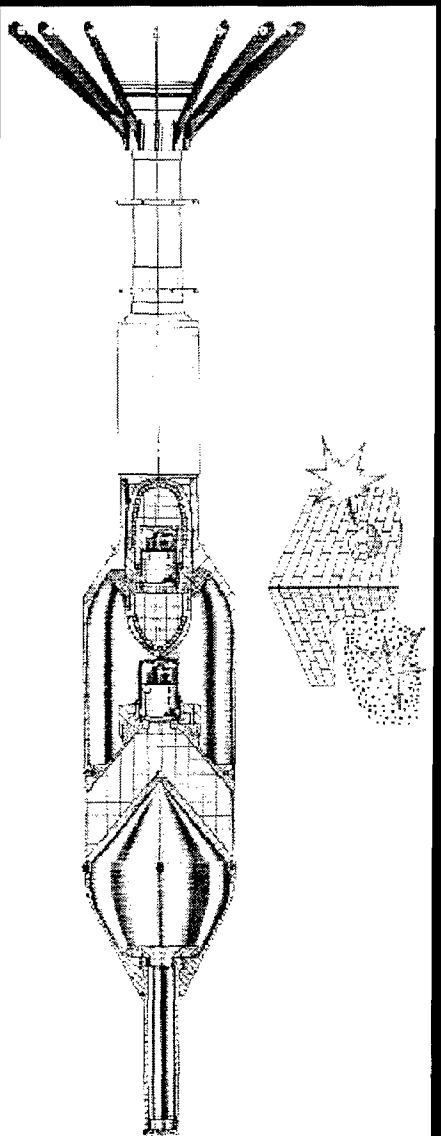

Bunkerfaust Dynamit Nobel / Diehl

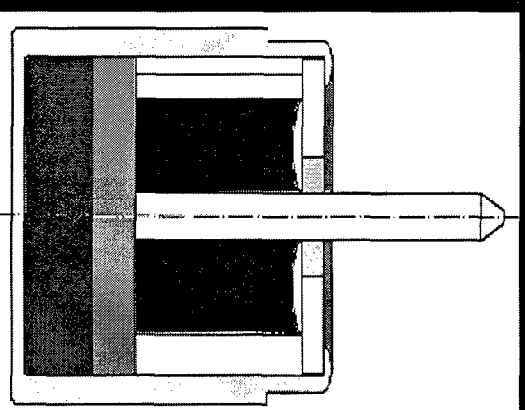

DM1461

Future Designs for Thin film detonators

-
- **Use in Ammunition with high acceleration up to 100'000g**
- **Use in Ammunition with high spin rates up to 120'000 rpm**
- **Thin film technology can be used in miniaturized Fuze systems for small warheads and future Airbag igniter designs.**



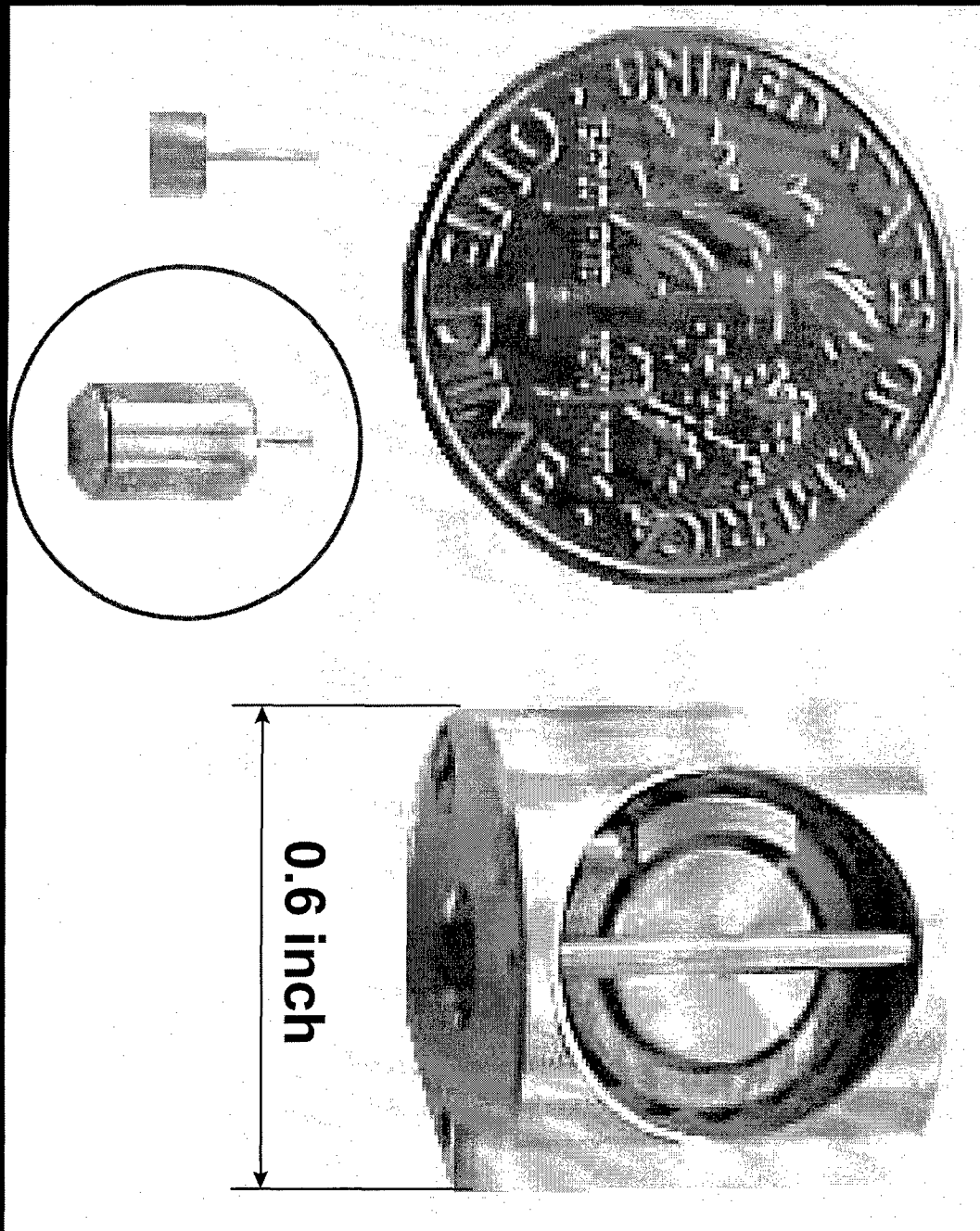

Summary

- **Thin film technology is a high quality alternative to the standard Bridge wire-technology**
- **For special requirements like high acceleration or high spin rates the ballistic and energy advantages of the thin film are much more than those of a bridge wire detonator**
- **The thin film technology is a well proven method in use for more than 15 years.**

SABRE's Water Sensing Fuze

for



8 April 1999

Keith Lewis
Matthew Sanford

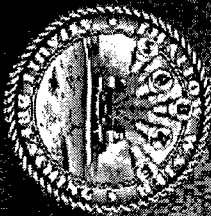
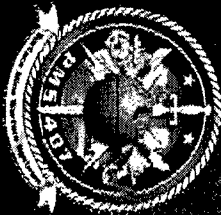



System Overview

Clears Mines &
Obstacles from
Shallow Water

- Rocket propelled
- 400' long
- 1300 lb explosives

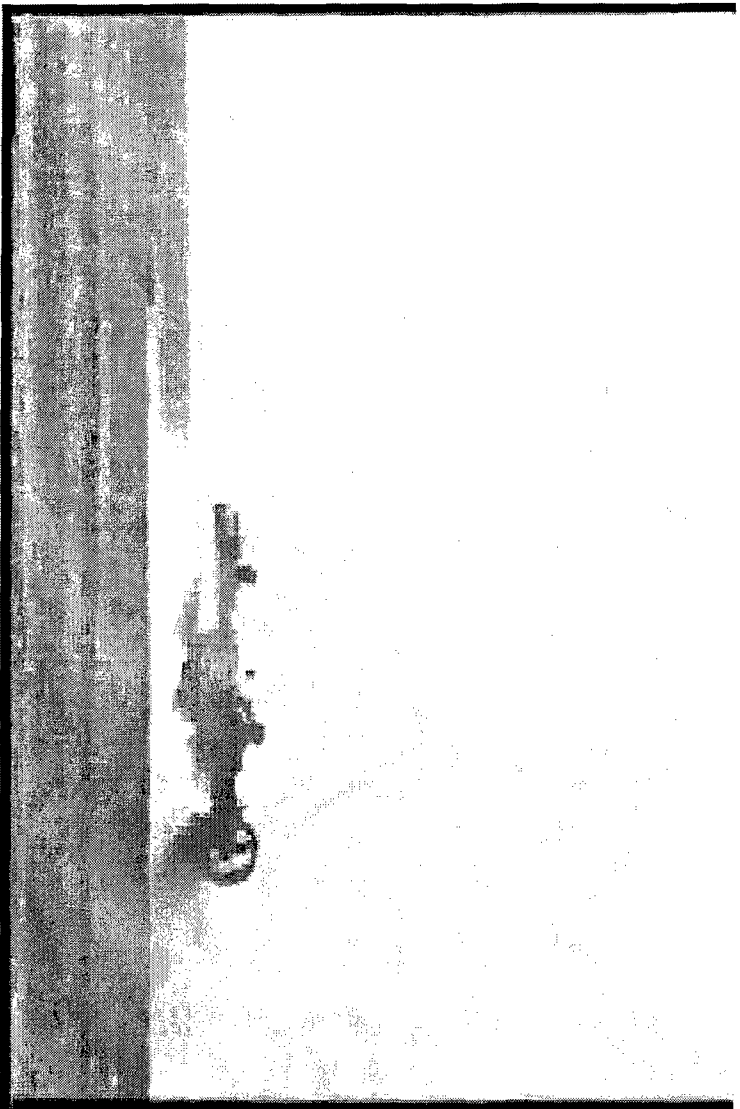

History

- SABRE originally from the beach
- Operators moved back for launch

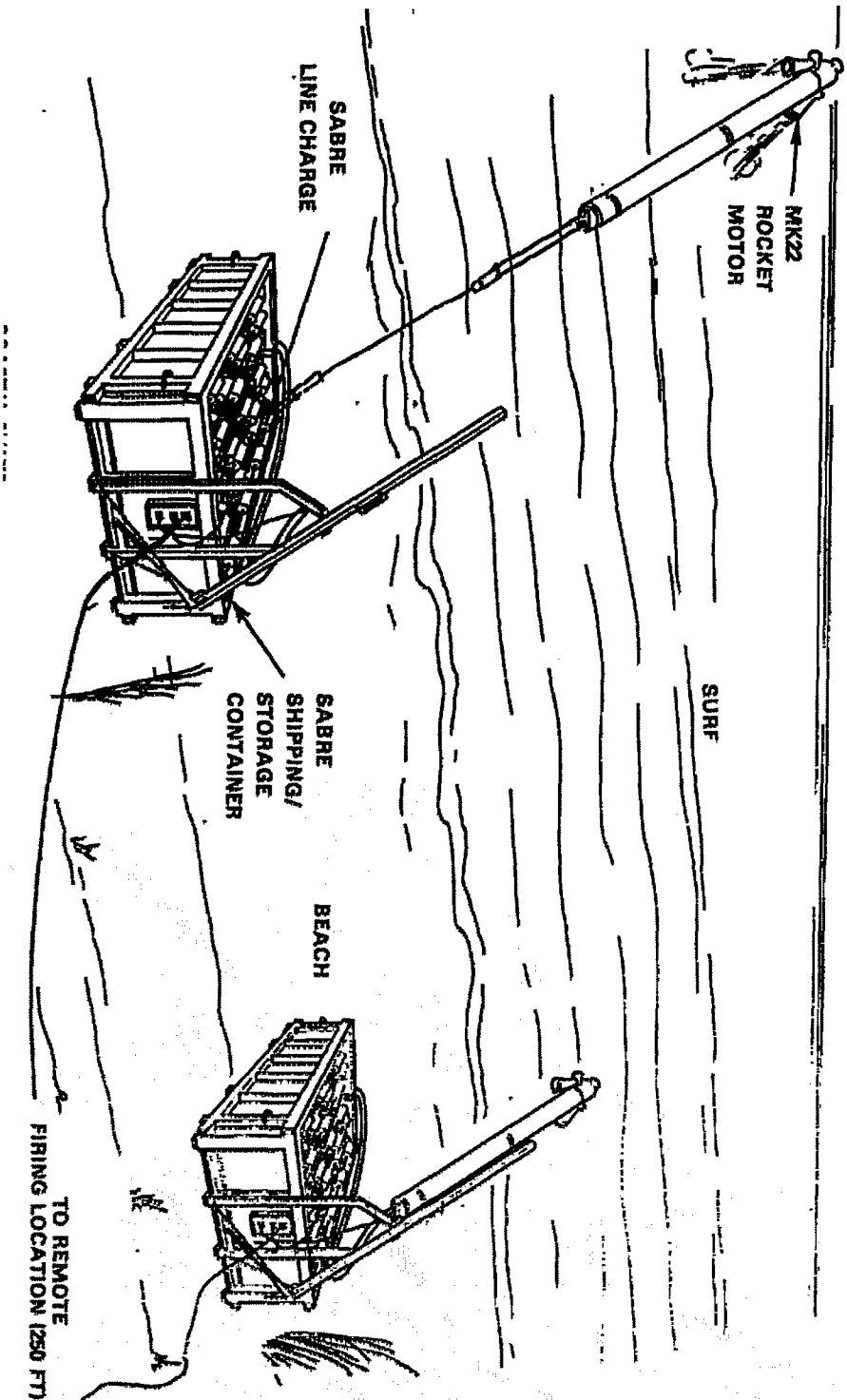

Original SABRE Fuze

- Lanyard to arm in-air
- Simultaneously initiates 13-second delay detonator

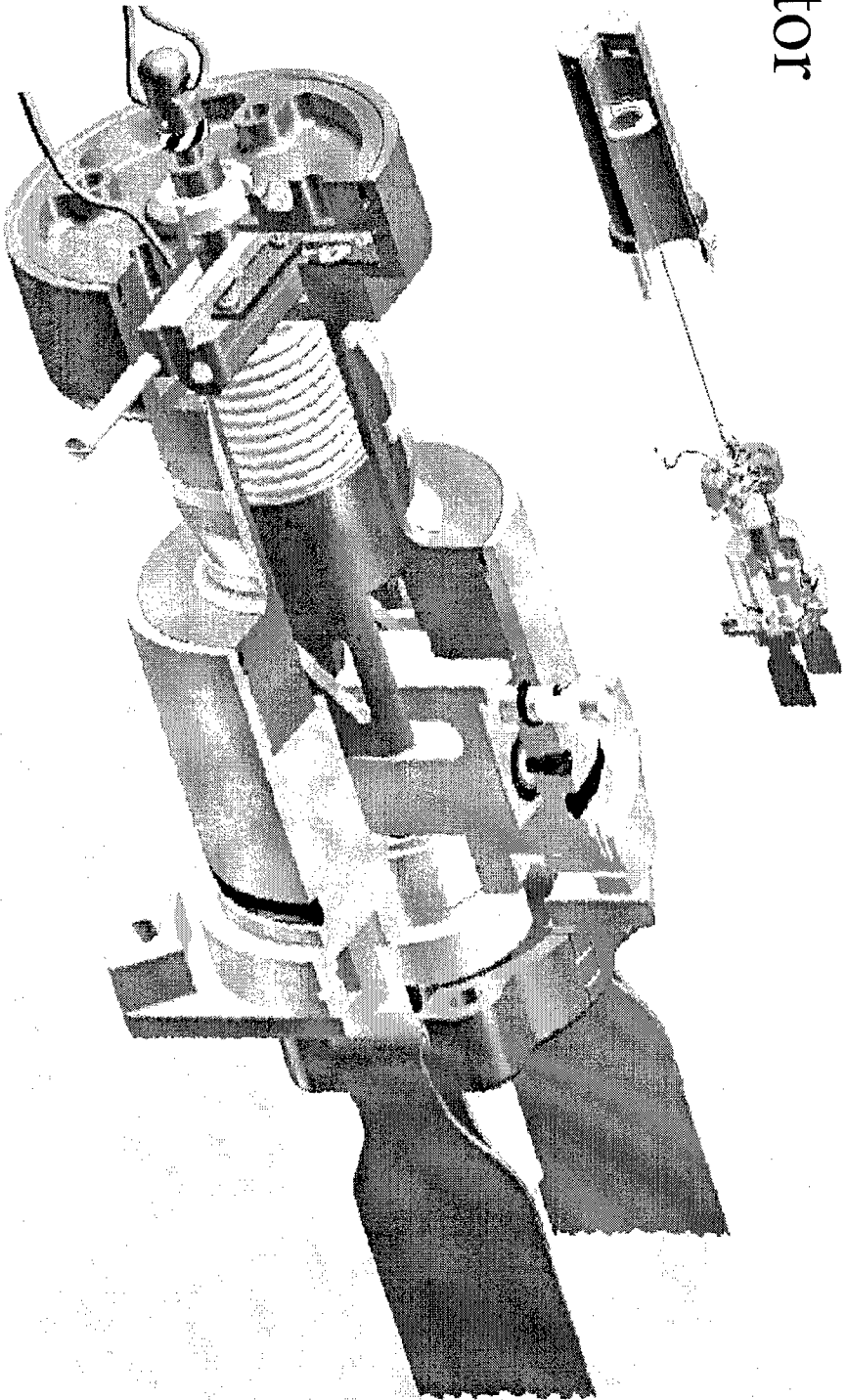



SABRE on the LCAC

- Class A asset raises safe separation concern
- Analysis & testing begun

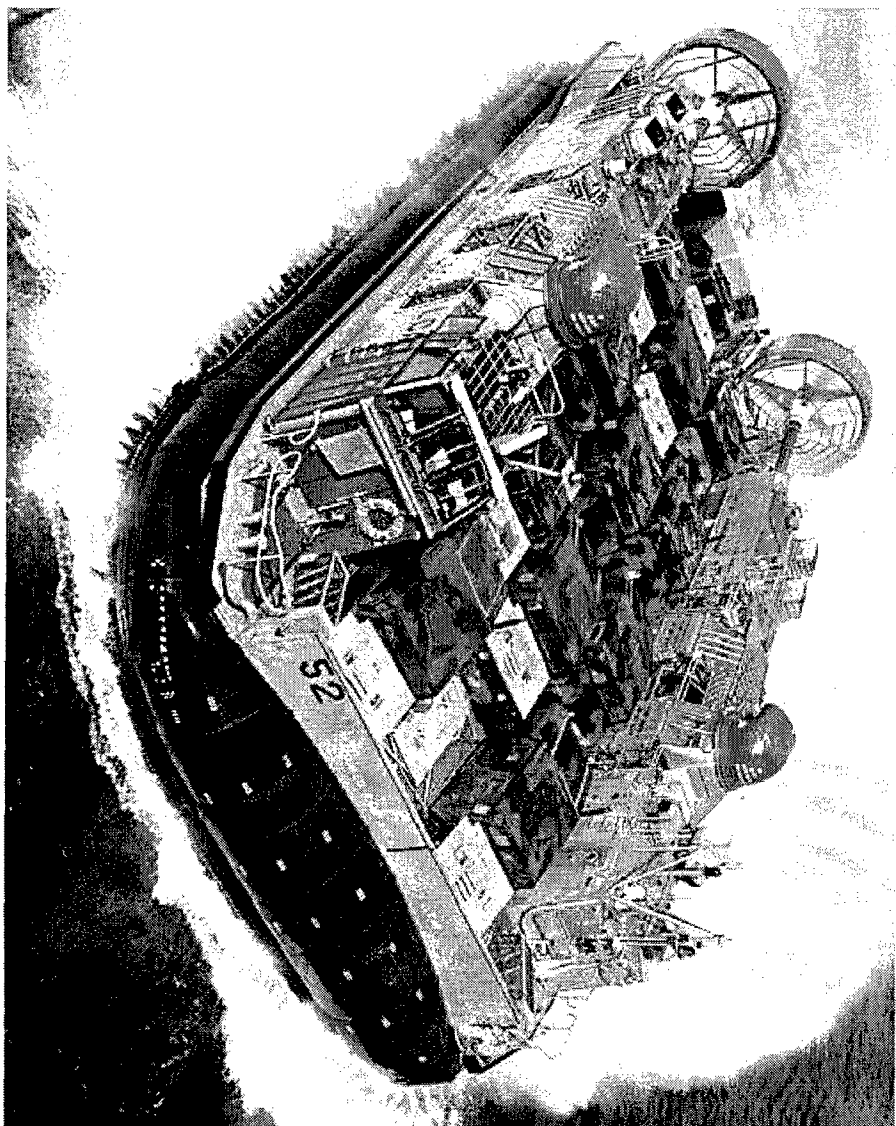

Safe Separation

- Difficult to quantify
- Focus on threat/risk/hazard

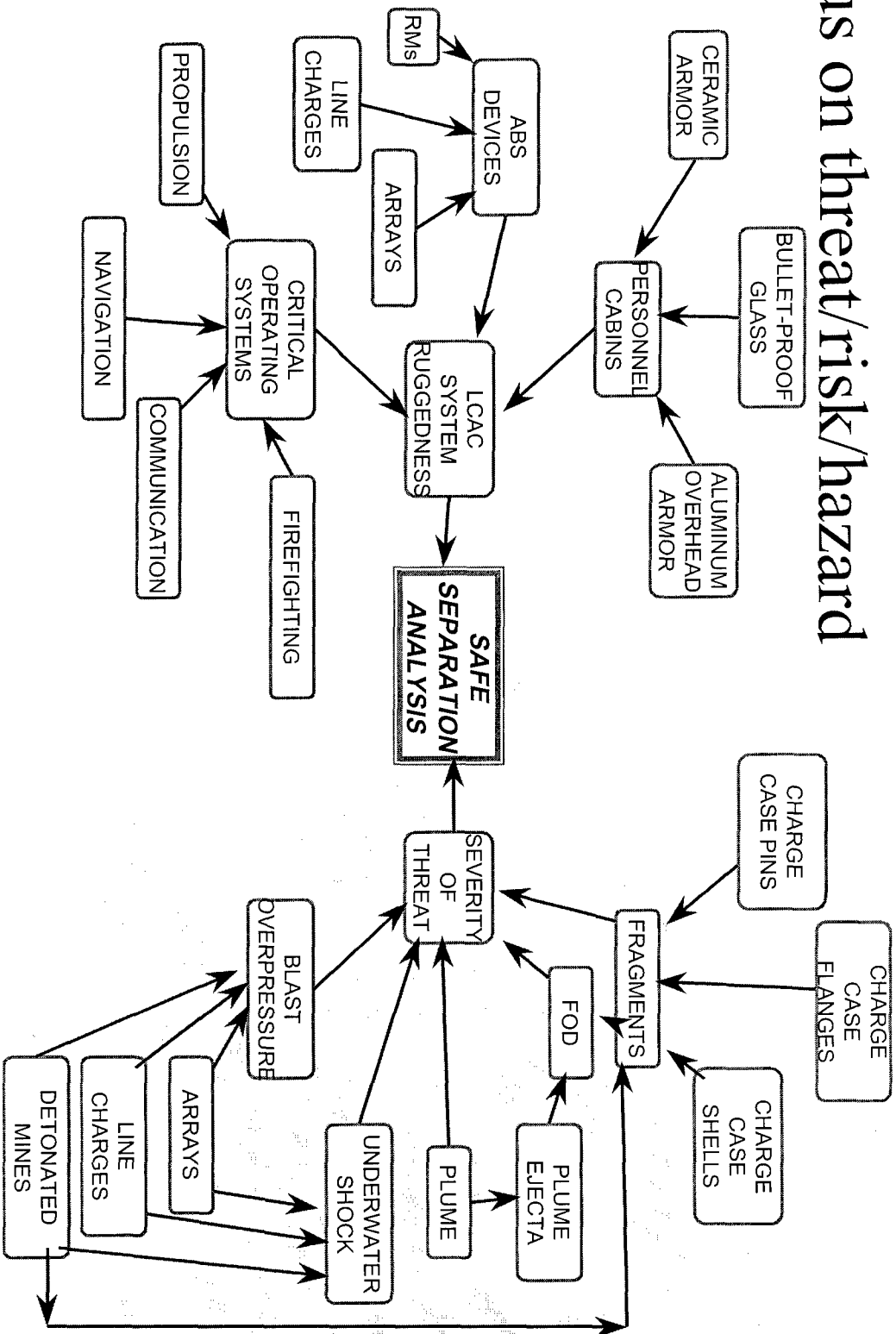



LCAC at Risk

- Risk from fragments
- Arms inside safe separation
- Rate of premature function unknown

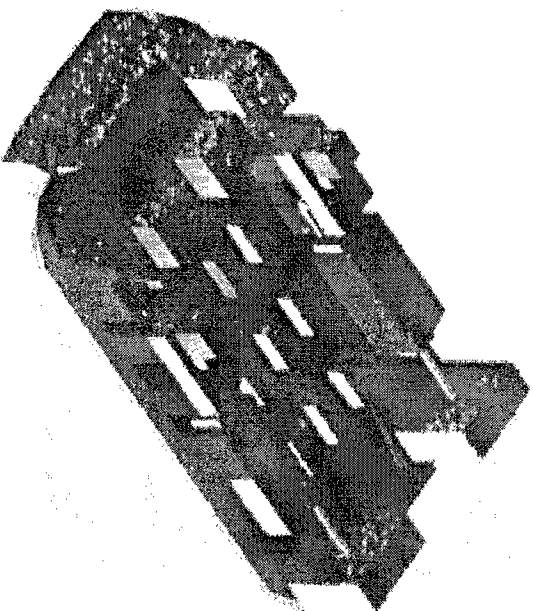
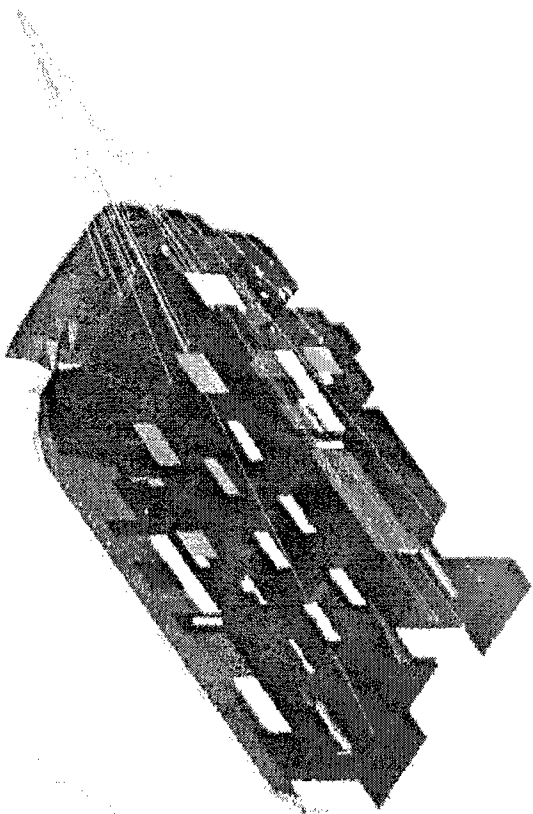

Solution Approach

- Examined numerous approaches
- Decision to modify fuze

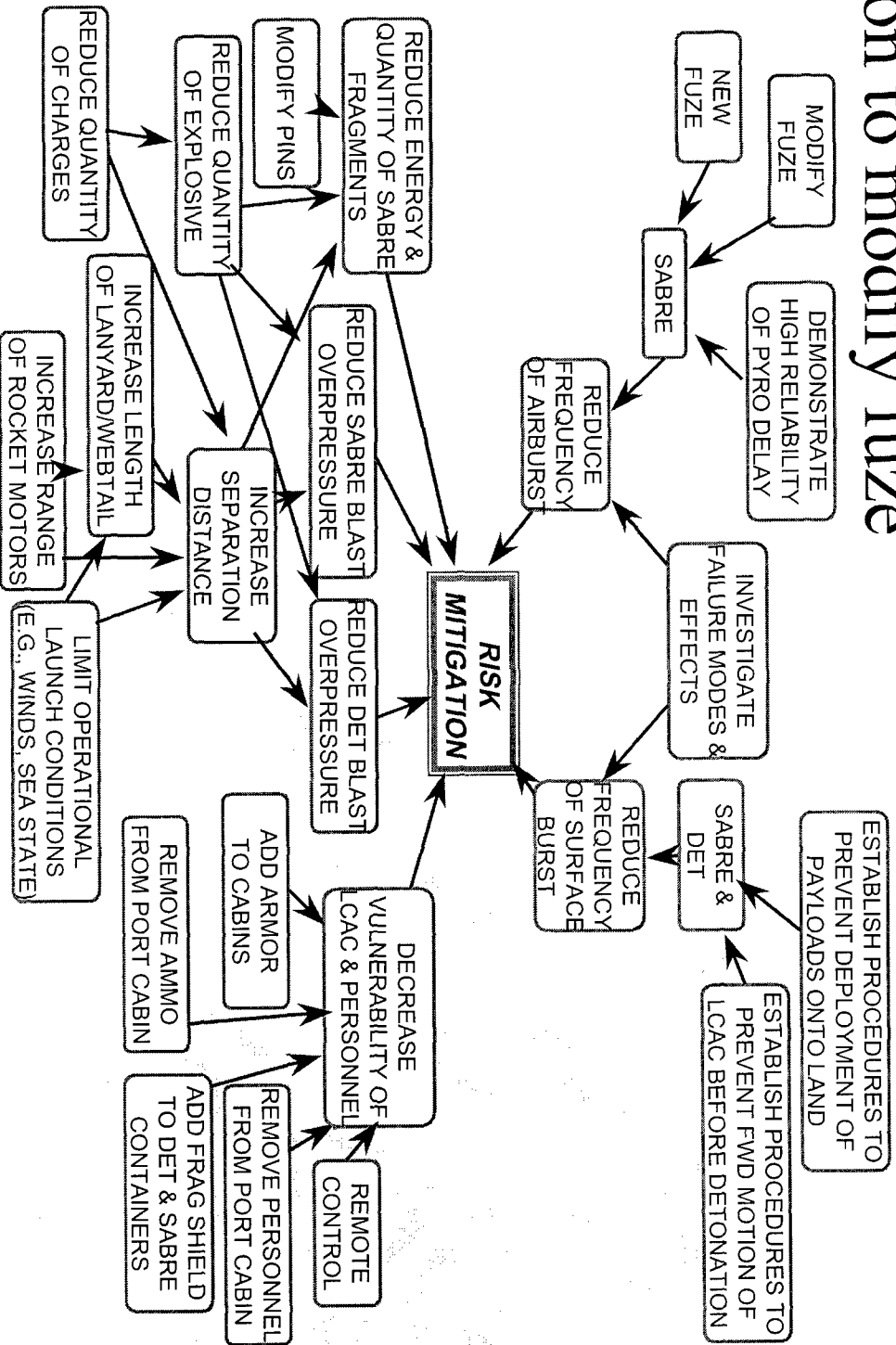

New SABRE Fuze

- Use the water as an environment
- Redesign and qualify in 17 months

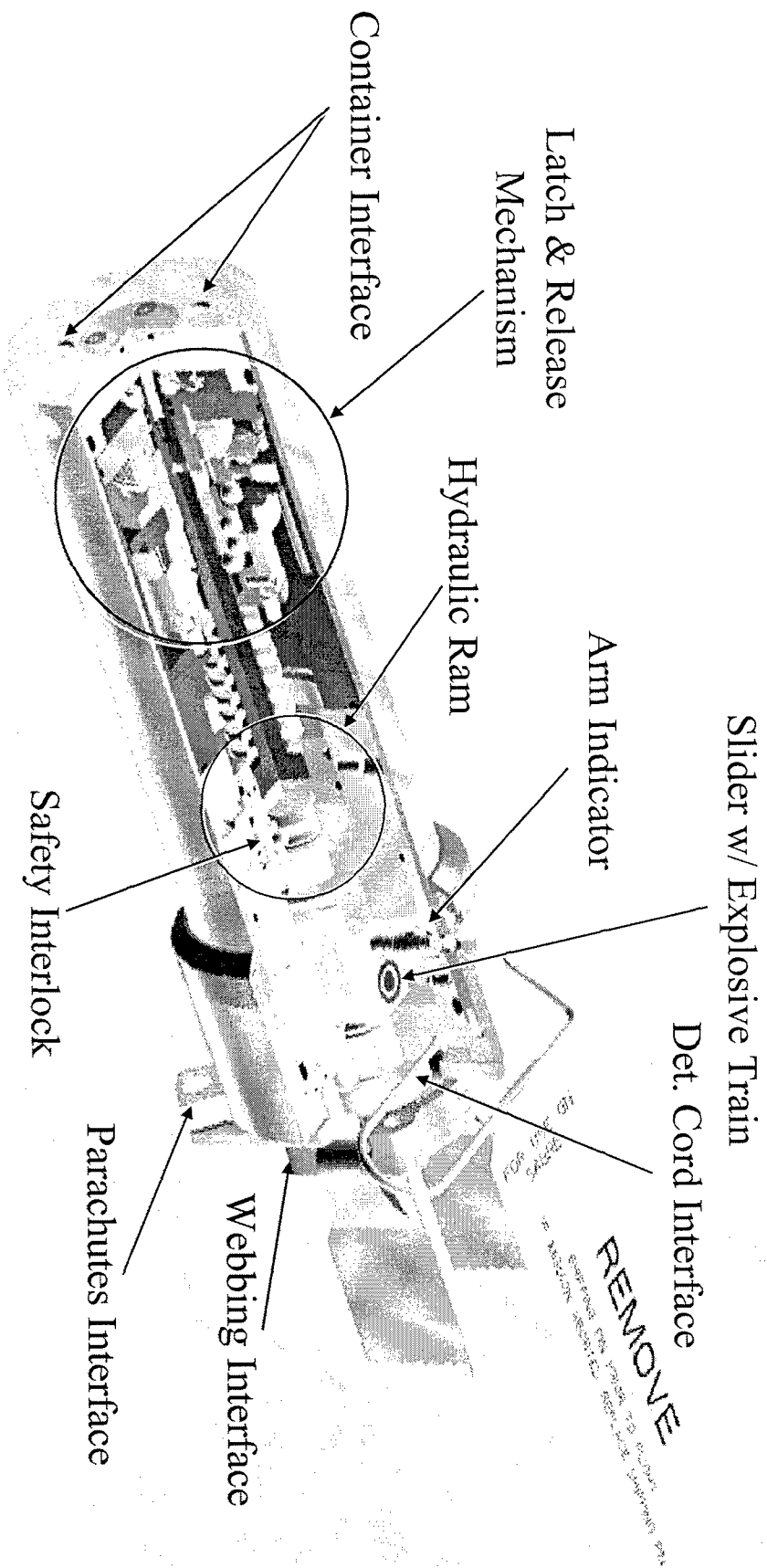

Fuze After Launch

- Tensile pin draws back ram shaft
- 8-second timer started

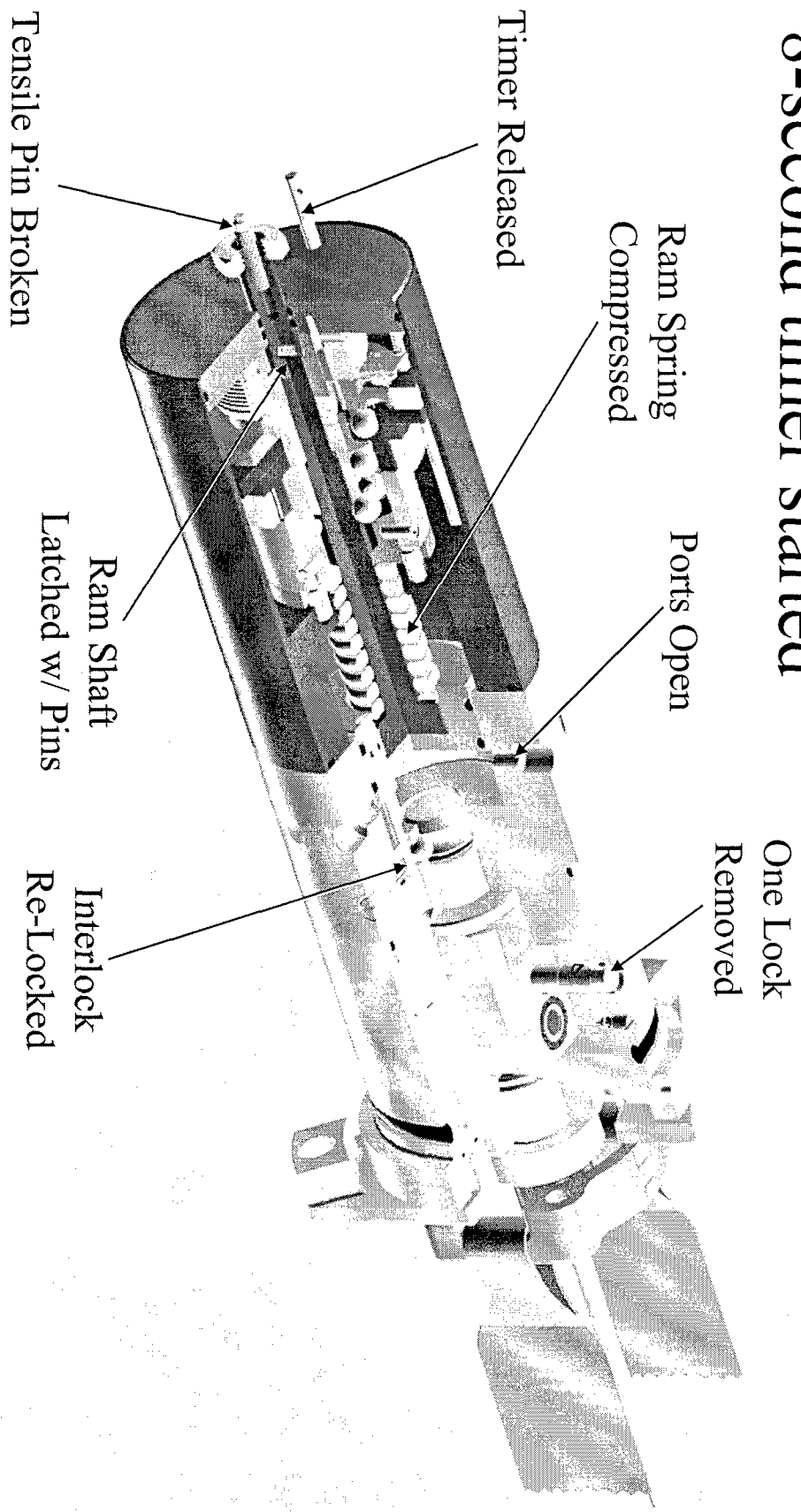



Fuze Armed

- Hydraulic chamber discriminates water from air

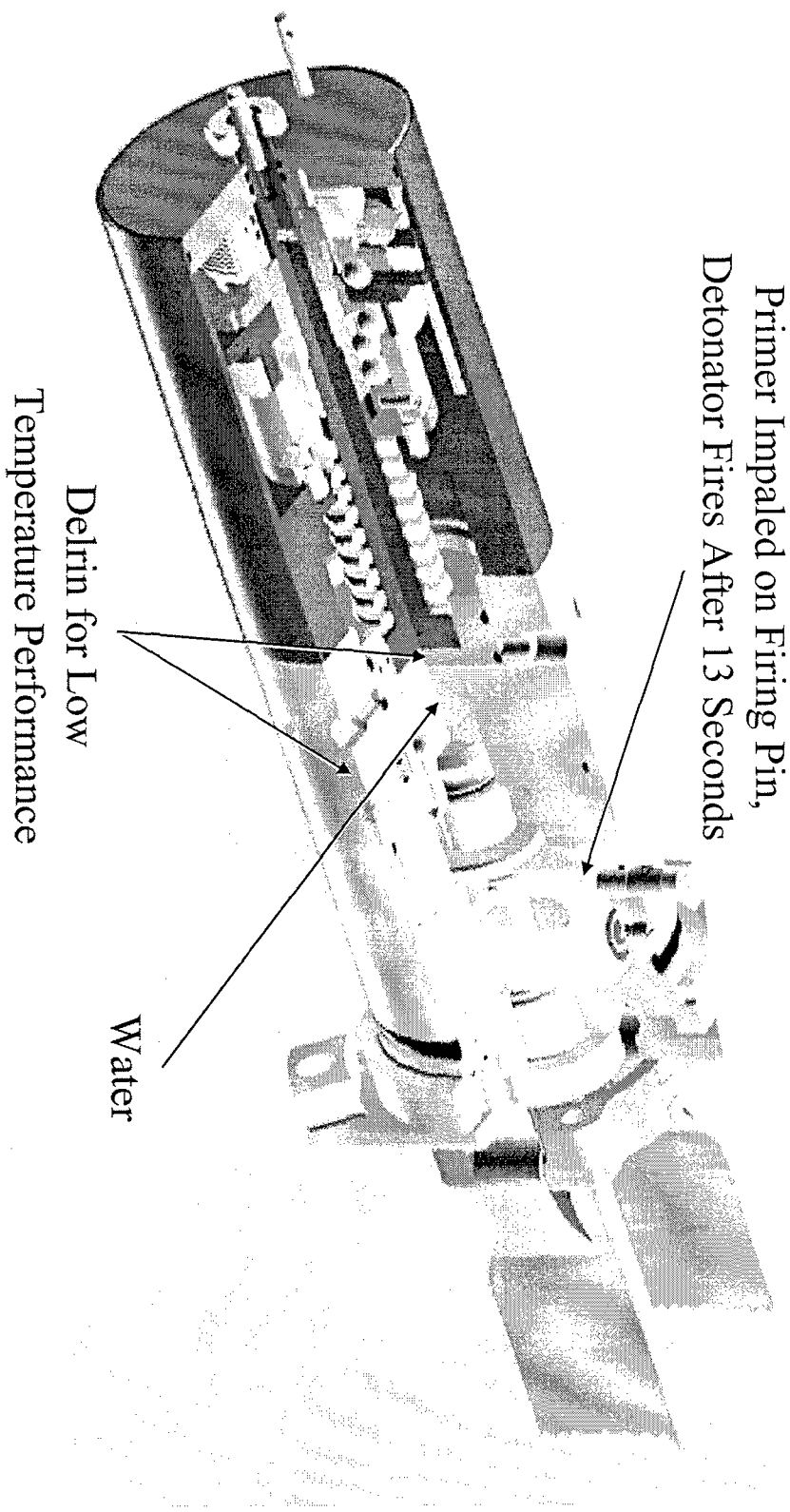

Latch Mechanism

- Used escapement from original fuze
- 2000:1 latch force ratio

Sees .5 in-lb torque from latch

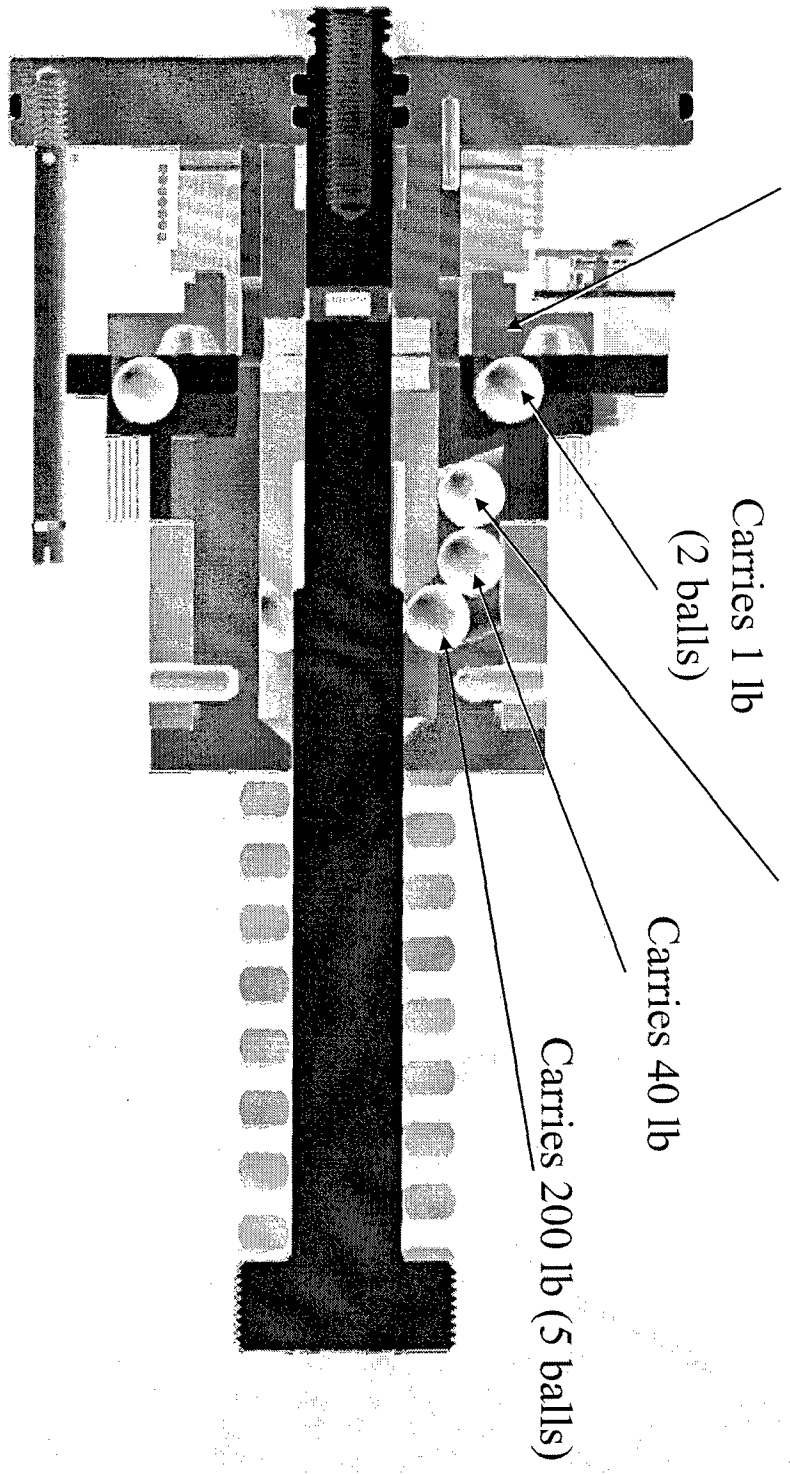

Cotton Pellet Sterilization

- Prevents function within 2 minutes
- Re-safes within 10 minutes

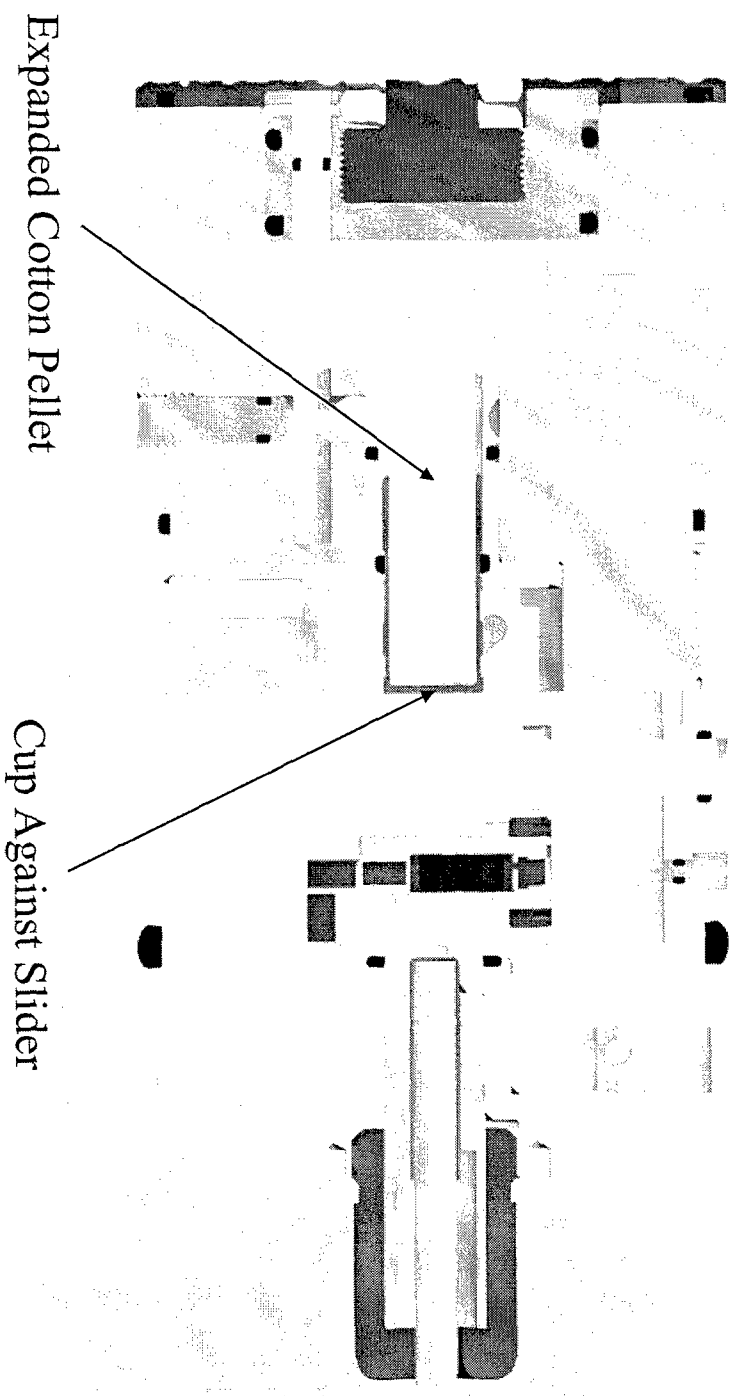

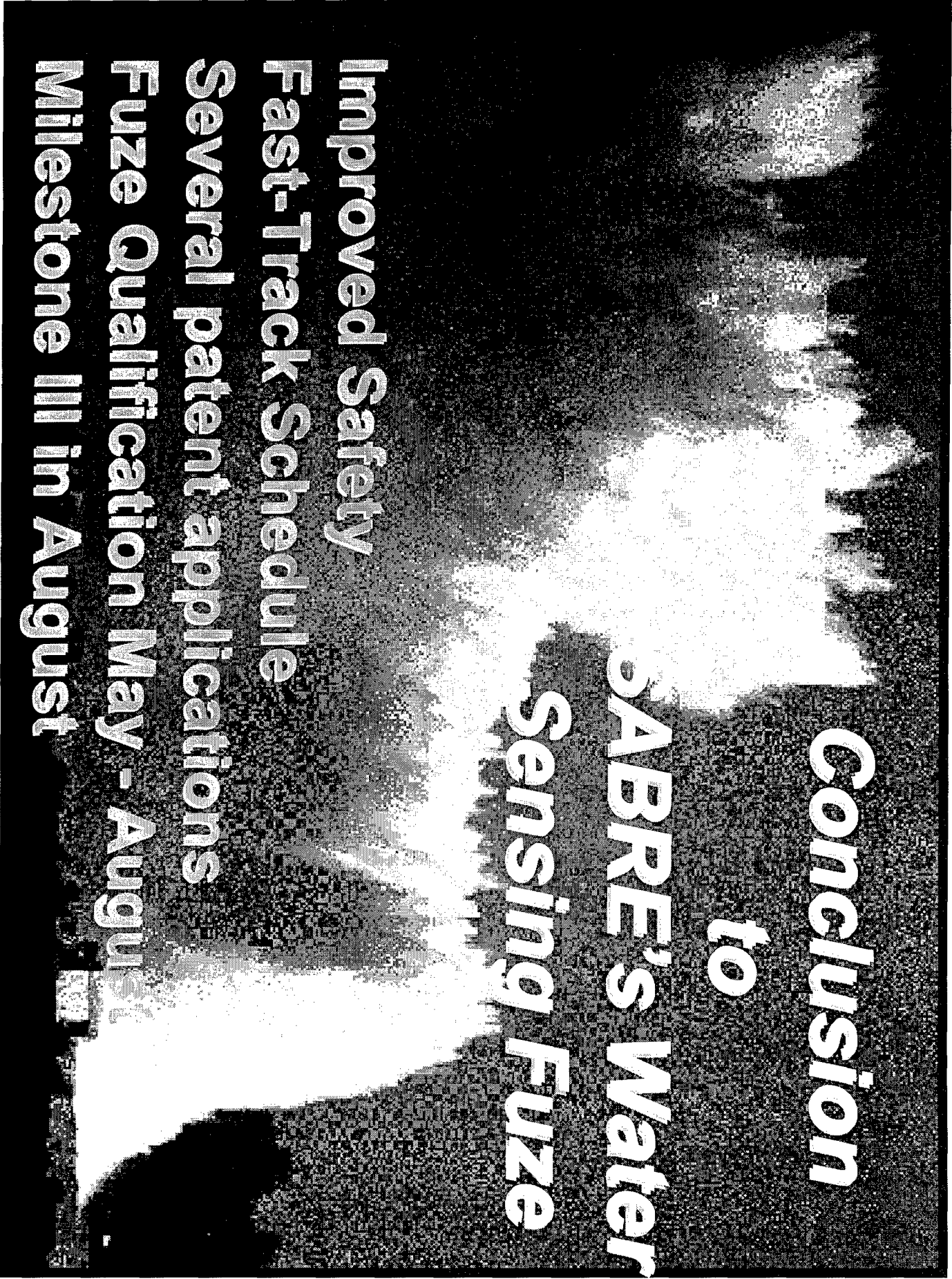

**Conclusion
to**

**SABRE's Water
Sensing Fuze**

Improved Safety

Fast-Track Schedule

Several patent applications

Fuze Qualification May - August

Milestone III in August

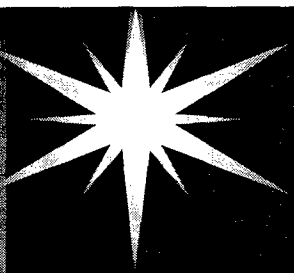

43rd Annual NDIA Fuze Conference

8 April 1999

Miniature Electronic
Safing and Arming Device

Victor C. Rimkus

Sandia National Laboratories
Advanced Military Systems Department
Albuquerque, New Mexico 87185-0860



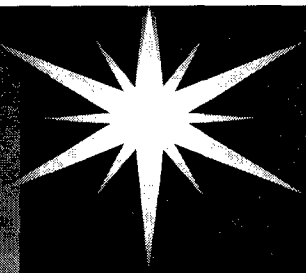

Development Team & Contributors

Victor C. Rinkus

Lead Design Engineer

Lars Wells

Kwong Chu

Robert Bickes

Steve Lebien

Gordon Scott

Steve Harris

Darrell Kirby

Roger Edwards

Mark Grohman

David Faucett

Robert Brooks

Eddie Hoover

Roger Roberts

William Tarbell

Tom Hitchcock

Anthony Mittas

William Brigham

DOD Labs



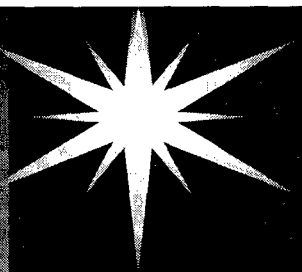

The Challenge

- ▶ Develop a miniature, low cost, all electronic safing and arming device.
- ▶ Provide direction for future technology improvements and developments



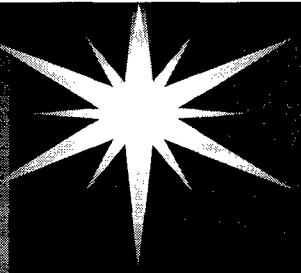

Why an ESAD?

- ▶ No primary explosives
- ▶ No moving parts
- ▶ Long stockpile storage life
- ▶ Increased testability
- ▶ Adaptable to operating in harsh environments

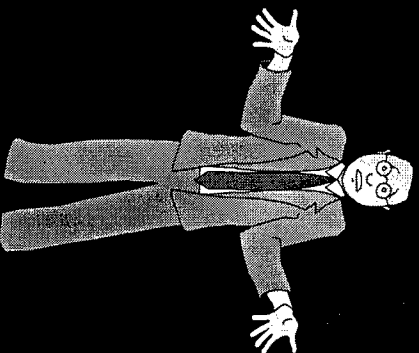

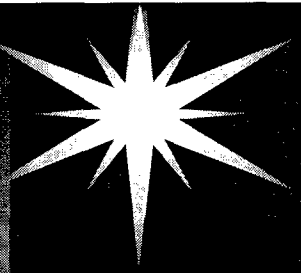

Why an ESAD (Cont.)

Additional intelligence can be incorporated into the design which can include target detection, fuzing logic, and mission specific programmability



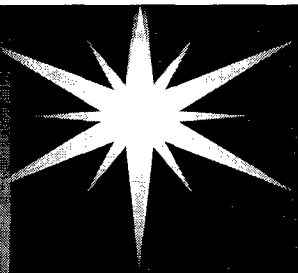

DEFINING THE GOALS

* Initial design goals were based on artillery fuze applications

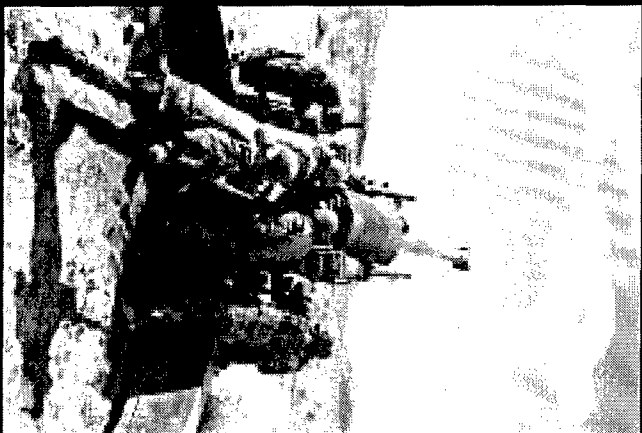

* Future design goals will include mortar, and tank fuze applications

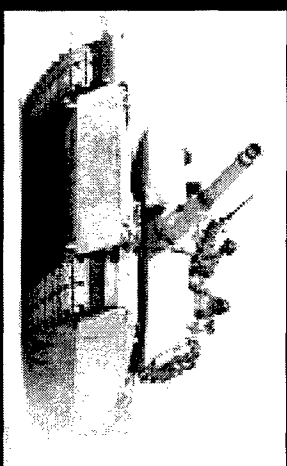
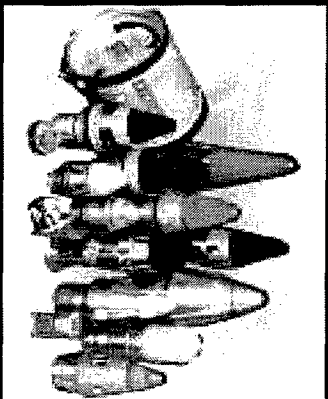

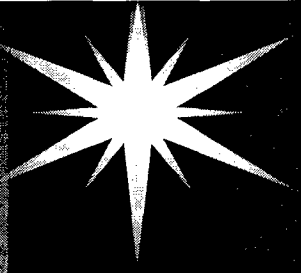

SYSTEM DESIGN GOALS

- * Minimize Volume
- * Minimize Cost
- * Address Manufacturability
- * Define Technology Improvements Needed
- * Define New Technologies Needed



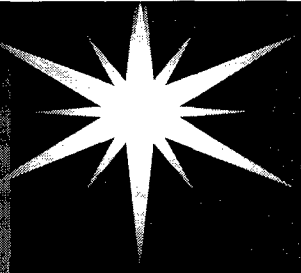

ENABLING TECHNOLOGIES

- ▶ Low energy detonators
- ▶ Solid state high voltage switch
- ▶ High voltage ceramic capacitors
- ▶ Miniaturization of electronic components with increased functionality (pocket electronics)



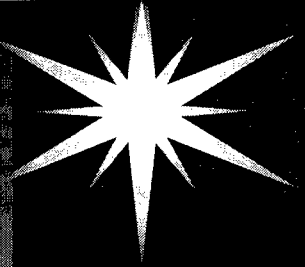

VOLUME GOALS

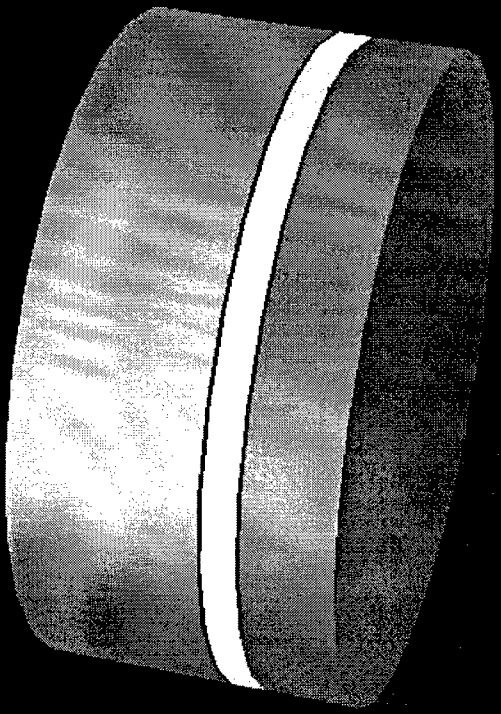

- * FY96 - 3.77 in³
 - ▶ Original goal
- * FY97 - 1.25 in³
 - ▶ Achieved in hardware
- * FY98 - 0.85 in³
 - ▶ Achieved Analytically
- * FY99 - 0.75in³
 - ▶ Progressing



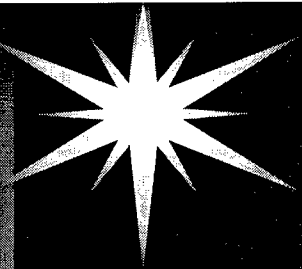

FY97 MINIATURE ESAD

CONTENTS:

- Setback Activated Battery
- Safety Logic
- Acceleration Sensor
- HV Drive Circuitry
- HV Converter
- Solid State HV Switch
- HV Switch Gate Drive
- Detonator
- HNS Pellet

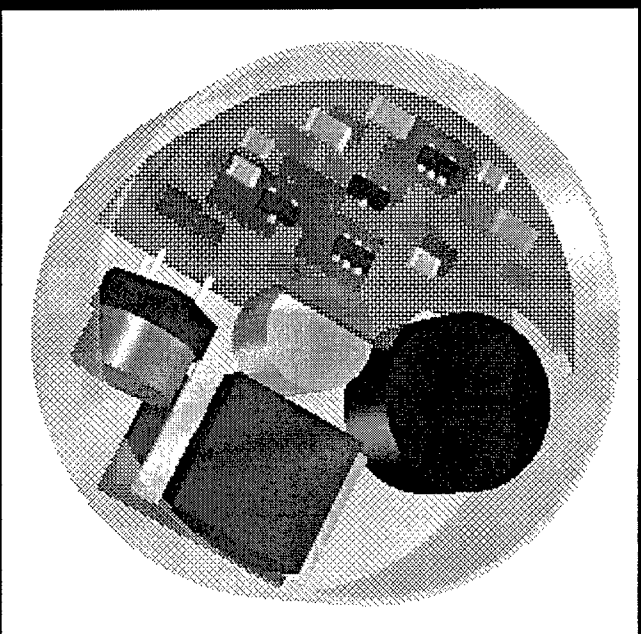

1.5 inch diameter
0.7 inch high

1.25 Cubic Inches



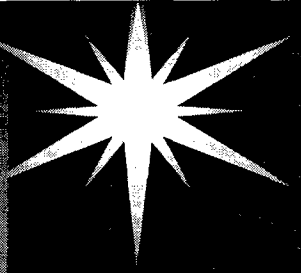

FY97 ESAD (TOP)

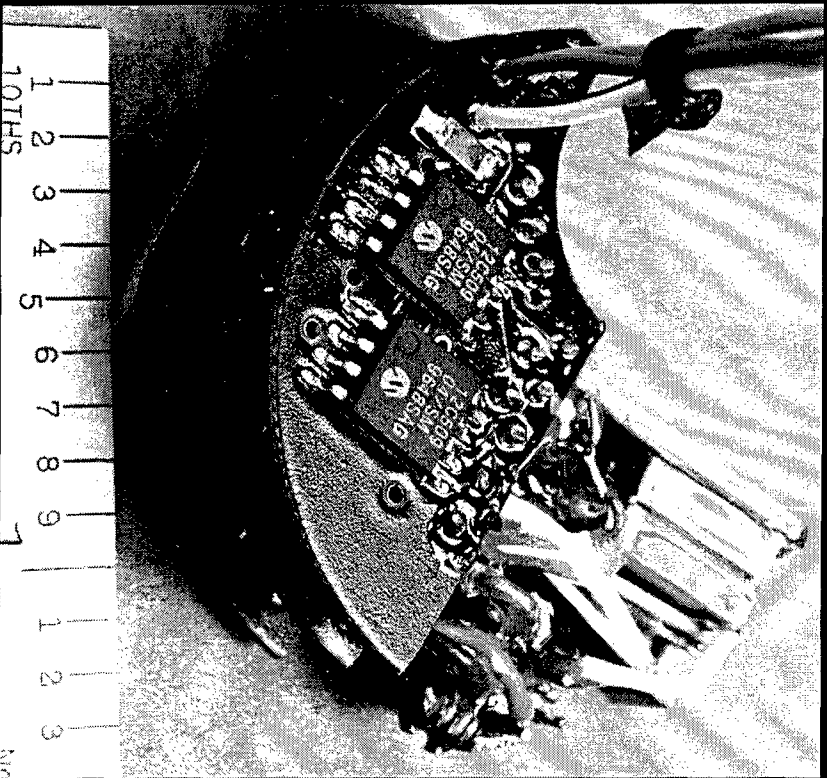

The FY97 miniaturized design is functional and successfully fires Standard Navy Chip Detonators with HNS IV pellets



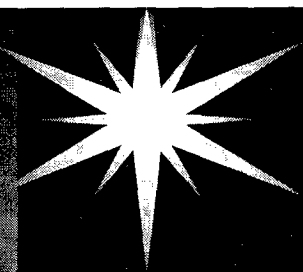

FY97 ESAD (SIDE)

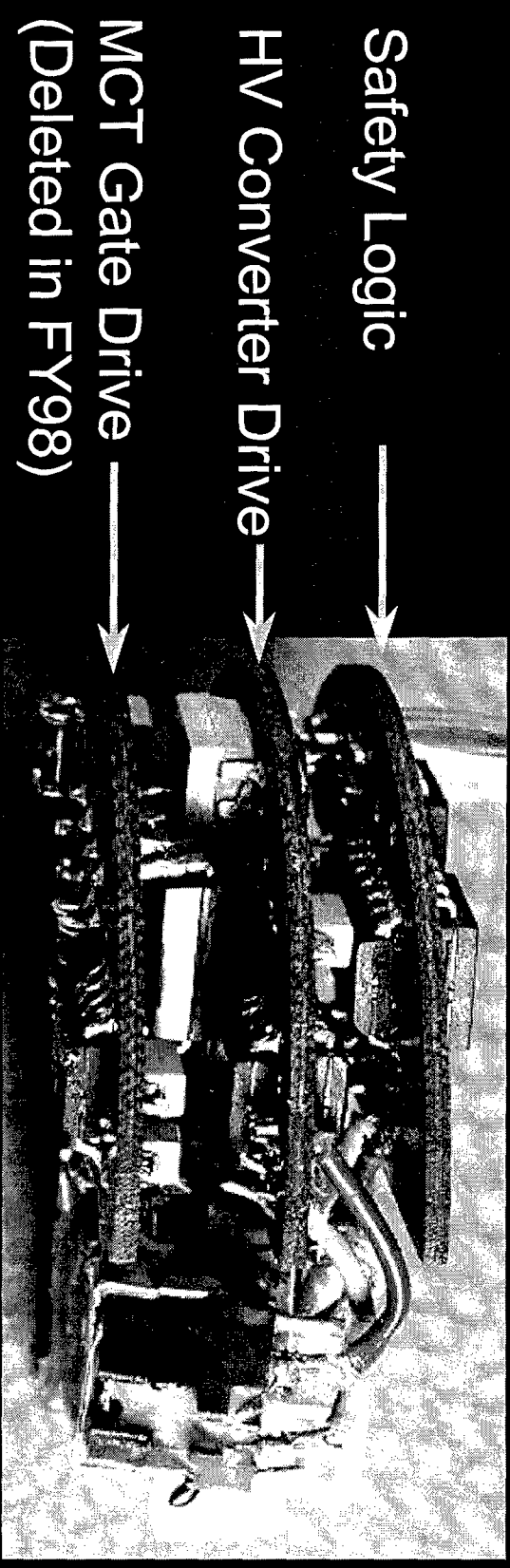

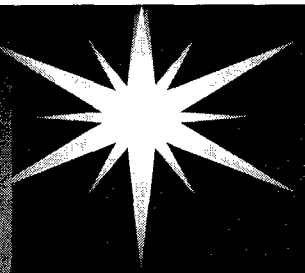

FY97 ESAD (BOTTOM)

HV MCT Switch

2 HV Capacitors

HV Bleed Resistors

Flyback Transformer

HV Diode

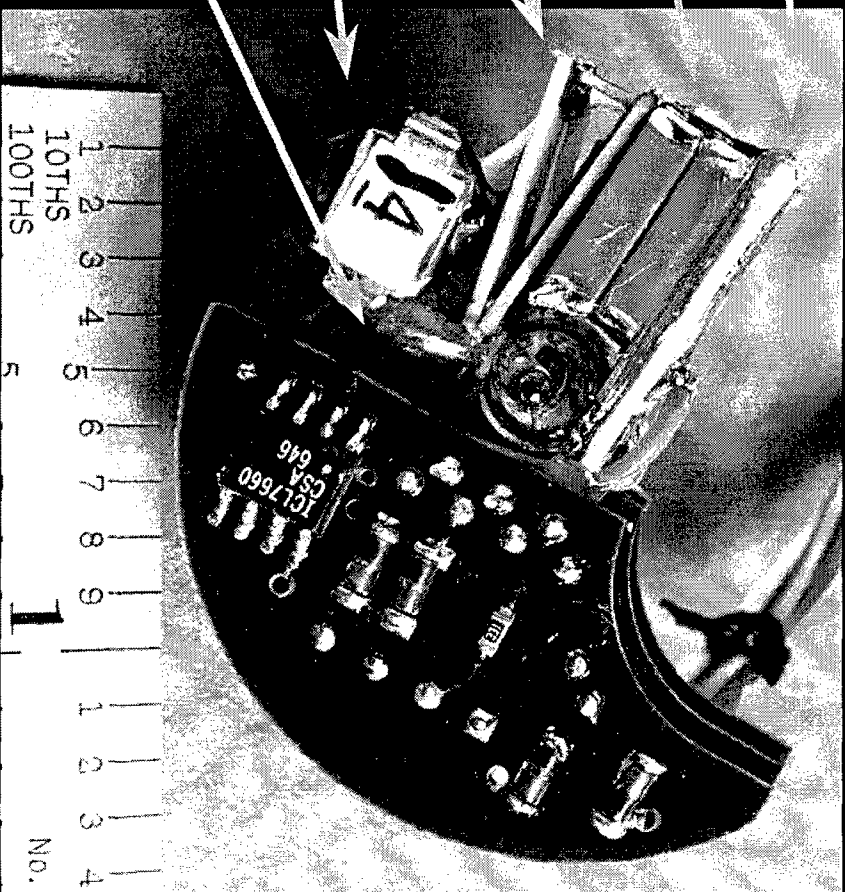

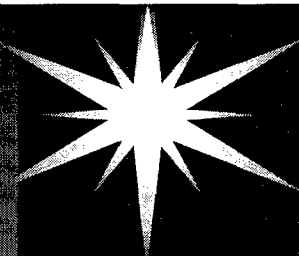

MATERIAL COST GOALS (1k Units)

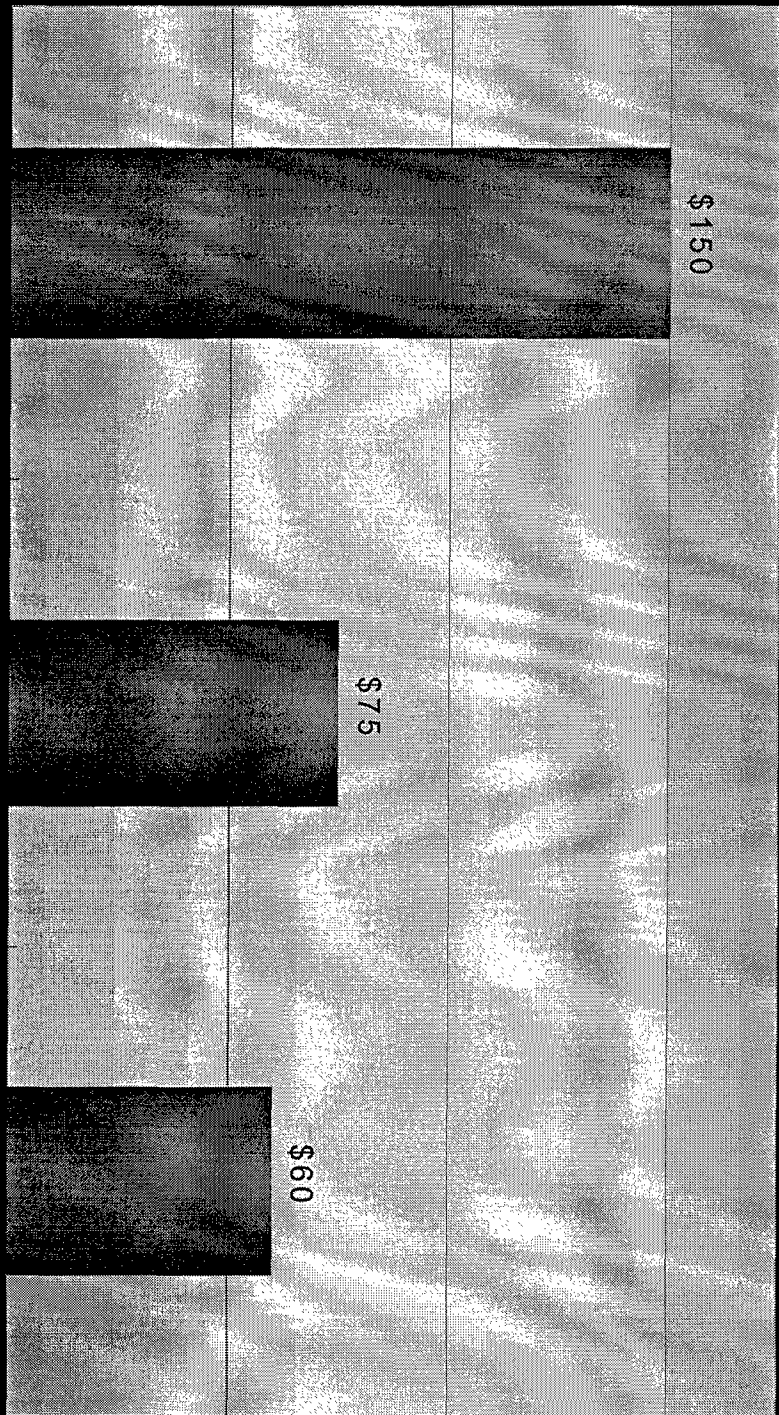

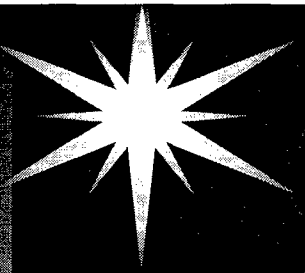

COMPONENT COST BREAKDOWN

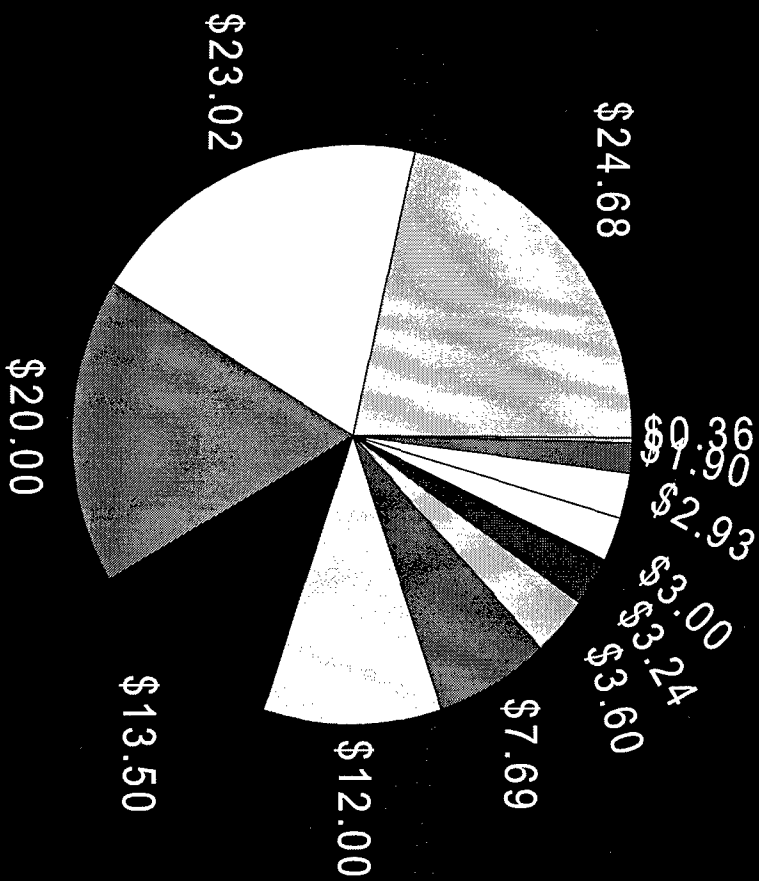

Total Component Cost = \$115.09

- LV Res
- LV Caps
- FETs
- HV Diode
- PCB's
- HV Caps
- LV Logic
- MCT
- XFMR
- Det/HNS
- HV Res
- Accel



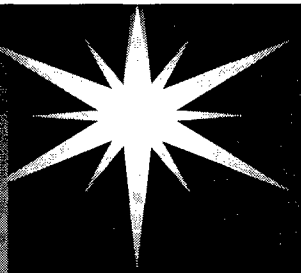

COMPONENT COST SUMMARY

▶ LV Parts	\$14.50	13%
▶ Accelerometer	\$24.68	21%
▶ DET & HNS	\$20.00	17%
▶ <u>HV Parts</u>	<u>\$56.74</u>	<u>49%</u>
▶ Total	\$115.92	100%

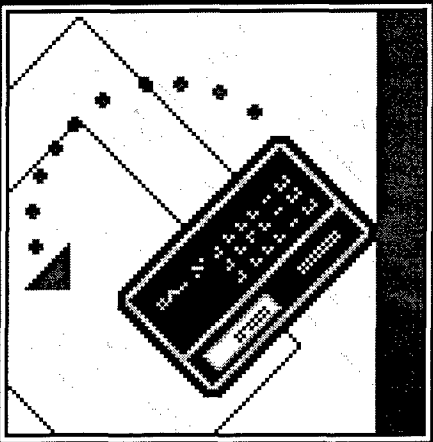

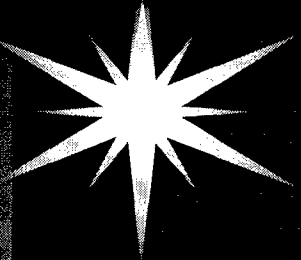

CURRENT TECHNOLOGY IMPROVEMENTS

* HV MCT Switch

- ▶ Improvements in switch gate design
- ▶ Simplifies the required gate drive circuitry
- ▶ Improvements in packaging to better match ESAD applications
- ✓ Two device packages will be available
 - ✓ Commercial TO-218 Package
 - ✓ Harris Thin Pack (half size for size 6 die)



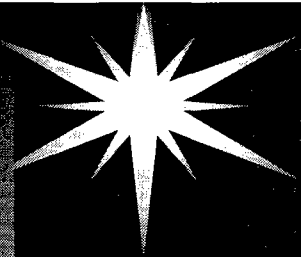

CURRENT TECHNOLOGY IMPROVEMENTS

- * High Voltage Capacitor
 - ▶ Improvements in component internal design
 - ▶ Improved production yield
 - ▶ Increased component reliability
- ▶ Flyback Transformer
 - ▶ Improvements in component design and production techniques
 - ▶ Design modified and production techniques improved



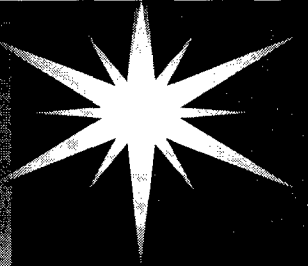

FUTURE GOALS

- ▶ Implement a design using the current technology improvements
- ▶ Incorporate manufacturability improvements
- ▶ Define requirements for mortar and tank fuze applications



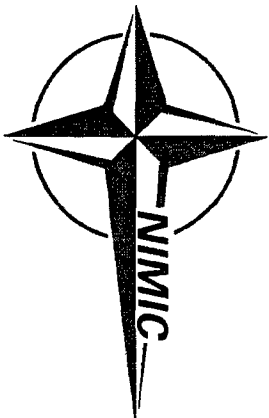

THAMES 3.0

The Window to

Threat Hazard Assessment

Presented by:

Mr. Jason de W. Fitzgerald-Smith
and

Mr. Gerrit Mannessen
NATO Insensitive Munitions Information Centre
NATO HQ, Brussels.

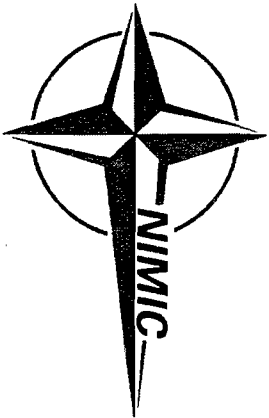

Aim of THAMES 3.0

- The aim of THAMES is to identify Threats and Hazards to any conventional weapon system used throughout its life-cycle.
- As a Decision Support System, it enables those concerned with the operational planning, procurement and development of munitions to conduct design and environmental assessments and assign test procedures for safety and I/M assessments.

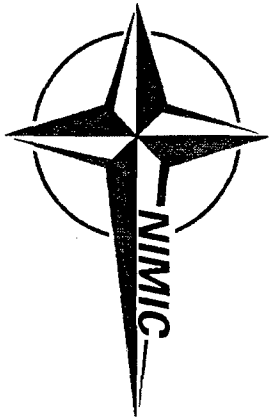

Output of THAMES

THAMES 3.0 provides:

- Design and Safety Requirements
- Assessment of the Design
- Tests to be Performed

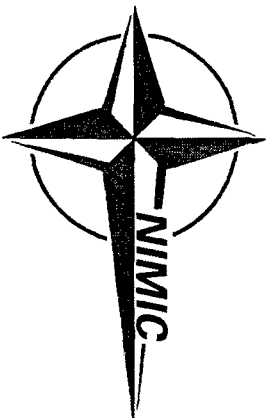

Foreseen Applications of THAMES 3.X

- The main purpose of THAMES 3.x is to facilitate the assessment of threats to munitions in each applicable situation. It will assign a programme of tests that should be used to demonstrate the behaviour of a munition when exposed to defined threats
- For each possible situation during the munitions life-cycle, THAMES 3.x will provide the facility to add information about:
 - the probability of any particular threat
 - the consequences of the munition response on the surroundings
 - the acceptable munitions response

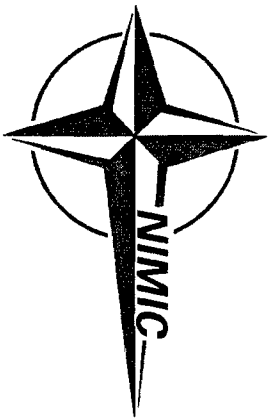

Foreseen Functionalities of THAMES 3.X

- Define situations within a munitions life-cycle and within each situation the applicable threats
- Indicate consequences of threats to the surroundings
- Indicate probabilities of threats within each situation
- Indicate the acceptable response of the munition to threats
- Enable visibility and identification of the reasoning process
- Present the application of documents used within THAMES
- Ability to narrow down the number of applicable documents
- Enable the presetting of threats applicable to certain situations

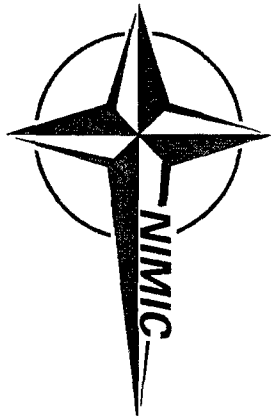

Status of THAMES 3.0 Development

- a feasibility study highlighted two main functions:
 - Threat Hazard Assessment of munitions
 - THA Document Information System
- the development resulted in :
 - a THAMES Beta II version released in March '99
 - an expanded THA approach
 - an extended prototype of the Document Information System

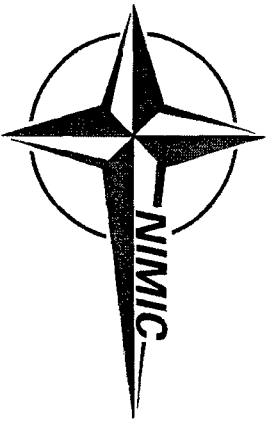

Development Life-Cycle of THAMES

- THAMES 3.0 Beta II released March 1999, for testing purposes by key THAMES users
- THAMES 3.0 in Oct 1999, with data im/export functions, reporting facilities, and improved usability and performance
- THAMES 3.1 date tbd, advanced pre-selections, inclusion of a hazard assessment module and inclusion of National status in relation to NATO documents
- THAMES 3.2 date tbd, enhanced Threat and Hazard facilities, final user-interface, enhanced reporting facilities, maintenance facilities, on-line help, user-guide and system documentation

This will strongly depend on the available resources within NIMIC and the support of Nations with additional programmer attachments

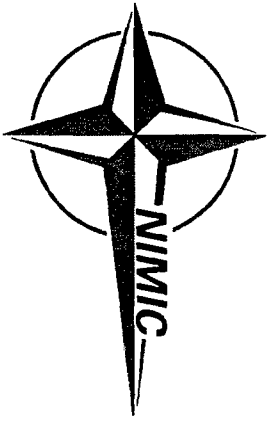

THAMES 3.0 Munition Categories

➤ THAMES 3.x will support the following list of munition categories:

1. Artillery/Naval Guns and Ammunition
2. Mortars and Mortal Ammunition
3. Tank Guns and Ammunition
4. Cannon (12.7 - 40 mm) Guns and Ammunition
5. Grenades
6. Small Arms and Small Arms Ammunition
7. Land Mines
8. Demolition/EOD Munitions
9. Guided Weapons and Rockets, incl. Bombs, Dispensers, LAW
10. Sea Mines and Depth Charges
11. Torpedoes
12. Pyrotechnics

THAMES Threat Hazard Assessment System



Add Assessment

Export Assessment

Add ? Situation Levels



View Inspector

About

Exit

Delete Assessment

Import Assessment

View User Situations & Threats

Current Assessment: NDIA/Fuze

Add Munition | Delete Item | Generate Report | Expand | Collapse

- Art/Nav Guns & Ammo
 - Tampa 99
- Logistical Phase
 - Manufacturer to Peacetime Storage
 - Transport to Peacetime Storage
 - Road/Rail
 - IM Threats:
 - Induced Environmental Threats
 - Natural Threats
 - Non-sequential Safety Threats
 - Peacetime Storage
 - Igloo/Explosive Store House
 - Logistic Deployment to Op Area
 - Transport to Op Area
 - Naval Logistic Ship
 - IM Threats:
 - Induced Environmental Threats
 - Natural Threats
 - Non-sequential Safety Threats
 - Tactical Phase
 - Tactical Deployment and Use
 - Sea
 - Surface Ship
 - Disposal Phase
 - Disposal
 - Transport
 - Road/Rail

Past Assessments | Threats | Munition Categories | Documentation

- IM Threats
 - Bullet Impact (BI)
 - Fast Heating (FH)
 - Fragment Impact (FI)
 - Reaction of an Adjacent Munition (RAM)
 - Shaped Charge Jet Impact (SCJI)
 - Shaped Charge Spall Impact (SCSI)
 - Slow Heating (SH)
 - Induced Environmental Threats:
 - Acoustic Noise, Combined with Temperature and Vibration
 - Acoustic Noise
 - Bending
 - Constant Acceleration
 - Decompression
 - Drop (logistical)
 - Drop (tactical)
 - Electromagnetic Radiation Hazard
 - Electrostatic Discharge
 - Gunfire Shock
 - Jolt (fuze)
 - Jumble (fuze)
 - Laser Hazard
 - Loose Cargo Bounce
 - Lifting
 - Racking
 - Rail Impact
 - Rough Handling, Parachute Drop, Bump, Shock, Drop, Top Shock
 - Stacking

Assessment Component Inspector

Description | Options |

Assessment | Munition Category | Munition | Situation | Threat | Test |



Test Code JOLT

Entered by NIMIC

Test Title

Jolt (Fuze) Test

Description of the test as applied to the threat

Remarks about the test as applied to the threat

Test Documentation

Nation: US

Authority: DOD

Originator: Army

Document: MIL-STD 331

Edition: B

Draft:

Status: CANCELLED

Date: 1/03/97

FUZE AND FUZE COMPONENTS ENVIRONMENTAL AND PERFORMANCE TESTS FOR

Section: Appendix A1

TEST A1 - JOLT - APPENDIX A MECHANICAL SHOCK TESTS

Description

1. PURPOSE

This is a laboratory safety test simulating ground transportation-conditions. The fuze must withstand a series of impacts applied in a controlled direction and amplitude.

2. DESCRIPTION

2.1 General

Fuzes are subjected to 1750 impacts in three orientations: major axis horizontal and major axis vertical both nose up and down.

2.1.1 Jolt machine method

NIMIC/National Note

Record: XX

Accept

Undo

Help

Stay On Top

View Main Form

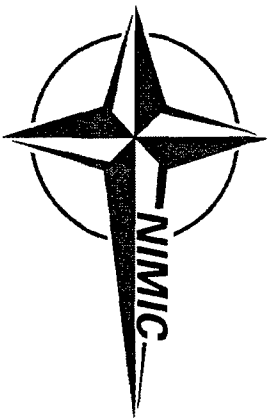

THAMES 3.X Document Information System

- THAMES 3.x will incorporate all relevant NATO documents associated with munition safety and suitability for service as well as Insensitive Munition (IM) requirements, and allows the capability to include relevant national documents.
- the system will include:
 - design, testing, environmental, S³ and policy type documents
 - status of documents (promulgated, draft, etc)
 - abstract and objectives of documents
 - document information (host organisation, date, etc.)
 - relations between document sections and munitions, threats and tests
 - relations between documents (implements, references, relates)

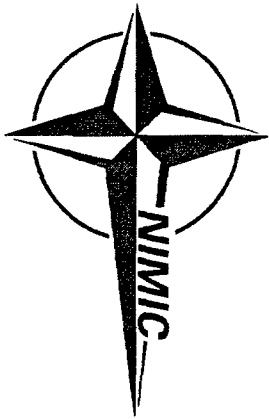

Conclusions

- the feasibility study and analysis are completed, resulting in:
 - an expanded functionality
 - a Threat Hazard Assessment Document Information System
- a THAMES 3.0 Beta II prototype has been developed:
 - is available for testing purposes by key users
 - for the THA Document Information System
- the THAMES 3.0 is a subset of the foreseen full application and functionalities
- an operational THAMES 3.0 version will be available later this year to Government and Industrial organizations of NIMIC member Nations

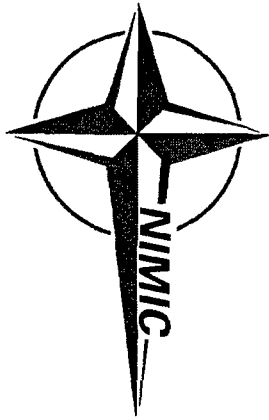

Presented by:

Jason Fitzgerald-Smith MSC

Tel.: 32 - (0)2 - 707 - 5426
E-Mail: j.fitzgerald@hq.nato.int

Gerrit Mannessen MSC

Tel.: 32 - (0)2 - 707 - 5645
E-Mail: g.mannessen@hq.nato.int

NATO Insensitive Munitions Information Centre

Address: NIMIC / NATO Headquarters
Autoroute Zaventem
B-1110 Brussels
Belgium
Fax.: 32 - (0)2 - 707 - 5363
WWW: <http://hq.nato.int/related/nimic>

Design and Qualification Results for the Firing Module for the Common Module ESAF (C-ESAF)

IO

Optoelectronics

T. Andrew Demana
Dan Knick
Barry Neyer
Bill Newman
John Adams
Jim Edwards
Allen Seals
et al.

M

ELECTRONICS & MISSILES

S

Jim Kane
Hemant Patel
Jim Dowdle
Gary Schreffler
John Savage
Frank Gili
et al.

Many thanks to those who have labored 'behind the scenes' to make the C-ESAF happen and those in the various project offices who have offered suggestions and sat through many telecons!

LOCKHEED MARTIN

IO 1

Outline

- Design / Concept Overview
 - Requirements
 - Electronics Module Overview
- FM Features
 - Detonator
 - Electrical
 - Packaging / Attachment
- Design Verification Tests & Lessons Learned
- Qualification
 - Detonator
 - FM
- Production

LOCKHEED MARTIN

ÌÒ 2

The C-ESAF Was Developed in Conjunction with Lockheed Martin

- Lockheed Martin E & M designed the Electronics Module (EM).
 - EM to be manufactured in LM's Ocala facility.
- EG&G designed the Firing Module (FM).
 - FM to be manufactured primarily in EG&G's Covina, CA and Miamisburg, OH Facilities.

LOCKHEED MARTIN

ÌÒ 3

The C-ESAF Meets the Challenges

- **Low Cost** - use of commercial technology
- **Reliable** - $P_{\text{fire}} > 0.995$
- **Safe** - $P_{\text{arm}} < 10^{-6}$
- **Flexible** - functions over multiple programs -
 - Processor based system
 - Packaged to fit
- **Functions after precursor WH detonation**
- **Functions in ARGON environment**

The Electronics Module Drives the Firing Module

appropriate conditions are met the EM:

- Initiates Launch Motor Squib (Javelin)
- Initiates Flight Motor Squib (Javelin)
- Arms Firing Modules - after safe separation
- Senses Target (Impact / G-switch)
- Triggers Precursor Firing Module
- Triggers Main Firing Module - after tactical delay

LOCKHEED MARTIN

IO 5

The EM is Built in LM's Ocala Facility

- Electronics Module

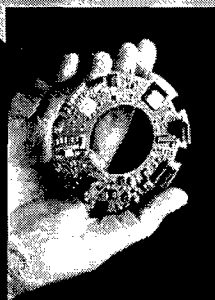
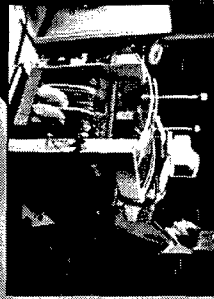
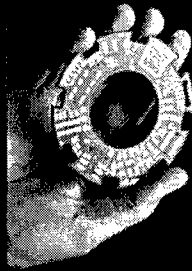

• EM & FMs may be assembled at missile or before

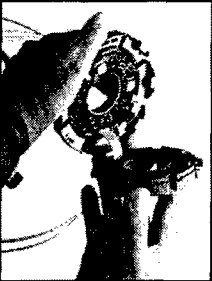
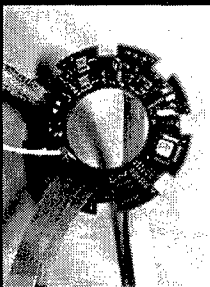
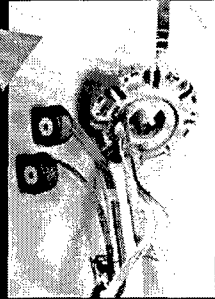

LOCKHEED MARTIN

10 6

EG&G Designed the Firing Module Based on LM's Specification

- Specification SPC10409200-002 combines the requirements of several systems



JAVELIN



HELLFIRE



LANGBOW

BAT - environmental requirements included, packaging changes required to fit.

LOCKHEED MARTIN

ÌÒ 7

The Firing Module Design Was Challenging

- THE FM MUST:
 - Fit in .765" X 1.55" Å space
 - Weigh < 50 g
 - Withstand combined environments
 - Convert charge signal from EM
 - Initiate 6 different warhead configurations

LOCKHEED MARTIN

ÌÒ 8

The Firing Module Meets or Exceeds All Functional Requirements

| REQUIREMENT | ACTUAL |
|--|--|
| All Fire Voltage: 2200 V max
99.999% Reliability, 95% Confidence | Guaranteed Voltage: 2450 V
1600 V All Fire |
| Charging time: < 250 msec | < 120 mSec
Hot, Ambient, Cold |
| Bleed-down to <500 V: <45 sec. | < 36 sec in all temperatures |
| Mass: < 50 g | 46 g |
| Mechanical Mounting for precursor and
main charge in: Javelin, Hellfire/Longbow,
and BAT | Accomplished with molded
adapters
(BAT requires new packaging) |
| Low Temperature: -45 C operational
-46 C non-operational | Tested to -46 operational |
| High Temperature: + 71 C operational &
non-operational | Tested to +71 operational |
| Temperature shock: -46 C to +71 C <5 min | Tested -46 C to + 71 C
successfully |

LOCKHEED MARTIN

IO 9

The Firing Module Meets or Exceeds All Functional Requirements

| REQUIREMENT | ACTUAL |
|---|--|
| Altitude: 0 to 4750 m (operational)
0 to 12,190 m (operational after exposure) | Tested Successfully in qualification |
| Captive Flight Vibration: | Combined Javelin, Hellfire/Longbow & BAT tested successfully |
| Transportation Vibration | Combined Javelin, Hellfire/Longbow & BAT tested successfully |
| Impact Shock:
Precursor → 30k g roll, 10k g pitch & yaw
Main → 10k g all axes
Detonation EMP: → 100 V with ± 250 V safety margin (100 ? sec pulse) | Tested Successfully in DVT and Javelin CQT |
| Argon Exposure: operate before during and after 80% Ar | Tested Successfully in Javelin CQT |

LOCKHEED MARTIN

IO 10

The Firing Module Consists of Two Subassemblies

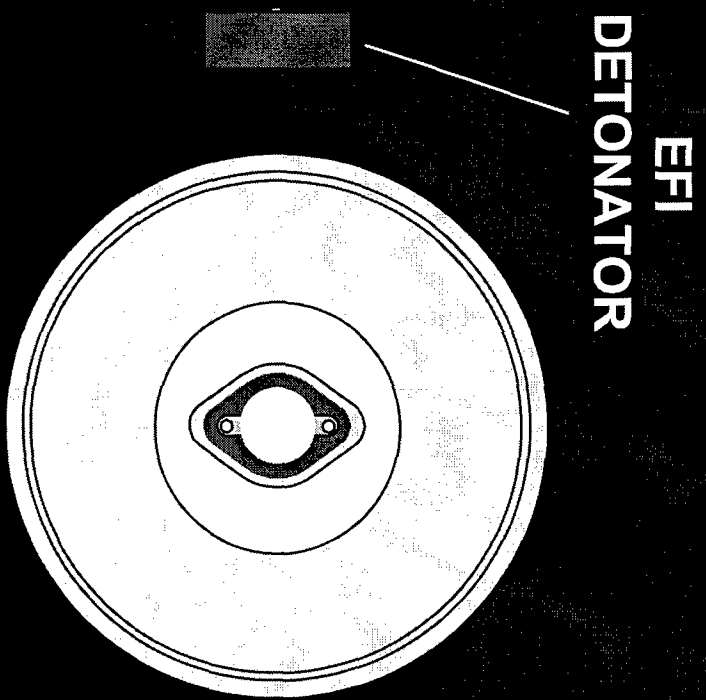
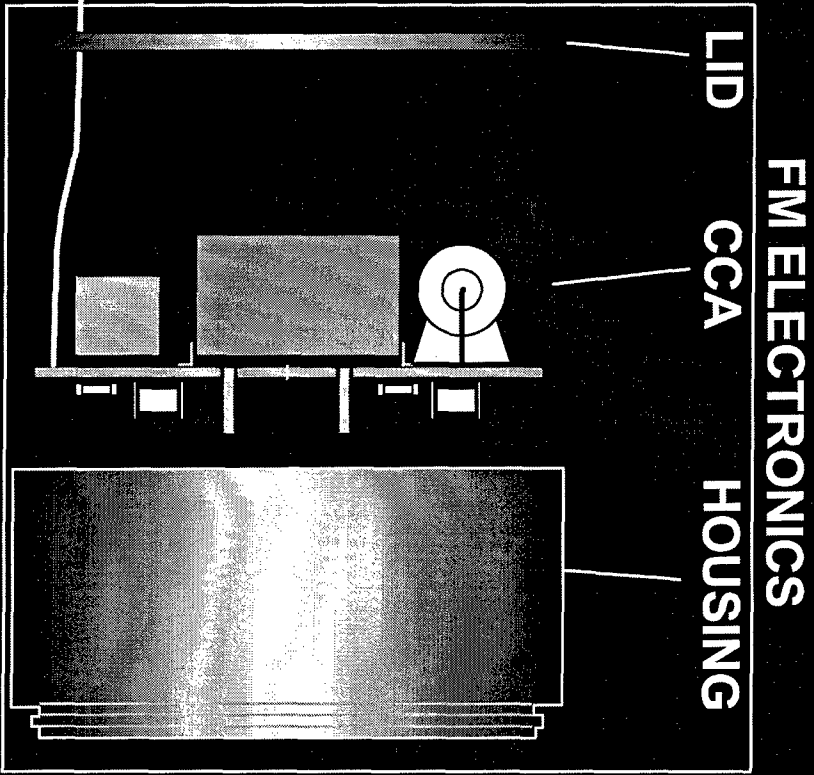

LOCKHEED MARTIN

10 11

The EFI is Insertable & Removable

- EFI can be inserted after FM is fully tested (charged and triggered).
 - EFI can be replaced by inert load (CVR).
- EFI can be removed for EOD.

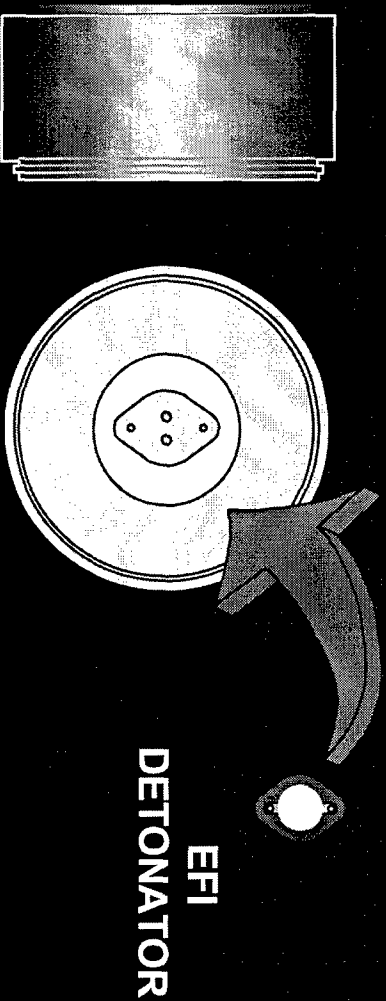

LOCKHEED MARTIN

IQ 12

The Output is Designed to Initiate the PLCs with a Ni Flying Plate

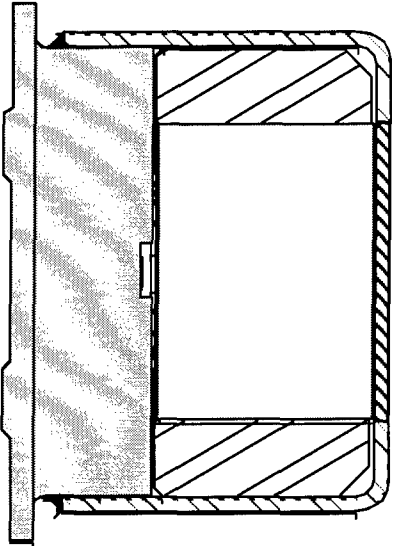
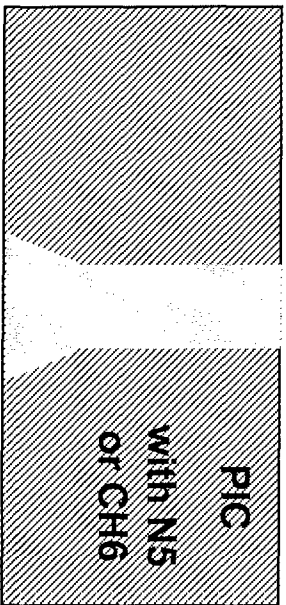

- The Detonator can initiate N5 and CH6 across a variety of gaps.

LOCKHEED MARTIN

IO 13

Firing Module Has an EMI Shield

- FM Housing is plated.
- Cable is shielded.

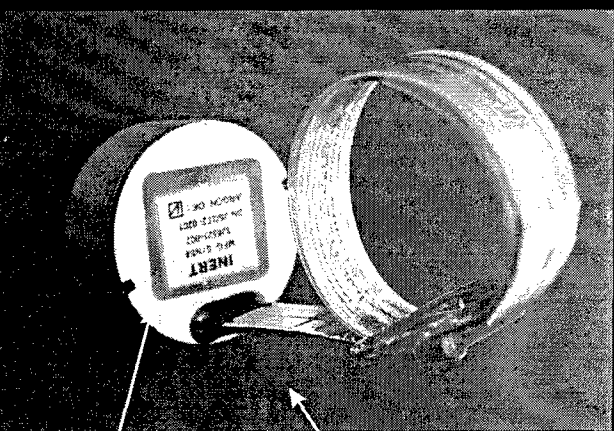

Shielded 5-wire Flat Cable

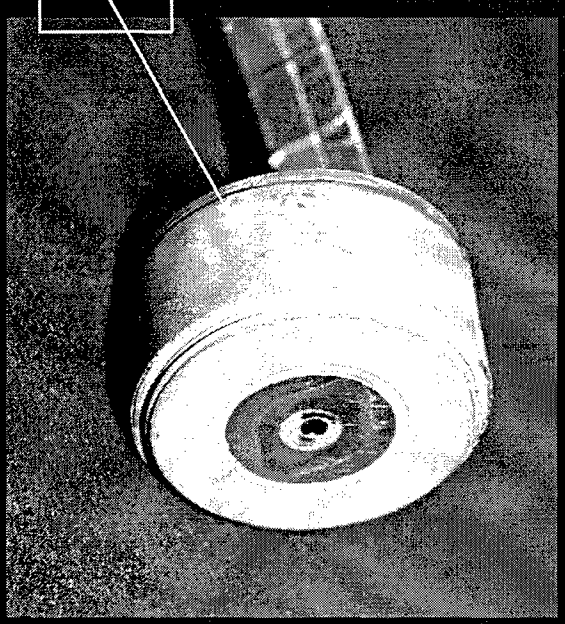

Molded Housing with Conductive Coating

LOCKHEED MARTIN

IO 14

The Charging & Firing Circuit is Designed to:

- **Minimize Charge Time**
- **Optimize Trigger Circuit**
 - Cable length effects trigger pulse quality.
- **Develop Efficient Firing Circuit**
 - Minimize Inductance and Resistance.
- **Meet discharge requirements**
 - Current design < 45 seconds.

LOCKHEED MARTIN

10 15

FM Schematic Features Voltage Converter and Redundant Bleeders

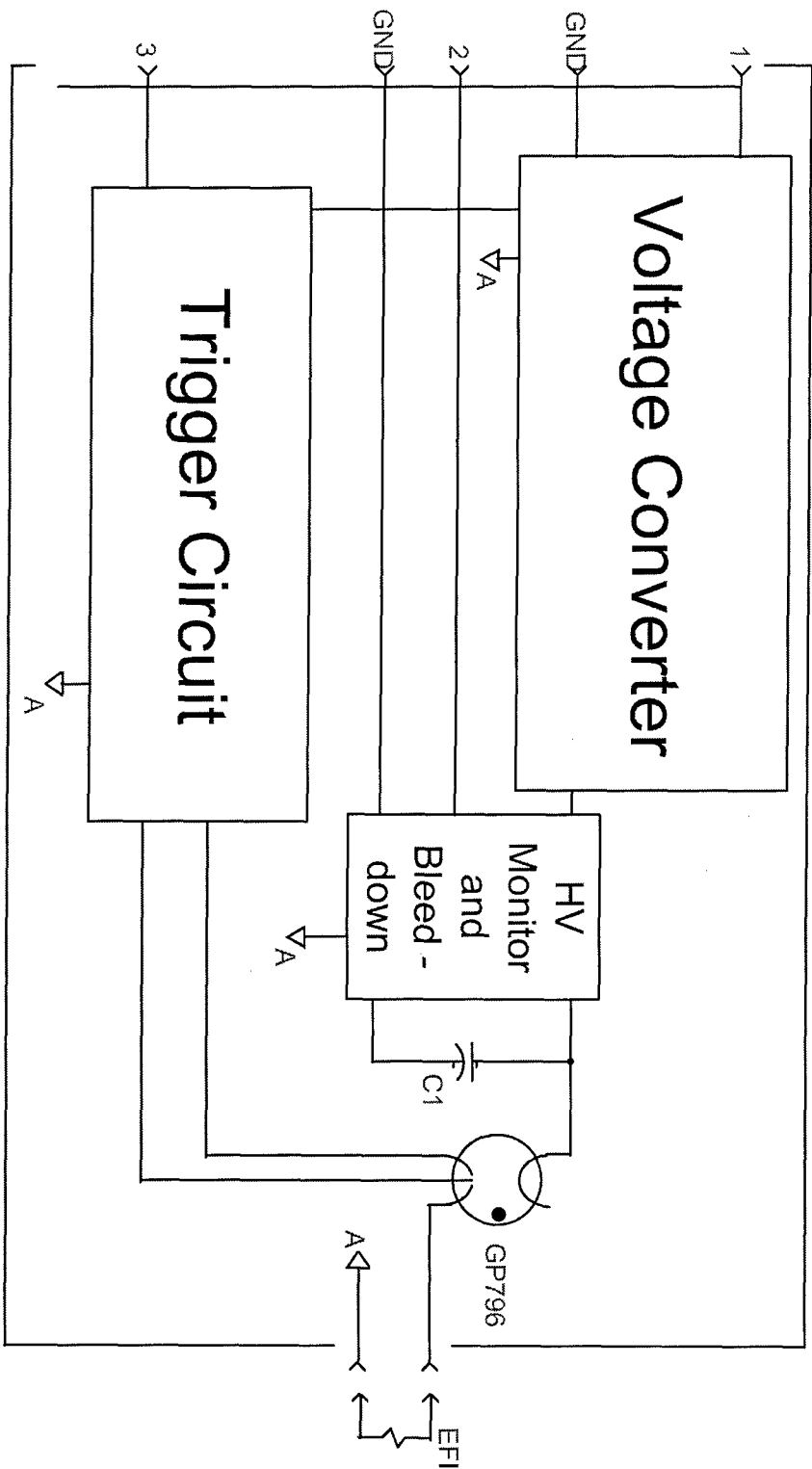

LOCKHEED MARTIN

IO 16

The FM Uses Surface Mount and Plated-Through-Hole Technology

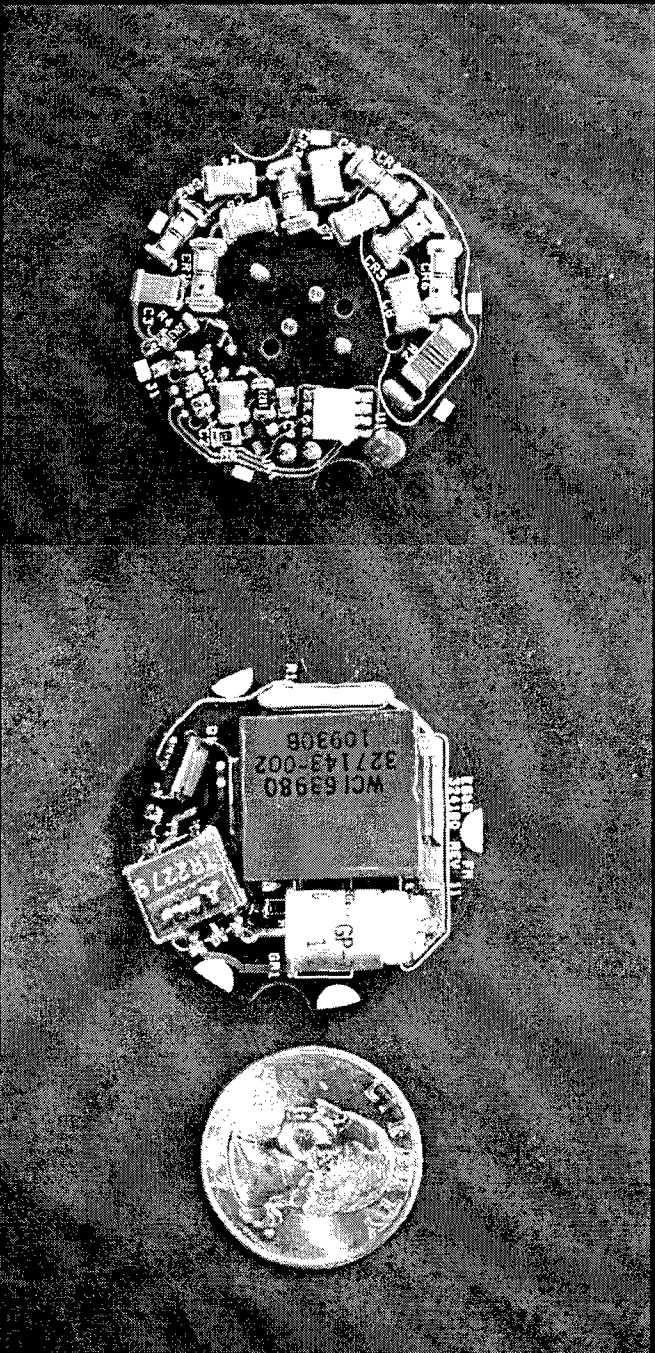

SMT Manual Soldering

LOCKHEED MARTIN

ÌÒ 17

Firing Module is Inherently Safe

- FM and detonator NOT sensitive to ESD.
- Can be initiated ONLY when properly charged.
 - All firing and trigger energy delivered to FM only after “arming cycle” has started.
- Redundant HV bleeder resistors.
- Must dissipate firing energy in less than 30 minutes with no common-mode or common-point failures.
 - Actual discharge will take place in less than 40 seconds.

LOCKHEED MARTIN

10 18

Components Selected to Meet Temperature and Performance Requirements

- **Main Capacitor**
 - WCl, 0.1 μ F, 3kV, Ceramic.
- **Trigger Transformer,**
 - New EG&G design, smaller package.
- **Spark Gap, GP796 (baseline), GP786 (alternate)**
 - New, low cost, semiconductor packaging.
 - Development and qualification life test data indicate life greater than 2000 shots.
 - GP466 family of spark gap
 - » Long history in DoD applications.
 - » Qualified for various S/A devices.
- **Blue Chip? Detonator**
 - Qualified for multiple programs.

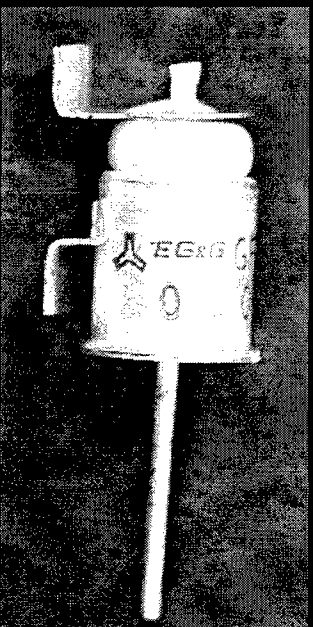

LOCKHEED MARTIN

19

Double and Triple Argon Barriers Are Applied

- Two proven materials employed
 - Conformal coating - Parylene 'C'
 - Polyurethane applied to selected areas before and after Parylene.

LOCKHEED MARTIN



ÌÒ 20

FM Attachment is Universal

- Single - turn thread is compact and sturdy.
 - Threadlock allows removal.
- Adapters provide consistent flyer distance.
- Can be adapted to a variety of warheads.

Javelin and Hellfire/Longbow Adapters have been made.

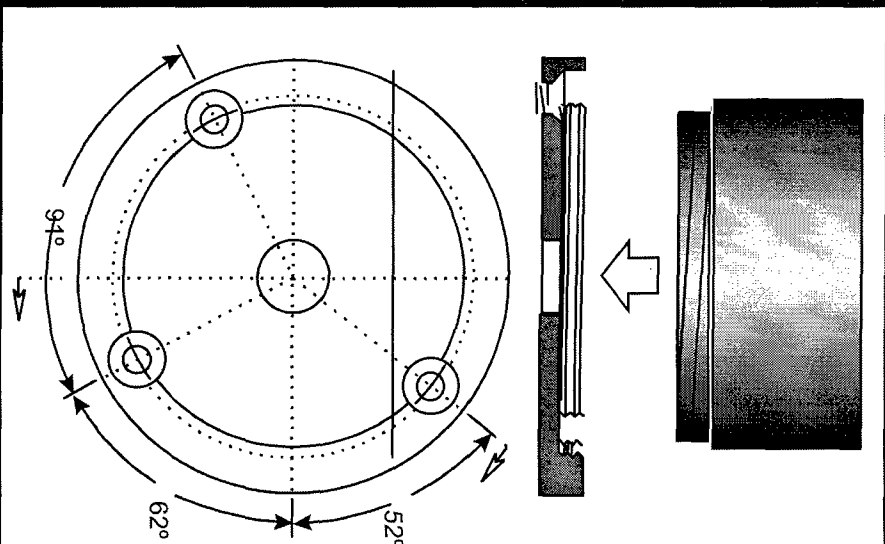

LOCKHEED MARTIN

ÌÒ 21

FM Can Be Adapted to Fit the BAT

- The Precursor FM is mounted on the "side" of the warhead - there is no room for a "hockey-puck."
- The Precursor FM has an EFL cable (without H.E.) which folds around to connect to the PIC.

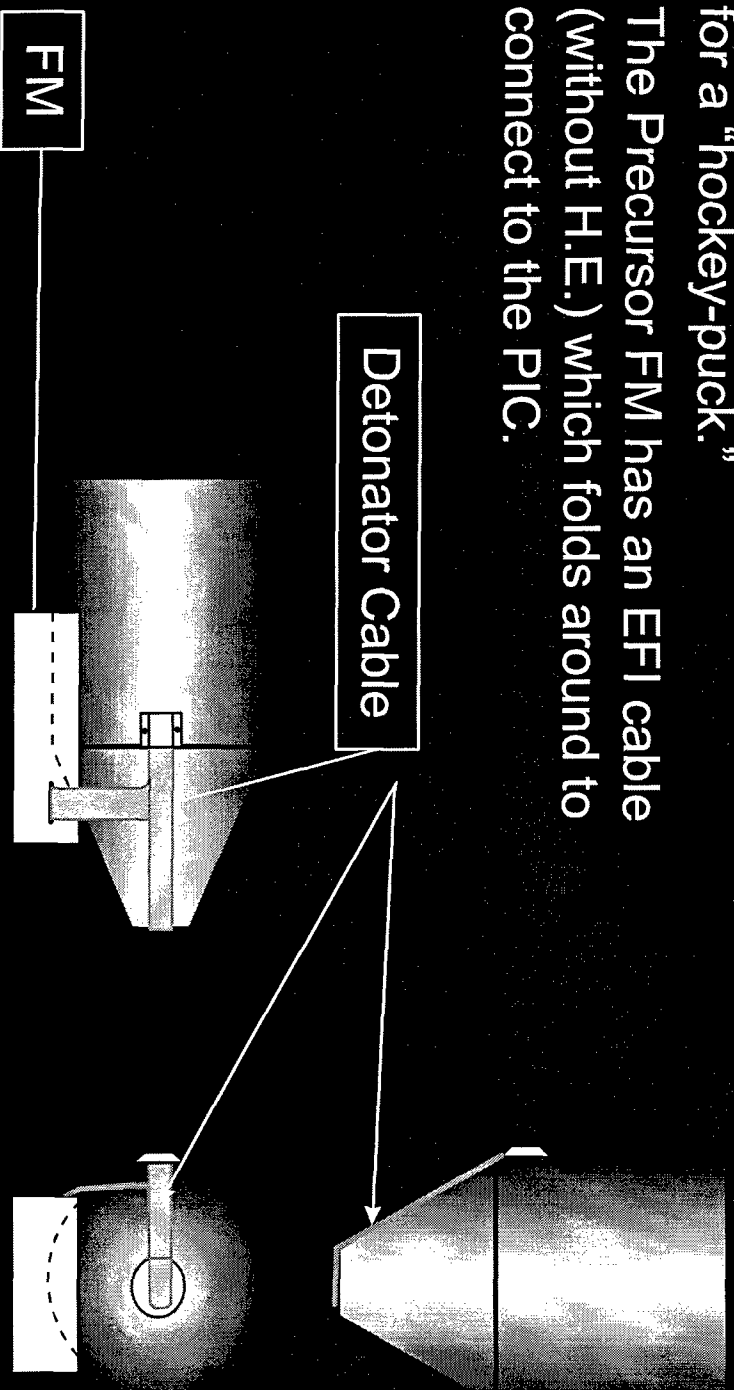

LOCKHEED MARTIN

IO 22

Extensive Design Verification Tests Caused a Redesign

- CTE Issues were addressed and corrected by repackaging the CCA.
- Trigger sensitivities were identified and completely eliminated.
- More Design Verification Tests proved all corrective actions.

MURPHY

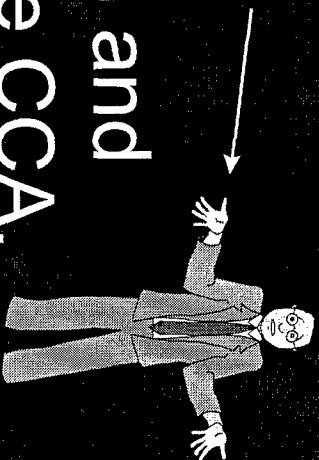

LOCKHEED MARTIN

IO 23

Qualification Was Accomplished in Two Stages

- Detonator qualified separate from FM.
- EM and FM (with detonator) qualified together as a component.

LOCKHEED MARTIN

ÌÒ 24

Blue Chip™ Detonator Qualified to Modified MIL-STD-331 G1 Spec

| Requirement | A | B | C | D | E | F | G | H | I | J | K | L | M | Total |
|--------------------------|----|----|----|----|----|----|----|----|----|----|----|----|----|-------|
| Quantity | 30 | 30 | 30 | 20 | 20 | 50 | 50 | 50 | 40 | 40 | 40 | 20 | 20 | 440 |
| Threshold Ambient | X | | | | | | | | | | | | | 30 |
| Threshold Hot, +107°C | | X | | | | | | | | | | | | 30 |
| Threshold Cold, -62°C | | | X | | | | | | | | | | | 30 |
| Max No Damage Current | | | | X | | | | | | | | | | 20 |
| No Damage Stimuli | | | | | X | | | | | | | | | 20 |
| Visual Inspection | | | | | X | | | | | | | | | 20 |
| Thermal Shock | | | | | | X | X | X | | | | | | 150 |
| 2 meter drop | | | | | | X | X | X | | | | | | 150 |
| Electro Static Discharge | | | | | | X | X | X | | | | | | 150 |
| Vibration | | | | | | X | X | X | | | | | | 150 |
| Shock | | | | | | X | X | X | | | | | | 150 |
| Thermal Shock/Humidity | | | | | | | | | | | | | X | 20 |
| Leakage | | | | | | X | X | X | | | | | | 150 |
| Resistance | | | | | | X | X | X | | | | | | 150 |
| No Damage Stimuli Hot | | | | | | | X | | | | | | | 50 |
| High Temperature Aging | | | | | | | | | X | X | X | | | 120 |
| All Fire Ambient | | | | | | X | | | X | | | | | 90 |
| All Fire Hot, +107°C | | | | | | | | X | | | | | | 90 |
| All Fire Cold, -62°C | | | | | | | X | | | X | | | | 110 |
| High Voltage Fire | | | | | | | | | | | | X | | 20 |

LOCKHEED MARTIN



IO 25

Qualified to Maximum Hellfire/Longbow, Javelin, BAT Transportation Spectra

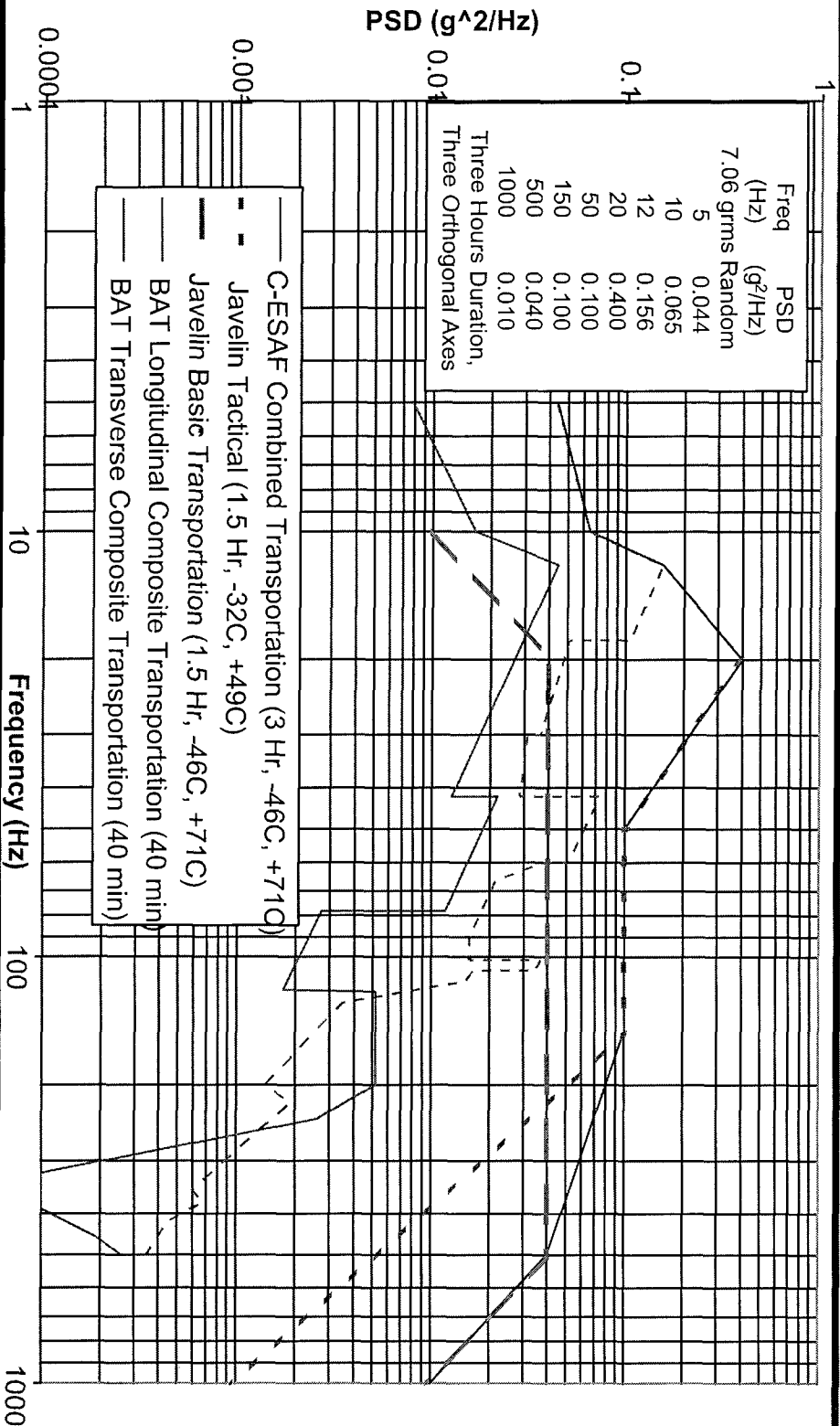

LOCKHEED MARTIN

IO 26

Qualified to Maximum Hellfire/Longbow, Javelin, BAT Flight Spectra

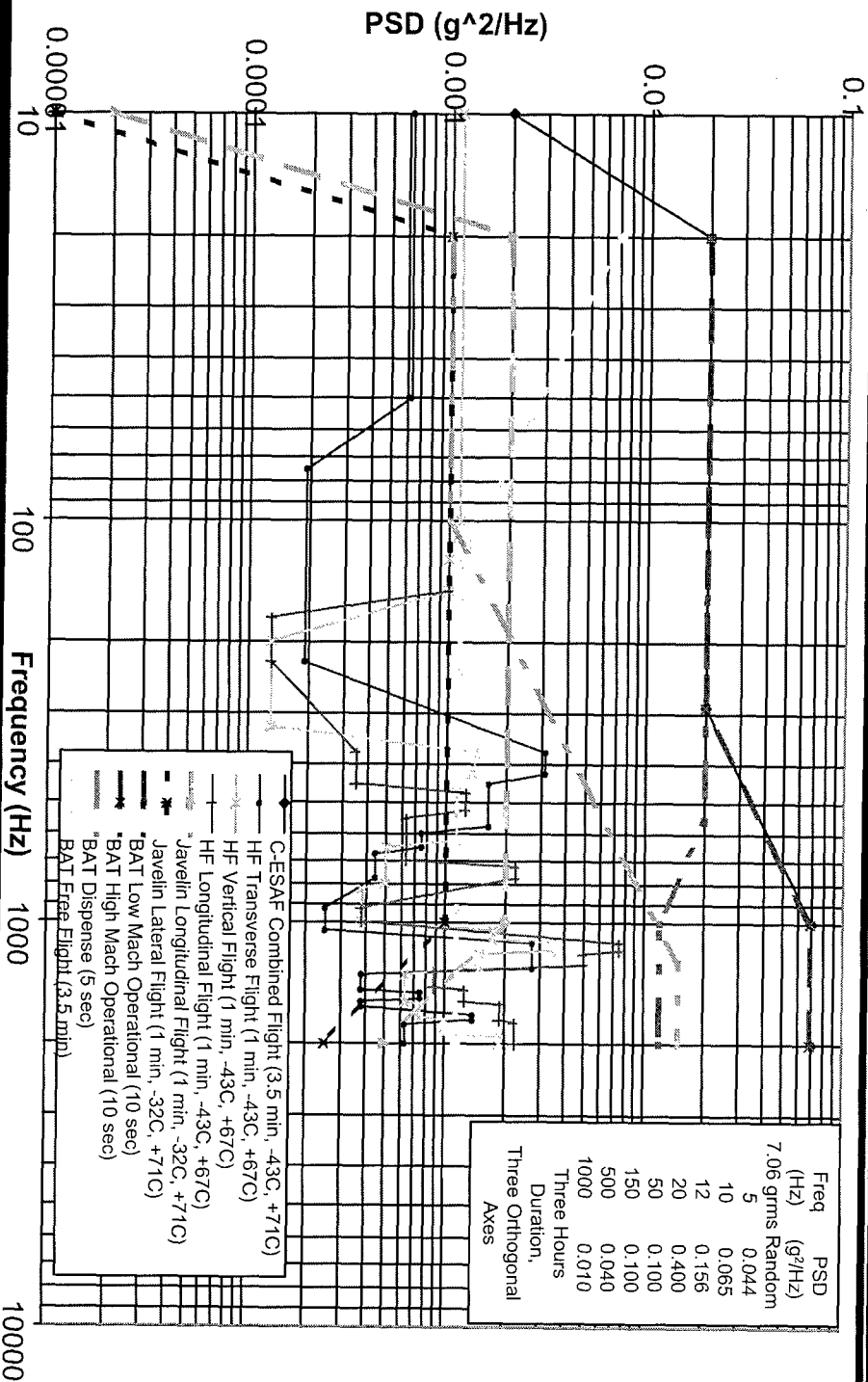

LOCKHEED MARTIN

IO 27

Blue Chip™ Detonator Passed All Qualification Tests

| Test | Requirement | Results |
|-----------------------------|--------------------------------|--|
| Environment | Survive undamaged and Function | Survived undamaged and Functioned. No change in resistance after environments. |
| Cold (No-Fire, All-Fire) | (>500, <2400) | 970, 1602 ($\mu = 1300, \sigma = 30,$) |
| Ambient (No-Fire, All-Fire) | (>500, <2400) | 1094, 1343 ($\mu = 1227, \sigma = 11$) |
| Hot (No-Fire, All-Fire) | (>500, <2400) | 993, 1379 ($\mu = 1196, \sigma = 21$) |
| Cold Dent | >9 | 16.2 average, 14.7 min |
| Ambient Dent | >15 | 19.1 average, 17.2 min |
| Hot Dent | >15 | 21.1 average, 19.4 min |
| Max No Damage Current | | > 4 Amps no damage. No reaction seen |

- No-Fire 10^{-6} probability @ 95% confidence
- All-Fire 0.99999 probability @ 95% confidence

LOCKHEED MARTIN

ÌÒ 28

Single Point Test Showed Reliable Initiation of PBX-N5

Analyzing File BLUECHIP.LEN Using Inverted Log Normal Response.
Likelihood Ratio Probability Intervals

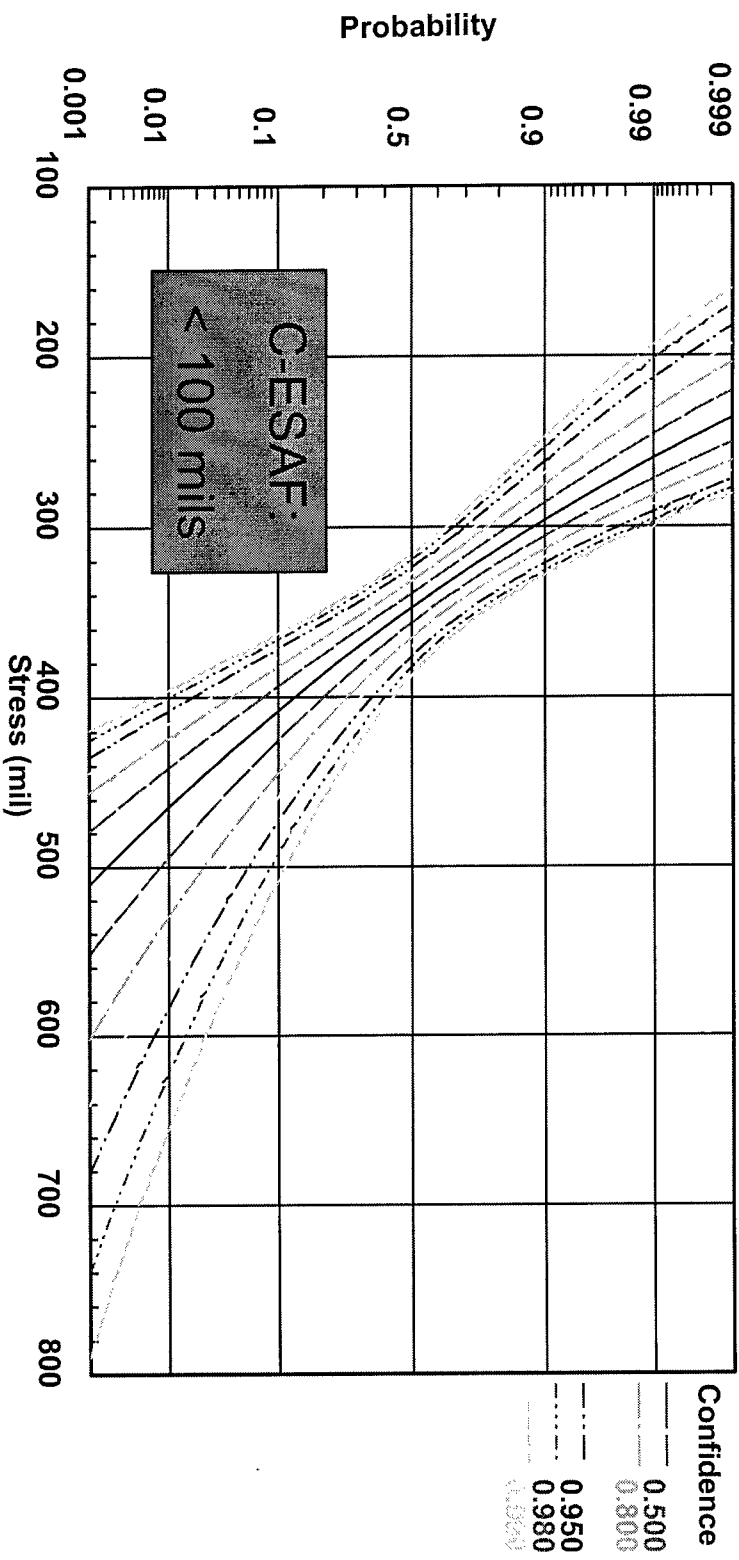

LOCKHEED MARTIN



Argon Tests Show Chip Slappers Fire "Normally"

- Overtest with electrical penalty: bare bridge in Argon
 - 2 @ 12kft, 80% Ar
 - 2 @ 23kft, 88% Ar

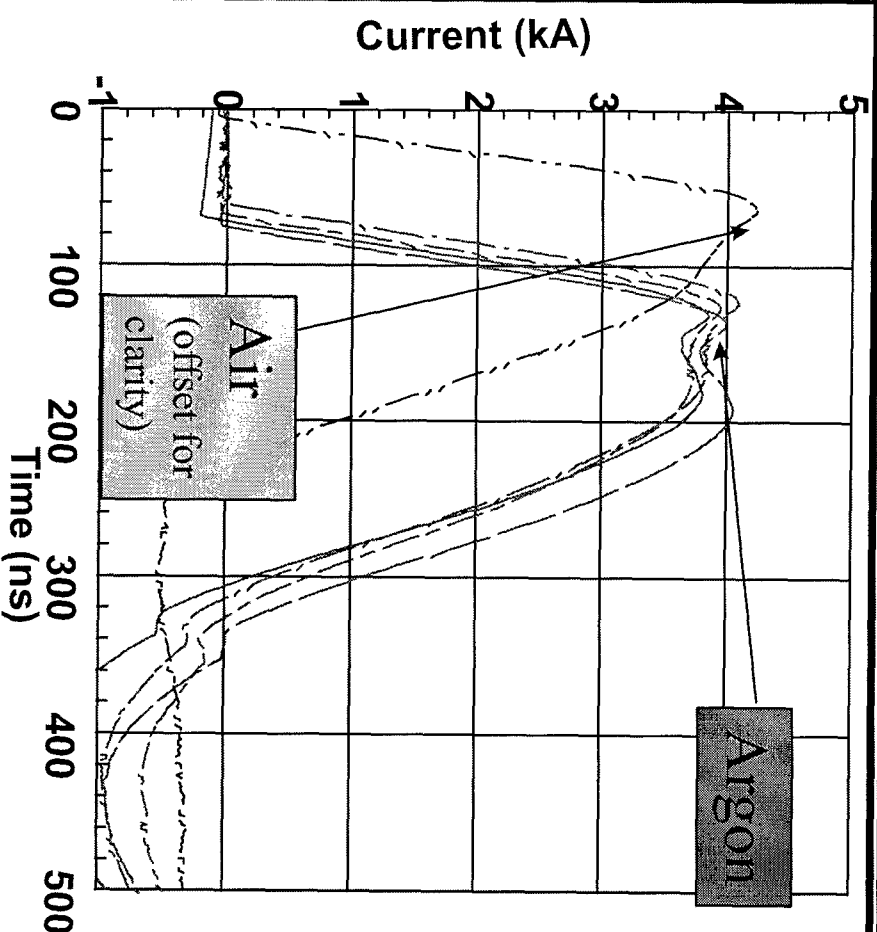

LOCKHEED MARTIN

IO 30

Production Testing of FM Will Use Inert EFI and Current Monitor

- Inert EFI assembly will allow full function in ESS
 - FM triggered at HOT and COLD
 - FM triggered during vibration
- CVR will be used to measure the output of each FM

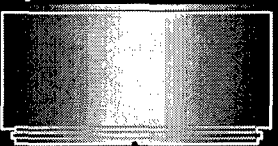

CVR
cable

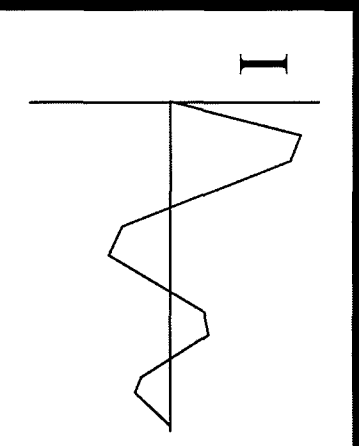

LOCKHEED MARTIN

IO 31

Component Qualification for Javelin is Nearly Complete

- All thermal and mechanical tests are complete - no failures.
- 24 Hour Argon is complete - no failures.
- Final D-test to be performed in about two weeks.

LOCKHEED MARTIN

IO 32

Production is Scheduled to Begin Ramp-Up in Early Summer

- First Javelin FRP3 deliveries of FMs are scheduled for 10/31/99.
- FRP3 is to continue through April 2000.

LOCKHEED MARTIN

IO 33