

**ADVANCED DISTRIBUTED
SIMULATION TECHNOLOGY II
(ADST II)
BICEP (DO #0049) SIMEX II/DAWE
CDRL AB02
FINAL REPORT**

23 January 1998



FOR: NAWCTSD/STRICOM
12350 Research Parkway
Orlando, FL 32826-3224
N61339-96-D-0002
DI-MISC-80711

BY: Lockheed Martin Corporation ADST II
12506 Lake Underhill Road
Orlando, FL 32825

UNCLASSIFIED

19991115 058

REPORT DOCUMENTATION PAGEForm Approved
OMB No. 074-0188

Public reporting burden for this collection of information is estimated to average 1 hour per response, including the time for reviewing instructions, searching existing data sources, gathering and maintaining the data needed, and completing and reviewing this collection of information. Send comments regarding this burden estimate or any other aspect of this collection of information, including suggestions for reducing this burden to Washington Headquarters Services, Directorate for Information Operations and Reports, 1215 Jefferson Davis Highway, Suite 1204, Arlington, VA 22202-4302, and to the Office of Management and Budget, Paperwork Reduction Project (0704-0188), Washington, DC 20503

1. AGENCY USE ONLY (Leave blank)	2. REPORT DATE 23 JAN 1998	3. REPORT TYPE AND DATES COVERED final
----------------------------------	-------------------------------	---

4. TITLE AND SUBTITLE Advanced Distributed Simulation Technology II (ADST-II) BICEP (DO #0049) SIMEX II/DAWE Final Report	5. FUNDING NUMBERS N61339-96-D-0002
---	--

6. AUTHOR(S)	
--------------	--

7. PERFORMING ORGANIZATION NAME(S) AND ADDRESS(ES) Lockheed Martin Information Systems ADST-II P.O. Box 780217 Orlando Fl 32878-0217	8. PERFORMING ORGANIZATION REPORT NUMBER ADST-II-CDRL-BICEP-9700467A
--	--

9. SPONSORING / MONITORING AGENCY NAME(S) AND ADDRESS(ES) NAWCTSD/STRICOM 12350 Research Parkway Orlando, FL 32328-3224	10. SPONSORING / MONITORING AGENCY REPORT NUMBER
--	---

11. SUPPLEMENTARY NOTES

12a. DISTRIBUTION / AVAILABILITY STATEMENT Approved for Public release; distribution is unlimited	12b. DISTRIBUTION CODE
--	------------------------

13. ABSTRACT (<i>Maximum 200 Words</i>) The SIMEX II was conducted during the period 17 - 23 September 1997 and the Division Advanced Warfighting Experiment (DAWE) was conducted from 5 - 13 November 1997 at the BICEP facility at Ft. Hood, TX. The exercises were sponsored by the Directorate of Training, Doctrine and Simulation (DOTDS), U. S. Army Aviation Center, Fort Rucker, AL. The training exercises utilized virtual simulation integrated with a notional tactical command and control network to provide training for the TF XXI AViation task force. A notional AVTOC was integrated on a tactical LAN. A DIS LAN consisted of manned simulators and computer generated forces. The two LANs were connected via the Tactical Simulation Interface Unit (TSIU). Scenarios were utilized to exercise the aircrews and command and control processes. The virtual stations included the Aviation Reconfigurable Manned Simulator (ARMS) proof of principle device and follow-on units, the Comanche Portable Cockpit (CPC), Apache-Longbow workstations, a man in-the-loop threat air defense simulator, and the Suite of Integrated Radio Frequency Countermeasures (SIRFC). This final report addresses the simulation, tactical, and communications networks developed to support the two exercises and lessons learned. This document does not address the performance of the Aviation Task Force during the exercise.
--

14. SUBJECT TERMS STRICOM, ADST-II, BICEP, simulation, DAWE XXI, C2, FT. HOOD	15. NUMBER OF PAGES 39
	16. PRICE CODE

17. SECURITY CLASSIFICATION OF REPORT UNCLASSIFIED	18. SECURITY CLASSIFICATION OF THIS PAGE UNCLASSIFIED	19. SECURITY CLASSIFICATION OF ABSTRACT UNCLASSIFIED	20. LIMITATION OF ABSTRACT
---	---	---	----------------------------

Approved for public release; distribution is unlimited

Report Documentation Page	1. Report No.	2.	3. Recipient's Accession No.
4. Title and Subtitle: ADST II BICEP DO (#0049) SIMEX II/DAWE Final Report			5. Report Date: 12/12/97
7. Author(s) John B. Abernathy & Steve W. Laibe			6.
9. Performing Organization Name and Address Lockheed Martin Corporation ADST II 12506 Lake Underhill Road Orlando, FL 32825			8. Performing Organization Rept. No. ADST II-CDRL-BICEP-9700467A
12. Sponsoring Organization Name and Address NAWCTSD/STRICOM 12350 Research Parkway Orlando, FL 32826-3224			10; Project/task/Work Unit No.
15. Supplementary Notes			11. Contract(C) or Grant(G) No. (C) N61339-96-D-0002 (G)
16. Abstract (Limit 200 words) The SIMEX II was conducted during the period 17 - 23 September 1997 and the Division Advanced Warfighting Experiment (DAWE) was conducted from 5 - 13 November 1997 at the BICEP facility at Ft. Hood, TX. The exercises were sponsored by the Directorate of Training, Doctrine and Simulation (DOTDS), U. S. Army Aviation Center, Fort Rucker, AL. The training exercises utilized virtual simulation integrated with a notional tactical command and control network to provide training for the TF XXI AVIation task force. A notional AVTOC was integrated on a tactical LAN. A DIS LAN consisted of manned simulators and computer generated forces. The two LANs were connected via the Tactical Simulation Interface Unit (TSIU). Scenarios were utilized to exercise the aircrews and command and control processes. The virtual stations included the Aviation Reconfigurable Manned Simulator (ARMS) proof of principle device and follow-on units, the Comanche Portable Cockpit (CPC), Apache-Longbow workstations, a man in-the-loop threat air defense simulator, and the Suite of Integrated Radio Frequency Countermeasures (SIRFC). This final report addresses the simulation, tactical, and communications networks developed to support the two exercises and lessons learned. This document does not address the performance of the Aviation Task Force during the exercise.			13. Type of Report & Period Covered Final Report
14.			
17. Document Analysis			
a. Descriptors BICEP; Virtual Simulation; Reconfigurable simulators; Command and Control; C2; C4I; Collective task training; DAWE XXI; SIMEX II;			
b. Identifiers/Open -Ended Terms			
c. COSATI Field/Group			
18. Availability Statement A - Approved for public release; distribution is unlimited		19. Security Class (This Report) UNC	21. No. of Pages 39
		20. Security Class (This Page) UNC	22. Price

Table of Contents

1. INTRODUCTION	1
1.1 PURPOSE.....	1
1.2 CONTRACT OVERVIEW.....	1
1.3 SIMEX II EXERCISE OVERVIEW.....	1
1.4 DAWE EXERCISE OVERVIEW.....	1
2. APPLICABLE DOCUMENTS	2
2.1 GOVERNMENT.....	2
2.2 NON-GOVERNMENT.....	2
3. SYSTEMS DESCRIPTION	2
3.1 SYSTEM CONFIGURATION AND LAYOUT.....	2
3.1.1 <i>Tactical Network Systems Description</i>	6
3.1.1.1 All Source Analysis System (ASAS).....	6
3.1.1.2 Maneuver Control System (MCS).....	6
3.1.1.3 Forward Area Air Defense Engagement Operations (FAADEO).....	6
3.1.1.4 Air and Missile Defense Warning System (AMDWS).....	6
3.1.1.5 Advanced Field Artillery Tactical Data Systems (AFATDS).....	6
3.1.1.6 Unmanned Aerial Vehicle (UAV).....	7
3.1.2 <i>Distributed Interactive Simulation (DIS) Network Systems Description</i>	7
3.1.2.1 Aviation Reconfigurable Manned Simulator (ARMS) (Device #1).....	7
3.1.2.2 Reconfigurable Tactical Trainer (RTT) (Devices #2, #3, and #4).....	7
3.1.2.3 Longbow Apache Workstation (LBA).....	7
3.1.2.4 Extended Air Defense Simulation (EADSIM).....	8
3.1.2.5 Stealth.....	8
3.1.2.6 Data Logger (SIMULYZER).....	8
3.1.2.7 After Action Review.....	9
3.1.2.8 Advanced Simulation Technologies incorporated (ASTi) Radio Simulation.....	9
3.1.3 <i>Tactical Simulation Interface Unit (TSIU)</i>	12
3.1.4 <i>Command, Control, Communications, Computers, and Information (C4I)</i>	12
3.1.5 <i>Software Baseline</i>	12
3.2 DATABASE AND SCENARIO DEVELOPMENT.....	13
4. INTEGRATION AND TEST PLAN	18
4.1 INTEGRATION AND TEST STRATEGY.....	18
4.2 INTEGRATION AND TEST SCHEDULE.....	19
4.2.1 <i>SIMEX II Schedule</i>	19
4.2.2 <i>DAWE Schedule</i>	21
5. CONDUCT OF THE EXERCISES	22
5.1 SIMEX II.....	22
5.2 DAWE.....	22
6. OBSERVATIONS AND LESSONS LEARNED	22
6.1 ADMINISTRATIVE.....	22
6.2 SITE INTEGRATION AND EXERCISE SUPPORT.....	25
7. CONCLUSION	28
8. ACRONYMS	28

LIST OF FIGURES

FIGURE 1 - FT. HOOD BICEP FACILITY LAYOUT3
FIGURE 2 - NETWORK ARCHITECTURE4
FIGURE 3 - AFTER ACTION REVIEW BLOCK DIAGRAM.....9
FIGURE 4 - COMMUNICATIONS NETWORK ARCHITECTURE12

LIST OF TABLES

TABLE 1 - NETWORK IP ADDRESSES5
TABLE 2 - COMMUNICATIONS PLAN.....10
TABLE 3 - RADIO NETS10
TABLE 4 - COMMUNICATIONS MATRIX11
TABLE 5 - SIMEX II/DAWE SOFTWARE BASELINE13
TABLE 6 - DATABASE COORDINATES14
TABLE 7 - BLUE ORDER OF BATTLE (AGGREGATES).....14
TABLE 8 - BLUE ORDER OF BATTLE (ENTITIES)15
TABLE 9 - BLUE ORDER OF BATTLE (MUNITIONS)16
TABLE 10 - RED ORDER OF BATTLE (AGGREGATES)16
TABLE 11 - RED ORDER OF BATTLE (ENTITIES).....17
TABLE 12 - RED ORDER OF BATTLE (MUNITIONS).....18

APPENDIXES

APPENDIX A - BICEP GFE EQUIPMENT FOR SIMEX/AWE.....31

EXECUTIVE SUMMARY

The SIMulation EXercise (SIMEX) II was conducted during the period from 17 September to 23 September 1997 and the Division Advanced Warfighting Experiment (DAWE) was conducted from 5 November to 13 November 1997 at the Battlespace Integrated Concept Emulation Program (BICEP) facility at Fort Hood, TX. The SIMEX II was conducted as a Unilateral Delivery Order (UDO) and the DAWE was completed as a normal Delivery Order (DO) #0049 under the Lockheed Martin Advanced Distributed Simulation Technology II (ADST II) contract administered by the U.S. Army Simulation Training and Instrumentation Command (STRICOM). The exercises were sponsored by the Directorate of Training, Doctrine and Simulation (DOTDS), U. S. Army Aviation Center (USAAVNC), Fort Rucker, AL. The training exercises utilized virtual simulation integrated with a notional tactical command and control network to provide training for the TF (Task Force) XXI AViation task force. A notional AViation task force Tactical Operations Center (AVTOC) was integrated on a tactical Local Area Network (LAN). A Distributed Interactive Simulation (DIS) LAN was established consisting of manned simulators and semi-automated forces. The two LANs were connected via the Tactical Simulation Interface Unit (TSIU). Scenarios were utilized to exercise the aircrews and command and control processes of the Aviation Task Force Staff.

This final report addresses the simulation, tactical, and communications networks developed to support the two exercises. The BICEP Mini-Feasibility Analysis Study (MFAS) (ADST-II-CDRL-BICEP-9700354) provided the architectural framework for the tactical and simulation LANs. Engineering integration was originally scheduled to be performed at the AViation Test Bed (AVTB). However, due to time constraints, only partial integration was performed at the AVTB during a one week period prior to deployment to Ft. Hood, TX. Government Furnished Equipment (GFE) and Government Furnished Information (GFI) for the tactical network was provided the week of 8 September 1997 by the Central Technology Support Facility (CTSF) at Fort Hood, Texas. The installation of the Army Airborne Command and Control System Maneuver Control System (MCS) was performed at Ft. Hood, TX. The initial TSIU was installed by Coleman Research Corporation (CRC) during the week of 8 September 1997 and was continually developed throughout the integration period. It was reinstalled for the DAWE prior to the follow-on exercise. In addition, several other pieces of equipment were added to the network. The Comanche Portable Cockpit (CPC) was one of the first elements added to the configuration. Apache-Longbow workstations were integrated into the configuration as well. A man-in-the-loop threat air defense simulator was provided by STRICOM's Threat Simulation Management Office (TSMO). Finally, the overall radio frequency environment was represented by Suite of Integrated Radio Frequency Countermeasures (SIRFC), a simulation provided by the Communications & Electronics COMmand (CECOM). This document does not address the performance of the Aviation Task Force during the training exercise.

1. INTRODUCTION

1.1 Purpose

The purpose of this final report is to document the ADST II effort which supported the BICEP DO (#0049) and specifically capture the exercise network configurations, observations, and lessons learned. This document does not address the operational effectiveness of the various systems or specific results of the exercise.

1.2 Contract Overview

BICEP was performed as DO #0049 under the Lockheed Martin Corporation (LMC) ADST II contract with STRICOM. The initial UDO contract required LMC to complete a M-FAS and to develop a proposal for the follow-on work. There were essentially two major activities. First was the creation of a conceptual model of support for an Army Aviation adjunct to the TRaining and Documentation Command (TRADOC) sponsored DAWE scheduled for November 1997. The second was acquisition of appropriate hardware to support the DAWE effort and still provide residual capability that could be used by both active and reserve components as a training system. The TRADOC rules of engagement required a presence at Ft. Hood for SIMEX II during September as a precursor to participation in the DAWE in November.

1.3 SIMEX II Exercise Overview.

The purpose of the BICEP UDO - SIMEX II was twofold, support a mission rehearsal function for the aviation element of TF XXI, and demonstrate the simulated environment's ability to stimulate the digital tactical command and control systems, specifically, manned simulators rounded out with ModSAF (Modular Semi-Automated Forces), the Extended Air Defense Simulation (EADSIM) and CAE, Inc.'s Integrated Tactical Environment Management System (ITEMS™). The CRC developed TSIU provided a bridge from the simulated world to the tactical world which stimulated elements of the Army Tactical Command and Control Systems (ATCCS) by taking information from the simulated environment's protocol data units (PDU's) and creating Variable Message Format (VMF) messages which were then passed to appropriate elements in the ATCCS suite of equipment.

1.4 DAWE Exercise Overview

The DAWE extended the concepts demonstrated in the SIMEX by adding additional functionality and refining the operating environment and procedures. The SIRFC and man-in-the-loop air defense threat simulator were examples of the functionality added for DAWE. In addition, three additional Reflectone built Reconfigurable Tactical Trainers (RTTs) were incorporated in the baseline configuration of the system. Also, three Apache-Longbow workstations were added. Finally, there was a natural improvement in capability as the team had enjoyed a thorough check-out during SIMEX II.

2. APPLICABLE DOCUMENTS

2.1 *Government*

ADST II Statement of Work for the Battlespace Integrated Concept Emulation Program Test Cell (BICEP-TC) Delivery Order, AMSTI-97-W048 Rev B.1, 6 August 1997.

2.2 *Non-Government*

Mini-Feasibility Analysis Study (MFAS) for the Battlespace Integrated Concept Emulation Program Test Cell (BICEP-TC) Delivery Order #0049 ADST-II-CDRL-BICEP-9700354, 19 August 1997.

Exercise Management/Control Plan for BICEP in Support of SIMEX II and Division XXI AWE. ADST-II-PLAN-BICEP-9700394A, 6 Oct 1997.

3. Systems Description

3.1 *System Configuration and Layout*

The AVTB supported the integration of a partial AVTOC (-), with its tactical network as well as ModSAF, the Aviation Reconfigurable Manned Simulator (ARMS) Proof of Principle (PoP) device, Advanced Simulation Technologies, inc. (ASTi) radio models for the DIS network, and an After Action Review (AAR) area. In addition, DOTDS provided an Apache Longbow workstation and Sikorsky Aircraft provided the CPC. The facilities at Ft. Hood, TX consist of modular buildings connected to form a single 60 ft x 48 ft area that contained all BICEP equipment for the SIMEX II. The CPC was in a trailer and was positioned next to this modular building. Figure 1 depicts the physical layout of the facility. Figure 2 depicts the SIMEX II network architecture and Table 1 lists the network Internet Protocol (IP) addresses used during the SIMEX II and DAWE. Appendix A identifies the GFE used for the SIMEX II and DAWE efforts at Ft. Hood, TX.

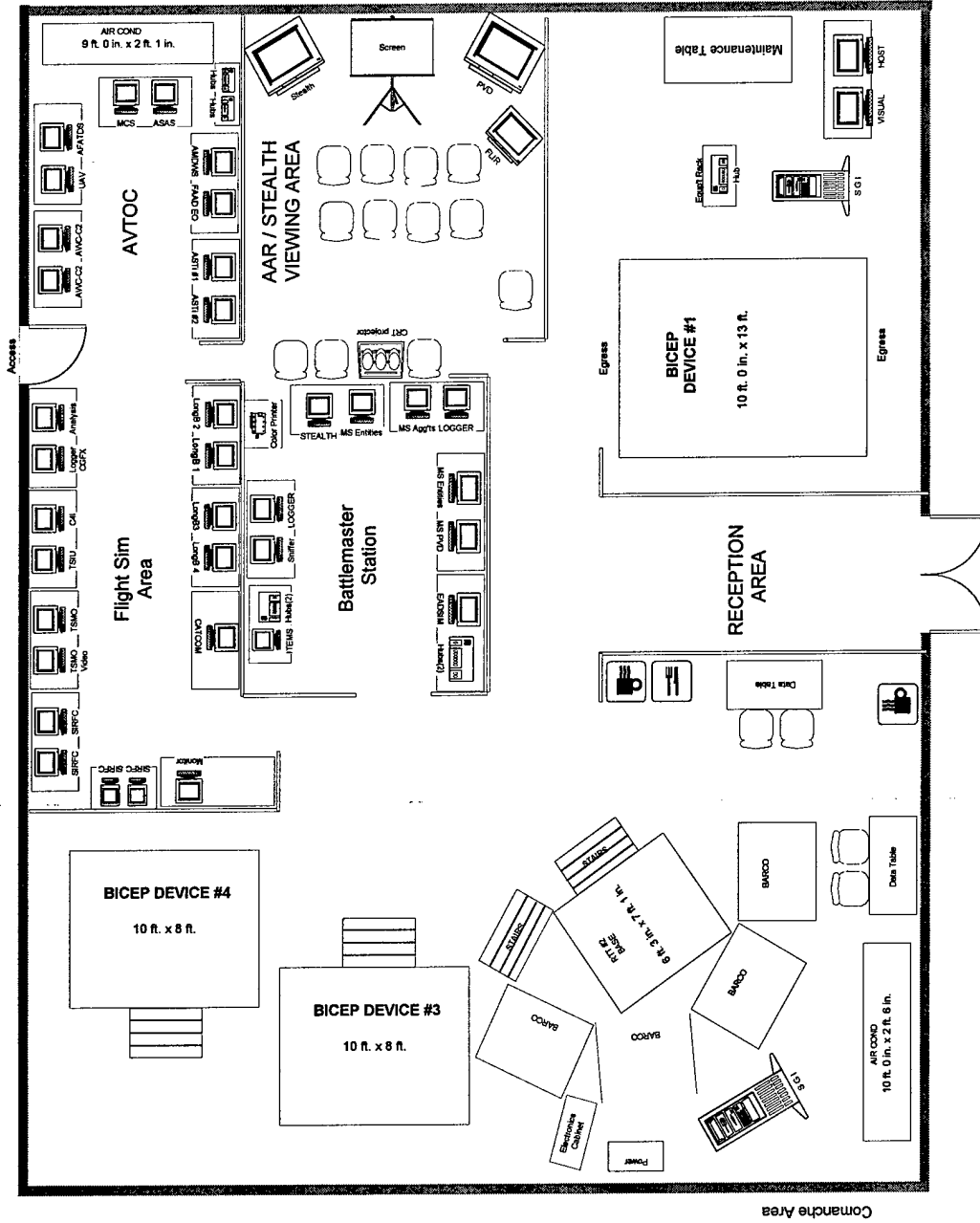

Figure 1 - Ft. Hood BICEP Facility Layout

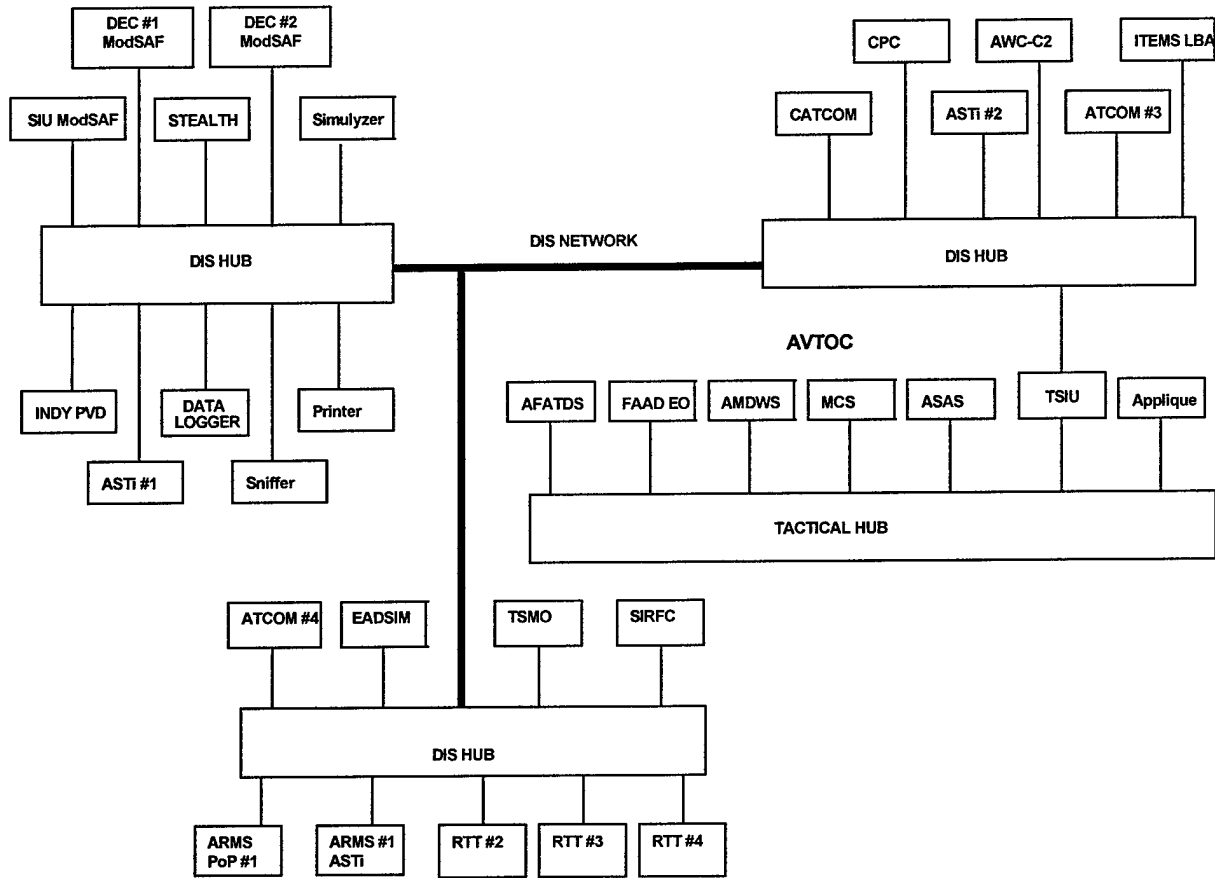

Figure 2 - Network Architecture

Table 1 - Network IP Addresses

Item	Device	IP Address	Site	Host
1	ASTI SERVER # 1	199.57.91.11	-	-
2	ASTI SERVER # 2	199.57.91.12	-	-
3	ARMS PoP #1 PDU Filter	199.57.91.255	89	1
4	CPC	199.57.91.21	91	21
5	TSIU	148.33.91.1/199.57.91.30	127	
6	C4I	199.57.91.31	127	
7	CRC Analysis Station	199.57.91.32	-	-
7	UAV	199.57.91.33	12	1
8	AWC-C2	199.57.91.41	615	1
9	MCS	148.33.36.2	-	
10	ASAS	148.33.37.1	-	
11	FAAD EO	148.33.40.100	-	
12	AMDWS	148.33.48.18	-	
13	ITEMS™	199.57.91.42	615	1
14	ATCOM	199.57.91.51	9	9
15	EADSIM	199.57.91.52	800	1
16	ModSAF 3.0	199.57.91.61	4	61
17	STEALTH	199.57.91.189	-	
19	Data Logger	199.57.91.64	-	
20	ModSAF 3.0B	199.57.91.62	4	61
21	ITEMS™ #1	199.57.91.22	91	21
22	CRC Logger	199.57.91.34	-	
23	CRC CGFX	199.57.91.35	-	
24	ARMS PoP #1 ASTi	199.57.91.10	91	10
25	RTT #2 ASTi Radio	199.57.91.14	89	2
26	RTT #2 PDU Filter	199.57.91.255	89	2
27	RTT #3 ASTi Radio	199.57.91.16	89	3
28	RTT #3 PDU Filter	199.57.91.255	89	3
29	RTT #4 ASTi Radio	199.57.91.18	89	4
30	RTT #4 PDU Filter	199.57.91.255	89	4
31	LBA ATCOM #1	199.57.91.53	9	10
32	LBA ATCOM #2	199.57.91.54	9	11
33	SIRFC	199.57.91.71	-	-
34	SIRFC ITEMS™	199.57.91.72		
34	TSMO Remote Stealth HSU	199.57.91.80	198	1
35	TSMO Remote Simulation HSU	199.57.91.81	198	
36	TSMO Local Indigo Hood	199.57.91.82	198	
37	TSMO Remote Bridge HSU	199.57.91.83	198	
38	TSMO Local Bridge Hood	199.57.91.84	198	
39	TSMO local Indigo Hood	199.57.91.85	198	
40	TSMO Local Stealth Hood	199.57.91.86	198	
41	AFATDS	148.33.38.12	-	-
42	TAFSIM	199.57.91.91	-	-

3.1.1 Tactical Network Systems Description

The tactical network supported the ATCCS systems listed below. The software for these systems were provided by the Configuration Management Office of the Force XXI CTSF. The Army Battle Command System Software was loaded directly to hard drives by the CTSF personnel. System configuration was performed at Ft. Hood by LMC engineers. The Fort Hood TF XXI architecture makes use of a router between all ATCCS systems to facilitate ease of movement of their systems. The BICEP architecture eliminated the use of routers. The MCS and All Source Analysis System (ASAS) were setup as straight workstations and the client-server functionality was turned off for the SIMEX II and DAWE. The Air and Missile Defense Warning System (AMDWS) and the Forward Area Air Defense Engagement Operations (FAADEO) were setup for client-server communications between those workstations. The ATCCS systems were integrated on one LAN using 10-base-T ethernet cable. The following is a brief description of the tactical systems.

3.1.1.1 All Source Analysis System (ASAS)

ASAS serves as the primary system for conducting Intelligence Preparation of the Battlefield (IPB) for all echelons and for updating the intelligence picture of the battlefield during the mission. For the BICEP facility, one ASAS system was integrated via the tactical LAN.

3.1.1.2 Maneuver Control System (MCS)

The MCS serves as the focal point for the ATCCS. MCS depicts the maneuver Battlefield Functional Area (BFA) and serves as the integration point for all BFA systems. For the BICEP facility, one MCS was integrated via the tactical LAN.

3.1.1.3 Forward Area Air Defense Engagement Operations (FAADEO)

The FAAD system provided an overview of the area air defense picture. The FAAD system normally takes information from Air Force, Navy, and other national assets to formulate the common air picture. This information is typically transmitted over the Enhanced Position Location Reporting System (EPLRS) throughout the FAAD network. However, for this application, it was driven by the EADSIM. The FAAD system was located in the AVTOC.

3.1.1.4 Air and Missile Defense Warning System (AMDWS)

The AMDWS is a wide area integrated view of the battlespace. It was stimulated by ASAS and MCS ATCCS inputs during SIMEX II and DAWE.

3.1.1.5 Advanced Field Artillery Tactical Data Systems (AFATDS)

AFATDS was added to allow the field artillery component of the combined arms team to be represented. It was a one way extraction of information from the simulation, it did not play the indirect fire mission elements in the SIMEX II and DAWE simulations. Those aspects were managed by the Battlemaster at the ModSAF workstation.

3.1.1.6 Unmanned Aerial Vehicle (UAV)

The UAV was included to introduce the commanders to the concepts of extended range reconnaissance and fire mission control. The workstation was manned by a CRC operator and introduced additional intelligence into the situational awareness component.

3.1.2 Distributed Interactive Simulation (DIS) Network Systems Description

The following systems operated on the DIS network during the exercise. DIS version 2.04 was used throughout the exercise. The simulated environment served as the stimulus for the command and control systems for the exercise.

3.1.2.1 Aviation Reconfigurable Manned Simulator (ARMS) (Device #1)

The ARMS device is a proof-of-principle manned simulator that can be configured as a UH-60A, OH-58D, or AH-64A. The ARMS PoP device provides a unique platform to analyze the simulation and training fidelity requirements for future production of ARMS devices. In order to serve this function, various equipment/systems have been assembled and connected in a manner to produce a form of training consistent with the customer's requirements. The test cell incorporates components that support training through effective visual and instrument presentations, control loading, motion (seat vibration), navigation, and communications. The components are designed in such a manner that they can be effectively reconfigured by replacing cyclics, collectives, and reloading the software for touch screen glass instrument panels to represent the UH-60A, OH-58D, and the AH-64A. Weapons delivery is available for the appropriate configurations and all aircraft are subject to attack. The device includes a Helmet-Mounted Display (HMD) or an Out-The-Window (OTW) configuration for the pilot position. The Copilot Gunner station has an OTW and head-down sensor display system. For SIMEX II and the DAWE, the ARMS device was configured as an AH-64A. During a two day training period within the DAWE, the device was reconfigured to be an OH-58D and then returned to the AH-64A configuration for the remainder of the exercise. The device operated on the DIS 2.04 network.

3.1.2.2 Reconfigurable Tactical Trainer (RTT) (Devices #2, #3, and #4)

The RTTs are a series that reflect the continued evolution of the ARMS device into a more supportable system. The basic operations remain the same. However, device #2 has a large screen display system for OTW graphics. It does not use a HMD system for the crew members. Devices #3 and #4 have advanced to HMDs for both crew members. Device #3 and #4 also have a new computer configuration that reduces the overall "footprint" and a more sophisticated flight model. All continue to operate on the DIS 2.04 protocol.

3.1.2.3 Longbow Apache Workstation (LBA)

The LBA was an ITEMS™-based Man-in-the-Loop simulator. The LBA operated at DIS 2.04 for this exercise. Throughout the exercise the ITEMS™ workstation also provided threat air defense forces.

3.1.2.4 Extended Air Defense Simulation (EADSIM)

EADSIM is a DIS-compliant simulation that provides computer-generated forces for the battle. EADSIM specifically provides the sensor picture to provide the overall air picture of the battle.

3.1.2.5 Stealth

The ADST II Stealth gives the Observer/Controller (O/C) personnel a "window" into the virtual battlefield, allowing them to make covert observations of the action occurring during the scenario. In addition, through the use of the data logger, the Stealth gives observers and analysts an AAR capability. The Stealth is a visual display platform that consists of a PVD (Plan View Display), various input devices, and a video display that provides the operator with a panoramic view of the battlefield.

The Stealth permits the controller to fly around the virtual battlefield and view the simulation without interfering with the action. The features of the Stealth allow the observer to survey the virtual battlefield from a variety of different perspectives, including:

- a. Tethered View - Allows the user to attach unnoticed to any vehicle on the virtual battlefield.
- b. Mimic View - Places the user in any vehicle on the virtual battlefield and provides the same view as the vehicle commander.
- c. Orbit View - Allows the operator to remain attached to any vehicle on the virtual battlefield and to rotate 360° about that vehicle, while still maintaining the vehicle as a center point of view.
- d. Free Fly Mode - Permits independent three-dimensional (3-D) movement anywhere in the virtual battlefield.

3.1.2.6 Data Logger (SIMULYZER)

The Data Logger is an ADST II asset that captures the network traffic and places the data packets on a disk or tape file. The Data Logger performs the following functions:

- a. Packet Recording - Receives packets from the DIS network, time stamps and then writes to a disk or tape.
- b. Packet Playback - Packets from a recorded exercise can be transmitted in real time or faster than real time. The Data Logger can also suspend playback (freeze time) and skip backward or forward to a designated point in time. The logger can be controlled directly from the keyboard or remotely from the PVD. Playback is visible to any device on the network (PVD, Stealth Vehicle, a vehicle simulator, etc.).
- c. Copying or Converting - Files are copied to another file, which can be on the same or a different medium; and files from the older version of the Data Logger can be converted to a format compatible with the current version of the Data Logger.

For the SIMEX II and DAWE, two data loggers were employed to capture the exercises.

3.1.2.7 After Action Review

The AAR suite provided the capability to display the exercises and provided 3-D stealth and PVD views. Tools for analysis and report generation were provided by the AAR. A block diagram of the AAR that was used for SIMEX II and the DAWE is depicted in Figure 3.

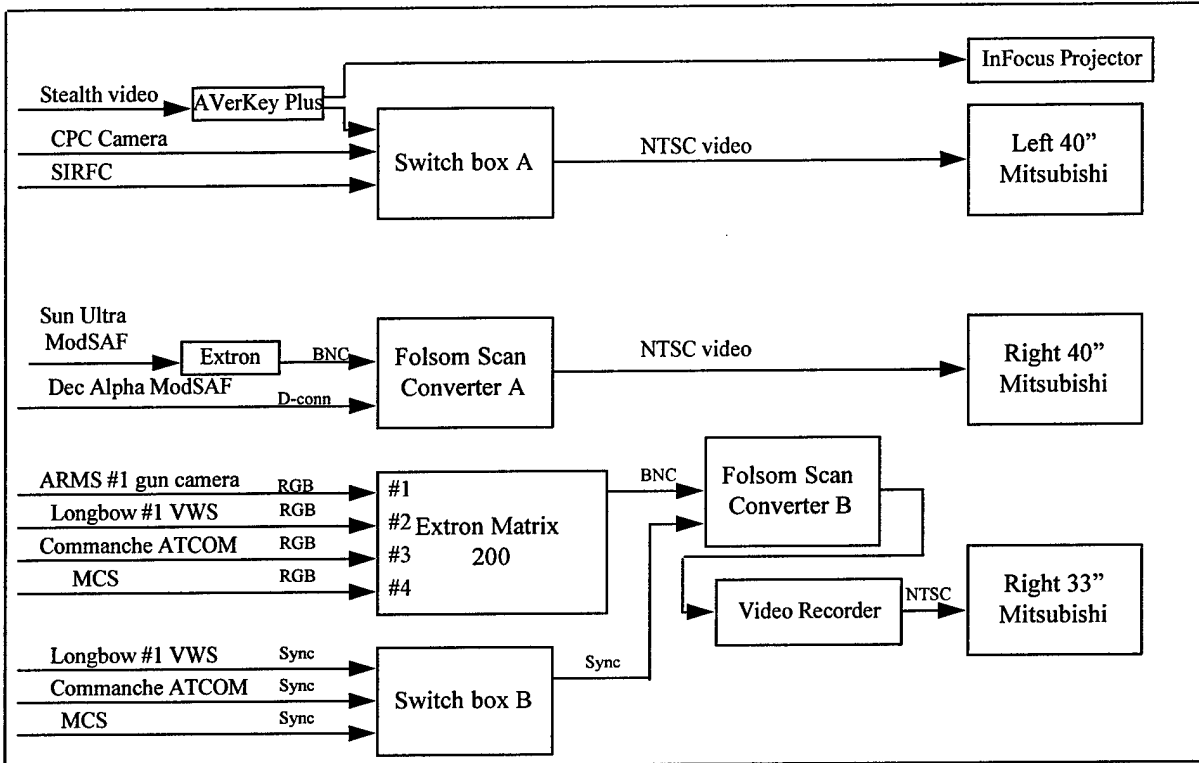

Figure 3 - After Action Review Block Diagram

3.1.2.8 Advanced Simulation Technologies incorporated (ASTi) Radio Simulation

The ASTi Digital Audio Communication System (DACS) is a commercial off-the-shelf radio product that provides digital voice communication. The ASTi DACS utilizes DIS PDUs to simulate the radio sound environment. Perfect communication was used for the ASTi radios without Line-of-Sight degradation, jamming, or propagation effects. The simulation consisted of a pentium-based simulator with Hand-Held Terminal Units and headsets. For the SIMEX II and DAWE, ASTi DACS were the means of communication for all participants. Table 2 depicts the communication plan for the exercise. Table 3 lists the radio nets available during the SIMEX II and DAWE, and Table 4 shows the interconnections available with the communications architecture shown in Figure 4 and used during the SIMEX II and DAWE.

Table 2 - Communications Plan

CALL SIGNS		SUFFIXES	
4th Avn Bde	Eagle	CDR	06
1-4 Bn	Dragon	XO	05
A Co/1-4	Viper	CSM/1SG	09
B Co/1-4	Reaper	S1	01
C Co/1-4	Sidewinder	S2	02
D Co/1-4	Dawg	S3	X-Ray
2-4 Bn	Warlock	S4	04
A Co/2-4	Nighthawk	Battle CPT	X-Ray Alpha
B Co/2-4	Banshee	Asst. Battle CPT	X-Ray Bravo
C Co/2-4	Coyote	LNO (1)	21
D Co/2-4	Maverick	LNO (2)	22
1-10 Cav Sqdn	Saber	Etc, thru LNO (9)	29
A Trp/1-10	Animal	Aircraft (1)	61
B Trp/1-10	Bulldog	Aircraft (2)	62
C Trp/1-10	Cobra	Etc, thru Aircraft (9)	69
D Trp/1-10	Outlaw		
E Trp/1-10	Renegade		
F Trp/1-10	Foxhound		
Ground Maneuver	Wolfpack		
ATC/AWACS	Arrow	EXPANDERS:	
FS	Navajo	Officer Asst	A
MEDEVAC	Dustoff	Staff Officer	B
CAS	Hog 1	NCOIC	C
FAC	Bird Dog 11	Enlisted Asst	D

Table 3 - Radio Nets

RADIO NETS		
1	CMD	31.00
2	O/I	32.00
3	Internal	33.00
4	FS	34.00
5	ATC/AWACS/MEDEVAC/ CAS/FAC	35.00

6	Ground Maneuver	36.00
---	-----------------	-------

Table 4 - Communications Matrix

POSITION	CMD NET	O/I NET	Internal NET	FS NET	ATC/ AWACS/ MEDEVAC/ CAS/FAC NET	Ground Maneuver NET
Mini-TOC						
1. CDR	X	X	X	X	X	X
2. S-2	X	X	X	X	X	X
3. S-3	X	X	X	X	X	X
4. Battle CPT	X	X	X	X	X	X
5. FSO	X	X	X	X	X	X
Battlemaster Station						
6. Battlemaster	X	X	X	X	X	X
7. FS	X	X	X	X	X	X
8. Ground Maneuver CDR	X	X	X	X	X	X
Reconfigurable Manned Sims						
9. Device #1A	X	X	X	X	X	X
10. Device #1B	X	X	X	X	X	X
11. Device #2A	X	X	X	X	X	X
12. Device #2B	X	X	X	X	X	X
13. Device #3A	X	X	X	X	X	X
14. Device #3B	X	X	X	X	X	X
15. Device #4A	X	X	X	X	X	X
16. Device #4B	X	X	X	X	X	X
Comanche Sims						
17. CPC A	X	X	X	X	X	X
18. CPC B	X	X	X	X	X	X
19. Comanche Workstation #1	X	X	X	X	X	X
Longbow Sims						
20. LBA ITEMS™ #1	X	X	X	X	X	X
21. LBA ITEMS™ #2	X	X	X	X	X	X
22. LBA ATCOM #1	X	X	X	X	X	X
23. LBA ATCOM #2	X	X	X	X	X	X

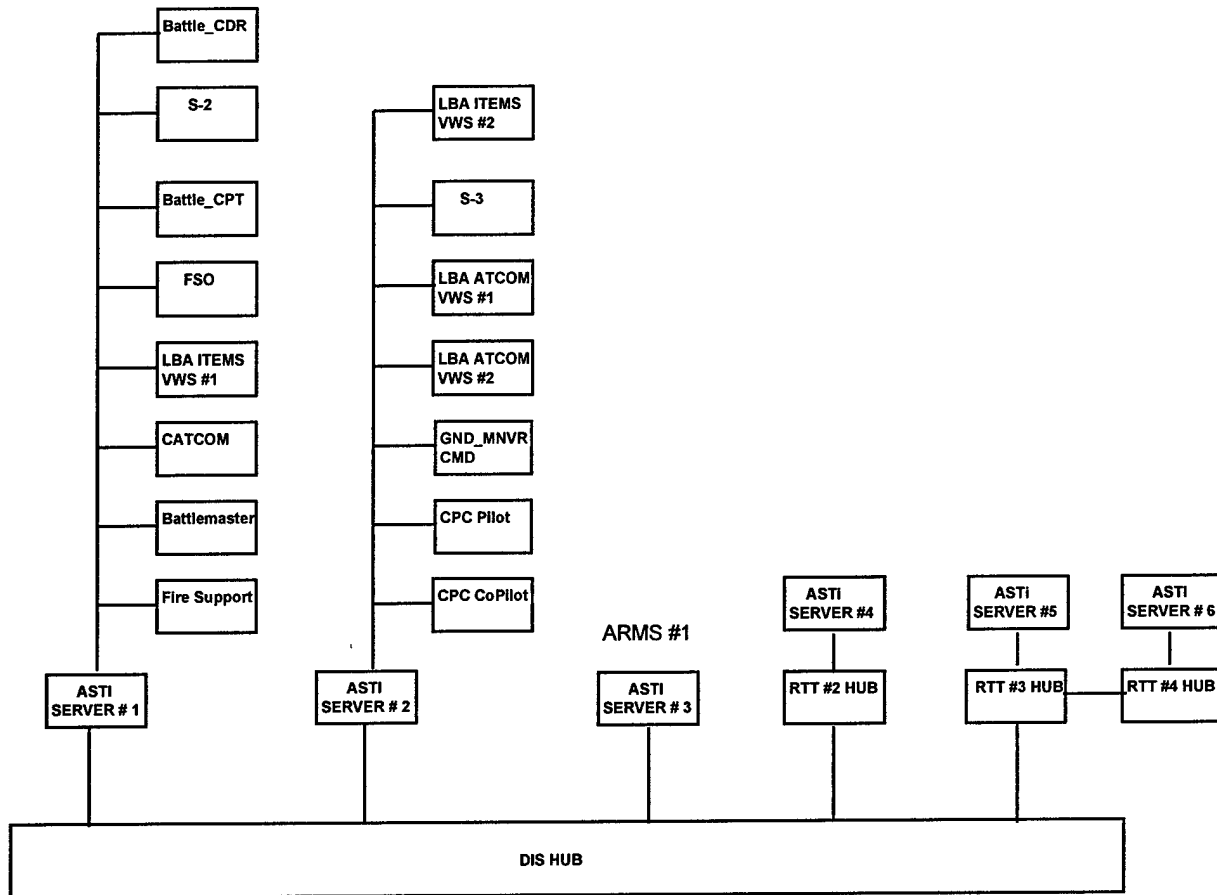

Figure 4 - Communications Network Architecture

3.1.3 Tactical Simulation Interface Unit (TSIU)

The TSIU, developed by CRC, provided the bridge between the tactical LAN and the DIS LAN. The TSIU takes UDP (User Data Protocol) formatted input from varying DIS simulations and outputs standard USMTF (United States Message Transfer Format) messages to specific ATCCS systems.

3.1.4 Command, Control, Communications, Computers, and Information (C4I)

The C4I simulation is used to add realism to the C4I elements of the battlespace. For example, it was used as a source of AWACS (Airborne Warning And Control System) and JSTARS (Joint Surveillance And Targeting Attack Radar System) information. It was also a source of digital intelligence messages.

3.1.5 Software Baseline

The SIMEX II and DAWE utilized equipment from various vendors. Table 5 documents the version of the software that was used on the various workstations/sims.

Table 5 - SIMEX II/DAWE Software Baseline

Exercise Component	Platform	Operating Sys	Application Software	Version
Stealth	PC	Windows 95	META VR	1.3
Data Logger	SGI Indigo2	IRIX 6.2	SIMULYZER	1.5
ModSAF	DEC Alpha 500	Ultrix 4.x	ModSAF	3.0
EADSIM	SGI Indigo2	IRIX 5.3		
MCS	SUN Sparc 20	Solaris 2.4	ABCSS**	2.04
ASAS	SUN Sparc 20	Solaris 2.4	ABCSS**	3.1
FAAD EO	SUN Sparc 20	Solaris 2.4	ABCCS**	3.1
AFATDS	SUN Sparc 20	Solaris 2.4	ABCCS**	3.1
AMDWS	SUN Sparc 20	Solaris 2.4	ABCCS**	3.1.1
TSIU *	SUN Sparc 20	Solaris 2.4	TSIU	5.0
C4I *	SUN Sparc 20	Solaris 2.4	C4I	3.1
UAV *	SGI Indigo II	IRIX 5.3	VR LINK	2.45
PVD *	SGI Extreme	IRIX 5.3	VR LINK	2.43
Data Logger *	SUN Sparc 10	Solaris 2.4	Data Logger	2.45
C2I	SGI Indigo II	IRIX 5.3 NFS		
ATCOM	SGI ONYX RE2		ATCOM Model	
			MaK Stealth DIS Logger Packet Server	
			Comanche MEP Emulator	
			DMA Digital Map Products for Plan Views	
ITEMS	SGI ONYX	IRIX 5.3	ITEMS	3.13
Longbow Fly Box	SGI Indigo II High Impact	IRIX 5.3 NFS	BRT-ITEMS	3.13
Longbow Fly Box	SGI Indigo II Max Impact	IRIX 5.3 NFS	BRT-ITEMS	3.13
PoP ARMS Device	PC (host) and Onyx		Reconfigurable - AH64A, OH58D and UH60	
CPC	Harris and Onyx		Comanche	
AWC-C2	SGI-Indigo	IRIX 5.3	AWC-ITEMS C2	3.13

* CRC Equipment

** ABCSS - Army Battle Command

System Software

3.2 Database and Scenario Development

A new ADST II Grafenfels terrain database was used to support the SIMEX II and DAWE. The database was derived from a common S1000 representation and converted into ModSAF CTDB

(Compressed Terrain DataBase) format as well as various Multigen variations to fit the various user configurations. The coordinates of the database are provided in Table 6. Scenario development and the order of battle (Tables 7 through 12) were provided by the DOTDS USAAVNC in conjunction with the SIMEX II and DAWE planning staff.

Table 6 - Database Coordinates

Corner	North Latitude	East Longitude
North West	50° 15' 25.2"	11° 19' 48"
North East	50° 15' 25.2"	12° 13' 33.6"
South East	49° 12' 0.0"	12° 13' 33.6"
South West	49° 01' 26.66"	11° 23' 37.41"

Table 7 - BLUE Order of Battle (Aggregates)

DIV	BDE/RGT	BN/SQDN	CO/TRP	ENTITY (VEHICLE)	NUMBER	UIC
4 ID						
	1 BDE			ModSAF	B1BDE4ID	WAEDFF
		1-66 AR		ModSAF	B166AR	WAEFFF
		3-66 AR		ModSAF	B366AR	WAEKFF
		1-22 IN		ModSAF	B122IN	WAEPPF
		1-67 AR		ModSAF	B167AR	WAFCHF
		4-42 FA		ModSAF	B442FA	WAFRFF
			A/1-44 AD	ModSAF	BA144AD	WFAGAA
	2 BDE			ModSAF	B2BDE4ID	WFAFF
		1-8 IN		ModSAF	B18IN	WAGJFF
		2-8 IN		ModSAF	B28IN	WAFHFF
		3-67 AR		ModSAF	B367AR	WAFMFF
		3-16 FA		ModSAF	B316FA	WAEUFF
		3-18 FA		ModSAF	B318FA	
			B/1-44 AD	ModSAF	BB144AD	WFAHAA
	3 BDE			ModSAF	B3BDE4ID	WAFXFF
		1-12 IN		ModSAF	B112IN	WAGEFF
		1-68 AR		ModSAF	B168AR	WAFZFF
		3-29 FA		ModSAF	B329FA	WAGOFF
			C/1-44 AD	ModSAF	BC144AD	WFAIAA
	4 BDE				B4BDE4ID	WAGUFF
		1-4 ATKHB			B14AVN	WAGVFF
			A/1-22		BA122IN	WAEQAA
			B/1-22		BB122IN	WAERAA
			C/1-22		BC122IN	WAESAA
			SCTPLT		BSCIN	
			MRTPLT		BMTRIN	
	1-214 FA			Crusader	B1214FA	
		1/C/1-44 AD	BSFV		BC144AD	

DIV	BDE/RGT	BN/SQDN	CO/TRP	ENTITY (VEHICLE)	NUMBER	UIC
	2-20 FA		MLRS		B220FA	WAKLFF
		A/1-12 IN	M2		BA112IN	
	214 FA				B214FA	
	138 FA				B138FA	
	1-44 AD				B144AD	WAKXFF
		A/3-265 AD			BA3265AD	
		A/4-200 AD			BA4200AD	

Table 8 - BLUE Order of Battle (Entities)

BN/SQDN	CO/TRP	ENTITY	SIM	Marking	UIC	ENUM
1-4 AHB	A/1-4	AH-64A	ARMS #1	BA14AVN	WAGWAA	1-2-225-20-1-2
	A/1-4	AH-64A	ARMS #3	REFLECTONE3		1-2-225-20-1-1
	A/1-4	AH-64A	ARMS #4	REFLECTONE4		1-2-225-20-1-1
	B/1-4	AH-64D	LBA ITEMS™ #1	BB14AVN	WAGXAA	1-2-225-20-1-4
	B/1-4	AH-64D	LBA ITEMS™ #2	BBW14AVN		1-2-225-20-1-4
	C/1-4	AH-64D	LBAATCOM #1	BC14AVN	WAGYAA	1-2-225-20-1-4
	C/1-4	AH-64D	LBAATCOM #2	BCW14AVN		1-2-225-20-1-4
1-10 CAV	E/1-10	RAH-66	CATCOM #1	BE110CAV	WAKVAA	1-2-225-20-4-0
	D/1-10	RAH-66	CPC	BD110CAV	WAKUAA	1-2-225-20-4-0
	A/1-10	M1A1	ModSAF	BA110CAV	WAKRAA	1-1-225-1-1-2
	B/1-10	M1A1	ModSAF	BB110CAV	WAKSAA	1-1-225-1-1-2
	C/1-10	M1A1	ModSAF	BC110CAV	WAKTAA	1-1-225-1-1-2
2-4 GSB	A/2-4	UH-60A	ARMS #2	BA24AVN	WAHBAA	1-2-225-21-2-1
	B/2-4	UH-60A		BB24AVN	WAHCAA	1-2-25-21-2-1
	C/2-4	UH-60A (A2C2S)	ITEMS™	BC24AVN	WAHDAA	1-2-225-21-2-1
1-151 AHB				B151AVN		
	A/1-151	AH-64D		BA151AVN		1-2-225-20-1-4
	B/1-151	AH-64D		BB151AVN		1-2-225-20-1-4
	C/1-151	AH-64D		BC151AVN		1-2-225-20-1-4
		A-10				1-2-225-2-4-1
		M109				1-1-225-4-3-1
		M978				1-1-225-7-19-2
		M35A2				1-1-225-7-1-6
		HMMWV				1-1-225-6-1-1
		M1A1				1-1-225-1-1-2
		M2				1-1-225-2-3-1
		M113A2				1-1-225-2-3-1
		DI	ModSAF			3-1-225-1-10-1
		AVTOC	C4I			1-1-225-5-16-9
		AWACS	EADSIM			1-2-225-8-4--2-0
		JSTARS	C4I			1-2-225-8-6-0
		UAV	C4I			1-2-225-50-5-1-0

Table 9 - BLUE Order of Battle (Munitions)

MODEL	SIM	Munition	Enumeration
AH-64A	ARMS		
		Hellfire (AGM-114)	2-2-225-1-3-3
		2.75 FFAR	2-9-225-2-21-0
		30 mm (M789HEDP)	2-9-225-2-3-0
AH-64D	ITEMS™-VWS		
		RF Hellfire	2-2-225-1-3-4
		2.75 FFAR	2-9-225-2-21-0
		30 mm (M789HEDP)	2-9-225-2-3-1
Commanche	CPC		
		Hellfire (AGM-114C)	2-2-225-1-3-3
		20 mm (GAU-8A)	2-9-225-2-1-8
A-10			
		Maverick (AGM-65)	2-2-225-1-4-0
		30 mm (GAU-8A)	2-9-225-2-3-1
OH-58D			
		Hellfire (AGM-114)	2-2-225-1-3-3
		2.75 FFAR	2-9-225-2-21-0
		.50 cal (AP)	2-2-225-2-1-1
M109			
		M107HE	2-9-225-2-14-2-2
M1 Platoon			
		M456A	2-2-225-2-10-4
		M392A	2-2-225-2-10-3
		M59 (7.62 ball)	2-8-225-2-2-7
M2			
		TOW (BGM-71)	2-2-225-1-1-1
		M919	2-2-225-2-3-3
DI			
		M855	2-8-225-2-1-5
		M59 (7.62 ball)	2-8-225-2-2-7

Table 10 - RED Order of Battle (Aggregates)

DIV	BDE/RGT	BN/SQDN	CO/TRP	ENTITY	MARKING	UIC
	17 IMRB			ModSAF	R17RGTMR	
		1MR17MRB		ModSAF	R117BNMR	
		2MR17MRB		ModSAF	R217BNMR	
		3MR17MRB		ModSAF	R317BNMR	
		4MR17MRB		ModSAF	R417BNMR	
		1TB17MRB		ModSAF	R117BNTK	
		1ATB17MRB		ModSAF	R117BNAT	
		1ART17MRB		ModSAF	R117BNART	

DIV	BDE/RGT	BN/SQDN	CO/TRP	ENTITY	MARKING	UIC
		2ART17MRB		ModSAF	R217BNART	
		1ADB17MRB		ModSAF	R117BNAD	
21 MRD				ModSAF		
	1MRR21MRD			ModSAF	R121RGTMR	
	2MRR21MRD			ModSAF	R221RGTMR	
	3MRR21MRD			ModSAF	R321RGTMR	
	1TR21MRD			ModSAF	R121RGTTK	
		1ATB21MRD		ModSAF	R121BNAT	
		1REC21MRD		ModSAF	R121BNREC	
	1ART21MRD			ModSAF	R121RGTART	
	1ADR21MRD			ModSAF	R121RGTAD	
15TD						
	150MRR15TD			ModSAF	R150RGTMR	
	152TR15TD			ModSAF	R152RGTTK	
	153TR15TD			ModSAF	R153RGTTK	
	154TR15TD			ModSAF	R154RGTTK	
		1REC15TD		ModSAF	R115BNREC	
	1ART15TD			ModSAF	R115RGTART	
	1ADR15TD			ModSAF	R115RGTAD	
	1DAG15TD					
		1ART1DAG15TD		ModSAF	R115BNART	
		2ART1DAG15TD		ModSAF	R215BNART	
		3ART1DAG15TD		ModSAF	R315BNART	
		4ART1DAG15TD		ModSAF	R415BNART	
	1RAG15TD					
		1ART1RAG15TD		ModSAF	R115BNRAG	
		2ART1RAG15TD		ModSAF	R215BNRAG	
		3ART1RAG15TD		ModSAF	R315BNRAG	
	Combat Helo					
		1 ATKH Sqdn			R1BNATK	
		2 ATKH Sqdn			R2BNATK	
		1MEDLIFTSQDN			R1BNLIFT	

Table 11 - RED Order of Battle (Entities)

BN/SQDN	CO/TRP	ENTITY	SIM	Marking	UIC	ENUM
		Hind				1-2-222-20-2-1
		2S1				1-1-222-4-2-2
		ZIL 131				1-1-222-7-4-0
		SA-9				1-1-222-4-20-0
		SA-15				1-1-222-4-48-0
		SA-8				1-1-222-4-41-0
		2S6				1-1-222-4-22-0
		ZSU-23-4				1-1-222-4-18-0
		T72				1-1-222-1-2-2
		BTR-80				1-1-222-2-13-1
		BMP2				1-1-222-2-2-1
	Platoon	T72		R1TK		1-1-222-1-2-2
	Platoon	T72		R2TK		1-1-222-1-2-2

BN/SQDN	CO/TRP	ENTITY	SIM	Marking	UIC	ENUM
	Platoon	T72		R3TK		1-1-222-1-2-2
	Platoon	BMP2	ModSAF	R1MR		1-1-222-2-2-1
	Platoon	BMP2	ModSAF	R2MR		1-1-222-2-2-1
	Platoon	BMP2	ModSAF	R3MR		1-1-222-2-2-1
	Platoon	2S6	ITEMS™	R1AD		1-1-222-4-22-0
	Platoon	2S6	ITEMS™	R2AD		1-1-222-4-22-0
	Platoon	2S6	ITEMS™	R3AD		1-1-222-4-22-0
	Platoon	2S1		R1FA		1-1-222-4-2-2
	Platoon	2S1		R2FA		1-1-222-4-2-2
	Platoon	2S1		R3FA		1-1-222-4-2-2
		TEL-1	ITEMS™	RTEL1		1-1-222-4-10-3
		TEL-2	ITEMS™	RTEL2		1-1-222-4-10-3
		TEL-3	ITEMS™	RTEL3		1-1-222-4-10-3
		TEL-4	ITEMS™	RTEL4		1-1-222-4-10-3
		TEL-5	ITEMS™	RTEL5		1-1-222-4-10-3

Table 12 - RED Order of Battle (Munitions)

MODEL	SIM	Munition	Enumeration
HIND			
		Spiral	2-2-222-1-8-0
		30 mm (ATHE)	2-2-222-2-2-0
SA-9		Gaskin	2-1-222-1-21-0
SA-8		SA-8	2-1-222-1-20-1
SA-15		SA-15 GM	2-1-222-1-27-0
BTR-80		14.5MM	2-1-222-2-2-1
BMP-2			
		Spandrel	2-2-222-1-7-0
		30 mm (HE)	2-1-222-2-6-2
		USSRD	2-8-222-2-2-2
		SA-18	2-1-222-1-30-0
T72			
		125 HEAT	2-2-222-2-18-0
		125 HE Frag	2-2-222-11-3
		125 SABOT	2-2-222-2-11-0
		12.7 MG	2-8-222-2-1-0
		USSRD	2-8-222-2-2-2
2S6			
		SA-19	2-1-222-1-31-0
		30 mm HE	2-1-222-2-6-2
ZSU-23-4			
		23 mm AP	2-1-222-2-3-2

4. Integration and Test Plan

4.1 Integration and Test Strategy

The installation, checkout and integration plan was based on a priority scheme, that is, equipment was off-loaded from the truck and installed in a pre-determined order. Test and checkout of

individual systems (e.g. AVTOC, Longbow, UAV, Aviation Training Command (ATCOM) simulators) was performed in a standalone mode (not connected to the main DIS network) until such time that the overall integration effort was ready to accept that equipment for DIS network integration. The main DIS network refers to the final facility DIS network. Local DIS networks were set-up to test multiple components of individual systems. Individual systems had to be ready for integration into the main DIS network when called for in the schedule.

Equipment was installed in the BICEP facility at Ft. Hood in the following order:

1. ARMS PoP device
2. Battlemaster Station (ModSAF, Stealth, Data Logger, Reports, printer)
3. AVTOC (MCS, ASAS, AMDWS, FAAD EO, AWC-C2, TSIU, C4I)
4. ASTI Servers and comm connections
5. Additional flight sims (CPC, ITEMSTM/Longbow, UAV, ATCOM)

As soon as equipment was installed in the facility, it was to be powered up and tested in a standalone mode to insure proper operation in preparation for DIS network integration.

Equipment was integrated into the main DIS network in the following order:

1. ARMS PoP device, CPC, ModSAF, and Stealth
2. Communications (utilizing ASTI servers) between ARMS, CPC, battlemaster station.
3. AVTOC (includes additional comm stations)
4. ITEMSTM/Longbow
5. ATCOM
6. UAV

In a parallel effort, the AAR was installed and checked out. Connections to the AAR from the ARMS device were performed when required by the AAR for testing.

4.2 Integration and Test Schedule

The schedules were as follows:

4.2.1 SIMEX II Schedule

Tuesday, September 9, 1997

AVTB Equipment arrives at Ft. Hood. CPC arrives at Ft. Hood.

Wednesday, September 10, 1997

Installation of equipment. Order of priority for equipment installation given in sec 2.5.6.1.

Begin standalone checkout of equipment as soon as it is installed and powered up.

CPC ASTI radio integration begins.

Thursday, September 11, 1997

Test and checkout of installed equipment continues.

Upgrade of ARMS device by Reflectone begins (database and navigation software).

Friday, September 12, 1997

Coleman Research begins TSIU installation and checkout. ATCSS software installation and checkout begins.

DIS network integration begins, ARMS PoP device, CPC, ModSAF, and Stealth with Communications (utilizing ASTI servers) between ARMS, CPC, battlemaster station.

Saturday, September 13, 1997

TSIU integration continues.

ATCSS integration continues.

DIS network integration of ARMS PoP device, CPC, ModSAF, Stealth and Data Logger integration continues.

Sunday, September 14, 1997

DIS network integration continues, AVTOC (includes TSIU, ATCSS, and additional comm stations).

Monday, September 15, 1997

DIS network integration continues, ITEMS™/Longbow, ATCOM, UAV.

Tuesday, September 16, 1997

DIS network integration continues, all systems, user familiarization, and SIMEX DRY RUN.

Wednesday, September 17, 1997

SIMEX begins at 1200 hours.

Tuesday, September 23, 1997

SIMEX ends at 1200 hours.

Thursday, Septmeber 25, 1997

CPC leaves Ft. Hood.

4.2.2 DAWE Schedule

Wednesday, October 8, 1997

CW4 Delacruz to move the vans along side the removable door NLT 9 October 1997.

Tuesday, October 14, 1997

ARMS PoP Device #2 installation begins.

Monday, October 20, 1997

Task Force XXI training begins. Duration 1 week.

Tuesday, October 21, 1997

CATI (Carmel Applied Technologies, Inc.) arrives for integration of Longbow VWS (Virtual WorkStation) #2. Pending with McDonnell Douglas.

Sunday, October 26, 1997

DOTDS team arrives.

Monday, October 27, 1997

CPC arrives at Ft. Hood.

Tuesday, October 28, 1997

ARMS Pop Devices #3 and #4 arrive, installation and checkout begin.

Wednesday, October 29, 1997

CRC team arrives begins integration.

Thursday, October 30, 1997

CATI team arrives and completes integration of Longbow device #2.

Saturday, November 1, 1997

DAWE practice runs and plan first MRE.

Wednesday, November 5, 1997

DAWE execution begins.

Thursday, November 13, 1997

DAWE ends.

Friday, November 14, 1997

Post DAWE activities and demonstrations for 11D and 21st CAV.

Wednesday, November 19, 1997

Site Closes.

5. Conduct of the Exercises

5.1 SIMEX II

The training exercises were conducted over a seven-day period 17-23 September 1997. The 1-4 Attack Helicopter Battalion received familiarization training with the ARMS devices and the tactical systems. Full-scale mission rehearsal exercises were conducted every other day. The crews were informed of the mission, given a tactical situation briefing and allowed to complete their own detailed approach to the specific mission. They performed the remainder of the mission in accordance with their unit operating procedures. The tactical staff monitored progress and collected data for the AAR.

5.2 DAWE

The exercises were conducted over a nine-day period 5-13 November 1997. The 1-4 Attack Helicopter Battalion again received familiarization training with the ARMS devices and the tactical systems. Full-scale mission rehearsal exercises were conducted on two days and demonstrations were available on off days. In addition, two days were devoted to 3-4 Cavalry (OH-58D) unit training. This was the first opportunity for an organization to use a collective capability as a training tool during its initial train-up.

6. Observations and Lessons Learned

The following discussion details the lessons learned from these two exercises. The lessons learned are looked at from an administrative and engineering perspective. Most comments focus on the lack of time available for integration and testing due to various problems. The original schedule provided for an integration period followed by a full-scale testing period. However, due to delays in starting and then an accelerated schedule to meet the SIMEX requirements, the integration period was condensed and there was no time to conduct adequate testing of the SIMEX II tactical and DIS networks prior to on-site efforts at Ft. Hood.

6.1 Administrative

Observation #1

The UDO information was not completely assimilated by the contractor team.

Discussion #1

The original UDO was modified to include the SIMEX II activity as an add-on event. Furthermore, the event was rescheduled much earlier than originally projected. As a result, the UDO tasking was performed within an extremely limited schedule. The planning documents drew heavily from the DTX (Division Training eXercise) and ATX (Army Training eXercise) previously conducted at Ft. Rucker which provided outstanding insights into the aviation

command and control process and provided a strong framework for the development of the BICEP architecture. However, it was insufficient as a complete source and was overestimated as to value.

Lesson Learned #1

Even when previous exercises are available as models, it is imperative that all aspects of the current plan be analyzed for impact and completeness.

Observation #2

There needs to be an explicit integration plan with realistic risk assessment and mitigation included.

Discussion #2

Although there were general plans in the published documentation, several individuals were not able to effectively apply themselves and needed a more detailed plan with specific assignments. Additionally, it was found to be beneficial to have coordination meetings at least once each day. The team seemed to respond best if there was a single individual performing as a coordinator/decision-maker during the integration phase.

Lesson Learned #2

Make a detailed plan, have frequent meetings during integration, and use a single point coordinator.

Observation #3

Extra overtime was not planned for during the integration period.

Discussion #3

The original integration planned called for 12-hour work-days during the integration period. However, with the compressed schedule for this exercise, it quickly became apparent that even longer days would be required along with working through weekends.

Lesson Learned #3

Extra overtime support at the site is usually necessary to support a mid- to high-level integration effort.

Observation #4

Scenario development was not completed until immediately prior to the exercises.

Discussion #4

The original plan for the exercise called for the scenario to be provided 45 days prior to the exercise by DOTDS. However, the completed scenarios were not provided until a day prior to the exercise. In one case, we were challenged with a three-hour test of our capability to prepare for training. The delay in scenario development created problems in terms of the specific number and types of entities to be used during the exercise. Fortunately, the daily exercises were

derivatives of the same basic forces and entities. The flexibility and professional skill of the support staff completed all exercises on time.

Lesson Learned #4

The scenario is a critical part of the exercise. If the scenario is not ready for release, at least an approved entity list must be provided as a basis for conducting integration testing.

Observation #5

Sole source procurements are more likely to require longer to negotiate.

Discussion #5

A contractor negotiating from a sole source position can be difficult. He has a very strong position and does not feel any pressure to reach a solution. In our situation, we were running against a very short timeline and needed to award the subcontract so we could get back to the Government with our solution to the problem they had given to the ADST II team. We were also operating to get the other support equipment delivered to Ft. Hood.

Lesson Learned #5

There are significant hurdles to sole source procurements. The subcontractor has a very strong position and may be very hard to close.

Observation #6

Verification, Validation, and Accreditation (VV&A) is important.

Discussion #6

Although there was no contractual requirement for VV&A, it is necessary to run a self-checking VV&A just to get organized and ready to operate. Unfortunately, the lack of a formal effort made the process vulnerable to incomplete analysis and checking. There were several instances where information was confusing or wrong simply because there was no formal process to verify the model being used prior to its introduction. Demonstrations and to some extent loosely constructed training events can succeed without formal validation of the system. However, it was apparent that there would have been fewer instances of interruption and late night analysis if there had been a separate effort to check on the information being used in the exercise.

Lesson Learned #6

All ADST II delivery orders should have a VV&A task.

Observation #7

Numerous telephones are required to facilitate installation and integration of equipment.

Discussion #7

Invariably there are requirements to coordinate with remote sources during the installation and integration period. There were only two telephone lines into the facility and they were

overloaded during the integration period. Resourceful engineers resorted to expensive wireless communication over cell phone connections in order to complete their tasks on schedule.

Lesson Learned #7

Get the telephone communications installed first.

Observation #8

There was insufficient space for crewmembers to sit down and relax during intervals between training and flying.

Discussion #8

Due to the small space available, there was no area for crewmembers to sit down and relax between missions. When the devices are containerized, this issue may be very important because the space undoubtedly will be confined.

Lesson Learned #8

When planning for exercises, it is important to include space for crewmember relaxation.

6.2 *Site Integration and Exercise support*

Observation #1

ModSAF 2.1 proved unreliable during SIMEX II operation.

Discussion #1

During a risk assessment, it was determined that several "fixes" had been incorporated in ModSAF 2.1 and it had been the accepted configuration for previous work with the ARMS PoP device. Nevertheless, it proved unreliable with respect to fixed wing aircraft operation, marking field identification, and for operation under the usage and loading imposed by the SIMEX II scenarios. After consideration of the alternatives, it was decided to update the operating system of the machine so that we could install ModSAF 3.0. This solution proved satisfactory for the remainder of the period of operation.

Lesson Learned #1

Risk assessments and mitigation plans are not infallible.

Observation #2

Map grid zone designators did not correlate between the simulated environment and the tactical systems.

Discussion #2

The TF XXI versions of the ATCCS software switched to a new grid zone coordinate system based on the WGS84 datum. The simulation system Grafenfels database utilized an earlier grid zone designation system based on ED50 datum. This created a correlation problem for position

location passing from the simulation to the tactical environment. A conversion routine was implemented to transform from one reference datum to another.

Lesson Learned #2

All elements of an exercise must use the same reference designators or at least have an agreed-to conversion routine.

Observation #3

Although the DIS standard says that DIS will use WGS84 as a common reference datum, there are instances when exercises still run with other datums.

Discussion #3

The SIMEX II/DAWE Operations Order said that they would use the ED50 datum for the exercises. As a result, it was necessary to coordinate the reference datum in each entity playing in the exercise. The ModSAF transform was made available to all participants so that they could easily and consistently go between the two datums of interest. Once the correlation was called to everyone's attention, it was a relatively easy thing to make the appropriate corrections.

Lesson Learned #3

Always coordinate the terrain database origin for each entity in the network.

Observation #4

The time to make and run wires for the equipment was much more than anticipated.

Discussion #4

Although the pre-fab building had a computer floor, the time required to measure, make and run the wires required for the network was much greater than anticipated. The original floor plan was sufficient to get the equipment where it belonged but the connections still required a significant effort. As a result, there was an appearance of a lack of progress for a few days. This also led to a perception that there was no organization or plan.

Lesson Learned #4

There is a period of apparent chaos at the beginning of an effort of this type during which there is little evidence of progress. However, the plan will unfold and the network will come together.

Observation #5

The CPC communication buffers problem was not corrected prior to integration at Ft. Hood.

Discussion #5

CPC had discovered a problem with their communication buffer implementation during the Ft. Rucker check-out. Unfortunately, they had not had time to correct the problem prior to arriving at Ft. Hood. After adjustments by ModSAF and other simulations, CPC finally found time to fix their problem and things ran more smoothly thereafter. Every attempt should be made by the offending simulation to clear its own deficiencies prior to seeking integration unless it can be

shown that there will be no interference from the specific problem. This is related to the VV&A issue previously identified.

Lesson Learned #5

All known discrepancies should be cleared prior to attempting integration.

Observation #6

All operator positions need to have a back-up.

Discussion #6

There was no back-up for the Battlemaster at Ft. Hood. Either the support staff has to be cross-trained to cover shortages or there have to be additional personnel assigned to make sure that contingencies are covered.

Lesson Learned #6

Cover personnel contingencies with cross training.

Observation #7

The DIS network continually evolved throughout the integration period.

Discussion #7

The original DIS network estimate was generally followed during integration. Nevertheless, there were some changes. The hub system employed allowed these changes to be implemented without too much difficulty. There were no real problems with network traffic loads so it was possible to rearrange the connections without too much concern. However, it is obvious that the changes should be minimized to conserve resources.

Lesson Learned #7

The DIS network requirements need to be fully understood and locked in prior to the integration period to allow for complete testing of the system.

7. Conclusion

The BICEP architecture was extremely successful in supporting the 2-4 Aviation Task Force during SIMEX II and the DAWE. Despite an extremely compressed schedule with budgetary constraints, the integration of the tactical systems with the virtual simulations was a success.

8. Acronyms

AAR	After Action Review
ADST	Advanced Distributed Simulation Technology
AFATDS	Advanced Field Artillery Tactical Data System
AMDWS	Air and Missile Defense Warning System
ARMS	Aviation Reconfigurable Manned Simulator
ASAS	All Source Analysis System
ASTi	Advanced Simulation Technologies, Inc
ATCCS	Army Tactical Command and Control Systems
ATCOM	Aviation Training Command
AVTB	AViation Test Bed
AVTOC	AViation Tactical Operations Center
ATCCS	Army Tactical Command and Control System
ATX	Army Training eXercise
AWACS	Airborne Warning And Control System
AWC-C2	Aviation Warfighting Cell - Command and Control
BFA	Battlefield Functional Area
BICEP	Battlespace Integrated Concept Emulation Program
C2	Command and Control
C4I	Command, Control, Communications, Computers, and Information
CATI	Carmel Applied Technologies, Inc.
CDRL	Contract Data Requirements List
CECOM	Communications & Electronics Command
CPC	Comanche Portable Cockpit

CRC	Coleman Research Corporation
CTDB	Compressed Terrain DataBase
CTSF	Central Technology Support Facility
DACS	Digital Audio Communication System
DAWE	Division Advanced Warfighting Experiment
DIS	Distributed Interactive Simulation
DO	Delivery Order
DOTDS	Directorate for Training Doctrine and Simulation
DTX	Division Training eXercise
EADSIM	Extended Air Defense SIMulation
EPLRS	Enhanced Position Location Reporting System
FAAD EO	Forward Area Air Defense Engagement Operations
GFE	Government Furnished Equipment
GFI	Government Furnished Information
HMD	Helmet-Mounted Display
IP	Internet Protocol
IPB	Intelligence Preparation of the Battlefield
ITEMS™	Integrated Tactical Environment Management System
JSTARS	Joint Surveillance And Targeting Attack Radar System
LAN	Local Area Network
LBA	LongBow Apache workstation
LMC	Lockheed Martin Corporation
MCS	Maneuver Control System
MFAS	Mini-Feasibility Analysis Study
ModSAF	Modular Semi-Automated Forces
NVL	Night Vision Laboratory
O/C	Observer/Controller
OTW	Out-The-Window
PC	Personal Computer

PDU	Protocol Data Unit
PoP	Proof of Principle
PVD	Plan View Display
RTT	Reconfigurable Tactical Trainers
SIGI	Silicon Graphics Industries
SIMEX	SIMulation EXercise
SIRFC	Suite of Integrated Radio Frequency Countermeasures
STRICOM	(US Army) Simulation Training and Instrumentation Command
TF	Task Force
TRADOC	TRAINing and DOcumentaion Command
TSMO	Threat Simulation Management Office
UAV	Unmanned Aerial Vehicle
UDP	User Data Protocol
UDO	Unilateral Delivery Order
USAAVNC	U. S. Army AViatioN Center
USMTF	United States Message Transfer Format
VMF	Variable Message Format
VV&A	Verification, Validation, and Accreditation
VWS	Virtual WorkStation

APPENDIX A
BICEP GFE EQUIPMENT FOR SIMEX/AWE

ITEM #	EQUIPMENT DESCRIPTION	QTY	BICEP COMPONENT	NOTES
1	SGI INDIGO2 workstation with 20 in color monitor, 128 M RAM, 2.0 Gb Disk Storage, and Irix v6.2 OS	1	DATA LOGGER	
2	Personal Computer (PC) with 17 in color monitor, 32 Mb RAM, 3.25 in Floppy Disk Drive, and 2 Gb Disk Storage	1	STEALTH	
3	Ultra SPARC 170, 20 in Monitor, 4 Gb Disk Drive	1	REPORTS & ANALYSIS	
4	SGI ONYX RE2 with 4x150 Mhz, R4400 CPUs, 128 Mb RAM, (2) 2 Gb disks, RE2 Graphics w/2RM4, secondary Efast FXP controller, CDROM, 8mm (8500) tape drive, (1) 20 in monitor, and IRIX 5.3 NFS OS	1	ITEMS	
5	SUN Sparc20 workstation with 20 in color monitor, 128 Mb RAM, 2.1 Gb Disk Storage, and Solaris v2.4 OS	1	C4I	Provided by CRC
6	SUN Sparc20 workstation with 20 in color monitor, 256 Mb RAM, 4 Gb Disk Storage, Dual Ethernet, and Solaris v2.4 OS	1	TSIU	Provided by CRC
7	SUN Sparc20 workstation with 20 in color monitor, 224 Mb RAM, parallax graphics, (2) 4 Gb Disks Storage, and Solaris v2.5.1 OS.	1	ASAS	
8	SUN Sparc20 workstation with 20 in color monitor, 256 Mb RAM, 9.2 Gb Disk Storage(loaned), and Solaris v2.4 OS	1	MCS	
9	SUN Sparc20 workstation with 20 in color monitor, 160 Mb RAM, CG14 graphics 4 Gb Disk Storage, and Solaris v2.4.1 OS	1	FAAD EO	

ITEM #	EQUIPMENT DESCRIPTION	QTY	BICEP COMPONENT	NOTES
10	DEC Alpha workstation with 20 in color monitor, 128 b RAM, 2 Gb Disk Drive, CD ROM	1	ModSAF	
11	SUN Sparc20 workstation with 20 in color monitor, 256 Mb RAM, CG14 graphics 4.3 Gb Disk Storage, and Solaris v2.5.1 OS	1	AMDWS	ATCSCS 3.1.1
12	HP 735 workstation with HP A2094A 20 in color monitor, 256 Mb RAM, 4.3 Gb Disk Storage, and HP-UX A.09.01 OS	1	AFATDS	AFATDS version AFATDS-97.0:DIV XXI
13	SGI INDIGO II with 200 Mhz, R4400 CPU, 128 Mb RAM, (2) 2 Gb Disks, (2) 19 in monitors, IRIX 5.3 NFS OS	1	C2I	
14	SGI INDIGO II with 200 Mhz, R4400 CPU, 128 Mb RAM, 1 19 in monitor, IRIX 5.3 NFS OS	1	EADSIM	Provided by DOTDS
15	SGI ONYX RE2 w/4 CPUs, 512 Mb Ram, 4 Gb internal Disk, 4 mm tape drive, CDROM, and (1) 20 in monitor, IRIX 5.3	1	ATCOM	Provided by DOTDS
16	SGI Octanes MXI CPU, 512 Mb Ram, 2 Gb internal Disk, 4 mm tape drive, CDROM, and (1) 20 in monitor	2	LONGBOW ATCOM	Provided by SGI
17	SGI, with 200 Mhz R4400 CPU, 128 Mb RAM, High Impact Graphics, 4 Gb Disk, 19 in Monitor, IRIX 5.3 NFS OS	2	LONGBOW FLYBOX	Provided by AWAL
18	SGI INDIGO II with 200 Mhz, R4400 CPU, 256 Mb RAM, 1.2 Gb, 1 17 in monitor, VRLink 2.4.5 IRIX 5.3 NFS OS	1	UAV	Provided by CRC
19	SGI Indy with 133Mhz R4600 CPU, 64 Mb RAM, (1)1.2Gb 17 in Monitor, IRIX 6.2.	1	Simulyzer	
20	SGI Indy with 133Mhz R4600 CPU, 64 Mb RAM, (1)1.2Gb 17 in Monitor, IRIX 6.2.	1	ModSAF PVD	

ITEM #	EQUIPMENT DESCRIPTION	QTY	BICEP COMPONENT	NOTES
21	SGI Onyx (12) 194 Mhz IP25 1 Gb RAM, 4 Gb Disk Drive, IRIX 6.2	1	CPC	Provided by Sikorsky CPC sim 9711
22	SGI Indigo, 200 Mhz CPU 256 Mb RAM, 4 Gb Disk Storage IRIX 5.3 Solaris v2.5.1 OS	1	CPC	Provided by Sikorsky ITEMS 3.1
23	SGI Indy 150 Mhz CPU IP22 64 Mb RAM, 1.2 Gb Disk Storage, and IRIX 5.3	1	CPC	Provided by Sikorsky
24	Harris Nighthawk 5600 CRX/UX	1	CPC	Provided by Sikorsky CPC Model 9711
25	SGI Onyx with (4) 200 Mhz IP19 R4400 CPU, 128 Mb RAM, 1 20 in monitor, IRIX 6.2	1	TSMO SA-15	Provided by TSMO Virtual Reality Battle Command Post (VRBCP) with C3 link to FU/G75, FU is SA- 15, G75 is Acquisition radar.
26	DEC Pentium PC, 2 Gb internal Disk, CD ROM (1) 27 in monitor, SCO Unix	1	TSMO Video Link	Provided by TSMO Telexis Via Net Video Management System v3.1.
27	Personal Computer (PC) with 17 in color monitor, 64 Mb RAM, 3.25 in Floppy Disk Drive, and 2 Gb Disk Storage. Meta VR v2.0a	2	TSMO Stealth	Provided by TSMO
28	SGI Indigo II 195Mhz R10000 CPU, 192 Mb RAM, Max Impact Graphics, 4 Gb Disk, 15 in Monitor, IRIX 6.2	1	SIRFC ITEMS 4.0	Provided by Night Vision Laboratory (NVL)
29	Pentium 200 Mhz PC 64 Mb RAM, 2 Gb drive 1 15 in monitor, DOS	4	SIRFC STE	Provided by NVL
30	Pentium 166 Mhz PC 32 Mb RAM, 2 Gb drive 1 15 in monitor, windows 3.1	2	SIRFC GJAM	Provided by NVL

